



[RDL](#)

[Document](#)

[Download](#)

[Homepage](#) [Information](#) [Instructions](#)

FM 3-01.7

**Field Manual
No. FM 3-01.7**

**Headquarters
Department of the Army
Washington, DC 31 October 2000**

FM 3-01.7

AIR DEFENSE ARTILLERY BRIGADE OPERATIONS

Table of Contents

[PREFACE](#)

[Chapter 1](#)

[THE ADA BRIGADE](#)

[The Army Mission](#)

[The ADA Brigade Role in Army Operations](#)

[AAMDC Functional Comparison](#)

[ADA Brigade Role in Joint Operations](#)

[AMD Task Force](#)

[ADA Brigade Organization](#)

Chapter 2

FUNDAMENTALS OF ADA BRIGADE OPERATIONS

[The Battlefield Framework](#)

[The Environments of AMD Operations](#)

[Tenets of Army Operations](#)

[Elements of Combat Power](#)

[AD Employment Principles](#)

[ADA Employment Guidelines](#)

[The Role of the Air and Missile Defense Coordinator](#)

[AMD in the Operational Context](#)

[Joint Counterair Operations](#)

[Prioritizing the Air Defense Effort](#)

Chapter 3

ADA BRIGADE IN FORCE PROJECTION OPERATIONS

[Mobilization](#)

[Predeployment Activity](#)

[Deployment](#)

[Entry Operations](#)

[Operations](#)

[War Termination and Post Conflict Activity](#)

[Reconstitution and Redeployment](#)

[Demobilization](#)

[Chapter 4](#)

[BATTLE COMMAND](#)

[Role of the Commander](#)

[Command and Control Organizations](#)

[Battle Command Relationships](#)

[AMD Command and Support Relationships](#)

[Battle Command, Control, Communications, Computers, and Intelligence](#)

[Airspace Command and Control](#)

[Joint Battle Synchronization](#)

[Multinational Operations](#)

[Engagement Operations Principles](#)

[Warning Procedures and Alert Statuses](#)

[Coordination](#)

[Liaison Requirements](#)

[Chapter 5](#)

[AMDPCS OPERATION](#)

[AMDPCS System](#)

[AMDPCS Configuration](#)

[Hardware and Software Applications](#)

[Staff Functions and Responsibilities](#)

Chapter 6 **CORPS AIR AND MISSILE DEFENSE OPERATIONS**

Corps Operations

The Corps ADA Brigade Mission and Concept of Operations

Offensive Operations

Defensive Operations

Retrograde Operations

Encirclement Operations

Cross an Obstacle

Chapter 7 **EAC AIR AND MISSILE DEFENSE OPERATIONS**

EAC Operations

The EAC ADA Brigade Threat

The EAC ADA Brigade Concept of Operation

Operational and Tactical ADA Support

Rear Operations

Chapter 8 **SUSTAINMENT OPERATIONS**

Logistics Fundamentals

Providing ADA Functional Logistics

ADA Brigade Supply Operations

Chapter 9 **STABILITY AND SUPPORT OPERATIONS**

The Environment

[Characteristics of Stability Operations](#)

[Types of Stability Operations](#)

[Considerations for Stability Operations](#)

[Characteristics of Support Operations](#)

[Types of Support Operations](#)

[Forms of Support Operation](#)

[Considerations for Support Operation](#)

[Resource Allocation](#)

[Appendix A](#) **[THREAT](#)**

[General](#)

[Historical Perspective](#)

[Theater Missile Threat To Army Operations](#)

[Theater Ballistic Missile](#)

[Large-Caliber and Multiple Launch Rockets](#)

[Cruise Missiles](#)

[Air-to-Surface Missiles](#)

[Unmanned Aerial Vehicles](#)

[Global Threat Environment](#)

[Transnational Threat](#)

[Summary](#)

[Appendix B](#) **[AIR INTELLIGENCE PREPARATION OF THE BATTLEFIELD](#)**

[Process](#)

[Applying IPB](#)

[Appendix C](#) **[ADA COMMUNICATIONS](#)**

[Communications](#)

[Communications Support](#)

[Computers](#)

[Intelligence](#)

[Communications Systems](#)

[Tactical Digital Information Links](#)

[Intelligence Networks](#)

[Intelligence Systems-Trojan Spirit](#)

[Appendix D](#) **[EXECUTING ADA BRIGADE OPERATIONS](#)**

[Combat Information Basics](#)

[ADA Brigade Information Management](#)

[Refining Information](#)

[Shift Change Briefing](#)

[Information Displays](#)

[GLOSSARY](#)

[BIBLIOGRAPHY](#)

[AUTHENTICATION](#)

DISTRIBUTION RESTRICTION: Approved for public release: distribution is unlimited.

[RDL](#)[Table of](#)[Document](#)[Download](#)[Homepage](#) [Contents](#) [Information](#) [Instructions](#)

Preface

This field manual (FM) provides the doctrinal guidance on how air defense artillery (ADA) brigades fight in support of the U.S. Army's operations doctrine. This manual details tactics, techniques, and procedures used by ADA brigades to protect the force from aerial attack by being an integral component of Army operations in all theaters.

This FM is adaptable to all theaters. It is intended primarily for ADA commanders, staff officers, and ADA officers assigned to echelons above corps (EAC) and corps ADA brigades. It discusses ADA organizations employed at theater, joint, EAC, and Corps level.

This publication implements the following international standardization agreements (ISA):

STANAG	TITLE	EDITION
2014	Operations Orders, Annexes to Operations Orders, and Administrative/Logistics Orders	5
2019	Military Symbols	
2034	Land Forces Procedures for Allied Supply Transactions	4
3700	NATO Tactical Air Doctrine -ATP-33(B)	2
3736	Offensive Air Support Operation -ATP- 27	

The proponent for this manual is the HQ TRADOC. Send comments and recommendations on DA Form 2028 directly to Commandant, United States Army Air Defense Artillery School, ATTN: ATSA-DT-WF, Fort Bliss, Texas 79916-3802.

Unless this publication states otherwise, masculine nouns or pronouns do not refer exclusively to men.

[RDL](#)[Table of](#)[Document](#)[Download](#)[Homepage](#) [Contents](#) [Information](#) [Instructions](#)

Chapter 1

The ADA Brigade

This chapter discusses the ADA brigade's role in Army and joint operations as executed by the echelons above corps (EAC) and corps ADA brigades. Brigade commanders must understand ADA doctrine to synchronize ADA organizations and systems with the supported force's main effort. The chapter also discusses the organization of the ADA brigade.

THE ARMY MISSION

1-1. The mission of the United States Army is to protect and defend the Constitution of the United States of America. The Army does this by deterring war and, when deterrence fails, by achieving quick, decisive victory - on and off the battlefield - anywhere in the world and under virtually any conditions as part of a joint team. It does this by fulfilling its directed function of organizing, equipping, and training ready forces. The US national military strategy relies on an ability to rapidly deploy, employ, and sustain a joint force anywhere on the globe. This means that the conditions of Army operations can range from peace operations to high intensity conflict. These operations can occur in nuclear, biological, and chemical (NBC) environments, in all types of terrain, weather, and climate.

THE ADA BRIGADE ROLE IN ARMY OPERATIONS

1-2. The air defense artillery brigade is essential to the Army's theater and corps air and missile defense mission. It provides a focal point for the ADA defense design and promotes air and missile defense unity of effort within the theater. The ADA brigade focuses on protection of joint forces and theater assets. The ADA brigade provides force protection to maneuver units and other critical assets according to mission defense priorities. Air defense weapon systems of the ADA brigade provide responsive, day and night, all weather, all-altitude protection from aerial threats.

ADA BRIGADE MISSION

1-3. The ADA brigade mission is to protect the forces and selected geopolitical assets from

aerial attack, missile attack, and surveillance. This mission may require the brigade to deploy within or to a theater of operations with tactical lift assets or strategic lift assets. Elements of the brigade may deploy early to protect a lodgment or early entry operations. The brigade may operate initially under the operational control (OPCON) of the joint forces land component commander (JFLCC) or joint forces air component commander (JFACC) as brigade forces flow into theater. During all phases of the operation, the brigade must be able to integrate into the theater air defense system and provide early warning of and defend against theater missiles (TMs), manned, and unmanned aircraft. The ADA brigade mission can range from TM defense of corps or joint force commander (JFC) activities or assets to reinforcing coverage of a divisional tactical maneuver.

1-4. The EAC brigade commands and coordinates the operations of subordinate ADA battalions/task forces and assigned or attached units in the theater in the conduct of force operations (FO) and engagement operations (EO) based on the theater commander's intent as directed by the Army Air and Missile Defense Command (AAMDC). It provides the theater commander with air defense of designated high priority assets and organizations. The EAC ADA brigade may be required to move forward from theater positions to cover corps rear areas when the corps ADA brigade moves forward to cover forward corps assets. The EAC ADA brigade normally deploys as a part of the AAMDC. FM 3-01.94 addresses the operations of the AAMDC.

1-5. The corps ADA brigade protects designated assets in the corps area of operations from enemy air attack. It provides the corps commander air defense of high priority assets and organizations and provides overwatch of all forward divisions as part of the theater defense design.

ADA BRIGADE FUNCTIONS

1-6. The ADA brigade is structured to perform several essential functions. These functions are described in the following paragraphs.

Command & Control of Subordinate Units

1-7. The ADA brigade headquarters is staffed with personnel trained in the brigade's weapon systems, areas of supply, maintenance, and personnel support, as well as signal and intelligence. The ADA brigade staff also supports the commander in his air and missile defense coordinator (AMDCOORD) function. The command and control (C²) is effected from a mobile command post (CP) equipped for sustained 24-hour operations.

Integration of ADA Operations Within the Theater Air Defense System

1-8. The ADA brigade has an automated fire direction center (FDC) that manages high to

medium (HIMAD) engagement operations by providing fire distribution and fire direction to subordinate FDCs. This ensures that even in a maneuver operation, all HIMAD fires will be integrated and positively controlled. The ADA brigade headquarters includes a higher headquarters liaison section, staffed with senior ADA officers to perform face to face integration tasks with the appropriate AD C² element. Depending on the situation, this section can effect liaison with an air component air operations center, a ground component battlefield coordination detachment (BCD), a control and reporting center (CRC) or service equivalent, or an allied headquarters. The principle function of this liaison section is to ensure that brigade engagement operations are fully integrated into the airspace control plan and the procedural guidance for brigade operations.

Synchronization of ADA Operations with the Overall Corps Operation

1-9. The corps AMDCOORD has coordinating authority to ensure the synchronization of corps, divisional, EAC, and joint EW and AD assets within the corps AO. The corps ADA brigade headquarters includes an Air Defense Element (ADE) which collocates with the corps HQ to assist the brigade commander in executing his AMDCOORD duties. The ADE is staffed to support current operations, deep operations, and future plans within the corps main CP. The brigade will also provide LNO teams to the corps rear CP and tactical (TAC) CP. Depending on the situation, these may be placed in operational control (OPCON) to the ADE. The Corps ADA brigade also maintains close liaison with divisional ADA battalions and divisional CPs.

Integration of ADA Operations into the JFC

1-10. An EAC brigade commander may also serve as a deputy area air defense commander (DAADC) or as the JFLCC's theater army air and missile defense coordinator (TAAMDCOORD). This may occur if an AAMDC is not deployed to the area of operations (AO). The ADA brigade establishes liaison with the necessary joint force C² elements, including an Air Force CRC.

Provision of Early Warning

1-11. The ADA brigade headquarters is responsible for providing early warning throughout the area of operations. It must develop the plan that allows all units to receive early warning of all air or missile threats.

AAMDC FUNCTIONAL COMPARISON

1-12. The AAMDC provides a tailored air and missile defense command and control headquarters for joint operations. It performs theater level air and missile defense planning, coordination, and synchronization of the AO. The AAMDC executes the four pillars of

Theater Missile Defense (TMD). The AAMDC commander commands the EAC ADA brigade and serves as the TAAMDCOORD and DAADC. The AAMDC provides LNO capability with key C² nodes throughout the theater. Limitations of the AAMDC are no organic signal capability and limited logistic readiness center capability.

1-13. The EAC ADA brigade is tailored to provide C² for Army component operations. It executes the tactical level engagement and force operations. The EAC brigade primarily conducts the active defense of the TMD pillars. The EAC ADA brigade commander commands assigned and attached ADA battalions. The brigade is capable of running a logistic readiness center. The EAC ADA brigade does not have the capability to provide LNO support.

ADA BRIGADE ROLE IN JOINT OPERATIONS

1-14. Air defense is an element of joint defensive counterair (DCA) operations. DCA operations set the conditions for attacking the enemy to his operational and strategic depth and in doing so, help to protect the joint force. By contrast, AMD operations protect joint force land assets from air and missile attack and, in doing so, contribute to the attainment of joint DCA objectives. The desired endstate of both AMD and DCA operations is a joint force with the freedom to maneuver and attack in depth, while denying the enemy force the same capability. As a land force with the role of fighting in the air environment, ADA operations are inherently joint operations, in execution as well as planning and at all command levels. Since the corps may be directed to form a joint task force (JTF) headquarters, the corps AMDCOORD must understand all aspects of joint command and control and operations.

AMD TASK FORCE

1-15. Central to the TM battle is the AMD Task Force (TF) concept. The Theater High Altitude Area Defense (THAAD) and Patriot weapon systems will provide a two-tiered defense for high value assets located under their protective coverage. The collection of fire units that produce the coverage and their headquarters are designated an air and missile defense TF (AMDTF). The two tiers will provide near impenetrable defense, deny the enemy a preferred attack option, and support the theater and corps battles.

1-16. THAAD provides the upper tier defense against medium and short-range theater missiles. Patriot provides the lower tier defense, primarily against short-range ballistic missiles and other tactical missiles (cruise missiles and tactical air-to-surface missiles) and aerial platforms. The Patriot battalion provides the TF command and control. [Figure 1-1](#) shows the protection coverage provided by the AMDTF.

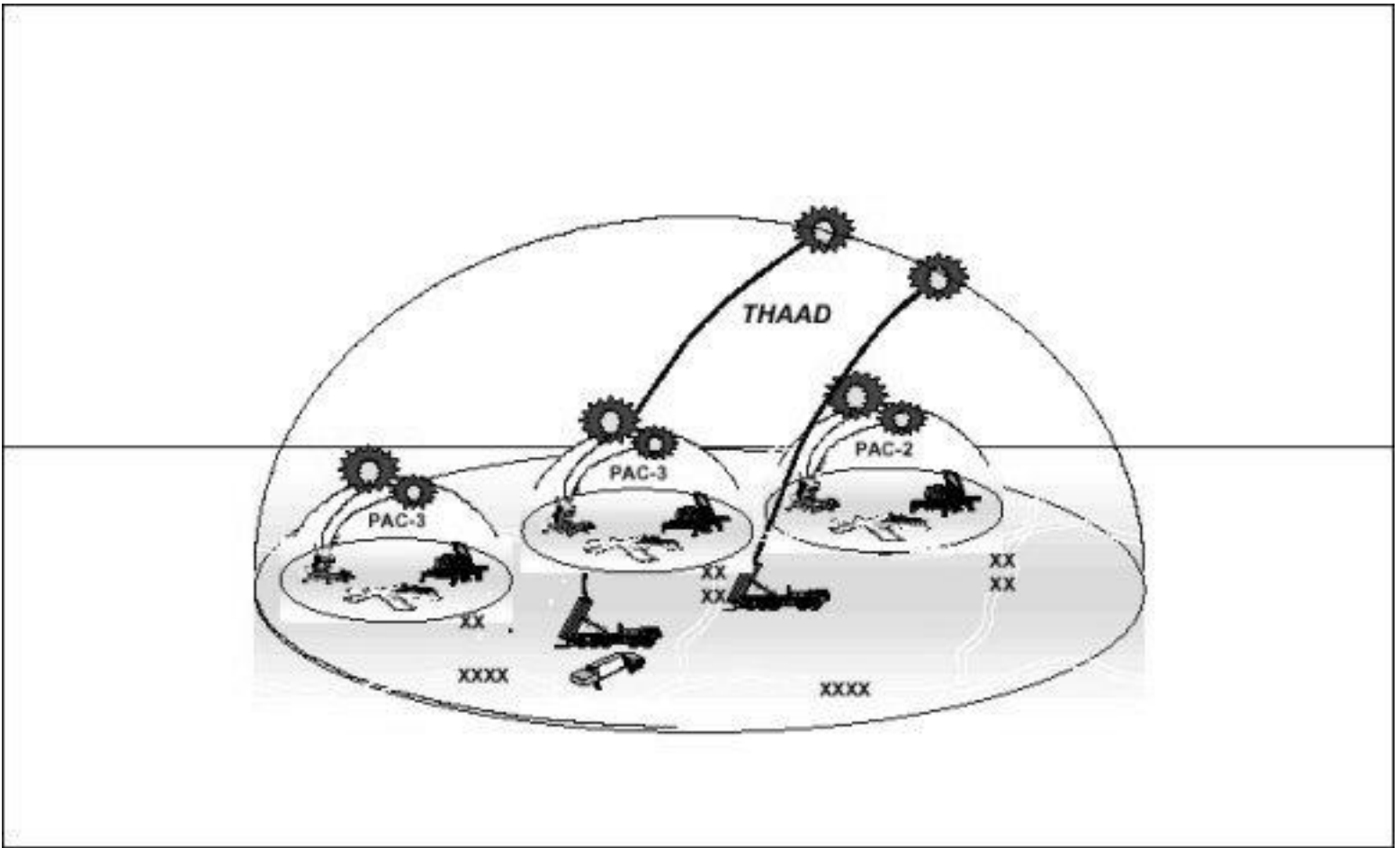

Figure 1-1. Air and Missile Defense Task Force

ADA BRIGADE ORGANIZATION

1-17. The ADA brigade is organized to meet major Army command (MACOM) or brigade commander directives to accomplish the mission. [Figure 1-2](#) illustrates a sample ADA Brigade organization. This organization shows a THAAD battery as part of the brigade for an AMDTF. The brigade will organize according to mission, enemy, terrain and weather, troops and support available, and civil considerations (METT-TC) factors, the commander's decision, and the situation.

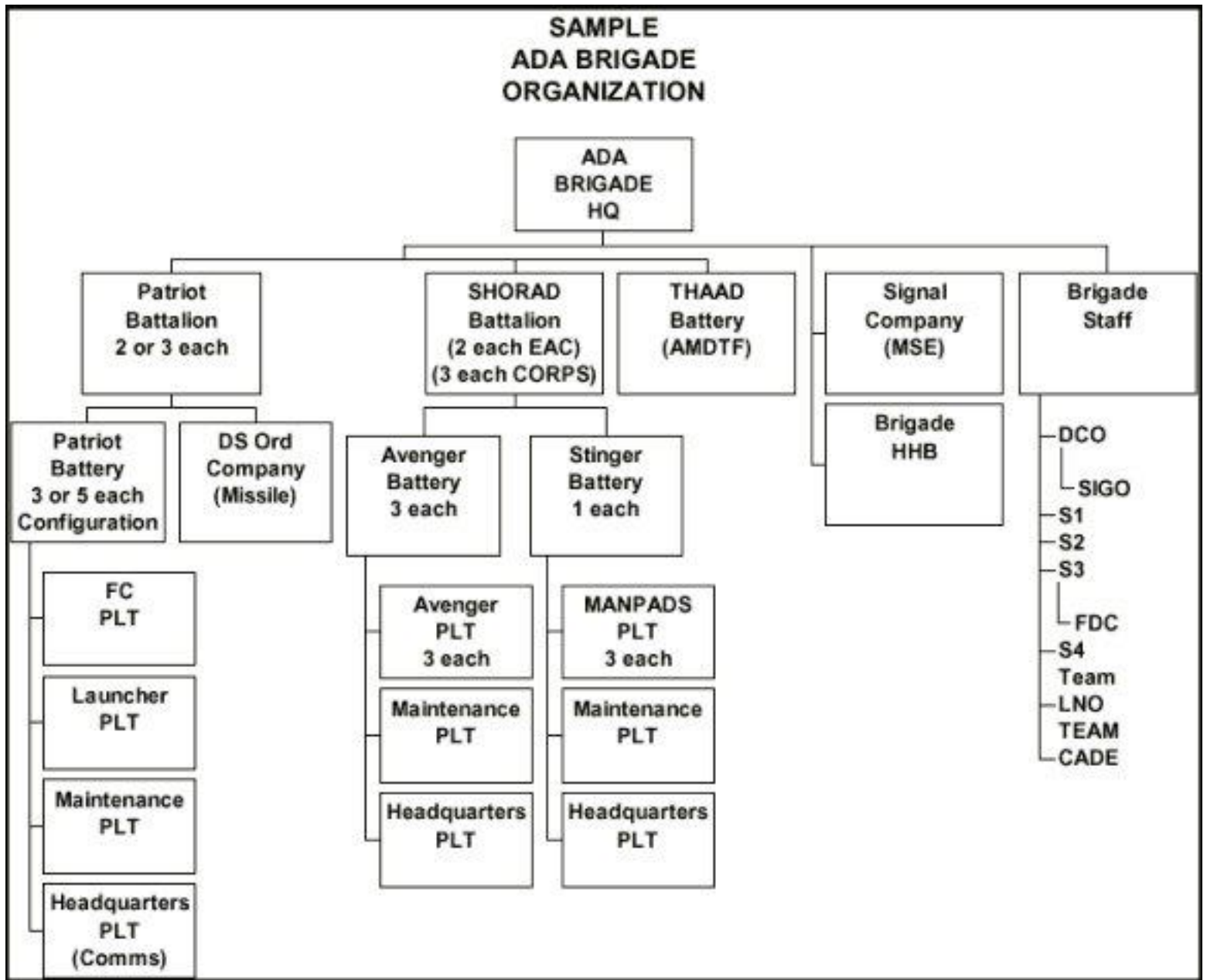

Figure 1-2. Sample ADA Brigade Organization

COMMAND SECTION

1-18. The command section is composed of the brigade commander, deputy commander, command sergeant major, coordinating staff officers, chaplain, and signal officer (SIGO). The following paragraphs highlight the major responsibilities of each section. Further information is available in [FM 6-99](#).

Commander

1-19. The commander provides leadership, direction, and guidance to his staff. The commander alone is responsible for all that his staff does or fails to do. He cannot delegate

responsibility. He is responsible for training the staff to relay information and perform the mission to conform to his leadership style.

Deputy Commander

1-20. The Deputy Commander Officer (DCO) is the commander's principal assistant for directing, coordinating, supervising, and training the staff. The DCO frees the commander from routine details and passes pertinent data, information, and insight from the staff to the commander and from the commander to the staff. He is responsible for establishing, managing, and enforcing the staff planning time line in accordance with the commander's guidance.

Command Sergeant Major

1-21. The command sergeant major (CSM) is a member of the commander's personal staff. He is the senior noncommissioned officer (NCO) of the command. The CSM is the commander's right hand for all matters concerning personal, professional, and technical advice on enlisted soldiers and the noncommissioned officer corps. His duties include monitoring and recommending actions on the morale and discipline of the command. He is required to make visits to subordinate units to monitor the morale and welfare of the enlisted soldier. He is authorized a vehicle and associated equipment.

S1, Personnel

1-22. The S1 is the principal staff officer for all matters concerning human resources. These resources include personnel readiness, personnel services, and headquarters management. Specific responsibilities of the S1 can be found in [FM 6-99](#).

S2, Intelligence

1-23. The S2 is the principal staff officer for all matters concerning military intelligence (MI), counterintelligence, security operations, and military intelligence training. Specific responsibilities of the S2 can be found in [FM 6-99](#).

S3, Operations

1-24. The S3 is the principal staff officer for all matters concerning training, operations and plans, and force development and modernization. The S3 is responsible for staff planning and supervision over electronic warfare (EW), operational security (OPSEC), and force protection. Specific responsibilities of the S3 can be found in [FM 6-99](#).

S4, Logistics

1-25. The S4 is the principal staff officer for coordinating the logistics integration of supply, maintenance, transportation, and services for the command. He is the link between the support unit and his commander. The S4 not only coordinates activities but also executes requirements for the commander and unit. Specific responsibilities of the S4 can be found in [FM 6-99](#).

Chaplain

1-26. The chaplain is the staff officer responsible for coordinating the religious assets and operations within the command. The chaplain is a confidential advisor to the commander for religious matters. Specific responsibilities of the chaplain can be found in [FM 6-99](#).

Signal Officer

1-27. The SIGO is the principal officer for all matters concerning communications operations and communications security. Specific responsibilities of the SIGO can be found in [FM 6-99](#).

ADA BRIGADE WEAPONS

1-28. The ADA brigade weapon systems include the Patriot system, the THAAD system, the Avenger system, the Stinger system, and possibly the HAWK system, depending on multinational augmentation requirements. [Figure 1-3](#) lists the capabilities of AMD weapon systems.

CAPABILITIES	LIMITATIONS	DESCRIPTION
PATRIOT		

<ul style="list-style-type: none"> ● High firepower: multiple targets tracked and engagable simultaneously ● ECM resistant ● TM capable ● All weather, day/night capable 	<ul style="list-style-type: none"> ● Heavy equipment ● Requires large amount of lift ● Large terrain/road requirement ● Cruise missiles, helicopters ● Low density weapon ● Large CSS requirement ● Launcher reload time ● Distinct electronic/visual signature 	<ul style="list-style-type: none"> ● Fire unit : Patriot battery ● Acquisition: radar + downlink ● UBL: 32 and 64 MSLs depending on configuration
--	---	--

THAAD

<ul style="list-style-type: none"> ● High firepower: multiple targets engagable simultaneously ● ECM resistant ● Endo- and exo-atmospheric intercepts ● All weather, day/night capable 	<ul style="list-style-type: none"> ● Heavy equipment ● Large terrain/road requirement ● Does not engage ABT, CMs, UAVs, TASM ● Low density weapon ● Large CSS requirement ● Distinct electronic/visual signature 	<ul style="list-style-type: none"> ● Fire unit : THAAD battery ● Acquisition: radar + downlink ● UBL: 144 MSLs
--	--	---

STINGER

<ul style="list-style-type: none"> ● Highly mobile ● Easily Transportable ● IRCM resistant ● High density weapon ● Small CSS, terrain footprint ● Head on engagement ● No visual/electronic signature ● Fire and forget 	<ul style="list-style-type: none"> ● Marginal against CMs, TASM ● Difficult shots in low clutter ● Early warning/cueing ● Limited range ● No night capability 	<ul style="list-style-type: none"> ● Fire unit : Stinger team ● Acquisition: visual ● UBL : 6 rds
---	--	--

AVENGER

<ul style="list-style-type: none"> ● Can configure as MANPADS ● FLIR aided acquisition ● Limited night ADA capability ● Limited shoot-on-the-move capability ● High density weapon ● Coaxial .50 cal. MG ● Launch station controls can be remotely operated ● 8 ready missiles 	<ul style="list-style-type: none"> ● Stinger range ● Marginal against CMs, TASM's ● Limited logistics sustainability: 2 man crew, cargo haul ● No fording, swim capability ● MG cutout zone, 270 - 18 degrees + 10 degrees elevation 	<ul style="list-style-type: none"> ● Fire unit : Avenger team ● 18 Avengers per battery ● Acquisition: visual ● UBL: 8 rds
HAWK		
<ul style="list-style-type: none"> ● Medium range ● Medium firepower ● Helicopters & ECM a/c ● Transportable by CH-47 ● All weather, day/night capable ● Reduced electronic signature w/ TAS ● TM Capable 	<ul style="list-style-type: none"> ● Saturation attacks by high performance a/c ● Marginal against CMs, TASM's ● Large CSS requirements ● Firepower: only one target at a time 	<ul style="list-style-type: none"> ● Fire unit : HAWK platoon ● Acquisition: radar + downlink ● UBL: 54 rds

Figure 1-3. Weapon System Capabilities

INTEGRATION OF BRIGADE AIR DEFENSE CAPABILITIES

1-29. The ADA Brigade must be prepared to integrate a mix of active and reserve component units as well as various technical systems in organizing for ADA operations. The ADA Brigade itself may be a reserve component element integrating active component battalions or it may be an active unit assuming command of a roundout battalion. In either case, the ADA brigade is the focal point for solving technical and procedural interoperability problems and forming a cohesive organization. The ADA brigade also is the lead for establishing AD C² and early warning architecture throughout the theater. This includes linking to national warning systems as well as AD command and control systems.

[RDL](#)[Table of](#)[Document](#)[Download](#)[Homepage](#) [Contents](#) [Information](#) [Instructions](#)

Chapter 2

Fundamentals of ADA Brigade Operations

This chapter describes the principles and fundamentals for the employment of AMD operations. It addresses the current and near term air and missile threat facing US forces in ADA brigade operations. It describes how the ADA brigade may conduct operations and helps ADA brigade commanders develop a battlefield framework to relate their forces to one another and to the enemy in time, space resources, and purpose. This chapter discusses the environment of AMD operations to include the human and physical dimension. It describes the fundamentals for employment of the air defense combat functions and the ADA brigade employment principles and guidelines. It further describes the joint counterair operations and the joint theater missile defense operations in reference to the ADA brigade.

THE BATTLEFIELD FRAMEWORK

2-1. The battlefield has a physical structure (terrain, road networks, and airspace), a command structure (boundaries and phase lines), and a potential structure that can be imposed by maneuver, fires, C2 warfare, air defense, and mobility/countermobility operations. The commander synchronizes operations by arranging activities in time and space to achieve a particular objective. Corps and EAC objectives will be different at different places. For example, the corps focuses on deep interdiction in one area, direct engagement of the enemy in another, and protection of maneuver and sustainment in still other areas. There is also a functional structure, sometimes termed battlefield geometry, which encompasses the close, deep, and rear areas. Using the factors of METT-TC, the commander seeks to arrange combat functions to shape the battlefield in order to put the enemy in a position where he can be defeated. This requires a clear understanding of the battlefield framework.

AREA OF OPERATIONS

2-2. Based on the mission and task organization, higher headquarters assigns the space within which the force operates. The force AO should be large enough to allow the commander to maneuver, conduct operations, and protect his forces. The AO of the corps

ADA brigade is normally coincident with the corps AO. The AO of the EAC ADA brigade may be the whole theater. Additionally, the Missile Engagement Zone (MEZ) provides the ADA brigade an AO in the air environment in which to fight. As authorized by the JFLCC, the AAMDC, as deputy AADC, will normally be given positioning authority of Patriot units. However, the Joint Forces Commander (JFC) may retain positioning authority for the EAC Patriot units for the TMD fight.

BATTLESPACE

2-3. The commander considers all factors of METT-TC. He attempts to develop a potential battlefield structure to dominate the enemy by fires and maneuver. The commander uses his combat power to paralyze the enemy force. The commander's spatial concept of operation is termed his battlespace. It extends beyond the three dimensions to include time. He incorporates the tempo, the duration of the operation, and the synchronization of actions. Battlespace varies in size over time and by weapons engagement or acquisition capability. It has an associated area of influence and area of interest. For example, where Army tactical missile systems (ATACMS) strikes at a particular place and time is important to the corps plan. The corps battlespace extends to encompass ATACMS targets. Battlespace is not depicted on a map or in an operations order (OPORD), but is the basis of both the commander's concept of operation and his organization of the battlefield. The battlespace of the corps ADA brigade includes the MEZ. The air defense battlespace of the corps itself, however, may extend to enemy air bases and TM launchers. These may be attacked through offensive counterair (OCA) or corps deep target nominations. The corps AMDCOORD coordinates target nominations. The battlespace for the EAC ADA brigade may include the whole theater of operations, particularly in the TMD fight. Enemy TM launchers and employment sights will be nominated for attack by the TAAMDCOORD.

BATTLEFIELD ORGANIZATION

2-4. The commander organizes his force functionally around decisive, shaping, or sustaining operations. This decision forms the basis of the concept of operations. Decisive operations at any echelon directly achieve the mission of the higher headquarters. These operations determine the outcome of major operations, battles, and engagement. Shaping operations at any echelon create and preserve conditions for success of the decisive operation. These operations include lethal and nonlethal activities conducted throughout the AO. Shaping operations support decisive operations and use the full range of military power. Sustaining operations are operations that enable shaping and decisive operations by assuring freedom of action and continuity of operations, combat service support, and command and control. Sustaining operations generate and maintain combat power. ADA brigades primarily function as a shaping force, providing the maneuver command the freedom to successfully execute decisive operations.

2-5. The commander may also organize the battlefield around close operations, deep operations, and rear operations. The focus of corps deep operations is on interdicting enemy combat power before it can be employed. Elements that can threaten the corps in the near future are attacked with corps and joint fire support attack assets. In the close fight, divisions in contact fight the current battle to defeat the enemy in the security zone and main battle area. The objective of rear operations is to protect sustainment operations and freedom of maneuver in the corps rear area. The corps commander functionally organizes the deep, rear, and close battles by means of command guidance, priorities, and coordinating measures. The corps ADA brigade contributes to deep operations through OCA target nominations and to close and rear operations through AMD defenses. The corps ADE and LNO's to the corps TAC and rear CP assist the corps AMDCOORD in all three corps operations.

THE ENVIRONMENTS OF AMD OPERATIONS

2-6. Army operations can occur within an environment of offensive, defensive, stability, and support operations. In peacetime, the Army supports national military strategy through other operations and deterrence. In periods of conflict, the Army conducts operations or limited combat operations, such as antiterrorism operations or peacekeeping operations to support strategic objectives. In war, the Army conducts combat operations against an armed enemy. In all cases, AMD operations occur within an environment that has both a physical and a human dimension. These dimensions affect how AMD operations are conducted and the survivability of AMD units and soldiers.

THE HUMAN DIMENSION

2-7. Soldiers execute operations. These soldiers are extensions both of the commander's will and of the weapon system or equipment that they operate. AMD operations frequently employ soldiers in units of squad size or smaller throughout the AO. The nature of AMD missions requires AMD soldiers to interact directly with supported company, battalion or brigade commanders. The environment of combat, combined with unique AMD requirements, places great demands on AMD soldiers. Their wrong decisions during an air and missile defense battle could result in fratricide with force-wide ramifications. To meet these challenges, AMD soldiers must be well-led by AMD commanders. They must also be physically and psychologically prepared for the rigors of battle. This task must be accomplished by small unit leaders through peacetime training and soldier development programs. In interpreting orders, AMD soldiers must be able to perform their mission and act appropriately in difficult circumstances. Orders may come from several sources and require complex rules of engagement.

THE PHYSICAL DIMENSION

2-8. AMD operations occur within three radically different physical environments, making them complex and inherently joint operations. These environments are described in the paragraphs below.

The Ground Environment

2-9. Most of the effects and events of combat operations occur within the ground environment, a two-dimensional space dominated by terrain. Terrain constrains maneuver, fires, and communications. On the other hand, terrain provides cover and concealment. Most land force units shoot, move, and communicate in this environment with predictable planning factors. Most joint force sustainment operations and lines of communication also operate in the ground environment. AMD force operations take place within the ground environment and function to protect assets and activities within this environment.

The Air Environment

2-10. In the air environment, there is no terrain. Only fuel, weather, navigation systems, and capabilities for platform and target acquisition limit aerial maneuver. Ground terrain may indirectly affect aerial maneuver, but ground maneuver forces can never compete directly with the maneuverability of air forces. On the other hand, the terrain that provides cover or conceals ground forces is not useful to air forces. Corps AMD operations maximize the vulnerability of enemy air forces through integrated defenses in depth. On the flanks of and in front of the corps, this integration includes adjacent corps AMD defenses and Air Force forces (AFFOR) DCA assets. Within the corps AO, corps divisional AMD defenses are deployed in areas of assets and activities where the enemy is most likely to attack and forward along likely enemy avenues of approach. Finally, AMD engagement operations target enemy airpower on the ground by timely OCA target nominations through the corps or Army level Deep Operations Coordination Center (DOCC).

The Environment of Space

2-11. The growing dependence of Army forces on space-based communications systems and the tactical missile threat have made the environment of space more relevant to Army operations. Space offers all of the advantages of the air environment without the fuel requirement as a significant constraint. Weather does not directly affect space-based platforms, but it does affect the ability of space sensors to acquire information. The environment of space is ideally suited for sustained command, control, communications, computers, and intelligence (C⁴I) operations. It provides global reach to the C² and intelligence combat functions. ADA brigades receive intelligence from space-based systems and conduct engagement operations against tactical missiles flying through this environment. [Figure 2-1](#) depicts the air and space environments.

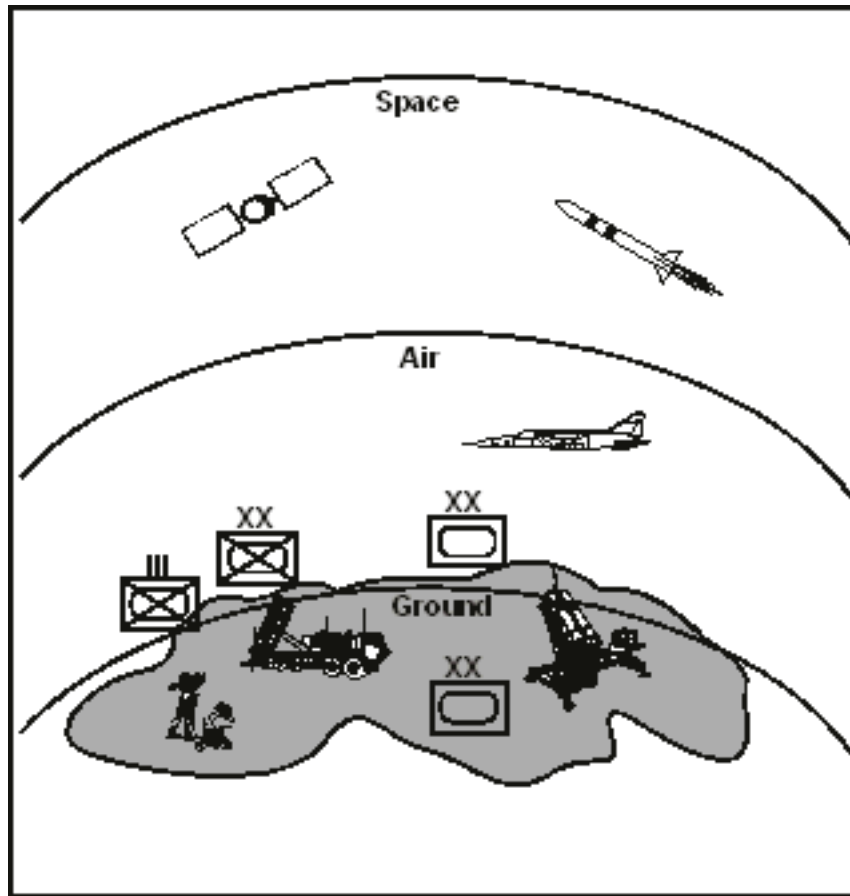

Figure 2-1. Air and Space Environments

THE AIR DEFENSE COMBAT FUNCTION

2-12. The combat operating model describes operations in the ground environment in terms of systems. Each system affords the commander certain capabilities, but brings with it certain resource costs and tactical risks. The commander's concept of operation consists mainly of how he trades off capabilities and constraints among the seven battlefield operating systems of maneuver; fires; intelligence, surveillance, and reconnaissance; mobility and survivability; air defense; command and control; and combat service support. The primary effect and purpose of the AD operating system is force protection and includes both passive measures, such as camouflage and OPSEC, and active measures. The AD operating system protects the maneuver, C², intelligence, and logistics systems from interdiction by enemy air and missile forces.

TENETS OF ARMY OPERATIONS

2-13. Army operations are governed at all levels by the principles of war and by tenets of Army operations. The principles of war guide the planning of operations by outlining fundamentals that support military success. The tenets of Army operations are qualities

that ideally describe the execution of operations and influence planning. AMD operations are conducted based on the five Army tenets described in the following paragraphs.

INITIATIVE

2-14. Initiative sets or changes the terms of battle by action. The force that seizes and retains the initiative wins battles. Initiative paralyzes the enemy's C² system by diverting its focus from executing the enemy's own plan to reacting to the friendly forces' action. Offensive action is undertaken as a means of seizing the initiative. AMD operations start by anticipating where and when enemy air forces will seek battle. Well-designed AMD defenses upset the enemy's attack, canalize it away from its objective through well-executed fires, and defeat the enemy in preplanned engagement zones.

AGILITY

2-15. Agile forces are able to react faster than the enemy. Tactical agility is first of all a mental state, achieved by good training and good tactical plans. Agility requires an ability to visualize how events will unfold, to identify areas of uncertainty, to develop branch plans, and to identify points where execution decisions must be made. AMD operations are conducted against a very mobile enemy who can rapidly generate air and missile sorties. The agility of enemy air is constrained by his objective of attacking high payoff targets. It can be anticipated by effective air IPB. The ADA brigade assists the G2 in developing the air intelligence estimate by designing defenses to meet more than one likely enemy course of action. AMD agility is achieved in planning force operations. A decision support matrix, which is key in identifying decision points adjustment of the plan, may be required. In engagement operations, agility is achieved by HIMAD fire direction, positive control, and by flexible firing doctrine. Situation awareness of the air environment within the TOC keeps the commander abreast of overall trends in the air battle. Finally, agility in AMD operations is sustained by expecting the unexpected. Not all enemy actions and tactics can be anticipated. The ADA brigade must have the ability to assess the results of operations and refine tactics on the spot. Battalion standard operating procedures (SOPs) should have procedures to debrief weapons crews after significant air battles and to assess lessons learned. The after action review (AAR) process and unit training continues in wartime by focusing on assessing and neutralizing new enemy tactics.

DEPTH

2-16. Fighting only on the forward line of own troops (FLOT), whether in the offense or the defense, means accepting the enemy's terms of battle. Initiative requires the force to seek its own terms of battle. Like all of the tenets of operations, depth is a frame of mind. Commanders must think in depth in order to fight in depth. To do this, the force extends the depth of its operations to encompass the time, terrain, and friendly as well as enemy

forces that are essential to the objective. "Battlespace" describes the depth of the forces' operations. It varies with available weapons and force objectives. The corps' ability to fight in depth is afforded by the corps' plans element and the DOCC in the corps main CP. The corps ADA brigade fights throughout the corps battlespace. Engagement operations occur near term within the corps AO. Force operations put AMD forces and defenses in place before the enemy can acquire and target the designated assets or activities. The AMD doctrinal employment guideline of early engagement lays out plans for early warning systems and defenses in depth. This forces the enemy to run a lethal gauntlet and gives the defended force time to react. Deep target nominations by the corps brigade contribute to preemptive attacks on enemy air assets and their supporting structures.

SYNCHRONIZATION

2-17. Synchronization means to arrange, develop, organize, or combine to achieve a desired or maximum effect. Synchronization describes the means that a commander applies to the complementary and reinforcing effects of all military and nonmilitary assets to overwhelm the enemy at one or more decisive points. Synchronization requires controlling the tempo of operations as well as weighting and shifting efforts in a dynamic environment. Synchronization includes forces, events, rules of engagement, maneuver options, level of control, and other military and nonmilitary systems. It requires a thorough understanding of the nature of the operation. AMD operations theater-wide must be functionally integrated. The ADA brigade applies the right mix of weapon systems, using the right degree of control and operating at the right tempo to provide AMD protection. The primary function of the corps ADA brigade is to be orchestrated with the corps plan. The ADA brigade develops a prioritized coverage plan that supports the overall corps plan. It develops an AMD scheme of maneuver that maintains mobile coverage over a moving corps. The brigade integrates the complementary effects of all joint, EAC, organic and divisional AMD weapons, and AD capabilities within the corps AO. The EAC brigade orchestrates its air defense operations to support the warfighting commanders by protecting their centers of gravity and providing them with the freedom to carry the fight to the enemy.

VERSATILITY

2-18. The organization, discipline, and sophisticated command and control of military units has application to other operations. Other military operations are an integral part of US national military strategy and can occur before, during, after, or independently of wartime operations. The range of other military operational missions to a military unit is limited only by the unit's ability to organize and direct an effort toward the other military operational objective. AMD units have accomplished numerous other operation missions in recent years, including support of counterdrug operations, show of force (SWA Patriot rotations), humanitarian assistance and disaster relief (Guantanamo Bay, Haiti, Hurricane Andrew), and peace enforcement operations (Bosnia). Versatility requires the ADA

brigade to be able to perform diverse missions, but also to conduct AMD operations. The brigade does this simultaneously in air and ground environments. It performs this mission at the tactical, operational, and strategic levels of war. Versatility challenges ADA leaders to build cohesive teams and maintain solid staff and decision-making procedures. It must also transition quickly between types of operations.

ELEMENTS OF COMBAT POWER

2-19. Combat power is produced by a combination of five elements: maneuver, firepower, protection, information operations, and leadership. Leadership is the most decisive and least resource constrained element. Combat power is massed at the right time and place by means of the four elements. Military success is achieved by combat power applied effectively and disproportional against the enemy at the critical time and place. AMD contributes to combat power by protecting the force from air and missile attack and by attacking enemy air. It defeats enemy aerial reconnaissance efforts, defends assets, and avoids fratricide. AMD protection provides the force the flexibility and freedom to maneuver.

2-20. AMD combat power is produced by the dynamic interaction of these same elements. Excellent AMD leaders provide the most essential element of AMD combat power by training their units in peacetime, by deploying them rapidly and safely to the theater of operations, by developing sound tactical plans, providing clear orders and intent, and by leading from the front in executing the unit mission. AMD maneuver positions fire units at decisive points and times in a manner that maximizes the effects of surprise and psychological shock on enemy air. AMD firepower accomplishes the AMD mission of destroying or defeating enemy air and missile attacks. Positive and procedural controls mass firepower where it is needed while maintaining the operational security of the overall AMD defense. Finally, ADA commanders conserve combat power where it is not needed through management of fire unit and individual battle readiness, by enforcing safety standards, and by maintaining strict OPSEC of AMD operations.

AD EMPLOYMENT PRINCIPLES

2-21. The focus of ADA brigade planning is to accomplish assigned brigade tasks and support the commander's intent. Brigade planners use basic AD employment principles to develop the plan. AMD doctrine recognizes four employment principles as discussed in the following paragraphs.

MASS

2-22. This principle of war has been an ADA imperative since World War I. It remains valid because the ability of enemy air forces to concentrate rapidly over a target may

overwhelm even today's highly capable AMD weapons. ADA battalion missions must be flexible enough to enable subordinate units to concentrate AMD firepower to defeat the enemy where and when he chooses to mass.

MIX

2-23. Commanders task-organize their forces for the mission. They develop the concept of operation for their offensive and defensive plans. The "mixing" of units and their weapons capabilities and limitations affords the agility to meet all aspects of the threat. In AMD operations, mix refers mainly to weapon systems and sensors. The ADA brigade can provide for mixed defenses by means of missions assigned to subordinate HIMAD and short range air defense (SHORAD) battalions and in coordination with divisional ADA.

MOBILITY

2-24. Maneuver warfare seeks to employ forces to achieve position advantage over the enemy. This is central to Army operations. Tactical mobility is an essential prerequisite to conducting maneuver. The corps ADA brigade supports corps maneuver through the mobility of its units and may conduct maneuver in its own right against enemy air forces. AMD missions must provide for mobile AMD defenses that cover maneuvering forces. Mobility is achieved not only by inherent fire unit capabilities and weapons crew proficiency, but also by their synchronization with supported force operations.

INTEGRATION

2-25. AMD operations must be integrated by means of positive and procedural controls into the theater air defense system and the theater airspace control plan. Lateral integration of AMD defenses with adjacent joint and combined force AMD defenses is also a requirement. The Air Defense Artillery Employment Principles illustration in [Figure 2-2](#) shows how the principles work together to support the AMD plan.

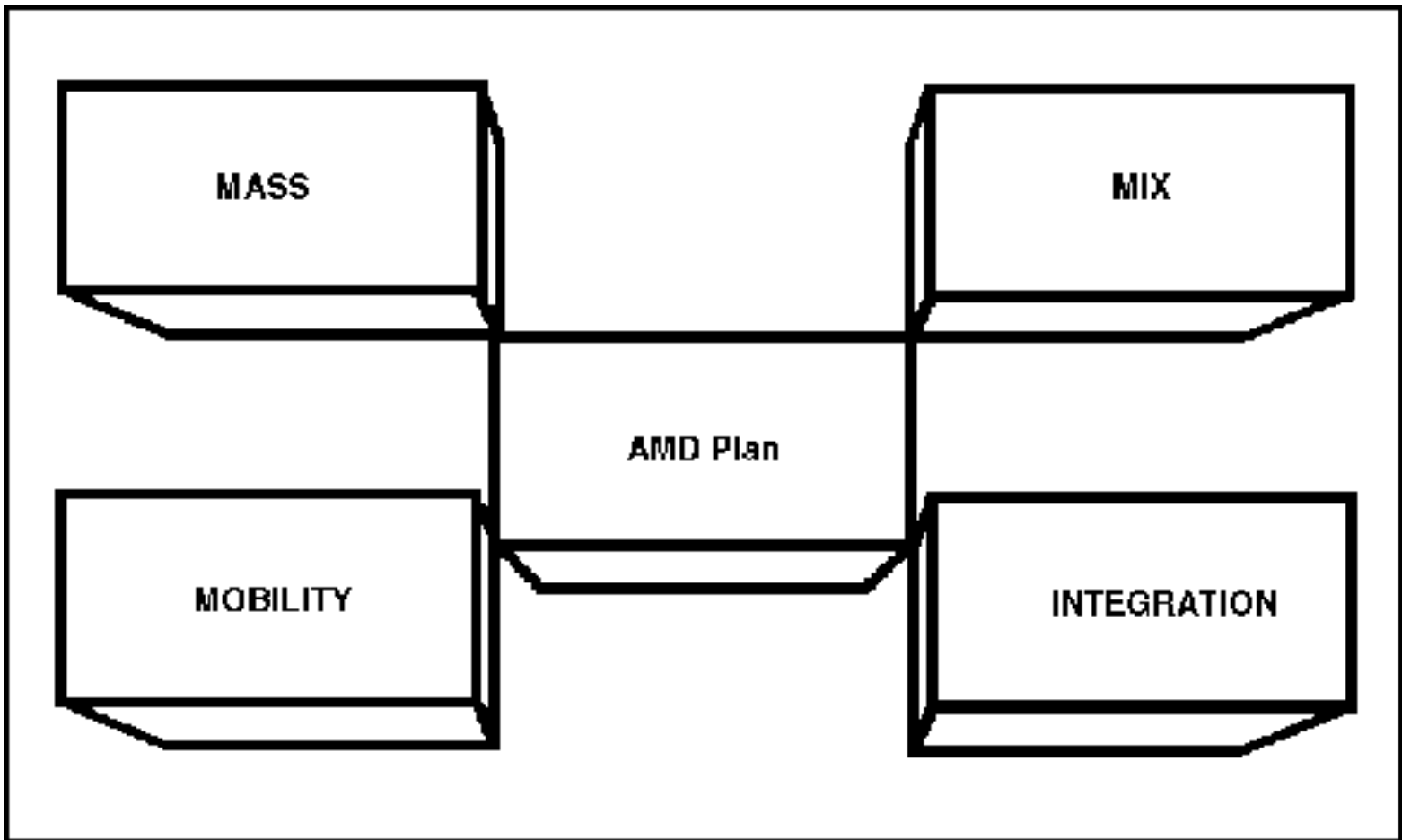

Figure 2-2. Air defense employment principles

ADA EMPLOYMENT GUIDELINES

2-26. In contrast to the brigade, ADA battalion operations orient primarily on designing specific AMD defenses to meet assigned mission requirements. To do this, battalion planners consider the threat to the defended asset, the needs of the defended force, weapon system capabilities, and defense design options. To mass AMD fires anywhere means to accept risk somewhere else. ADA employment guidelines offer the defense design planner options for positioning fire units based on the probability that an enemy air attack on the defended asset will follow a certain avenue of approach. In situations where enemy use of a certain ingress route is predictable, AMD defenses can be arrayed in depth along that route. If the enemy can attack from any direction, then AMD defenses must be balanced to cover all avenues of approach.

DEFENSE IN DEPTH

2-27. Defense in depth is feasible where terrain or other factors clearly canalize air attacks into a definable air avenue of approach (AAA). Defense in depth positions AMD fire units so that the air threat comes under an increasing volume of fire as it approaches the

protected asset or force. For the TMD fight, a vertical defense in depth is achieved through the employment of THAAD and Patriot weapon systems for the two-tier defense.

WEIGHTED COVERAGE

2-28. Weighted coverage is achieved by combining and concentrating fires toward the most likely enemy AAA. A weighted coverage defense accepts some tactical risk in other directions to weight coverage toward another direction.

EARLY ENGAGEMENT

2-29. Early engagement defense positions fire units not only along a likely AAA, but far enough out to engage the threat before their ordnance release line or target acquisition. If sufficient fire units have been allocated to the mission, an early engagement defense is normally part of an AMD defense in depth.

MUTUAL SUPPORT

2-30. Mutual support positions fire units close enough to cover the dead zones of adjacent fire units. Mutual support enables adjacent fire units to mass fires and to protect each other.

OVERLAPPING FIRES

2-31. Overlapping fires engage targets within range of an adjacent AMD fire unit. Overlapping fires enables units to mass fires, but not to protect each other.

BALANCED FIRES

2-32. Balanced fires maximize the ability of an AMD defense to meet a threat attack from any direction. It is achieved by positioning fire units to deliver equal volumes of fire into all AAA. The number of available fire units normally prevents balanced fires defense from massing fires or engaging targets early. Balanced Fires is advisable when enemy AAA cannot be reliably predicted.

THE ROLE OF THE AIR AND MISSILE DEFENSE COORDINATOR

2-33. As the air and missile defense coordinator (AMDCOORD), the ADA brigade commander and representatives in the supported force CP are responsible for AMD planning. The AMDCOORD is an integral member of the commander's staff planning team. The AMDCOORD assists in integrating counterair and TMD priorities into the

force's targeting process. He recommends active, passive, and other combined arms air defense measures in the air defense estimate. The AMDCOORD develops the air defense annex to the supported force's operation plan.

2-34. The AMDCOORD also coordinates with AD elements at higher and lower echelons, as well as adjacent units. Coordination ensures integration of air defense coverage throughout the battlefield. This includes integration with joint or multinational counterair and theater missile defense participants. He may also be responsible for reconstitution activities of the brigade. He cross-levels brigade assets, soldiers, and equipment to ensure that air and missile defense coverage of the brigade remains integrated over the battlefield.

AMD IN THE OPERATIONAL CONTEXT

2-35. The theater commander or JFC focuses on translating national and theater military strategy into a campaign plan. Campaigns are sequences of major operations that arrange tactical, operational, and strategic actions to accomplish objectives. Thus, campaigns are inherently joint. One of the fundamentals of operational art is synergy by which the JFC organizes and combines his forces and action to achieve a concentration of combat power not only at the decisive time and place, but also in the decisive environment.

FUNCTIONAL COMMAND AND CONTROL

2-36. Certain functions are important to operational success, and these can cut across service lines and levels of command. For example, a tightly integrated air campaign serves to provide the JFC with dimensional superiority over the enemy and sets the stage for deep interdiction. The JFC can arrange either symmetrical actions, such as a land force engagement of another land force, or asymmetrical actions, such as a land force engagement of air forces. AMD operations are always asymmetrical and thus have operational significance. This requires the integration of AMD operations into the theater air defense plan. [Figure 2-3](#) shows how ADA brigade operations support the overall theater campaign plan.

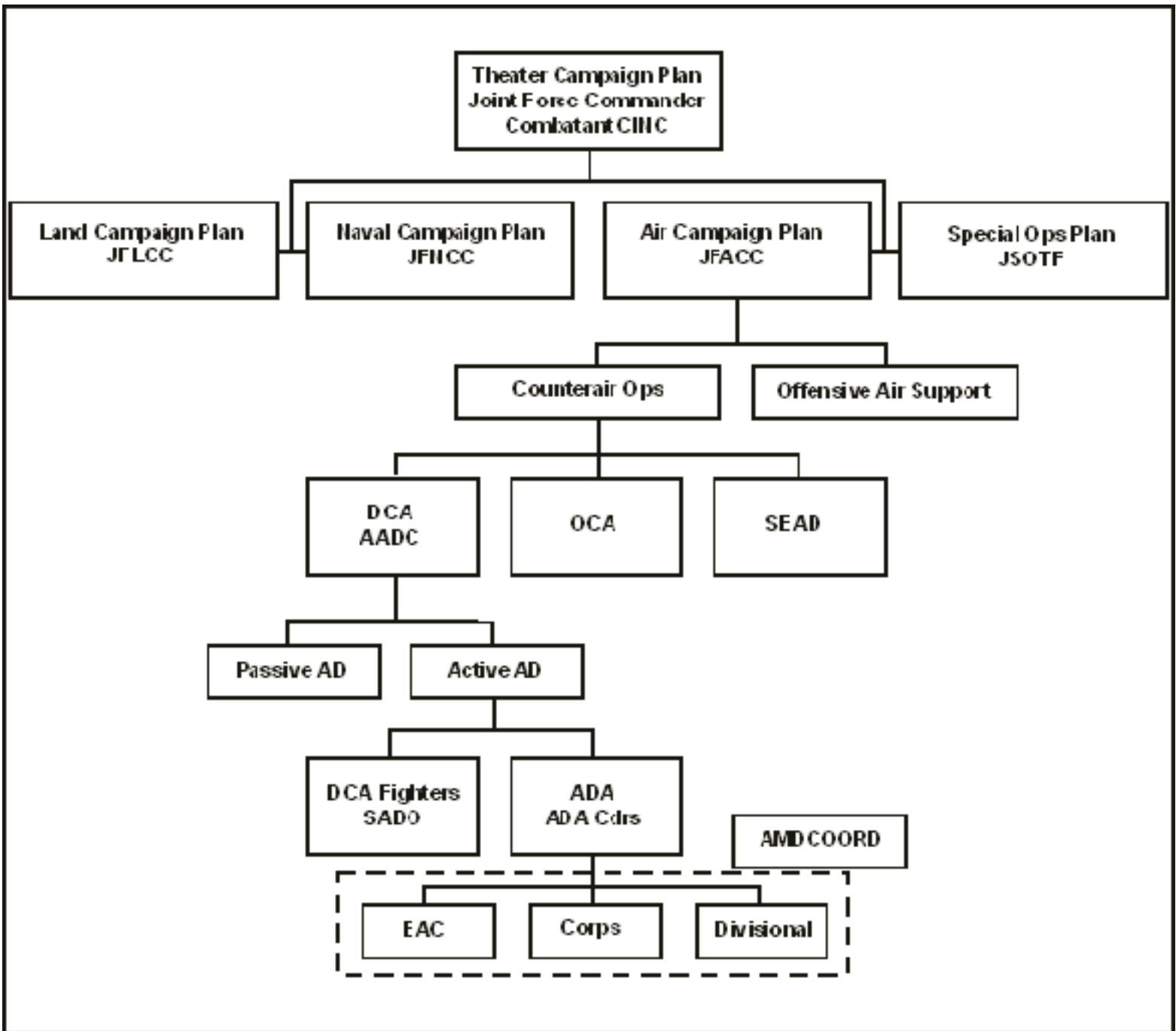

Figure 2-3. AMD Support for Theater Campaign Plan

2-37. To ensure the integration of these critical functions, the JFC may establish functional commanders with command or coordinating authority. The figure shows a joint force organized with functional components rather than service components. The air, land, and naval component commanders in this example are respectively responsible for joint force operations within the air, land, and naval environments. They may also be service component commanders. The JFC may establish support or command relationships between service component elements and functional component commanders. It is important to note that though there are doctrinal norms, the authority of functional commanders is specified by the JFC

FUNCTIONAL COORDINATION OF AIR DEFENSE

2-38. AD plans must be coordinated at all levels to ensure proper integration. The corps commander accomplishes this by delegating coordinating authority to the corps AMDCOORD. Elsewhere within the joint force, there are typically three key decision-makers who coordinate the AD function in the airspace environment: the JFACC, the AADC, and the airspace control authority (ACA). Although organization is based on functional and METT-TC considerations, the AFFOR commander may perform the JFACC, AADC, and ACA functions.

Joint Forces Air Component Commander

2-39. When functionally organized, air operations are commanded by the JFACC. The JFACC normally exercises OPCON of the forces of his own service and is the supported commander for joint air operations. The JFC normally commands forces through service component lines, but the contributions of the elements of other service elements made available can be coordinated via a joint support relationship or under a command relationship, which is usually tactical control (TACON).

Area Air Defense Commander

2-40. The AADC is responsible to the JFC for theater air defense. The AADC develops the procedural and positive controls that guide active AD operations throughout the joint force, including Army corps. The AADC may also be given OPCON or TACON of air or ground based active AD assets. The JFC specifies this authority. Depending on whether the main effort for active AD is force protection or DCA attrition, EAC ADA brigades may be OPCON to the AADC or may be in a joint support role. The AADC promulgates the current joint force air defense warning and weapons control status.

Airspace Control Authority

2-41. The JFC will designate an ACA to regulate the use of airspace in the joint operations area. Proper airspace control not only protects the force but also facilitates rapid identification of enemy air/missile targets. It can shape the airspace through the effective use of airspace control measures. The ACA is the proponent for the JFACC Airspace Control Order (ACO) and has authority to approve all airspace means, including the missile engagement zone (MEZ) for the corps.

JOINT COUNTERAIR OPERATIONS

2-42. [FM 3-01](#) outlines joint counterair doctrine and the ADA role in it. Counterair

operations enable joint offensive air operations by defeating enemy air attacks through joint air defense and interdiction against enemy air assets and supporting infrastructure. Counterair operations continue throughout all phases of the theater campaign until the air threat is eliminated. The purpose of the counterair mission is to attain a desired degree of air superiority to allow freedom of action and protect the force. In the initial phases of theater operations, including entry of the forces into theater, counterair operations play a decisive role in force protection. Only after air superiority is established can the interdiction aspect of the air campaign be initiated. Counterair operations include both offensive and defensive actions. The corps AMDCOORD is responsible to vertically integrate the corps and theater counterair plan within his AO.

OFFENSIVE COUNTERAIR OPERATIONS

2-43. Offensive counterair operations (OCA) attack enemy air capabilities in the air and on the ground. Examples include airfields and forward operating bases, C³ nodes, logistics and infrastructure elements, and electronic warfare assets. The corps AMDCOORD works with the corps G3 Air, the DOCC, and the BCD in some cases, to nominate OCA targets that support corps AD operations. Examples of this can include helicopter and fixed wing forward operating basis and C² nodes. Deep attack assets available to the corps include ATACMS, multiple-launch rocket systems (MLRS), attack helicopters, USAF ground attack aircraft, and special operations forces (SOF).

DEFENSIVE COUNTERAIR OPERATIONS

2-44 Defensive counterair operations (DCA) include both passive and active air defense activities. The ADA brigade conducts active AD, but the AMDCOORD recommends passive AD measures for the force as a whole. Passive AD measures seek to minimize the probability of being acquired by enemy air assets. It also reduces the effects of the air attack after acquisition. Examples include hardening and dispersal of assets, camouflage, signal security (SIGSEC), NBC defensive measures, and attack warning. The objective of active AD activities is to destroy enemy aircraft and missiles and disrupt air and missile attacks. The JFACC may employ both ground based AMD and air superiority fighters.

AMD ROLE IN COUNTERAIR OPERATIONS

2-45. At the operational level, the Army contributes to the theater counterair operations and to theater missile defense. Army combined arms forces provide support for OCA, DCA, and TMD active defense and attack operations. AMD units conduct DCA and TMD operations and help integrate contributions to CA and TMD by other members of the combined arms team. They protect priority forces and assets in the theater base according to the JFC's and JFLCC's counterair and theater missile defense priorities.

2-46. The objective of air defense operations at the tactical level is to protect corps and division forces as they plan and execute battles and engagements. AMD forces control the air environment over the theater, corps, and divisions; protect priority forces and assets from attack and surveillance; provide freedom to maneuver; and destroy enemy aircraft and missiles in the air. Every participant in Army air defense--AMD, maneuver, fire support, aviation, and intelligence--has a role in achieving those objectives, as do the joint forces which support corps and division operations. [Figure 2-4](#) depicts AMD tactical and operational objectives.

OBJECTIVE: GAIN CONTROL OF AIR ENVIRONMENT		
PROTECTIVE: FORCES PROTECTION		
EAC ADA	CORPS ADA	DIVISION ADA
Control air environment	Provide freedom to maneuver	Protect maneuver and other key assets
Protect the force	Protect key assets	
Preserve nuclear options	Protect reserve	Provide freedom to maneuver
Protect DCA airpower	Reinforce divisions	
Protect reinforcing assets		
Protect sustainment		
Protect C ²		

Figure 2-4. AMD Tactical and Operational Objectives

2-47. Operational art links success in tactical engagements and battles with strategic aims. The aspects of battle dynamics establish this relationship: battle command; battlespace; depth and simultaneous attack; early entry, lethality and survivability; and combat service support (CSS).

2-48. Operational protection conserves the fighting potential of a force so that it can be applied at the decisive time and place. Operational protection includes actions taken to counter the enemy's firepower and maneuver by making soldiers, systems, and operational formations difficult to detect, strike, and destroy. Operational protection pertains to forces everywhere in the theater of war or operations. Operational protection includes, but is not limited to the following activities.

- Providing operational air defense
- Conducting deception
- Protecting operational forces and means
- Employing OPSEC
- Providing security for forces and means
- Conducting rear operations including combating terrorism
- Conducting risk assessments
- Planning for possible response or use of weapons of mass destruction (WMD)

PRIORITIZING THE AIR DEFENSE EFFORT

2-49. The JFC identifies the main effort for air operations in terms of an apportionment decision where percentages of available air and AD assets are apportioned to the various missions of strategic attack, interdiction, close air support (CAS), counterair, and maritime support. The JFACC must--but the JFLCC and JFNCC may--submit apportionment recommendations to the JFC. Apportionment impacts on AMD operations because the JFACC may seek to compensate for a lack of apportioned DCA assets with taskings to ground AMD units. The corps or EAC TAAMDCOORD can develop recommendations for apportionment to be provided by the Army service component commander (ASCC) or JFLCC to the JFC.

2-50. Priorities are often confused with missions, but they lack most of the specifics of a valid mission statement. AD priorities, like airpower apportionment, are tools used by the JFC and subordinate commanders to establish the overall priorities of effort for the joint force. At the brigade level, they are described in terms of a critical combat function such as maneuver or an activity such as a river crossing, rather than a specific asset. The AMDCOORD develops AD priorities for the commander. AD doctrine outlines four criteria for developing AD priorities:

- **Criticality:** how critical is the asset/function to the operations?
- **Vulnerability:** how easily can the asset/function be damaged by air and missile attack or observed by aerial sensors?
- **Recuperability:** if attacked, how easily can the asset/function be restored?
- **Threat:** does the enemy desire to attack this asset/function?

[Figure 2-5](#) illustrates how the AMDCOORD recommends AD priorities.

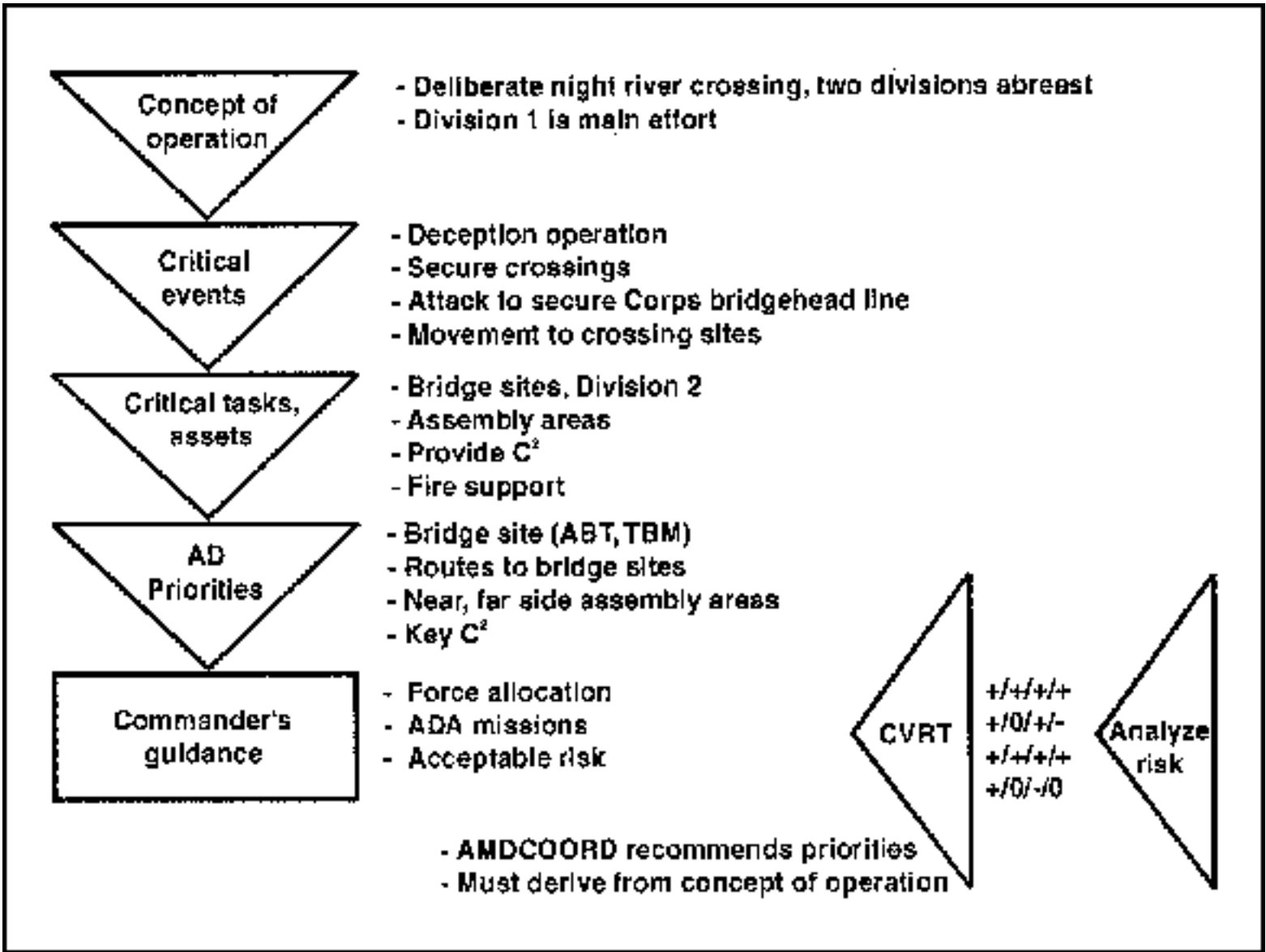

Figure 2-5. Recommending AD Priorities

2-51. Once the AD priorities have been approved, the AMDCOORD develops the AMD mission. [Figure 2-6](#) illustrates how the AMDCOORD develops AMD missions.

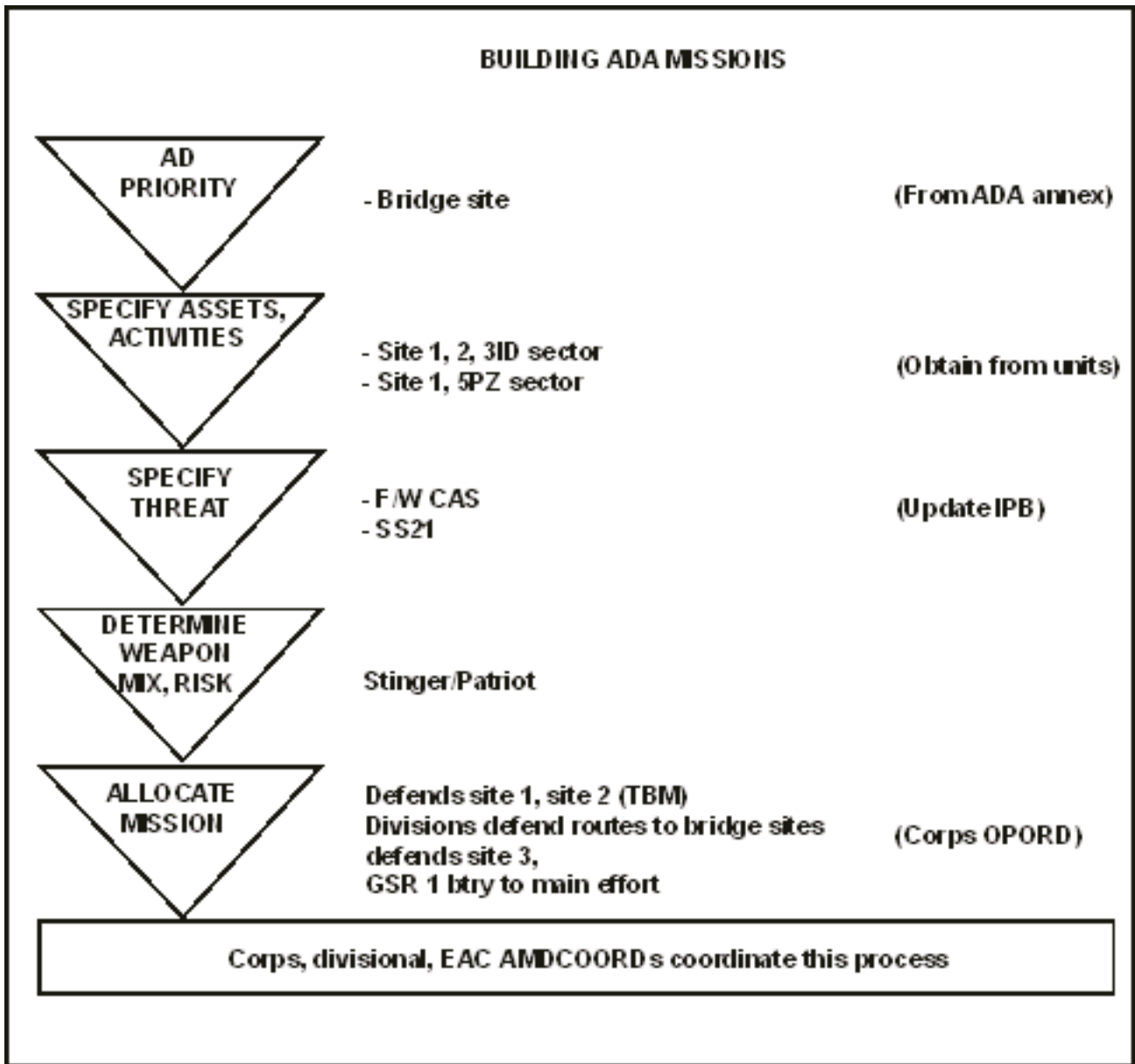

Figure 2-6. Developing AMD Missions



[RDL](#)

[Table of](#)

[Document](#)

[Download](#)

[Homepage](#)

[Contents](#)

[Information](#)

[Instructions](#)

Chapter 3

ADA Brigade in Force Projection Operations

Force projection usually begins as a rapid response to a crisis somewhere in the world. However, it may involve a deliberate, slow buildup, and deployment. This chapter outlines the requirements for ADA brigade and subordinate unit commanders to execute a force projection operation. Force projection operations range from mobilization and deployment of forces to redeployment and, in some cases, demobilization. Force projection operations are usually executed in general stages. ADA brigade commanders may be required to have units in more than one stage at a time.

MOBILIZATION

3-1. Mobilization is a process in which all or part of the armed forces are brought to a state of readiness for war or other national emergency. This includes activating all or part of the reserve component (RC) or National Guard (NG). Strategic mobilization includes industry. There are five levels of mobilization whose process is continuous but not necessary sequential. The levels are:

- Selective mobilization
- Presidential selected reserve call-up
- Partial mobilization
- Full mobilization
- Total mobilization

3-2. The mobilization phase places demands on the ADA brigade to expand in order to meet the mobilization requirements of units, personnel, and equipment. While the ADA brigade may have no specific responsibilities for mobilizing RC or NG forces, the brigade commander may want to follow the mobilization of his war-trace battalions. It is during this phase that the brigade identifies its needed resources. [FM 3-35](#) provides specifics on the Army's mobilization process.

PREDEPLOYMENT ACTIVITY

3-3. Predeployment activities and mobilization generally occur simultaneously. Both begin with an alert process that sets into motion actions necessary for deployment and subsequent employment of forces. Predeployment activities include planning, organizing the brigade's forces, and preparing personnel and equipment for deployment.

3-4. Predeployment activities involve the actions that must be taken before a unit can deploy. The deployment can involve anything from an emergency deployment readiness exercise (EDRE) to a force projection operation such as Desert Shield/Storm. It is imperative that leaders are ready to deploy at any time. Predeployment tasks must be practiced during normal training periods. After the alert is initiated, the conduct of the predeployment activities should only be a review.

3-5. Successful force projection capabilities rely on fully trained, well-led, properly equipped and sustained units and soldiers. Predeployment activities bring together the ADA active component (AC), RC, and NG organizations under the control of the ADA brigade. At this time the brigade prepares for force projection. The lift requirements are planned based on the operation's METT-TC. The time-phased force and deployment data list (TPFDDL) is prepared. ADA brigade units are brought to strength in personnel and equipment.

DEPLOYMENT

3-6. Deployment is the movement of forces and their support bases from any location to an AO in response to a military need or crisis. Contingency and or exercise movement plans are required for all units that are listed in an approved contingency or exercise plan when the exercise directive requires a movement plan. Exercise movement plans will not be filed with contingency/mobilization/deployment movement plans. The movement of troops and equipment to any location in the world is described as deployment. This movement of troops and equipment can be in large or small quantities. ADA units must be prepared at all times for any type of deployment. Equipment deployment, movement control, operation of ports and airfields, leader training, individual training, and personnel deployment are significant areas requiring a leader's personal attention in planning and execution. Rail, truck, aircraft, or ship can move troops and or equipment. Coordination with the transporting agency must be accomplished to ensure timely, complete, successful, and efficient deployment. Leader and individual training are conducted simultaneously after the departure of equipment and prior to the personnel deployment. Individual training should consist of a review of basic soldier skill tasks for the soldiers. Leader training is conducted while individual training is conducted with soldiers. This involves gathering as much information on the threat as possible prior to troop deployment and to begin mission planning. Having access to the actual mission allows for mission analysis, a tentative plan, subunit planning, back briefs, war gaming, and plan adjustments. This must occur prior to entering the theater of operations. Having the mission information saves time on

preparation to enter the AO.

3-7. Deployment movement plans are required for all AC units and RC units who are identified under the pre-positioned materiel configure in units sets (POMCUS) program or assigned a direct or modified deploying mission. All other RC units except non-deploying units will prepare a modified deployment plan to be filed as an addendum to the mobilization movement plan. Commanders will determine the type of plan or plans to be written based on the operations plan (OPLAN), which corresponds to the unit's primary CAPSTONE mission. Typical information available from the time-phased force and deployment list (TPFDL) includes mode of transportation, port of embarkation (POE), port of debarkation (POD), and the latest arrival date (LAD) on which a unit can be delivered at the POD. The information on the TPFDL can be acquired through the S-3/G-3 channels that in turn access the TPFDL through the installations' worldwide military command and control system (WWMCCS) terminal. The intelligence officer (S2) or civil affairs officer (S5) should be prepared to brief a country orientation for the area of deployment. This should include information ranging from climate to threat.

3-8. The deployment of the corps ADA brigade elements may occur after or concurrent with the deployment of an EAC ADA brigade and AAMDC. The deployment will be a phased activity to bring the right balance of corps forces into the AO. The deployment period is focused on staging or assembling units and associated equipment at the appropriate air or seaport.

ENTRY OPERATIONS

3-9. Entry is the sequencing of forces into an AO. The ADA brigade arrives into the AO as either an entry force or as a follow-on force. Entry operations may be opposed by an enemy or may be unopposed. It is important to note that each entry option reflects a different set of strategies, operational, and or tactical requirements affecting the level of sustainment support required. The logistics functions of manning, arming, fixing, fueling, moving, and sustaining the soldier apply to the following operations. Entry operations is a phased build-up of AAMDC and brigade units, personnel, and equipment equal to the projected threat and is generally comparable to the element of the size of the joint/combined force being supported. It can be an overt or a covert operation. The expansion and build-up of the lodgment is completed prior to launching the entry operation to secure deep operations. The corps ADA brigade will move forward with the corps into decisive operations to gain deep objectives. The sustainment activity increases in tempo to support ADA brigade activities.

UNOPPOSED ENTRY

3-10. Unopposed entry is entering the theater peacefully with the assistance of the host

nation. Early deploying units may flow through airports or seaports into a lodgment area. From this area they assist forward-presence or host nation forces, protect the force, reconfigure, build combat capability, train, and acclimate to the environment. Entry during stability operations and support operations will normally be unopposed. However, even in this apparently benign entry operation, protection of the force remains a critical command consideration. The unopposed entry places a lower personnel and equipment logistics burden on the AAMDC subordinate ADA brigades. Combat losses probably will be less during the force projection. The unopposed entry is the preferred type of entry. Unopposed entry planning requirements are initial force projection and sustainment.

OPPOSED ENTRY

3-11. Opposed entry requires forces to deploy into a theater prepared for combat operations. If the circumstances are right, the entry and combat operations stages could combine in a "coup de main", achieving the strategic objectives in a single major operation. The operation is at greatest risk during opposed entry operations in which units move directly to combat operations. Often this will be the first contact between US forces and the enemy. Early entry forces may have to move immediately to combat operations to take advantage of an opportunity, protect the force, or even conduct retrograde operations to gain time for additional force buildup. Opposed entry operations require the full synchronization of joint capabilities in order to place large ground forces in the theater. In opposed entry operations, units, personnel, and equipment are required at a higher number and faster rate because of the level of attrition and combat losses. It ends when initial objectives have been completed and the lodgment is secured. At this time reconstitution of forces if required, is completed before the next phase begins. This phase could be offensive or defensive operations. Opposed planning requirements are:

- Initial force projection requirements
- Phase/Stage/Campaign force projection requirements
- Sustainment requirements

3-12. The opposed early entry could include the initial assault force projection and the follow-on force projection. The consumption of personnel, supplies, and equipment by enemy action could place a greater demand on the sustainment activities.

OPERATIONS

3-13. Operations comprise actions that lead to or directly contribute to accomplishing the combatant commander's mission. The operations phase of force projection may occur immediately or after a long buildup.

ADA OBJECTIVES

3-14. The ADA objectives focus on preserving combat power while repelling aerial threats, gaining the initiative, and supporting the offense. Air and missile defense objectives are the same for established theaters as they are for force projection operations. Joint counterair and ADA brigade air and missile defense participants fill various roles to achieve these objectives. The ADA objectives include theater missile defense, air breathing threat defense, and surveillance planning. The specific theater missile and air defense and surveillance planning objectives are described below.

Theater Missile Defense

3-15. The purpose of the TMD is to counter the TM threat by coordinating and integrating the four operational elements, or pillars, of TMD into cohesive and coherent combat operations. FM 3-01.12, Army Theater Missile Defense Operations, provides more details of the Army's TMD operations. Army TMD requires strategic, operational, and tactical intelligence information to accomplish interception of missiles in the upper tier. The purposes are achieved by:

- Deterring hostile nations from employing theater missiles
- Deterring launch of theater missiles against US forces, US allies, and other strategically important countries including areas of vital interest
- Protecting US forces, US allies, other important countries, and areas of vital interest from theater missiles launched against them
- Reducing the probability of theater missile attacks and minimizing the effects of damage caused by them
- Detecting, warning of, and reporting enemy theater missile launches

Aircraft Defense

3-16. The purpose of aircraft defense is to accomplish destruction of rotary-wing (RW), unmanned aerial vehicle (UAVs), cruise missile (CMs), and fixed-winged (FW) penetrators. The aircraft defense design must be integrated with TMD. Air breathing threat (ABT) defense includes the following:

- Detection of potential threat (UAVs, RWs, CMs, FW penetrators)
- Identification of unknown objects
- Interception of enemy forces
- Destruction or nullification of enemy weapons

Surveillance Planning

3-17. The surveillance planning objectives are required for the surveillance role. These

planning objectives are provided below:

- Strike the enemy as soon as possible
- Subject the enemy to pressures of increasing intensity of forces and diversity of weapon systems as the target approaches the engagement zone
- Keep the enemy under surveillance and attack as long as it remains threat

CORPS AREA AIR DEFENSE

3-18. The corps ADA brigade commander is responsible for the corps area air defense (CAAD). This responsibility is a proactive operation with attack and defense components.

Attack Operations

3-19. CAAD contributes to attack operations by providing intelligence on enemy TMD activities allowing friendly forces to be first to fire and first to destroy the enemy. This is an offensive principle based on effective and efficient defense design. Attack operations implement the thrust of all ADA fundamentals. CAAD attack operations are based on effective command, control, communications, and intelligence (C³I).

Defensive Operations

3-20. CAAD defensive operations are based on active defense measures. Direct action is taken to destroy or reduce the effectiveness of enemy air operations. It includes the use of aircraft, surface-to-air weapon systems, electronic attack (EA), and non-ADA weapons used in an air defense role (refer to [FM 3-01.8](#)). It includes the following types of defenses.

- **Static Point Defense.** A posture designed for the protection of a more limited area, normally in the defense of the vital elements of a force and or the vital installations of the rear area. A static point defense is characterized by priority of defense being given to specific assets. Generally, a static point defense is applicable to geopolitical targets (population centers, APOD, SPOD, bridges, power grids, utilities, dams) or fixed military installations.
- **Mobile Point Defense.** A posture designed for protection of military organizations during force operations. A mobile point defense is characterized by priority of defense being given to specific military organizations in the execution of combat operations.
- **Area Defense.** A posture designed for the defense of a broad area. Airborne AD resources have primary responsibility for providing area air defenses because of their flexibility, range, mobility, and reusability. In an area defense, no particular asset(s) receives priority of defense.
- **Passive air defense.** All measures other than active air defense taken to minimize

the effects of hostile air action. These include, but are not restricted to, the use of cover, concealment, camouflage, dispersion, and protective construction.

Surveillance Defense Measures

3-21. The ADA brigade participates in the C³ countermeasure strategy to deny the enemy information. This is a proactive strategy designed to protect friendly high value targets (critical assets) from enemy attack, information gathering, or deception techniques. The objective is to deny, negate, or destroy enemy surveillance of the corps strength and disposition.

Offensive operations

3-22. Offensive operations or attack operations are susceptible to information gathering by the threat. Therefore, OPSEC is dependent on friendly counter-countermeasures for surveillance attack operations. These measures are the physical destruction and or jamming of surveillance craft and the full employment of our sensors, including AWACS, control and reporting post (CRP), control and reporting center (CRC), TMD radars, Patriot radars, and SHORAD radars

Defensive operations

3-23. The ultimate objective is to seize the initiative and, thereby, making offensive operations allowable. Active defense operations provide protection from surveillance by the fully coordinated use of lethal assets to suppress, neutralize, or destroy airborne surveillance craft. Passive defense measures protect combat forces and assets by reducing the probability of effective enemy surveillance. It includes the practice of OPSEC and the establishment of a countersurveillance program. It includes any action to minimize the effects of enemy surveillance including cover, concealment, camouflage, dummy positions, and dispersion.

COMBAT OPERATIONS

3-24. In combat operations, the JTF at some point decides to move against the enemy. This point in time may be predetermined and stated in the mission plan or it may be tied to specific enemy actions. Employment options are affected by friendly forces on the ground, the type of terrain, and the disposition of the enemy. As the operations begin, the commander assembles sufficient combat power to win the decisive victory.

3-25. The combat operations supported by the corps ADA brigade require the movement of forces forward to support the attack. This provides maximum ADA protection to the corps while in the offense. The EAC ADA brigade coordinates with the corps ADA

brigade to ensure that the ADA protection of the theater of operations is not degraded by corps units moving forward. During combat operations, the ADA brigade conducts offensive, defensive, and other operations detailed in subsequent chapters of this manual.

WAR TERMINATION AND POST CONFLICT ACTIVITY

3-26. Successful combat operations are designed to bring an end to the war. When a cessation of hostilities or a truce is called, deployed forces transition to a period of postconflict operations. This transition can occur even if residual combat operations are still underway in parts of the theater of operations.

WAR TERMINATION

3-27. War termination results when the combat force takes up defensive positions. These defensive positions could be non-linear or linear.

POST CONFLICT ACTIVITY

3-28. The ADA brigade participates in restoring order. It actively maintains its mission of providing protection to the theater from the TM threat and ABT. It begins preparing selected ADA brigade units for redeployment. The post conflict period could also address activities identified as Support Operations and Stability Operations.

RECONSTITUTION AND REDEPLOYMENT

3-29. This phase's objective is to redeploy no longer needed assets. Redeployed forces may be sent back to CONUS or prepared for deployment to a new station or theater. The redeployment is supported by reconstitution activities. Both activities require planning to include the allocation of lift support, accountability, and packaging. Redeploying forces require protection.

RECONSTITUTION

3-30. The ADA brigade reconstitutes its assets during decisive operations. Reconstitution also occurs at war termination and before redeployment.

REDEPLOYMENT

3-31. The ADA brigade assets redeploy in parallel to the drawdown of the corps. Protection against enemy TM or ABT attacks is provided throughout the redeployment.

DEMOBILIZATION

3-32. Demobilization must be planned for and executed. The demobilization must meet the commander's intent and air defense focus. Redeployed units to CONUS that are identified for demobilization require the following activities:

- Personnel and equipment are checked out.
- Personnel will be returned to the reserve component and civilian life.
- Equipment will be inspected and properly classified.
- Units will be returned to control of the reserve component.



[RDL](#) [Table of](#) [Document](#) [Download](#)

[Homepage](#) [Contents](#) [Information](#) [Instructions](#)

Chapter 4

Battle Command

This chapter provides the doctrine for battle command on the modern battlefield. ADA brigade commanders must assimilate thousands of bits of information to visualize the battlefield, assess the situation, and direct the military action required to achieve victory. Thinking and acting are simultaneous activities for leaders in battle.

ROLE OF THE COMMANDER

4-1. The command function motivates and directs the force toward accomplishing the mission. It is a continual process centered on the commander. The commander is selected for his ability as a military leader, as a tactical expert, and for his ability to organize and direct the efforts of his unit. The commander is personally responsible to accomplish his unit's mission. To do this, the commander is vested with command authority and assisted by a staff and a command facility. Depending on the mission, he has command authority ranging from full authority to temporary or highly constrained authority.

COMMAND AND CONTROL ORGANIZATIONS

4-2. The C² combat function underpins all other combat functions. Battle command is the motivating force behind all military action. Effective control ensures the implementation of commands and provides accurate situation awareness to the commander. The commander must be both a good leader and an effective decision-maker. He is reliant on a functional C² system to identify decision points, to provide sound options, and to ensure the implementation of decisions.

FORCE, ENGAGEMENT, AND SUSTAINMENT OPERATIONS

4-3. C² of ADA brigade operations is grouped into force operations, engagement operations, and sustainment operations. Force operations set the conditions for success by effecting the tactical planning and execution required to make battle-ready fire units available at the right place and time. Engagement operations involve the conduct of the air

battle and the accomplishment of the AMD mission by defeating enemy aircraft and missile attacks. AMD operations are sustained over time through effective logistics and force projection operations. Chapter 8 covers ADA brigade sustainment operations.

COMMAND POSTS

4-4. The CP is the facility from where the commander and his staff command and control operations. ADA CPs are established down to HIMAD battery and SHORAD platoon levels. For survivability, alternate CPs are normally established at brigade and battalion level. All CPs have secure communications to higher headquarters. CPs maintain current situation awareness regarding the national alert status, the status of enemy and friendly forces, their own unit status and applicable orders in effect. CPs must be able to execute current operations and to pass orders to subordinate ADA units. CPs have dedicated elements to implement emergency survivability measures in case of chemical or ground attack. CPs can sustain operations indefinitely through crew rotation.

Brigade Command Post

4-5. The brigade CP is organized with an Air and Missile Defense Planning and Control System (AMDPCS) and a FDC. The AMDPCS performs FO and EO functions. The CP includes an operations/Intel cell, an S1/S4/log cell, and a plans cell. The S1/S4 and S2/S3 cells may or may not be collocated. FDC manages AMD engagement operations and is normally collocated with the AMDPCS. Engagement operations provide important feedback to the AMDPCS affecting current operations and future plans. The corps ADA brigade CP often positions near the corps main CP but must be mobile enough to move and locate throughout the corps area of operations. The EAC brigade CP locates in a position to best influence the theater AMD mission.

S2/S3 Current Ops

4-6. The S2/S3 Current Ops Cell executes current force operations and maintains an accurate awareness of the current situation for the brigade commander. To do this, it maintains constant communications with brigade LNOs, the CADE, division and EAC CPs, and subordinate battalion CPs. All brigade orders are issued from this cell, and copies of all relevant orders and directives from higher, adjacent, and subordinate CPs are maintained here. The focus of S2/S3 activities is in answering the commander's critical information requirements (CCIR) and his priority intelligence requirements (PIR).

S2/S3 Future Ops

4-7. This element performs future planning and prepares risk assessments, incorporating risk control measures in all plans. The ADA brigade planning horizon may vary from 24 -

96 hours in the future, depending on the tempo of operations. The Plans cell synchronizes AMD operations in time with other combat functions and adjacent forces. ADA brigade planning focuses mainly on allocating forces to missions and on developing an AMD scheme of maneuver to maintain area AMD coverage of the force as it maneuvers. In the corps ADA brigade, the plans cell coordinates closely with the CADE, the corps plans element, divisional ADA planners, brigade LNOs, and subordinate battalion staffs.

FDC

4-8. The brigade FDC provides fire direction to subordinate battalions' fire direction sections (FDS). The FDC maintains positive control links with both higher and lower air defense C² centers. The FDC provides expertise and staff input concerning airspace management, HIMAD capabilities, C³ linkages, and engagement operations tactics. The FDC ensures that ACOs are disseminated promptly to subordinate battalions.

S1/S4 Cell

4-9. The S1/S4 Cell executes CSS within the Brigade, including supply, maintenance, transportation, and field services support. It focuses primarily on sustaining weapon systems. It interfaces with the corps support command (COSCOM) and the theater army area command (TAACOM) headquarters and area support groups, the corps staff, and subordinate unit logistics elements. The S1/S4 cell coordinates logistics movements across EAC, corps, and divisional transportation routes. In coordinating ammunition resupply, the S1/S4 Cell must coordinate with supply and transportation elements and with division ammunition officers for ammunition shipments into division sectors.

4-10. [Figure 4-1](#) shows an example of the brigade CP layout. Commanders will determine the best design for their mission and operation.

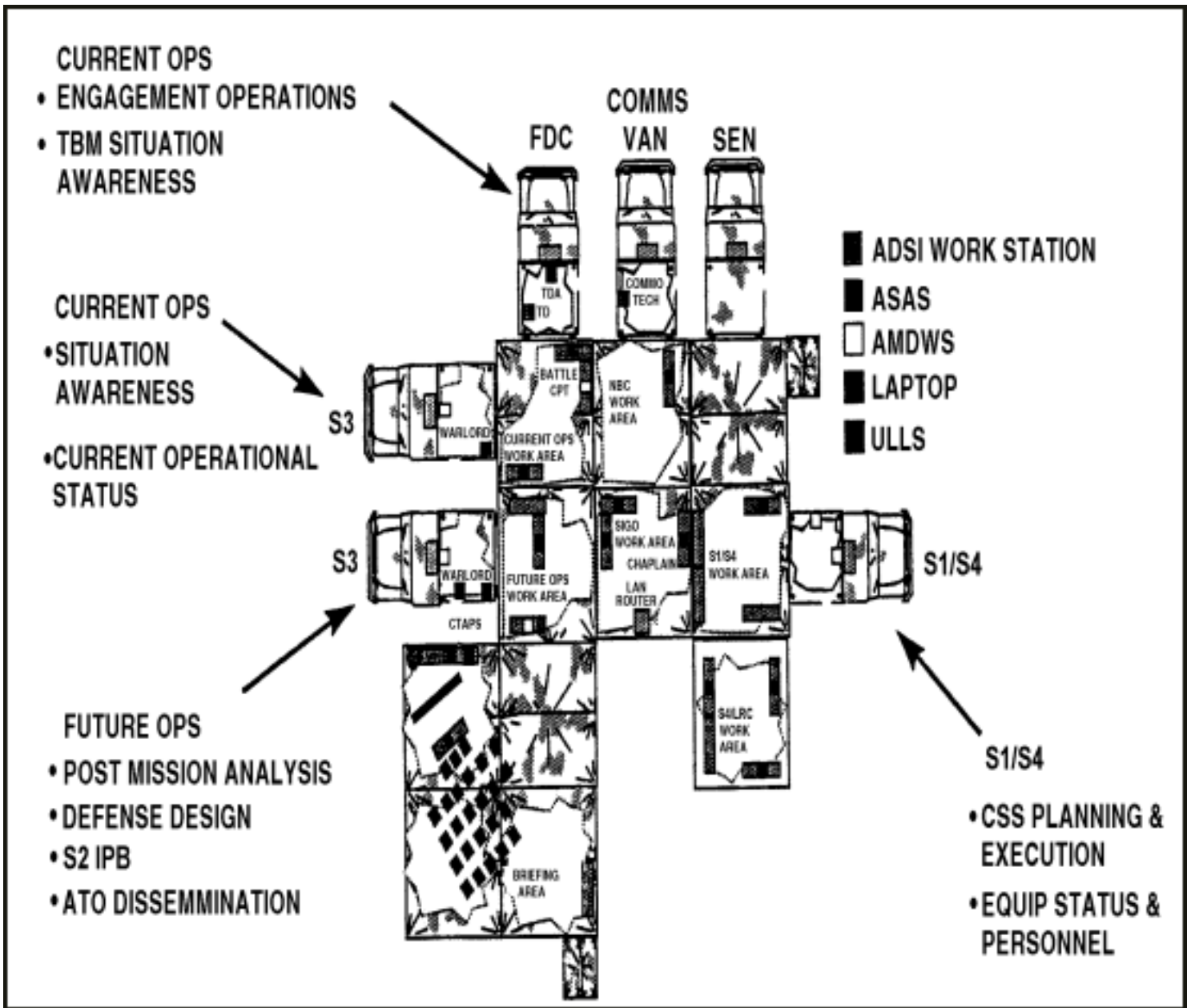

Figure 4-1. ADA Brigade Command Post

Battalion Command Posts

4-11. ADA battalion CPs are organized to perform liaison and other functions similar to the Brigade CP. HIMAD battalion CPs have an AMDPCS and a FDC, while SHORAD battalion CPs have an AMDPCS and an air battle management element (ABME). Battalion operations focus on assigning missions, developing detailed SHORAD/HIMAD defense designs, conducting AMD engagement operations, and on sustaining crews and units.

Battle Staff

4-12. A well-organized CP is an essential prerequisite for C², but the real engine of the C²

process is the battle staff. The battle staff consists of the staff principals and assistants who are directly responsible to the commander. Battle staff members are functional area experts, trained to rapidly work as a team through the staff estimate and staff planning process. The battle staff receives the commander's guidance and quickly provides a recommended plan of action.

Adjacent and Higher Command Posts

4-13. In integrating AMD operations into the theater air defense system and synchronizing with corps operations, the ADA brigade must interface with many other CPs. It is important that the battle staff understand how functions impacting on AMD operations are performed in these headquarters.

Corps Command Posts

4-14. The corps ADA brigade receives its orders from the corps headquarters. Additionally, in large unit operations, a JTF may hold a corps in reserve and task it with responsibility for tactical rear operations. In this case, the corps may have OPCON of EAC units conducting tactical operations in the theater rear. These include EAC ADA brigades. Division CPs are organized similarly to the corps CP, but on a smaller scale. The corps conducts operations from three CPs.

4-15. The TAC CP serves as a mobile alternate CP and monitors the close fight in coordination with division CPs. It normally locates in the division rear area and is headed by the corps chief of staff with a small battle staff. The Rear CP conducts sustainment and rear battle operations in coordination with the COSCOM and the rear area operations center (RAOCs). The Rear CP is headed by the corps deputy commanding general (DCG) and manned by a large staff element to perform essential combat, CS, and CSS functions.

4-16. The Main CP conducts future planning and the synchronization of close, deep, and rear operations. The corps commander and general staff principals operate from this CP. The corps DOCC also operates from the Main CP. TMD attack operations, AMD nominations for OCA targeting, and other activities are coordinated through the DOCC.

4-17. The corps air defense element (CADE) coordinates corps air and missile defense operations much like the corps fire support element (FSE) coordinates fire support operations for the corps. The CADE is represented at the corps command posts. The CADE works for the corps ADA brigade commander, who also serves as the corps AMDCOORD.

Air Operations Center

4-18. The JFACC is often also the ACA, AADC, and AFFOR. The JFACC CP includes a

general staff element that conducts future planning and S1/S4 coordination and an air operations center (AOC) which executes the air campaign plan. The principal execution document for air operations is the daily air tasking order (ATO), which is developed over a three-day period. It addresses all aspects of the air operation, including air defense fighter operations. It is published with an attached ACO which outlines the supporting airspace control plan for the day. The AOC's mission is to develop, refine, and execute the ATO. Component mission and weapon experts assist the AOC. The AAMDC commander, as the DAADC, serves the AOC as the Army component mission expert for active defense and TMD operations.

Battlefield Coordination Detachment

4-19. JFLCC interests in the ACC headquarters are represented by a large liaison section termed the battlefield coordination detachment (BCD). These interests normally include the coordination of deep fires, airspace control means, air defense operations, and normal air-ground liaison functions. The BCD is staffed with dedicated intelligence, operations, aviation, airspace management, AMD, and fire support experts. Depending on the situation, it may be augmented with corps LNOs, including ADA officers. If the corps is also functioning as a JTF, then the corps forms the BCD. Corps AMD coordination with the ACC is accomplished through the BCD. The BCD collocates with the AOC. The ADA brigade coordinates with the JFACC through its higher headquarters and the BCD. BCD air and missile defense coordination in turn will include ACC air defense planners and Army AMD component experts augmenting the AOC. FM 3-100.13 describes BCD doctrine. [Figure 4-2](#) shows the organization of the AOC and how the BCD is integrated.

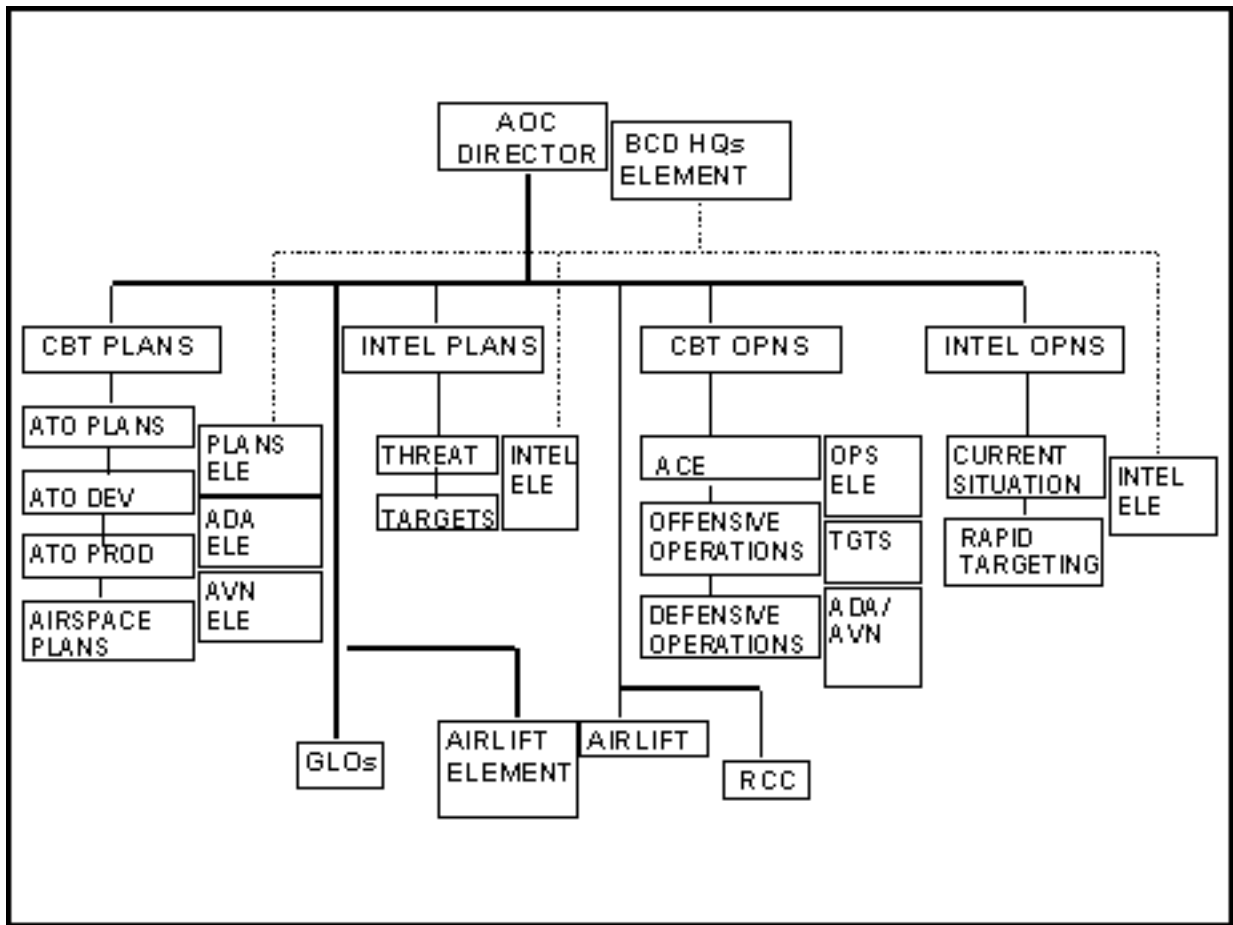

Figure 4-2. BCD/AOC Organization

Field Army/Land Component Commander Command Post

4-20. A numbered army may command up to five corps in large unit operations. The Eighth US Army in Korea is an example. A field army commander may be the Army forces commander within a joint force or task force. Third US Army is the ARFOR for USCENTCOM. Within a joint force, it could also be a functional land component headquarters commanding all land forces. In smaller operations, the corps could be the ARFOR or LCC. In some cases, there is precedence for an Army division to be a JTF ARFOR.

EAC ADA Brigade

4-21. If the AAMDC is not present, the EAC ADA brigade coordinates with an ARFOR/LCC/Army level headquarters in several areas. If not task organized by the JFC as OPCON to the JFACC, the EAC ADA brigade will receive missions from this headquarters. If OPCON to the JFACC, the brigade must still coordinate AMD defenses with an Army level headquarters, as well as logistics, communications, and rear area security matters. In the initial entry stage of force projection operations, the corps ADA brigade may be OPCON to the gaining ARFOR headquarters. The corps may be the

ARFOR. In these instances, the corps ADA brigade may also coordinate directly with an Army headquarters.

Operations and Organizations

4-22. [FM 3-50](#) outlines Army level operations and organizations. The Army conducts deep fires, air defense, airspace management, and other functions of relevance to AMD, but it does so on an operational level. Issues to be coordinated at army level include submission of airspace, OCA interdiction, air defense requirements, TMD missions, and joint force air apportionment recommendations. In the absence of a subordinate corps or similar headquarters, the field army can perform limited tactical functions in the theater rear. The EAC ADA brigade coordinates both with the army headquarters and with its BCE element in the AOC. The corps ADA brigade coordinates army level AMD issues through the corps as necessary.

Army Service Component Command

4-23. In World War II, large unit operations in the European theater included dozens of corps, each commanding from two to five divisions. Span of control requirements necessitated not only the formation of field armies to command corps, but army groups to command field armies and up to 25 corps. Today, the mobility and combat power of an army corps and supporting air forces are vastly greater than their antecedents of fifty years ago. This has made the prospect of requiring an army group headquarters very unlikely. Nevertheless, the theater requirements for operational level support to multiple corps has remained, leading to the constitution of Army Service Component Commander (ASCC). This position was formerly termed theater army commander. The ASCC is responsible for carrying out US Title 10 support within a theater of operations.

4-24. ASCC roles can range from force provider in a transition to war, to operational headquarters in a force projection operation, to national support headquarters in a period of conflict. US Army Europe headquarters is an example of an existing ASCC. In peace, the ASCC mission is to provide trained and ready forces in support of combatant commanders. In a force projection scenario, the ASCC focus is upon receiving, assembling, and moving the ARFOR quickly to its employment area of operations. In addition to logistics support, this mission may include force protection. The resulting ASCC task organization might include SOF and combat units such as AMD. The ASCC might also command a numbered army in this situation, if specified by the combatant CINC. In combat, the ASCC provides the full range of operational level CSS and rear area tactical CSS to the ARFOR, allowing the CINC to strategically concentrate land forces. In all cases, the ASCC is an essential link between the combatant commander, the host nation, and the ARFOR. [FM 3-50](#) describes ASCC organization and functions in detail. AMD coordination with an ASCC will depend on the situation, but could include logistics, intelligence, operational missions,

and deployment/redeployment issues.

Logistics Command Post

4-25. The ADA brigade coordinates with some or all of the following CPs to obtain logistics support. The ADA brigade coordinates with the COSCOM/TAACOM/DISCOM CP for support of broad logistics support priorities and arrangements. It coordinates with the COSCOM Materiel Management Center for supply and maintenance priorities. It coordinates with corps and EAC Area Support Groups (ASG) for specific CSS support. It coordinates with corps and divisional movement control centers for movement and transportation support. Chapter 8 describes the CPs and the support they provide.

Control and Reporting Center

4-26. The AADC will establish one or more subordinate C² facilities to execute air and air defense operations. In the early stages of a lodgment, an AWACS may perform this function. In a mature theater, CRCs will be established, employing a network of highly mobile CRPs and forward air control points (FACPs) to accomplish their functions. Using organic radars, CRPs and FACPs feed an air picture to the CRCs. CRCs fuse the ground radar picture with data from aerial platforms (AWACS, E2C Hawkeye) and with intelligence information to produce a recognized air picture for their sector of operations. The ADA brigade FDC may coordinate directly with a CRC to effect this link.

Rear Area Operations Center

4-27. Rear area security is afforded through a combination of base cluster defenses, tactical combat forces, fire support, and command and control facilities. The RAOC coordinates rear battle operations within its AO. The RAOC has tasking authority over designated reaction forces and fire support. The RAOC establishes base clusters encompassing tenant units. It may also task brigade level headquarters in the corps or theater rear to organize ground defense plans within a base cluster. The ADA brigade coordinates with the RAOC for rear area security issues.

BATTLE COMMAND RELATIONSHIPS

4-28. The joint nature of AMD operations often produces complex command relationships. It is essential that air defenders understand both service and joint concepts of command and control. [Figure 4-3](#) summarizes the different joint command authorities.

<i>FUNCTION</i>	<i>COCOM</i>	<i>OPCON</i>	<i>TACON</i>

WHO AUTHORIZES:	(a) Title 10, USC, section 164 (b) SECDEF	Next higher HQ	Next higher HQ
WHO EXERCISES:	(a) Unified CINCs only (b) US CDR in a multinational command, when delegated by SECDEF	Any echelon below COCOM	Functional component CDRs over tasked forces
Can delegate	NO	√	√
Organize forces	√	√	NO
Assign tasks	√	√	
Designate objectives, establish boundaries	√	√	√
Approve subordinate plans	√	√	√
Support logistically	√	NO, unless specified	NO
Direct logistic or training preparations	√	Training: Yes ADMIN/LOG: No, unless authorized	NO
Employ forces	√	√	√
REMARKS:	Appropriate if forces are permanently assigned to the combatant commander	Inherent in COCOM Appropriate if forces are temporarily attached to a JFC	Inherent in OPCON

<p>Command exercised through subordinate</p>	<p>(a) services (b) functional components such as the LCC or ACC (c) JTF (d) single service force CDR (e) directly to designated units</p>	<p>(a) JFC (b) services</p>	<p>Directly over assigned forces</p>
<p>LIMITATIONS:</p>		<p>OPCON below the JFC level usually limited by time, function, or location</p>	<p>Limited by time, function, or location</p>

Figure 4-3. Joint Command Authorities

Support

4-29. The JFC may establish a support relationship by tasking one force to assist another force without actually subordinating the first force to the other. Joint doctrine establishes the support relationships of general support, mutual support, direct support, and close support.

- General support is the action that is given to the supported force as a whole rather than to a particular subdivision thereof.
- Mutual support is the action that units render each other because of their assigned tasks, their position relative to each other, and their inherent capabilities.
- Direct support is a mission requiring a force to support another specific force and authorizing it to answer directly the supported force's request for assistance.
- Close support is the action of the supporting force against targets or objectives that are sufficiently near the supported force as to require detailed integration or coordination of the supporting action with fire, movement, or other actions of the supported force.

COORDINATING AUTHORITY

4-30. Coordinating authority is exercised at any command echelon. It is delegated to a commander or individual for coordinating specific functions and activities involving forces

of two or more services, functional components, or two or more forces of the same service. The coordinating authority may require consultation between the agencies involved, but he does not have the authority to compel agreement. The corps ADA brigade commander, as the corps AMDCOORD has coordinating authority to synchronize all AMD operations within the corps AO. The AADC is the coordinating authority at the joint force level.

ADA COMMAND AND SUPPORT RELATIONSHIPS

4-31. Command relationships establish the degree of control and responsibility a commander has for forces operating under his control. Support relationships establish specific relationships and responsibilities between the supporting and supported units. The following paragraphs describe the types of command and support relationships that ADA units may find themselves operating under.

COMMAND RELATIONSHIPS

4-32. ADA units operate in some permanent command relationship to their higher headquarters. When units are an integral part of a higher echelon unit, as established by a table of organization and equipment (TOE), they are organic. A Patriot battery, for example, is organic to a Patriot battalion. If units are made a permanent part of a higher echelon unit by Department of the Army orders, they are assigned. A missile DS ordnance company, for example, may be assigned to an ADA brigade. Commanders exercise command over assigned and organic forces as normally organized and are responsible for their administrative and logistic support.

4-33. Commanders have the authority to organize their assigned and organic forces, as the situation requires. When forces are task organized, they may be OPCON to another unit or may be attached to it. Command relationships established by task organization are limited to the duration and purpose of the operation for which the task organization was directed. Commanders are not responsible to logistically support forces under OPCON, unless specified in the task organization order. Commanders have logistic responsibility for attached forces, unless specified otherwise in the task organization order.

ADA SUPPORT RELATIONSHIPS

4-34. Like joint support relationships, ADA support relationships provide AMD support to an element of the force without subordinating the AMD unit to that element under a command relationship. Army AMD doctrine outlines four support relationships: general support (GS), GS reinforcing (GSR), reinforcing (R), and direct support (DS). Divisional ADA units are usually task organized and employed as DS to a maneuver brigade or GS to the division. EAC ADA units may have a joint support role with the JFACC, or may be GS to an Army force. Synchronized corps and divisional AMD operations may involve all of

these support relationships. The following paragraphs describe AMD support relationships and some considerations in applying them.

General Support

4-35. A GS AMD unit provides air defense to the force as a whole and is not committed to any specific element of the force. ADA units usually operate under GS unless otherwise tasked. The support relationship is identified in the task organization order. This relationship is commonly used when the AMD unit protects corps elements in the division and corps rear areas. GS ADA units can rapidly respond to changes in either the scheme of maneuver or the air threat.

General Support Reinforcing

4-36. A GSR AMD unit primarily supports the force as a whole and secondarily augments the coverage of another AMD unit. GSR units are not committed to any specific element of the force. For example, this mission could be used where the corps commander desires to reinforce divisional AMD fires but retain close control over the additional unit. At corps level, corps priorities take precedence over division priorities for a GSR unit.

Reinforcing

4-37. A reinforcing AMD unit augments the coverage of another AMD unit. It also strengthens the air defense of the force as a whole. This mission differs from GSR in that the reinforced commander approves a positioning of a reinforcing AMD unit. Divisional priorities would take precedence over corps priorities for a corps AMD unit reinforcing a divisional unit.

Direct Support

4-38. A DS AMD unit provides dedicated air and missile defense for a specific element of the force. A DS AMD unit provides close and continuing support and coordinates its movement and positioning with the element it supports. A prerequisite for a DS relationship is that the supported force has no AMD capability of its own.

COMMAND AND SUPPORT RELATIONSHIPS APPLIED

4-39. In recommending AMD missions for the brigade and for divisional AMD to the corps commander, the corps AMDCOORD may also recommend the establishment of support or command relationships between ADA units. In task organizing his own forces, the ADA brigade commander may establish support or command relationships between subordinate units. An Avenger platoon, for example, could have a reinforcing support

relationship or an OPCON or attached command relationship with a HIMAD battalion. The commander must first decide whether AMD integration requires formal coordination. The commander must next decide whether to establish a command or a support relationship based on this formal coordination.

SPECIFIC AUTHORITIES AND RESPONSIBILITIES

4-40. [Figure 4-4](#) illustrates the specific authorities and responsibilities of AMD support relationships. Further information on support relationship can be found in [FM 6-99](#), Staff Organization and Operations.

ACTION	GS	GSR	R	DS
Mission	Parent Unit	Parent Unit	Parent Unit	Parent Unit
Who establishes AD priorities?	Parent Unit	1. Parent Unit 2. Reinforced Unit	1. Reinforced Unit 2. Parent Unit	Supported Unit
Who determines the unit location?	Parent Unit	Parent Unit	Reinforced Unit	Supported Unit
With who is commo and liaison established?	1. Parent Unit 2. As required by Parent Unit	1. As required by Parent Unit 2. Reinforced Unit	1. Reinforced Unit 2. Parent Unit	1. Supported Unit 2. Parent Unit
Who provides logistic support?	Parent Unit	Parent Unit	Parent Unit	Parent Unit

Figure 4-4. Support Relationships

BATTLE COMMAND, CONTROL, COMMUNICATIONS, COMPUTERS AND INTELLIGENCE

4-41. The battle command system must support the ability of the commander to adjust plans for future operations while focusing on the current fight. The battle command system for air and missile defense is grouped into two categories: EO and FO. EO and FO functions are closely related. There is a real-time interaction that takes place between many of the EO and FO functions during battle. This interaction results in continued force optimization as the battle progresses. The related tools for implementing command decisions include communications and computers.

BATTLE COMMAND CONCEPT

4-42. Battle command is the art of battle decision making, leading, and motivating soldiers as well as their organizations into action to accomplish missions at least cost to soldiers. Battle command includes visualizing the current and desired future states of friendly and enemy forces and then deciding how to get from one to the other at least cost. The commander assigns missions, prioritizes and allocates resources, selects the critical time and place to act, and knows how and when to make adjustments during the fight.

4-43. Commanders will assess; take risks; and see, hear, and understand the needs of subordinates and seniors. Commanders go where they can best influence the battle, where their moral and physical presence can be felt, and where their will to achieve victory can best be expressed, understood, and acted upon.

4-44. Battle command has two vital components: decision making and leadership. Both components demand skill, wisdom, experience, and courage. The two elements of battle command are tightly interwoven. They integrate leading, guiding, and motivating with the knowledge to establish and define the limits of control throughout the course of a mission.

Decision Making

4-45. Decision-making is knowing if to decide, then when and what to decide. Decision brings with it the cost of committing resources, foreclosing options, incurring risks, and revealing intentions to the enemy. Uncertainty and chance will always complicate decision-making.

4-46. Commanders cannot and should not attempt to know everything. However, commanders must know what is important. The battle command system must provide a solid base of information from which commanders can pick and choose what they need.

4-47. Commanders bear personal responsibility for defining the critical friendly or enemy information they need. Battle command demands that leaders position themselves where they can best command without limiting the ability to respond to changing situations.

Commanders must go where they can best assess the operation and risks and make the necessary adjustments.

4-48. Battle command demands that the commander retain objectivity when making decisions and not be swayed by the passions of the moment. Commanders cannot attempt to address personally every action. Knowing what requires their attention and what staff and subordinate commanders and leaders can handle is key to time management and a decentralized command environment.

Leadership

4-49. Leadership is taking responsibility for actions of the command and the decisions that caused those actions. Commanders will be compelled to act without all the relevant information and must be prepared to deal with the consequences thereof. After forces have been put into motion, the commander must provide the strength and will to follow through with his decisions. He must have the wisdom to recognize when changes have to be made.

4-50. The commander's strength of character and ability to motivate are among the most vital components of successful command. The commander serves as a role model. Commanders promote the proper ethical perspectives, sustain a positive and progressive command climate, and foster a sense of organizational unity and cohesion. Commanders are technically and tactically proficient. They possess the moral toughness that provides soldiers the will to fight.

COMMAND

4-51. Command and the decision making and problem solving that come with it are not done in isolation. The commander's staff and subordinates assist in developing, modifying, and improving the initial versions of plausible courses of action, and in the development of future courses of action.

4-52. Battle commanders must be flexible enough to respond to changing situations and anticipate the demands of future operations and the solutions to them. They must train themselves, their staffs, soldiers, and units so that they are prepared for whatever missions they may be assigned. Commanders must be able to visualize the future, formulate concepts, allocate means, and direct the necessary missions required to achieve victory.

Estimation

4-53. Commanders make assessments of the current situation and estimates of future operations to determine their own intent and formulate the concept of operation. Commanders determine the amount of delegation to others by prioritizing actions and the

acceptable degree of risk. This delegation synchronizes actions across the area of operation. Command without freedom of action to subordinates denies their initiative and lessens the ability of the battle commander to employ all resources to their fullest potential.

Tempo Requirements

4-54. Tempo requires both mental and physical agility by leaders and organizations. Commanders must possess the mental agility and discipline to make timely decisions to modify the tempo to their advantage, deny the enemy the initiative, and decisively defeat him at the selected place and time.

CONTROL

4-55. Control is inherent in battle command. Control is more scientific than command. Control monitors the status of organizational activities, identifies deviations from the commander's intent, and regulates the forces and means toward an intended aim.

4-56. Control provides the commander freedom to operate, delegate authority, and lead from any position on the battlefield while synchronizing actions vertically and horizontally throughout the AO. Control derives from understanding the commander's intent, training units and soldiers, rehearsing, and maintaining continual dialogue among commanders at all levels. Proper control ensures all operations are synchronized and sustained throughout their duration. The process is directed towards ensuring that the efforts of all elements are synchronized and adjusted as the situation dictates. Additionally, it maintains the focus on the intended end state and purpose expressed in the commander's intent. Skilled staffs work within the commander's intent to direct and control units and allocate the means to support the intent.

4-57. The role of the staff is defined and focused by the commander. The staff and subordinates assist the commander in developing, modifying, and improving the initial versions of courses of action. They perform the intelligence gathering and planning. It is through the staff and battle command systems that the commander exercises control. Staffs compute requirements, allocate means, and integrate efforts. They monitor the status of organizations, identify variance, correct deviations, and push analyzed information to the commander. Staffs acquire and apply means to carry out the commander's intent and develop specific instructions from general guidance.

COMMAND AND CONTROL STRUCTURE FOR ADA BRIGADES

4-58. The EAC brigade is under the command of the AAMDC and OPCON to the land component commander (LCC). Corps ADA brigades are under the command and control of the supported corps commander. Both EAC and corps ADA brigades follow the weapon

control procedures and measures established by the AADC for conducting theater air and missile defense. [Figure 4-5](#) shows the command and control structure for ADA brigades in a mature theater.

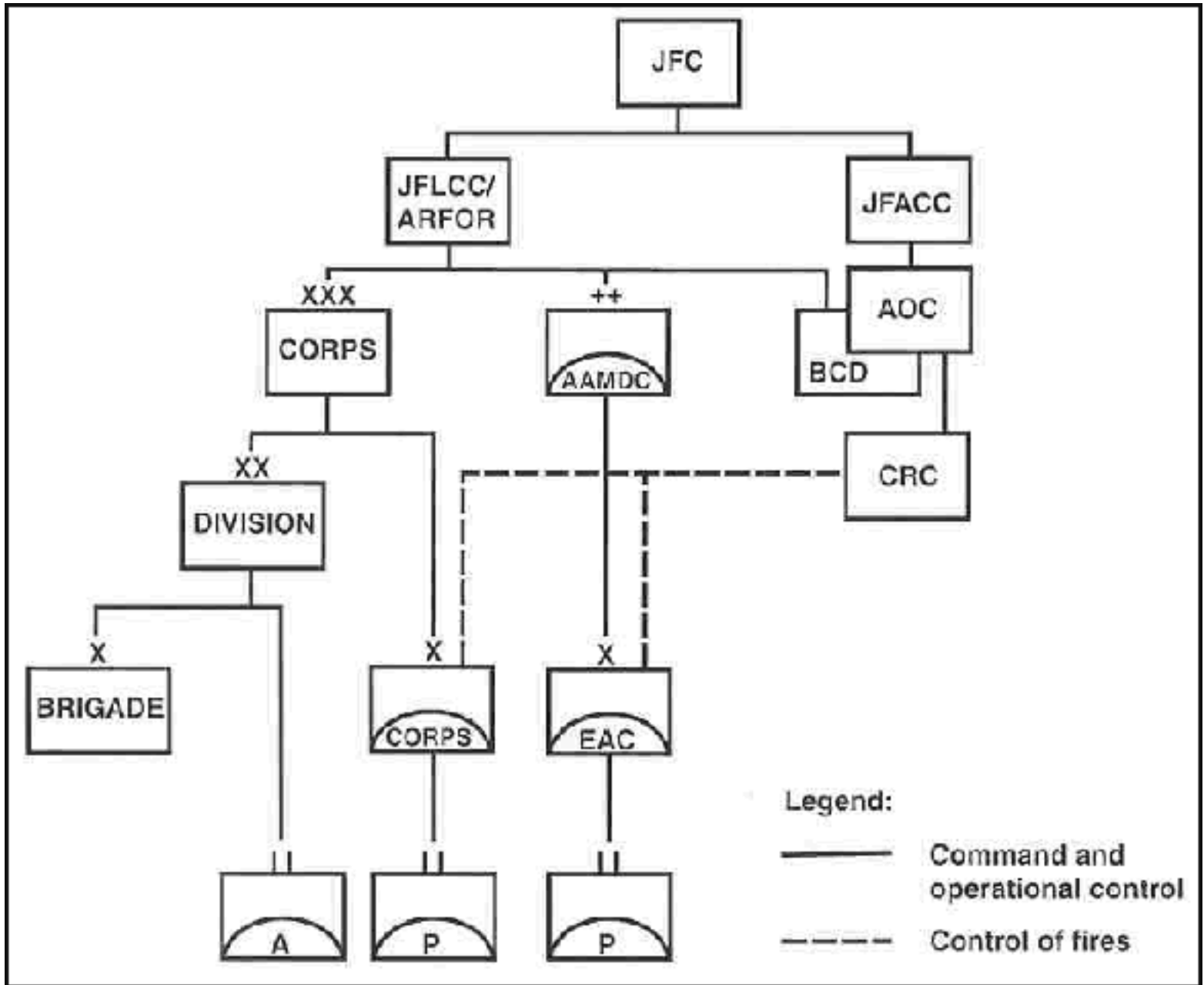

Figure 4-5. Command and Control Relationships

CONTROL CHAIN

4-59. The control chain is a more complex structure than the command structure. In a US environment, the theater commander assigns responsibility for overall air defense and airspace control to a single commander. This may be any commander, but is usually the Air Force component commander (AFCC) who is both the AADC and the airspace control authority (ACA). The AADC manages by coordinating and integrating the entire counterair

and active defense effort within the theater. The AADC may create air defense regions and appoint a commander for each.

4-60. The region air defense commanders (RADC) may be selected from any service component. The RADC is fully responsible for and has full authority for the air defense of the region. The CRC supervises the surveillance and control activated of subordinate radar elements, provides means for air traffic identification, and directs region air defense. The CRC exercises engagement control over both the EAC and corps ADA brigades. The AAMDC exercises operational control less engagement control over the EAC ADA brigade while the corps commander exercises OPCON less engagement control over the corps ADA brigade.

COMMUNICATIONS

4-61. The battle command style of the commander shapes the structure of the supporting communications system. The commander is able to move freely about the battlefield and is electronically linked with the command post to access time-sensitive data and to influence the battle. Reliable communications are imperative to battle command and to control. Effective battle command requires reliable signal support systems to enable the commander to conduct operations at varying tempos over extended distances. Good signal planning increases the commander's options to exploit success and facilitate future operations.

4-62. Space-based systems provide commanders with intelligence, reconnaissance, surveillance, navigation, and early warning and positioning information that facilitate battle command. Satellite communications support all AMD task forces. These space-based systems significantly upgrade the speed and accuracy of information that commanders exchange.

4-63. Tactical information must be communicated among commanders, staffs, and weapons systems. The commander must be able to communicate his intent while moving freely about the battlefield. Electronically linked with the command post, the commander must be able to access time sensitive operational and intelligence information to assess and influence the battle at the critical time and place. A seamless, secure communications network that provides horizontal and vertical integration of voice, data, graphics, imagery and video information is essential. This network supports integrated combat operations and focuses on the warfighting commander.

AIRSPACE COMMAND AND CONTROL

4-64. The modern battlefield, including the airspace above it, is becoming increasingly saturated. Executing the airspace control function requires a joint effort by using service

airspace C² systems as a framework for integration.

AIRSPACE CONTROL AUTHORITY

4-65. The ACA develops a joint airspace control plan that establishes coordination and identification procedures, and responsibilities of airspace controllers. It segments the airspace for various airspace users. The ACA promulgates a daily airspace control plan in conjunction with the JFACC ATO planning cycle. The LCC is normally delegated airspace management authority below an established coordinating altitude. The corps may publish its own ACO for Army aviation operations below the coordinating altitude. AMD involvement in airspace control stems from the fact that AMD weapons control procedures are directly affected by airspace control measures. The ADA Brigade coordinates planning with the force Army airspace command and control (A²C²) element to influence the development of an airspace plan that meets JFC objectives and does not unduly constrain ADA operations. CRCs and corps ATC elements positively manage friendly air traffic control above and below the coordinating altitude respectively.

AIRSPACE CONTROL ORDER

4-66. Army headquarters can obtain the ACO from Air Force liaison elements such as the corps air support operations center (ASOC) or from Army liaison elements located in Air Force headquarters such as the BCE. Current automation capabilities permit the ACO to be distributed on computer disk or electronically by various means. The CADE and AAMDC coordinate directly with the A²C² element and pass the current ACO and any corps ACMs to the brigade. If possible, this coordination is done electronically. The ADA brigade provides all relevant measures to subordinate SHORAD and HIMAD battalions. AMD battalions ensure that all AMD firing units are in possession of current ACO information. The Patriot battalion may pass the ACO electronically to subordinate fire units by using established data links. ACMs are checked at every echelon for accuracy before implementation.

AMD AIRSPACE

4-67. Joint doctrine outlines numerous means for allocating or reserving airspace for various military purposes. AMD ROE vary with each measure. [FM 3-100.1](#) describes the principal airspace control means, but combatant commanders and joint force commanders may implement other measures based on theater requirements. Because AMD operations occur within the air environment, they must be synchronized with air operations by airspace control means as well as by positive control. ADA units may require special airspace control volumes to accomplish their missions. The following paragraphs describe some airspace control means used by ADA units.

Missile Engagement Zone

4-68. A missile engagement zone (MEZ) is a weapons engagement zone (WEZ) for HIMAD operations. It is a defined volume of airspace where a specific type of AD weapon is preferred for use in an engagement of high priority targets. A MEZ is activated through the STO, which is promulgated by the AADC or the DAADC.

Weapon Engagement Zone

4-69. The AADC uses WEZs to segment the air defense battle space as a fire distribution tool. DCA fighters have primary responsibility for air defense within fighter engagement zones, while HIMAD units have priority within a MEZ. For the ADA brigade, the MEZ represents the AADC's establishment of the HIMAD area of operations in the third dimension of the battlefield. HIMAD units cannot engage outside a MEZ unless ordered or in self-defense. Finally, the MEZ serves as a 'NOTAMS' warning to aircraft that SAM engagement operations are ongoing.

4-70. For EAC ADA units OPCON to the AADC, the MEZ may be allocated in conjunction with an area defense mission order. For corps ADA units, the MEZ is not a mission but an AO. It continuously adjusts to encompass mobile corps AMD defenses. The AMDCOORD coordinates through AMD channels to plan a phased sequence of MEZs, normally coinciding with the corps boundaries and the forward/rear limits of HIMAD coverage. The BCE ensures that MEZ requirements get incorporated into the ACO.

Weapons Free Zone

4-71. A weapons free zone (WFZ) is a volume of airspace where the governing weapons control status is WEAPONS FREE. WEAPONS FREE can apply generally or can apply to a specific air platform. WEAPONS FREE could also be specified as applicable only to HIMAD, though it is more relevant to SHORAD systems. ADA commanders often desire a weapons free zone because it simplifies the target identification problem and speeds the engagement process. Fratricide is a major consideration, however, in determining the advisability of a weapons free zone. The force commander and his AMDCOORD must weigh the risks of losing close air support in the designated area against the risks associated with enemy air attacks. If the commander is relying mainly on his own air maneuver assets for aerial fire support, then a weapons free zone for fixed wing aircraft may be feasible. If the enemy can achieve air superiority over the force, then a WFZ over a critical asset may be advisable.

JOINT BATTLE SYNCHRONIZATION

4-72. Control is inherent in command. To control is to regulate forces and functions to

execute the commander's intent. The commander establishes positive controls and procedural controls to regulate the execution of the operation. Together with a clearly stated commander's intent, effective controls are vital for decentralized execution of operations. A mix of positive and procedural controls governs ADA units. Patriot air battle operations are positively controlled by engagement orders passed through voice and data links from battalion, brigade, and AADC fire control facilities. A team chief/squad leader visually identifying an aircraft, positively controls SHORAD engagements. Procedural controls include rules of engagement (ROE), airspace control orders, hostile criteria, and weapons control status, SAM tactical orders, and other more general orders. The AADC is the joint force authority for promulgating positive and procedural control measures.

POSITIVE CONTROL

4-73. Positive controls provide a means to put "eyes" on a target, to order engagement by a specific fire unit, and to monitor the engagement. Positive control minimizes the risk of fratricide and is a basic requirement for SHORAD as well as HIMAD engagement operations. Positive control also serves to distribute or mass AMD fires. It facilitates mutual support between fire units during an air battle. Positive controls are important for both force and engagement operations. AMD commanders are the primary authority for positive control. Liaison officers extend this control by representing him in an adjacent C² headquarters.

Recognized Air Picture

4-74. HIMAD positive control is enabled by a recognized air picture (RAP) that synthesizes data from multi-service intelligence and air defense sensors, correlates air tracks, and identifies them based on an integrated airspace control plan and established hostile criteria. The AADC is responsible for producing the RAP for the joint force and for specifying the level of control. The ADA brigade FDC receives and distributes the RAP. The RAP is provided to subordinate HIMAD fire units over TADIL-J. With FAAD C³I, the RAP can also be distributed to subordinate SHORAD battalions for early warning.

Control of Engagements

4-75. Control of engagements is effected by a network of C² centers. The AADC identifies how HIMAD engagements will be generally controlled by specifying the mode of control and the level of control. The mode of control prescribes the AD echelon at which positive management of the air battle is being conducted. This can be an AOC, CRC, ADA brigade FDC, battalion FDC, or an individual fire unit. The level of control identifies the engagement authority or the element authorized to order the engagement of an air target. There are two modes of positive control for HIMAD operations. Centralized control is used when fratricide is a paramount concern. Fire units will only engage an air target when

ordered by the engagement authority. Decentralized control is used when attrition of the enemy is the main concern. Fire units may engage enemy targets at will during decentralized control. In decentralized corps AMD operations, the battalion and brigade FDCs monitor the air battle and intervene to prevent target engagement by more than one fire unit or to ensure proper fire distribution.

FIRE CONTROL COMMANDS

4-76. Standard fire control commands are established in [FM 3-01](#) for AMD engagements. ADA fire units that lose automated fire control link or voice communications to an engagement authority cannot be positively controlled. They are subject to procedural controls and continue to conduct operations in an autonomous operations mode of control. Unlike an EAC ADA brigade, which may be conducting AMD engagement operations under the control of the AADC, the corps ADA brigade missions normally involve force protection of a maneuvering corps. CRC may distribute fires and order engagements by an OPCON EAC ADA brigade unit but it may only veto engagement orders issued by the corps ADA brigade FDC based on intelligence or other factors.

PROCEDURAL CONTROLS

4-77. Procedural controls supplement positive controls and compensate for a lack of adequate C⁴I capability. SHORAD battalions typically do not distribute the RAP to fire unit level and do not positively control engagement operations above fire unit. C⁴I outages can make HIMAD engagement operations dependent on procedural controls. Procedural controls include orders, reporting requirements, coordinating instructions, and SOPs.

Airspace Control

4-78. Control of airspace is a force protection function, centrally directed at the joint force level by an appointed Airspace Control Authority (ACA). Efficient use of airspace maximizes friendly air maneuverability and facilitates AMD identification and engagement operations.

Rules of Engagement

4-79. Engagement operations are controlled procedurally by established rules of engagement (ROE). ROE are promulgated at the joint force level. They establish criteria for engaging a target. The AMDCOORD recommends appropriate ROE for the operation.

Weapons Control Status

4-80. Although applicable to all AMD systems, weapons control statuses (WCS) are

procedural controls used mainly for SHORAD weapons engagements. They function similar to HIMAD modes of control. For example, WEAPONS FREE allows fire units to engage both hostile and unknown targets. It is useful in maximizing attrition in large air attacks. WEAPONS TIGHT allows fire units to engage only positively identified hostile targets and serves to minimize fratricide. WEAPONS HOLD prohibits all engagements except as specifically ordered or in self defense. This is useful in situations where other military or political considerations outweigh the benefits of engaging even a confirmed hostile target. WCSs can apply generally or can be specified for particular AMD weapons, aerial platforms, or for specific volumes of airspace. The ADA brigade CP ensures that all ADA fire units are in receipt of the current weapons control status.

BATTLE READINESS MANAGEMENT

4-81. All ADA fire units cannot be battle ready all the time. Commanders must manage force readiness so that fire unit maintenance, repositioning, and crew rest requirements are met, while sustaining an overall force posture consistent with the threat. The ADA brigade may use any or all of the tools outlined below to accomplish this.

Weapons Alert Designators

4-82. Weapons alert designators (WAD) provide commanders guidance on the percent of fire units that must be at various states of readiness (SOR). These SORs may be defined in terms of readiness to fire or readiness to move and specific criteria for each should be established in the brigade tactical SOP. WAD are equally applicable to SHORAD and HIMAD units, though the SORs may differ. The corps SHORAD battalion, for example, may use a WAD system to provide guidance to platoon leaders on how many fire units must be battle ready for specific platoon missions. WADs are promulgated in the brigade OPOD and managed by battalion commanders. [Figures 4-6](#) and [4-7](#) outline a sample WAD system.

WAD	RTF	30 min.	1 hr	3 hr	12 hr	RTM
A	ALL					
B	60%	20%	20%			
C	40%	20%		20%	20%	
D	30%	20%			50%	
E	30%	20%		20% ^o		30%
F	60%				20%	20%
G	50%	20%			30%	
H	30%	20%				50%

NOTE: X%= % of fire units; RTF = Ready to Fire; RTM = Ready to Move w/in 10 min.

Figure 4-6. HIMAD Weapons Alert Designators

WAD	RTF	30 min.	1 hr	3 hr	12 hr
A	ALL				
B	80%	10%	10%		
C	60%	10%	20%	10%	
D	40%	20%		20%	20%
E	30%				70%

NOTE: X% = % of fire units at each readiness condition

Figure 4-7. SHORAD Weapons Alert Designators

Air Defense Warnings

4-83. Irrespective of overall force readiness, air defense warnings (ADW) establish the commander's estimate of the probability of near term air attack. The AADC establishes the baseline ADW for the joint force. Subordinate air defense commanders may issue a higher but not lower ADW for their AO. ADWs are disseminated to all AMD elements and fire units. The CADE is responsible for issuing or retransmitting the ADW from the corps CP.

MULTINATIONAL OPERATIONS

4-84. Large scale US military operations will often be multi-national operations, conducted with the military forces of other nations toward a common purpose. Existing multinational structures are evolving toward multinational integration at lower levels. Within US Army Europe, for example, the V (US) Corps is organized in peacetime with assigned US and German divisions. ADA units might similarly receive missions putting them in support of or under the operational command of an allied headquarters. The ADA Brigade will be required to integrate with adjacent allied ADA headquarters into a multinational C² structure. A combined joint force may be organized around an existing military framework like NATO or may be ad hoc and temporary. A corps JTF might also be a combined JTF. An important task in combined AMD operations is to minimize the impact of differences in language, national doctrine, training, organization, and equipment on the combined force operation. This can be done through effective liaison, well-coordinated planning, and clearly articulated joint force goals and intent.

ENGAGEMENT OPERATIONS PRINCIPLES

4-85. Effective battle command enables active defense forces to successfully perform their combat missions and support overall force objectives. The following fundamental principles form the basis for active defense engagement operations.

- Centralized planning with decentralized control

- Air battle management
- Management by exception

4-86. Although these principles apply to both air and missile defense activities, they particularly relate to the management of missile defense operations.

CENTRALIZED CONTROL WITH DECENTRALIZED EXECUTION

4-87. Centralized control permits the full exploitation of the combat effectiveness of AMD operations at each level of command. Centralized control ensures unity of effort. Decentralized execution provides subordinate commanders the flexibility to achieve the tenet of agility.

Centralized Control

4-88. Centralized control is essential to ensure integration and coordination of all AMD assets from the AADC down to the AMD fire unit. Centralized control also facilitates the synchronization of offensive and defensive operations within the Army and among participants in joint or multinational operations. In the case of corps and divisional ADA, centralized control is executed through compliance with the theater ROE and air defense weapon control procedures. Data integration and operational coordination complete the synchronization.

Decentralized Execution

4-89. Decentralized execution is necessary because of the number of activities associated with air defense operations. One commander cannot effectively control all air defense forces and actions. Decentralized execution also enables air defense assets to maximize their individual capabilities and meet the extreme engagement time lines of air and missile threats. Thorough planning and coordination link centralized control and decentralized execution.

AIR BATTLE MANAGEMENT

4-90. The related functions of airspace control and active defense engagement operations are coordinated through the principle of air battle management that maximizes both offensive and defensive effectiveness. Air battle management is essential in an air environment that has large quantities of both threat and friendly air users. Current weapon systems, although highly sophisticated, do not possess infallible identification technology. Therefore, the goal of air battle management is to control the engagement of air targets, ensuring the destruction of enemy air targets while preventing fratricide and unnecessary multiple engagements.

4-91. Extensive coordination is necessary to prevent interference among all airspace users. As a participant in air battle management, the AMDCOORD at each level of command ensures close coordination among all airspace users. Management of the air battle employs a mix of positive and procedural control measures.

Positive Control Measures

4-92. Positive control relies upon real-time data from sensors, IFF, computers, digital data links, and communications equipment to provide airspace and missile defense control. Positive control is desirable but not always possible due to battlefield conditions and inherent system vulnerabilities. Facilities for positive control are subject to direct attack, sabotage, or jamming. Line-of-sight requirements and limited communications assets can also restrict the availability of data from facilities that are operational.

Procedural Control Measures

4-93. Procedural control overcomes positive control and identification shortcomings. Procedural control relies upon techniques such as segmenting airspace by volume and time and using WCS. Procedural techniques are usually more restrictive than positive control techniques but are less vulnerable to degradation from electronic or physical attack. Procedural control enhances the continuity of operations under the adverse conditions on the battlefield. For example, it provides an immediate backup system should degradation of positive control occur. Additionally, procedural techniques provide a management means for missile defense systems that do not have real-time data transmission or receipt capabilities.

Mix of Positive and Procedural Control

4-94. The optimum method of controlling active defense operations is a mix of positive and procedural techniques. Commanders charged with air battle management consider the factors of METT-TC in their analysis and specifically focus on mission, AO, and the threat expected.

4-95. For positive management, commanders also consider the numbers and types of electronic means available. This will vary according to the depth of the battlefield. As operations move farther forward, available means for positive control decrease, necessitating additional procedural management.

4-96. The nature of the theater may also dictate what type of control is used. Mature theaters have elaborate and tested electronic management facilities. Contingency theaters may have no such systems and will rely more heavily on procedural control. As the

lodgment area expands and additional assets arrive in theater, a transition to more positive control may take place.

MANAGEMENT BY EXCEPTION

4-97. The principle of management by exception indicates the difficulty of one commander directing the overall air battle on a real-time basis. The AADC must supplement positive control with procedural techniques to ensure coordination and provide unified direction to the battle. Tactical situations may arise that procedural or positive control rules and directives do not address. In these instances, management by exception would take place to ensure proper fire distribution, to prevent engagement of friendly air platform, or to prevent simultaneous engagements of hostile air targets.

ENGAGEMENT OPERATIONS PROCEDURES

4-98. Engagement operations procedures facilitate the integration of missile defense into both the force commander's concept of operation and the battle for air superiority. The AADC establishes and promulgates JFC approved ROE for air and missile defense. Additionally, the AADC in conjunction with the ACA and component commanders may establish airspace coordination areas such as fighter and missile engagement zones. The principal army users of the procedures are ADA units, but all participants in air and missile defense operations must adhere to these procedures.

WARNING PROCEDURES AND ALERT STATUSES

4-99. Warning procedures and alert status prepare or cause units to build up for combat. Most warning procedures and alert statuses have specific applications for air defense forces.

DEFENSE READINESS CONDITIONS

4-100. Defense readiness conditions (DEFCON) describe progressive alert postures primarily for use between the JCS and the commanders of unified commands. DEFCONs are graduated to match situations of varying military severity and are numbered from one to five as appropriate. DEFCONs are most applicable to national missile defense.

WEAPONS ALERT DESIGNATORS SYSTEM

4-101. WADs describe a progressive system of alert postures. The AMD commander specifies minimum percentages of ADA fire units within the parent organization, which are required to be at a given state of readiness. AMD commanders use WADs to meet the threat, provide readiness, and allow crew rest among other tactical concerns.

STATES OF READINESS

4-102. States of readiness (SOR) describe the degree of readiness of ADA fire units and sensors expressed in minutes from time of alert notification to time of weapon firing or sensor in operation. SOR are based on the WAD and ADW. SOR for SHORAD units may be designated down to the platoon level. SOR can specify personnel manning requirements. SOR can be modified to include emission control and system configuration considerations. These are called states of emission control (SOE). ADA commanders use WAD and SOR to ready the force in a logical way for action against the enemy while retaining the ability for units to rest or perform maintenance.

STATES OF EMISSION

4-103. States of emission (SOE) prescribes the number and type of emitters or transmitters in operation. SOEs are initiated during combat operations. All electronic emissions must be carefully controlled. Emission control (EMCON) begins with passive techniques to prevent detection by the enemy. SOEs may have different characteristics based on systems or commands or both. SOEs are designated by the AADC and tied to each theater.

ADW DEFINITIONS

4-104. ADWs represent the commander's evaluation of the probability of air attack within the AO. Area or region air defense commanders routinely issue ADWs. Any commander can also issue them. However, the local ADW can be no lower than the overall ADW issued by the air defense area or region commander. The issuance of an ADW is not tied to any other warning procedure or alert status. A commander may issue an ADW regardless of DEFCON or WAD. However, ADWs can be used by a commander to influence the readiness posture of ADA units by raising or lowering the WAD or SOR. The three ADWs are discussed in the following paragraphs.

ADW Red

4-105. ADW Red warns that an attack by hostile aircraft or missiles is imminent or in progress. This means that hostile aircraft or missiles are within a respective AO, or are in the immediate vicinity of a respective AO with a high probability of entry thereto.

ADW Yellow

4-106. ADW YELLOW warns that an attack by hostile aircraft or missiles is probable. This means that hostile aircraft or missiles are enroute toward a respective AO, or unknown aircraft or missiles suspected to be hostile are enroute towards, or are within, a

respective AO.

ADW White

4-107. ADW WHITE warns that an attack by hostile aircraft or missiles is improbable. ADW white can be declared before or after ADW yellow or red.

AIR DEFENSE EMERGENCY

4-108. Air defense emergency (ADE) is an emergency condition declared by the Commander in Chief, North American Aerospace Defense Command. ADE is declared when an attack upon the continental United States, Canada, or US installations in Greenland by hostile aircraft or missiles is considered probable, imminent, or taking place. ADE can be declared worldwide when the SSTO generated by AFCENT or AAMDC directs a unit to ADE.

RULES OF ENGAGEMENT DIRECTIVES

4-109. ROE are positive and procedural directives that specify the circumstances and limitations under which forces will initiate or continue combat engagements with enemy forces. The JFC approves the theater ROE. These established ROE enable the AADC to delegate the authority to execute air defense operations. The ROE also permit the AADC to retain control of the air battle by prescribing the exact conditions under which engagements may take place. ROE are a direct reflection of the centralized control with decentralized execution principles of air defense. ROE apply to all warfare participants in the theater and are disseminated to all echelons of air, land, and sea forces.

RIGHT OF SELF DEFENSE

4-110. Commanders have the responsibility to take whatever action is necessary to protect their forces and equipment against air or missile attack. When under attack, the right of self-defense takes precedence over any other established rules and procedures that normally govern engagements.

HOSTILE CRITERIA

4-111. Hostile criteria are basic rules that assist in the identification of friendly or hostile air platforms. These rules are promulgated by the commanders of unified commands and other appropriate commanders when authorized. The commander who establishes hostile criteria parameters may consider the factors of speed, altitude, heading, or other requirements within specified volumes of airspace. The commander also considers specific enemy characteristics or hostile acts. Echelons having identification authority use hostile

criteria to determine the identification of detected air targets. The highest echelon capable of managing engagement operations normally retains identification authority. Fire units with real-time data transmission capability assist the controlling authority by forwarding target information. The controlling authority makes final target identification and delegates engagement authority. Delegation of the controlling and identification authority to lower echelons is normal for ADA and non-ADA units that do not have real-time transmission capability for identification data. Such units have both identification and engagement authority. Because TMs are uniquely classified and identified separately, TMs launched from hostile territory are considered hostile immediately upon detection.

WCS DEFINITIONS

4-112. WCS describes the relative degree of control of air defense fires. WCS applies to weapons systems, volumes of airspace, or types of air platforms. The degree or extent of control varies depending on the tactical situation. Establishment of separate WCS for fixed and rotary-wing aircraft and for missiles is normal. Air defense forces must have the ability to receive and disseminate WCS for all classes of air platforms. The AADC imposes the fixed-wing WCS. The AADC normally delegates the authority for establishing rotary-wing WCS to the appropriate maneuver force commander. The AADC may also delegate WCS for UAVs to the maneuver force commander. The maneuver force commander may further delegate the authority to subordinate maneuver commanders based on the tactical situation or operation. Maneuver commanders who do not have authority to establish WCS still may direct a more restrictive WCS in their AO. The following paragraphs define WCSs.

Weapons Free

4-113. Weapons can fire at any air target not positively identified as friendly. This is the least restrictive WCS.

Weapons Tight

4-114. Weapons can fire only at air targets positively identified as hostile according to the prevailing hostile criteria. Positive identification can be effected by a number of means to include visual ID (aided or unaided) and meeting other designated hostile criteria supported by track correlation.

Weapons Hold

4-115. Weapons do not fire except in self-defense or in response to a formal order. This is the most restrictive WCS.

LEVEL OF CONTROL

4-116. Describes the AD echelon at which positive management of the air battle is being conducted. This can be an AOC, CRC, ADA brigade FDC, ADA battalion FDC, or the individual fire unit. For missile defense operations, engagement control is delegated to the fire unit level.

MODES OF CONTROL

4-117. The two modes of control are centralized and decentralized. The mode of control selected will depend upon the capabilities of the C⁴I system, the weapons systems being employed, and both the friendly and enemy air situation.

Centralized Control Definition

4-118. Centralized control is where a higher echelon commander dictates target engagements to fire units. Permission to engage each track must be requested by the fire unit from that higher AD echelon. Centralized control is used to minimize the likelihood of engaging friendly aircraft, while permitting engagements of hostile aircraft only when specific orders are issued to initiate the engagement.

Decentralized Control Definition

4-119. Decentralized control is the normal wartime mode of control for AMD, whereby a higher echelon monitors unit action, making direct target assignments to units only when necessary to ensure proper fire distribution, to prevent engagements of friendly aircraft, and to prevent simultaneous engagements of hostile aircraft. Decentralized control is used to increase the likelihood that a hostile aircraft or missile will be engaged as soon as it comes within range of an AMD weapons system. Control of engagement operations during the air battle can be centralized at a higher headquarters FDC, or decentralized to a subordinate FDC. For instance, in a situation where battle management has been decentralized down to the battalion FDC, the battalion commander exercises control of the engagement operations. At the same time, the brigade FDC is continuously monitoring the actions of the battalion FDC. The brigade FDC is exercising decentralized control, while the battalion FDC is exercising centralized control. Thus, centralized control and decentralized control are conducted simultaneously at different echelons.

Autonomous Operation

4-120. An autonomous operation is the mode of operation assumed by a unit after it has lost all communications with higher echelons. The unit commander assumes responsibility for control of weapons and engagement of hostile targets. Rules of engagement in effect at the time of loss of communications remain in effect unless prescribed or ordered otherwise.

FIRE CONTROL ORDERS

4-121. Fire control orders are used to control engagements on a case-by-case basis regardless of the prevailing WCS. Higher control echelons, when monitoring the decentralized operations of subordinate units, most often use these commands. Fire control orders can be transmitted electronically or verbally. The following paragraphs describe fire control orders.

Engage

4-122. Command used to order a unit to fire on a specific target. This order cancels any previous fire control order given that target.

Cease Engagement

4-123. Command used to stop tactical action against a specified target. This command is always followed by an engage command. It is used to change an ongoing engagement of one target to another of higher priority. Missiles in flight are allowed to continue to intercept.

Hold Fire

4-124. Emergency fire control order used to stop firing and all tactical action. Missiles in flight are destroyed. This order is used to protect friendly air.

Cease Fire

4-125. Command given to ADA units to refrain from firing on, but to continue to track an airborne object. Missiles in flight are allowed to continue to intercept. This command is used to prevent simultaneous target engagements by manned fighters and ADA units.

Cover

4-126. Command used to order a fire unit to a posture that allows engagement of a target if directed. For radar directed systems, this means achieving a radar lock on the target. This order can be used for targets that are being engaged by another fire unit or for targets that may become a significant threat. Units receiving this command report tracking, lock on, and ready to fire statuses. This command does not apply to Patriot.

Engage Hold

4-127. This command applies to Patriot units. It is used to restrain a fire unit from automatically engaging a target. If the fire unit has not fired, target tracking continues. Missiles in flight are allowed to continue to intercept.

Stop Fire

4-128. An emergency fire control order to temporarily halt the engagement sequence due to internally unsafe fire unit conditions. It is seldom transmitted outside the fire unit. This command can be given by anyone in the fire unit who detects an unsafe condition. The engagement continues after the unsafe condition has been corrected.

SUPPLEMENTAL FIRE CONTROL MEASURES

4-129. Supplemental fire control measures are procedural control measures which delineate or modify hostile criteria, delegate identification authority, or serve as aids in fire distribution or airspace control. Army commanders request the establishment of supplemental fire control measures through the A²C² system. The approval authority is normally the ACA located in the AOC. The following paragraphs describe supplemental fire control measures.

AIR DEFENSE OPERATIONS AREA

4-130. Air Defense Operations Area (ADOA) is an area and the airspace above it where procedures are established to minimize mutual interference between air defense and other operations. The following paragraphs describe the different ADOA designations.

Air Defense Action Area

4-131. This is an area and the airspace above it where friendly aircraft or AMD weapons are normally given precedence in operations except under specified conditions. This type of ADOA is primarily used to minimize mutual interference between friendly aircraft and AMD weapons systems. ADOA which have been prioritized for AMD weapons are similar to restricted operations areas for aircraft, except that ADOAs are normally in effect for longer periods of time.

Air Defense Area

4-132. Air defense area is the specifically defined airspace for which air defense must be planned and provided. This type of ADOA is primarily used for airspace control, but may also be used to define any area within which ADA units are operating.

Air Defense Identification Zone

4-133. Air defense identification zone (ADIZ) is the airspace of defined dimensions within which the ready identification, location, and control of airborne vehicles are required. This type of area is normally used only for airspace control. Extremely stringent hostile criteria and WCS will normally characterize areas within an ADIZ.

Weapon Engagement Zone

4-134. WEZ identifies a volume of defined airspace within which a specific type of AD weapon is preferred for use in an engagement. Use of WEZ does not preclude engagement of high-priority targets by more than one type of weapon system if centralized control of each weapons system involved is available. The activation of a WEZ can be used to delegate identification and engagement authority. The WEZ can be used for specific threats. For example, a manned aircraft WEZ can be established for fighters while AMD would still be able to engage missiles and UAVs. Commonly used WEZs include the following:

- **Fighter Engagement Zone (FEZ):** FEZ is established in an area where no effective surface-to-air capability is employed.
- **Missile Engagement Zone (MEZ):** MEZ is a volume of airspace that establishes control over engagements by HIMAD. A MEZ defines the volume of airspace within which these weapons can conduct engagements without specific direction from the authority establishing the WEZ.
- **Short Range Air Defense Engagement Zone (SHORADEZ):** SHORADEZ is an area of SHORAD deployment that may fall within a MEZ. Also, SHORAD assets may solely defend some areas. A SHORADEZ can be established to define the airspace within which these assets will operate. Because centralized control over short-range air defense weapons may not be possible, these areas must be clearly defined and promulgated so that friendly air can avoid them.
- **Joint Engagement Zone (JEZ):** JEZ is a concept under study. In a JEZ, AD forces from two or more components (one airborne and one surface based) operate together in the same volume of airspace. If the targets meet specified hostile criteria, the controlling authority can conduct AMD engagements within an activated WEZ. This holds true regardless of the level of control, weapons control status, or hostile criteria in effect outside of the activated WEZ. Thus, an activated WEZ supplements AMD hostile criteria and is used by FDCs and fire units to make target assignments and engagement decisions.

High-Density Airspace Control Zone

4-135. High-density airspace control zone (HIDACZ) is airspace of defined dimensions in which there is a concentrated employment of numerous and varied airspace users. These

can include aircraft, artillery, mortar, naval gunfire, local AD weapons, UAVs, and SAMs. The airspace control authority, upon request of ground commanders, establishes HIDACZs. HIDACZ is established when the level and intensity of airspace operations dictate the need for special airspace control measures. The number of such zones will vary depending on the combat situation and the complexities of airspace control in conjunction with fire support coordination. The establishment of a HIDACZ normally will increase temporary airspace restrictions within the volume of defined airspace. Additionally, establishment of a HIDACZ within a maneuver area will normally give that maneuver commander complete weapons control status authority within the activated HIDACZ.

Weapons Free Zones

4-136. Weapons free zones are air defense zones established for the protection of key assets. Units are at weapons free within this zone.

Temporary Airspace Restrictions

4-137. Temporary airspace restrictions can be imposed on segments of airspace of defined dimensions in response to specific situations and requirements. These include combat air patrol operations, air-refueling areas, and concentrated interdiction areas. Restrictions include the following measures:

- Identification of the airspace user being restricted
- Period, area, altitude, and height of restriction
- Procedures for cancellation or modification of the restriction in event of communications loss

4-138. Temporary airspace restrictions contain four common areas. These are restricted operations areas, minimum risk routes, standard use Army aircraft flight routes (SAAFR) and air corridors, and sectors of fire and primary target lines.

Restricted Operations Area

4-139. Restricted operations area defines the dimensions of airspace where the operation of one or more airspace users is generally restricted for a short time. The ACA establishes these areas in response to the requests of ground forces commanders. Consequently, the maneuver unit commander will normally have complete weapons control status authority within an activated restricted operations area. Restricted operations areas for air and missiles can be established to maximize AMD effectiveness. In such cases, the normal AMD weapons control status will be weapons free. Restricted operations areas for AMD can be established to maximize air effectiveness. In such cases, the normal AMD weapons control status will be weapons hold.

Minimum Risk Route

4-140. A minimum risk route (MRR) is a temporary corridor of defined dimensions of airspace. It can pass in either direction through AMD defenses, a HIDACZ, or a restricted operations area. It is designed to reduce risk to high-speed aircraft transiting the tactical operations area at low altitudes. The WCS for MRR will normally be weapons tight. This allows a more flexible air defense method. AD procedures apply if friendly air does not use the MRR. Low-level transit routes are the NATO equivalent of MRR.

4-141. The weapons control status for ADA fire units whose engagement ranges intercept and activate MRR remains at weapons tight for that part of the route. Should it become necessary to change to weapons free, the commander who established it will close that particular route.

SAAFR and Air Corridor

4-142. SAAFR and air corridor are temporary corridors of defined airspace dimensions. They are established below the coordinating altitude to allow the Army commander to safely move aviation assets performing combat support and combat service support missions. They normally are located in the corps through brigade rear areas but may be extended to support logistics missions. Air corridors are restricted routes of travel for use by friendly Army aircraft and established to prevent friendly forces from firing on friendly aircraft.

4-143. The WCS for AD fire units whose engagement ranges intercept an activated SAAFR or air corridor remains at WEAPONS TIGHT for that part of the route or corridor. Should it become necessary to change to weapons free, the commander who established it will close that particular route. Procedures for deconfliction of friendly surface-to-surface missile firings and UAV operations can be found in FM 3-52.1.

Sectors of Fire and Primary Target Lines

4-144. Sectors of fire and primary target lines (PTL) are established to assist in the distribution of AMD fires. Sectors of fire for HIMAD are normally designated at battalion after review of fire unit radar coverage diagrams. The battery commander or platoon leader normally designates sectors of fire or PTL for SHORAD units. These limits must be clearly defined by right and left azimuths. Those ADA units with automated tactical data systems must know whether they are to assign and engage air targets within or beyond the stated sector boundaries.

COORDINATION

4-145. To effectively plan and fight the air and missile defense battle, coordination must be accomplished between the following organizations:

- From the AAMDC to the JFC, host nation, allies, JFACC, AADC, ACA, JFLCC, ARFOR commander, BCD, EAC ADA brigades, and corps ADA brigades
- From the EAC ADA brigade to the AAMDC, AADC, ACA, CRC, JFLCC, ARFOR Commander, corps ADA brigades, and subordinate ADA battalions. If the AAMDC is not present, than the EAC brigade coordinates as the AAMDC does above.
- From the corps ADA brigade to the AAMDC, AADC, ACA, CRC, BCD, EAC ADA brigades, subordinate ADA battalions, the corps TOC, and maneuver division TOCs.

[Figure 4-8](#) illustrates the AMD command and coordination requirements.

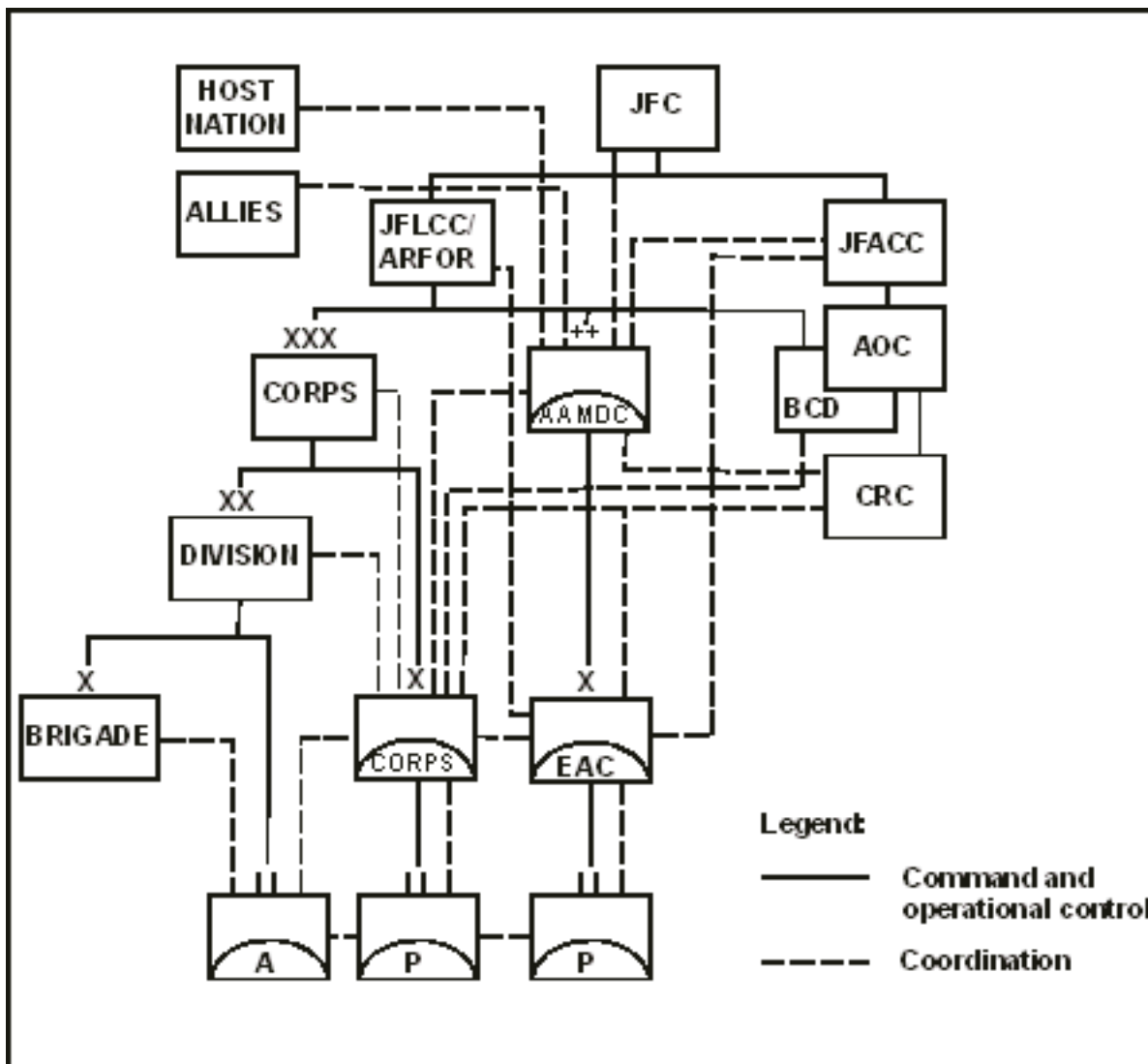

Figure 4-8. AMD Command and Coordination Requirements

LIAISON REQUIREMENTS

4-146. Liaison is essential in multinational and joint operations. Liaison personnel must be familiar with the staff and operational organizations, doctrine, and procedures of the force with which they will work.

ARMY AIR AND MISSILE DEFENSE COMMAND

4-147. AAMDC provides a liaison officer (LNO) and team to the following organizations: JFLCC, JFACC, JFMCC, JSOTF, ACA, AADC, Theater Commander, DOCC, and BCD. It is also responsible for providing a team to Allied headquarters and host nations as required.

EAC ADA BRIGADE

4-148. The EAC brigade provides a liaison team to the CRC. In addition to this liaison requirement, the EAC ADA brigade must be prepared to fill liaison requirements of the AAMDC if it is not present in theater. This includes performing the duties of the TAAMDCOORD.

CORPS ADA BRIGADE

4-149. The corps brigade provides liaison teams to the CRC and the corps HQ. Additionally, the corps ADA brigade may have to fill the liaison requirements of the AAMDC and EAC brigade if they are not present in theater. This includes performing the duties of the TAAMDCOORD.

THEATER ARMY AIR AND MISSILE DEFENSE COORDINATOR

4-150. The commander of the highest echelon Army air defense command in the theater normally acts as the JFLCC TAAMDCOORD. This could be the commander of a battalion, corps brigade, EAC brigade, or the AAMDC. The TAAMDCOORD serves as the JFLCC's principal advisor and coordinator for theater counterair and theater missile defense operations. The TAAMDCOORD performs the following functions:

- Acts as the AMDCOORD to the JFLCC, the JFACC, and the AADC
- Ensures that the Army is an integral part of joint counterair and active missile defense operations and planning at theater level
- Participates in the J3 or DCSOPS planning cells and assists in developing Army OCA and DCA input to the air operations plan as a special staff officer to the JFLCC
- Participates in the integration of Army TMD operations

- Participates in the AADC's DCA planning as AMDCOORD and Army AMD representative to the JFACC
- Ensures that corps air and missile defense requirements are integrated into joint counterair and TMD planning
- Contributes the majority of the joint force surface to air missile forces
- Deploys forces in both the combat and communications zones and influences tactical operations by shifting the AMD force between these two areas based on the concept of operation

[RDL](#)[Table of](#)[Document](#)[Download](#)[Homepage](#) [Contents](#) [Information](#) [Instructions](#)

Chapter 5

AMDPCS Operations

ADA provides protection for the force and selected geopolitical assets from aerial attack, missile attack, and surveillance. Commanders and staff are now able to use automated capabilities of the AMDPCS to plan missions, direct forces, allocate resources, and collect and process intelligence information. AMDPCS's at the brigade level will serve as the Army's AD C² interface to the joint community.

AMDPCS SYSTEM

5-1. The AMDPCS system will provide ADA commanders, staff personnel and engagement operators with fully automated capabilities to enhance the execution of air defense FO and EO. It will be comprised of a set of modular, reconfigurable and standardized vehicles, shelters, automated data processing equipment (ADPE), tactical power, communications and environmental control equipment. ADPE is upgradeable and based on common hardware and software (CHS).

5-2. The AMDPCS assists in the performance of C² functions by providing the commander and his staff with information dominance necessary to assess the situation, decide on a course of action, and direct his forces. The system automatically collects, processes, sorts, categorizes, correlates, stores, and displays air track and battle command information. Via simulation, staff estimates, or other means it assists in the development of courses of action and war gaming in order to support the commander's decision making process. Finally, it provides the commander a reliable data communications network with which to distribute his decisions; orders; and plans to superiors, subordinates, and the supported force.

DESCRIPTION

5-3. The AMDPCS components will be designed for use with variants of the Army modular command post system (MCPS), and be transported by standard vehicles appropriate to the mission and mobility requirements of the supported unit. The reconfigurable nature of the AMDPCS system design provides an inherent "Jump Tactical Operations Center (Jump TOC)" capability to support limited AMDPCS operations during

deployment; early entry or lodgment phases of force projection operations; or during reconstitution, redeployment, and movement execution on the battlefield. Appropriate configurations of the AMDPCS will be fielded at all echelons from the lowest echelons of the SHORAD platoon and sections and HIMAD fire units through EAC/corps ADA brigades and AAMDC headquarters or elements thereof.

ORGANIZATION

5-4. The AMDPCS integrates higher echelon, lateral, and subordinate command and control facilities; sensors; liaison elements, adjacent TOCs; and AMD fire units into a synergistic system capable of defeating/denying the aerial, missile, and surveillance threat. It provides the automated interface for air defense components (theater and below) to the Army Battle Command System (ABCS), which allows commanders and staffs to communicate, plan, coordinate, and control the counter-air fight. The system will be capable of collecting; storing; processing; displaying; and disseminating air and ground situational awareness (SA) information, identification and targeting data, and battle command information throughout Army ADA units and related Joint or Combined Forces. AMDPCS enhances the ability of ADA commanders, staffs, and weapon systems operators to visualize battlespace, realize situational awareness, synchronize operations with supported units throughout the theater, and defeat the enemy.

SYNERGISTIC APPROACH

5-5. The AMDPCS is the focal point for air and missile defense planning and unity of effort within the contingency theater. It provides the sole means of horizontal and vertical integration with joint forces. It facilitates the coordination and synergism of all air defense elements on the battlefield, from the AAMDC to the SHORAD platoon and sections, into a synchronized and effective counter-air force. This is accomplished by assisting the commander in the performance of the following functions:

- C² functions
- FO functions
- EO functions
- LNO functions

AUTOMATE EO AND FO FUNCTIONS

5-6. The AMDPCS fully automates the functions of FO and EO. FO are those functions required to plan, coordinate, sustain, and synchronize the air, land, and sea battle. It involves the preparation and positioning of friendly forces for maximum exploitation of enemy weaknesses. It includes the horizontal and vertical exchange of battlespace situational awareness and battle command information within ADA, as well as with other

battlefield forces. Situational awareness information involves the continuous position/location updates of key battlespace elements. Battle command information includes maps; maneuver graphics; C² information; and personnel, intelligence, operations and logistic information necessary to plan and synchronize combat operations. FO functions are accomplished to different degrees at each AMDPCS level and location. The functions associated with FO include:

- Mission planning
- Limited collection and dissemination of intelligence
- Processing tactical and administrative data
- Displaying information
- Directing forces
- Managing resources
- Providing/displaying battlespace situational awareness

5-7. EO are those actions required to defeat/deny the aerial threat. They include the process of employing sensors, detecting/classifying/identifying aerial platforms, sending ADW to posture air defense forces, and providing alerts/cueing to support engagements. The AMDPCS supports EO by providing a real or near real-time picture of the airspace. It provides the capability to coordinate A²C² with other Army, joint, and combined forces. The functions associated with EO include:

- Netting sensors
- Correlating air track information
- Assessing threats
- Directing and controlling engagements
- Geographical filtering of air tracks
- Displaying air situation
- Identifying aerial platforms
- Warning, alerting, and cueing

AUTOMATION

5-8. By automating the above functions, the AMDPCS will allow air defense forces to detect, acquire, and identify friendly and threat aerial platforms earlier and at far greater ranges. This reduces the chance of fratricide. It also allows for engagement of aerial threats at greater ranges, thereby increasing lethality. The AMDPCS provides the capability to warn the joint force of impending aerial threats. The AMDPCS receives and correlates track data information from higher echelon and subordinate air defense sensors. It processes and distributes relevant data to air defense C² centers, and disseminates engagement and battle command information. This provides for horizontal and vertical integration of the joint or combined forces from the division to theater air defense

echelons.

AMDPCS CONFIGURATION

5-9. The AMDPCS is comprised of four main elements: the S2/S3 Current and Future Operations Cell, the FDC, the S1/S4 Administration/Logistics cell, and the JumpTOC. The AMDPCS directs the brigade's tactical operations. During displacement operations the Jump TOC assumes command and control of the brigade. The physical layout of the AMDPCS is depicted in Chapter 4 at [Figure 4-1](#). This layout is flexible and may change due to terrain limitations and operational requirements. Each section within the AMDPCS will continuously monitor their respective functional areas.

CURRENT AND FUTURE OPERATIONS CELL

5-10. The S2/S3 Current Operations cell provides a working area for processing operational message traffic and informational displays related to air defense operations. It includes separate operations and intelligence maps, NBC status maps, weapon system status boards, and AMD operations status boards. To monitor the air battle, an AMD workstation (AMDWS) is installed in the battle captain's work area. This allows the commander and operations officer to monitor the consolidated air picture as displayed in the FDC van.

5-11. The S2/S3 Future Operations cell provides a working area for the brigade staff to plan and coordinate future operations. They have an AMDWS display to analyze current enemy tactics and perform trend analysis of past enemy actions. In addition, the future operations cell can perform "war gaming" simulations to determine the best courses of action to implement in order to optimize the defense against the expected enemy actions. It also contains the data processing equipment to publish and distribute the commander's decisions, orders, and plans to higher, adjacent, and subordinate units.

5-12. The Intelligence section has an All Source Analysis System (ASAS) workstation in both the Current and Future Operations areas for receiving and disseminating intelligence related messages. They maintain enemy order of battle situation maps and other appropriate data.

5-13. The brigade NBC cell consists of an MCS terminal, an NBC analysis computer, secure voice communications to subordinate NBC cells, a tactical NBC plotting map, and a working area for processing NBC information received from units.

FIRE DIRECTION CENTER

5-14. The FDC van is manned and operational on a 24-hour basis during field exercises or

periods of increased tension requiring an operational air picture. The commander maintains control of AMD units participating in the air battle from the FDC. The tactical director (TD) and tactical director assistant (TDA) use an Air Defense Systems Integrator (ADSI) workstation to monitor and control the on-going air battle and perform management by exception.

- The FDC is the senior engagement and controlling authority within the brigade. The FDC, if holding engagement authority, directs or rejects engagements for units unless there is a total loss of communications to subordinate units. The FDC does not direct the fires of Avenger or Stinger units.
- Situations may require that individual fire units be directly controlled by the brigade FDC.
- The FDC is responsible for corps early warning.

S1/S4 ADMINISTRATION LOGISTICS CELL

5-15. The S1/S4 Administration/Logistics cell performs the functions of personnel and logistics management by using CHS II equipment. It is linked to elements of the combat service support control system (CSSCS).

JUMP TACTICAL OPERATIONS CENTER

5-16. The JumpTOC will be deployed upon direction of the commander or operations officer. The mission of the JumpTOC is to assume temporary command and control of the brigade during movement of the AMDPCS.

- The JumpTOC will deploy and, at a minimum, establish voice and data communications with both higher headquarters and subordinate units and replicate AMDPCS operations for continuity until the AMDPCS assumes operations.
- The JumpTOC OIC is responsible for ensuring that JumpTOC personnel and equipment are prepared to deploy within one hour of movement notification. Status boards and overlays used in the AMDPCS must be replicated and carried by the JumpTOC to ensure continuity of operations. Upon arrival at a new location, the JumpTOC OIC will establish communications with the AMDPCS, update status boards and maps, and ensure communications to subordinate units are operational. Upon notification by the operations officer, the JumpTOC will assume control of operations.

HARDWARE AND SOFTWARE APPLICATIONS

5-17. The following paragraphs provide an overview of the AMDPCS equipment and software of the system. The AMDPCS system and operation will be detailed in FM 3-

01.71.

HARDWARE

5-18. The following paragraphs describe the equipment of the AMDPCS. The equipment is located in different shelters of the AMDPCS system. Refer to [figure 4-1](#) in chapter 4.

Fire Direction Center

5-19. The following items are located in the FDC van:

- AN/GRC-193 radio
- UHF SATCOM radio
- AN/VRC-92 SINCGARS radio
- Miscellaneous secure and non-secure telephones
- Secure fax terminal

Communications Van

5-20. The following items are located in the Communications van:

- ADSI workstation
- ADSI remote display processor
- UHF and HF TADIL-A radio equipment
- Digital switching equipment
- CTT/H-R Receiver
- TADIL-A data terminal set and associated equipment
- Air Defense Interface (ADI) equipment
- JTIDS 2M terminal
- AN/VRC-92 SINCGARS radio
- Miscellaneous secure and non-secure telephones
- Color inkjet printer

S2/S3 Current Operations Van

5-21. The following items are located in the Current Operations van:

- AN/UGC-144 Communications terminal
- AN/VRC-92 SINCGARS radio
- AMDWS
- ASAS
- Miscellaneous secure and non-secure telephones

- Maneuver Control System (MCS) workstation
- UHF SATCOM radio
- Secure fax terminal
- Color inkjet printer

S2/S3 Future Operations Van

5-22. The following items are located in the Future Operations van:

- AMDWS
- ASAS Workstation
- Secure fax terminal
- Miscellaneous secure and non-secure telephones
- AN/VRC-92 SINCGARS radio
- Color inkjet printer

S1/S4 Administration/Logistics Van

5-23. The following items are located in the Administration/Logistics van:

- AMDWS
- Two HP 735 processors
- Secure fax terminal.
- Miscellaneous secure and non-secure telephone.
- Two laptop computers
- AN/VRC-92 SINCGARS radio
- Color inkjet printer

SOFTWARE

5-24. The AMDPCS uses the following software applications:

- Automated Nuclear Biological and Chemical Information System (ANBACIS)
- Integrated Meteorological System (IMETS)
- MCS
- ASAS
- CSSCS
- Various commercial software applications (word processing, database, spreadsheet)

STAFF FUNCTIONS AND RESPONSIBILITIES

5-25. This section prescribes basic doctrine for staff functions and operations. It is intended for use by staff officers in carrying out their duties and responsibilities. A commander, however, may establish procedures and may organize the staff as necessary to conform to the mission, resources available, and level of command. They should continue to function along the direction described to maintain a commonality of understanding among units.

FUNCTIONS AND RESPONSIBILITIES

5-26. The paragraphs below describe the functions and responsibilities of each staff proponent. This is not an all-inclusive list and may be change by mission requirement or commander preference.

5-27. Brigade S1:

- Performs normal staff functions as prescribed in [FM 5-0](#)
- Prepares personnel estimates as required and makes recommendations to commander on matters relating to personnel
- Maintains continuous information displays on the personnel status of the brigade
- Develops personnel portion of OPLANs and or OPORDs.
- Responsible for the control and coordination of personnel actions in the brigade
- Collects personnel data for reporting requirements and coordinates with higher headquarters for troop replacement
- Responsible for the completion of the S1 actions and reports
- Responsible for processing awards and sympathy letters
- Responsible for graves registration
- Responsible for all chaplain activities
- Responsible for surgeon activities

5-28. Brigade S2:

- Performs normal staff functions as prescribed in [FM 5-0](#)
- Prepares the intelligence estimate as required
- Coordinates with external intelligence agencies as required
- Supervises the receipt, analysis, and dissemination of incoming intelligence (i.e., INTSUMS, spot reports, weather data, classified order of battle, KILLSUMS, etc.)
- Prepares and disseminates intelligence reports
- Advises commander on pertinent developments in the threat
- Coordinates the handling of prisoners of war (POW's)
- Supervises the execution of required measures under the brigade Emergency Action Plan (EAP)
- Develops intelligence portion of OPLANs and or OPORDs

- Develops the IPB using [FM 2-01.3](#)
- Performs other functions as directed by the commander
- Provides concertina wire for AMDPCS perimeter and ECP

5-29. Brigade S3:

- Performs normal staff functions as described in [FM 5-0](#)
- Develops operations estimates and makes recommendations to commander on activities relating to air defense operations
- Monitors and ensures that commander is updated on tactical situation and pertinent operational/support functions
- Ensures integration with all air defense assets within the corps and theater area
- Has overall tactical responsibility for the CP and integration with all elements of the brigade. Exercises positive control over battalions attached and assigned to the brigade. Responsible for provision of EW throughout the corps. Communications between the AMDPCS and subordinate units must be maintained. A communication priority for interface to the AMDPCS and subordinate units is determined by the S3. Intra-AMDPCS communications requirements will be determined by the SIGO with input from each staff
- Has overall responsibility for S2/S3, NBC, Communications Electronics cells
- Exercise primary coordination and staff supervision over other battle staff members for matters pertaining to air defense operations
- Coordinates directly with the SIGO on matters relating to communications affecting air defense tactical control
- Sets priorities and issues reconstitution orders
- Controls brigade FDC operations

5-30. Plans Officer/Assistant S3:

- Assumes S3 responsibilities in the absence of the S3
- Exercises primary coordinating staff supervision over other battle staff members for matters pertaining to planning future air defense operations
- Prepares and disseminates OPLANs and or OPORDs, incorporating risk control measures according to the commander's intent for the acceptable level of risk
- Presents operations estimates and makes recommendations to commander on activities relating to air defense operations
- Designs defense and task organizes for combat

5-31. FDC OIC:

- Responsible to operations officer and has primary responsibility for operations of the FDC van and overall air battle management operations

- Provides advice on AD operations matters to the commander and operations officer

5-32. NBC Officer/NCO:

- Provides interface with higher, lower and adjacent unit NBC sections for coordination and dissemination of information.
- Operates the MCS
- Posts NBC information to brigade situation map
- Advises the commander on matters pertaining to enemy and friendly use of NBC weapons and recommends NBC defense posture and measures
- Develops NBC portion of OPLANs and or OPORDs
- Coordinates smoke assets for the brigade

5-33. SIGO:

- Plans for the installation, operation, and maintenance of signal equipment
- Coordinates frequency allocations and assignments
- Determines method to provide signal support to meet the brigades operational requirements
- Monitors the allocation, distribution and use of communications security (COMSEC) devices and materiel
- Prepares the communications electronics annex for SOP's, OPORDs and plans

5-34. Brigade S4:

- Performs normal staff functions as prescribed in [FM 5-0](#)
- Prepares logistics estimate as required and makes recommendations to commander on logistical matters
- Maintains continuous information displays on logistical status of the brigade
- Monitors classes of supply

[RDL](#)[Table of](#)[Document](#)[Download](#)[Homepage](#) [Contents](#) [Information](#) [Instructions](#)

Chapter 6

Corps Air and Missile Defense Operations

This chapter covers the employment of the ADA brigade in corps air and missile defense operations. It describes the principles and fundamentals for the employment of corps air and missile defense operations. The current and projected air and missile threat facing US forces in the ADA brigade corps is discussed in detail. The ADA brigade must be flexible to meet the demands for air and missile defense in a wide range of environments.

CORPS OPERATIONS

6-1. As an existing peacetime headquarters capable of conducting strategic deployment, commanding Army divisions or a joint task force, and conducting sustained tactical operations, the Army corps is the focus of Army tactical doctrine. Similarly, the corps ADA brigade is the only ADA unit organized and trained to synchronize the full spectrum of AMD operations from SHORAD support of maneuver to joint TMD. The details of corps operations are covered later in this chapter and in [FM 3-100.1](#). Several general considerations affect AMD operations in support of the corps.

MANEUVER

6-2. Army warfighting doctrine is based on the concept of maneuver as a force multiplier. Maneuver affords a measure of air and missile defense protection, since mobile units are harder to target. At the same time, corps operations can involve the movement of nearly 25,000 vehicles over distances of up to 200 kilometers. AMD defenses of the corps must be mobile and must provide protection across the entire corps AO and dedicated defense of corps AD priorities.

OPERATIONAL - TACTICAL LEVELS OF OPERATIONS

6-3. The corps fights normally as part of a field army that has an operational level focus on campaigns rather than discrete operations. Sequels, or the question of what comes next, are a basic consideration in corps and corps AMD planning. The corps has a significantly greater capability and responsibility in fire support and intelligence than the divisions. This

means that OCA targeting is a real option for the corps AMDCOORD. It means also that the corps ADA brigade can greatly assist divisions in refining their air portion of the IPB.

BATTLEFIELD FRAMEWORK

6-4. Unlike its EAC counterpart, the corps ADA brigade operates within a well-defined battlefield framework of boundaries, phase lines, terrain priorities, and movement control. There are similar frameworks within each division AO. The corps ADA brigade must be proficient at moving and positioning within each of these frameworks without disrupting the scheme of maneuver.

FORCE ORIENTATION

6-5. The corps is a mobile force that normally conducts force-oriented operations. Corps AD priorities will include corps forces more often than static assets. The corps ADA brigade must be proficient at the basics of liaison and must closely coordinate with non-ADA units. The brigade must be able to design dynamic defenses of these forces based on a real understanding of their operations rather than applying stock formulas.

THE CORPS ADA BRIGADE MISSION AND CONCEPT OF OPERATION

6-6. The corps ADA brigade must not only integrate AMD operations into the joint theater air and missile defense command and control system, but also integrate or "synchronize" across all battlefield operating systems. The corps ADA brigade is organized to defeat a moderate to severe air threat, which includes a mix of current generation western and former Soviet aircraft and TMs. Air parity or better will be the normal situation in the air environment over the corps, and friendly DCA airpower will normally be available to augment corps AMD defenses. The corps order of battle will include from two to five divisions, an ACR, a COSCOM, and corps troops. It may well be a multinational or combined force. Corps AMD defense planning begins with an analysis of the commander's intent for the operation, the critical events which will affect achievement of the desired endstate, the air/missile threat to friendly operations during those events, and the resulting AMD defense requirements. AMD planning also looks systematically at the interaction of operating systems and focuses force protection on the critical systems that support the commander's intent.

CORPS ADA BRIGADE MISSION

6-7. On order, the corps ADA brigade deploys within or to a theater of operations to provide early warning (EW) and defend designated assets and activities from aerial attack, missile attack, and surveillance. This mission may require the brigade to self deploy by

tactical lift or strategic lift. Elements of the brigade may deploy early to protect a lodgment or early entry operations. The brigade may operate initially under the operational control of the land or air component commander as corps forces flow into theater. During all phases of the operation, the brigade must be able to integrate into the theater air and missile defense system. It will defend against TMs, cruise missiles, aircraft, and attack helicopters. Corps AMD missions can range from TM defense of corps, JFC activities, or assets to reinforcing coverage of a divisional tactical maneuver. The brigade's mission is to allow the corps commander the freedom to maneuver and to preserve the corps' combat power for offensive operations.

EMPLOYMENT OF CORPS ADA WEAPONS

6-8. Effective HIMAD defense of the corps against a mid-intensity air/TM threat requires at least two HIMAD battalions. The corps ADA brigade organization for combat normally includes two Patriot battalions and may be task organized to include a THAAD battery. HIMAD units normally are employed GS to the corps and may reinforce the division in an integrated area defense.

Defense Design

6-9. HIMAD normally fights in battalion task forces with a combined area ABT and point TM design. Batteries assigned the TM fight should be the base piece of the Patriot defense design. A synchronized corps AMD plan can provide planners the flexibility to protect both static assets and maneuver forces from air and missile attack. The key to a successful corps AMD plan is determining where and when to mass forces against the enemy by synchronizing the AD support of the corps and divisions scheme of maneuver.

Maneuver Support

6-10. The principle difference between corps and EAC HIMAD operations is that corps AD priorities are usually mobile. The corps ADA brigade staff must understand how the corps moves and maneuvers and must understand movement planning factors. A Patriot battery near the rear of a reinforced brigade march column will cross the LD several hours later than one near the front. If required, this precludes any possibility of covering the maneuver brigade. Therefore, an additional component of a corps HIMAD defense design is a HIMAD scheme of maneuver closely integrated into corps and division march tables. HIMAD units can expect to support the divisions in a GS-R role by reinforcing the fires of the divisional SHORAD battalion.

6-11. Division commanders are the approval authority for positioning and movement within their AOs. During a corps maneuver, HIMAD fire unit may be required to move. This requires detailed movement coordination by the brigade staff with division as well as

corps movement control centers and G3s. Key to this effort are the brigade LNOs to the divisional ADA commanders who are the AMDCOORDs. They are responsible to ensure the execution of an integrated corps AMD plan within their sector. Divisional ADA battalions can play a vital role in coordinating both the movement and terrain required by corps HIMAD units.

6-12. In mobile operations, a Patriot heavy task force will normally operate forward by laying down long range coverage over the advancing corps. As divisions meet and engage the enemy, Patriot may be pushed into the division rear areas to strengthen defenses in the main battle area (MBA).

Survivability

6-13. Corps AMD missions normally require HIMAD to emplace well forward within the range of enemy rocket artillery but outside the range of tube artillery. Maintaining a degree of mobility, OPSEC, and physical protection consistent with the threat enhances HIMAD survivability. Division commanders may incur the responsibility to protect HIMAD units within their AO, dependent upon command and support relationships, by providing dedicated engineer, security, and chemical decon/smoke assets to enhance Patriot's survivability in the forward area. Defending the unit against ground, air, or missile attack is a requirement to any AMD plan. Survival is the primary mission of an ADA unit under attack. The tempo of corps maneuver may make unit survivability moves unnecessary. However, a survivability movement plan should be developed. Integrating HIMAD units into maneuver unit march columns can also enhance security while moving.

6-14. Both HIMAD and SHORAD electronic emissions must be treated as a specific tactical decision. They must be managed closely at battalion or brigade level. This includes Patriot radar mapping during emplacement and SHORAD sensor emissions in a theater where the enemy possesses significant ELINT capabilities. HIMAD units must maintain the agility to obtain an air picture from various external sources, including adjacent units. The brigade provides EMCON guidance to subordinate battalions.

6-15. If the ground security threat is sufficient, HIMAD units must be reinforced with dedicated security forces. HIMAD battery commanders must integrate their ground defense with other local ground commanders. In all events, however, an ADA commander remains responsible for the ground defense of his unit. A ground attack represents a change of mission from AMD to infantry. Therefore, the commander's plan must incorporate sound infantry tactics by orienting not only the threat but also the priorities of protection within the perimeter. All supporting and organic weapons and soldiers must be integrated into a coherent fire support plan, scheme of maneuver, and C² plan.

6-16. HIMAD self-defense against air and missile threats is enhanced by dedicated organic

SHORAD point defenses. Sound positioning and early warning is critical to the viability of Stinger defenses. The Patriot air picture, particularly in a TM defense, might not be useful to organic Stinger teams. Therefore, the corps ADA brigade early warning plan should consider how to integrate HIMAD Stinger teams into the corps SHORAD early warning plan.

Sustainment

6-17. HIMAD units are organized with sufficient crews to sustain 24-hour AMD operations. The brigade establishes the minimum number of fire units to be at specified levels of readiness. Within these guidelines, battalions manage the readiness of subordinate fire units to ensure that required rearming and refitting is accomplished. Fire unit commanders closely manage crew rotation and rest plans to ensure the fire unit remains at the required readiness levels. Pushing the radar ORF forward will assist in keeping units operational and maintain the required level of readiness. Missile resupply planning and the identification and stockage of critical authorized stockage list (ASL) are important requirements for the brigade to consider. Chapter 8 provides further details on sustainment planning. Sustainment includes the ability to reorganize combat power in case of losses. Therefore, batteries and battalions must establish and maintain proficiency in BDAR procedures.

SHORAD OPERATIONAL CONCEPT

6-18. Corps ADA brigade SHORAD operations involve one or more SHORAD battalions equipped with Avenger or MANPADS weapons. In mobile operations, The brigade's SHORAD units are normally assigned missions that free divisional SHORAD from having to deploy to protect supported task forces until the force itself deploys. Also, SHORAD deploys in the division and corps rear to protect high value assets and activities against aircraft penetrating the forward defenses. The brigade operational concept for SHORAD employment focuses on imperatives in the following paragraphs.

Reinforce Divisional ADA

6-19. Although not an automatic mission, reinforcement of divisional AMD defenses will be a frequent corps SHORAD task. Corps SHORAD ground and air mobility enables the brigade to rapidly shift coverage across the corps. Corps SHORAD battalions maintain proficiency in division operations. Habitual training relationships with the divisions should be maintained whenever possible.

Integration

6-20. SHORAD defenses are integrated into the corps early warning structure. SHORAD

commanders at all levels integrate their AMD with those of any adjacent SHORAD or HIMAD fire units. Support or command relationships will establish this integration.

Limited Visibility Operations

6-21. Corps Avenger units must be prepared to provide limited night AMD coverage. This requires a battle readiness plan, which is managed at PLT level. Avenger units fighting at night require direct early warning. The corps brigade can ensure this through links to organic HIMAD units. Divisions can supplement this link with their own organic radar assets. Avenger night missions might include defense of Patriot fire units if there is a significant night-capable air threat that cannot be met by HIMAD mobility.

OFFENSIVE OPERATIONS

6-22. Corps offensive operations combine maneuver and attack at a high tempo to unhinge critical enemy support systems. The corps ADA brigade orchestrates an integrated plan in support of corps operations. The AD priorities and plans described below are possible options. METT-T considerations will drive actual AMD plans.

MOVEMENT TO CONTACT OR APPROACH MARCH

6-23. In an approach march, the corps moves along multiple routes in march columns. The enemy situation is typically unclear. Contact prior to the LD is possible, though not likely. Lead brigades depart assembly areas on multiple routes and conduct covering force operations. A corps advance element follows and normally includes forward C³ and LNO teams, MI collection units, forward CSS, and corps/divisional fire support. The division with task organized corps support then follows the corps advance element on as many as eight routes per division. All other units follow the divisions. The corps advance element will halt short of the LD and establish support sites, fire support positions, and communications. Finally, the divisions will pass through the corps advance element, rearm and refuel, and conduct a movement to contact or attack. In a movement to contact, the corps moves from assembly areas and maneuvers to find and attack an enemy force. A covering force leads under corps or divisional control and operates well beyond the main body. Behind the covering force follows the advance guard, which is ready for immediate commitment upon enemy contact. The corps main body carries the bulk of corps combat power. It moves in task organized march columns to facilitate rapid deployment and hasty attack operations. Up to three brigades may provide flank and rear security of the main body during movement.

Corps Key Events

6-24. Key events include the movement of the lead brigade and the covering force

operation; the movement of the divisions and follow-on units; rearm and refuel operations conducted en route; and corps actions on enemy contact.

Corps AD Priorities

6-25. While not pre-established, HIMAD priorities may include the corps main effort, corps aviation, ATACMS, the supporting effort, and COSCOM assets. COSCOM priorities will be class III and V supplies. Force oriented SHORAD priorities may include the corps TAC, MSRs, ROM sites, and C² nodes. Area oriented priorities may include the full spectrum of counter RISTA operations.

Corps ADA Brigade Task in Support of Corps Operations

6-26. During a corps movement, some divisional AMD may be integrated into divisional march columns and some may be pre-positioned. To free march ordered units from having to deploy before their supported maneuver elements, corps AMD forces may be tasked to provide AMD coverage of critical routes well forward. Corps HIMAD missions could include TM defense of critical static assets such as a corps intelligence downlink facility. Patriot might also provide long range coverage of the corps advance element and may even move with the advance element of an approach march. Corps SHORAD units might reinforce coverage of the corps' covering force. SHORAD platoons could be OPCON to divisional ADA battalions for the duration of an approach march to provide route defense of divisional march columns.

ADA Scheme of Maneuver

6-27. Up to four Patriot batteries and an Avenger battery may move with the advance element of a corps approach march. The integration requirements of a division march may require all elements of a march column, including GS Patriot units, to be OPCON to the march unit commander for the duration of the march. Patriot and SHORAD batteries may defend forward to the LD. In a movement to contact, the corps relies on speed, tactical dispersal, and DS SHORAD units for AD protection. The HIMAD scheme of maneuver orients on the estimated location and time of contact with the enemy main body. HIMAD units move with the main body, deploying to provide area coverage as the corps approaches this point, but remaining flexible until the shape of the corps AO during the attack becomes clear.

EAC ADA Support

6-28. The length of the corps movement may preclude complete AMD coverage, requiring augmenting coverage by DCA fighters. EAC AMD coverage is also coordinated as feasible.

6-29. [Figures 6-1 through 6-3](#) illustrate a notional flow of a battle with the air and missile defense coverage. Both the corps and EAC AMD brigade are depicted. The above paragraphs describe the actions in the figure.

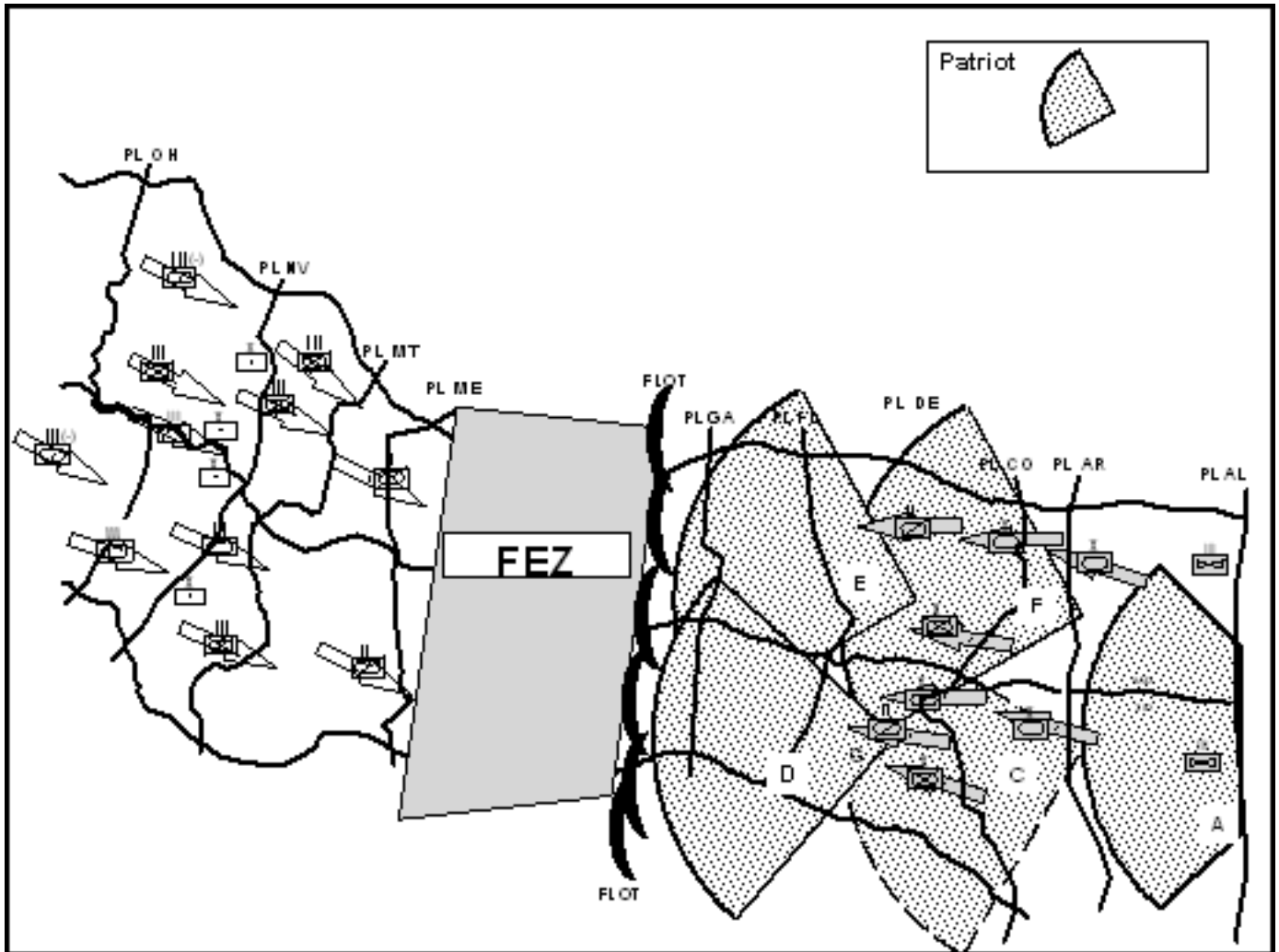

Figure 6-1. AMD Coverage for Corps Movement Operations

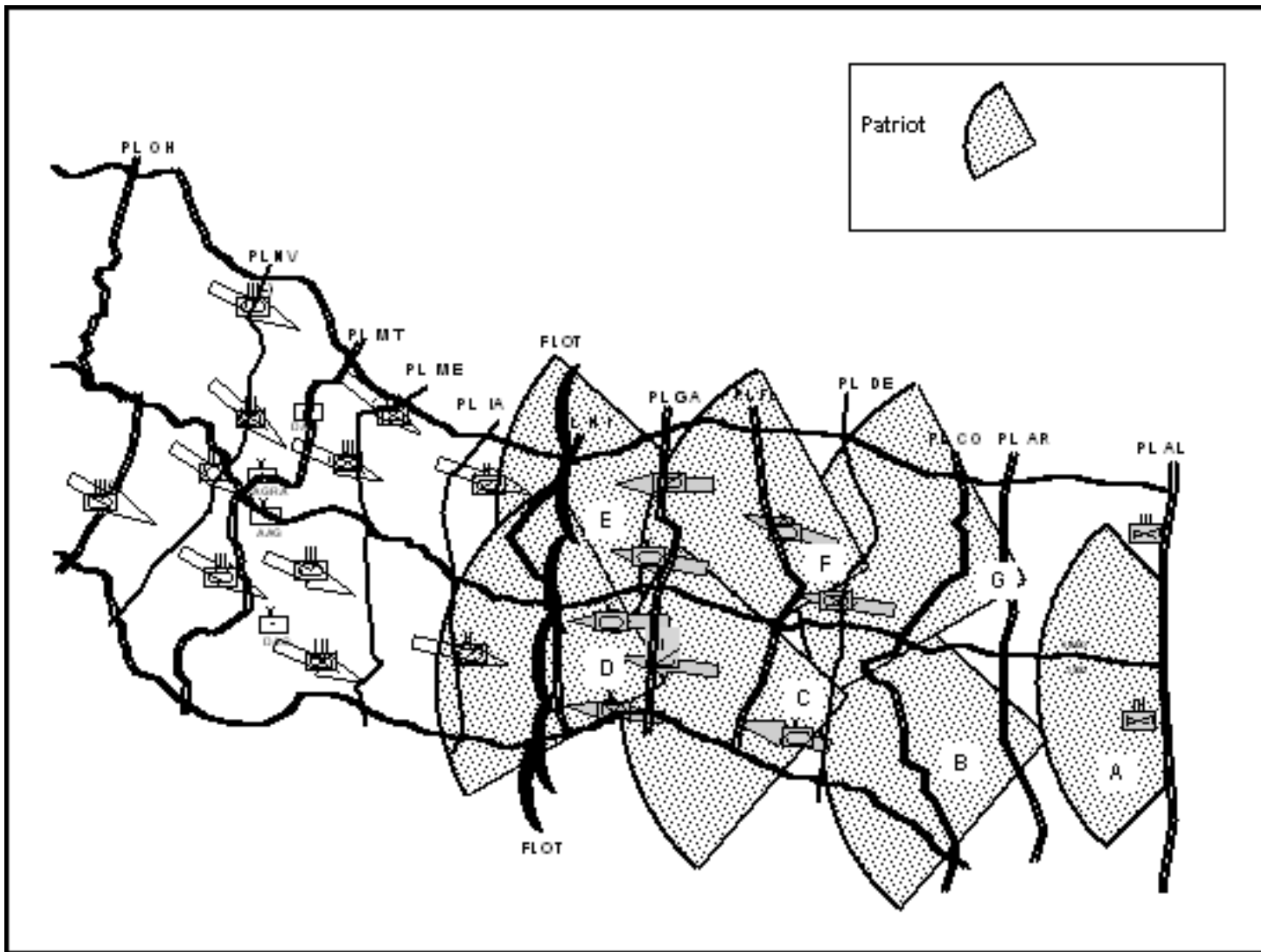

Figure 6-2. AMD Coverage for Movement to Contact Operations

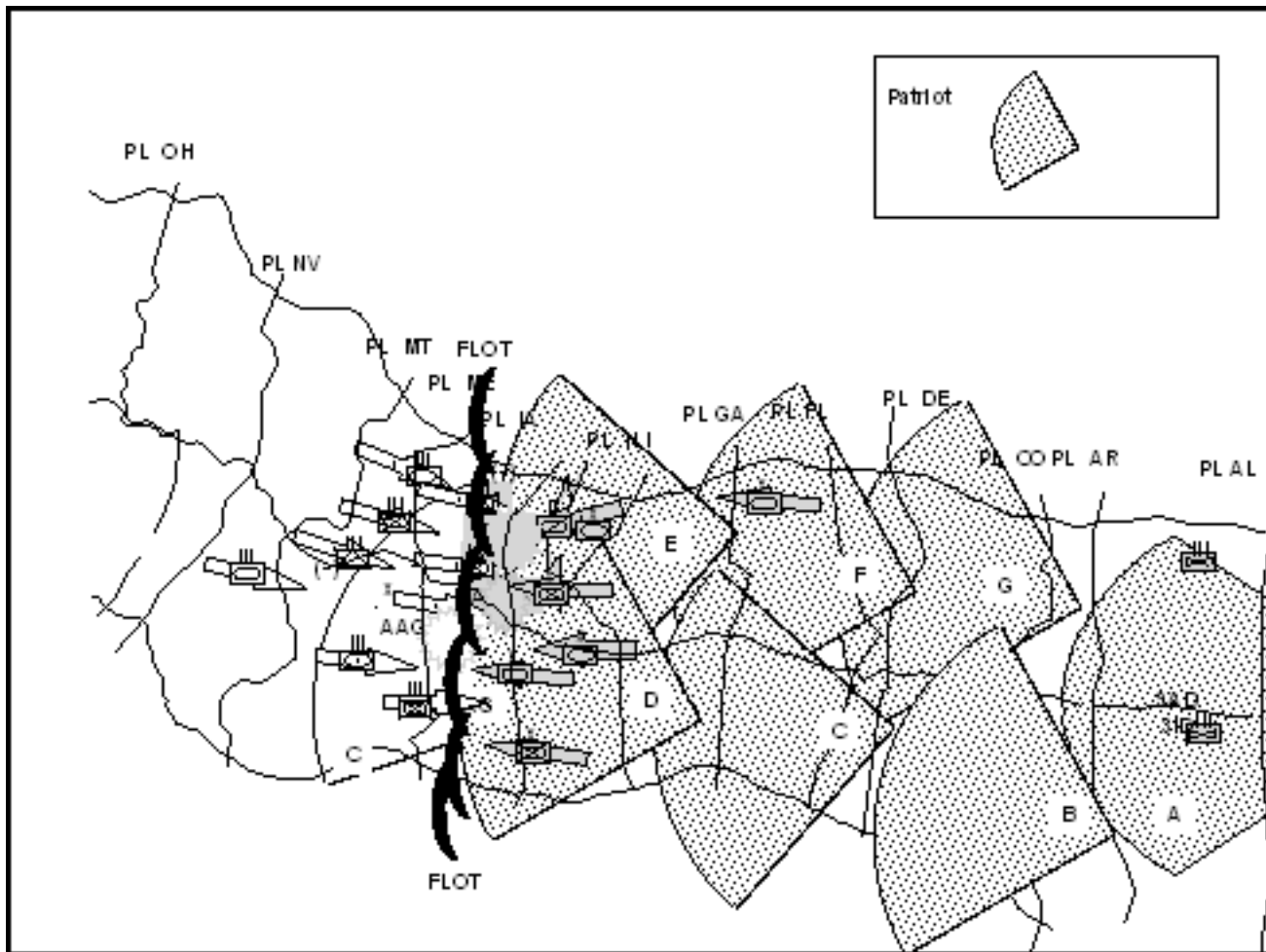

Figure 6-3. AMD Coverage for Attack Operations

CONDUCT HASTY OR DELIBERATE ATTACK

6-30. The corps typically attacks as part of a field army operation to defeat the operational reserves of an enemy field army. The corps conducts a movement to contact, deploying when an enemy division is located by the covering force. Lead divisions conduct a hasty attack to fix and destroy enemy lead regiments, while trail divisions maneuver to attack the enemy divisional second echelon. Divisional combat power is reinforced with corps MAP, FA, and AMD assets. Reinforcing corps FA attacks the second echelon under the direction of the lead divisional cavalry and other intel assets. Engineers conduct countermobility operations in support of the lead division and mobility operations in support of the attacking trail division. The corps aviation brigade conducts deep attack operations to reduce and delay the division second echelon. Because of the inherent uncertainties of maneuver, the most vulnerable friendly element is command and control. Additional risks include bypassed units and flank counterattacks. To mitigate these risks, the corps implements C³ countermeasures and a deception plan to undermine the enemy intelligence and C² systems. The corps centrally manages deception operations. Corps ADA units may receive tasks to support the portrayal of the deception plan. In a deliberate attack, the corps penetrates the main defensive belt. Lead divisions attack to penetrate while trail divisions

follow and attack to exploit success. During the attack, ground or air cavalry guards the corps flanks. Corps artillery and aviation attack enemy counterattack forces and C² nodes. Engineers provide mobility support to the trail division. When the penetration is forced, trail divisions pass through the lead divisions and attack through to the corps objective.

Key Corps Events

6-31. Corps events during hasty or a deliberate attack could include several different missions. The corps could take part in a passage of lines; the movement of large units along routes; the movement to contact of brigades in battle formation; the attack of the enemy divisions; and the corps deception plan.

Corps AD Priorities

6-32. An attack is a highly fluid operation with many potential branches and sequels. Movement provides some measure of passive AD protection, but a successful corps attack must achieve surprise through speed or deception and this requires a clear concept and accurate intelligence. Based on this, corps AD priorities could include key C³I elements, such as the corps TAC CP and intel facilities; a passage of lines; key aviation assets; maneuver forces in contact; the deception plan; and key FA assets.

Corps ADA Brigade Task in Support of Corps Operations

6-33. A key AMD task during this operation is to support the momentum of the corps. Corps ADA reinforces the divisions with GSR SHORAD and GS HIMAD coverage. Corps HIMAD protects the corps as a whole and attacks high performance aircraft in the MBA which are driven up into its envelope by FAAD defenses. Corps HIMAD missions could also include TM defense of the corps main CP, key corps passage points, and the corps intelligence facility. Corps SHORAD can sustain divisional momentum by protecting LOCs and critical division rear assets, allowing divisional ADA to mass in the MBA. Corps SHORAD missions could include a battery GSR to the main effort; corps passage points; corps main and TAC CP; aviation FARPs and PZs; deception support; critical routes forward to division rear boundaries; and key corps assets in the division AO, such as artillery, intelligence, or CSS.

ADA Scheme of Maneuver

6-34. The brigade staff plans the HIMAD coverage for the meeting engagement. The HIMAD scheme of maneuver is timed to provide both mutual support and at least one to two hours of coverage over critical maneuvering forces. It optimally provides for the arrival of Patriot units to protect the MBA as the corps initiates the meeting engagement. Avenger units with missions in a division AO will move with divisions so as to provide

coverage of an asset as soon as necessary. AMD planners protect maneuver forces by successfully employing the AD principle of mass and AD guidelines of overlapping fires, mutual support, and early engagement.

EAC AD Support

6-35. In addition to fighting the DCA battle beyond the FLOT and OCA attacks of enemy airpower, DCA coverage will normally extend above or to the flanks of the corps. Corps rear assets such as GS facilities will not normally displace forward during the movement to contact. As the corps LOCs extend, EAC ADA can support the corps by defending static rear assets and freeing corps HIMAD to defend the movement to contact. It may also support the corps deception plan.

DEFENSIVE OPERATIONS

6-36. The corps is organized and equipped to defend against an enemy force of up to three corps equivalents. Defensive operations may be conducted to hold key terrain, to reduce or divert enemy combat power, or to buy time until the corps has enough combat power to resume offensive operations.

DEFENSIVE FUNDAMENTALS

6-37. In a mobile defense, the corps seeks to engage and destroy an attacking force, using fire and maneuver, and counterattack by a large reserve. In an area defense, the corps seeks to deny the enemy access to key terrain or facilities and employs a smaller reserve and a network of interlocking defensive positions. Based on a thorough IPB, both types of defense seek to prevent the enemy from concentrating combat power by defeating each echelon of his attacking force in detail.

6-38. The corps commander shapes the battlefield to deflect the enemy into engagement areas where he can be destroyed or blocked. This is achieved by using fires, terrain, obstacles, offensive, and defensive maneuver throughout the depth of the MBA, deception, information warfare, and the enemy's own momentum. In the deep operations area, for example, corps and theater level fire support assets attack follow-on elements to reduce them and delay their arrival in the MBA. Forward of the MBA, the corps conducts security force operations to deny the enemy the element of surprise; to disrupt his efforts to locate friendly dispositions; and to harass, delay, or defend against him if necessary. In the MBA, units prepare fighting positions and terrain in depth to disrupt enemy maneuver. Fire support plans are prepared to attack critical enemy AUTLs, including C², fire support, and logistics to unhinge the synchronization of the enemy plan. The corps develops a defensive scheme of maneuver which masses combat power at the decisive time and place. It also organizes a large reserve, possibly up to division size. Deception and strict operational

security characterize all good defensive preparations. Finally, the corps retains the flexibility to meet the enemy's initiative, neutralize it, and quickly exploit opportunities for counterattack. Potential sequels to a defensive operation include reestablishing a defense against attack by a follow-on enemy element or counterattacking an enemy field army. [Figure 6-4](#) depicts the organization of the defense.

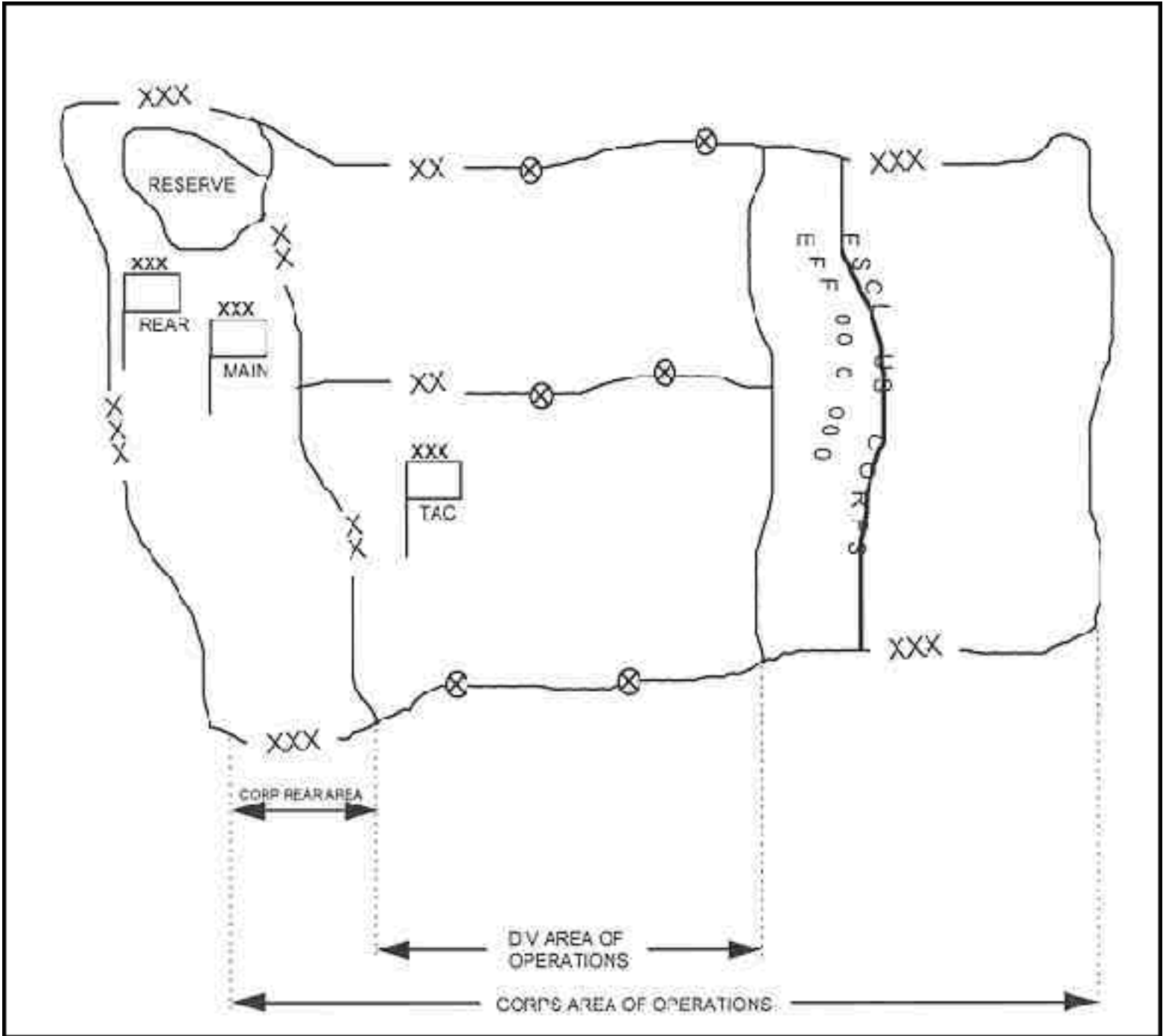

Figure 6-4. Organization of the Defense

CORPS ADA SUPPORT OF THE DEFENSE

6-39. Synchronizing defensive actions and seizing the initiative requires tight command and control by the corps. In the defense, corps fire support systems have a critical role in attacking the enemy and expend large quantities of ammunition. Corps maneuver forces seize or hold key terrain and counterattack the enemy. The corps reserve is the means of striking the decisive blow to an enemy attack. The enemy will attempt to attack all of these with ground and aerial fire support. The corps ADA brigade therefore contributes to the corps defense by neutralizing air/missile attacks against critical assets and disrupting the synchronization of the enemy's firepower. By attacking enemy aerial reconnaissance, corps AMD operations contribute to the counter-reconnaissance battle by denying the enemy critical intelligence. The corps and the ADA brigade plan for the defense by answering the following questions:

- Where and when is the enemy most vulnerable?
- When, where, and how can those vulnerabilities be exploited?
- What specific conditions would trigger exploitation of those vulnerabilities?
- What is the worst thing the attacking enemy can do to the defending force?

Key Corps Events

6-40. Key corps events are preliminary interdiction and deep attack operations; covering force operations and the recon/counter-recon battle; identification of the enemy main and supporting effort engagement operations in the MBA; employment of the reserve; and counterattack.

Corps AD Priorities

6-41. Corps events during defensive operations could include various missions. Corps AD priorities may be divisional and corps MAIN and REAR CPs; ammunition supply points; the reserve force; covering force or MBA units in contact; denial of hostile RISTA; and route defense of key MSRs.

Corps ADA Brigade Task in Support of Corps Operations

6-42. Corps HIMAD units provide a dense area defense by integrating with adjacent corps, EAC, and joint AD operations. Corps SHORAD may provide point defense of key C² and logistics assets. SHORAD may also defend assembly areas, routes, obstacle crossing sites, and passage points. SHORAD and HIMAD fires must be massed to meet enemy air attacks.

ADA Scheme of Maneuver

6-43. SHORAD will maneuver with supported maneuver forces. HIMAD defenses are

oriented to support the planned scheme of maneuver when the corps resumes the offensive. This could involve movement of a Patriot heavy task force through the forward task force. The corps brigade may task Avenger platoons to act as a reaction force. They must be ready to maneuver rapidly by ground or helicopter airlift in response to enemy action or fire unit outages.

EAC AD Support

6-44. If the main effort of the enemy air campaign is to be directed at or through the corps AO, reinforcement by EAC AMD units may be required. DCA operations will be ongoing throughout the theater, but dedicated fighter engagement zones or areas of responsibility may be requested forward or to the flanks of the corps. [Figure 6-5](#) depicts the rear area of defense.

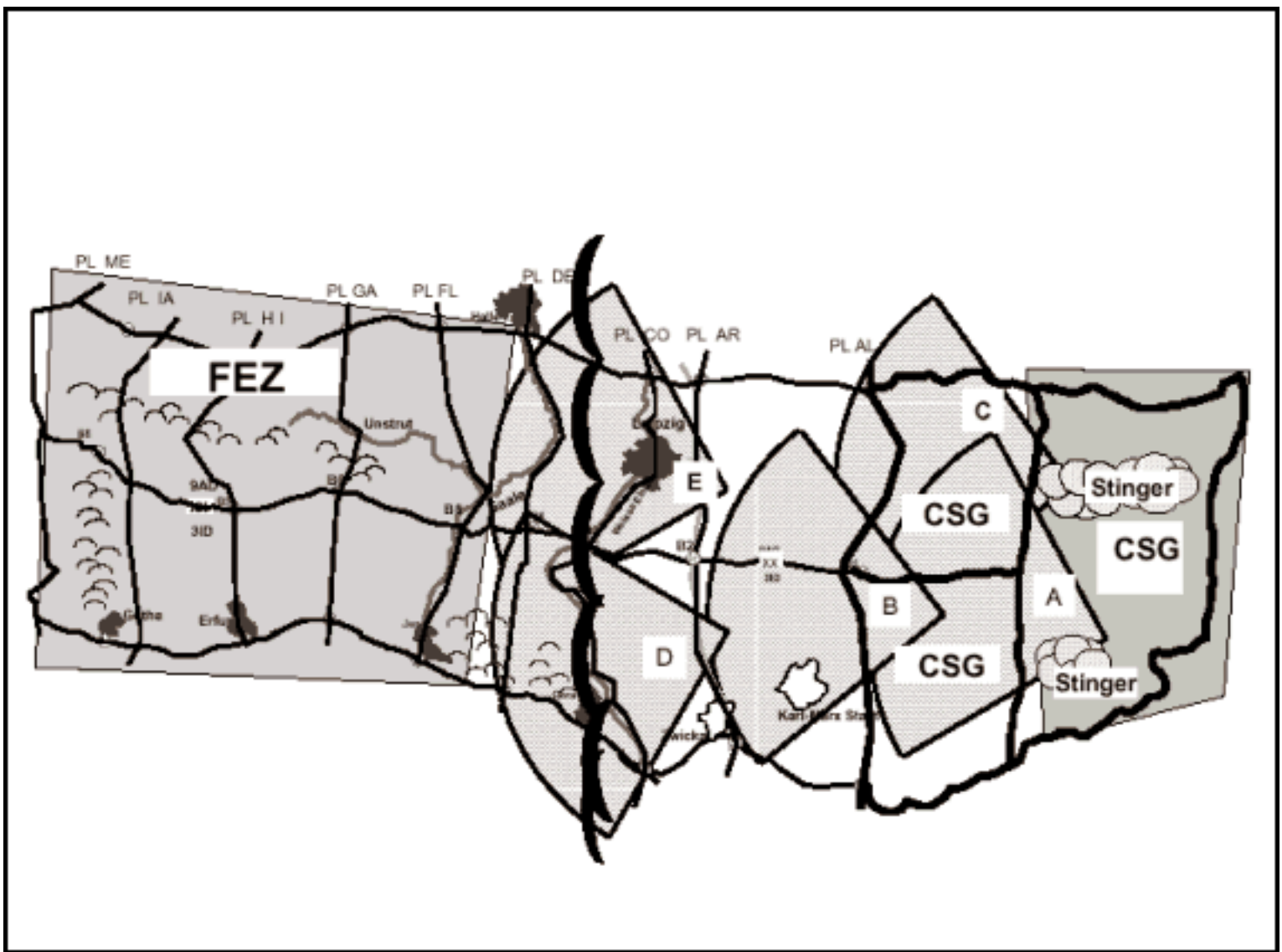

Figure 6-5. Rear Area Air Defense

RETROGRADE OPERATIONS

6-45. There are three types of retrograde missions: delays, withdrawals, and retirements. Units with a delaying mission are gaining time for friendly forces without becoming decisively engaged with the enemy. An opposed disengagement of a unit in contact is a withdrawal. Rearward movement of a unit not in contact is a retirement.

RETROGRADE FUNDAMENTALS

6-46. Retrograde operations pose difficult challenges for the corps in several areas. Leaders must counteract confusion and soldier fears of possible isolation or defeat. Units must move back along contracting LOCs and reposition repeatedly within a shrinking or shifting corps AO. The corps logistics system must move units and shift lines of support. If the enemy force is aware that a retrograde is underway, it will aggressively probe and attack the corps all along the FLOT. A highly synchronized plan, developed rapidly under difficult circumstances, is required to prevent the situation from deteriorating to chaos.

6-47. A corps retrograde involves all three types of retrograde operations. It begins with a convincing deception plan, augmented by all possible OPSEC measures. The corps retrograde plan synchronizes the timing of withdrawals and prescribes how much combat power and logistics must be kept battle ready to protect the force. The corps plan also establishes sequential boundaries and routes for the force. In the forward area, a division size delaying force maneuvers and harasses the enemy. It maintains contact, forcing him to deploy repeatedly to attack, but does not become decisively engaged. Elements of the delaying force withdraw to supplementary positions, usually at night or under cover of smoke. Behind the delaying force, forces retire to the rear in accordance with detailed movement tables. Engineers conduct mobility/countermobility operations. Corps transportation assets backhaul supplies and transport less mobile CSS units to supplementary positions. The corps retains a small reserve during retrograde operations and positions it well forward to counteract enemy penetrations with spoiling attacks. The retrograde operation ends when the corps attains a more favorable force ratio or is repositioned on terrain that is more favorable.

CORPS ADA SUPPORT OF RETROGRADE OPERATIONS

6-48. During a retrograde, the quickest means for the enemy to launch an exploitation attack is with airpower, attacking to the depth of the corps to destroy units on the move and sew confusion. The corps ADA brigade maintains HIMAD area coverage over the corps and DS/GSR SHORAD support to critical assets and activities. The key requirement for the brigade during a retrograde is to maintain positive control over unit location, movement, and operations. For example, if corps SHORAD units are reinforcing AMD defenses along the FLOT there is a significant risk of their being left behind in the

confusion of a withdrawal, especially as the ADA battalion and brigade CPs displace to the rear. In this case, a command relationship of OPCON or attachment may have to be temporarily established with a forward maneuver unit. Patriot battery commanders may establish physical liaison with a nearby maneuver unit to ensure that they receive current information on the ground situation. A clear succession of command SOP ensures that someone is continually in command of brigade operations during a retrograde. In the event that supporting communications cannot be established, HIMAD units must be prepared to fight autonomously with voice command links only to the FDC.

Key Corps Events

6-49. Corps events during retrograde operations could include several different missions. The corps may participate in covering force delaying operations; passages of lines; any river/obstacle crossings; tactical movement operations; enemy penetrations; and commitment of the reserve.

Corps AD Priorities

6-50. Priorities during a retrograde may change as the operations progresses. Corps AD priorities may include covering forces; units in contact; passages of lines; river and obstacle crossing operations; key logistics units; or facilities.

Corps ADA Brigade Tasks in Support of Corps Operations

6-51. Corps AMD missions may resemble those of a movement to contact operation in reverse order. HIMAD units provide area coverage forward to the covering force if possible. The Patriot heavy TF withdraws early to reestablish long range and high firepower coverage over the corps rear or subsequent forward area. SHORAD protects areas where key forces will concentrate, such as passages of lines or river crossings. The brigade maintains coverage over the corps rear where logistics units are displacing themselves and huge stocks of supplies.

ADA Scheme of Maneuver

6-52. The corps ADA brigade implements a rearward scheme of maneuver in support of the retrograde, sequencing the movements not only of Patriot and Avenger batteries, but also of CPs. As with a forward scheme of maneuver, movements are planned backward from the anticipated endstate defense of the corps in its subsequent location. HIMAD units must be prepared to move several times a day, emplacing only enough equipment to conduct engagement operations. Corps SHORAD moves with supported units.

CAS Support to Retrograde Operations

6.53. DCA fighter coverage of the corps is critical during a retrograde. The corps will likely receive priority for CAS to protect its withdrawal. This reinforces the need for friendly air supremacy over the corps during this operation. The corps AMDCOORD initiates, through the FSCOORD, CAS coordination early in the retrograde planning phase. [Figure 6-6](#) depicts a retrograde operation.

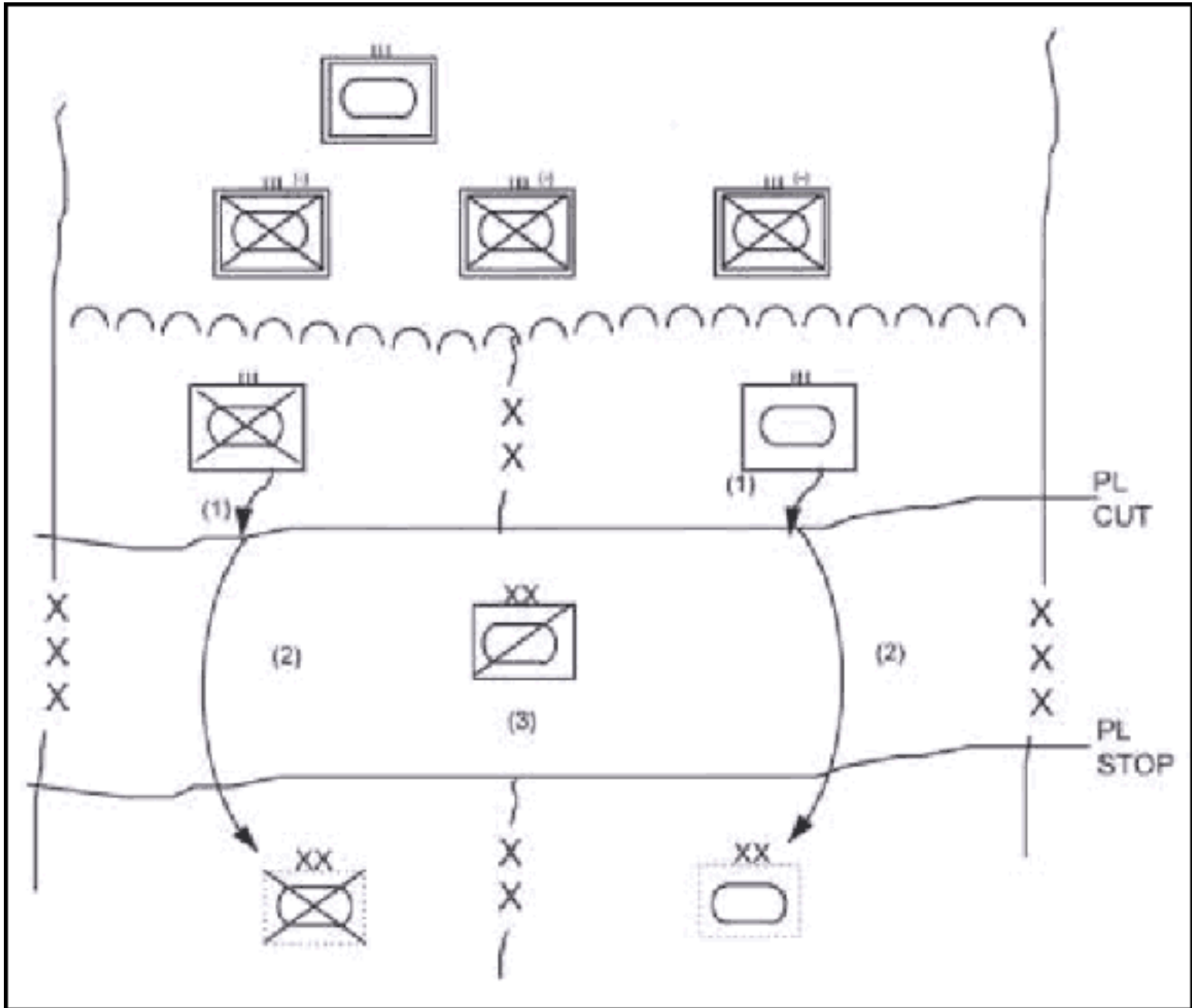

Figure 6-6. Retrograde Operations

ENCIRCLEMENT OPERATIONS

6-54. Massing friendly strength against enemy weakness can involve flank attacks or

encirclement of large enemy formations. In encirclement, the corps attacks a large force to enclose and capture or destroy it. Encirclement usually begins with a corps' penetration attack through enemy defenses and exploitation along converging axes. Corps forces link up around encircled enemy forces and establish a hasty defense against counterattack by the enemy reserve. Inside the defensive ring, positions for attack of the encircled force are prepared. Finally, the corps undertakes operations to reduce or destroy the encircled force. Risks associated with this operation include dividing the corps force and exposing it to possible counterattack on the flanks. Linkup operations also entail some tactical risk. In situations where these risks can be minimized and the corps maneuver capabilities maximized, encirclement can accomplish operational objectives with minimum loss of combat power.

KEY CORPS EVENT

6-55. Key core events are the penetration attack and subsequent exploitation along both axes; linkup operations; establishment of a hasty defense and inward focused attack positions; and attack of the encircled force. [Figure 6-7](#) illustrates a corps encirclement.

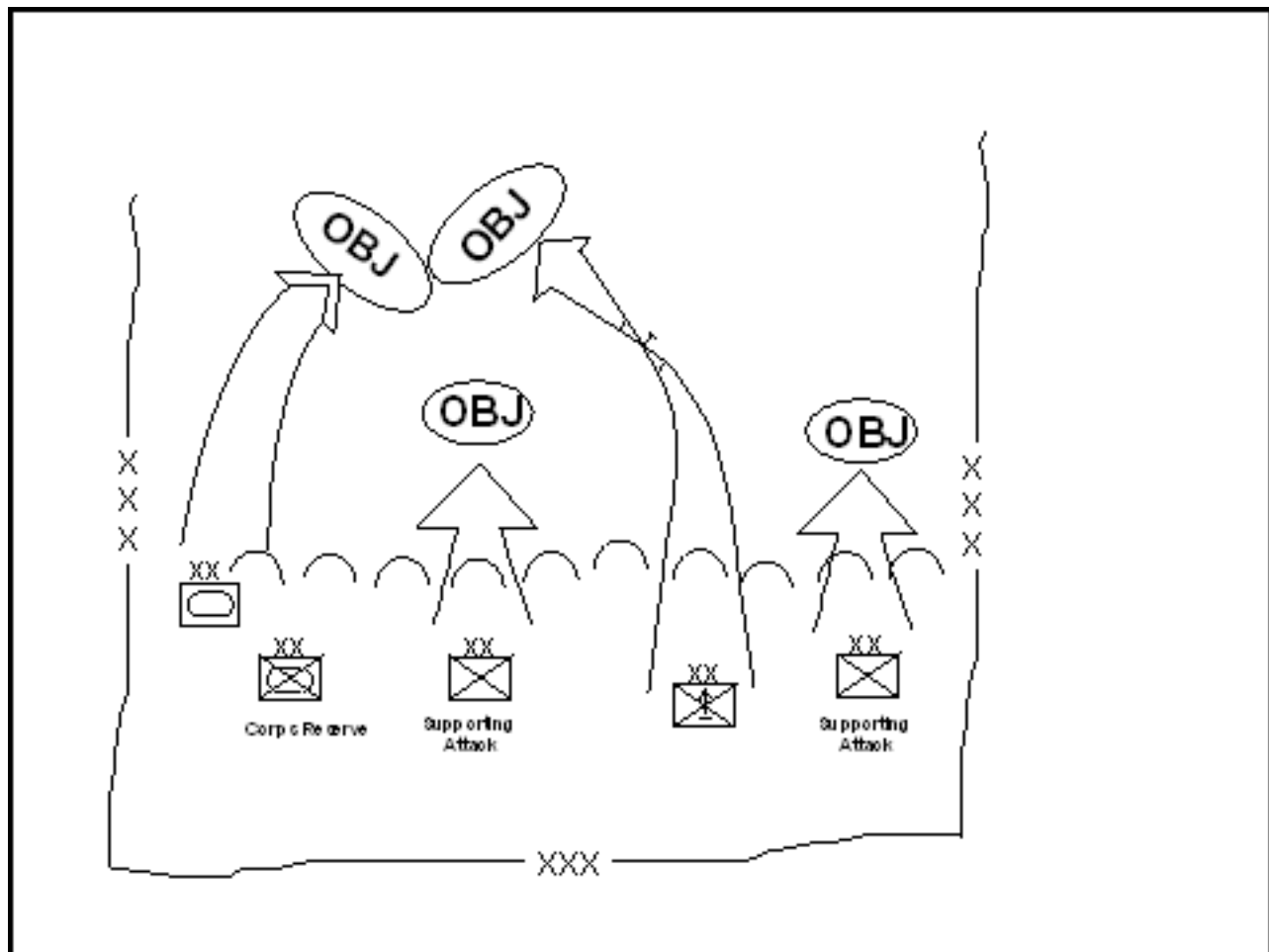

Figure 6-7. Corps Encirclement

CORPS AD PRIORITIES

6-56. The main mission is protection of the maneuver force in contact. Other AD priorities could include C³I assets, aviation assets, and fire support elements. AMD must protect the linkup operation from air attack.

Corps ADA Brigade Mission

6-57. Corps AMD missions for an encirclement are similar to missions in support of the attack. The corps ADA brigade also protects the linkup as well as the inner and outer flanks of the encircling forces.

ADA Scheme of Maneuver

6-58. AMD must meet the challenges of extended forces and rapid movement associated with the exploitation and encirclement. Depending on the size of the enemy force, HIMAD defenses may be extended over the enemy AO to deny his aircraft any sanctuary.

EAC AD Support

6-59. The maneuverability and reach of DCA fighters can effectively reinforce corps AMD during rapid exploitation and encirclement. OCA operations can attack enemy helicopter assets both in the enemy reserve and within the encircled force.

CROSS AN OBSTACLE

6-60. In this operation, the corps breaches and passes through an obstacle (such as river or fortifications) and continues operations. The location of the crossing site is concealed as long as possible. Breaching and crossing operations must be done swiftly and the "far side" must be secured to a depth of 30-50km. Crossing operations might be undertaken "from the march" or after a short buildup. As combat power masses near the breach/crossing site, it becomes a lucrative target for enemy airpower.

KEY CORPS EVENTS

6-61. Key corps events include the deception operation and securing crossing sites. Another key event may be the attack to secure the bridgehead line.

CORPS AD PRIORITIES

6-62. Corps events during crossing of an obstacle could include several different missions.

AD protection priorities may consist of bridge/breach sites, routes to passage points and crossing sites, and near and far side assembly areas.

Corps ADA Brigade Tasks in Support of Corps Operations

6-63. Depending on terrain, corps HIMAD can provide point TM and area ABT defense of the most critical bridging sites or staging areas for bridging assets or crossing units. In a corps crossing/breach operation, corps SHORAD is the lead for point defense of crossing sites and routes leading to them. Since the corps will likely conduct a crossing or breach during conditions of limited visibility, corps Avengers organize to fight accordingly. AMD planners must consider the risk of enemy tube artillery during a crossing or breaching operation. This risk assessment will determine the best AMD assets for the operation.

ADA Scheme of Maneuver

6-64. AMD masses to defend critical crossing/breach sites, while maintaining strict OPSEC. WEAPONS FREE zones (for fixed wing) may be established over the crossing sites to maximize AMD engagements.

EAC AD Support

6-65. DCA fighters engage enemy CAS aircraft beyond their bomb release line. If necessary, EAC ADA provides area HIMAD coverage of corps rear.

[RDL](#)[Table of](#)[Document](#)[Download](#)[Homepage](#) [Contents](#) [Information](#) [Instructions](#)

Chapter 7

EAC Air and Missile Defense Operations

The purpose of this chapter is to describe the employment of the EAC ADA brigade in combat operations. EAC ADA brigade combat operations doctrine supports Army operations in protection of the force. Freedom to maneuver, without interference from enemy air and missile attack, and protection from reconnaissance, surveillance, and target acquisition is the objective of the U.S. Army AMD.

EAC OPERATIONS

7-1. The EAC ADA brigade must be flexible to meet the demands for AMD in a wide range of environments. Those environments range from peace to conflict and finally war. During time of peace, the EAC ADA brigade must train to meet the operational challenges of the mission in all environments of war and other military operations.

THEATER PLANNING

7-2. The EAC ADA brigade commander begins his AMD planning by integrating his AMD forces into forces already in the theater. He coordinates his operations with those at the theater level.

Organizing the Joint Force Theater of Operations

7-3. The JFC/Combatant CINC establishes a theater command structure including command/support relationships, and a theater battlefield framework. The JFC/Combatant CINC also develops a joint force strategy and campaign plan. As described in chapter 2, this consists of an operational level concept which arranges a sequence of symmetrical and asymmetrical tactical actions to reduce the enemy's will to fight.

Execution of Service or Component Operations

7-4. Service and component commanders, such as the ARFOR commander and the JFACC, sequence battles and tactical operations to meet the CINC's intent for the theater

campaign. This sequencing extends from deployment operations into the theater through all phases of the campaign.

Organization for Sustainment

7-5. The Army operational-level commander establishes support and coordinating relationships with the host nation and with allied forces. Service commanders establish a theater sustaining base to sustain their forces in support of the theater campaign plan. The Army commander provides RSOI and protection of deploying forces as they arrive in theater. This may be accomplished by a tactical or operational headquarters such as a field army, or by an Army service component commander (ASCC) for Army forces. The ASCC additionally establishes linkages to joint, multinational, interagency, non-governmental, or United Nations operations.

Operational Protection

7-6. The Army commander conserves his combat power through operational protection means. Centrally planned OPSEC and deception operations protect essential elements of friendly information (EEFI) and conceal key capabilities and dispositions. He implements rear area physical security means, including hardening of key facilities and C² nodes, organizing a rear operations plan which supports the joint rear area (JRA) plan. Operational protection includes AMD of the rear area and key assets. This is accomplished by joint or combined DCA and TMD operations.

OPERATIONAL AIR DEFENSE

7-7. Ground based AMD units execute the bulk of the force protection mission. The EAC ADA brigade is an important component of Army warfighting force structure, and its role differs fundamentally from that of the corps ADA brigade. The primary purpose of EAC ADA operations is to support operational force protection. AMD at the operational level is an integral function of joint and combined DCA operations. The EAC ADA brigade is involved in many theater level functions and may interface directly with the ARFOR/LCC, the JFACC, the JFC and the ASCC. For example, the 11th ADA Brigade may deploy and fight with Third US Army in the USCENTCOM AOR, with missions ranging from ports of debarkation (POD) defense to JF protection. Operational AMD requirements orient EAC AMD operations on the basic capabilities described in the following paragraphs.

Deployability

7-8. Force projection operations are described in chapter 3. The EAC ADA brigade must be capable of rapid strategic and intra-theater deployment to support entry operations and operational maneuver. EAC ADA battalions maintain the training proficiency to deploy by

strategic airlift or sealift. They also must be trained to deploy by road convoy or rail over long distances within a theater of operations. The EAC ADA brigade plans the force tailoring and sequencing of units and capabilities in the deployment planning process. The brigade coordinates to ensure the integration of its elements into the TPFDL. Additionally, it conducts employment planning with the gaining command.

Integration

7-9. The EAC ADA brigade must be well integrated throughout all phases of the theater campaign. Integration is achieved procedurally by integrated planning. In execution, the EAC ADA brigade is integrated through positive and procedural means.

Liaison

7-10. Integration requires the early deployment of LNOs to higher headquarters within the COMMZ or in the employment area of operations. During employment operations, liaison teams may be required at the following locations: adjacent ADA brigade headquarters, CRC, the JFACC AOC, and the JFC and ARFOR CP. The ADA brigade develops a liaison concept of operation and identifies LNO augmentation requirements during the planning process.

C³ Connectivity

7-11. The EAC ADA brigade C³ requirements include receiving a recognized air picture from a CRC equivalent, C² links to higher and subordinate headquarters, and integration with strategic TM warning/intelligence systems. EAC ADA battalions may be widely dispersed within a theater of operations. The EAC ADA brigade must be proficient in establishing connectivity with aerial and ground C² nodes of various services and in some cases with allied national systems. Joint or theater signal assets provide communications to the EAC brigade. The brigade also has an organic signal company to provide limited tactical communications support (FM, MSE).

Operational-Tactical Agility

7-12. As the Army level AMDCOORD, the EAC ADA brigade commander makes AMD priority and mission recommendations to the Army commander. AMD missions at this level may have operational significance by protecting theater level sustaining bases, military or political headquarters, or PODs. Enemy attacks of these assets will be undertaken with operational level air or missile weapons for operational or strategic objectives. The AMDCOORD also assists the Army commander in making AMD and airpower apportionment recommendations to the JFC. Further, the force and engagement operations of the EAC ADA brigade are standard tactical operations that are planned and

executed in much the same manner as corps or divisional AMD operations. Moreover, the EAC AMDCOORD has the same responsibility as his corps, divisional, and maneuver brigade counterparts to vertically integrate and synchronize adjacent AMD operations within his AO.

Theater Missile Defense

7-13. The Patriot system is the only JF weapon capable of engaging TMs in their terminal phase of flight. Corps Patriot units may provide TM defense, but are primarily oriented on defense of a mobile corps against air attack. The threat to the theater rear may be primarily a missile threat if the enemy has TM weapons. If the enemy has nuclear or chemical capability, effective TMD directly supports operations at the operational and strategic level. The first question to be answered, therefore, in planning the employment of the EAC ADA brigade is, 'what is the enemy TM threat?' The answer to this question largely determines whether the EAC ADA brigade will be tasked under the JFACC or will integrate into TMD operations.

THE EAC ADA BRIGADE THREAT

7-14. The air and missile threat to the EAC ADA brigade AO varies by area in the theater rear. In addition, the threat may change over time.

AIR INTERDICTION

7-15. Enemy airpower will be used against high value targets throughout the depth of the theater. Friendly forces are most vulnerable to air attack where forces and capabilities are concentrated. During entry operations, enemy air will be a particular threat to PODs. Airpower may be used against these before sufficient DCA firepower can be massed in the AO. As entry operations transition to employment operations, enemy air may continue to be used against operational level targets in the rear.

MISSILE ATTACK

7-16. TMs and CMs are particularly suited as operational level weapons. The destruction capability of a conventional TM is very limited compared to the combat load of a typical ground attack aircraft. But an aircraft must run the gauntlet of AMD. It is also affected by weather and limited visibility. A TM or CM can be launched from the depth of the enemy's strategic rear area. It is unaffected by weather and, except for the Patriot system, invulnerable to DCA assets. TMs and CMs can strike with great accuracy to destroy high payoff targets in the theater rear. Missile strikes are particularly threatening during entry operations, especially when theater forces are not ready to fight and political will is still formative.

THE EAC ADA BRIGADE CONCEPT OF OPERATION

7-17. The EAC ADA brigade is required to perform many different operations. Its mission and weapons systems are described in the following paragraphs.

THE EAC ADA BRIGADE MISSION

7-18. The EAC brigade executes rapid strategic deployment to a theater of operations when ordered. It provides air/missile defense and counter-RISTA protection of entry operations and subsequent defense in support of Army or joint force AMD priorities.

EAC ADA BRIGADE WEAPONS

7-19. The task organization of the EAC ADA brigade is more dependent on the situation than the corps ADA brigade. The EAC ADA brigade includes a mix of SHORAD and HIMAD battalions and in the future, a THAAD battery.

HIMAD Operational Concept

7-20. Complete coverage of the theater rear is beyond the capability of an EAC ADA brigade. On the other hand, the EAC ADA brigade has the only weapons in the theater rear capable of engaging TMs. Theater assets are typically larger and less mobile than corps and divisional assets. If additional ADA brigades are not available, the brigade employs HIMAD in defense of critical theater assets and relies on the AADC to defend the theater rear with joint DCA weapons. Because of its unique TM defense capability, TMD operations are the main effort for EAC HIMAD operations.

SHORAD Operational Concept

7-21. The requirement for EAC SHORAD battalions stems from two facts. First, no joint theater AMD plan can guarantee that an enemy air force will be destroyed and stopped from penetrating to the theater rear. Second, there will be times when the theater battlefield framework is nonlinear. Theater assets are vulnerable to sustained enemy air attack. Examples include PODs during entry operations. EAC Patriot defenses will be anchored on TMD priorities and might not cover all LOCs. EAC SHORAD is deployed earlier than HIMAD and in much greater numbers to provide initial AMD of a lodgment. It is effective against attack helicopters and has no electronic signature. As entry operations mature and transition toward employment operations, EAC SHORAD may protect critical LOCs forward to the corps rear. It may supplement HIMAD coverage and provide final protective AMD fires in defense of critical assets.

OPERATIONAL AND TACTICAL ADA SUPPORT

7-22. The EAC ADA brigade operations may directly support the joint DCA campaign, defend operational level fire and maneuver, reinforce tactical level AMD operations, or provide TMD of critical assets and activities. The EAC ADA planner applies the same planning methodology as do his corps and divisional counterparts in developing the AMD plan. The more static nature of EAC operations means that mobility as a passive AD means is not normally an option. Therefore, AMD mobility is less important to the EAC AMD planner than a strong AMD defense design.

JOINT DEFENSE COUNTER AIR SUPPORT

7-23. DCA operations are described in chapter 2. The objective of DCA operations in the theater rear is to neutralize enemy air interdiction and to protect friendly forces, bases and LOCs. Many of the principals of mobile or area defense described in chapter 6 apply also to DCA operations in the air environment. Based on intelligence preparation of the theater air battlefield, the AADC recommends apportionment of airpower to DCA and joint support relationships for ground based AMD. Sophisticated intelligence and warning systems alert the AADC to the location and probable targets of an incoming air attack. Electronic countermeasures strip away enemy electronic concealment and deception. Mobile DCA air assets function as an aerial covering force to engage and break up attacking aircraft formations. Ground based AMD from the divisional main battle area back to the theater rear provide limited area defense and point defense of probable enemy air targets. Additionally, AMD deployed along avenues of approach drives enemy aircraft up into HIMAD and fighter engagement zones.

Key Events

7-24. Key events of DCA operations encompass the initial detection of enemy air attack and air to air DCA. They also include DCA electronic warfare final protective fires by ground based AMD.

AD Priorities

7-25. Theater AD priorities are highly situation dependent, but normally consist of assets and activities of operational significance to the Army or joint force commander. As mentioned earlier, these would almost certainly include PODs during entry operations. Operational level C² headquarters might also be AD priorities as well as geopolitical assets.

ADA Missions

7-26. The AADC has functional coordinating authority over all DCA forces. If apportioned DCA airpower is insufficient, the JFC may supplement it with OPCON ADA. In this case, the EAC ADA brigade will receive missions from the AADC, while the ASCC retains responsibility for support of the brigade. The AADC may segment the air area of operations and assign primary responsibility for active DCA to HIMAD, SHORAD, or fighters within designated WEZs. EAC ADA operates within an established MEZ, which is bordered by adjacent MEZs or FEZs. AADC missions to EAC ADA may be initially framed in terms of an asset or a defined volume of airspace. In NATO, for example, the RAADC may issue a "coverage mission order" to an EAC ADA unit. The ADA brigade develops a defense design to meet the area or asset defense requirements. It redefines the dimensions of the defended area. If necessary, this is done in coordination with the AADC.

Defense Design Considerations

7-27. Defense design in support of DCA operations begins with analysis of the threat to the defended asset or MEZ. Threat attack options in terms of weapons systems and avenues of approach determine the ADA brigade allocation and disposition of ADA fire units as well as the shape of the brigade defense design. For HIMAD defenses, adjacent AMD to the flanks and rear of Patriot coverage is essential in cases where less than a battalion is involved. Defense design options are further explained in [Appendix A](#). At brigade level, defense design must also consider airspace restrictions, such as base defense zones or low level transit routes. The EAC AMDCOORD coordinates airspace with the ARFOR and ACA to minimize the impact on AMD operations. The brigade should also provide guidance on emissions control in support of the Army commander's concept for OPSEC and deception. EAC battalion defense design positions fire units using ADA employment guidelines and weapon system characteristics. In cases where the unit may receive different types of missile munitions, ADA battalions adjust defense design and the distribution of ammunition to position more capable ammunition where it is most needed.

THEATER MISSILE DEFENSE

7-28. TMD is inherently a joint mission. Therefore, joint force components, supporting combatant commanders, and multinational force TMD capabilities must be integrated. They have the common objective of neutralizing or destroying the enemy's TM capability. TMD must be integrated and support the JFC's overall concept of operations and campaign objectives.

Key Events

7-29. Key events in TMD include deterrence of aggression and protection of US, allied, and coalition forces, critical assets, and areas of vital interest or political importance from attack by TMs. TMD encompasses the detection and targeting of enemy TM systems. It

allows the JFC the freedom to conduct joint operations without undue interference from enemy TM attacks.

TMD Priorities

7-30. TMD priorities must address critical data/voice links. These are required for an integrated and coordinated operation. Further priorities are the detection, warning, and reporting of TM launches; and the coordination and integration of multifaceted responses to the TM attack. TMD priorities seek to reduce the probability of damage and or minimize the extent of damage caused by a TM attack.

ADA Missions

7-31. THAAD and Patriot systems, possibly augmented by Aegis cruisers or destroyers, provide a two-tier defense for selected high-value theater assets, military and geopolitical. The two tiers provide near leak-proof defense of high-value assets, deny the enemy a preferred attack option, and support the theater and corps campaigns and battles. THAAD will provide the upper tier defense against medium- and short-range ballistic missiles. Patriot and Aegis cruisers/destroyers, if available, will provide the lower tier defense against short-range ballistic missiles, cruise missiles, and air-to-surface missiles. Patriot also engages the ABT that penetrates the joint defenses.

TACTICAL ADA REINFORCEMENT

7-32. Reinforcement of corps ADA is always a possible mission for the EAC ADA brigade and may frequently be an explicit contingency. Since corps are normally assigned ADA brigades, reinforcement may be in the form of a support relationship established between a subordinate EAC battalion and the corps ADA brigade.

AD Priorities

7-33. AD priority during maneuver operations of a corps could be POL stocks and resupply locations. During defensive operations, AD priority could be corps ammunition points.

ADA Missions

7-34. EAC reinforcement of corps ADA focuses on the corps rear area and LOCs forward to division rear boundaries. These may become extended as the corps maneuvers. After a corps maneuver, assets in the rear may move forward to support a subsequent corps maneuver. In both instances, these assets may be vulnerable to air/missile attack. Depending on the threat, the EAC brigade may be required to commit a battalion of either

SHORAD or HIMAD for reinforcement.

Defense Design Considerations

7-35. The air/missile threat to the corps and theater rear are similar. The difference in the defense design is that corps assets are mobile. If enemy TMs pose operational risks to the rear, a Patriot battalion will provide TM defense of critical assets with ancillary ABT coverage oriented to threat air avenues of approach. Regardless of the command or support relationship, distance will probably preclude the EAC HIMAD unit from receiving an air picture, missile resupply, or maintenance from its parent brigade. A reinforcing HIMAD unit brings its own DS maintenance unit, while the corps ADA brigade coordinates the logistics requirements with a supporting ASG. The corps ADA brigade will also provide an air picture and fire direction to the augmenting EAC HIMAD unit. Likewise, EAC SHORAD must integrate into the corps EW network. EAC ADA units must establish liaison with either the corps ADA brigade or the supported ADA or maneuver unit.

REAR OPERATIONS

7-36. The EAC ADA brigade fights in the theater or corps rear. Its operations are affected by tactical offensive or defensive action in the corps AO only to the extent that these are synchronized with operational fires and enemy interdiction efforts. The principal activities in the rear area are sustainment, force protection, and command and control. Enemy attacks against the rear are aimed at disrupting one or more of these activities. Therefore, the EAC ADA brigade operates within a potential battlefield that is highly nonlinear and where the enemy includes air as well as ground forces. The EAC ADA brigade may be assigned to organize the ground defenses of several units within a defined base cluster. Bases are formed within the base cluster. [Figure 7-1](#) displays examples of notional bases and base clusters.

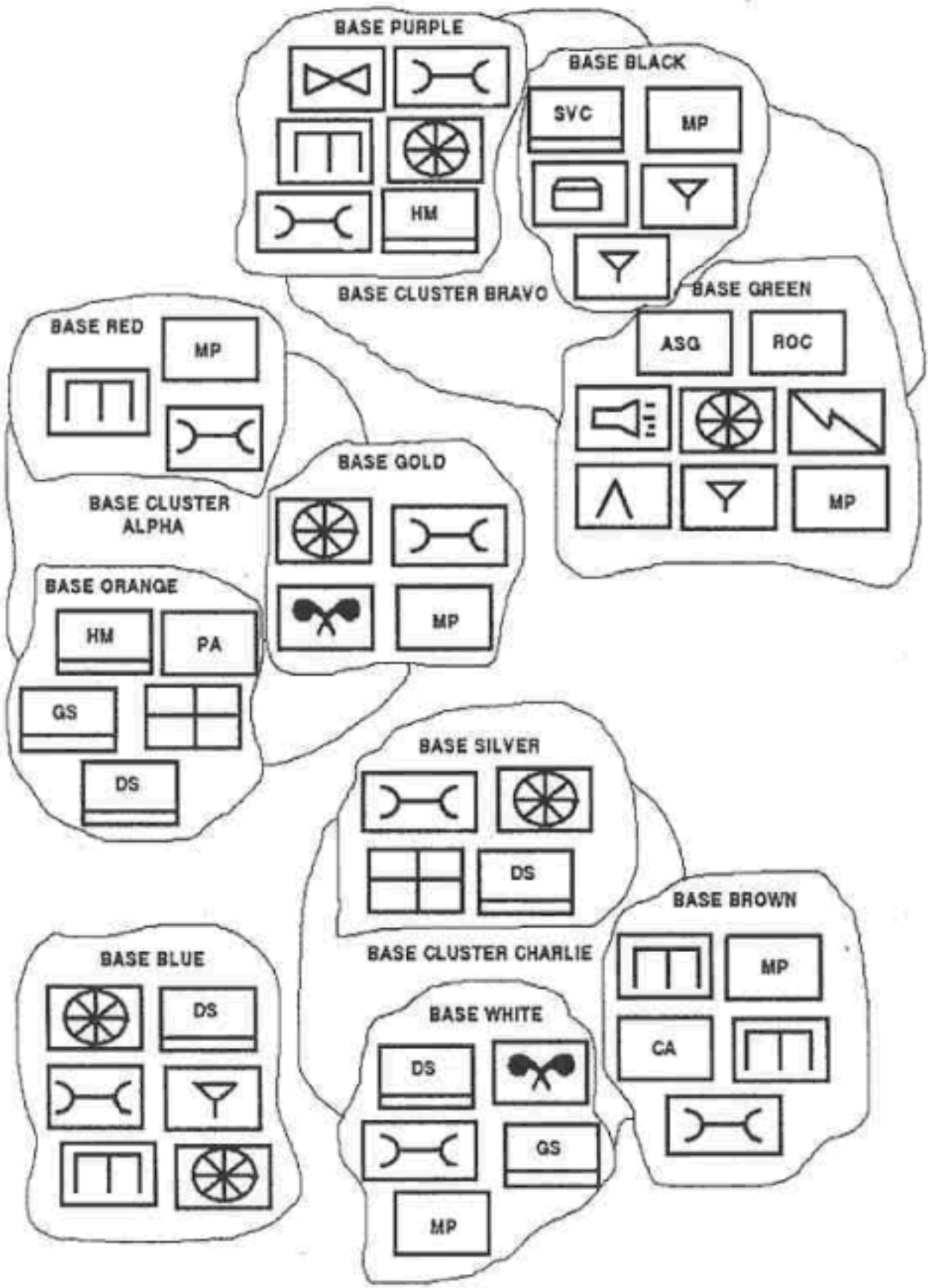

Figure 7-1. Examples of Notional Bases and Base Clusters

7-37. Rear operations consist of activities that assure freedom of maneuver and continuity of operations. Ground threats to the rear area are categorized in three levels of intensity, while rear area defenses focus on four force protection functions.

THREAT LEVELS

7-38. There are three threat levels. Level I contain threats that can be defeated by base or base cluster self-defense measures. Level II contains threats beyond the base or base cluster defensive capability, but which can be defeated by initial response forces. Bases and base clusters are responsible for delaying level II threats until the arrival of response forces. Level III contains threats that target several friendly rear elements as part of a larger, coordinated effort, requiring a tactical combat force to defeat them.

REAR SECURITY TASKS

7-39. This requires not only well-coordinated defense plans, but also good threat intelligence, aggressive local patrolling to intercept the threat, and a highly mobile response force to handle rear area attacks. Positioning of units in the rear should incorporate a threat template so that units do not locate near enemy avenues of approach or drop zones.

COMMAND AND CONTROL OF REAR OPERATIONS

7-40. The JFC normally establishes a joint rear area commander (JRAC) who has coordinating authority to ensure the security of the rear area. The JRAC coordinates requirements with component or service commanders. The ASCC coordinates rear operations for Army forces. He may delegate this function to the senior logistics headquarters, which in turn organizes a rear operations center (ROC) to carry out these functions. Encompassing several tenant units, local defenses are organized around base clusters, established by the ROC. The rear area commander tasks selected commanders to function as base cluster commanders and to organize the defenses of these clusters.

THE EAC ADA BRIGADE ROLE IN REAR OPERATIONS

7-41. If the EAC ADA commander is also a cluster commander, he may establish a separate operations center to organize the rear battle effort within his cluster. This will involve a combination of his own staff and LNOs from other tenant units within the base cluster. The ROC will establish reporting requirements for base clusters and tenant units. Tenant units as well as base cluster commanders must coordinate movements within the rear area to maintain the integrity of rear area defenses. The EAC ADA brigade provides an air defense element to the ROC to assist in planning and alert the force of rear area enemy air insertions.

[RDL](#)[Table of](#)[Document](#)[Download](#)[Homepage](#) [Contents](#) [Information](#) [Instructions](#)

Chapter 8

Sustainment Operations

This chapter addresses the sustainment requirements for the ADA brigade. These requirements must be considered when planning and executing AMD operations. As discussed in Chapter 2, successful AMD operations depends on well planned logistics operations. This demands that AMD force planners and operators at all levels understand integration of AMD systems and their associated sustainment. The dynamic characteristics of each AMD system contribute a warfighting capability to the EAC and corps areas of operation. Each ADA brigade brings with it unit and system sustainment requirements. The location where a system is employed and the manner how the system fights shape these requirements. This chapter implements STANAG 2070.

LOGISTICS FUNDAMENTALS

8-1. Logistic supportability is a prerequisite to all military operations and the quantitative underpinning of the art of war. US national military strategy is one of global force projection, while Army doctrine is a doctrine of fire and maneuver. The sustained mobility of a land force is thus a function not of the mobility of its maneuver forces, but of the supporting logistics system. Therefore, at the strategic level, as well as the operational and tactical levels of war, the logistics system can be greatly challenged.

LOGISTICS PRINCIPLES

8-2. The five sustain imperatives of anticipation, integration, continuity, responsiveness, and improvisation are essential to effective, efficient logistics operations. Foremost among these is anticipation. Logistics planners apply planning factors to the concept of operation to arrive at the concept of support which puts CSS where and when it is needed. Planners also determine where and when the CSS will probably be needed in the future. In other words, logistics lead times frequently require support to be pushed forward in anticipation of requirements. This illustrates the second logistics imperative of integration. There must not be any disconnection between the operations and support plans. Support unit SOPs and administrative norms are secondary to the battlefield requirement of integration.

Logisticians are represented on all tactical unit staffs and are involved at every stage of

mission planning. Direct support logistical units establish physical liaison with their principal supported unit. Effective integration and anticipation result in continuity of support and logistic responsiveness. Logisticians understand the battle rhythm of the supported force. They surge the logistics effort alternatively between moving and fueling the force on the move, as well as fixing, arming, and manning the force in contact. Users of logistics play a vital role in maintaining the responsiveness of the logistics system by maintaining supply discipline and adhering to logistics plans and priorities wherever possible. Where the logistics system falls short of requirements, as can easily happen to units that do not have priority for support, improvisation is an important capability. Commanders must anticipate probable requirements and opportunities for improvisation.

ORGANIZATION FOR SUPPORT

8-3. The following paragraphs detail the organizations that provide the support to the ADA brigade. These organizations may change depending on the situation and mission.

The ADA Brigade

8-4. The ADA brigade is both a user and a provider of logistics within its capability. This requires the brigade logistics staff to coordinate logistics support with external supporting units and to plan execution of logistics support with organic organizational and DS logistics elements. The objective of brigade logistics operations is to assist battalions in executing support functions and to coordinate brigade logistical requirements with external supporting units. The ADA brigade forecasts CSS requirements to the corps support command (COSCOM) or theater support command (TSC) and notifies ASG headquarters of planned ADA unit movements into or out of their AO.

S1

8-5. The S1 has staff responsibility for the manning function as well as some aspects of the sustaining function. The S1 is staffed to man the S1/S4 element of the TOC on a 24 hour basis and to provide brigade level personnel service support to the brigade as a whole. The brigade HHB also has a small personnel service element. Personnel trained in strength management and personnel readiness management assist the S1.

S4

8-6. The brigade S4 has staff responsibility for logistics matters associated with the logistics functions of arming, fueling, fixing, moving, and sustaining the force. To accomplish this, the S4 coordinates closely with the brigade technical maintenance staff, which includes personnel trained in maintenance of the brigade's weapon systems and support equipment. In some cases, the technical maintenance staff may be incorporated

into the S4 staff. The S4 also has food service and supply staff assistants, including a property book officer. The S4 section is staffed to man the brigade TOC S1/S4 element on a 24-hour basis and to effect liaison and coordination with supporting agencies and subordinate units.

ADA Battalions

8-7. ADA battalions are staffed with logistics officers and technicians to accomplish basic logistics functions. In addition to organizational maintenance elements, HIMAD battalions have a DS maintenance company, which provides conventional, missile, and communications electronics (COMMEL) maintenance within its capability. ADA battalions coordinate with ASGs and support battalions for specific support requirements. ADA battalions also coordinate with support battalions to forward supplies received by the supply support activity (SSA) after units have moved to another ASG AO. ADA battery commanders effect direct coordination with designated supply and maintenance points whenever their units move into a new ASG AO.

Logistics Support Commands

8-8. CSS within the corps and theater rear is provided through area support and unit support. Both multifunctional and single function logistics commands are organized to execute CSS for the corps and theater.

Corps Support

8-9. COSCOM employs three or four multifunctional ASGs which provide the full range of CSS. CSS includes supply, transportation, maintenance, and medical and field services. Two ASGs typically position behind the division rear boundaries to support corps troops. A third ASG positions to the rear to provide DS and GS support to the whole corps. Division Support Command (DISCOM) support battalions receive backup supply from a corps GS supply base (GSSB) operated by a rear ASG. ADA brigade units receive common CSS from the nearest ASG. With prior coordination, common CSS can be provided from DISCOM units or from ASG assets collocated within division support areas. The corps Rear CP focuses on conducting rear operations, including sustainment operations, and on developing the corps logistics support plans. The COSCOM CP is the focal point for executing corps support operations.

EAC Support

8-10. In addition to multifunctional CSS commands, such as the TSC, the theater commander organizes other functional commands, such as a medical command, and a personnel command to coordinate specific support functions. The TSC establishes area

support groups behind the corps to support EAC units and units moving through the theater rear. The TSC may also collocate an ASG with the corps main logistics base to support EAC units operating in the corps rear.

PROVIDING ADA FUNCTIONAL LOGISTICS

8-11. Tactical logistics operations are organized around six logistics functions: manning, arming, fueling, fixing, moving the force, and sustaining soldiers and their systems. These logistics functions orient on weapon systems sustainment as a priority.

MANNING THE FORCE

8-12. The objective of this function is to keep weapon systems manned with trained and ready soldiers. It begins in peacetime with good personnel management and unit training programs. In combat, units track personnel strength and identify priority personnel requisitions. The brigade provides consolidated requirements to higher headquarters, which validates them. Personnel commands and replacement units obtain and provide replacements to the unit. The unit conducts reception operations for new replacements.

Strength Management

8-13. Personnel readiness management relies on timely and accurate strength accounting. Strength reporting affects not only tactical employment decisions, but also replacement operations and class I resupply operations. In combat operations, automated systems assist the S1 in strength management actions and maintain visibility of the unit pool of soldiers.

Casualty Management

8-14. The S1 ensures that casualty reports are timely and accurate. Casualty reports are initiated at the lowest level in the chain of command or by any individual having knowledge of the incident. The casualty feeder report, carried by all small unit leaders, is used to report battle and non-battle casualties. Initial reports are usually verbal and are followed up by written reports as soon as possible. They provide the basis for next of kin notification. A witness statement must accompany the casualty feeder report when a soldier is reported missing, MIA, or when soldier remains are not under US control. [Figure 8-1](#) illustrates the casualty information and reporting flow.

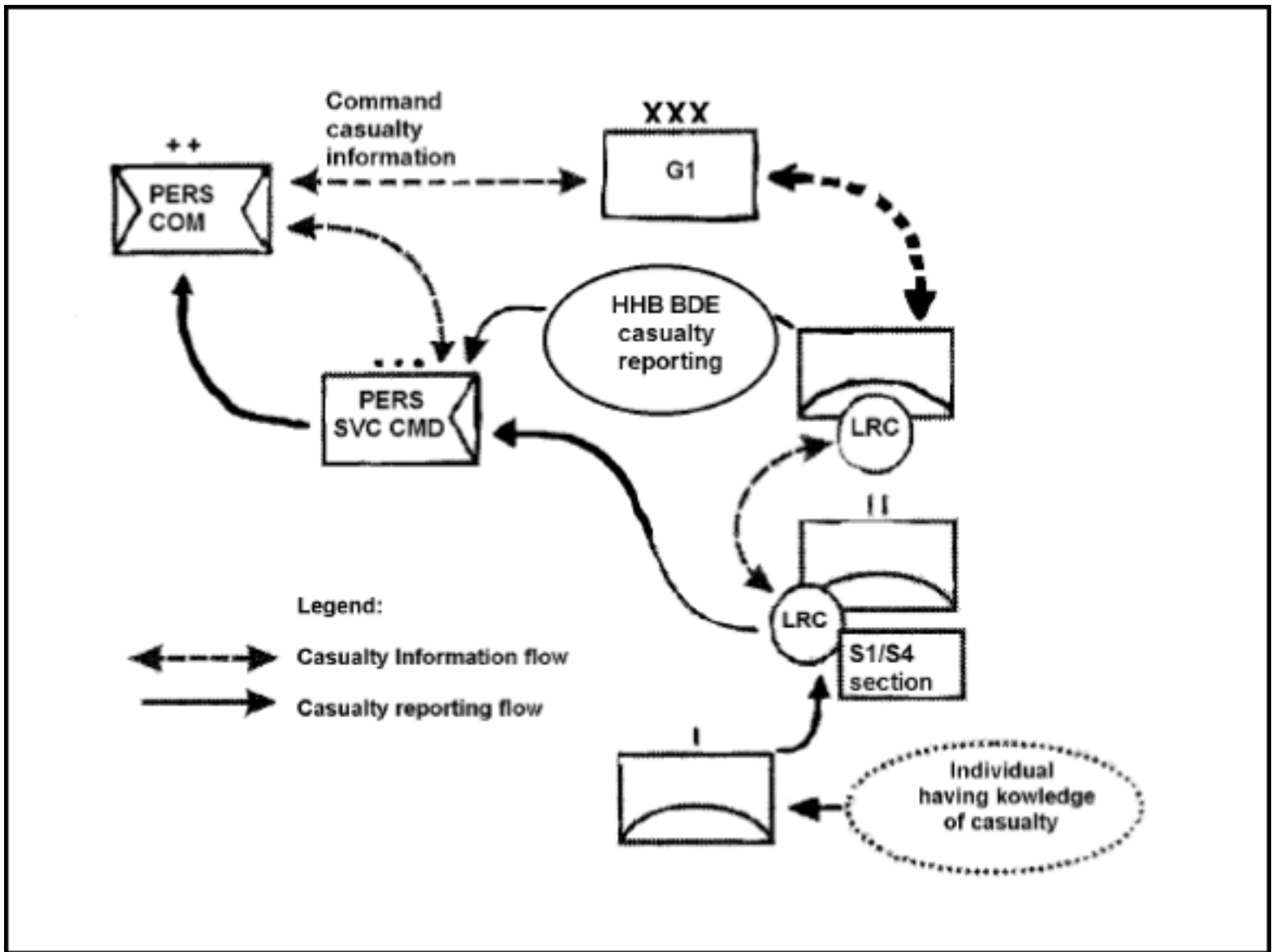

Figure 8-1. Casualty Flow

Replacement Management

8-15. Replacements are provided based on priority requisitions and the unit priority of fill. Replacements are pushed from the COMMZ based on anticipated losses. The ADA brigade manages incoming replacements, providing them to battalions based on operational priorities. Battalion S1s operate a replacement reception point (RRP) to receive and integrate replacement soldiers. Effective RRP operations make the difference between soldiers who arrive at their units ready to fight and soldiers who arrive confused and uncertain. RRP operations are the most important S1 mission and should address all aspects of equipping and preparing new soldiers for combat operations, including orientation to battalion policies and the unit mission; issue of individual equipment and weapons; and introduction to key battalion leaders. ADA batteries also take deliberate steps to equip and train soldiers before they are committed to combat operations. [Figure 8-](#)

2 illustrates the flow of troop replacement.

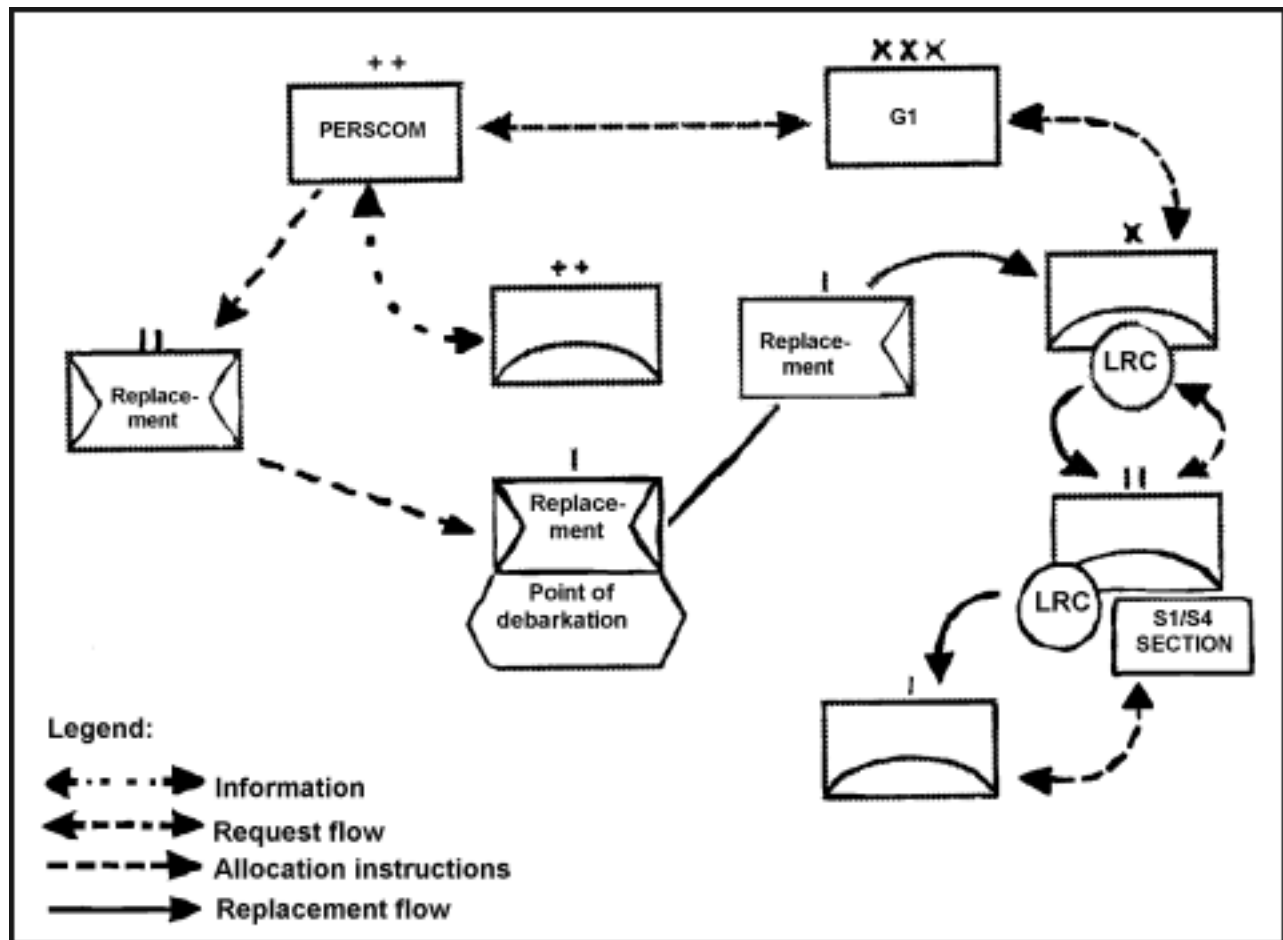

Figure 8-2. Replacement Flow

ARMING THE FORCE

8-16. This function operates to provide the right mix and quantity of ammunition to the right place and at the right time. AMD systems must be rearmed as close to their fighting positions as tactically feasible. During periods of intense combat such as a defense, rearming the force is the most extensive and time-sensitive task of the sustainment system. Ammunition is allocated to units initially in accordance with unit basic load authorizations, established by the theater commander.

Identifying Ammunition Requirements

8-17. Ammunition is allocated in accordance with a command established controlled supply rate (CSR). CSRs are based on priorities for resource fill, established by the higher headquarters, and are expressed in numbers of rounds per launcher or weapon. Patriot ammunition might not have a CSR if the corps is the sole user or if theater transportation is not a constraint. In planning an operation, unit S3s identify their normal daily ammunition

requirements in terms of a required supply rate (RSR). ADA units may have no RSR for small arms ammunition, since their use of individual weapons will be intermittent. An RSR is estimated by answering these questions:

- How many enemy targets will present themselves for engagement by my unit weapons on an average day of combat?
- How many of my weapons, with how many rounds, and what types of rounds will engage these targets?
- When will the RSR significantly increase or decrease?
- RSRs are consolidated and prioritized at each command level. Unit OPORDs identify ammunition on which the CSR differs from the RSR.

GS and DS Ammunition Operations

8-18. In combat, ammunition is pushed from the COMMZ, through theater stocks directly to forward corps and division supply points in accordance with the CSR for these units. Stinger ammunition will be stocked both at division and corps ammunition supply points (ASP). High tonnage Patriot ammunition will normally be stocked in ASPs in the corps rear area. With coordination, HIMAD ammunition can be shipped to division ASPs or even directly to ammunition transfer points in maneuver brigade rear areas, depending on the priority for HIMAD resupply. For EAC brigades, depending on the situation, ammunition shipments may come directly to a battalion or battery ASP. Ammunition packages are prepared in the corps or theater rear area and shipped forward. Division and corps movement control elements track the progress of supply shipments to their destination. Corps ASGs and DISCOMs track the status of inbound supply shipments. Divisions establish checkpoints, called first destination release points (FDRP), at the division rear boundary along MSRs. Ammunition convoys are halted at the FDRP, and final verification of their destination is made in coordination with the DISCOM division ammunition officer. The lead-time required for preparation and delivery of a high tonnage ammunition shipment in the theater rear is approximately 48-72 hours. To coordinate ammunition resupply for brigade units deployed across the corps AO, the corps ADA brigade S4 coordinates with key agencies described in the following paragraphs.

Corps G4

8-19. The corps G4 establishes priorities of support and the CSR in the OPORD. Further it focuses on the managed critical items list.

COSCOM Ammunition Commodity Manager

8-20. This staff source has planning expertise on ammunition capabilities. It develops the ammunition portion of the COSCOM support plan.

COSCOM and ASG Support Operations

8-21. Support operations officers are responsible to plan and execute support operations for their units. At the COSCOM level, the support operation is managed by the materiel management center (MMC). ASGs manage the ASPs within their AO and may coordinate stockage of AMD ammunition and adjustments to scheduled ammunition shipments.

Division Ammunition Officers

8-22. Ammunition operations within division AOs, including ammunition support for corps units, are managed by DAOs. With coordination, the DAO can divert scheduled missile shipments to alternate ASPs to support the HIMAD scheme of maneuver. DAOs also manage inventory levels within all ASPs in the division and may coordinate forward stockage of HIMAD ammunition if necessary.

Unit Level Ammunition Operations

8-23. The ADA brigade deploys with full ammunition UBL. In force projection operations, small arms ammunition is drawn before deployment, while missiles are shipped to the gaining theater. ADA battalions are staffed with small missile resupply sections in the battalion S4 section. Unit level ammunition operations involve three functions: obtaining ammunition from a supply point; distributing it to subordinate units; and reloading AMD launchers. There are several options in executing unit level missile resupply, involving variations on these three functions. Actual unit procedures are an METT-T dependent matter of unit SOP. The next paragraphs describe three common methods of ammunition operations.

Retail Distribution

8-24. The battalion manages a small ammunition transfer point. The S4 organizes ammunition supply convoys, using organic and battery haul assets. Ammunition is obtained from a DS level ASP and delivered to the battalion ASP. Units pick up ammunition from the battalion based on their CSR or mission requirements. This method allows the battalion commander to weight the main effort logistically and minimize stocks on the ground at battery level. It reduces the mobility of the battalion trains.

Unit Pickup

8-25. ADA batteries pick up ammunition directly from a DS level ASP in coordination with the battalion S4. Patriot battalions may use assigned guided missile transports or Patriot launchers as ammunition haul assets. This method minimizes ammunition

management requirements at battalion level, but also limits flexibility at unit level. It may not be feasible for units located far from an ASP.

Reload at ASP

8-26. In this method, Patriot battalions preposition guided missile transports at the ASP. Empty launchers or Avenger fire units drive directly to the ASP and reload there. Battalion S4s coordinate with ASPs for supporting request documentation and arrangements. This method conserves scarce Patriot guided missile transports in order to minimize the impact of GMT shortages on a Patriot battery. It also conserves limited Avenger platoon and battery ammunition haul assets. It requires close battalion coordination with platoons and batteries to ensure that reloaded elements can link back up with their units. However, this method extends the time that an Avenger fire unit or Patriot launcher will be unavailable for AMD operations.

FIXING THE FORCE

8-27. Fixing is the function of sustaining materiel and equipment in an operational status, restoring it to serviceable condition and upgrading its functional capabilities through modification. These functions are performed at unit, direct support, general support, and depot level. A key aspect of maintenance is the ability to repair equipment quickly and as close as possible to the point of failure or damage. The operator is the first link in the chain of maintenance followed by unit organizational mechanics. Avenger battery mechanics are trained to perform limited DS repairs. Patriot units have organic DS maintenance companies that perform DS level repairs on missile and conventional equipment.

DS and GS Maintenance Operations

8-28. Equipment is repaired as far forward as possible. Based on maintenance evacuation criteria established by the corps, equipment will be evacuated to a DS or GS maintenance activity in the corps rear area for repair. The COSCOM task organizes its ASGs with low-density missile maintenance and GS units in the corps rear. DS conventional maintenance capability is performed in the forward ASGs. Each ASG operates a SSA to resupply class IX repair parts and priority requisitions in other classes of supply. The authorized stockage list (ASL) of each SSA is also task organized based on the needs of the supported customer units. The corps also establishes guidance for cannibalization of equipment.

ADA Brigade Maintenance Operations

8-29. The brigade headquarters is authorized a technical maintenance staff that provides staff maintenance expertise and performs maintenance management functions. The EAC brigade coordinates Class IX supply with the TAMMC and oversees Class IX cross-

leveling within the brigade. Additionally, the brigade MMC coordinates class IX cross leveling within the brigade and provides staff maintenance assistance to the brigade commander and subordinate maintenance elements. The brigade MMC assists battalion maintenance elements in tracking the status of requisitions through its ability to electronically query a national logistics supply database, the logistics intelligence file (LIF).

ADA Battalion Maintenance Operations

8-30. ADA battalions are staffed with senior weapon system maintenance technicians on the battalion staff and in each battery. Battalion maintenance management may be organized under the staff supervision of the S4 or may be an independent staff element. In addition to managing internal maintenance operations, the ADA battalion maintenance staff coordinates job orders and tracks maintenance actions with external supporting maintenance activities. Automated systems in each organizational and DS maintenance element perform the functions of prescribed load list (PLL) inventory management, parts requisition, and equipment maintenance records management. Many equipment technical manuals are published electronically. A key battalion maintenance effort, therefore, involves sustaining the operational capability of these maintenance management automated systems. DS level automation will normally require regular updating from unit automated maintenance and supply systems. The unit can provide these electronically or by disk copy. The battalion maintenance element manages this effort to ensure that supporting DSUs have the correct information needed to support the battalion. EAC Battalions have organic maintenance companies. The battalion maintenance element oversees the overall maintenance operation.

Unit level Maintenance

8-31. At unit level, organizational maintenance personnel inspect, diagnose, and repair equipment. Maintenance personnel perform these tasks within their capabilities according to applicable maintenance allocation charts.

Maintenance Operations

8-32. During predeployment preparations, units identify shortages of equipment technical publications and cross level or obtain priority fill. Maintenance checks and services are performed to technical manual standards wherever possible. Equipment dispatch procedures are important to ADA units operating over extended distances and should include not only equipment serviceability checks, but also verification that drivers have enough water, rations, basic tools, medical supplies, and individual equipment to sustain if they are delayed or break down. Unit class IX requisitions are initiated either manually or electronically and delivered to the supporting SSA by the unit.

Equipment Status

8-33. Equipment that cannot be repaired IAW the evacuation criteria outlined in the OPORD will be evacuated to the DSU. Battalions are responsible to track DS job orders with DSUs. Battalions notify the brigade S4 of equipment evacuated to GS. The brigade property book officer (PBO) drops this equipment from the property book and requisitions a replacement. ADA units are responsible for recovering their own vehicles. Motor sergeants and wrecker operators must be proficient in recovery techniques outlined in [FM 4-30.31](#).

Battlefield Damage Assessment and Repair

8-34. Technical manuals prescribe optimal procedures and requirements to inspect and repair equipment. On the battlefield, technical manual guidance is still applicable, but nonoperational equipment must sometimes be repaired under degraded conditions without necessary tools or parts. In these instances, unit mechanics must make do with temporary fixes to keep critical equipment in operation. Army doctrine recognizes battlefield damage assessment and repair (BDAR) as a necessary CSS function. [FM 4-30.31](#) provides doctrinal guidance on BDAR requirements. Technical manuals also provide options for temporary repairs. An effective BDAR capability requires both specialized BDAR equipment and trained mechanics. All ADA organizational maintenance activities, including unit communications sections, deploy with a basic BDAR capability.

Weapon System Maintenance

8-35. ADA brigades are organized with DS ordnance companies to provide DS level repairs of assigned HIMAD battalions. These companies provide one-stop maintenance and Class IX support. They are capable of repairing automotive, communications, COMSEC, construction, power generation, small arms, turbine engine, and quartermaster and chemical equipment.

Patriot

8-36. Patriot intermediate support element (ISE) teams will collocate and provide DS to Patriot battalions. GS support will be provided from theater or COMMZ GS elements. The foundation of Patriot organizational maintenance is automated fault isolation systems and replacement of circuit cards containing faults. Unit maintenance technicians use the Patriot weapons control computer and electronic technical manuals to isolate system faults. The Patriot automated logistics system (PALS) allows the battery maintenance element to continually monitor the system and identify faults as they appear.

DS Ordnance Company

8-37. The DS ordnance company can perform metal working functions and repairs of special electronic devices and tactical microwave systems. It is organized to provide up to two maintenance support teams and limited base shop support for Patriot peculiar equipment and limited class IX support for the Stinger weapon system.

Avenger

8-38. Avenger missile maintenance support teams will deploy with corps avenger battalions and provide DS missile maintenance. GS support will be provided by the Rear ASG and from the COMMZ. For Avenger units operating in divisional sectors, DS missile support may be obtained from DISCOM main support battalions with prior coordination. One key item for Avenger maintenance is argon gas, which is unique to the Avenger system. This is a Class III item for resupply. Maintenance elements coordinate for necessary resupply of Argon gas from the COMMZ.

Army Oil Analysis Program

8-39. Army oil analysis program (AOAP) services continue during combat operations IAW [AR 750-1](#) with priority of support usually with aviation units. AOAP sampling may also be performed in conjunction with DS and GS repairs. ADA brigade units deploy with a basic load supply of AOAP materials. Unit level AOAP actions will normally be programmed for rest/reconstitution periods.

Logistics Assistance

8-40. Technical assistance can be provided under the logistics assistance program. Units will plan to request deployment of attached logistics assistance representatives (LAR). LARs are noncombatants, and units are responsible for life support of LARs.

MOVING THE FORCE

8-41. Movement is inherent in all logistics functions as it is in combat and combat support functions. It is the one element that connects sustainment operations with all other battlefield operations. Movement is a major concern of the S3. He must orchestrate the maneuver of his units; all other movement simply supports that maneuver. The movement function goes beyond the physical movement of personnel and materiel. It involves all the elements of moving forces and their logistics requirements. Some of the components of movement are the physical transportation modes, the process of planning and controlling movement, allocating transportation resources, and prioritizing movement. Within the corps, the COSCOM Movement Control Center (MCC) controls transportation through to

the division rear boundaries. Division transportation officers and MCCs perform similar functions within their AOs. Divisions and corps MCCs do not normally use the same scale of maps, nor does the corps MCC routinely maintain visibility of division routes. Therefore, the brigade S4 plays a crucial role in coordinating with both divisional and corps MCCs for the movement of corps ADA brigade units. [Figure 8-3](#) illustrates the corps class IX request and distribution flow. [Figure 8-4](#) illustrates EAC class IX request and distribution flow.

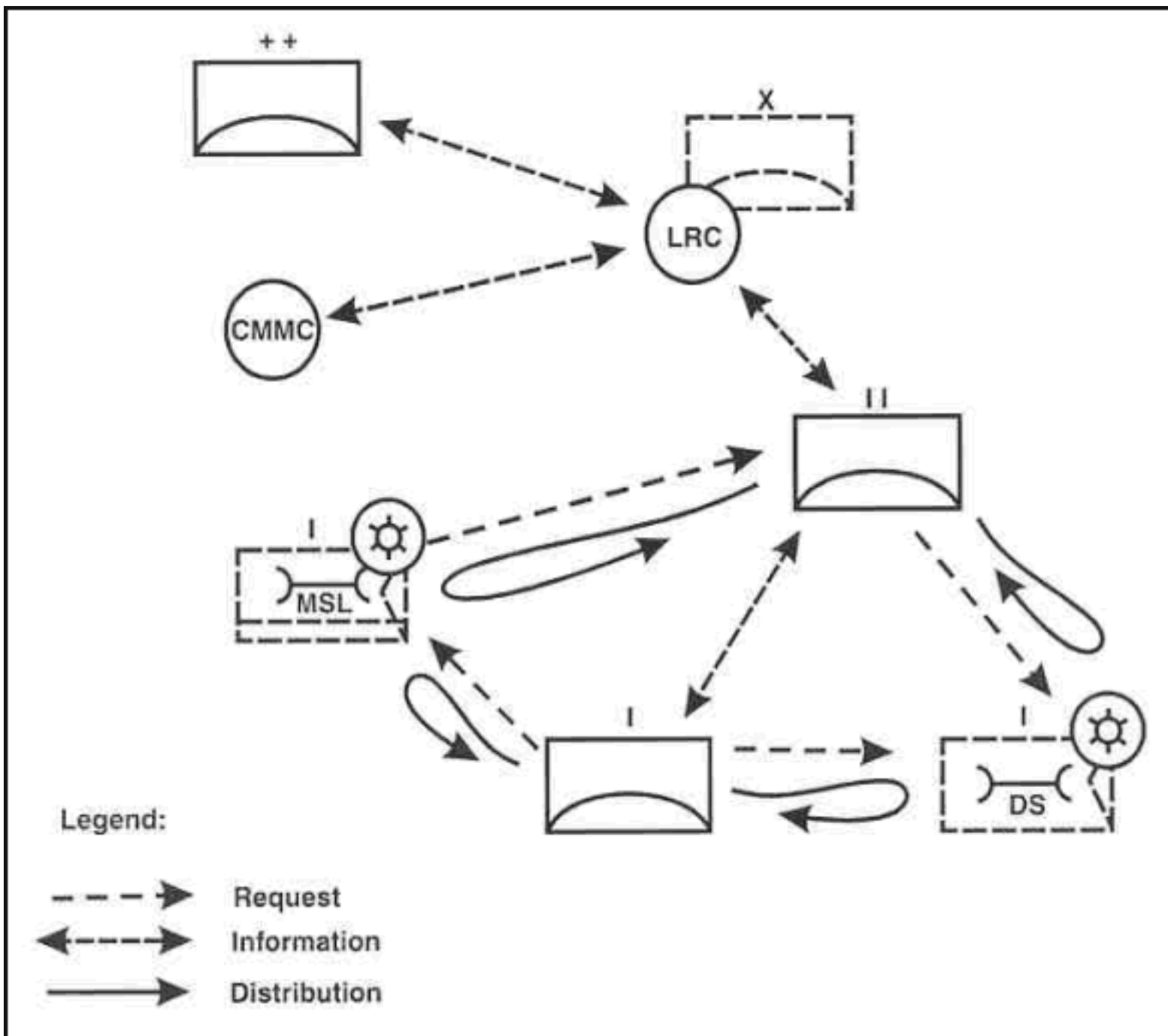

Figure 8-3. Corps Class IX Request and Distribution Flow

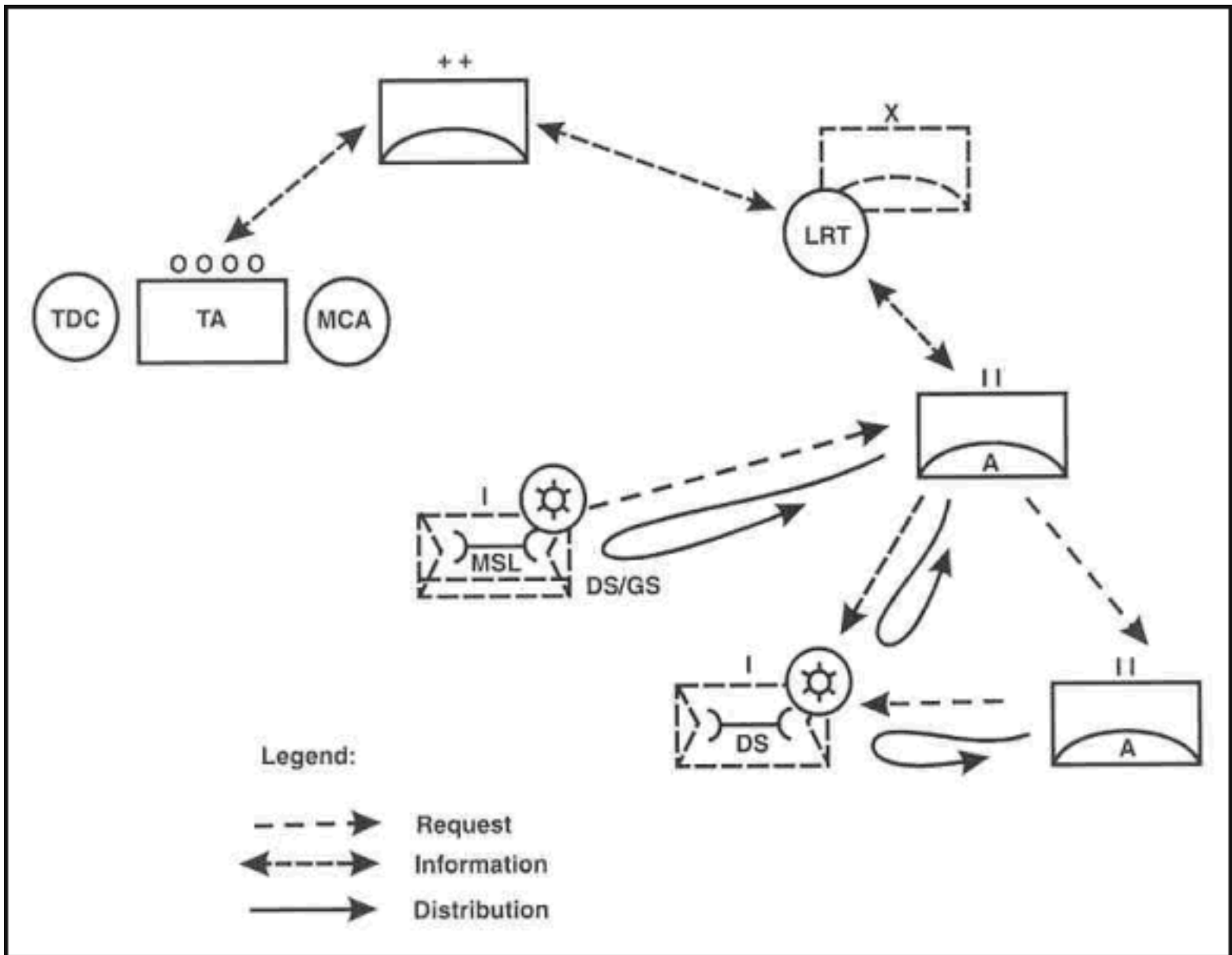

Figure 8-4. EAC Class IX Request and Distribution Flow

FUELING THE FORCE

8-42. Patriot and THAAD units require large amounts of fuel. Refueling sustains both AMD engagement operations and the AMD scheme of maneuver. Unit fuel tankers refuel battery equipment on site. Tankers are refueled at local class III refuel points. ADA units maintain vehicles and full spare fuel cans to be ready to move whenever the tactical situation requires. The corps receives fuel through rail terminals or by road convoy. COSCOM bulk fuel tankers may carry as much as two million gallons of fuel in addition to unit basic loads. The corps establishes GS petroleum, oil, and lubricants (POL) farms, holding up to 5 days of supply in the corps rear area. The brigade S4 forecasts bulk fuel requirements to the COSCOM by ASG. These are updated as the AMD scheme of maneuver transfers ADA units from one ASG area to another.

SUSTAINING SOLDIERS AND THEIR SYSTEMS

8-43. The five elements of this logistics function are personnel, health and field services, quality of life, and GS supply support. This logistics function addresses the soldier as an integral component of a weapon system.

Personnel Services

8-44. Personnel service support functions sustain the morale and welfare of the soldier. At battalion, these include chaplain activities, legal services, public affairs, postal services, and finance support.

Chaplain Activities

8-45. Soldiers performing in extreme conditions of combat have significant spiritual and emotional needs. Army doctrine acknowledges the threat of combat stress and outlines leader tools to counteract it. The unit chaplain plays an important role in this regard. A unit ministry team (UMT) consists of one chaplain and one chaplain assistant. A team is assigned to each ADA battalion and the brigade headquarters. The UMT provides worship services, the administration of sacraments, rites and ordinances, pastoral care, and counseling. The chaplain advises the commander and his staff on matters of religion, morals, morale, ministry in support of battle fatigue, and religious support enhancing soldier morale and unit cohesion. Chaplains also routinely visit unit soldiers in nearby hospitals. The chaplain is responsible for coordinating his programs with the S1 and with the brigade chaplain.

Legal Services

8-46. The ability of the commander to maintain morale, order, and discipline enhances unit combat readiness. Organizational morale is dependent upon the commander's ability to care for the soldier and protect the soldier from unnecessary concern about legal issues. The corps ADA brigade is authorized SJA personnel to provide legal services and to advise the commander not only on UCMJ issues but also on issues concerning the law of war, international law, and ROE. Legal services within the corps are provided on an area basis, locating near the corps Rear CP or the COSCOM headquarters.

Public Affairs

8-47. Public affairs operations function to tell the Army story to news media, informing the public, and maintaining public support for military operations. The ADA brigade may be staffed with a public affairs specialist to advise the commander and subordinate units on matters of soldier and media interest. Corps public affairs staff elements provide similar

functions for the corps staff and subordinate units.

Postal Services

8-48. DS postal platoons receive and separate mail by unit. Battalions pick up mail in conjunction with scheduled logistics runs and distribute internally to their soldiers.

Finance Support

8-49. Mobile pay teams from a corps area finance unit provide finance support. The theater commander may establish limits on how much pay can be disbursed to soldiers. The corps commander may establish a lower amount for his soldiers, based on the tactical situation. Battalions coordinate for soldier pay as required.

Medical Support

8-50. For the purpose of tending casualties, ADA battalions are staffed with combat medics, combat lifesaver trained soldiers, and with basic (level I) surgical capability. Units evacuate wounded soldiers directly to the nearest combat support hospital (CSH) or mobile Army surgical hospital (MASH).

Battalion

8-51. Battalion medical support is planned by the battalion surgeon and S1 and provided by the battalion medical section. Backup support is provided by a supporting medical company assigned to the corps medical brigade. The medical treatment team forms the battalion aid station under the supervision of the battalion surgeon. The aid station provides Level I medical support for the battalion. This level includes triage, initial treatment, stabilization, and medical evacuation. The goal is to get the trauma patient to the initial treatment or advanced trauma management element within 30 minutes of injury. Battalion ambulance teams provide emergency medical treatment for patients en route to higher treatment facilities. Units are responsible for medical evacuation (medevac) of their soldiers to the battalion aid station. The battalion medical section provides dedicated medics with an ambulance to each battery. Units augment the medical section with trained combat lifesavers. Combat lifesavers provide patients with basic medical treatment and stabilization until evacuation.

Corps

8-52. Corps medical companies provide level II care that evaluates patient status and makes determination on further evacuation. A Mobile Army Surgical Hospital (MASH) or Combat Support Hospital (CSH) provides level III care. This includes resuscitation, initial

wound surgery, and postoperative treatment. Casualties whose wounds are life threatening receive surgical care in a hospital close to the clearing station. CSHs are normally located near the division rear boundaries and within each ASG AO. Level IV care is provided by general hospitals located in the theater rear. These hospitals are capable of performing specialized medical and surgical care and reconditioning to expeditiously return casualties to duty.

Field Services

8-53. Field services are logistical soldier sustainment functions. They include food preparation, water purification, bakery, clothing and light textile repair, laundry and bath, airdrop and parachute rigging, and mortuary affairs. They are provided on an area basis by the COSCOM.

Mortuary Affairs

8-54. Proper care of the remains of deceased soldiers is a commander responsibility and a moral obligation. Army doctrine for this is outlined in [FM 4-20.64](#) and STANAG 2070. COSCOM will provide guidance and resources for mortuary affairs operations. Brigade S4 will coordinate with COSCOM for mortuary affairs support. Unit commanders are responsible for tagging, securing, and evacuating the remains of their soldiers. The ADA battalion S4s maintain wartime requisitions for body bags and personal effects tags, to be issued in theater upon deployment. Units are not authorized to bury remains without authorization of the corps Mortuary Affairs Officer. As an exception, chemically contaminated remains may be decontaminated if possible, temporarily interred, and marked as a chemical hazard. All interments are reported to the corps Mortuary Affairs Officer through S4 channels. Units tag and evacuate remains on organic transportation to designated COSCOM or DISCOM collection points. Personal effects are evacuated with remains, while the unit retains organizational clothing and individual equipment (OCIE) and individual weapons.

Other Services

8-55. In the corps and theater rear the ADA brigade coordinates with supporting ASGs for other field services as the tactical situation permits. These include clothing exchange and bath support, laundry, and post exchange support. Field laundries usually provide only rough dry processing service. Clothing exchange facilities are operated as part of the bath facility to provide clean replacement of socks, BDUs and underwear on an individual basis. Textile renovation may be available on an area basis. Batteries deploy with tent repair kits to effect organizational repairs. Soldiers deploy with sewing kits as part of A and B bags. These services are provided on an area basis and can be directly coordinated by battalion S4s and ADA battery commanders. Batteries should anticipate any paperwork

requirements, such as laundry tags, and plan to deploy with the necessary forms and supplies.

Quality of Life

8-56. Military operations are not characterized by unremitting combat, but by a mix of combat operations, tactical pauses, and extended lulls during deployment and redeployment staging operations. Commanders are responsible to program a corresponding mix of readiness and recreation for their soldiers. Soldiers fight better when they are not distracted by problems at home. Units therefore integrate family support planning into deployment planning to ensure that basic family problems can be solved at home station. Batteries deploy with CTA authorized athletic and recreation kits to take advantage of rest and recreation periods. Commanders conduct physical training programs during periods when the unit is not part of combat operations. Commanders keep their soldiers informed and ensure that they receive field services whenever tactically feasible.

ADA BRIGADE SUPPLY OPERATIONS

8-57. The following paragraphs describe the supply operations for the ADA brigade. Mission requirements may determine actual supply operations.

SUPPLY SUPPORT

8-58. The objectives of supply support are to keep weapon systems operational and to sustain the force. Supply operations focus on sustaining both an adequate flow and adequate stocks of supplies. Supply planners coordinate with transportation planners to move supply shipments to supply distribution points. They also coordinate with operations planners to determine supply requirements over time. Multifunctional logistics commands ensure the integration of supply, transportation, and other functions down to battalion level. Supplies are stocked at various points, from GS supply bases to DS supply points to unit basic loads. Tactical agility requires these supply points to be kept continually stocked at a level which sustains, but does not hinder the mobility of forward maneuver units.

UNIT LOADS

8-59. Basic or prescribed loads are unit level "supply points". Units are responsible for replenishing them as necessary to maintain prescribed stockage levels.

Basic Loads

8-60. ADA brigade units typically deploy to war with unit basic loads (UBL) in supply classes I-IV, V, VIII, and IX. Some basic loads will be stocked at DS/GS level or in theater

stocks in peacetime to be drawn/issued on order. Units prepare wartime requisitions for all basic loads not stored at unit level.

Operational/Prescribed Loads

8-61. In addition to basic loads, units maintain and use operational stocks of supplies, including repair parts, POL, and other classes. Units deploy with all operational and prescribed loads of supplies, which can be transported and are maintained to support peacetime operations.

RESUPPLY

8-62. Class I, III, V, VI resupply is scheduled based on planning factors, equipment densities, and mission priorities. Class II, III (POL), IV, VII, and IX resupply is provided based on supply requisitions. Certain items of class II, III (Bulk), IV, V, and VII, as specified in the OPORD, may be command regulated.

Combat Operations

8-63. During combat operations, ADA battalions forecast supply requirements as far in advance as possible. The ADA brigade S4 submits supply forecasts to corps G4. Supplies requisitioned through an SSA are usually shipped to that SSA, even if the customer has departed the SSA's AO. Because of the mobility of corps ADA units, particularly Patriot, battalion S4s coordinate with SSAs to pick up supplies that arrive after a unit has left the SSA's AO. Supply support from host nation agencies or local civilians is accomplished through field ordering procedures normally established and closely regulated at corps level and above.

Coordination

8-64. ADA batteries are responsible for coordinating directly with supply points and for picking up supplies. If supplies are received by aerial delivery, units may be responsible for evacuating the slings, cargo nets, and other associated material to the nearest lift aviation unit.

PREDEPLOYMENT SUPPLY PLANNING CONSIDERATIONS

8-65. ADA brigade elements may deploy and be employed early in a lodgment scenario before a mature logistics system is in place. Moreover, war plans and supporting logistics plans normally assume that units arrive in theater able to sustain for at least two weeks without resupply, apart from rations and POL. The ADA brigade must not only maintain supply discipline and prescribed load stockage levels in peacetime, but be able to rapidly

identify and prioritize shortages in all classes of supply upon alert.

Supply Data

8-66. Deployed unit supply requests will be submitted with an operational project code, a force activity/urgency of need designator (FAD/UND), and a unit identification code (UIC) that are all different from home station supply codes. The ADA brigade S4 coordinates these early in predeployment planning with the appropriate headquarters. Alerted ADA battalion S4s promptly take action to ascertain the status of all supply requisitions. This is done with the assistance of SSAs and by direct queries to the national LIF. When directed, batteries begin using the new supply data in requisitioning supplies, updating existing requisitions if necessary.

Ammunition

8-67. AMD missile munitions will normally not accompany strategically deploying units, but will be shipped to meet them in theater. Army Materiel Command will coordinate this. The small arms ammunition UBL will be issued by the supporting installation or similar agency and will be transported by the unit.

Rations

8-68. Depending on the deployment scenario, the unit may have to bring rations additional to the UBL as "to accompany troops" (TAT) stocks to be consumed during the deployment into theater or to staging bases.

Tools and Basic Issue Items

8-69. Every ADA battery will have some basic issue items (BII) or tool shortages that should be on order and reflected in unit shortage annexes. Alerted battery commanders and battalion S4s identify shortages which affect weapon systems, command and control, and soldier/unit sustainment; and take action to fill them through cross-leveling, upgraded supply requisition priorities, or operational command priorities. Examples could include critical test equipment, individual weapon ammunition magazines and cleaning equipment, or vehicle operator tools.

Miscellaneous Sustaining Supplies

8-70. The tactical logistics system is structured primarily to sustain weapons systems and C². All other supply requirements are secondary. ADA brigade and battalion supply planners maintain sustaining basic loads and CTA authorized equipment to sustain for up to thirty days of operations. Possible examples include tentage with BII or component

spares, spare camouflage repair kits, barber kits, and field shower equipment. Battalion supply planning should identify required quantities of batteries for all equipment that uses batteries, and outline procedures to stock or obtain these upon alert. SB 11-20 provides basic planning factors for batteries. ADA battalions may deploy with a limited operational stock of OCIE to replace shortages. Battery supply elements also plan sustaining stocks of administrative supplies. Examples include supplies for unit computers and forms such as laundry tags and hand receipts used in battery supply operations.

End Items

8-71. DA units may have shortages of MTOE authorized equipment. The brigade S4 maintains a prioritized list of MTOE shortages in coordination with the S3 and submits these for fill upon alert. Additionally, the S3 identifies any force modernization equipment pending fielding which will be required for employment operations. Supporting installations and Army Materiel Command coordinate fill of priority shortages.

Climatic Zone Considerations

8-72. The climatic zones of applicable war plans affect the MTOE and CTA equipment authorizations of ADA units. The factors of terrain and weather may require additional quantities or lines of repair parts; extra water haul capability; or different soldier uniforms, camouflage and tentage. If the unit is ordered to deploy to a different climatic zone, the brigade S4 must rapidly determine any additional supply requirements and initiate supply requisitions.

Deployment-Related Supplies

8-73. In addition to supplies required for employment, there are significant supply requirements associated with preparing unit equipment and soldiers for deployment. Soldier property and nondeploying unit equipment may have to be boxed and banded for storage. Accompanying supplies may have to be boxed or wrapped to protect it in transit. Unit secondary loads must be blocked and braced. Containers, vehicles, and sensitive equipment must be locked. Garrison installation commands normally establish policies on which deployment related supplies are to be stocked by the installation or ordered as needed. Battalions identify items for unit stockage and additional supplies to be requisitioned upon alert.

BATTLEFIELD SUPPLY SUSTAINMENT

8-74. Using supply planning factors and command priorities, unit, DS and GS supply stockage levels are prescribed in terms of days of supply (DOS). Supplies are either transported to units (unit distribution) or picked up by units at designated supply points

(supply point distribution).

Class I - Subsistence

8-75. Units maintain a UBL of MREs as prescribed in the force OPORD. DS supply points maintain additional days of supply (DOS) in the ASGs. DOS is three meals per day. "A" rations will be provided as available according to an established menu. Class I resupply is provided on an area basis by ASGs and DISCOM elements using supply point distribution. ADA batteries maintain a class I UBL and provide food service to assigned and attached soldiers. Plans to support soldiers deployed to remote sites or moving to new locations are also provided. Battery trucks not traveling in convoy should normally carry one DOS per passenger and at least five gallons of water.

Water

8-76. ADA batteries are equipped by MTOE to carry about one DOS of water. A nonoperational water trailer may have an immediate impact on the combat capability of a battery. Organizational maintenance elements therefore carry spare repair parts for the water trailer and commanders maintain sufficient quantities of CTA authorized water cans to supplement the water trailer. The ADA brigade identifies potable water sources for units within its AO. These are normally collocated with a class I supply point. Batteries maintain a capability to chlorinate nonpotable water and unit medical personnel routinely test water for potability.

Class II - General Supplies

8-77. Battalion S4s deploy with component lists, operator technical manuals authorizing BII, and components of end items (COEI) for all battalion deployed equipment. These are used to obtain NSN information for class II durable and nonexpendable requisitions. Units deploy with required quantities of these class II items:

- Administrative supplies, including forms, office supplies, and housekeeping supplies
- OCIE and uniform/personal demand items
- Individual chemical equipment (ICE) packs, as required
- Tentage, tool sets, and class II expendable components
- CTA-authorized athletic and recreation kits
- CTA-authorized field sanitation kits, field latrines, and field shower equipment (If peacetime stockage is not required, units maintain wartime requisitions prepared for submission of order)
- Batteries for all equipment that require batteries

Class III – Petroleum, Oil, and Lubricants

8-78. Units deploy from assembly areas with a UBL of packaged POL and a full basic load of fuel. All trucks, generators, fuel cans, and tankers are topped off. Unit trucks are refueled at the unit fuel point or a local DS refuel point. Units coordinate bulk fuel resupply for tankers with nearest ASG wholesale fuel point.

Class IV - Barrier Material

8-79. Units draw required class IV barrier material upon arrival in theater and subsequently from a supporting supply point. Some of the unit class IV requirements are triple strand concertina wire with pickets, lumber, and sandbags.

Class V - Ammunition

8-80. A portion of the small arms basic load is distributed to soldiers with the remainder transported by the unit supply section. Units obtain resupply of small arms ammunition from nearest Class V supply point.

Class VI - Personal demand items

8-81. Class VI sundry packs, containing various personal demand items, may be made available after the situation permits. If available, they are issued in bulk from the field ration break point or individually at field shower points.

Class VII - Major End Items

8-82. Certain critical class VII items are command regulated and supplied based on unit priority and combat loss reports. The ADA brigade PBO will requisition all other class VII items based on reported battle losses. Hand receipt accountability of class VII below the PBO level may be waived by the Secretary of the Army. Battalion S4s requisition required BII/COEI from SSAs to fill shortages accompanying class VII battle losses. If approved for issue, the COSCOM or supporting MMC will issue a materiel release order (MRO), releasing the required item for delivery or pick up by the unit.

Operational Ready Float

8-83. COSCOM and TSC) will maintain selected items of equipment as operational ready float (ORF). ADA ORF will be issued to keep an ADA fire unit from becoming combat nonoperational. Corps Controlled ORF will be issued as approved by the G4. The G4 needs to ensure that the ORF is pushed to a forward logistics point.

Weapons System Replacement Operations

8-84. For selected high density weapon systems, the corps or theater command may operate weapons system replacement operations (WSRO) points where weapon crews are trained on available ORF or class VII weapon systems and then sent as a trained and equipped package to designated units. Avenger systems and MANPADS might be replaced by WSRO. In the corps, the corps commander or a designated representative is the release authority for WSRO. COSCOM establishes and operates the corps WSRO site in coordination with the corps G3 and AG. The corps AG establishes a personnel-processing point for crews designated for WSRO and coordinates personnel fill of WSRO crews.

Class VIII - Medical

8-85. Units maintain class VIII supply. Unit vehicles are equipped with first aid kits. Squads or section first aid kits can be stocked as necessary. Unit combat lifesavers carry combat lifesaver bags with their individual equipment. Unit medics, ambulances, and surgical facilities also maintain medical supplies. Class VIII resupply is coordinated through medical supply facilities, normally collocated with combat support hospitals.

Class IX - Repair Parts

8-86. Units should deploy with 100% fill of PLL and request resupply through a supporting DSU. Battalions cross level class IX internally and conduct controlled exchange of repair parts from nonoperational equipment as necessary. Units as authorized by its higher headquarters perform cannibalization of nonreparable equipment. Cannibalization is not a logistically sound option. It is used only when the required parts cannot be procured in time. Cannibalization must make the equipment combat operable and must not leave an economically repairable item noneconomically repairable.

Class X - Material to Support Nonmilitary Programs

8-87. Class X supplies may be required in conjunction with support and stability operations. Examples of these are agricultural and economic development. Class X supplies are coordinated through supporting COSCOM or host nation agencies. Unit field ordering officers may procure class X supplies as authorized in the OPOD.

[RDL](#)[Table of](#)[Document](#)[Download](#)[Homepage](#) [Contents](#) [Information](#) [Instructions](#)

Chapter 9

Stability Operations and Support Operations

This chapter discusses the Army's role in stability operations and support operations and how ADA may support those operations. The Army performs important roles in these types of operations. The prime focus of our Army is warfighting, that is the use of force, yet its role in stability and support operations is critical. Use of Army forces in activities conducted during periods of peace helps keep the day-to-day tensions between nations below the threshold of conflict. Typical peacetime operations include nation assistance, security and advisory assistance, counterdrug efforts, antiterrorism measures, arms control, support to domestic civil authority, and peacekeeping operations.

THE ENVIRONMENT

9-1. The role of the US Army in stability and support operations is not new. From its beginning, the Army has performed many missions that do not require direct combat. These missions included protecting our citizens as the country's border expanded; building roads, bridges, and canals; and assisting nations abroad. Whether the mission is peacekeeping, nation assistance, civil disturbance control, support for insurgency and counterinsurgency, or noncombatant evacuation operations (NEO), situations of complexity and sensitivity are likely to be present. The solutions to the situations may not be present or may not be in the interest of the long-term objectives. Army leaders may find themselves facing difficult problems that require new thinking and actions.

9-2. A major consideration in these operations is the need to focus clearly on sustaining the legitimacy of the operation and the host government. Legitimacy is the willing acceptance of the right of a government to govern or a group or agency to make and enforce decisions. It is neither tangible nor easy to quantify. Legitimacy derives from the perception that authority is both genuine and effective, and employs appropriate agencies for reasonable purposes. No group or force can create it, but can encourage and sustain it by their actions. Legitimacy is the central concern of all parties directly involved in a conflict. If US military forces solve an immediate problem within a nation or a region, but in so doing detract from the legitimacy of the host government, they will have defeated their own purpose. Stability and support operations are accomplished in the environments of peace

and conflict. These activities are also conducted immediately following the cessation of hostilities. Although the nation initiates many of these activities in peace, they extend into the environments of conflict and war.

9-3. Peacetime activities include those Army actions that support a CINC's forward-presence operations and, usually as part of an interagency effort, the US Ambassador's country plan. They promote regional stability and peace, retain US influence and access abroad, and defuse crisis. The conceptual framework of peacetime activity reflects a proactive Army dimension in support of a crucial element of our national military strategy. It employs Army capabilities in activities short of war in the causes of instability, thus minimizing the need for combat operations to protect vital national interests. Many of these operations will likely begin with a predominance of military control and influence.

ORGANIZATIONAL STRUCTURE

9-4. The commander-in-chief structures the activity forces to best accomplish the mission. The theater structure is task organized to accomplish the mission. It begins with the National Command Authorities (NCA) under the leadership of the President. It is executed through the various military departments. It creates a defined command, either a combatant command or a joint task force. The defined command integrates the services or forces into an organized structure to accomplish the mission. The theater structure is concerned with war, stability and support operations, and in peacetime requirements. This structure is depicted in [Figure 9-1](#).

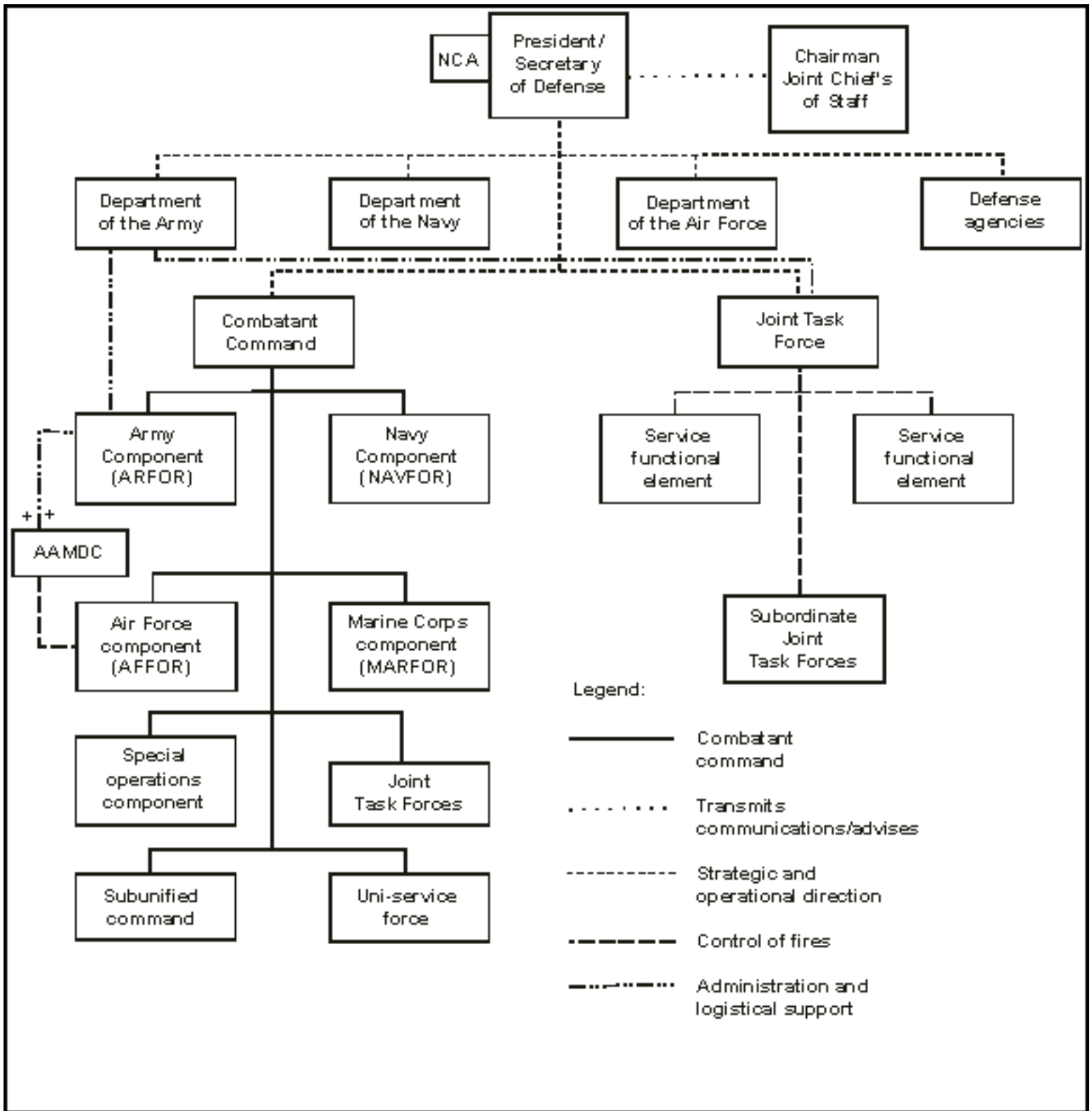

Figure 9-1. Joint Force Relationships

AREA OF OPERATIONS

9-5. The structure of an area of operations is focused on the type of support and stability operation that is given a mission. There are three structures:

- joint operations area
- joint zone
- joint special operations area

CHARACTERISTICS OF STABILITY OPERATIONS

9-6. Army forces conduct stability operations in a dynamic environment. Stability operations are normally nonlinear and often noncontiguous. Army forces conduct operations along logical lines of operation, but not necessarily with geographic reference to one another. Stability operations are often time and manpower intensive. Commanders analyze each mission and adapt the operational framework, elements of operational design, and factors of METT-TC to fit the situation. Commanders designate the decisive, shaping and sustaining operations necessary for success. However, determining the military actions necessary to achieve the desired political end state can be more challenging than in situations requiring offensive and defensive operations; achieving the end state may be just as difficult.

9-7. Stability operations often require commanders to understand and use METT-TC differently. Commanders constantly reassess the situation and the application and interrelation of each METT-TC factor. The "enemy," for example, may be a set of ambiguous threats and potential adversaries. Even the mission may change as the situation becomes less or more stable. The mission can be as simple as conducting a briefing to host nation forces in a military-to military-exchange, or as difficult as conducting combat operations to accomplish a peace enforcement mission. Stability may be threatened for a number of reasons, and an enemy may be difficult to define or isolate. Depending upon the progress of stability, the complexity of the mission may change quickly.

9-8. Different factors may be important when analyzing the terrain and the troops and support available in stability operations. What constitutes key terrain may be based more on political and social considerations than physical features of the landscape. The troops assigned or available to a commander could include nontraditional assets such as host nation police units, contracted interpreters and laborers, or multinational forces. The level of integration and cohesion of a force composed of diverse assets is a key consideration for mission success.

9-9. Time considerations normally are substantially different in stability operations. The goals of a stability operation may not be achievable in the short term. Success often requires perseverance, a long-term commitment to solving the real problem. The achievement of these goals may take years. Conversely, daily operations may require rapid responses to changing conditions based on unanticipated localized conflict among competing groups. Civil considerations are especially critical in stability operations. The civil population as well as the host nation government, nongovernmental organizations

(NGOs), and international organizations have great impact on achieving stability.

9-10. Stability operations are inherently complex and place greater demands at the small unit level. Small unit leaders are required to develop interpersonal skills such as cultural awareness, negotiating techniques and critical language phrases while maintaining warfighting skills. They must also remain calm and exercise good judgment when under considerable pressure. Capable, trained, disciplined, high-quality leaders, soldiers, and teams are especially important. Soldiers and units at every level must be flexible and adaptive. Often stability operations require leaders with the mental and physical agility to shift from noncombat to combat operations and back again.

9-11. Stability operations help restore law and order in unstable areas outside of the US and its territories. However, the mere presence of Army forces does not guarantee stability. Offensive and defensive operations may be necessary to defeat adversaries that oppose a stability operation. The ability of Army forces to stabilize a crisis is directly related to its ability to attack and defend.

TYPES OF STABILITY OPERATIONS

9-12. Army forces may conduct stability operations before hostilities, in crises, during hostilities, and after hostilities. Before hostilities, stability operations focus on deterring or preempting conflict. In a crisis, a stability operation may resolve a potential conflict or prevent escalation. During hostilities, it can help keep armed conflict from spreading and assist and encourage committed partners. Following hostilities it can provide a secure environment that allows civil authorities to regain control. Army forces conduct the following ten types of stability operations-

- Peace operations
- Foreign internal defense
- Security assistance
- Humanitarian and civic assistance
- Support to insurgencies
- Support to counterdrug operations
- Combating terrorism
- Noncombatant evacuation operations
- Arms control
- Show of force

PEACE OPERATIONS

9-13. Peace Operations (PO) support strategic and policy objectives and their implementing diplomatic activities. POs include peacekeeping operations (PKO) and peace

enforcement operations (PEO). Although the US reserves the right to conduct PO unilaterally, it will normally participate in PO under the sponsorship of the UN or another multinational organization.

9-14. Army forces must always be ready to shift rapidly from their current mission when directed by the NCA or JFC. Optimally, forces should not transition from one PO role to another unless there is a change of mandate or a political decision with appropriate adjustments to force structure, ROE, and other aspects of the mission. As in other operations, it is crucial that commanders and staffs continually assess the mission and prepare contingency plans. In PO, this translates into planning for possible or likely transitions. Examples include transitioning from a US unilateral operation or multinational coalition to an UN-led coalition, from combat to noncombat operations, and from military to civilian control.

PEACEKEEPING

9-15. Peacekeeping operations (PKO) are military operations undertaken with the consent of all major parties to a dispute, designed to monitor and facilitate implementation of agreements (cease fire, truce, or other such agreements), and support diplomatic efforts to reach a long-term political settlement. Peacekeeping operations usually involve observing, monitoring, or supervising and assisting parties to a dispute. Army forces conducting PKO rely on the legitimacy acknowledged by all major belligerents and international or regional organizations to obtain objectives. They use or threaten force only in self-defense or as a last resort. The ongoing Multinational Force Observer (MFO) operation in the Sinai Peninsula is an example of a successful peacekeeping operation. Information support is extremely important to PKO primarily to provide force protection and situational understanding and to ensure the success of subordinate PKO related efforts.

9-16. AMD may play a major role in this operation. AMD brigades deter the threat from using TMs, ABTs, and UAVs. They deploy to the area to provide AMD protection over geopolitical targets and critical assets. THAAD and Patriot will be key systems in support of this operation. Support to NATO and the Korean government are historical examples of this type of operation. The continuing presence of US forces in Saudi Arabia provides a current example of peacekeeping operations. Special ROEs apply to this type of operation and are usually more restrictive than those ROEs during war.

PEACE ENFORCEMENT

9-17. Peace enforcement operations are the application of military force, or the threat of its use, normally pursuant to international authorization, to compel compliance with resolutions or sanctions designed to maintain or restore peace and order. Unlike PKO, PEO do not require the consent of all parties. PEO maintain or restore peace and support

diplomatic efforts to reach a long-term political settlement. Operation Restore Hope in Somalia was a PEO. Army forces assigned a PEO mission must be able to conduct combat operations. Units must be able to apply sufficient combat power for self-defense and to forcibly accomplish assigned tasks. Units must also be prepared to transition to PKO. PEO normally includes one or more of six subordinate operations:

- Forcible separation of belligerents.
- Establishment and supervision of protected areas.
- Sanction and exclusion zone enforcement.
- Movement denial and guarantee.
- Restoration and maintenance of order.
- Protection of humanitarian assistance.

9-18. AMD brigades may play a major role in PEO. Depending on the threat, all air and missile defense weapon systems may be involved. The brigades may be required to defend or enforce no fly zones between the belligerents.

Operations in Support of Diplomatic Efforts

9-19. Army forces support diplomatic efforts to establish peace and order before, during, and after a conflict. These operations include preventive diplomacy, peacemaking, and peace building. For example, Army forces support preventive diplomacy by conducting a preventive deployment or show of force as part of the effort to deter conflict. Support to peacemaking operations often includes military-to-military contacts, exercises, peacetime deployments, and security assistance. Army forces support to peace building involves the same activities as longer-term foreign internal defense (FID) operations. Military support of diplomatic activities improves the chances for success by lending credibility to diplomatic actions and demonstrating resolve to achieve viable political settlements.

FOREIGN INTERNAL DEFENSE

9-20. FID is participation by civilian and military agencies of a government in any programs taken by another government to free and protect its society from subversion, lawlessness, and insurgency. FID is a program that supports friendly nations operating in or threatened with potential hostilities. FID promotes stability by helping a host nation establish and preserve institutions and facilities responsive to its people's needs. Army forces participating in FID normally advise and assist host nation forces conducting operations. FID is also a specified and significant mission for selected ARSOF. When conducting FID, Army forces provide indirect support, direct support (not involving combat operations), or conduct combat operations to support a host nation's efforts. The AMD brigade may well be part of a FID program. The training of host nation AD personnel may be a type of program the AMD brigade will participate in during a FID

program.

Indirect Support

9-21. Indirect support emphasizes the principles of host nation self-sufficiency and builds strong national infrastructures through economic and military capabilities. Examples include security assistance programs, multinational exercises, and exchange programs. Indirect support reinforces the legitimacy and primacy of the host nation government in addressing internal problems.

Direct Support (Not Involving Combat Operations)

9-22. Direct support involves the use of US forces providing direct assistance to the host nation civilian populace or military. Direct support includes civil-military operations, intelligence and communications sharing, and logistics. Direct support does not usually involve transferring arms and equipment or training local military forces. The AMD brigade conducts direct support operations by the continual presence of AMD forces in SWA. The AMD brigade soldier's role may be the training of host nation personnel in the use of command and control nodes. This activity would require the AMD brigade commander to coordinate with the ambassador's in-country teams to preclude possible interference with an established security assistance program.

Combat Operations

9-23. Combat operations include offensive and defensive operations conducted by US forces to support a host nation's fight against insurgents or terrorists. Normally, the use of US forces in combat operations is a temporary measure. FID operations are closely scrutinized by a variety of audiences, to include the American public, international organizations, and the host nation populace. Hostile propaganda will invariably attempt to exploit the presence of foreign troops to discredit the host government and the US. Direct involvement by the US military can damage the legitimacy and credibility of the host nation government and security forces. Eventually host nation forces must stabilize the situation and provide security for the populace themselves.

9-24. Most FID activities focus on helping a host nation prevent the development of an active insurgency. If an insurgency already exists or preventive measures fail, FID focuses on the eliminating, marginalizing, or reassimilating the insurgent element into society. Military support to the counterinsurgency effort recognizes that military power alone cannot achieve lasting success. US military power cannot and will not ensure the survival of regimes that fail to meet their people's basic needs. Military programs and US actions promote a secure environment in which to implement programs that eliminate both the causes of the insurgency and the insurgents. As with other FID actions, support to

counterinsurgency must continue to balance security with economic development to enhance or reestablish stability.

9-25. Army forces conduct support to counterinsurgencies within the context of the US ambassador's country plan and the host nation's Internal Defense and Development (IDAD) strategy. The goal is to integrate all resources; civilian, military, public, and private; so that host nation combat operations and development efforts complement each other. The intended result is measurable improvement in the economic, social, and political well being of those supported. Army forces can assist in development programs by helping governmental and private agencies provide essential supplies and services.

9-26. Support to counterinsurgencies helps host governments deal with two principal groups: the insurgents and the people. Army forces help host governments protect the people from insurgent violence and separate them from insurgent control. These actions require the use of persuasion, prosecution, and destruction to attack insurgent leadership and organization. The goal is to deny insurgent organizations sources of personnel, materiel, funds, and intelligence

9-27. Army forces help the host government's police, paramilitary, and military forces perform counterinsurgency, area security, or local security operations while respecting the rights and dignity of the people. They provide advice and assistance in finding, dispersing, capturing, and destroying insurgent forces. They emphasize the training of national, state, and local forces to perform essential defense functions. Their aim is to provide a secure environment in which development programs can take effect.

9-28. Operations Just Cause and Desert One are two historical examples of this type of operation. AMD brigades must be prepared for this operation. While the brigade itself may not take part in the operation, units from its organization may be deployed. Air defense MANPADS units are ideally suited to this type of operation. Air defense provides force protection and defense of critical assets that support the development of the raiding or attack party. The Iranian Raid in Desert One is an example where air defense MANPADS were used. Avenger might be used if the threat was significant and sufficient lift assets are available. AMD brigades must ensure that its subordinate units are trained and ready for these operations.

SECURITY ASSISTANCE

9-29. Security assistance refers to a group of programs by which the US provides defense articles, military training, and other defense-related services to foreign nations by grant, loan, credit, or cash sales in furtherance of national policies and objectives. Examples of US security assistance programs are foreign military sales, foreign military financing, international military education and training, economic support fund, and Army Export

Control Act-licensed commercial sales. Army forces support security assistance efforts through military training teams, maintenance support personnel and training, and related activities such as humanitarian mine removal.

HUMANITARIAN AND CIVIC ASSISTANCE

9-30. Humanitarian and civic assistance (HCA) programs consist of assistance provided in conjunction with military operations and exercises. By law, HCA are authorized by the Secretary of State and planned and appropriated in the Army budget. HCA must enhance the security interests of the US and host nation and increase the operational readiness of the units and soldiers performing the mission. In contrast to humanitarian and disaster relief conducted under foreign humanitarian assistance operations, HCA are planned activities with specific budget limitations. HCA are limited to the following categories:

- Medical, dental, and veterinary care provided in rural areas of a country.
- Construction of rudimentary surface transportation systems.
- Well drilling and construction of basic sanitation facilities.
- Rudimentary construction and repair of public facilities.
- Specified activities related to mine detection and clearance, including education, training, and technical assistance.

SUPPORT TO INSURGENCIES

9-31. On NCA order, Army forces support insurgencies that oppose regimes that threaten regional stability or US interests. While any Army force can be tasked to support an insurgency, ARSOF usually receive these missions. ARSOF training, organization, and regional focus make them well suited for these operations. Army forces supporting insurgencies may provide logistic and training support but normally do not themselves conduct combat operations. Depending on the threat, the AMD brigade may support this type of operation. Avenger may play a major role.

SUPPORT TO COUNTERDRUG OPERATIONS

9-32. In 1986, the president issue National Security Directive 221 declaring drug trafficking a threat to national security. It is also a threat to the stability of many friendly nations. The Army participates in counterdrug operations under provisions of the National Drug Control Strategy. Army forces may be employed in a variety of operations to support other agencies responsible for detecting, disrupting, interdicting, and destroying illicit drugs and the infrastructure (personnel, materiel, and distribution systems) of illicit drug trafficking entities.

9-33. Army forces always conduct counterdrug operations in support of another US

government agency. These include the Coast Guard, Customs Service, Department of State, Drug Enforcement Agency, and Border Patrol. When conducted inside the US and its territories, they are domestic support operations. When conducted outside the US and its territories, they are considered stability operations. Army forces do not engage in direct action during counterdrug operations. Units that support counterdrug operations comply with US and foreign legal limitations on the acquisition of information on civilians and the conduct of law enforcement activities. Support to counterdrug operations include:

- Detection and monitoring
- Host nation support
- Command, control, communications, and computers
- Intelligence, planning, logistic, training and manpower support
- Research, development, and acquisition
- Reconnaissance

9-34. Air defense sensor surveillance and intelligence reporting will be the primary role for ADA brigade units. The sensors are ideally suited to provide long-range surveillance support to this type of operation. The AMDPCS can provide a pictorial display of the airspace above the international borders. This support will normally be provided to border patrol and US customs organizations along the US border.

COMBATING TERRORISM

9-35. Terrorism is the calculated use of unlawful violence or threat of unlawful violence to inculcate fear. It is intended to coerce or intimidate governments or societies in pursuit of goals that are generally political, religious, or ideological. Enemies who cannot compete with Army forces conventionally often turn to terrorism. Terrorist attacks often create a disproportionate effect on even the most capable of conventional forces. The tactics used by terrorists range from arson to the use of WMD. Army forces routinely conduct operations to deter or defeat these attacks. Offensively oriented operations are categorized as counterterrorism; defensively oriented operations are antiterrorism.

9-36. The Gulf War provides a historical example of how one nation used tactical ballistic missiles to intimidate another country. The AMD brigade possesses two systems, THAAD and Patriot, which provide significant capability against this threat. The AAMDC must provide command and control of a composite enclave and or task force for Patriot and THAAD in support of this operation. Air Defense brigades may play a minor to a major role in this type of operation.

Counterterrorism

9-37. Counterterrorism consists of offensive measures taken to prevent, deter, and respond

to terrorism. Army forces participate in the full array of counterterrorism actions, including strikes and raids against terrorist organizations and facilities outside the US and its territories. Counterterrorism is a specified mission for selected SOF that operate under direct control of the NCA or under a unified command arrangement. Commanders who employ conventional forces against organized terrorist forces operating inside their AO are conducting conventional offensive operations, not counterterrorism operations.

Antiterrorism

9-38. Antiterrorism includes defensive measures used to reduce the vulnerability of individuals and property to terrorist attacks, to include limited response and containment by local military forces. Antiterrorism is a consideration for all forces during all types of military operations. Acts of terrorism against US forces may have a strategic impact. Commanders take the security measures necessary to accomplish the mission and protect the force against terrorism. Army forces are often most vulnerable in off-duty periods and locations. Soldiers and families that reside outside protected installations are ideal targets for terrorists. Commanders make every reasonable effort to minimize the vulnerability of their force to murder and hostage taking. Typical antiterrorism actions include-

- Coordinating with local law enforcement.
- Positioning and hardening of facilities.
- Taking physical security actions designed to prevent unauthorized access or approach to facilities.
- Taking crime prevention and physical security actions that prevent theft of weapons, munitions, identification cards, and other materials.
- Establishing policies regarding travel, size of convoys, breaking of routines, host nation interaction, and off-duty restrictions.
- Providing for protection from WMD.

NONCOMBATANT EVACUATION OPERATIONS

9-39. Noncombatant evacuation operations (NEO) relocate threatened civilian noncombatants from locations in a foreign nation to secure areas. Normally, these operations involve US citizens whose lives are in danger either from the threat of hostilities or from a natural disaster. They may also include host nation citizens and third country nationals. Army forces, normally as part of a JTF, conduct NEOs to assist and support the Department of State. Removing noncombatant Americans and others from the threat of being killed or taken hostage provides humanitarian service. Relocating these potential targets expands options available to diplomatic and military authorities.

9-40. NEOs take place in permissive, uncertain, or hostile environments. Ambassadors initiate a NEO in a permissive environment in anticipation of a crisis. Direct military

involvement in these evacuations is usually not required. NEOs supported by the military are normally initiated when the local situation has deteriorated and security of the evacuees becomes uncertain or conditions are hostile. These types of NEOs are usually conducted with minimal warning. Often American lives are in immediate danger.

9-41. NEO can be conducted as a prelude to combat actions, as part of deterrent actions, or as part of a PO. Most often, evacuation force commanders have little influence over the local situation. They may not have the authority to use military measures to preempt hostile actions, yet must be prepared to protect the evacuees and defend the force. The imminent threat may come from hostile forces, general lawlessness, dangerous environmental conditions, or a combination of all three. Correctly appraising the threat and the political-military environment in which forces operate is key to NEO planning. The AMD brigade will not normally support this type of operation.

ARMS CONTROL

9-42. Army forces normally conduct arms control operations to support arms control treaties and enforcement agencies. Army forces can assist in locating, seizing, and destroying WMD after hostilities, as occurred after Operation Desert Storm. Other actions include escorting deliveries of weapons and material (such as enriched uranium) to preclude loss or unauthorized use, inspecting and monitoring production and storage facilities, and training foreign forces in the security of weapons and facilities.

9-43. Army forces may conduct arms control during combat or stability operations to prevent escalation of the conflict and reduce instability. This could include the mandated disarming of belligerents as part of a PO. Collecting, storing, and destroying conventional munitions and weapons systems can deter belligerents from resuming hostilities. Specific Army force capabilities including engineers and explosive ordinance disposal personnel are particularly suited to these operations. Air defense units and the AMD brigade do not play a role in this type of operation.

SHOW OF FORCE

9-44. The US conducts shows of force for three principal reasons: to bolster and reassure allies, deter potential aggressors, and gain or increase influence. Shows of force are designed to demonstrate a credible and specific threat to an aggressor or potential aggressor. The presence of powerful and capable forces signals to a potential aggressor the political will to use force. Combatant commanders may have established force deployment options as part of an existing contingency plan. These shows of force are designated as flexible deterrence options.

9-45. For Army forces, show of force operations usually involve the deployment or

buildup of military forces, an increase in the readiness status and level of activity of designated forces, or a demonstration of operational capabilities by forces already in the region. Although actual combat is not desired, shows of force can rapidly and unexpectedly escalate. Commanders must organize their units as if the mission requires use of force. An effective show of force must be demonstrably mission-capable and sustainable. Units assigned a show of force mission assume that combat is probable. All actions ordinarily associated with the projection of a force to conduct combat operations pertain to show of force deployments.

9-46. ADA brigade units are ideally suited for this role. A historical example is Operation Desert Storm. Early deployment of AMD shows US national resolve. It positions the unit in country to support follow-on contingency operations. AMD will provide a forward presence and defend APODs and SPODs that support the protecting force in the force projection phase of a contingency operation. AMD brigade planners must be thoroughly familiar with planning functions for this type of operation.

CONSIDERATIONS FOR STABILITY OPERATIONS

9-47. Conducting stability operations is fundamentally identical to conducting offensive, defensive, and support operations. While each stability operation is different, the decision making and troop leading procedure methodologies apply. The considerations supplement those processes and can help commanders develop tailored concepts and schemes for stability operations. Considerations for stability operations include-

- Leverage interagency, joint, and multinational cooperation
- Enhance the capabilities and legitimacy of the host nation
- Understand the potential for unintended consequences of individual and small unit actions
- Display the capability to use force in a non-threatening manner
- Act decisively to prevent escalation
- Apply force selectively and discriminately.

LEVERAGE INTERAGENCY, JOINT, AND MULTINATIONAL COOPERATION

9-48. Unity of effort requires constant coordination with all involved agencies. Stability operations require commanders to adapt to situations where lines of authority and areas of responsibility are unclear. This is important because the military is often the supporting rather than the supported agency. Commanders coordinate and integrate civilian and military activities. Likewise, commanders make clear to other agencies their military objectives and operational schemes. Coordination makes unity of effort and effective integration work in environments where unity of command is not possible. It also lends coherence to the activities of various elements involved.

9-49. Operational and tactical headquarters plan their operations to complement those of governmental and private agencies. Coordinating centers such as the civil-military operations center accomplish this task. Civil-military operations centers include representatives from as many agencies as required. Effective civil-military coordination and cooperation is necessary to mass the effects of all assets, agencies, and forces to accomplish national and multinational objectives. Effective civil-military operations reduce the use of US resources through coordination with host and third nation governmental organizations, NGOs, and international organizations operating in the AO.

ENHANCE THE CAPABILITIES AND LEGITIMACY OF THE HOST NATION

9-50. Army forces consciously endeavor to enhance host nation credibility and legitimacy. They demonstrate the proper respect for host nation government, police, and military forces. Host nation military and police forces are integrated in all aspects of every operation. The civil population will closely watch actions by Army forces. Disrespect toward host nation officials or lack of confidence in host nation capabilities by US forces will discredit the host nation and damage the stability effort.

9-51. Commanders must not allow stability issue solutions to become a US responsibility. Within their capabilities, the host nation must take the lead, in both developmental and security activities. When host nation capabilities are inadequate for the task, Army forces enhance those capabilities through training, advice, and assistance. Commanders, within the restrictions of international law and US policy, make maximum use of host nation forces and personnel for all possible activities. In any successful stability operation, the host nation- not the US forces supporting it- must ultimately prevail. The Army learned this lesson in Vietnam.

9-52. Successful FID demands a long-term investment. The factors that lead to instability or insurgency compound over time. The host nation and its supporters cannot expect to quickly correct years of problems and their consequences. The affected segments of society must see that changes are lasting and that underlying problems are being effectively addressed. The fundamental cause of insurgent activities is widespread dissatisfaction with standing ethnic, religious, political, social, or economic conditions by some sizable portion of the population. For US military power to be effective in supporting a counterinsurgency, the supported government must address or revise its policies toward the disaffected portions of the country's population. There will be few immediate, decisive results in military operations against insurgent forces. When results occur, they will be short lived unless the host government acts just as decisively to address the problems that underlie the insurgency.

UNDERSTAND THE POTENTIAL FOR UNINTENDED CONSEQUENCES OF INDIVIDUAL AND SMALL UNIT ACTIONS

9-53. Given the volatile and politically charged nature of most stability operations, individual and small unit actions can have consequences disproportionate to the level of command or amount of force involved. In some cases, tactical operations and individual actions can have strategic effects. Recognizing and avoiding potential problems requires trained, disciplined, and knowledgeable leaders and soldiers. Every soldier must understand the operational and strategic context of the mission and the potential military, political, and legal consequences of their actions or inaction.

9-54. Stability operations occur in the public view. This includes continuous observation by host nation, domestic, and international populations as well as the media. Knowing this, opponents of stability efforts will seize on relatively minor incidents to achieve strategic advantages. Potentially, a single act of indiscipline or rash application of force can undo months and years of disciplined effort. Likewise, actions that are destructive to the natural or cultural environment may introduce negative perceptions that must be overcome.

DISPLAY THE CAPABILITY TO USE FORCE IN A NON-THREATENING MANNER

9-55. Army forces must be capable of limited combat operations for self-defense. A corollary to the concept of being prepared to conduct offensive and defensive operations is the need to display such preparedness in a non-threatening manner. The intent is to demonstrate strength and resolve without provoking an unintended response. The aim of a show of force is deterrence, not an attempt to goad or bully an opponent into an attack.

9-52. Within mission constraints, units display preparedness by routinely conducting demanding combat training. Training should challenge soldiers to react to situations involving weapons use, levels of force, and ROE. Consistent with OPSEC demands, commanders make known to all parties the breadth and depth of available resources. It is not prudent to allow a potential adversary to know of all available Army force capabilities. However, displaying offensive and defensive strength can deter opponents from direct confrontation.

ACT DECISIVELY TO PREVENT ESCALATION

9-57. The nature of stability operations may limit the ways and means available to accomplish military objectives. Operational restraints do not necessarily impede the effectiveness of an Army force. Army forces act with speed and determination. Opponents may perceive hesitation to act decisively as weakness. Being overcautious can also damage the confidence of the uncommitted populations in the stability effort. Army forces must pursue military objectives energetically and, when necessary, apply military power forcefully. This does not imply that soldiers act with belligerence. Rather, in cases where force is required, commanders ensure that it is applied rapidly and decisively in a manner

calculated to end the crisis and deter future confrontations.

APPLY FORCE SELECTIVELY AND DISCRIMINATELY

9-58. An extension of the need to act decisively is the requirement to apply force selectively. Commanders ensure their units apply force consistent with and adequate to assigned objectives. They employ combat power selectively in accordance with assigned missions and prescribed legal and policy limitations. In military operations, commanders consider requirements to prevent unnecessary suffering, distinguish between combatants and noncombatants, and minimize the loss of life and damage to property. These considerations constrain or dictate the level of force acceptable. Excessive or arbitrary use of force is never justified. It may lead to the need to apply ever-increasing force to maintain the same degree of order, as well as to the loss of sympathy and support of the local populace.

9-59. Conversely, using inadequate force jeopardizes the credibility of the force. Inadequate force emboldens potential opponents and raises doubts in the minds of protected groups. Operational commanders issue ROE to guide the tactical application of combat power. Ordinarily, the commander on the ground is best qualified to determine the required degree of force, consistent with the ROE.

9-60. When available, nonlethal capabilities can provide additional tools to augment, but not replace, the traditional means of deadly force. Nonlethal means expand the number of options for confronting situations where deadly force is not warranted. However, each soldier must retain the capability to immediately apply deadly force for self-defense.

CHARACTERISTICS OF SUPPORT OPERATIONS

9-61. Support operations are usually nonlinear and noncontiguous. Adaptive and creative leaders tailor the application of the operational framework, elements of operational design, and METT-TC to fit each situation. Commanders designate the decisive, shaping and sustaining operations necessary for mission success. However, identifying centers of gravity, decisive points, and even the desired end state can be more complex and unorthodox than in offensive and defensive operations. When visualizing a support operation, commanders recognize that they may have to use a different definition of the enemy. In support operations, the adversary is often disease, hunger, or the consequences of disaster.

TYPES OF SUPPORT OPERATIONS

9-62. The two types of support operations are domestic support operations (DSO), and foreign humanitarian assistance (FHA). Army forces conduct DSO in the US and its

territories and FHA outside the US and its territories. Army forces have broader requirements and more significant and extensive obligations in DSO than FHA. Army forces normally conduct FHA operations only in a permissive environment. In uncertain and hostile environments, Army forces conduct FHA operations as part of larger stability or offensive and defensive operations.

DOMESTIC SUPPORT OPERATIONS

9-63. A presidential declaration of a major disaster or emergency usually precedes DSO. Army support to DSO supplements the efforts and resources of state and local governments and organizations. The Federal Response Plan (FRP) provides a national level architecture to coordinate the actions of all supporting federal agencies conducting consequence management, including DOD. DSO require extensive coordination and liaison among interagency, joint, multi-jurisdictional (state and local), and AC and RC entities.

9-64. Under the Constitution, civilian government is responsible for preserving public order and carrying out governmental operations within its territorial limits, if necessary by force. The Constitution allows the use of the military to execute or enforce the law to protect the states against invasion, and upon request of the state, to protect it against domestic violence. However, the Posse Comitatus Act, as amended, significantly restricts the use of military forces in federal status. It prescribes criminal penalties for the use of the Army or the Air Force to execute laws or to perform civilian law enforcement functions within the US, except as otherwise authorized by the Constitution or Congress. DOD policy extends this prohibition to the Navy and Marine Corps. The Stafford Act also defines and clarifies the role of US military forces in support of domestic civil authorities. Since the law may prohibit certain types of activities during DSO, commanders need a detailed analysis of their legal authorities for each mission.

9-65. Army forces provide domestic support primarily in accordance with DODD 3025.15, Military Assistance to Civil Authorities (MACA). The MACA directive is wide-ranging; it addresses such actions as civil disturbance control, counterdrug activities, combating terrorism, and law enforcement. Generally, the Secretary of the Army is the DOD executive agent for MACA. In domestic support operations, Army forces always support local, state, and federal civil authorities.

FOREIGN HUMANITARIAN ASSISTANCE

9-66. Army forces usually conduct FHA operations to relieve or reduce the results of natural or manmade disasters. They also conduct them to relieve conditions such as pain, disease, hunger, or privation that present a serious threat to life or loss of property. Army forces supplement or complement the efforts of host nation civil authorities or agencies

responsible for providing assistance. FHA is limited in scope and duration and focuses exclusively on prompt aid to resolve an immediate crisis. Longer-term activities designed to support full recovery and a return to pre-disaster conditions will normally become part of a combatant commander's TEP. In such cases, a FHA operation transitions to a stability operation.

9-67. Many FHA and DSO support activities, especially those involving relief operations, are similar. Distinctions relate to the different legal restrictions applied to Army forces conducting support operations inside the US and its territories. DOD has extended the restrictions of Posse Comitatus to US forces overseas (see DODD 5255.5). DODD 5100.46 establishes policy guidance for FHA operations.

9-68. Army forces execute FHA operations, usually as part of a JTF, in conjunction with the US country team of the affected country. They provide support in accordance with appropriate treaties, memorandums of agreement, memorandums of understanding, and US fiscal authority and foreign policy. The US Agency for International Development is the lead US agency for coordinating FHA. Army forces usually conduct FHA operations in support of host nation civil authorities and in concert with other civilian agencies—US, international, governmental and private.

THE ARMY'S ROLE IN SUPPORT OPERATIONS

9-69. The Army is not specifically organized, trained, or equipped for support operations. Army forces are designed and organized for warfighting. However, their warfighting capabilities allow them to support civil authorities in DSO and FHA. The Army is a disciplined force with well-established but flexible and adaptive procedures. Army units have a functional chain of command, reliable communications, and well-trained and equipped organizations that can operate and sustain themselves in an austere environment with organic assets. The Army can rapidly move large forces to the affected location using military transportation. Army engineer, military police, medical, transportation, aviation, and civil affairs assets are especially valuable for support operations.

9-70. The special qualities, capabilities, and geographic dispersion of the RC make it especially suitable for DSO. The long-term relationships with state and local officials and dispersion of RC units are ideally suited for rapid response. The US Army Reserve (USAR) has more than 2,000 units in the US, Guam, Northern Marianas Island, American Samoa, Virgin Islands, Puerto Rico, and Germany. The Army National Guard (ARNG) has units in 2,700 communities in all 50 states, the District of Columbia, Guam, Puerto Rico, and the Virgin Islands. State control of the ARNG optimizes their applicability to DSO. ARNG units do not require federal authorization to respond to emergencies; non-federalized ARNG units act on orders of the governor of their state. When in a state supporting or non-federalized role, the ARNG is not subject to the Posse Comitatus Act.

FORMS OF SUPPORT OPERATIONS

9-71. During DSO Army forces perform relief operations, support to incidents involving WMD, support to civil law enforcement, and community assistance. In FHA Army forces most often conduct relief operations; however, FHA may also involve support to incidents involving WMD and community assistance. Army forces involved in support operations execute overlapping activities.

RELIEF OPERATIONS

9-72. In case of a disaster, state, local, and host nation authorities are responsible for restoring essential services. To support their efforts or those of the lead agency, the NCA can deploy Army forces. Army forces execute similar actions during relief operations in DSO and FHA. Humanitarian relief focuses on the well being of supported populations. Disaster relief focuses on recovery of critical infrastructure after a natural or manmade disaster. Both normally occur simultaneously. Critical relief functions conducted by the Army are-

Disaster Relief

9-73. Disaster relief restores or recreates essential infrastructure. It includes establishing and maintaining the minimum safe working conditions, less security measures, necessary to protect relief workers and the affected population. This allows effective humanitarian relief and creates the conditions for long-term recovery. Disaster relief may involve consultation on and provision of emergency medical treatment and evacuation, repairing or demolishing damaged structures, restoring or building bridges, roads and airfields, and removing debris from supply routes and relief sites. Army engineer forces are well suited and often critical for disaster relief.

9-74. ADA units will not play a major role in this type of operation. ADA brigade units are not suited to this type of operation because air and missile defense equipment is too specialized to support this type of operation. However, AMD soldiers may be required to support a disaster relief operation. Non-AMD equipment from ADA units may also be used during the operation. In this case, AMD brigade personnel may be deployed for the operation.

Humanitarian Relief

9-75. Humanitarian relief focuses on lifesaving measures that alleviate the immediate needs of a population in crisis. It often includes providing medical support, food, water, medicines, clothing, blankets, shelter, and heating or cooking fuel. In some cases, it

involves transportation support to move affected people from a disaster area. Civilian relief agencies, governmental and non-governmental, are best suited to provide this type of relief. Army forces conducting humanitarian relief usually facilitate civil relief efforts.

9-76. The AMD brigade may be ordered by the National Command Authorities to participate in this type of operation. The G5 must coordinate with local authorities to outline the procedures to follow in support of civilian relief efforts. The G4 will establish special requisition procedures to obtain supplies to support this operation. The legal section must provide guidance to unit commanders on any special matters. Care must be exercised not to violate civil laws or create unfair competition to local contractors assisting in the relief operation. The air and missile defense units will not be using its equipment as originally intended. The G3 will establish special training programs to train air and missile defense soldiers on any special requirements and restrictions.

SUPPORT TO INCIDENTS INVOLVING WEAPONS OF MASS DESTRUCTION

9-77. WMD incidents are deliberate or unintentional events involving a nuclear, biological, chemical, or radiological weapon or device, or a large conventional explosive, that produce catastrophic loss of life or property. Until it is determined that the damaged site does not contain a radiological, biological or chemical agent, a large explosive event may be handled as a WMD incident. Army forces assist civil authorities in protecting US territory, population, and infrastructure before an attack by supporting domestic preparedness and protection of critical assets. When directed by DOD, Army forces can respond to a WMD incident and deal with the consequences of the event.

Domestic Preparedness

9-78. The National Domestic Preparedness Office, under the Federal Emergency Management Agency (FEMA), orchestrates the national domestic preparedness effort. Army forces have an important role in aiding domestic preparedness efforts at the local, state, and federal level. These efforts strengthen the existing expertise of civil authorities through training. They also provide the expert assistance necessary to respond to nuclear, biological, or chemical incidents. Army forces provide training to enhance state and local emergency response capabilities so they can respond to incidents. An interagency agreement establishes the Department of Justice as domestic preparedness coordinator.

9-79. Under the Department of Justice, the Center for Domestic Preparedness at McClellan, Alabama, trains emergency first responders, emergency management officials, and state and local officials to respond to terrorist acts involving WMD. The US Army's Soldier and Biological Chemical Command is engaged in implementing the city training program mandated by The Defense Against Weapons of Mass Destruction Act of 1996. Also, the Army Medical Department (AMEDD), in close cooperation with federal, state,

and local health organizations, presents courses in the medical management of nuclear, chemical, and biological casualties

Protection of Critical Assets

9-80. Hostile forces may attack facilities essential to society, the government, and the military. These assaults can disrupt civilian commerce, government operations, and military capabilities. Critical assets include telecommunications, electric power, public health services and facilities, gas and oil, banking and finance, transportation, water, emergency services, and government continuity. DODD 5160.54 identifies specific civil infrastructure assets necessary to conduct military operations. The integrity, availability, survivability, and capability of these assets are vital for conducting full spectrum operations. In conjunction with civil law enforcement, Army forces may protect these assets or temporarily restore lost capability. Army involvement in protecting critical assets complements and leverages related interagency programs and activities.

Response to WMD Incidents

9-81. Other government agencies have primary responsibility for responding to domestic terrorist and WMD incidents. Local authorities will be the first to respond to a WMD incident. However, Army forces have a key-supporting role and can quickly respond when authorized. For example, the ARNG has specialized WMD response teams that act as advance parties to facilitate follow-on deployment of other DOD assets. In a permissive overseas environment, the NCA may make Army assets available to assist a foreign government after a WMD incident. Such assistance may be linked to concurrent relief operations.

9-82. The FRP is the key plan that affects the use of Army forces in WMD incidents. The distinctions between the responsibilities of DOD and other agencies are embedded in federal law, the FRP and other federal plans, the FRP terrorist incident annex, joint doctrine, and directives. A JTF under US Joint Forces Command (USJFCOM) is responsible for C2 of military forces involved in domestic WMD incidents. It also assists civil authorities during consequence management and with protecting critical national assets.

9-83. The resources required to deal with WMD incidents differ from those needed during conventional disasters. Mass WMD casualties may require decontamination and a surge of medical resources, to include antidotes, vaccines, and antibiotics. The sudden onset of a large number of casualties may pose public health threats related to food, vectors, water, waste, and mental health. Damage to chemical and industrial plants and secondary hazards such as fires may cause toxic environmental hazards. Mass evacuation may be necessary.

9-84. The Army possesses capabilities well suited to respond to WMD incidents. Chemical units detect chemical and biological agents and decontaminate equipment and property. The US Army Medical Command (USAMEDCOM) can provide large-scale medical care. Its experienced, clinicians, planners, and support staffs can furnish assessment, triage, treatment, trauma care, hospitalization, and follow-up care for chemical and biological casualties. It can deploy a field hospital or evacuate victims to fixed facilities. It maintains special medical augmentation response teams (SMARTs) that rapidly deploy to assist in medical treatment and response. SMARTs focus on chemical and biological casualties, trauma and critical care, stress management, burns, and preventive medical threat assessment.

SUPPORT TO CIVIL LAW ENFORCEMENT

9-85. Support to domestic civil law enforcement involves activities related to counterterrorism, counterdrug, military assistance during civil disturbances, and general support. Army support involves providing resources, training, or augmentation. Federal military forces remain under the military chain of command while supporting civil law enforcement. The supported law enforcement agency coordinates Army force activities in accordance with appropriate civil laws and interagency agreements. ARNG units in state status can be a particularly useful military resource. They may be able to provide assistance to civil authorities when federal units cannot due to the Posse Comitatus Act.

Support to Counterterrorism

9-86. When directed by the NCA, military assets in support of a lead agency may operate with the Department of Justice. Army forces may provide assistance in the areas of transportation, equipment, training, and personnel. When terrorists pose an imminent threat, the US military may be used to counter these threats. The demonstrated capability to conduct these operations assists in keeping US territory from becoming a target.

9-87. Crisis management of a terrorist incident includes measures to resolve a situation and to investigate a criminal case for prosecution under federal laws. The Federal Bureau of Investigation (FBI) is the lead agency and has responsibility for crisis management within the US. Army forces may provide specialized or technical capabilities that assist in defusing or resolving a crisis. Support of crisis management includes opening lines of communication for military assistance, evacuating casualties, reconnaissance, and decontaminating or assessing WMD. In the aftermath of a terrorist incident, the military may be involved in consequence management activities including-

- Bomb dogs
- Casualty and medical assistance
- Electrical and structural engineering

- Imagery
- Explosive ordnance disposal
- Linguist support
- Mortuary affairs
- Ground transportation
- Helicopter support
- Public Affairs

Support to Counterdrug Operations

9-88. The Department of Justice, primarily through the Drug Enforcement Administration, has the responsibility for enforcing US drug laws. Drug-related crime often affects multiple local, state, and federal jurisdictions. Law enforcement agencies at all levels deal in some way with counterdrug activities. Title 10 USC strictly limits Army and federalized ARNG support to counterdrug operations. Title 32 USC, section 112, governs the use of the state-controlled ARNG forces in counterdrug operations.

9-89. Four combatant commands have counterdrug responsibilities: US Southern Command (USSOUTHCOM), US Pacific Command (USPACOM), North American Air Defense Command (NORAD) and USJFCOM. Each commander has dedicated a subordinate organization, in whole or in part, to the counterdrug mission. For example, USJFCOM maintains JTF 6 as a coordinating headquarters for military support to multi-agency counterdrug operations in CONUS.

Civil Disturbance Operations

9-90. The Army assists civil authorities in restoring law and order when state and local law enforcement agencies are unable to control civil disturbances. The ARNG is the first military responder during most civil disturbance situations. It usually remains on state active duty status throughout the operation. The president can, but usually will not, federalize the ARNG for a civil disturbance. Federal Army forces assist in restoring law and order only when the magnitude of a disturbance exceeds the capabilities of local and state law enforcement agencies and the ARNG. Army participation seeks to apply the minimum force necessary to restore order until civilian authorities no longer require military assistance. The law requires federal military forces to be used in tasks or missions appropriate to their organization and training and within legal restrictions.

General Support

9-91. Title 10 USC, sections 371-382, and other federal laws allow for additional limited military support to law enforcement agencies. The military may share information and provide equipment, facilities, and other services. Other exceptions to the provisions of the

Posse Comitatus Act are contained in the annual DOD Authorization Act, which allows specific types of military support usually related to the national counterdrug effort. DOD policies for providing military support to law enforcement agencies, including personnel and equipment, are contained in DODD 5525.5.9

9-92. DOD may direct Army forces to provide training to federal, state, and local civilian law enforcement agencies. Such assistance may include training in the operation and maintenance of military equipment. Training of federal, state, and local civilian law enforcement officials is provided under the following guidance:

- Military departments and defense agencies may provide expert advice to federal, state, or local law enforcement officials in accordance with Title 10 USC, section 373.17
- Assistance is normally limited to situations when using non-DOD personnel is infeasible or impractical from a cost or time perspective and when the assistance will not compromise national security or military preparedness.
- Assistance may not involve DOD personnel in a direct role in a law enforcement operation, except as otherwise authorized by law.
- Except as otherwise authorized by law, assistance is at a location where there is not a reasonable likelihood of armed confrontation with civilians.

COMMUNITY ASSISTANCE

9-93. Community assistance is a broad range of activities that provide support and maintain a strong connection between the military and civilian communities. Community assistance activities provide effective means of projecting a positive military image, providing training opportunities, and enhancing the relationship between the Army and the American public. They should fulfill community needs that would not otherwise be met. Community assistance activities can enhance individual and unit combat readiness. Projects should exercise individual soldier skills, encourage teamwork, and challenge leader planning and coordination skills. They should result in measurable accomplishments and increase soldier proficiency. Commanders of forward-deployed Army units may also apply these concepts when fostering or establishing relationships with host nation communities.

9-94. Community assistance at the national level enhances a cooperative relationship between the military and American people. National efforts take advantage of the technical, vocational, and group skills of military professionals. They supplement programs available from the civil sector and other government agencies. The Army's involvement in a variety of assistance programs focus on economic and social issues that have long-term national security implications. They provide opportunities for the Army to contribute to the growth and welfare of the nation, improving its perception of the military.

Army and DOD regulations provide guidance on these programs.

9-95. The Army has extensive national level responsibilities related to public works maintenance and management. The Department of the Army exercises its federal engineering executive oversight responsibilities through the US Army Corps of Engineers (USACE). The USACE manages much of the nation's public works infrastructure. Executed principally, but not solely, through the civil works directorate, this military organization integrates complex federal, state, and local regulations and policies governing the national infrastructure. These include the national waterways, environmental remediation and recovery operations, real estate, disaster recovery operations, and general project management functions.

9-96. State and local efforts also improve the community's perception of the Army. Community assistance varies widely, ranging from individual soldier involvement to full installation participation. An installation or organization can enter into an agreement with the local community to provide critical services not available in the community, augment community services unable to meet demand, or ensure that emergency services are available in the shortest possible time.

9-97. Army participation in public events, memorials, and exhibits facilitates interaction between soldiers and the local community. This contact communicates the professionalism, readiness, and standards of the Army. Individual soldiers serve as representatives and role models to the civilian community, promote and inspire patriotism, and generate interest in the Army. This increased public awareness enhances the Army's reputation and secures the confidence of the American people.

9-98. Laws, regulations, and policies limit Army participation in community assistance activities. Commanders consider the objective and purpose of community assistance. They consider limitations under which Army participation in community assistance activities is authorized. Commanders ensure that their initiatives do not compete with local resources or services and will not result in remuneration in any form. Commanders also avoid providing assistance and support to one segment of a community that cannot also be provided to others. Actions that appear to benefit a particular group can foster perceptions of bias or partisanship. Ideally, support should only be provided to events and activities of common interest and benefit across the community.

CONSIDERATIONS FOR SUPPORT OPERATIONS

9-99. Although each support operation is different, VDD, MDMP, and troop leading procedure techniques used in offensive, defensive, and stability operations still apply. The following considerations supplement those processes and can help commanders develop tailored concepts and schemes for support operations.

PROVIDE ESSENTIAL SUPPORT TO THE LARGEST NUMBER OF PEOPLE

9-100. The principle of essential support to the largest number guides prioritization and allocation. Commanders allocate finite resources to achieve the greatest good. Initial efforts usually focus on restoring vital services, which include food and water distribution, medical aid, power generation, search and rescue, fire fighting, and community relations. It may be necessary to complete a lower-priority task before accomplishing a higher one. For example, Army forces may have to restore limited electrical services before restoring hospital emergency rooms and shelter operations.

9-101. Commanders assess requirements to employ Army forces effectively. They determine how and where to apply limited assets to benefit the most people. In some cases, warfighting reconnaissance capabilities and techniques are adaptable to support operation requirements. For example, unmanned aerial vehicles can survey relief routes and locate civilian refugee groups. Standard information collection methods are reinforced and supplemented by civil affairs or dedicated disaster assessment teams, as well as interagency, host nation, and NGO sources. The combination of traditional and nontraditional information support allows commanders to obtain a clear understanding of the situation and adjust plans accordingly.

COORDINATE ACTIONS WITH OTHER AGENCIES

9-102. DSO and FHA operations are typically joint and interagency; FHA operations are also multinational. The potential for duplication of effort and working at cross-purposes is high. Unity of effort requires, at a minimum, common understanding of purposes and direction among all agencies. To ensure unity of effort and efficient use of resources requires constant coordination. Army forces enhance unity of effort by establishing a CMOC in FHA operations and by providing liaison elements, planning support, advisors, and technical experts to the lead civil authority in DSO. Commanders determine where their objectives and plans complement or conflict with those of other key agencies through these contacts. Each participant's capabilities will be in constant demand.

ESTABLISH MEASURES OF EFFECTIVENESS

9-103. In conjunction with supported agencies and governments, commanders establish relevant measures of effectiveness (MOE), similar to the tactical METT-TC factors considered during mission analysis, to gauge mission accomplishment. MOE focus on the condition and activity of those being supported. Because they are discrete, measurable, and link cause and effect, they are helpful in understanding and measuring the progress and success of the operation. In famine relief, for example, it may be tempting to measure effectiveness only by the gross amount of food delivered. This may be an acceptable MOE. However, a better MOE may be the total nourishment delivered, as measured by the total

number of calories delivered per person per day or the rate of decline of deaths directly attributable to starvation. MOE depend on the situation and require readjustment as the situation and guidance change.

HAND OVER TO CIVILIAN AGENCIES AS SOON AS FEASIBLE

9-104. The timing and feasibility of the hand over from military to civil authorities is dependent on mission-specific considerations. The two most important of these are the ability of civil authorities to resume operations without Army assistance and the necessity of committing Army forces to competing operations. Commanders identify and include other civil considerations as early as possible in the planning process. Commanders must continually consider long-term goals of the civil leadership and the communities they assist. While the immediate goal of support operations is to relieve hardship and suffering, the ultimate goal is to create those conditions necessary for civil follow-on operations. The successful hand over of all activities to civil authorities and withdrawal of Army forces is a positive signal to the supported population and the Army. It indicates that the community has recovered enough for civil agencies to resume control and that life is beginning to return to normal, and that the Army successfully completed its support mission.

RESOURCE ALLOCATION

9-105. The AMD brigade commander must husband the AMD resources under his command. These resources are personnel, equipment, time, and funds.

PERSONNEL

9-106. The personnel assigned to ADA brigade organizations have very complex specific skills. Some of these skills can be directly applied to stability and support operations. The number of people or manpower available to the brigade is fixed by the applicable table of organization and equipment (TOE). There is a limitation on manpower availability for stability and support operations.

EQUIPMENT

9-107. The equipment assigned to ADA brigade organizations has very specific purposes. Some of their equipment can be used for stability and support operations. The number and types of equipment available to the ADA brigade are fixed by the applicable TOEs. There is a limitation on equipment availability for stability and support operations. Special equipment and logistics support requirements for stability and support operations will have to be identified, received, made operational, and trained upon by the personnel.

FUNDS

9-108. The funding for stability and support operations will have to be made available to support these activities. This funding is usually provided to preselected organizations and units. This allows for the personnel of these units to train for a specific mission or set of missions for the stability and support operations. It would reduce costs in purchasing special equipment for all AMD organizations and or units by selecting certain organizations and or units to handle one or more of the support and stability activities. Expenditures of funds in this manner would provide cost benefits for manpower and or personnel utilization, special support and stability equipment requirements, and better use of time.

TIME

9-109. Effective time management of mission requirements and stability and support operations results in better use of resources. The assignment of specific organizations or units to stability and support operations results in a more effective time management. It achieves this by not requiring all organizations or units to train and equip for those operations. It allows for a more equitable use of time to train for the tactical missions to include force protection operations.

[RDL](#)[Table of](#)[Document](#)[Download](#)[Homepage](#) [Contents](#) [Information](#) [Instructions](#)

Appendix A

Threat

"...the proliferation of nuclear, biological, and chemical weapons ('weapons of mass destruction') and the means of delivering such weapons, constitutes an unusual and extraordinary threat to the national security, foreign policy, and economy of the United States..."

*President Bill Clinton
November 12, 1997*

This chapter outlines the threat to deployed US and multinational forces, LOCs, logistics facilities, and population centers from aerial attack by theater missiles. Under joint doctrine ([JP 3-01.5](#)), TMs include BMs, CMs, and ASMs whose targets are within a given theater of operation. Overviews of TM threat systems—what makes them threatening and their future trends—appear first, followed by examinations of selective countries whose current or emerging capabilities could present regional challenges. Information presented in this chapter was obtained from the Office of the Secretary of Defense and other open-source documents, such as the Air Defense Artillery School's *Air and Missile Defense Master Plan*.

GENERAL

A-1. The evolving threat will take on new, stressing characteristics in the 21st century. Adversaries will closely observe emerging US capabilities in an effort to identify and exploit weaknesses using asymmetric approaches. An asymmetric approach seeks to negate US capabilities by simple counters and avoids a direct match with US strengths. Fundamental capabilities that 21st century adversaries may pursue to counter US strengths include WMD/WMEs, unmanned RSTA platforms, precision strike, large numbers of inexpensive rockets, low-observable CMs, and information warfare. Some states will rely on asymmetric capabilities as a substitute for, or complement to, large conventional forces. Regional competition will reinforce the perceived need to acquire unmanned systems that provide high operational effectiveness for nominal cost.

A-2. Ownership of ballistic and aerodynamic systems that can strike well beyond national borders and produce mass destruction is often a source of stature in the international community. These weapons confer strategic status to the countries possessing them. Thus, a country concerned with improving the perception of its military capabilities may be tempted to acquire such systems even if it does not intend to use them.

A-3. The traditional air threat, fixed and rotary-wing aircraft, will still exist in the world of tomorrow. Fixed-wing aircraft will continue to evolve as expensive, but highly capable, multi-role weapon systems. Rotary-wing aircraft (that is, helicopters) will continue to pose a significant lethal hazard for ground forces with both improved night and standoff capabilities. While these threats are still formidable, the proliferation trend in the 21st century is toward the unmanned threat—TBM, CM, ASM, unmanned aerial vehicle (UAV), large-caliber rocket (LCR) and multiple launch rockets (MLRs).

A-4. Factors of cost, training, operational need, and strategies to counter enemy capabilities rather than match them drive the trend toward unmanned threats. TMs provide a cost-effective alternative to aircraft. For example, a single SS-1c/Scud system costs a small fraction of a fixed-wing aircraft. Significant numbers of TMs or UAVs can be acquired for the price of one or two highly sophisticated aircraft, without the attendant costs of training, maintaining, basing, and sustaining a manned aircraft fleet. [Figure A-1](#) illustrates the cost advantage of unmanned systems.

GIVEN EQUAL FUNDING, ANY ADVERSARY COULD BUY...

- 40 "Off-the-Shelf" Cruise Missiles
- 30 Recon UAVs
- 15 TBMs with TELs
- 10 Utility Helicopters
- 4 Attack Helicopters
- 1-2 Fixed-Wing Fighters



**Increasing Risk
to Contingency
Forces**

Low Cost/High Payoff Drives Changing Threat

Figure A-1. Unmanned Systems Cost Advantage

A-5. The advantages of unmanned systems may be worth their economic cost. These systems possess inherent lethal capabilities, and they are increasingly available on the world market. Since most developing nations have virtually no effective defense against a TM threat, TMs provide an excellent deterrent. Investment in substantial numbers of these may have a higher payoff value than an equal value investment in manned systems.

A-6. Sophisticated and rudimentary versions of these unmanned systems pose a danger to deployed US military forces. TBMs and CMs can deliver WMD/WME on deployed forces or geopolitical assets. RSTA UAVs can detect US force operations and provide the basis for near real-time targeting, leading to potential disruption of decisive operations. LCRs and MLRs pose special hazards and challenges across the spectrum of operations.

HISTORICAL PERSPECTIVE

A-7. The military and political use of TMs by other countries since World War II is increasing. [Table A-1](#) lists TM use events in chronological order.

Table A-1. Theater Missile Use By Other Countries Since World War II

<i>YEAR</i>	<i>EVENT</i>	<i>MISSILE</i>
1973	Egyptian and Syrian attacks on Israel	FROG/Scud
1980-88	Iran-Iraq War	FROG/Scud
1986	Libyan attacks on US Coast Guard Base, Lampedusa, Italy	Scud
1989-91	Afghan Government use on Mujahideen	Scud
1991	Iraqi attacks during the Persian Gulf War on Bahrain, Israel, and Saudi Arabia	FROG/Scud
1993	North Korean missile tests	Scud/No Dong
1993-95	Yugoslav Civil War	FROG/SA-2
1994	Yemeni Civil War	Scud/Scarab
1995	Iran-Iraq border clash	Scud/SA-2
1995-96	Chinese missile tests	M-9
1998	North Korean missile test	Taepo Dong
1998	Pakistani missile test	Ghauri

THEATER MISSILE THREAT TO ARMY OPERATIONS

A-8. TMs are unique weapon systems. Their capabilities give a country the ability to attack

US and multinational forces, LOCs, logistics facilities, and population centers from the beginning to the end of hostilities. During force projection operations, TM targeting requirements will evolve as the political and military situation changes and the availability of threat TM systems change during the conflict.

STAGES I AND II—MOBILIZATION AND PREDEPLOYMENT

A-9. The TM threat is to in-theater US and multinational forces and other assets. Therefore, the TM threat during mobilization and predeployment operations of US forces is limited. The enemy may conduct a preemptive strike with the intent of preventing or seriously disrupting US deployment operations. This could be achieved by influencing the US will to commit forces, or through the destruction of key deployment infrastructure. Enemy TM targeting requirements will be relatively the same against in-theater US as well as multinational allied forces during this stage.

STAGES III AND IV—DEPLOYMENT AND ENTRY OPERATIONS

A-10. Initially the operational objective of TM forces may be to slow the flow of forces into the area of operations (AO) and cause enough casualties to influence US public opinion against national involvement. TMs may be used against such high-value targets such as APODs, SPODs, logistic sites, TMD forces, marshaling and staging areas, and political targets.

A-11. TBMs will probably be the enemy weapon system of choice during these operations. Their high survivability, range, penetration, and warhead options make them ideal during most phases of operations. Their lethality allows them to be effective against population centers and to disrupt operations at APODs and SPODs.

A-12. Enemy fixed-wing or rotary-wing aircraft operations may peak during this stage, especially if enemy forces launch a preemptive strike. Although enemy aircraft may suffer a high attrition rate, the threat of aircraft armed with CMs and ASMs will continue to exist throughout this phase. Air-launched weapons will probably be fired at maximum range, possibly limiting the effectiveness of friendly active defenses against the launching aircraft.

A-13. Land attack CMs (LACMs) will probably be used to target APODs and SPODs, but can be used against virtually any fixed target. Cargo and transport ships may be attacked with CMs while in SPODs. LACMs are most likely to be employed in precision strikes against high-value targets, but may be used to deliver WMD/WME payloads.

STAGE V—DECISIVE OPERATIONS

A-14. The enemy weapon systems active during entry operations will be active during the

decisive operations stage, and their target lists will be expanded to include troop concentrations and choke points. Nuclear, biological, and chemical (NBC) weapons may be used to disrupt and delay operations. It can be assumed that fixed-wing aircraft levels will decrease during this stage, lowering, but not eliminating, the ASM and air-launched CM threat.

STAGES VI, VII, AND VIII—POST CONFLICT THROUGH DEMOBILIZATION

A-15. Enemy TM system operations should be limited during these stages, though history has proven that TBMs are highly survivable and mobile ground-launched CMs have a similar potential. Large concentrations of forces throughout these three phases prove to be easy targets for both TMs and CMs. However, further enemy use of TM systems would reinitiate hostilities, so their likelihood of use should be reduced.

THEATER BALLISTIC MISSILES

A-16. TBMs include short-range ballistic missiles (SRBMs) with ranges up to 1,000 km and medium-range ballistic missiles (MRBMs) with ranges from 1,000 to 3,000 km. These are surface-launched missiles with ballistic trajectories. TBMs, often launched from highly mobile, difficult-to-detect transporter erector launchers (TELs), have the capability to carry WMD/WME. Most TBMs are single-stage missiles with a circular error probable (CEP) accuracy of one-tenth of one percent of the range. State-of-the-art guidance technologies in some missiles will improve this accuracy to less than 50 m. [Figure A-2](#) displays a number of TBM threats.

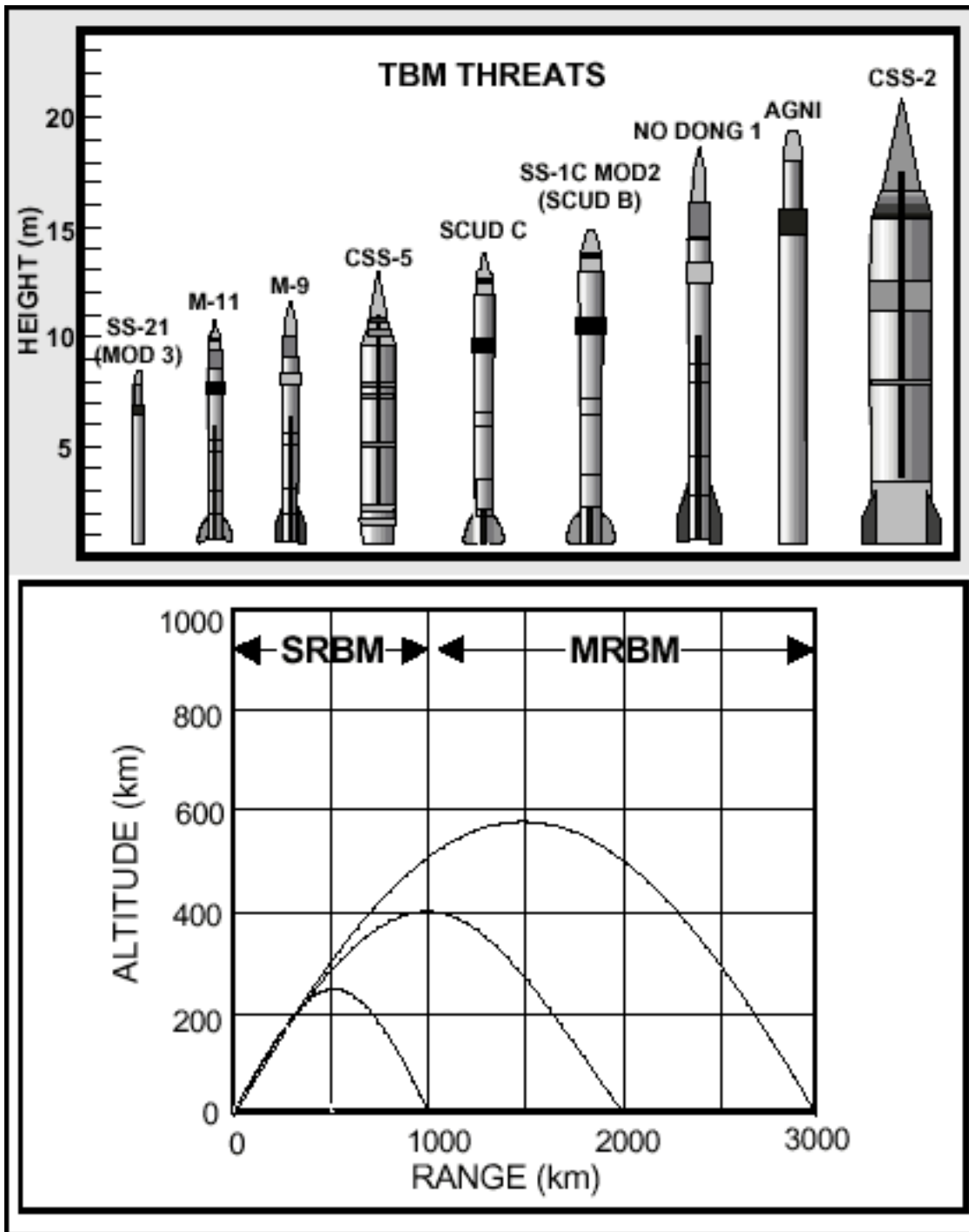

Figure A-2. Theater Ballistic Missiles Threats

A-17. TBMs are inherently difficult to defend against. Characteristics that increase TBM effectiveness include a reduced radar cross section (RCS), high terminal velocity, reduced notification time for defending forces, a variety of difficult-to-kill warheads, and an all-weather capability. [Figure A-3](#) illustrates the threatening characteristics of TBMs.

THEATER BALLISTIC MISSILE		
TARGETS	CAPABILITIES	WARHEADS
<ul style="list-style-type: none"> • Geopolitical/population centers • Air and sea ports • Command and control centers • Logistical areas • Troop concentrations 	<ul style="list-style-type: none"> • Range = 3000+ km • Accuracy = within 100 m • Pre-launch detection extremely difficult • Low radar signature 	<ul style="list-style-type: none"> • Ideal for WMD • Nuclear • Biological • Chemical • Conventional high explosives • Submunitions

Figure A-3. Features That Make Theater Ballistic Missiles Threatening

A-18. The major TBM trends are increased range and improved accuracy. Currently, many potential adversaries employ inaccurate TBMs targeted at fixed military targets and population centers. However, the TBM lack of accuracy is offset by the use of WMD/WME warheads or submunitions. As potential adversaries acquire TBMs with improved accuracy, range, and payload capacity, TBMs will become more tactically effective. Integration of global positioning system (GPS) and terminal guidance are the current focus of improving accuracy. Also, the trend in modern missile systems has been toward the use of solid propellants because of the reduced logistical requirements and simplicity of operations. Solid fuels and multiple staging will increase TBM payloads and ranges. Improved TBMs may target C² nodes, air defense sites, fire support sites, assembly areas, and logistics concentrations. They can be used to exploit choke points and create obstacles. This will be facilitated through the use of military and commercial satellite support, UAVs, and real-time news reporting.

A-19. For most potential adversaries TBMs are strategic systems, organized in former Soviet-style Strategic Rocket Forces (SRF) units. As a result the decision to commit TBMs will be strategic rather than tactical. Orders, including targeting data and launch site location, will be passed via fixed national communications channels rather than mobile tactical channels. Generally, TBM brigades and battalions will serve as communications relays and sources of logistical support. Firing batteries will direct TELs to emerge from protected locations, move to prepared launch sites, fire TBMs, and then return to protected locations for reload operations. These operations will generally occur during periods of darkness and poor weather to reduce the effectiveness of TMD attack operations.

A-20. The organization of TBM forces on strategic lines provides vulnerabilities that can be exploited. Strategic operations reduce the operational flexibility of the adversary TBM force. National authorities will tend to employ TBMs against predictable fixed geopolitical assets and facilities, allowing our active defenses to mass. The exercise of national

command authority will slow both the target selection and passing processes, allowing our passive defenses time to regenerate between attacks. The operation from strategic fixed locations provides years of intelligence collection; facilitates our identification of TBM C², communications, hide sites, launch sites, and logistics facilities; and allows high confidence attack operations.

LARGE-CALIBER AND MULTIPLE LAUNCH ROCKETS

A-21. While technically not missiles, LCRs and MLRs appear with TBMs in this document because their size, trajectory, warheads, and battlefield targets are similar to those of SRBMs. LCRs are different from SRBMs in that they do not have onboard guidance and, thus, are unguided throughout their flight. Typical LCR systems are the Russian Luna M or free rocket over ground (FROG) series and the US Honest John. MLRs also lack onboard guidance, overcoming this shortfall by being employed in volleys of a hundred or more rockets on a single target. Typical MLRs are the Brazilian Astros, Russian Smerch, and US MLRS.

A-22. The ability of these systems to deliver high volumes of fire and a variety of warheads makes them ideal weapon systems for fire support missions. Highly mobile launchers effectively support forward artillery missions. This mobility and the rocket's short burn time result in little warning for maneuver forces, and their short range precludes engagement by current missile defense systems. [Figure A-4](#) illustrates the MLR characteristics.

MULTIPLE LAUNCH ROCKETS		
TARGETS	CAPABILITIES	WARHEADS
<ul style="list-style-type: none"> • Assembly areas • Missile defense/artillery locations • Defensive positions • Troops in the offense • Chokepoints/routes of advance 	<ul style="list-style-type: none"> • High rates of fire • Highly mobile ("shoot and scoot") • Rapid reload • Area denial • Low signature/flight trajectory 	<ul style="list-style-type: none"> • Ideal for massive ordnance delivery • Chemical • High explosives • Bomblets • Mines

Figure A-4. Features That Make Large-Caliber Rockets and Multiple Launch Rockets Threatening

A-23. MLRs are widely proliferated, and their production and sale is increasing. The high volume of fire and multiple warhead capabilities of MLRs make them a very appealing weapon system for threat nations. In the future, threat nations may incorporate simple guidance schemes, and deploy passive infrared (IR) or radio frequency (RF) warheads with

these missile systems, improving their use against armor systems, C² nodes, and battlefield radars.

CRUISE MISSILES

A-24. CMs are unmanned, powered, self-guided vehicles that exhibit sustained flight through aerodynamic lift at one or more predetermined, constant (cruise) altitudes and carry a warhead or other lethal payload. There are two primary missions and, thus, two types of CMs—anti-ship cruise missile (ASCM) and LACM. The Army is most concerned with the LACMs.

A-25. CMs are reliable, accurate, survivable, and lethal. They can be launched from the land, air, or sea. In flight, they are difficult to detect, can fly indirect routes (low or high) to avoid heavily defended areas, and can attack from any direction. Today's CMs can hit a target with remarkable accuracy; tomorrow's smarter and more accurate CMs will pose a far greater threat.

A-26. Only a limited number of LACMs are currently deployed. However, numerous countries (for example, China, France, Germany, Israel, Italy, Russia, and South Africa) have ongoing LACM development programs.

A-27. Emerging CMs pose serious threats because of their unique operational characteristics illustrated in [Figure A-5](#). The incorporation of new technologies in airframe and warhead design, propulsion systems, and guidance systems has contributed to vastly improved systems. The increased use of composite materials in airframe construction has created stronger and lighter airframes. A range of low observable and stealth technologies has reduced the RCS. The increased use of air-breathing turbojet and turbofan engines permits subsonic speeds, providing longer ranges and flight altitudes as low as 20 m above ground level (AGL). Sophisticated guidance systems, such as GPS, the inertial navigation system (INS), and terrain contour matching (TERCOM) contribute to overall accuracy and allow programming of unpredictable flight paths to optimize surprise. A terminal guidance seeker increases accuracy to less than 10 m. A wide array of conventional warheads, to include submunitions, allows targeting of both soft and hard targets. NBC weapons pose the most serious threat, but currently only Russia, France, and the US have CMs with nuclear warheads. However, the development of a chemical or biological warhead is not difficult. The May 1997 Quadrennial Defense Review report noted that the use of NBC weapons is a likely condition of future warfare and that these weapons could be delivered by several means, including CMs.

CRUISE MISSILE		
TARGETS	CAPABILITIES	WARHEADS
<ul style="list-style-type: none"> • Geopolitical/population centers • Air and sea ports • Command and control centers • Logistical areas • Troop concentrations 	<ul style="list-style-type: none"> • Range = 30 to 3000 km • Air, ship, or ground launched • 360° threat - unpredictable ingress route • Launch detection/impact prediction extremely difficult • Very low radar signature • Highly accurate 	<ul style="list-style-type: none"> • Ideal for WMD • Nuclear • Biological • Chemical • Conventional high explosives • Submunitions

Figure A-5. Features That Make Cruise Missiles Threatening

A-28. The success of US CM operations in the Gulf War has led to increased interest in these systems and spurred current worldwide developments. Threat experts foresee an increase in the number of LACMs within the next ten years, as well as extended ranges, improved accuracy, reduced RCSs, and increased lethality. The development of systems such as the Russian AS-18/KAZOO (Kh-59M Ovod-M), Israeli AGM-142 Popeye, and US AGM-84E Standoff Land Attack Missile (SLAM) blur the distinctions between CMs and ASMs, and their proliferation presents a grave threat to tactical operations. The addition of smart submunitions will allow the engagement of armored units on the move in the near future. CM countermeasures and evasive maneuvers are also potential future capabilities.

AIR-TO-SURFACE MISSILES

A-29. ASMs are air-launched, precision-guided munitions designed to strike ground targets. They are ideal against targets, such as bridges, that are difficult to destroy with "dumb" bombs. They are similar to air-launched CMs, but are smaller, have shorter ranges, lack the wings and aerodynamic lift associated with CM flights, and are launched by fighter-bomber aircraft. Russia and Free World countries widely export ASMs, and they are operational in numerous air forces around the world.

A-30. ASMs are an extremely lethal threat because of their versatility and pinpoint accuracy ([Figure A-6](#), page A-10). Most threat ASMs are of Russian origin and employ radio command, laser, anti-radiation homing, or electro-optical (EO) guidance systems. Missiles that employ anti-radiation homing systems are referred to as anti-radiation missiles (ARMs); they represent the greatest threat to air defense, artillery (counter-battery), aviation, and intelligence radars. Most ARMs have ranges of over 100 km. An aircraft firing an ARM will usually launch from outside the lethal envelope of the air defense system being attacked. Laser-guided systems place the attacking aircraft in harm's

way because of their short range, generally less than 10 km. EO or video-guided systems and ARMs offer the greatest standoff range and aircraft survivability. Some EO systems have ranges in excess of 100 km.

AIR-TO-SURFACE MISSILE		
TARGETS	CAPABILITIES	GUIDANCE SYSTEMS
<ul style="list-style-type: none"> • Armored vehicles • Radars • Bridges and similar "point" targets 	<ul style="list-style-type: none"> • Supersonic speed (Mach 3) • Extremely accurate • Short flight time • Launch and leave • Fire and forget • Lock-on-after-launch 	<ul style="list-style-type: none"> • Radio command • Anti-radiation (with blind-mode guidance) • Laser • Electro-optical (TV) • Dual mode seekers (in future)

Figure A-6. Features That Make Air-To-Surface Missiles Threatening

A-31. ASMs, like CMs, are becoming smarter and more versatile, reliable, accurate, and lethal. New capabilities may include a lock-on-after-launch capability or a loitering capability to attack enemy radars (for ARM variants) and may use dual mode seekers for increased reliability and combat capability.

UNMANNED AERIAL VEHICLES

A-32. UAVs include drones, characterized by preprogrammed flight paths and patterns, and remotely piloted vehicles (RPVs), controlled by ground-based operators. Each can perform a variety of missions, ranging from reconnaissance and battlefield surveillance to attack and electronic warfare.

A-33. UAVs serve as RSTA information platforms for target detection, identification, and location; weapon targeting; target designation; and battle damage assessment (BDA) ([Figure A-7](#)). State-of-the-art sensors and data links provide real-time targeting for fire support systems, maneuver forces, and aircraft. UAVs, equipped with laser designators, provide immediate targeting of assets for attack by smart munitions.

UNMANNED AERIAL VEHICLE		
TARGETS	CAPABILITIES	PAYLOADS
<ul style="list-style-type: none"> • Assembly areas, logistical areas, command and control centers (seeing) • Troop movements (seeing) • Command and control and sensor nodes (jamming) • Armored formations/systems (attacking) 	<ul style="list-style-type: none"> • Multimissioned - RSTA, electronic warfare, or attack • Range = up to 1900 km • Altitude = 300 m to 17+ km • Flight time = 15 min to 48 hr • Small radar signature 	<ul style="list-style-type: none"> • Daylight TV and infrared video cameras • Film cameras • Electronic intelligence • Electronic warfare • HE warheads

Figure A-7. Features That Make Unmanned Aerial Vehicles Threatening

A-34. The low RCS, low speed, and small thermal signature of UAVs make them difficult to detect and engage. Mission-dictated flight profiles take full advantage of terrain, increasing system survivability, and optimizing coverage. Flight altitudes are normally between 1,000 to 3,000 m AGL. UAVs conducting RSTA missions fly at altitudes safe from small arms fire.

A-35. UAV payloads consist of daylight television, IR video, and film cameras (for reconnaissance missions). Other major payload categories include electronic warfare (EW), electronic intelligence, radar, and attack warheads.

A-36. Several nations are developing and fielding anti-radiation homing UAVs with the primary mission of attacking battlefield RF emitters (radars, communications). These platforms have a variety of launch options and are usually fire-and-forget systems. Other attack UAV systems employ terminal guidance to kill tanks or fighting vehicles.

A-37. Threat experts project more than 50 UAV developer countries and 75 UAV user countries by 2005. In addition to information gathering (still the dominant function), UAV roles will include electronic combat, decoy, ground attack, and suppression of enemy air defense (SEAD). A significant new capability involves the direct linkage of a reconnaissance UAV to an artillery unit's fire direction center. This linkage provides near real-time information to ground commanders, followed by immediate fire and damage assessment. UAVs are also good candidates for stealth technology and spin-off technologies from CM developmental programs.

GLOBAL THREAT ENVIRONMENT

A-38. With the fall of the Soviet Union, US interests have now broadened, and the number of potential conflict areas around the world has increased dramatically. In accordance with

the Defense Planning Guidance (DPG), the military may now deploy forces to many regions of the world where potential adversaries possess significant air and missile threats, including those with WMD/WME payloads. These potential adversaries are also seeking to develop nuclear weapons.

BELARUS

A-39. Belarus inherited an extensive inventory of TM systems from the former Soviet Union (FSU), to include SS-1c/Scud B and SS-21/Scarab SRBMs, and has no known chemical or biological warfare programs. While Belarus' national policy supports US and United Nations (UN) sponsored nonproliferation initiatives, serious concerns remain regarding their export policies and security measures. Belarus exports weapon systems, but it has a poor record of safeguarding weapons and nuclear material. Continued economic difficulties require massive infusions of hard currency that could be obtained through the sale of TM or WMD/WME systems or associated technologies.

CHINA

A-40. China is deeply involved in the development of BMs with capabilities that span ranges and payloads from theater to intercontinental. China has developed the following types of BMs: SRBMs (CSS-6/M-9, CSS-7/M-11, and CSS-8); MRBMs (CSS-2 and DF-21); intermediate range ballistic missile (IRBM) (CSS-3); intercontinental ballistic missile (ICBM) (CSS-4); and submarine launched ballistic missile (SLBM) (JL-1). It is aggressively seeking markets for its weapons industry (for example, China has exported the CSS-2 to Saudi Arabia, the CSS-8 to Iran, and M-11 to Pakistan). The transfer of Chinese missile and nuclear technology to potential threat countries adds to the threat facing the US and its allies. The range capabilities of Chinese BM systems are shown in [Figure A-8](#).

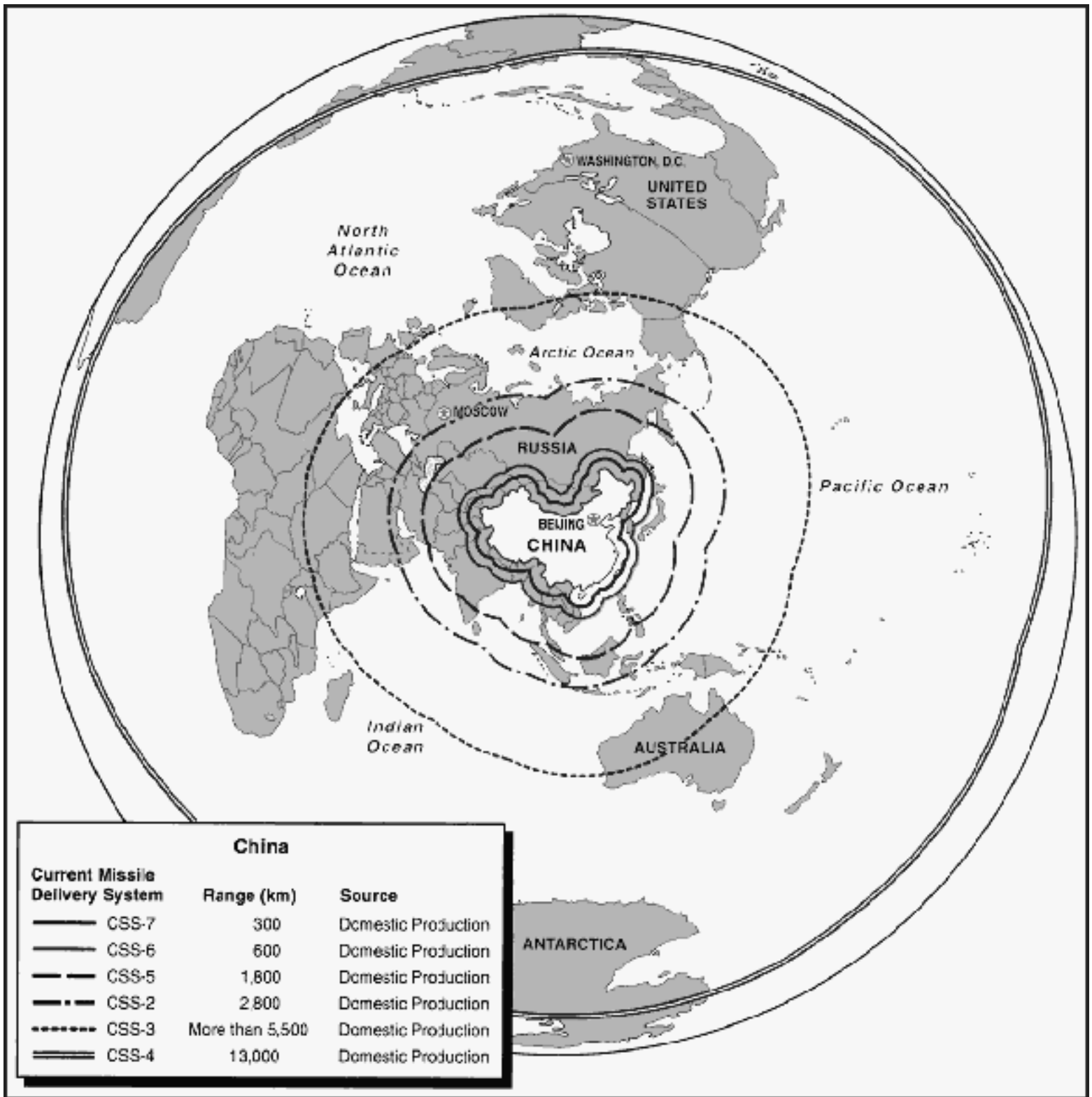

Figure A-8. Ranges of Chinese Ballistic Missile Systems

A-41. China maintains a robust inventory of MLRs, with at least 18 different systems with ranges to 40 km. China’s eagerness to export these weapons to other potential threat nations makes their use likely against US forces.

A-42. The Chinese are also active in CM development, basing this development primarily

on the SS-N-2/Styx provided by the Soviets in the late 1950s. The HY-1/Silkworm and the HY-2 are the Chinese versions of the Russian Styx; they are limited in range and not considered high-tech systems. In the mid-1980s, China appeared to have reverse-engineered the French Exocet into the C-801 and has exported this system. Although China lacks an LACM capability, it may be developing a long-range spin-off of its ASCM programs.

A-43. The Chinese aerospace industry is actively developing new UAVs. In 1996 China displayed the ASN-206, designed to perform a variety of missions ranging from day and night aerial reconnaissance to battlefield surveillance. The ASN-206 is reportedly available for export.

INDIA

A-44. India will probably become self-sufficient in all areas of missile production in the near future. India has two missile programs: the Prithvi SRBM, with a range of 250 km and the Agni MRBM, with an approximate range of 2000 km, both of which could be used to deliver WMD/WME. India also has an ambitious space-launch vehicle program that could easily lead to ICBMs. The range capabilities of Indian missile systems are shown in [Figure A-9](#).

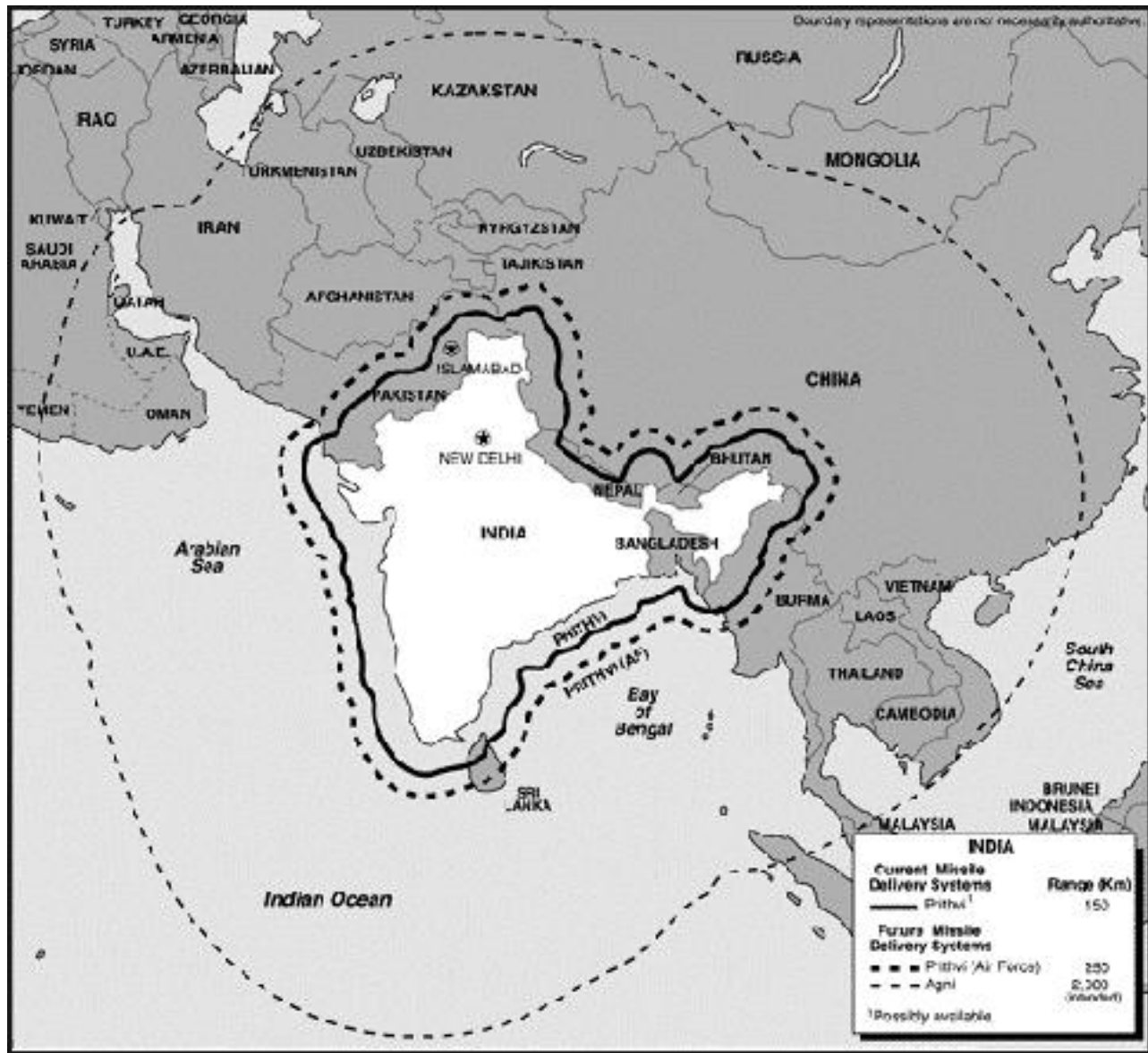

Figure A-9. Ranges of Indian Ballistic Missile Systems

A-45. India has a variety of MLR, CM, and UAV development programs. India has developed a 45-km range, 214-mm MLR designed to "shoot and scoot," each launcher has its own computerized fire control system. Its ASCM inventory includes the French Exocet and the Russian Styx and Starbright. It also developed the Lakshya, a LACM reportedly derived from a target drone. India currently has at least two indigenous UAV programs underway. It is also experimenting with a mini-UAV, similar to the Israeli Mazlat Pioneer system.

IRAN

A-46. Iran has placed a high priority on rebuilding its armed forces since its defeat in the Iran-Iraq War of 1988. Iran has emphasized the acquisition of power-projection capabilities, TMs, aircraft, and submarines to oppose intervention. This effort includes the

development or acquisition of WMD/WME. Iran is attempting to build an indigenous capability to produce nuclear weapons, has had a biological warfare program since the early 1980s, and has produced large quantities of chemical agents since 1984.

A-47. Iran first acquired Scud B missiles from Libya and North Korea and used them during the Iran-Iraq War. Later, it received Scud B and C missiles from North Korea and CSS-8 missiles and components from China. It has launched a two-track missile program, acquiring Scud missiles and missile equipment from North Korea and establishing its own production capability. The range capabilities of Iranian BM systems are shown in [Figure A-10](#).

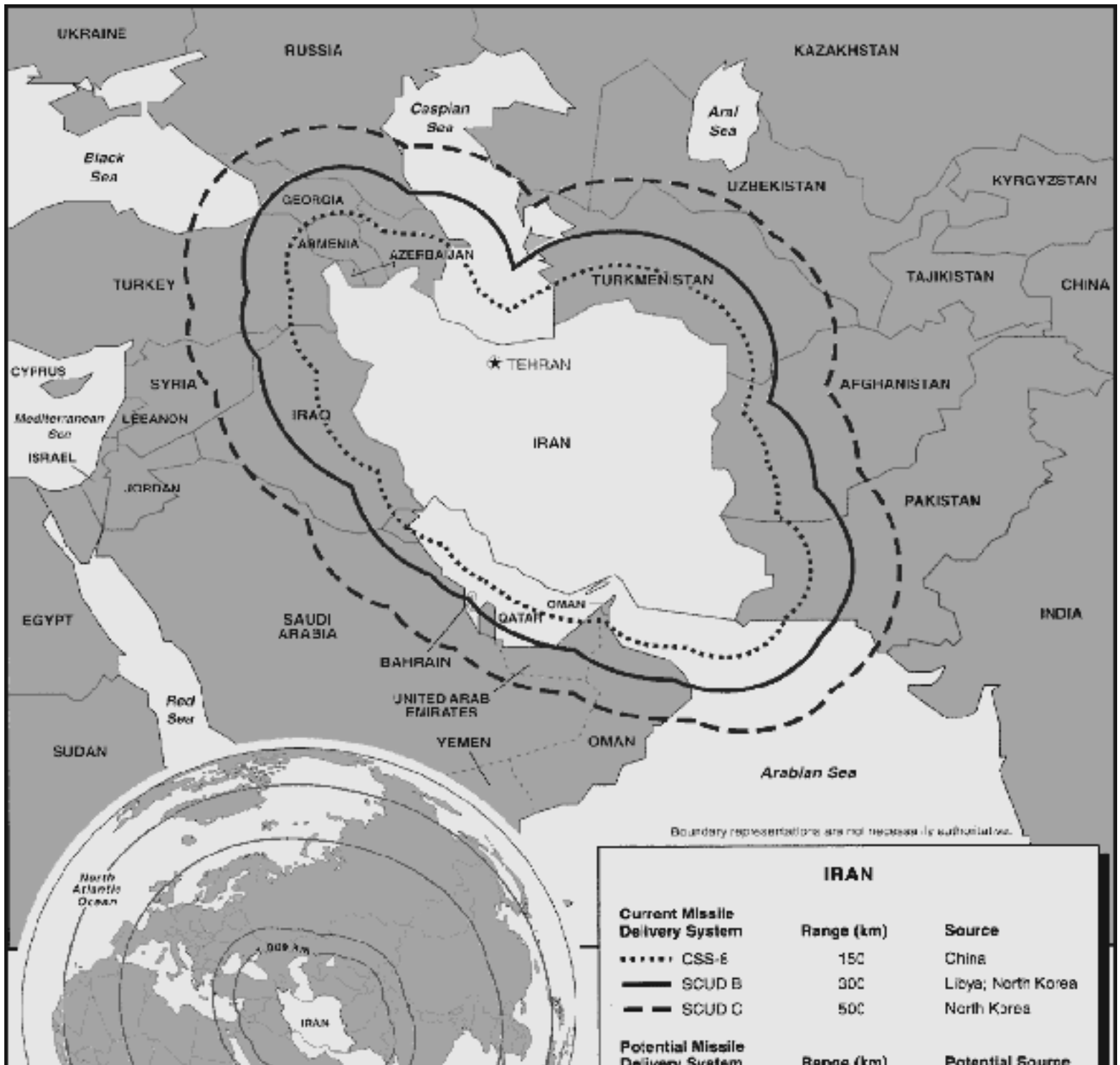

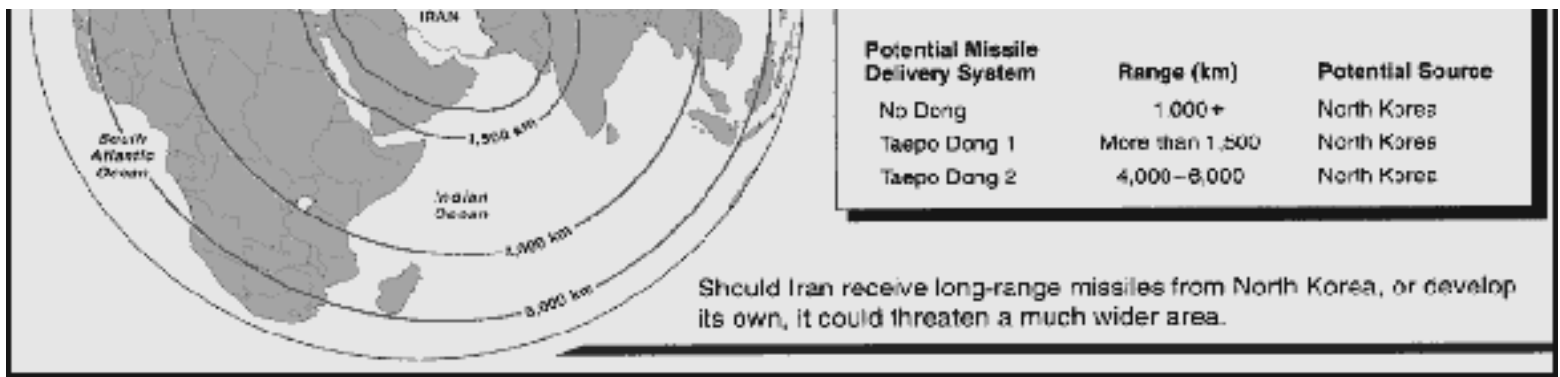

Figure A-10. Ranges of Current and Future Iranian Ballistic Missile Systems

A-48. Iranian forces field a variety of LCRs and MLRs to support the Iranian Army and the Iranian Revolutionary Guard Corps. The LCRs, ranging in size up to 355.6 mm, are capable of delivering high explosives or, possibly, chemical weapons.

A-49. Iran has Chinese land-based and shipborne ASCMs and Russian ASMs. Iran is expected to continue to rely on China for ASCMs and, when available, LACMs.

A-50. Iran currently operates a limited UAV capability using the Sahahin, a radio-controlled battlefield reconnaissance drone, and the Baz, a radio-controlled reconnaissance drone with a reported attack capability. Iran operates several squadrons of UAVs, and there is concern that it may be developing the UAVs as a means of delivering chemical and biological agents.

IRAQ

A-51. Despite Iraq's defeat in the 1991 Gulf War, Saddam Hussein's goal is to establish Iraq as the leading Arab political and military power in the Middle East and to dominate the Persian Gulf. Iraq continues to seek the capability to employ WMD/WME. It has an extensive biological warfare program, has produced several thousand tons of chemical agents since the 1980s, and it continues to pursue a nuclear weapons production capability.

A-52. Iraq is believed to be hiding some quantity of TBMs, TELs, and other ground support equipment (GSE) and maintains some equipment needed to produce TBMs and rockets. Today, Iraq focuses its efforts on developing the Ababel 50, a Yugoslav-designed, 50-km range MLR, and the Ababel 100 SRBM. Iraq's artillery force includes rockets having a range of up to 100 km with submunitions dispensers, and the Layth-90 LCR, an Iraqi 90-km variant of the Russian FROG-7. The range capabilities of Iraqi BM systems are shown in [Figure A-11](#).



Figure A-11. Ranges of Current and Future Iraqi Ballistic Missile Systems

A-53. Iraq effectively used an ASCM, the French Exocet missile, to damage the *USS Stark* in the Persian Gulf. The Iraqis have a limited number of C-601, C-801, Exocet, and HY-2 ASCMs in their inventory and are expected to acquire an LACM capability. Indigenous development programs have resulted in the Faw family of ASCMs, derived from the Russian Styx.

A-54. Prior to the Gulf War, Iraq had several developmental UAV programs. Today, there is no evidence of full-scale production, and it is assessed that only a few UAVs exist.

KAZAKSTAN

A-55. Kazakstan inherited an extensive inventory of TM systems from the FSU, but has no known chemical or biological warfare programs. While Kazakhstan’s national policy supports US and UN-sponsored nonproliferation initiatives, serious concerns remain

regarding their export policies and security measures. Kazakhstan exports weapon systems, but it has a poor record of safeguarding weapons and nuclear material. Continued economic difficulties require massive infusions of hard currency that could be obtained through the sale of TM or WMD/WME systems or technologies.

LIBYA

A-56. Libya's TBM inventory is currently limited to the Scud B, but they have LCR, MLR, ASCM, and UAV capabilities. Libya is conducting both TBM and WMD/WME research and development (R&D). The development of an indigenous MRBM, or the acquisition of a foreign one such as the North Korean No Dong, would give Libya the capability to reach regional adversaries. They could target all of Egypt, much of Algeria, most of Israel, and portions of Europe including Athens and Rome. The Libyans have weapon stocks of chemical agents and are conducting low-level research on biological and nuclear weapons.

NORTH KOREA

A-57. North Korea has conducted extensive research, development, and production of TBM and WMD/WME systems over the last 10 years. They have developed, produced, fielded, and exported two Scud missile variants, the North Korean Scud B and Scud C, both capable of carrying WMD/WME. The fielding has provided North Korea with an extensive TBM infrastructure capable of launching hundreds of missiles deep into South Korea. The exports have included complete TBM systems consisting of missiles, TELs, and other GSE; disassembled electronic components for assembly by the receiving country; and production equipment. Countries in the Middle East, such as Iran and Syria, have received hundreds of these missiles.

A-58. North Korea is in the late stages of developing and fielding a new MRBM, the No Dong. Two additional new missile systems are in design and test, the Taepo Dong 1 MRBM and Taepo Dong 2 IRBM. Most recently, they have begun testing longer range multistage systems. The range capabilities of North Korean BM systems are shown in [Figure A-12](#).

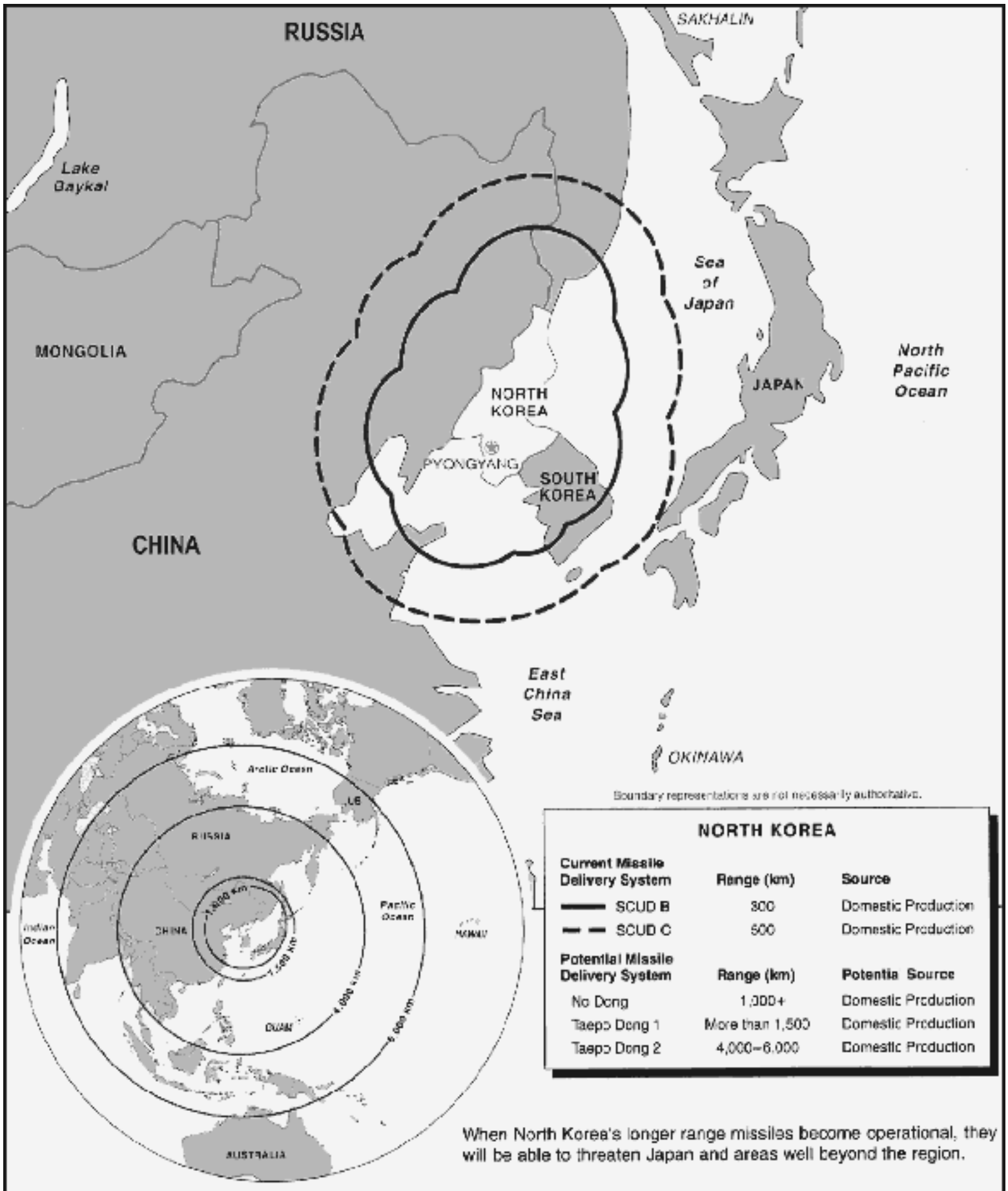

Figure A-12. Ranges of Current and Future North Korean Ballistic Missile Systems

A-59. In addition, North Korea has produced more than 4,000 MLRs. These MLRs, based on Chinese systems, have ranges from 20 to 43 km. They produce two types of ASCMs based on the Russian Styx technology and the Chinese HY-1 and HY-2 missiles. However, it currently lacks a LACM capability. North Korea maintains a limited number of target drones, which might be used as decoys or attack systems.

PAKISTAN

A-60. Pakistan, like India, has both nuclear weapons and the TBMs capable of delivering them. Pakistan has purchased the M-11 SRBM from China and is developing its own family of SRBMs, the Hatf I, II, and III. The Hatf I and II are based on French technology and are operational. Intelligence analysts believe the Hatf III, still in development, is based on the Chinese M-9 and M-11 technology.

A-61. Pakistan has a limited ASCM capability consisting primarily of Chinese Silkworm ASCMs. China is expected to remain Pakistan's most important supplier of missile-related technology.

RUSSIA

A-62. Russia is the primary recipient of the weapons inventories, production facilities, and technologies of the FSU. These resources include the largest stocks of TMs in the world. Russia's TBM inventory is limited to thousands of SS-1c/Scud B and SS-21/Scarab SRBMs as a result of the Intermediate Nuclear Force (INF) Treaty, which required the elimination of the FSU's extensive stocks of MRBMs. Russia possesses the bulk of the FSU's BM industrial base and remains capable of developing and producing the full range of solid and liquid propellant BMs and associated technologies. The SS-X-26 SRBM is in development, and is expected to be both a replacement for the SS-1c/Scud B and an export.

A-63. Russia maintains a large number of tactical and strategic nuclear weapons. It has the world's largest and most advanced chemical warfare program and has a considerable stockpile of nerve, blister, and choking agents. Russia may also be retaining its biological warfare production capability.

A-64. Russia's use of LCRs and MLRs can be traced to the Russian Katyusha system in World War II. Since then, the Russians have increased the range, caliber, accuracy, and variety of warheads for their rocket systems.

A-65. Russia began developing UAVs as early as 1950. The early systems were adaptations of obsolete full-size aircraft and large missiles. Newer systems, such as the Schmal, have been developed based on the successes of smaller, dedicated tactical UAVs in Chechnya.

A-66. Russia's national policy supports US and UN-sponsored nonproliferation initiatives. Nevertheless, serious concerns remain regarding Russian export policies and security measures. Russia continues to exhibit a vast array of weapons systems at international air shows, and it has exported an assortment of weapons to numerous countries. Continued economic difficulties require massive infusions of hard currency that could be obtained through the sale of TM or WMD/WME systems or technologies.

A-67. Russia has a poor record of safeguarding weapons and nuclear material. To date, thefts have focused primarily on small arms and military goods that are readily convertible to cash. Recent events have shown that nuclear material is available on the black market and within reach of potential terrorist countries. In addition, the emigration of Russian scientists, engineers, and technicians with experience in development of TM and WMD/WME technologies could provide other countries with access to critical research and production know-how, thereby accelerating their capabilities.

SYRIA

A-68. Syria acquired SS-1c/Scud B and SS-21/Scarab SRBMs from the FSU in the mid-1970s and the 1980s. Syria has received supplies of Scud-related equipment and materials from both North Korea and Iran. In parallel with the production program for the liquid propellant Scud, Syria (with foreign support) has devoted significant resources to establishing a solid propellant rocket motor development and production capability. Syria is laying the groundwork for a future option to develop a modern, solid propellant SRBM.

A-69. Syria may have chemical warheads available for a portion of its TBM force, enhancing this force's value as either a strategic deterrent or an actual weapon. In addition, Syria has a variety of Russian land and sea-launched short-range ASCMs and ASMs.

UKRAINE

A-70. Ukraine inherited an extensive inventory of TM systems from the FSU including SS-1c/Scud B and SS-21/Scarab SRBMs, but it has no known chemical or biological warfare programs. While Ukraine's national policy supports US and UN-sponsored nonproliferation initiatives, serious concerns remain regarding their export policies and security measures. Ukraine exports weapon systems, but it has a poor record of safeguarding weapons and nuclear material. Continued economic difficulties require massive infusions of hard currency that could be obtained through the sale of TM or WMD/WME systems or technologies.

TRANSNATIONAL THREAT

A-71. Transnational groups—including terrorists, insurgents, opposing factions in civil

war, and members of organized criminal groups—are proliferating. Such groups are not generally bound by the same constraints or motivated by the same factors as nation states, and they pose significant threats to the interests of the US and its allies.

A-72. With numerous ongoing insurgencies and civil wars worldwide, there are additional dangers of escalation if NBC weapons or missiles are introduced. Opposing factions in civil wars, gaining access to TMs and WMD/WME, might threaten or actually use TMs with WMD/WME against civilian targets for either psychological or strategic effect; or they could use these weapons against conventional forces to disrupt staging or resupply efforts.

SUMMARY

A-73. The number of countries with the potential to present regional challenges to the US and its allies will increase as the capabilities of these countries increase. While traditional air threats such as fixed-wing aircraft and helicopters will continue to improve, the acquisition of new, lower-cost, unmanned threats—TBMs, CMs, ASMs, UAVs, and LCRs—adds greater lethality. TBMs, in addition to being effective terror weapons, will have a more significant military role as their range and accuracy improve. LCRs and MLRs with multiple warhead options and long-range, high rates of fire are another deadly threat. CMs and ASMs are difficult to detect, highly accurate, and can attack from any direction. UAVs will add new attack, decoy, and targeting missions though still emphasizing the traditional reconnaissance mission. The use of WMD/WME is a likely condition of future warfare, and many of the unmanned threat platforms are capable of delivering such weapons. These emerging threats present a serious challenge to TMD.

A-74. Rogue countries such as Iran, Iraq, Libya, North Korea, and Syria continue to threaten global security and the stability of their respective regions. The tension between India and Pakistan exacerbated by recent nuclear testing by both countries is of serious concern. Belarus, China, Kazakstan, Russia, and the Ukraine have extensive inventories of TMs and access to either WMD/WME or WMD/WME technologies. They also have national needs that can be facilitated through weapon exports.

[RDL](#)[Table of](#)[Document](#)[Download](#)[Homepage](#) [Contents](#) [Information](#) [Instructions](#)

Appendix B

Air Intelligence Preparation of the Battlefield

This appendix describes the IPB process as it applies to AD operations. The breakup of the former Soviet Union has caused the Army to shift its focus from the Soviet threat to regional threats. With the current lack of a single well-defined threat to plan against, the IPB process will provide continuous input toward defining that threat. Developing templates will be more challenging and more critical in support of the IPB process.

PROCESS

B-1. [FM 2-01.3](#) explains the IPB process in detail. The commander uses IPB to understand the battlefield and the options it presents to friendly and threat forces. IPB is a systematic, continuous process of analyzing the threat and environment in a specific area. By applying the IPB process, the commander gains the information necessary to selectively apply and maximize his combat power at critical points in time and space on the battlefield. Airspace, or the aerial dimension, is the most dynamic and fast paced of the three dimensions. The intelligence staff must consider all the aspects of air operations and must be aware of the capabilities of all air threats, to include UAVs, ballistic missiles, cruise missiles, TASM's, and rotary- and fixed-wing aircraft. The G2 and S2 have overall staff responsibility for IPB. ADA and aviation officers must provide input to the G2 and S2 when integrating air aspects into the IPB process. The IPB process has four steps:

- Define the battlefield environment
- Describe the battlefield's effects
- Evaluate the threat
- Determine threat courses of action

B-2. Since terrain, weather, and other characteristics of the battlefield have different effects on air operations and AMD operations, aerial IPB differs from ground IPB. Enemy forces must be evaluated in relation to the effects that weather, terrain, and friendly operations will have on them. The most significant threats that must be evaluated for aerial IPB are UAVs, ballistic missiles, cruise missiles, and fixed- and rotary-wing aircraft. Aerial IPB is an integral part of the IPB process at all levels.

DEFINE THE BATTLEFIELD ENVIRONMENT

B-3. The battlefield includes aerial dimensions to an area of operations, battle space, and an area of interest. Therefore, each of these parts of the battlefield framework may be different from that of ground force operations.

AREA OF OPERATIONS

B-4. The air area of operations is the area where the commander is assigned responsibility and authority for military operations. It usually is, but does not necessarily need to be, identical to the ground area of operations in width and depth. It extends vertically up to the maximum altitude of friendly ADA systems.

BATTLE SPACE

B-5. Battle space is a physical volume that expands or contracts in relation to the ability to acquire and engage the enemy. It varies in width, depth, and height as the commander positions and moves assets over time. Battle space is not assigned by a higher commander and can extend beyond the commander's area of operations.

AREA OF INTEREST

B-6. The area of interest is the geographic area and the airspace above it from which information and intelligence are required to facilitate planning or successful conduct of the commander's operation. Because the commander and staff need time to process information and plan and synchronize operations, the commander's area of interest is generally larger than the area of operations or battle space. It is also larger due to the great distances that air and missile systems can rapidly cover. The air area of interest will extend vertically to cover the maximum service ceilings or trajectories of aircraft, UAVs, and missile systems. Horizontally, it will extend to cover the maximum range of aircraft, UAVs, and missiles, plus threat airfields, forward arming and refueling points, navigation aids, and missile sites. The area of interest extends to the limits from which intelligence and information must be gathered about enemy forces, which could affect friendly forces.

DESCRIBE THE BATTLEFIELD'S EFFECTS

B-7. The effects of terrain and weather on the enemy and friendly forces must be analyzed. They are different than the effects on ground operations.

TERRAIN ANALYSIS

B-8. Terrain analysis in support of air and missile defense is significantly different from terrain analysis for ground operations. The nature of airspace does not eliminate the need for terrain analysis because enemy air and friendly ADA will still attempt to use terrain to their own best advantage. IPB focuses on the impact of geographic factors on the ability of threat air to approach, acquire, and engage a target, or deliver airborne or air assault troops. Analysis of the terrain for IPB follows the same principles as ground analysis and uses the military aspects of terrain (OCOKA).

Observation and Fields of Fire

B-9. These aspects relate to the influence of terrain on reconnaissance and target acquisition. In the IPB context, observation relates to optical and electronic line of sight. Many battlefield systems require line of sight to effectively operate or acquire and engage targets. These systems include radios, radars, jammers, direct-fire weapons, and airborne and ground sensors as well as friendly ADA systems. Fields of fire relate to the terrain effects on weapon systems. Airspace must be analyzed with regard to routes, which provide the best protection for air threats entering the target area, and those, which provide the best fields of fire once they reach the target area.

Cover and Concealment

B-10. Cover and concealment have slightly different applications with respect to air systems. The following tactics and techniques fall into the context of cover and concealment:

- Contour flying is flying a constant altitude above ground level (AGL) of less than 22.8 meters (75 feet). This allows for maximum use of terrain masking.
- Pop-up tactics are the use of a low-altitude approach to the target area. Target acquisition and engagement is made by popping up in altitude at a predetermined position or time to minimize exposure.
- Masking is using terrain to protect an air system from visual and electronic observation or detection. Electronic warfare supplements natural masking.
- Cover is using terrain to provide protection from direct-fire weapon systems.
- Ground clutter can be characterized as a reduction of electromagnetic signal-to-noise ratio due to the signature of a background. It is different for each type of terrain or feature.

B-11. Threat aircraft, cruise missiles, and possibly even UAVs will use contour flying, masking, and ground clutter to avoid detection and to provide cover from direct fires. Aircraft will also use the terrain by loitering on reverse slopes, using pop-up tactics, and by using ground clutter and vegetation as a backdrop to enhance concealment.

Obstacles

B-12. Obstacles are broken down into three primary types:

- Those, which prevent the effective employment of ADA systems
- Those, which restrict contour flight
- Those, which force air threats to employ a particular surveillance or attack profile or route, or to gain excessive altitude

B-13. Of particular interest are obstacles and terrain, which restrict lateral movement within an avenue of approach. This will canalize movement or restrict evasive action. Additionally, terrain may stop the employment of certain air threat systems if the terrain exceeds the system's maximum operating ceiling. Obstacles should be plotted on a Modified Combined Obstacles Overlay (MCOO).

Key Terrain

B-14. Key terrain is any locality or area in which the seizure, retention, or control of it will afford a marked advantage to either combatant. In the aerial dimension, key terrain consists of terrain features that canalize or constrain air threat systems and terrain with an elevation higher than the maximum ceiling of air threat systems. Additionally, areas that can be used for airfields, landing and drop zones, or forward arming and refueling points also need to be considered as key terrain, since these areas could be used to support friendly or threat air operations. Terrain can be used as an aid to navigation. Man-made features are also used as cues to navigate to targets.

Air Avenues of Approach

B-15. Air avenues of approach are evaluated using the same criteria as for ground. A good air avenue of approach will permit maneuver while providing terrain masking from surface-to-air weapon systems. Some common air avenues of approach are valleys, direct lines from the enemy point of origin, and river beds. In order to determine air avenues of approach, both ingress and egress, the following factors should be considered:

- Type of air threat, attack profile, and ordnance
- Air threat point of origin and ground control radar positions
- Probable threat objective
- Potential to support maneuver forces
- Freedom to maneuver within the air avenue
- Protection afforded to the air system and pilot
- Air threat and pilot capabilities

Type of air threat

B-16. UAVs are small and elusive. They usually fly low. Altitude can vary. Once in the target area, they may fly an orbit attempting to stay out of engagement range of ADA. Most surfaced-launched cruise missiles are terrain following and use terrain masking. Due to their range, they may take indirect approach routes. Ballistic missiles are not terrain dependent, and they are not restricted by terrain. They fly a straight ground track from launch point to objective. TASMs usually fly direct routes from launch platform to the target. Rotary-wing aircraft primarily conduct contour flights. They follow ridge lines and military crests, using the terrain to mask their approach to the target area. Fixed-wing aircraft usually follow major terrain or man-made features. Depending on range, they may fly a straight line to the target. Ordnance or payload may affect range and altitude of the air system and thus influence the selection of avenues of approach.

Point of origin

B-17. When determining air avenues, the staff looks at the commander's entire area of interest. Analysis begins at the threat airfield or UAV or missile launch site and works toward the probable enemy objective. This allows a look at the big picture. The staff considers the range of the air systems and location of navigation aids and ground control sites.

Probable threat objective

B-18. Each avenue of approach must end at a target, drop zone, or landing zone; or within reconnaissance, intelligence, surveillance, or target acquisition range of a target. Reverse IPB is used to pick threat objectives that support maneuver forces. Air assets, which are used to achieve ground objectives, will seek to use air avenues of approach coincident with ground avenues of approach. Air assets attacking deep are not limited to these ground avenues. Ground corridors do not limit missiles and ISR UAVs. The answers to the following questions determine the value of the avenue of approach. For freedom to maneuver, does the avenue—

- canalize the air system,
- have access to adjacent avenues,
- provide for target acquisition and use of available munitions,
- assist in navigation?

For protection for the air system and the pilot, does the avenue provide—

- terrain masking (cover and concealment),
- for the full use of air system speed,

- protection against radar detection,
- protection from air defense weapon systems and tactical air support,
- a standoff orbit location,
- a standoff orbit?

For air threat and pilot capabilities, can the air system or pilot—

- perform contour flying,
- fly at night,
- fly in all weather conditions,
- range the targets?

WEATHER ANALYSIS

B-19. Air operations are especially susceptible to the effects of weather. Weather analysis for air and AMD operations is designed to predict the most likely time over target and other considerations based on weather effects and light data.

B-20. Many of the same factors the G2 or S2 considers for ground operations are as follows:

- Visibility has a significant impact on offensive air operations and ISR. Visibility has the same effects on visually-directed ADA systems and sensors.
- High winds will hinder maneuver, close air support, and target engagement, especially in tight air avenues of approach. Missiles and UAVs will be adversely affected in performance and accuracy.
- Precipitation affects aircraft, missile, and UAV performance and reduces the effectiveness of sensors. Precipitation reduces ADA sensor range.
- Cloud cover and ceilings may restrict operations by setting low operational ceilings and restricting visibility and target engagement.
- Low ceilings, overcast, and clouds may restrict visually-directed ADA weapons' detection and acquisition ranges.
- Extreme temperature and humidity have a severe effect on aircraft and UAVs by decreasing combat range, altitude (particularly rotary-wing aircraft), and ordnance loads.

EVALUATE THE THREAT

B-21. Threat evaluation for air operations consists of a detailed study of enemy air capabilities, organization, and doctrine. The following steps should be used when evaluating the threat:

- Collect and analyze doctrinal threat data
- Analyze threat air capabilities
- Conduct target evaluation

COLLECT AND ANALYZE DOCTRINAL THREAT DATA

B-22. Typical questions, which should be answered during this step, must also include the commander's critical information requirements and priority intelligence requirements. They are as follows:

- What are the major strategic, operational, and tactical objectives of the enemy's air operations?
- Which objectives may be targeted for destruction or suppression?
- Where do friendly air and missile defense assets fit into the enemy's objectives? Do they need to be destroyed or suppressed for the enemy plan to work? Answers to these two questions may result in modification to air avenues of approach.
- What is the enemy's air order of battle? How are the assets organized? Knowledge of threat organization, and who has operational control, will indicate the importance of the area of operations. For example, if the enemy's bombers are at theater level and are in the area of operations, then that area is probably receiving the theater's main attack. What is the size of his ballistic missile brigade, battalion, and battery? Does it fire as a unit? Does the threat have mobile, fixed, or both types of launchers?
- Who has tactical control of aircraft at the point of attack?
- How will UAVs be used, for example, battle damage assessment, attack, or ISR? What are the associated profiles?
- How does the enemy doctrinally attack? Will the enemy use airborne, air assault, or special operations forces in conjunction with an air or ground attack? What sizes are these forces and to what depth are they used? Will the enemy synchronize the air attack? Does the enemy have the capability to coordinate an air attack (possibly with varied air threat platforms that can overmatch friendly air and missile defense capability)?
- What are air system combat ingress and egress speeds?
- Where are previously reported missile launch positions? What are the likely targets? What are the range, endurance, and profile of these systems?
- What are the doctrinal distances for forward arming and refueling points? If the enemy's maximum range falls short of the area of operations, where is the enemy likely to stop and refuel, or be aerially refueled?
- How and where will the enemy attack ground targets for interdiction?
- At what altitude will the enemy approach the target, deliver munitions, and exit the target area?
- What is the release authority of certain types of ordnance? This is particularly important when dealing with NBC threats.
- How does the enemy employ reconnaissance assets?

- How has the enemy historically fought?

ANALYZE THREAT AIR CAPABILITIES

B-23. ADA units evaluate a broad range of order of battle data and threat capabilities to include the ground force and EW threat to ADA units. They also evaluate the answers to the following questions.

Aircraft

B-24. What are the capabilities of the air systems in terms of—

- The enemy's capability to coordinate air-to-ground attacks?
- The enemy's capability to coordinate air and artillery operations? Are ground forward air controllers used?
- The enemy's capabilities for suppression of friendly air and missile defense?
- Performance (speed, altitude, airfield restrictions, troop and weapon load capacity)?
- Endurance and range (ingress and egress altitudes and speeds)?
- Levels of combat readiness and sortie generation rate?
- Ability to conduct pop-up maneuvers? What is the standoff range?
- Target acquisition capability, night and adverse-weather capability, and identification ranges?
- The standoff ranges for cruise and tactical air-to-surface missiles?
- Ordnance load (maximum weight, type, load mixture, and level of sophistication)?
- Combat personnel load?
- Navigational capability (type of radar; can it fly at night or in adverse conditions)?
- Combat radius (with or without external tanks, ordnance, and location of staging bases)?
- Loiter time (how long can they stay on station over the target area)?
- Countermeasures environment? For example, will standoff jammers, ground-based jammers, reconnaissance or chaff-laying UAVs, or aircraft degrade friendly air and missile defense systems?
- Type, quantity, and quality of training the pilot has received?
- How much do they conform to doctrine?
- Ability of pilots to fly at night or perform contour flying? During peacetime, did the pilot conduct the type of mission expected to be conducted during war?
- Types and capabilities of threat ordnance? Each type of ordnance should be evaluated for range, accuracy, release altitude, reload and refire time, warhead type, and guidance type.

Unmanned aerial vehicles

B-25. What are the capabilities of threat UAVs in terms of—

- Performance (speeds, altitude, and launch restrictions)
- Endurance and range
- Contour flying or terrain limiting factors
- Target acquisition and standoff range
- Sensor package and payload (maximum weight, type, and load mixture)
- Loiter time (how long can the UAV stay on station)
- Visibility effects on acquisition
- Modes of recovery and turnaround time
- Real-time, data-link capability
- Guidance modes (ground controlled and preprogrammed)
- Crew proficiency

Tactical ballistic missiles

B-26. What are the capabilities of threat TBM systems in terms of—

- Performance (flight time, speed, trajectory, launch restrictions)
- Maximum and minimum ranges
- Circular error probable
- Crew proficiency
- Reload and refire time? What is the number of TBMs available per transporter erector launcher
- Warhead type and size
- Guidance modes
- Location of surveyed launch sites

Cruise missiles

B-27. What are the capabilities of threat cruise missiles in terms of—

- Performance (flight time, speed, altitude, and launch restrictions)
- Maximum and minimum ranges
- Circular error of probability
- Targeting capabilities and type
- Contour flying capability
- Vulnerability to countermeasures
- Guidance modes
- Warhead type and size

CONDUCT TARGET VALUE EVALUATION

B-28. This should determine what targets are to be labeled as high-value targets. High-value targets are assets the enemy or friendly commander has deemed as important for the successful accomplishment of his mission. High-value targets are determined by operational necessity and weapon system capability.

DETERMINE THREAT COURSES OF ACTION

B-29. Determining both the threat air and ground courses of action, integrates the results of the previous three steps into a meaningful conclusion. After evaluating the threat, what are the enemy's likely objectives and what COAs are available to him? The G2 or S2 develops enemy threat models that depict the threat's air and missile COAs. They also prepare event templates and matrices that focus intelligence collection on identifying which COA the threat will execute. The process of developing these templates and matrices is covered in depth in [FM 2-01.3](#). The decision support template is an integrated staff product that results from the war gaming of potential friendly COAs.

SITUATION TEMPLATE

B-30. Situation templates are graphic depictions of expected threat dispositions should they adopt a particular COA. They usually depict the most critical point in the operation as agreed upon by the G2 and G3. However, the G2 or S2 might prepare several templates representing different snapshots in time starting with the initial threat array. The situation template integrates air attack and surveillance profiles with terrain. It focuses on specific air avenues of approach and mobility corridors. It determines which avenues are the most capable of supporting attack techniques and profiles. It will identify the most direct routes to landing and drop zones to protect and ensure the survivability of air threat systems.

EVENT TEMPLATE

B-31. The event template is a guide for collection and reconnaissance and surveillance (R&S) planning. It depicts named areas of interest (NAIs) where the commander expects to see certain activities of tactical significance and is used to confirm or deny an enemy course of action. These NAIs are based on the terrain constraints on air approach routes to potential targets and analysis of the enemy's attack and ISR profiles. The G2 or S2 develops an event matrix to support the event template by providing details on the type of activity expected in each NAI, the times the NAI is expected to be active, and its relationship to other events on the battlefield. Examples of NAI include landing and drop zones, forward arming and refueling points, forward staging areas, and previous TBM launch locations.

DECISION SUPPORT TEMPLATE

B-32. The decision support template is based on the situation and event templates, event matrix, and the war gaming of friendly COA results. It should depict the following events:

- Air avenues of approach
- Airborne and air assault objectives
- Landing and drop zones and largest size enemy element which could be employed at the zone
- Ranges of enemy systems
- Ranges of friendly air and missile defense systems
- Target areas of interest (TAIs)
- Decision points (DPs)

B-33. Air TAIs and DPs are determined in the same manner as they are for ground operations. However, due to the high speeds of air systems, decision points must be placed significantly farther in advance of the TAIs.

CORRELATION OF FORCES-AIR

B-34. Correlation of Forces-Air (COFA) is a method of comparing weapon systems, and more importantly, evaluating probable results of both enemy and friendly courses of action. The COFA is based on the probability of kill (pk) of specific weapon systems against other specific weapon systems. The COFA takes into account weapon range, velocity, lethality, and survivability. The COFA is calculated for both enemy and friendly courses of action. The intelligence officer and operations officer analyze the probable result of the enemy course of action against the friendly air and missile defense design. COFA cannot be used in isolation. The total capabilities of weapon systems must be applied and factors such as training, TTP, weather, and visibility conditions must be considered. Additionally, the advantage of the defense should be factored into the analysis. Part of that advantage is an availability of an external air picture which allows Patriot radars to operate in passive modes. Friendly forces will know the location of enemy aircraft without revealing their locations. [Tables B-1 through B-4](#) list COFA values for various weapon systems. These values are utilized for planning purposes only.

Table B-1. Air and missile defense systems vs. aircraft

System	Range	Value
Patriot	>50	4.5
Linebacker	>5	1.6
Avenger	>5	1.2
MANPADS Stinger	>5	.3

Table B-2. Aircraft

Type	Speed	Example	Value
Fighter	>Mach 2	F-15, F-16, MiG-31, MiG-29	.5
Fighter	>Mach 1	F-18, Su-17, Su-24	.4
Fighter	<Mach 1	A-10, AV-8B, Su-25	.3
Bomber	>Mach 1	B-1, Tu-22, Tu-160	.4
Bomber	<Mach 1	B-52, Tu-142	.3
Attack Helicopter		AH-64, Mi-24	.6
Transport Helicopter		UH-60, Mi-8	.4

Table B-3. Air and missile defense systems vs. TBM

System	Range	Value
THAAD	>100	4.8
Patriot (GEM)	>20	4.5
Patriot	>20	4.0

Table B-4. TBM

Type	Range (km)	Value
Taepong Dong	1400	>3.0
NoDong	1100	>3.0
Al Abbas	>800	2.8
Al Hussein	>600	1.8
SCUD C	>500	1.6
SCUD B	300	1.2
SS-21	120	1.0

B-35. The methodology for calculating COFA and performing analysis consists of multiplying the number of weapon systems by their value to obtain a COFA value that can be compared to other weapon systems. For example, if a flight of four MiG 29s attacked one Patriot battery the COFA would be:

$$4 \times \text{MiG 29 (>Mach 2 Fighter)} \quad 4 \times 0.5 = 2 \text{ COFA}$$

$$1 \times \text{Patriot Battery} \quad 1 \times 4.5 = 4.5 \text{ COFA}$$

One (1) Patriot battery defeats a flight of four (4) MiG 29 aircraft.

B-36. The enemy may attack with several weapon systems with different COFA values. To calculate the COFA for several different systems, determine each system separately and then add the values together. For example, the enemy attacks one Patriot battery with six MiG 29 and four SU-17.

$$6 \times \text{MiG 29 (>Mach 2 Fighter)} \quad 6 \times 0.5 = 3 \text{ COFA}$$

$$4 \times \text{SU-17 (>Mach 1 Fighter)} \quad 4 \times 0.4 = 1.6 \text{ COFA}$$

$$= 4.6 \text{ COFA}$$

$$1 \times \text{Patriot Battery} \quad 1 \times 4.5 = 4.5 \text{ COFA}$$

Six (6) MiG 29 and four (4) SU-17 defeat one (1) Patriot battery

B-37. The same methodology applies to defending with different weapon systems. If, in the above example, one Avenger platoon were incorporated into the defense, the COFA would change.

6x MiG 29 (>Mach 2 Fighter) 6x.5 = 3 COFA

4x SU-17 (>Mach 1 Fighter) 4x.4 = 1.6 COFA

= 4.6 COFA

1x Patriot Battery 1x4.5 = 4.5 COFA

1x Avenger 1x1.2 = 1.2 COFA

= 5.7 COFA

One (1) Patriot battery and one (1) Avenger platoon defeat six (6) MiG 29 and four (4) SU-17.

B-38. COFA analysis is a tool used by the S2 and S3. The COFA analysis is used during the war gaming process and the analysis of the COA.

APPLYING IPB

B-39. IPB is a systematic, continuous process of analyzing the threat and environment in a specific geographic setting. Applying the IPB process helps the commander apply and maximize his combat power at critical points in time and space by determining the threat's likely COA, and describing the environment and its effects on operations. Preparation and continuous updates of the aerial portion of IPB are fundamental to the execution of the air and missile defense and land force missions on the modern battlefield.

[RDL](#)[Table of](#)[Document](#)[Download](#)[Homepage](#) [Contents](#) [Information](#) [Instructions](#)

Appendix C

ADA Communications

This appendix provides an overview of ADA communications as it relates to ADA brigade operations. It addresses the aspects of air and missile defense communications, the responsibilities of the commander, and operational control as they relate to theater air and missile defense. Additionally, it explains the communications systems, intelligence networks and data link protocols used by the commander and his staff to integrate and coordinate the planning and execution of successful air and missile defense operations.

COMMUNICATIONS

C-1. ADA brigade communications must be an integrated system of doctrine, procedures, organization structure, personnel, equipment, and facilities designed to support the air and missile defense mission. Theater and corps communications systems must allow the commander to exercise his authority in both FO and EO throughout all phases of a force projection operation.

ARCHITECTURE

C-2. The communications architecture is divided into the Area Common User System (ACUS), the Army Data Distribution System (ADDS), and Combat Net Radios (CNRs). ADA brigades are required by joint, combined, and operational doctrine to command and control air and missile defense operations. To accomplish this, the ADA brigade must transmit and receive the following information:

- Alerting and early warning
- Air battle control
- Command and control
- Administrative and logistics
- Targeting information from intelligence broadcasts
- Supported unit command relationship
- Liaison

DESIGN

C-3. ADA brigade communications are designed to support two major functions: engagement operations (EO) and force operations (FO). These functions are explained in the following paragraphs.

Engagement Operations

C-4. EOs includes those functions required to execute the air, missile, and counter surveillance battles. The air surveillance function establishes a correlated air picture with target types and identification. The mission control function processes commands from higher echelon units, evaluates the threat, optimizes engagement performance, monitors the outcome of engagements, and manages the employment of sensors and decoys. The attack operations support function determines the location of enemy air and missile launch sites and provides it to the C⁴I system for attack operations. The data distribution function distributes the air picture and track data. Force operations are conducted in the FDC of the CP.

Force Operations

C-5. FO include those functions required to plan, coordinate, prepare for, and sustain the total air and missile defense mission. The situation analysis function continuously collects and evaluates all available information on friendly and hostile forces, including the intelligence tasks of continuous APB and situation development. The defense planning function develops and assesses various options and produces a preferred course of action. The coordination function implements the coordination and cooperation required to develop, distribute, and execute the plan in a timely manner. The monitoring and controlling function observes and records activities taken in response to orders issued and performs alerting based on the situation. The routine staff function supports the overall battle command process. Predictive EO algorithms will use FO information from the situation analysis function as the basis for recommending or directing EO activities. The ADA brigades perform FO functions in the remainder of the CP operational cells.

COMMUNICATIONS SUPPORT

C-6. Connectivity into the ACUS is required for most ADA brigade non-EO communications. EAC ADA brigades have an organic signal support company assigned to provide mobile subscriber equipment (MSE) connectivity into the theater ACUS network. The corps ADA brigade relies upon the corps signal brigade to provide connectivity into the theater ACUS network. Required communications for an ADA brigade are identified in the following paragraphs.

ENGAGEMENT OPERATIONS DATA

C-7. The EO data is normally received via an automated data link (ADL) from a higher-level control facility. The actual control facility will be situationally dependent. For example, during forced entry operations the control facility could be non-land based. They are either an Air Force AWACS or Navy AEGIS cruiser. After establishment of a lodgment, control could change to another land based facility, either an Air Force CRC or a Marine Corps TAOC or TAOM. The data link to be used will depend upon the capability of the control facility. Data links can be established using TADIL-A, TADIL-B, or TADIL-J message formats. The TADIL-A and TADIL-J networks can be entered directly using communications equipment and HF or UHF radios located in the brigade CP. TADIL-B data links enter via a modem and an interface into the Army Common User System (ACUS) for transmission. The ADA brigade needs to pass EO data to subordinate task forces and battalions, both Patriot and SHORAD. This is accomplished by using either ATDL-1 or TADIL-B message formats using the ACUS as transmission means. [Figure C-1](#) illustrates ADA Brigade EO Data Connectivity.

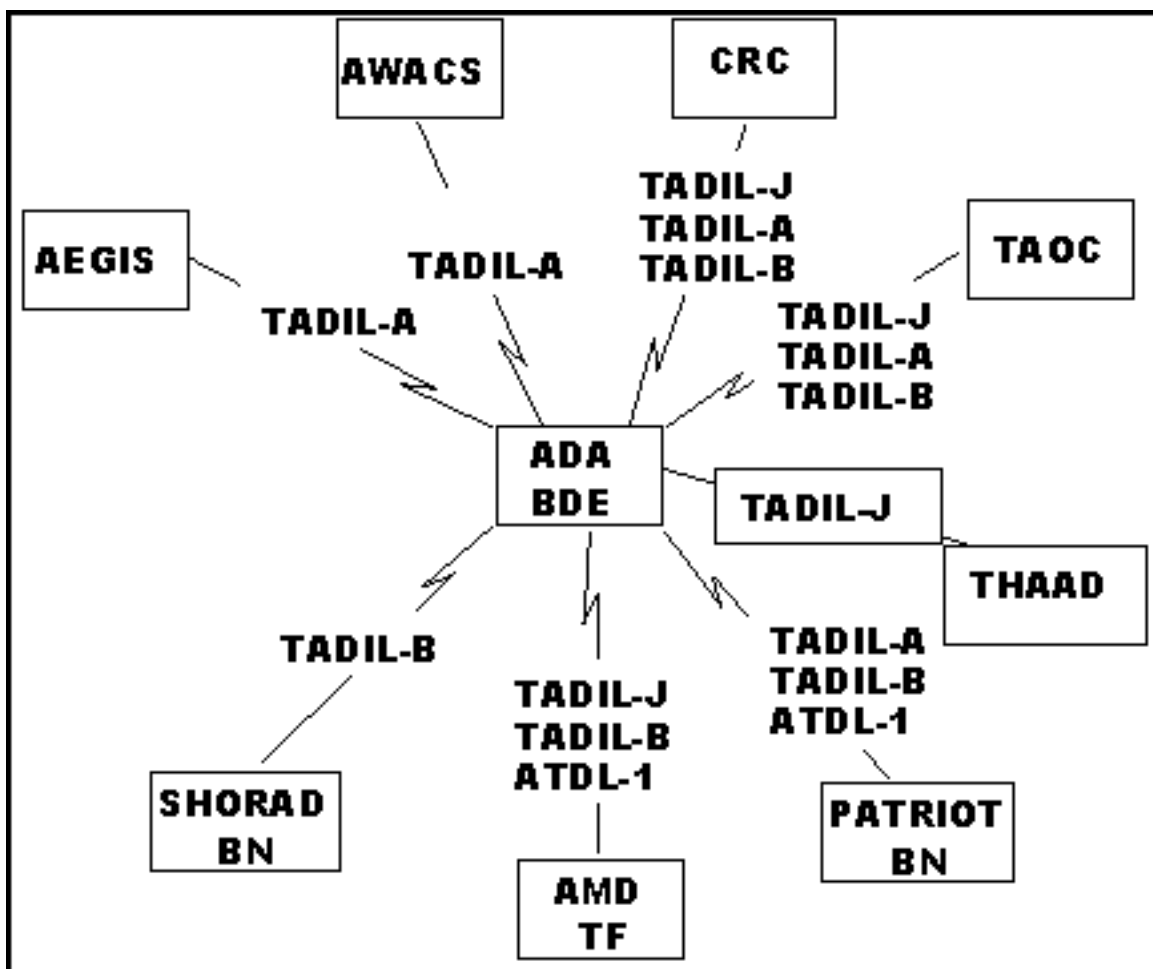

Figure C-1. ADA Brigade EO Data Connectivity

ENGAGEMENT OPERATIONS VOICE

C-8. EO voice networks are established using either HF or UHF radios for airborne or sea based control facilities and through the ACUS for other land based control facilities. The brigade FDC needs to monitor or participate in voice networks as described in the following paragraphs.

Interface coordination network

C-9. The interface coordination network (ICN) coordinates tactical weapons employment and is the C³I interface. This network most closely resembles the air defense control (ADC) network described below.

Track supervision network

C-10. The track supervision network (TSN) is used to clarify the tactical picture and assist with unit interface. This network most closely resembles the intelligence and radar reporting (IRR) network described below.

Air defense command

C-11. The air defense command (ADC) network is a conference network used by the brigade and battalion TDAs for clarifying the air picture. The FDC normally has either an AM or an FM radio backup for this network.

EARLY WARNING VOICE NETWORKS

C-12. The CP is equipped with a single channel SATCOM radio to receive TBM launch early warning directly from the theater TMD early warning network. [Figure C-2](#) illustrates the ADA Brigade EO Voice Connectivity.

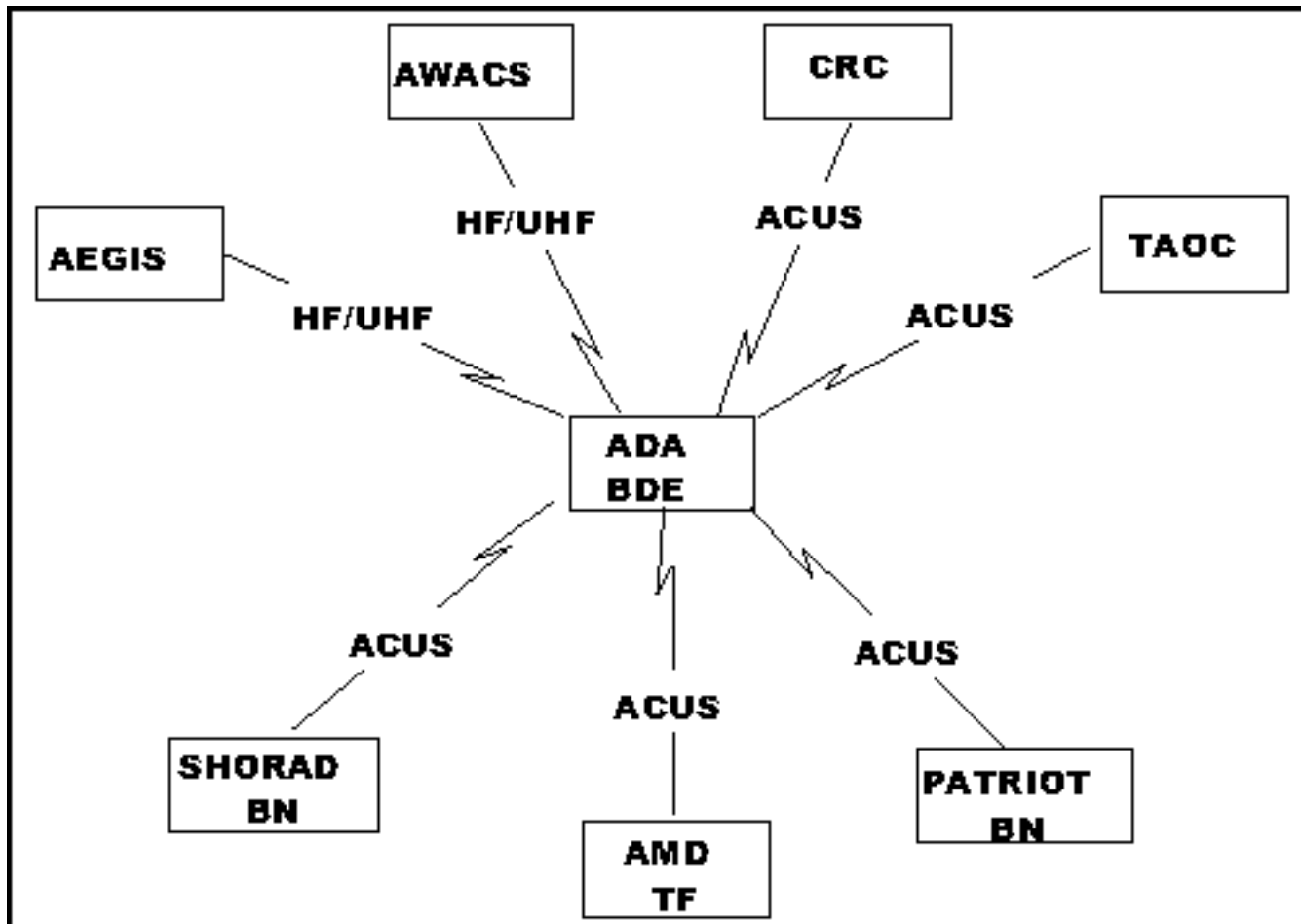

Figure C-2. ADA Brigade EO Voice Connectivity

FORCE OPERATIONS COMMUNICATIONS

C-13. FO voice and data are routed entirely over the area common user system. This consists of TRITAC and MSE communications equipment. Brigade elements are capable of calling other elements on user owned and operated communications equipment. [Figure C-3](#) illustrates the FO Voice and Data Connectivity.

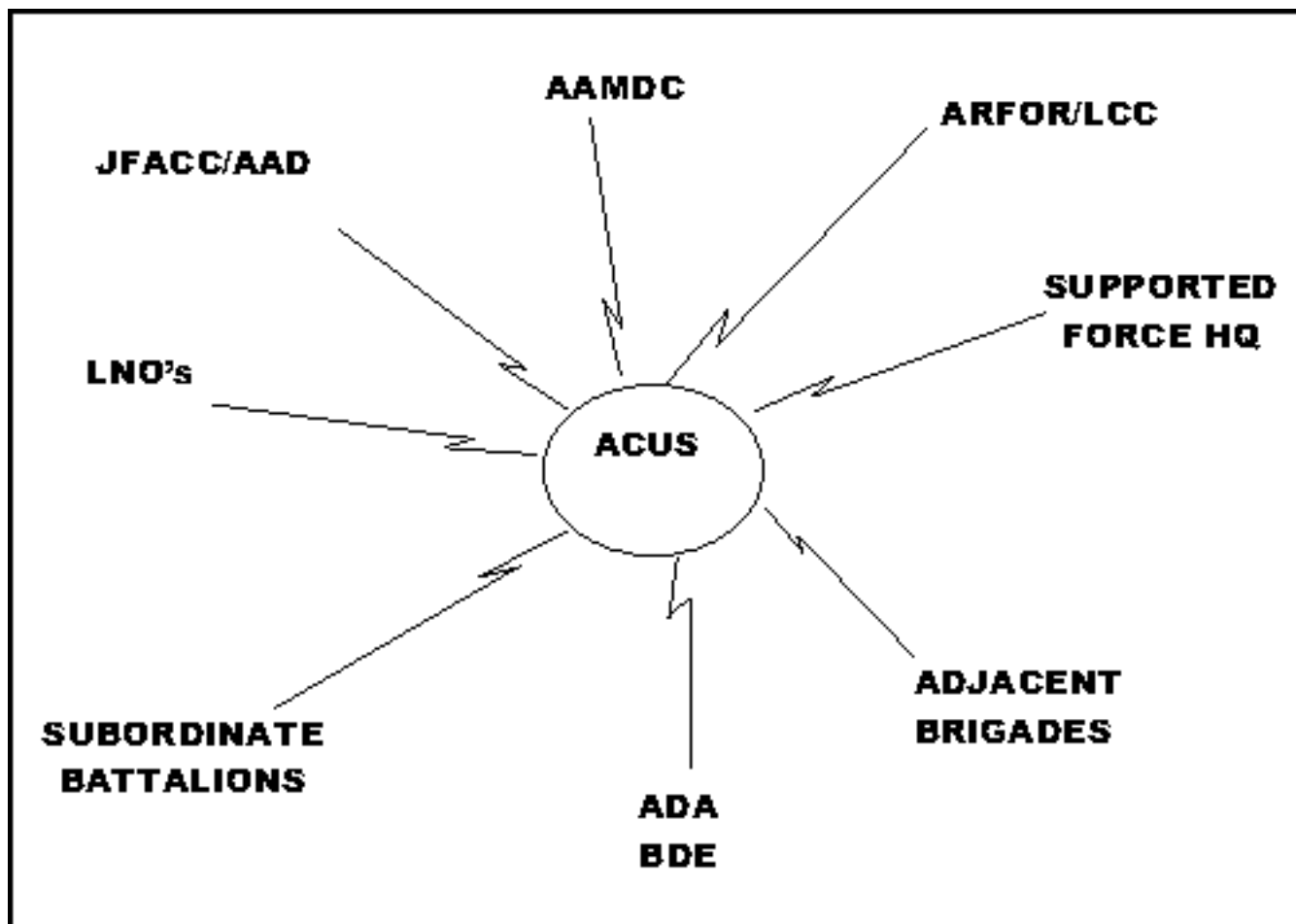

Figure C-3. FO Voice and Data Connectivity

COMPUTERS

C-14. Automation exists throughout the CP to enhance performance and promote standardization, commonality, and modularity. The CP will maximize the use of existing and planned automation in the form of common reconfigurable workstations and software modules to tailor the information processing automated decision aids for a particular function, application, or situation. Computers support the rapid fusion of data to meet the short execution timelines needed to fight the air and missile defense battle.

INTELLIGENCE

C-15. Intelligence is vital to the decision making cycle and must support friendly forces threat assessment, defense planning, force warning, and IPB functions as well as target prioritization and engagement decisions against enemy forces. The intelligence function focuses on acquiring and making information available to support brigade operations using intelligence systems, capabilities, and organizations.

C-16. The brigade will receive near-real time intelligence and early warning information

directly from the TIBS and TDDS networks via an organic commander's tactical terminal/joint tactical terminal (CTT/JTT) radio. These networks will provide information from a number of data sources both national and theater. These networks are explained in detail later in the next section.

COMMUNICATIONS SYSTEMS

C-17. The following communications systems support the brigade in accomplishing its AD mission. Some of these systems may not be available at all times.

COMMANDER'S TACTICAL TERMINAL/JOINT TACTICAL TERMINAL

C-18. The CTT/JTT provides the joint war fighter with seamless, near real-time tactical intelligence and targeting information. It provides the critical data link to intelligence centers, air and missile defense activities, fire support, and aviation nodes across all services. The CTT/JTT is capable of accessing information transmitted over the tactical reconnaissance intelligence service (TRIXS), tactical information broadcast service (TIBS), both UHF SATCOM and line-of-sight, tactical data information exchange system-B (TADIXS-B), and the TRAP data dissemination system (TDDS). The CTT/JTT is a family of receivers. The two channel AN/USR-5 radio is capable of receiving data from two networks simultaneously. The three channel AN/USC-55 (JTT/H3) is capable of operating full duplex in one network and receive only in two additional networks simultaneously. The AN/USR-6 is a receive only, three channel radio, capable of receiving from three networks simultaneously.

ENHANCED POSITION LOCATION REPORTING SYSTEM

C-19. The AN/VSQ-2 enhanced position location reporting system (EPLRS) is a secure, anti-jam, data communications system that provides ATCCS requisite data distribution at corps and lower echelons. It also provides an automated position location reporting capability in support of friendly battlefield situational awareness. EPLRS consists of two major components. The EPLRS User Unit is similar in physical characteristics to SINCGARS. The net control station EPLRS (NCS-E) is mounted on a HMMWV and is owned and operated by signal corps elements.

HAVEQUICK

C-20. The Havequick (AN/ARC 164 V) is a modular, slice constructed, solid state, 10 watt UHF transmitter/receiver that provides 7000 channels, 20 of which can be preset. It is standard equipment for the US Air Force and Army with alternate console/panel mounts for each service. The AN/ARC 164 includes the RT-1145 (10W) and RT-1146 (30W) remote transceivers, C-9533 control unit, and ID-1961 frequency/channel indicator. ACA-

218B is available as a vehicle/ground adapter. It provides plug-in operation of standard VHF and UHF airborne radios in vehicles and fixed ground stations.

IMPROVED HIGH FREQUENCY RADIO

C-21. AM improved high frequency radios (IHFR) provide long-range combat net radio (CNR) connectivity between operational elements at all echelons of the Army. IHFR radios are primarily used as back-up communications in the event that the ACUS or organization unique communications networks fail. IHFR is capable of transmitting and receiving voice and data, and must be externally secured through the use of the KY-99 Minintern COMSEC device. The IHFR replaces the US Army's AN/GRC-106 and several other AM radios. This family of radios includes the AN/PRC-104 low power (20W) manpack radio, the AN/GRC-193 high power (100-400W) vehicular radio, and the AN/GRC-213 low power (20W) vehicular radio. The IHFR has a frequency range of 2 to 20 MHz utilizing 280,000 channels in 100 MHz steps.

SINGLE CHANNEL GROUND-AIR RADIO SYSTEM

C-22. Single channel ground-air radio system (SINCGARS) is a family of VHF-FM radio sets designed to meet the Army's tactical communications requirements under the new force projection doctrine. SINCGARS is replacing the AN/PRC-77 and AN/VRC-12 series radio sets. SINCGARS is designed for simple, quick operation utilizing a 16-element keypad for push button tuning. SINCGARS is capable of short range or long-range operation for voice, frequency shift keying, or digital data communications. It can be used for single channel or in a jam-resistant frequency-hopping mode that can be changed as needed. SINCGARS has a built-in self test with visual and audio feed back.

AREA COMMON USER SYSTEM

C-23. The area common user system (ACUS) is the in-theater, tactical communications equivalent of "Ma Bell." The ACUS network is installed and operated by US Army signal brigades at the EAC and corps levels, and organic signal battalions in divisions. The ACUS consists of two families of equipment used at different levels. In the corps and division, the ACUS utilizes mobile subscriber equipment (MSE). At EAC, the ACUS utilizes tri-service tactical communications (TRITAC) equipment.

MOBILE SUBSCRIBER EQUIPMENT

C-24. Mobile subscriber equipment (MSE) is a family of communications equipment that uses a variety of multi-channel radio and switching systems to form a communications network that provides bulk-encrypted (secure), voice, data, and tactical packet network switching.

Component

C-25. The major components of the MSE network are node centers, large extension nodes (LENs), and small extension nodes (SEnS). These nodes are distributed across the battlefield and interconnected to provide connectivity between users. User owned and operated devices are used for connectivity into the MSE-ACUS. These items include the TA-1035/U, Digital nonsecure voice telephone (DNVT) with data port; the KY-68, digital secure voice telephone (DSVT) with data port; the AN/UXC-7, lightweight tactical facsimile; the AN/UGC-144, single subscriber terminal (SST) teletype; and the AN/VRC-97, mobile subscriber radio terminal (MSRT). The MSRT provides mobile secure voice into the MSE network.

Operation

C-26. MSE equipment operates at 16 kilobits per second and, other than through specifically designated interface stations, is not operationally compatible with EAC TRITAC-ACUS. This does not infer that an MSE subscriber cannot dial through the MSE network to reach a TRITAC serviced activity.

TRI-SERVICE TACTICAL COMMUNICATIONS

C-27. TRITAC is a joint communications family of equipment that uses a variety of multi-channel radio and switching systems. It forms a network that provides bulk-encrypted (secure) voice, data, and tactical packet network message switching. Line of sight and TACSAT links are used as transmission means for TRITAC.

Transmission Systems

C-28. Transmission systems include the AN/TRC-170 troposcatter system, the AN/TSC-85A, AN/TSC-93A, AN/TSC-94A, and the AN/TSC-100A satellite communications terminals.

Switching Systems

C-29. Switching systems include the AN/TYC-39 and AN/GYC-7 message switches, and the AN/TTC-39 and AN/TTC-42 circuit switches. TRITAC user owned and operated devices that facilitate connectivity to the TRITAC-ACUS include the TA/954-U digital nonsecure voice telephone (DNVT) without data port; the KY-68, digital secure voice terminal (DSVT) with data port; the AN/UXC-7, lightweight tactical facsimile; and the AN/UGC-144, single subscriber terminal (SST). A very limited number of subscribers use the AN/VRC-97, mobile subscriber radio terminal (MSRT).

TRITAC Equipment

C-30. TRITAC equipment operates at either 16 or 32 kilobits, which is selectable. They can be used with both the TRITAC and MSE networks.

JOINT TACTICAL INFORMATION DISTRIBUTION SYSTEM

C-31. Joint tactical information distribution system (JTIDS) is a high capacity, time division multiple access (TDMA) information distribution system that provides integrated communications, relative navigation, and identification capabilities. It has been developed to facilitate secure, flexible, and jam resistant data and voice transfer in real time among dispersed and mobile elements of the military services. The significant characteristic of JTIDS is the system architecture, which simultaneously interconnects all participants. The system is considered a pool of weapons, sensors, and command information that is continuously updated by each participant. The participant simultaneously taps the pool for tactical data and is provided with information and commands for force management and coordination.

C-32. The JTIDS class 2M terminal is configured for airborne, ground, and ship system applications. The receiver transmitter/transmitter contains all of the TDMA radio frequency functions plus an independent receiver/transmitter which provides an airborne traffic air control and navigation (TACAN) capability operating simultaneously with the JTIDS communications functions.

AIR DEFENSE INTERFACE

C-33. The air defense interface (ADI) provides the interfaces between analog voice and data circuits and the digital MSE network. It provides analog to digital conversion required to interface modems to the MSE network.

TACTICAL DIGITAL INFORMATION LINKS

C-34. A tactical digital information links (TADIL) is a JCS approved standardized communication link suitable for transmission of digital information. A TADIL is characterized by standardized message formats and transmission characteristics. TADILs interface two or more command and control or weapons systems via a single or multiple network architecture and multiple communication media for exchange of tactical information. Five tactical links are used: TADILs A, B, C, J, and ATDL-1.

TADIL-A

C-35. TADIL-A, Link 11, is a secure, half duplex netted digital link that provides a network for exchanging tactical data between TADIL-A subscribers at either 1364 or 2250 bits per second. It is normally operated in a roll call or polling mode. It is controlled by a net control station to exchange information between airborne, land based, and shipboard systems. It can be exchanged using either HF or UHF communications.

TADIL-B

C-36. TADIL B, Link 11B, is a secure, full duplex, point to point digital data link utilizing serial transmission frame characteristics and standard message formats at either 600, 1200, or 2400 bits per second. It can be exchanged using UHF or landline communications.

TADIL-C

C-37. TADIL C, Link 4, is an unsecured, UHF, time-division digital data link utilizing serial transmission characteristics and standard message formats at 5000 bits per second from a controlling unit to an aircraft. Information exchange can be one way (controlling unit to aircraft) or two way.

TADIL J

C-38. TADIL J, Link 16, is a secure, jam resistant, high capacity, nodeless data link which uses the JTIDS transmission characteristics and protocols conventions and message formats.

INTERIM JTIDS MESSAGE SPECIFICATION

C-39. Interim JTIDS Message Specification (IJIMS) is a secure, high capacity, jam resistant, nodeless interim specification that uses the JTIDS transmission characteristics and the protocols, conventions, and fixed length message formats defined by IJMS. IJMS information can be received by the Army's adaptable surface interface terminal (ASIT) or the JTIDS class 2M radio terminal.

ARMY TACTICAL DATA LINK-1

C-40. Army tactical data link-1 (ATDL-1) is a secure, full duplex, point to point digital data link utilizing serial transmission frame characteristics and standard message formats at a basic speed of 1200 bits per second. It is used to interconnect tactical air control systems and Army or Marine Corps tactical air and missile defense oriented systems. ATDL-1 can be exchanged using UHF, VHF, or landline communications.

INTELLIGENCE NETWORKS

C-41. The ADA brigade can benefit from other intelligence networks that may be in the theater. Some of these networks are explained in the following paragraphs.

TACTICAL INFORMATION BROADCAST SERVICE

C-42. Tactical information broadcast service (TIBS) distributes theater specific, time sensitive tactical intelligence information to operational users via secure line of sight or UHF SATCOM broadcasts. In a theater of operations, the network can accept input for retransmission from up to 10 information producers. Data producers can include JTAGS, Rivet Joint, JSTARS, AWACS, GRCS, CGS, or Trojan special purpose intelligence remote integrated terminal (TROJAN SPIRIT). While this is a theater network, information can be shared between networks giving TIBS worldwide data dissemination capabilities.

TRAP DATA DISSEMINATION SYSTEM

C-43. TRAP data dissemination system (TDDS) collects a variety of intelligence and other information from multiple worldwide sources and disseminates through a secure UHF SATCOM broadcast to authorized tactical users. TDDS provides global surveillance information for sensor cueing and integration into field user databases.

INTELLIGENCE SYSTEMS--TROJAN SPIRIT

C-44. TROJAN SPIRIT is an interim remote intelligence collection and distribution system. It consists of a mobile ground terminal that transmits and receives bulk encrypted intelligence information and data to designated subscribers. TROJAN SPIRIT is a tri-band satellite terminal capable of operating in the C, Ku, and X bands. The system receives, displays, and transmits digital imagery, weather, terrain products, templates, graphics, and text between CONUS and OCONUS bases. It also provides it to deployed forces. TROJAN SPIRIT uses CONUS-based data processing, whose database is constantly updated from multiple sources. It either broadcasts to designated users or may be "pulled" by designated users. TROJAN SPIRIT is unique to the IEW community. It is intended to augment corps and EAC.

[RDL](#)[Table of](#)[Document](#)[Download](#)[Homepage](#) [Contents](#) [Information](#) [Instructions](#)

Appendix D

Executing ADA Brigade Operations

This appendix explains how to execute the plan at brigade level. Executing the plan requires all the battle tasks of the C² combat function. As is the case with planning tools and methods, there are many paths to success. [FM 5-0](#), nevertheless, outlines some basic principles, which should be inherent in executing tactical operations. This appendix outlines some of those. In executing AMD operations, the goal is to make the best staff recommendation and the best command decision within the time available. In planning the operation, the commander visualizes how the battle will unfold and arrive at his intent for the operation. In executing operations to meet the commander's intent, the commander and his staff are reliant on information to cue the commander as to when to decide and what to decide. Therefore, execution of ADA brigade operations involves effective management of combat information.

COMBAT INFORMATION BASICS

D-1. There exists an infinite amount of detail concerning events on the battlefield. Improving battlefield C⁴I capability enables ADA CPs to gather more and more of it. Combat information is that information which can affect the unit mission. It can be very tangible (e.g. the location of a specific enemy unit) or intangible (the effectiveness of enemy doctrine and training). It can be very perishable or can be a constant of the ongoing campaign. Failure to detect, process, and present combat information for a decision is equivalent to bypassing a large enemy unit. Battle staffs must rehearse, train, and war game operations to identify potential combat information requirements and means to process them rapidly.

TYPES OF COMBAT INFORMATION

D-2. The commander identifies his information requirements during the planning process. These include priority intelligence requirements (PIRs), commander's critical information requirements (CCIRs), and essential elements of friendly information (EEFI). There are three types of information which contribute to the overall situation awareness in the ADA CP. The type of combat information affects how it is refined and processed by the ADA

brigade staff.

Routine Information

D-3. Routine information is the standard, repetitive information essential for daily unit operations. It is used in the development of staff estimates and is useful in identifying trends and potential problems. It is not time sensitive and is normally passed through staff channels on a recurring basis as prescribed in the unit SOP. Routine information must be relevant to the mission; otherwise, it is not combat information. The battle staff must closely review all routine information requirements against this standard to ensure that subordinate units are not being burdened with nonessential reporting requirements.

Critical Information

D-4. This information directly affects current operations and is thus time sensitive. It is situational dependent but largely predictable based on established branches and sequels. The commander articulates what information he must know in terms of CCIRs. These may be published in the OPORD and are applicable only to the commander who establishes them. CCIRs are used by the staff to develop recommended PIRs, which affect how the commander sees the enemy. They also affect development of EEFI, which identify priority combat information items concerning friendly operations that must be denied to the enemy. The specification of critical information focuses the staff on its information management tasks and the commander on his critical decisions.

Exceptional Information

D-5. Exceptional information is specific, immediate, and vital information that directly affects the success of the current operation. It is usually tied to an unforeseen event, which either presents an opportunity for success or poses a grave threat to the operation. It is automatically a CCIR and must be handled first by the commander before operations can continue. This information must get to the commander as soon as possible by any means available. By definition, it cannot be anticipated; therefore, a key training task for battle staffs is identifying and processing exceptional combat information.

REFINING COMBAT INFORMATION

D-6. The commander has four basic questions concerning combat information. The ADA brigade DCO is responsible as the chief of staff to supervise the staff effort in answering these questions.

What is happening

D-7. The answer to this question initiates the decision process. To the extent that the information is triggered by a predictable event, the AMD plan should identify it as a decision point. The AMD decision support matrix described in [Appendix B](#) thus becomes an essential tool in managing combat information. Combat information is not always tied to a discrete battlefield event; however, it can often become apparent as a trend. Reporting requirements, combat AARs, and operations summaries are crucial to capturing these trends so that they may be acted on.

What does it mean

D-8. Raw data does not become useful as combat information until its impact on the operation is assessed. Sometimes this impact is obvious to the commander; other times, the impact only becomes apparent with staff analysis.

How, when and by whom should it be accomplished

D-9. This is the course of action development and analysis process. Sometimes it is accomplished in minutes by the commander himself; other times, it requires detailed staff analysis.

PROCESSING COMBAT INFORMATION

D-10. The staff processes combat information and presents it to the commander for decision. This requires information to be reported to the CP, distributed to all elements that it may affect, prioritized for analysis, and maintained as a combat information product. Procedures for this must be detailed in unit SOPs and battle staff training programs.

Reporting Information

D-11. The ADA brigade SOP must specify the format and elements of information to be reported. Reporting requirements must be based on a close analysis of the combat information requirements of the brigade so as not to overburden subordinate CPs.

Prioritizing Information Management

D-12. Both the brigade reporting requirements and the CP internal SOP must establish priorities for acting on information. These should tie the types of information outlined above to specific reporting timelines.

Distributing Information

D-13. Decentralized execution relies on decentralized combat information. The ADA brigade establishes standard distribution schemes for each item of potential combat information. The staff must apply the "who else should know" standard to all information. It is acceptable for the battle staff to over inform on all but the most sensitive information. The advanced automation support of the ADA brigade and battalion CPs will significantly improve this capability.

Information Products

D-14. Processed combat information must be packaged for decision. Routine information can be disseminated to affected headquarters and stored for future use. CCIR products should be continually and immediately available to the commander and should preferably be displayed in the CP. Exceptional information is not normally processed, but given straight to the commander.

ADA BRIGADE INFORMATION MANAGEMENT

D-15. Specific procedures for management of combat information will depend on the desires of the commander and the situation of the unit. These procedures must be planned in advance and trained in command post exercises and staff drills. COMSEC regulations describe the procedures for originating and using codes.

REFINING INFORMATION

D-16. The combat information plan drives the staff activity in the ADA brigade CP. Information received must be processed and promptly acted upon.

STAFF BRIEFINGS

D-17. A key event within the CP for synchronizing the information flow is the update briefing to the commander. This briefing is not an administrative staff meeting, but a highly structured battle staff drill. Its purpose is to update the commander on the status of his CCIR, PIR, and EEFI, and to answer his five questions regarding them.

STAFF DRILLS

D-18. Refinement of routine information is an ongoing staff process. Critical and exceptional information requires streamlined and rehearsed staff procedures to provide the commander with his decision options. Standardized and rehearsed staff drills ensure this. In many cases, these procedures will be abbreviated staff estimates. Within each battle staff section, however, there must also be standardized actions so that information does not

languish. [Figure D-1](#) outlines a sample of a staff drill for the brigade S4.

S1/S4 DRILL #1: EMERGENCY REFIT	
Conditions. A Patriot firing battery or Avenger platoon is RED for supply or maintenance.	
DRILL. X-Hour = time the information is received at the brigade CP. The brigade S4 is responsible to execute this drill. Corrective action should be underway within 15 minutes.	
<u>NLT TIME</u>	<u>ACTION</u>
X+ 5 MIN.	Does battalion need help? What are the resupply or cross level options?
X+ 10	Inform brigade CDR and S3. Provide recommendation and get guidance.
X+ 15 MIN.	Initiate the action and monitor through execution.

Figure D-1. Sample Staff Drill

SHIFT CHANGE BRIEFING

D-19. Shift changes in the CP are information "battle hand-offs". They must be accomplished quickly, completely, and with a minimum of confusion. If necessary, shift change times should be staggered within staff sections so that CP operations are not interrupted. Shift change briefings must be structured to cover all CCIRs, the current situation, and any changes to the plan or commanders intent.

INFORMATION DISPLAYS

D-20. The purpose of information displays in the CP is to keep the commander continuously aware of the status of his information requirements and to focus the staff effort in providing this information. The layout of CP displays and the format of each

display should be organized in close coordination with the commander to ensure that his information requirements are met. Information should be directly based on PIRs, CCIRs, mission guidance, and the status of mission accomplishment. Routine information should only be displayed by exception. Information should be readable from where the commander sits. Wherever possible, CP displays should show combat information products, rather than raw information. For example, unit status should be displayed in terms of combat effectiveness ratings (RED, AMBER, GREEN, BLACK) based on predetermined criteria rather than raw data such as missiles on hand or POL gallons on hand.

OPERATIONS/INTEL CELL DISPLAYS

D-21. Command is normally effected from the S2/S3 cell within the ADA brigade CP. All information affecting the current operation must be available in the S2/S3 cell, though many items may be tracked in more detail in the S1/S4 cell or the FDC. S2/S3 cell displays should include CCIRs related to the unit mission, the current battlefield geometry, the status of mission execution, and the status of force protection/ survivability.

Mission Status

D-22. Mission displays should show the unit essential tasks and the intent of the brigade commander and higher headquarters one and two levels up. For general reference, the designation of the orders in effect should be listed, particularly when the higher headquarters publishes numerous fragmentary orders. Orders displays include the order number of the current brigade and higher headquarters OPOD, FRAGO, ACO, and SAM tactical order (as applicable). DST generated by higher headquarters, adjacent headquarters, and the brigade itself are key execution documents and should be displayed. A DST graphically portrays how unit or battlefield activities are connected and where decisions are required.

Battlefield Geometry

D-23. These displays should show the commander spatial relationships which affect how he fights the brigade. First among these should be a terrain map. Command and control graphics should be displayed as necessary, including ground control measures, FSCL, boundaries, and objectives. ADA brigade units should be displayed on the map to the level at which they are tracked in the CP. These are usually the HIMAD fire unit and SHORAD platoon. The enemy situation should be displayed on the operations map wherever possible. Command posts and adjacent units that affect ADA brigade operations should be displayed on the operations map.

Execution Status

D-24. These displays show the progress of current operations and should include unit operational status, mission changes, decisions made or pending, adjacent/higher unit information, significant activities, and actions working. The DST developed by the brigade planners becomes a key execution tool for the S2/S3 cell. The S2/S3 cell may display an execution matrix to show how the DST is being executed as planned or modified. The execution matrix can serve not only as an updated DST, but also as a record of significant events. In the example below, key execution events are portrayed visually over a 24-hour period, including when units moved, arrived, became operational, and had significant AMD engagements or air battles. [Figure D-2](#) depicts an execution matrix.

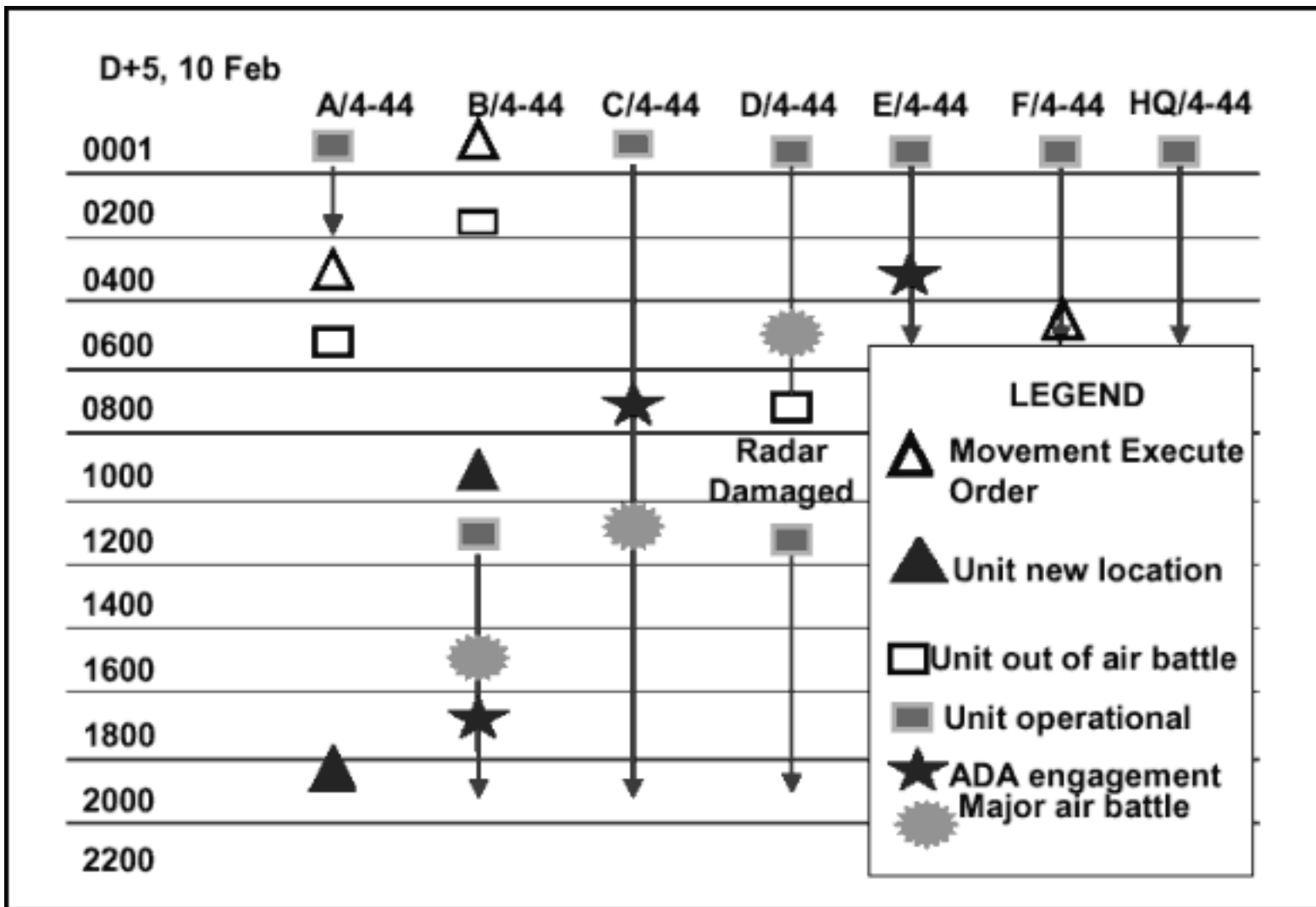

Figure D-2. ADA Brigade Execution Matrix

Force Protection Status

D-25. Force protection displays should show the status of units, capabilities, and events that affect the survivability status or force protection posture of the ADA brigade. Examples include the MOPP status, rear battle threat level, and NBC events.

S1/S4 DISPLAYS

D-26. Sustainment is the focus of the S1/S4 cell. As in the S2/S3 cell, information displays in the S1/S4 cell are tied to the primary effort of weapons system sustainment, unit sustainment, and soldier sustainment.

Sustainment Status

D-27. These displays track the sustainment status of weapon systems, critical items, and units. Sustainment status displays should focus on the six logistics functions of FUEL-ARM-FIX-MAN-MOVE and soldier sustainment. Specific information (e.g., numbers of missiles on hand) should be displayed by exception. Movement coordination, including air movement and airlift, involves significant coordination with many support agencies. Movement status displays should track the progress of this coordination. Personnel status displays should orient on the bottom line personnel status by unit. KIA/WIA events and priority shortages may also be displayed. Significant recent CSS events should be displayed.

CSS Geometry

D-28. The S1/S4 cell should have a tactical map that shows spatial relationships affecting transportation and resupply operations. Critical CSS nodes, routes, and facilities may be displayed.

[RDL](#)[Table of](#)[Document](#)[Download](#)[Homepage](#)[Contents](#)[Information](#)[Instructions](#)

Glossary

A²C² Army airspace command and control

AA avenue(s) of approach; assembly area

AAA air avenue(s) of approach

AADC area air defense commander. Within an overseas-unified command, subordinate unified command, or JTF, the commander will assign overall responsibility for air defense to a single commander. Normally, this will be the AFCC. Representation from the other service components involved will be provided, as appropriate, to the AADC headquarters.

AAMDC Army air and missile defense command

AAW anti-air warfare

AAR after action review

AASLT air assault

ABCS Army battle command system

ABMOC air battle management operations center. Old name for the SHORAD organization that managed the ADA air battle and provided early warning. Now known as the AD Tactical Operations (AD TAC OPS) section in the FAAD system.

ABT air breathing threat

AC	active component
A/C	aircraft
ACA	airspace control authority
ACC	air component commander
ACE	analysis and control element
ACE	aviation combat element
ACM	airspace control measures
ACO	airspace control order
ACP	airspace control plan
ACR	armored cavalry regiment
ACUS	Army common user system

active air defense Direct defensive action taken to destroy, nullify or reduce the effectiveness of hostile air and missile threats against friendly forces and vital assets. It includes the use of aircraft, air defense weapons, electronic warfare, and other available weapons. See also air defense.

active defense Operations that protect selected assets and forces from attack by destroying TM airborne launch platforms and/or TMs in flight. Active defense includes those actions that mitigate the effectiveness of targeting and delivery systems through EW against remote or onboard guidance systems.

AD Air defense. All defensive measures designed to destroy attacking enemy aircraft or missiles in the Earth's envelope of atmosphere, or to nullify or reduce the effectiveness of such attack. See also active air defense; aerospace defense; passive air defense.

ADA	air defense artillery. Ground-based surface-to-air weapons, including guns and surface-to-air missiles and support equipment, for engaging air targets.
ADC	air defense control
ADDS	Army data distribution system
ADE	air defense element
ADI	air defense interface
ADIZ	air defense identification zone
ADL	automatic data link
ADOA	air defense operations area
ADOCS	automated deep operations coordination system
ADPE	automated data processing equipment
ADSI	air defense systems integrator
ADTOC	air defense tactical operations center
ADW	air defense warnings
AEGIS	A totally integrated shipboard weapon system that combines computers, radars, and missiles.
AFATDS	advanced field artillery tactical data system
AFCC	Air Force component commander
AFFOR	Air Force forces

AG	Adjutant General
AGCCS	Army global command and control system
AGM	attack guidance matrix
air battle management	A fundamental task or air defense command and control and airspace management which encompasses the principles for the control and coordination of both tactical air and ground-based air defense resources. Air battle management is exercised through positive and procedural methods.
air corridor	A restricted air route of travel specified for use by friendly aircraft and established for the purpose of preventing friendly aircraft from being fired upon by friendly forces.
air interdiction	Air operations conducted to destroy, neutralize, or delay the enemy's military potential before it can be brought to bear effectively against friendly forces, at such distances from friendly forces that detailed integration of each air mission with the fire and movement of friendly force is not required.
airspace control	A service provided in the combat zone to increase operational effectiveness by promoting the safe, efficient, and flexible use of airspace. Airspace control is provided in order to permit greater flexibility of operations, while authority to approve, disapprove, or deny combat operations is vested only in the operational commander.
airspace management	The coordination, integration, and regulation of the use of airspace of defined dimensions.
air strike	An attack on specific objectives by fighter, bomber, or attack aircraft on an offensive mission.
air superiority	That degree of dominance in the air battle of one force over another that permits the conduct of operations by the former and its related land, sea, and air forces at a given time and place without prohibitive interference by the opposing force.

air supremacy	That degree of air superiority wherein the opposing air force is incapable of effective interference.
AIS	automated information system
ALCM	air-launched cruise missile
ALERT	attack and launch early reporting to theater
alert	A warning signal of a real or threatened danger, such as an air attack; to forewarn; to prepare for action.
Allocation	The translation of the apportionment into total number of sorties by aircraft type available for each operation or task.
alternate position	The position given to a weapon unit, or individual to be occupied when the primary position becomes untenable or unsuitable for carrying out its task. The alternate position is located so that the weapon can continue to fulfill its original task.
AM	amplitude modulation
AMD	air and missile defense
AMDCOORD	air and missile defense coordinator
AMDTF	air and missile defense task force
AMDPCS	air and missile defense planning and control system
AMDWS	air and missile defense work station
ANBACIS	automated nuclear biological and chemical information system
AO	area of operation
AOAP	Army oil analysis program

AOP	air operations plan
AOC	air operations center. The principle air operations installation (land- or ship-based) from which all aircraft and air warning functions of tactical air operations are controlled.
AOI	area of interest
AOR	area of responsibility
APB	(acquisition/approved) program baseline.
APOD	air ports of debarkation
AR	Army regulation
ARFOR	Army forces
ARM	Anti-radiation missile. A missile which homes passively on a radiation source. See also guided missile.
ARSOF	Army special operations force
ASAS	All Source Analysis System
ASCC	Army service component commander
ASG	area support groups
ASIT	adaptable surface interface terminal
ASL	authorized stockage list
ASOC	air support operations center
ASP	ammunition supply point

ATACMS	Army tactical missile system
ATC	Army tactical command
ATCCS	Army tactical command and control system
ATDL-1	Army Tactical Data Link-1
ATO	air tasking order
attach	The placement of units or personnel in an organization where such placement is relatively temporary. Subject to limitations imposed by the attachment order, the commander of the formation, unit, or organization receiving the attachment will exercise the same degree of command and control therefore as he does over units and persons organic to his command. However, the responsibility for transfer and promotion of personnel will normally be retained by the parent formation, unit, or organization.
attack	An offensive action characterized by fire and maneuver and culminating in a violent assault or, in an attack by fire, in the delivery of intensive direct fires from an advantageous position. Its purpose is to direct a decisive blow at the enemy to hold him, destroy him in place, or force him to capitulate.
attack operations	Offensive actions intended to destroy and disrupt enemy TM capabilities before, during, and after launch. The objective of these operations is to prevent the launch of TMs by attacking each element of the overall system, including such actions as destroying launch platforms, RSTA platforms, C ² nodes, and missile stocks and infrastructure.
AUTL	Army universal task list
AVN	aviation
AWACS	airborne warning and control systems

- basic load (Ammunition)** That quantity of non-nuclear ammunition that is authorized and required by each service to be on hand a unit to meet combat needs until resupply can be accomplished. It is expressed in rounds, units, or unity of weight as appropriate.
- BCD** battlefield coordination detachment. The Army liaison element collocated with the AOC which process land forces' requests for tactical air support, monitors and interprets the land battle situation for the AOC, and provides the necessary interface for the exchange of current intelligence and operational data.
- BDA** battle damage assessment
- BDAR** battlefield damage assessment and repair
- Bde** brigade
- BDU** battle dress uniform
- BFDC** brigade fire direction center
- BII** basic issue items
- BM** ballistic missile
- BMO** ballistic missile organization
- bn** battalion
- boundary** In land warfare, a line by which areas of responsibility between adjacent units/formations are defined.

- C²** command and control. The exercise of authority and direction by a properly designated commander over assigned forces in the accomplishment of the mission. Command and control functions are performed through an arrangement of personnel, equipment, communications, facilities, and procedures employed by a commander in planning, directing, coordinating, and controlling forces and operations in the accomplishment of the mission.
- CAS** Close Air Support. Air action against hostile targets which are in close proximity to friendly forces and which require detailed integration of each air mission with the fire and movement of those forces.
- C²W** command and control warfare
- C³** command, control, and communications
- C³I** command, control, communications, and intelligence
- C⁴I** command, control, communications, computers, and intelligence
- CA** combined arms
- CAAD** corps area air defense
- CADE** corps air defense element
- CAPS** commander's analysis and planning system
- CAS** close air support
- CCIR** commanders critical information requirements
- CDR** Commander
- C / E** communications / electronics

CG	commanding general
CGS	command & general staff
CH	common hardware
CHS	common hardware and software
CIC	combat intelligence cell
CINC	commander in chief
CJCS	Chairman of the Joint Chiefs of Staff
CJTF	commander joint task force
CM	cruise missile
CMMC	corps materiel management center
CNR	combat net radio
COA	courses of action
COCOM	combatant command
COEI	components of end item
COMARFOR	commander of Army forces
COMINT	communications intelligence
COMMEL	communications electronics
COMMZ	communications zone

COMSEC	communications security. The protection resulting from all measures designed to deny authorized persons information of value which might be derived from the possession and study of telecommunications, or to mislead unauthorized persons in their interpretation of the results of such possession and study.
command	The authority that a commander in the military service lawfully exercises over subordinates by virtue of rank or assignment. Command includes the authority and responsibility for effectively using available resources and for planning the employment of organizing, directing, and coordinating, and controlling military forces for the accomplishment of assigned missions. It also includes responsibility for health, welfare, morale, and discipline of assigned personnel.
CONUS	continental United States
continuity	Continuity implies the responsibility of ensuring an operation is not effected by an interruption of support or by unforeseen events.
control	Authority that may be less than full command exercised by a commander over part of the activities of subordinate or other organizations.
C of S	Chief of Staff
COSCOM	corps support command
CP	command post A unit's or sub unit's headquarters where the commander and the staff perform their activities. In combat, a unit's or sub unit's headquarters is often divided into echelons; the echelon in which the unit or sub unit is located or from which he operates is called a command post.
CRC	control and reporting center
CRE	control and reporting element
CRP	control and reporting post

CS	combat support. Fire support and operational assistance provided to combat elements. Includes artillery, air defense artillery, aviation (less air cavalry and attack helicopter), engineer, military police, signal, military intelligence, and chemical.
CSH	combat support hospital
CSR	controlled supply rate
CSS	combat service support. The essential logistic functions, activities, and tasks necessary to sustain all elements of an operating force in an area of operations. Combat service support includes but is not limited to the assistance provided operating forces primarily in the fields of administrative services, chaplain services, civil affairs, finance, legal service, health services, military police, supply, maintenance, transportation, construction, troop construction, acquisition and disposal of real property, facilities engineering, topographic and geometric engineering functions, food service, graves registration, laundry, dry cleaning, bath, property disposal, and other logistic services.
CSSCS	combat service support control system
CTA	common table of allowances
CTAPS	contingency theater air control system automated planning system
CTL	candidate target list
CTOC	corps tactical operations center
CTT	commander's tactical terminal
cueing	Providing specific and timely position data with tentative identification of aircraft within a designated range of a fire unit.
CZ	combat zone

DA	Department of the Army
DAADC	deputy area air defense commander
DAL	defended asset list
DAO	division ammunition officer
DCA	defensive counterair. The protection of assets from air attack through both direct defense and destruction of the enemy's air attack capacity in the air.
DCG	Deputy Commanding General
DCO	deputy commanding officer
DCSOPS	deputy chief of staff for operations
defend	A mission assigned to a unit which requires it to destroy an attacking enemy force or stop it from penetrating the assigned sector or battle position. Sub units of the defending unit may have such missions as defend, delay, or counterattack.
DEFCON	defense readiness conditions
delay	A mission which requires a force to trade space for time without losing freedom to maneuver or risking penetration or being bypassed. The delaying force may attack, defend, ambush, raid, or use any other tactic necessary to accomplish the mission.
delaying operation	An operation in which a force under pressure trades space for time by slowing down the enemy's momentum and inflicting maximum damage on the enemy without, in principle, becoming decisively engaged.
deliberate attack	A type of offensive action characterized by preplanned coordinated employment of firepower and maneuver to close with and destroy or capture the enemy.

DEW division early warning

DISCOM division support command

DISNET defense secure network

div division

DNVT digital non-secure voice terminal

DOCC deep operations coordination cell

DOS days of supply

DS direct support

DSM decision support matrix

DST decision support template

DSU direct support unit

DSVT digital subscriber voice terminal

EA electronic attack

EAC echelon above corps

EAP emergency action plan

ECM electronic countermeasures. That division of electronic warfare involving actions taken to ensure friendly effective use of the electromagnetic spectrum despite the enemy's use of electronic warfare.

ECCM	electronic counter-counter measure. That division of electronic warfare involving actions taken to prevent or reduce an enemy's effective use of the electromagnetic spectrum.
ECP	entry control plan
EDRE	emergency deployment readiness exercises
EEFI	essential elements of friendly information
ELINT	electronic intelligence
EMCON	emission control
engage	In air defense, a fire control order used to direct or authorize units and/or weapon systems to fire on a designated target.
engagement area	killing area or zone. An area in which a commander plans to force the enemy to concentrate so as to destroy him with conventional weapons.
EO	electro-optical
EOB	enemy order of battle
EP	electronic protection
EPLRS	enhanced position location reporting system
EW	electronic warfare. Military action involving the use of electromagnetic energy to determine, exploit, reduce, or prevent hostile use of the electromagnetic spectrum and action which retains friendly use of the electromagnetic spectrum.
F	frequency/Fahrenheit
FA	field artillery

FAAD	forward area air defense
FAADS	forward area air defense system
FAADC²I	forward area air defense command, control, and intelligence
FAADC³I	forward area air defense command, control, communications, and intelligence
FACP	forward air control points
FAD	force/activity designator
FARP	forward arming and refueling point. A temporary facility organized, equipped, and deployed by an aviation unit commander and normally located closer to the area of operation than the aviation unit's combat service area to provide fuel and ammunition necessary for the employment of helicopter units in combat. The forward arming and refueling point permits combat aircraft to rapidly refuel and rearm simultaneously.
FAX	facsimile terminal
FDC	fire direction center
FDDM	fire direction data manager
FDRP	first destination release point
FDS	fire direction section
FEZ	fighter engagement zone
FFIR	friendly forces information requirements
FID	foreign internal defense

- fire and maneuver** A tactical technique, usually an extension of bounding overwatch, used once contact with the enemy is gained. One element moves while another provides a base of fire.
- fix** Actions taken to prevent enemy from moving any part of his forces from a specific location and or for a specific period of time by holding or surrounding them to prevent their withdrawal for use elsewhere.
- FLOT** forward line of own troops. A line which indicates the most forward positions of friendly forces in any kind of military operation at a specific time.
- FM** field manual/frequency modulation
- FMSP** foreign military sales program
- FO** force operations
- FRAGO** fragmentary order. An abbreviated form of an operation order, usually issued on a day-to-day basis, that eliminates the need for restating information contained in a basic operation order. It may be issued in sections.
- FSB** forward support battalion
- FSCL** fire support coordination line
- FSE** fire support element. A functional element of a force command post that provides centralized targeting, coordination, and integration of fires delivered on surface targets by fire support mains under the control of or in support of the force. This element is staffed from the field artillery headquarters or field artillery staff section of the force and representatives of other fire support means.
- FU** fire unit
- FW** fixed-wing

G2	Assistant Chief-of-Staff, Personnel
G3	Assistant Chief-of-Staff, Intelligence
G4	Assistant Chief-of-Staff, Logistics
G5	Assistant Chief-of-Staff, Civil-Military Operations
GALES	generic area limitation environment system
GCCS	global command and control system
GMT	guided missile transporter
GPS	global positioning system
GRCS	guard rail common sensor
GS	general support
GSR	general support reinforcing
GSSB	GS supply base
H	Hawk
hasty attack	In land operations, an attack in which preparation time is traded for speed in order to exploit an opportunity.
HE	high explosive
HF	high frequency
HHB	headquarters and headquarters battery
HHC	headquarters and headquarters company

HIDACZ	high density aircraft control zone
HIMAD	high-to-medium-altitude air defense
HMMWV	high mobility multipurpose wheeled vehicle
hostile criteria	Description of conditions under which an aircraft or vehicle may be identified as hostile for engagement purposes.
HPTL	high priority target list
HQ	headquarters
HUMINT	human intelligence
HVT	high value target
IADS	integrated air defense system
IBS	integrated broadcast service
ICAC²	integrated combat airspace command and control
ICE	initial coordination element
ICBM	intercontinental ballistic missile
ICN	interface coordination network
ICO	interface control officer
ICW	interrupted continuous wave
ID	identification
IEW	intelligence and electronic warfare

IFF	identification, friend or foe. A system using electromagnetic transmission which equipment carried by friendly forces automatically responds, for example, by emitting pulses, thereby distinguishing themselves from enemy forces.
IHFR	improved high frequency radio
IIR	imagining infrared radar
IJMS	interim JTIDS message specification
IMETP	international military education and training program
IMETS	integrated meteorological system
IMINT	imagery intelligence
IMMP	information management modernization plan
indirect fire	Fire delivered on target that is not itself used as a point of aim for the weapons or the director.
insertion	Placement of troops and equipment into an operational area in airmobile operations; the placement of observation posts, patrols, or raiding parties wither by helicopter or parachute.
INTSUM	intelligence summary
interdict	To isolate or seal of an area by any means; to deny use of a route or approach; to prevent, hinder, or delay the use of an area or route by enemy forces.
I-PAWS	interim pager alert warning system

IPB	intelligence preparation of the battlefield. A continuous, integrated, and comprehensive analysis of the effects of terrain, weather, and enemy capabilities on operations. Using overlays, graphic displays, and templating techniques, the IPB process increases the accuracy and timeliness of the intelligence available to the commander. It should start well before combat operations begin.
IR	infrared
IRBM	intermediate range ballistic missile
IRCM	infrared countermeasures
IRR	intelligence and radar reporting
ISE	intermediate support element
ISR	Intelligence, surveillance, and reconnaissance
JAOC	joint air operations center
jamming	The deliberate radiation, reradiation, or reflection of electromagnetic energy to prevent or degrade the receipt of information by receiver. It includes communications jamming and non-communications jamming.
JCS	Joint Chiefs of Staff
JDN	joint data network
JEZ	joint engagement zone
JFACC	joint force air component commander
JFC	joint force commander
JFLCC	joint force land component commander

JFMCC	joint force maritime component commander
JFNCC	joint force naval component commander
JFSOCC	joint forces special operations component commander
JIADS	joint integrated air defense system
JICO	joint interface control officer
JIPTL	joint integrated prioritized target list
JOA	joint operations area
JP	joint publication
JRA	joint rear area
JRAC	joint rear area commander
JSOA	joint special operation area
JSOTF	joint special operations task force
JSTARS	joint surveillance and target attack radar system
JTAGS	joint tactical ground station
JTCB	joint targeting coordination board
JTF	joint task force
JTIDS	joint tactical information distribution system

JTMD	joint theater missile defense. The integration of joint force capabilities to destroy enemy theater missiles in flight or prior to launch or to otherwise disrupt the enemy's theater missile operations through an appropriate mix of mutually supportive passive missile defense; active missile defense; attack operations; and supporting command, control communications, computers, and intelligence measures. Enemy theater missiles are those that are aimed at targets outside the continental United States.
JTOC	jump tactical operations center
JTT	jump tactical terminal
J-WARN	joint warning
JZ	joint zone
KIA	killed in action
KILLSUMS	kill summaries
km	kilometer
LAD	latest arrival date
LAR	logistics assistance representatives
LCC	land component commander. The designated senior land commander in a joint force who exercises command and control of all assigned land forces. Depending on the operational environment and the composition of the forces assigned, the LCC may be the commander of the theater army, army group, field army, or corps. Based upon the joint force commander's guidance, the LCC develops his concept of operations, assigns missions, and allocates resources. He supports subordinate units by conducting joint planning and coordination required to implement their schemes of maneuver.
LCU	launcher control unit

LD	line of departure
LENs	large extension nodes
liaison	That contact or intercommunication maintained between elements of military forces to ensure mutual understanding and unity of purpose and effort.
LIF	logistics intelligence file
linkup	A meeting of friendly ground force (such as when an advancing forces reaches an objective area previously seized by an airborne or air assault force, when an encircled element breaks out to rejoin friendly forces, or when converging maneuver forces met).
LNO	liaison officer
LOC	lines of communications
LOGPAC	logistical package. A daily resupply of normally Class I, III, and V as well as medical and ADA peculiar items to maneuver elements. LOGPACs are organized in the battery field trains or the field trains of the supported maneuver force.
LOS	line-of-sight
LR	long range
LRC	logistics readiness center
LRP	logistics release point
LZ	landing zone
Main attack	The principle attack or effort into which a commander throws the full weight of the offensive combat power at his disposal. An attack directed against the chief objective of the campaign or battle.

MANPADS	man-portable air defense system
MARFOR	marine forces
MASH	mobile Army surgical hospital
MBA	main battle area. That portion of the battlefield in which the decisive battle is fought to defeat the enemy. For any particular command, the main battle area extends rearward from the forward edge of the battle area to the rear boundary of the command's subordinate units.
MCC	movement control center
MCS	maneuver control system
MCPS	modular command post system
MDCOORD	missile defense coordinator
METT-T	mission, enemy, terrain, troops, and time available
METT-TC	mission, enemy, terrain and weather, troops, time available, and civil considerations
MG	machine gun
MI	military intelligence
MIA	missing in action
MLRS	multiple-launch rocket system
MMC	material management center
MOPP	mission oriented protective posture
MP	military police

movement to contact	An offensive operation designed to gain initial ground contact with enemy or to regain lost contact.
MRE	meals ready-to-eat
MRO	material release order
MRR	minimum risk route. Temporary routes of flight recommended for fixed-wing aircraft use, prescribing the minimum known hazards to low-flying aircraft transiting the tactical operations area.
MSE	mobile subscriber equipment
msl	missile
MSR	main supply route
MSRT	mobile subscriber radio terminal
MSTS	multiple source tactical system
MTI	moving target indicator
MTOE	modified tables of organization and equipment
MTW	major theater war
mutual support	That support which units render each other against an enemy, because of their assigned tasks, their position relative to each other and to the enemy, and their inherent capabilities.
NAI	named areas of interest
NATO	North Atlantic Treaty Organization
NBC	nuclear, biological and chemical

NBCRS	NBC reconnaissance system
NCA	national command authority
NCC	network control center
NCO	noncommissioned officer
NEO	noncombatant evacuation operations
NG	National Guard
NIPRNET	non-classified internet protocol router network
NOTAM	notice to airman
NSN	national stock number
O & I	operations and intelligence
OB	order of battle
OCA	offensive counterair. An operation mounted to destroy, disrupt, or limit enemy air power as close to its source as possible.
OCIE	organizational clothing and individual equipment
OCOKA	Observation, cover, obstacles, key terrain, and avenues of approach
OCONUS	outside the continental United States
OIC	officer in charge
OOTW	operations other than war

OPCOM	Operational command. The authority granted to a commander to assign missions or tasks to subordinate commanders, to deploy units, to reassign forces, and to retain or delegate operational and/or tactical control as may be deemed necessary. It does not of itself include responsibility for administration of logistics. May also be used to denote the forces assigned to a commander.
OPCON	operational control. Transferable command authority which may be exercised by commanders at any echelon at or below the level of unified or specified combatant commands. It normally provides full authority to organize commands and forces and to employ those forces as the commander in operational control considers necessary to accomplish assigned missions. Operational control does not, in and of itself, include authoritative direction for logistics or matters of administration, discipline, internal organization, or unit training.
OPFAC	operational facilities
OPLAN	operation plan. A plan for a single or series of connected operations to be carried out simultaneously or in succession. It is usually based upon stated assumptions and is the form of directive employed by higher authority to permit subordinate commanders to prepare supporting plans and orders. The designation "plan" is usually used instead of "order" in preparing for operations well in advance. An operation plan may be put into effect at a prescribed time, or on signal, and then becomes the operation order.
OPORD	operation order. A directive issued by a commander to subordinate commanders for the purpose of effecting the coordinated execution of an operation.
OPSEC	operational security
OPTEMPO	operational tempo
ORF	operational ready float

overwatch	A tactical technique in which one element is positioned to support the movement of another element with immediate direct fire; the tactical role of an element positioned to support the movement of another element with immediate direct fire.
PAC-3	Patriot advanced capability-3
PALS	Patriot automated logistics system
passage point	A place where units will pass through one another either in an advance or withdrawal. It is located where the commander desires subordinate units to physically execute a passage of lines.
passive air defense	All measures, other than active air defense, taken to minimize the effectiveness of hostile air and missile threats against friendly forces and vital assets. These measures include camouflage, deception, dispersion, and the use of protective construction. (JP 1-02)
passive defense	Operations which provide essential individual and collective protection for friendly forces, population centers, and critical assets. The principal measures used to accomplish passive defense are tactical warning, reducing targeting effectiveness, reducing vulnerability, and recovery and reconstitution. (JP 3-01.5)
PBO	property book officer
PERSCOM	Personnel Command
PERSSVCCMD	Personnel Services Command
PGIP/T	predicted ground impact point/time
PIR	priority intelligence requirements.
PL	phase line.
PLL	prescribed load list

PLRS	position locating and reporting system
PLT	platoon
POD	port of debarkation
POE	port of embarkation
POL	petroleum, oil and lubricants
POMCUS	pre-positioned material configured in unit sets
positive control	A method of airspace control that relies on positive identification, tracking, and director of aircraft within an airspace, conducted with electronic means by an agency having this authority and responsibility therein. (JP 1-02)
POW	prisoner of war
PPDL	point-to-point data link
PRC	Peoples Republic of China
procedural control	A method of airspace control that relies on a combination of previously agreed and promulgated orders and procedures. (JP 1-02)
PTL	primary target line
PZ	pick-up zone
R	regiment
RADC	region air defense commander
RAOC	rear area operations center

RAP	recognized air picture
RC	reserve component
RCS	radar cross section
Rds	rounds
RECCE	reconnaissance
RISTA	reconnaissance, intelligence, surveillance and target acquisition
ROC	rear operations center
ROE	rules of engagement. Directives issued by competent military authority which delineate the circumstances and limitations under which forces will initiate and/or continue combat engagements with other forces encountered. In air defense, directives that delineate the circumstances under which weapons may fire at an aircraft. The right of self-defense is never denied. (JP 1-02)
RRP	replacement receiving point
RSOI	Reception, staging, onward movement, & integration
RSR	required supply rate
RSTA	reconnaissance, surveillance, and target acquisition
R/T	receiver/transmitter
RW	rotary-wing
S1	Personnel Officer
S2	Intelligence Officer

S3	Operations Officer
S4	Logistics Officer
S5	Civil Affairs Officer
SA	situational awareness
SAAFR	standard-use Army aircraft flight route
SAB	(same/subject) separate armored brigade
SAM	surface-to-air missile
SAR	synthetic aperture radar
SATCOM	satellite communications
SATP	Security Assistance Training Program
SB	special bulletin
SEAD	suppression of enemy air defenses. That activity which neutralized, destroys, or temporarily degrades enemy air defenses in a specific area by physical attack and/or electronic warfare.
SEC	sections
SECDEF	Secretary of Defense
SEN	small extension nodes
SHORAD	short range air defense. A family of ADA weapon systems that provided very low-to-low altitude air defense.
SHORADEZ	short range air defense engagement zone

SFOD	Special Forces operational detachment
SIGINT	signals intelligence
SIGO	signal officer
SIGSEC	signal security
SIPRNET	secret internet protocol router network
SINCGARS	single channel ground and airborne radio system
SJA	staff judge advocate
SLBM	sea-launched ballistic missile
SOCCE	special operations command and control element
SOCOORD	special operations coordinator
SOE	states of emission
SOF	special operations force
SOP	standard operating procedures
SOR	states of readiness
SPOD	sea ports of debarkation
SSA	supply support activity
SST	single subscriber terminal
STACCS	standard theater Army command and control system

STANAG	Standardization Agreement
SUCCESS	synthesized UHF computer controlled sub-system
support area	A designated area in which combat service support elements, some staff elements, and other elements locate to support a unit.
surveillance	The systematic observation of aerospace, surface or subsurface areas, places, persons, or things, by visual, natural, electronic, photographic, or other means.
SWA	southwest Asia
TA	theater Army
TAADCOM	Theater Army Air Defense Command
TAADCOORD	theater Army air defense coordinator
TAAMDCOORD	theater army air and missile defense coordinator
TAC	Tactical
TACAN	traffic air control and navigation
TACC	tactical air command center
TACDAR	tactical data and reporting
TACON	tactical control
TACS	theater air control system
TACSAT	tactical satellite
TADIL	tactical digital information link

TADIXS-B	tactical data information exchange system-B
TAFT	technical assistance field teams
TAI	target areas of interest
TAMMC	Theater Army material management Center
TAOC	tactical air operations centers
TAOM	tactical air operations module
TAS	target acquisition system
task organization	A temporary grouping of forces designed to accomplish a particular mission. Task organization involves the distribution of available assets to subordinate control headquarters by attachment or by placing assets indirect support or under the operational control of the subordinate.
TASM	tactical air-to-surface missile
TBM	theater ballistic missile
TD	tactical director
TDA	tactical director assistant
TDDS	tactical data distribution system
TDSS	TRAP data distribution system
TDS	tactical data system
TDMA	time division multiple access
TEL	transporter erector launcher

TERCOM	terrain contour matching
TF	task force
TGO	terminal guidance operations
THAAD	theater high altitude area defense
TIBS	tactical information broadcast service
TM	theater missile. A missile, which may be a ballistic missile, a cruise missile, or an air-to-surface missile (not including short-range, non-nuclear, direct fire missiles, bombs, or rockets such as Maverick or wire-guided missiles), whose target is within a given theater of operation. (JP 1-02)
TMD	theater missile defense
TMDA	time division multiple access
TOC	tactical operations center. An element within the main command post which consists of those staff activities involved in sustaining current operations and in planning future operations.
TOE	tables of organizations and equipment
TPFDD	time phased force deployment data
TPFDL	time phased force deployment list
TRADOC	US Army Training and Doctrine Command
TRAP	tactical receive equipment and related applications
TRITAC	tri-service tactical communications
TRIXS	tactical reconnaissance intelligence service

TROJAN SPIRIT	Trojan special purpose intelligence remote integrated terminal
TSC	theater signal company
TSM	tactical surface missiles
TSN	track supervision network
TST	time sensitive target
TV	television
UAV	unmanned aerodynamic vehicles. An air vehicle that is remotely or automatically controlled.
UAV-SR	unmanned aerial vehicle-short range
UBL	unit basic load
UCMJ	Uniform Code of Military Justice
UHF	ultra high frequency
UIC	unit identification code
UND	urgency of need designator
US	United States
USA	United States of America
USAF	United States Air Force
USCENTCOM	United States central command
USMC	United States Marine Corps

USR	unit status report
USSR	Union of Soviet Socialist Republics
VHF	very high frequency
VRC	vehicular radio communications
WAD	weapons alert designator
WARNO	warning order
WCS	weapons control status. One of three degrees of weapons fire control used by a commander to control fires of air defense weapons: weapons free, weapons hold, and weapons tight.
weapons free	In air defense, a weapon control status used to indicate that weapons systems may be fired at any target not positively identified as friendly.
weapons hold	In air defense, a weapon control status used to indicate that weapons systems may be fired only in self-defense or in response to a formal order.
weapons tight	In air defense, a weapon control status used to indicate that weapons systems may be fired only at targets identified as hostile.
WEZ	weapon engagement zone. In air defense, airspace of defined dimensions within which the responsibility for engagement normally rests with a particular weapon system.
WFZ	weapons free zone
WIA	wounded in action
WIN	warfighter information network

WMD	weapons of mass destruction
WOTS	worldwide origin and threat system
WSRO	weapons system replacement operations
WWMCSS	worldwide military command and control system



[RDL](#)

[Table of](#)

[Document](#)

[Download](#)

[Homepage](#)

[Contents](#)

[Information](#)

[Instructions](#)

Bibliography

- AR 310-25. Dictionary of United States Army Terms. 15 October 1983.
- AR 310-50. Authorized Abbreviations and Brevity Codes. 5 November 1985.
- AR 385-64. Ammunition and Explosives Safety Standards. 23 May 1987.
- AR 710-20. Supply Policy Below the Wholesale Level. 17 July 1990.
- AR 750-1. Army Material Maintenance Policies. 1 August 1994.
- DA Form 1156. Casualty Feeder Report. June 1966.
- DA Form 2028. Recommended Changes to Publications.
- DA Form 2404. Equipment Inspection and Maintenance Worksheet. April 1979.
- DA Form 2407. Maintenance Request. June 1993.
- DA Form 581. Request for Issue or Turn-In of Ammunition. August 1989.
- DA Pamphlet 385-1. Small Unit Safety Officer/NCO Guide. 22 September 1993.
- FM 2-01.3. Intelligence Preparation of the Battlefield. 8 July 1994.
- [FM 3-0](#). Operations. 14 June 1993.
- FM 3-01. US Army Air Defense Operations. 15 June 2000.
- FM 3-01.64. FAAD Battalion and Battery Operations. 5 June 1997.
- FM 3-01.8. Combined Arms for Air Defense. 1 June 1999.

FM 3-01.80. Visual Aircraft Recognition. 20 July 1993.

FM 3-01.85. Patriot Battalion and Battery Operations. 21 February 1997.

FM 3-09.12. Field Artillery Target Acquisition. 25 September 1994.

FM 3-09.30. Observed Fire. 16 July 1991.

[FM 3-19.30](#). Physical Security. 1 March 1979.

FM 3-35. Mobilization, Deployment, Redeployment, and Demobilization. 28 October 1982.

[FM 3-50](#). Decisive Force: The Army in Theater Operations. 31 May 1995.

FM 3-61. Public Affairs. 30 May 1997.

FM 3-97.13. River Crossing Operations. 26 January 1998.

FM 3-100.1. Army Airspace Command and Control in a Combat Zone. 7 October 1987.

FM 3-100.15. Corps Operations. 29 October 1996.

FM 3-100.16. Army Operational Support. 31 May 1995.

FM 4-0. Combat Service Support. 3 October 1995.

FM 4-01. Army Transportation Services in a Theater of Operations. 3 October 1995.

FM 4-01.14. Army Water Transport Operations. 7 June 1985.

FM 4-01.3. Movement Control in a Theater of Operations. 9 February 1999.

FM 4-01.30. Army Motor Transport Units and Operations. 14 March 1980.

FM 4-02. Health Service Support in a Theater of operations. 1 March 1991.

FM 4-02.285. Treatment of Chemical Agent and Conventional Military Chemical Injuries. 22 December 1995.

FM 4-02.50. Prevention and Medical Management of Laser Injuries. 8 August 1990.

- FM 4-02.55. Planning for Health Service Support. 9 September 1994.
- FM 4-02.6. Medical Evacuation in a Theater of Operations. 14 April 2000.
- FM 4-20.1. General Supply in a Theater of Operations. 20 April 1993.
- FM 4-20.21. Water Supply in Theaters of Operations. 11 July 1990.
- FM 4-20.64. Mortuary Affairs Operations. 28 February 1986.
- FM 4-03. Petroleum Supply in a Theater of Operations. 16 February 1999.
- FM 4-30.1. Munitions Support in the Theater of Operations. 20 March 1998.
- FM 4-30.31. Recovery and Battlefield Damage Assessment and Repair. 3 October 1995.
- FM 4-93.3. Combat Service Support Operations-Theater Army Area Command. September 1984.
- FM 5-0. Staff Officers' Field Manual: Staff Organization and Operations. 31 May 1997.
- FM 6-02.45. Signal Support to Theater Operations. 30 June 1999.
- FM 6-22. Army Leadership. 31 August 1999.
- FM 6-24.33. Communications Techniques Electronic Counter-countermeasures. July 1990.
- FM 6-99. Operational Terms and Symbols. 30 September 1997.
- JP 1-02. DOD Dictionary of Military and Associated Terms. 23 March 1994.
- JP 3-01. Joint Doctrine for Countering Air and Missile Threats. 19 October 1999.
- JP 3-01.5. Doctrine for Joint Theater Missile Defense. 22 February 1996.
- JP 3-13.1. Joint Doctrine for Command and Control Warfare (C²W). 7 February 1996.
- JP 3-52. Doctrine for Joint Airspace Control in a Combat Zone. 22 July 1995.
- [JP 5-0](#). Doctrine for Planning Joint Operations. 13 April 1995.

JP 3-56.1. Command and Control for Joint Air Operations. 14 November 1994.

STANAG 2014. Operations Orders, Annexes to Operations Orders, and Administrative/Logistics Orders.

STANAG 2019. Military Symbols.

STANAG 2034. Land Forces Procedures for Allied Supply Transactions.

STANAG 2041. Operations Orders, Tables and Graphs for Road Movement.

STANAG 3700. NATO Tactical Air Doctrine-ATP-33 (B).

STANAG 3736. Offensive Air Support Operation-ATP-27.



[RDL](#) [Table of](#) [Document](#) [Download](#)

[Homepage](#) [Contents](#) [Information](#) [Instructions](#)

FM 3-01.7
31 OCTOBER 2000

By Order of the Secretary of the Army:

ERIC K. SHINSEKI
General, United States Army
Chief of Staff

Official:

JOEL B. HUDSON
Administrative Assistant to the
Secretary of the Army
0030715

DISTRIBUTION: Active Army, Army National Guard, and U.S. Army Reserve: To be distributed in accordance with the initial distribution number 115835, requirements for FM 3-01.7.