

CHANGE

NO. 1

HEADQUARTERS
DEPARTMENT OF THE ARMY
Washington D. C., 10 August 1988

TRUCK, CHASSIS: 2-1/2 TON, 6X6, M44A1 AND M44A2 (MULTIFUEL);
TRUCK, CARGO: M35A1, M35A2, M35A2C, M36A, M36A1, M36A2, M36A2C;
TRUCK, TANK, FUEL: M49A1C, M49A2C;
TRUCK, TANK, WATER: M50A1, M50A2, M50A3;
TRUCK, VAN, SHOP: M109A2, M109A3;
TRUCK, REPAIR SHOP: M185A2, M185A3;
TRUCK, TRACTOR: M275A1, M275A2;
TRUCK, DUMP: M342A2;
TRUCK, PIPELINE CONSTRUCTION: M756A2;
TRUCK, EARTHBORING AND POLESETTING: M764

LO 9-2320-209-12-1, 1 April 1976, is changed as follows:

1. Remove old pages and insert new pages as indicated below.
2. New or changed material is indicated by a vertical bar in the margin of the page and by a vertical bar adjacent to the change.

Remove Pages

3 and 4
21 and 22
31 and 32

Add Pages

3 and 4
21 and 22
31 and 32

By Order of the Secretary of the Army:

Official:

CARL E. VUONO
General, United States Army
Chief of Staff

R.L. DILWORTH
Brigadier General, & United States Army
The Adjutant General

Distribution:

To be distributed in accordance with DA Form 12-38, Operator's and Unit Maintenance requirements for Truck, Multifuel, 2 1/2-ton 6x6 M44A1 and M44A2 series.

☆ U.S. GOVERNMENT PRINTING OFFICE: 1994 - 300-721 (00306)

LUBRICATION ORDER

LO 9-2320-209-12-1

30 APRIL 1983

This copy is a reprint which includes current pages from Change 1.

(Supersedes LO 9-2320-209-12/1

30 September 1976 and

portion of LO 9-2320-209-12

15 October 1971 applicable to multifuel powered vehicles)

TRUCK, CHASSIS: 2-1/2 TON, 6X6, M44A1 AND M44A2 (MULTIFUEL);
TRUCK, CARGO: M35A1, M35A2, M35A2C, M36A, M36A1, M36A2, M36A2C;
TRUCK, TANK, FUEL: M49A1C, M49A2C;
TRUCK, TANK, WATER: M50A1, M50A2, M50A3;
TRUCK, VAN, SHOP: M109A2, M109A3;
TRUCK, REPAIR SHOP: M185A2, M185A3;
TRUCK, TRACTOR: M275A1, M275A2;
TRUCK, DUMP: M342A2;
TRUCK, PIPELINE CONSTRUCTION: M756A2;
TRUCK, EARTH BORING AND POLESETTING: M764

REFERENCE: TM 9-2320-209-10-HR, TM 9-2320-209-10-1, TM 9-2320-209-10-2, TM 9-2320-209-10-3, TM 9-2320-209-10-4, TM 9-2320-209-20-1, TM 9-2320-209-20-2-1, TM 9-2320-20-2-2, TM 9-2320-209-20-3-1, TM 9-2320-209-20-3-2, TM 9-2320-209-20-3-3, TM 9-2320-209-20-3-4, TM 9-2320-209-20P.

Intervals (on-condition or hard time) and the related man-hour times are based on normal operation. The man-hour time specified is the time you need to do all the services prescribed for a particular interval. On-condition (OC) oil sample intervals shall be applied unless changed by the Army Oil Analysis Program (AOAP) laboratory. Change the hard time interval if your lubricants are contaminated or if you are operating the equipment under adverse operating conditions, including longer-than-usual operating hours. The hard time interval may be extended during periods of low activity. If extended, adequate preservation precautions must be taken. Hard time intervals will be applied in the event AOAP laboratory support is not available.

Refer to TB 43-0002-87 for BFS conversion procedures.

Clean fittings before lubricating. Clean parts with drycleaning solvent (SD) type II or equivalent. Dry before lubricating. Dotted arrow points indicate lubrication required on both sides of equipment.

The lowest level of maintenance authorized to lubricate a point is indicated by one of the following symbols: Operator/Crew (C); and Organizational Maintenance (O).

Relubricate after fording.

REPORTING ERRORS AND RECOMMENDING IMPROVEMENTS

You can help improve this lubrication order. If you find any mistakes or if you know of a way to improve the procedures, please let us know. Your letter or DA form 2028 (Recommended Changes to Publications) should be mailed directly to: Commander, U.S. Army Tank-Automotive Command, ATTN: DRSTA-MB, Warren, Michigan 48090. A reply will be furnished directly to you.

TA 252437

OIL CAN POINTS

Every 1,000 miles (1,600 km) or monthly, lubricate: door, tailgate, windshield and side panel hinges, locks and latches, transfer case and power takeoff shift linkage, clutch and brake pedal linkage, handbrake shoe outer pin, handbrake control, winch propeller shaft shear pin, rear winch and power-divider control lever linkages, earth boring machine operating handle linkage, outrigger control lever linkage, discharge valve control lever pivot pin, and tailgate control lever linkage with seasonal grade OE. Coat roller sheave spindle bars with thin layer of GAA. For vehicles in storage, oil and operate the handbrake lever at 30-day intervals to allow for penetration of lubricant between the handbrake lever shaft and housing.

DO NOT LUBRICATE

Springs, leaves, clutch release bearing, generator, alternator, starter, and shock absorbers.

LUBRICATE AT TIME OF ASSEMBLY BY DIRECT SUPPORT (DS) AND GENERAL SUPPORT (GS) PERSONNEL

Clutch pilot bearing, clutch release bearing carrier, speedometer flexible shaft, revolving platform bearings, and lineguide roller shaft bearings.

GENERAL NOTES

General notes are located on pages 30 through 33.

NOTE

All lubrication capacities are approximate (approx).

Military symbols for lubricants are found in general notes number 21.

Hours in the interval column refer to hours of operation. When two intervals are shown, lubricate at the interval which occurs first.

TA 252438

-KEY-

LUBRICANTS	CAPACITIES	EXPECTED TEMPERATURES			INTERVALS
		Above 15°F (Above -10°C)	+40° to -15°F (+5° to -25°C)	+40° to -65°F (+5° to -55°C)	
OE/HDO-LUBRICATING OIL ICE TACTICAL (MIL-L-2104) (SEE NOTE 14) OEA-LUBRICATING OIL ARCTIC (MIL-L-46167) OIL CAN POINTS MAIN DRIVE IDLER GEAR HOUSING CRANKCASE	5 qts. (4.7 l) 22 qts. (21 l) w/filter	OE/HDO 30	OE/HDO 10*	OEA	OC-On condition (AOAP) C/MR-Change gear lubricant only when required by mainte- nance repair action, or if contaminated by water or other foreign materials. D- Daily W- Weekly M- Monthly Q- Quarterly S- Semiannually 1- 1,000 miles (1,600 km) 3- 3,000 miles (4,800 km)/ 3 months/ 300 hours 6- 6,000 miles (9,600 km) 12- 12,000 miles (19,000 km) D/8 HR-Daily or after 8 hours of operation, whichever comes first. M/100 HR-Month- ly or after 100 hours of operation, whichever comes first. W/25 HR-Weekly or after 25 hours of operation, whichever comes first. 3/S-3,000 miles (4,800 km) or semiannually (6 months), whichever comes first.
CRANE HYDRAULIC TANK EARTH BORING CLUTCH AND BRAKE DUMP BODY HYDRAULIC RESERVOIR	18 pts. (17.0 l)	OE/HDO 10*			
GO-LUBRICATING OIL GEAR MULTIPURPOSE (MIL-L-2105) WINCH END BORING FRAME HOUSING WINCH WORM HOUSING TRANSMISSION (W/PTO) STEERING GEAR WORM GEAR HOUS- ING (REAR WINCH) WORM GEAR HOUS- ING (FRONT WINCH) POWER DIVIDER SPEED REDUCER BORING CASE END FRAME HOUSING DIFFERENTIAL (3) TRANSFER CASE	1 pt. (0.47 l) 1-1/4 pts. (0.6 l) 8-1/2 pts. (4.0 l) 3-1/8 pts. (1.5 l) 7 pts. (3.3 l) 2-3/4 pts. (1.30 l) 3-1/2 qts. (3.3 l) 2 pts. (0.9 l) 10 qts. (9.5 l) 1-7/8 pts. (0.89 l) 6 qts. ea. (5.7 l) 7 qts. (6.6 l)	GO 80/90	GO 80/90	GO 75	

FOR ARCTIC OPERATION, REFER TO FM 9-207

* If OEA lubricant is required to meet the temperature ranges prescribed in the KEY, then the OEA lubricant is to be used in place of OE/HDO 10 lubricant for all temperature ranges.

—KEY— (Cont'd)

LUBRICANTS	CAPACITIES	EXPECTED TEMPERATURES				FOR ARCTIC OPERATION, REFER TO FM 9-207	INTERVALS
		Above 15°F (Above -10°C)	+40° to -15°F (+5° to -25°C)	+40° to -65°F (+5° to -55°C)			
GAA-GREASE, AUTOMOTIVE AND ARTILLERY (MIL-G-10924) FRONT WHEEL UNIVERSAL JOINT	2 lbs. ea. (0.91 kg)	ALL TEMPERATURES					
BFS**-BRAKE FLUID, SILICONE, AUTOMOTIVE, ALL WEATHER, OPERATIONAL AND PRESERVATIVE (MIL-B-46176) BRAKE MASTER CYLINDER		ALL TEMPERATURES					
CW-LUBRICATING OIL, CHAIN WIRE ROPE, EXPOSED GEAR (VV-L-751) WINCH WIRE ROPE		ABOVE +80°F(27°C)	80° to 30°F (27° to -1°C)	30° to -30°F (-1° to -34°C)	-30° to -65°F (-34° to -55°C)	X	
		CW-IIC	CW-IIB	CW-IIA	GO 75		

** See TB 43-0002-87 for conversion procedures from HB to BFS.

TOTAL MAN-HOURS

	OC	C/MR	D	W	M	Q	S	1,000	3,000	6,000	12,000	D/ 8 HR	M/ 100 HR	W/ 25 HR	3/5
TRUCK, CARGO: M35A1, M35A2, M35A2C, M36A2	3.0	3.7	0.6			1.2	3.7	3.5	1.2	6.5	3.2				1.5
TRUCK, TANK, FUEL: M49A1C, M49A2C	3.0	3.7	0.7			1.2	3.7	3.5	1.2	6.5	3.2				1.5
TRUCK, TANK, WATER: M50A1, M50A2, M50A3	3.0	3.7	0.7			1.2	3.7	3.5	1.2	6.5	3.2				1.5
TRUCK, VAN SHOP: M109A2, M109A3;	3.0	3.7	0.6			1.2	3.7	3.5	1.2	6.5	3.2				1.5
TRUCK, REPAIR SHOP: M185A2, M185A3															
TRUCK, TRACTOR: M275A1, M275A2	3.0	3.7	0.6			1.2	3.7	4.0	1.2	6.5	3.2				1.5
TRUCK, DUMP: M342A2	3.0	3.7	0.8			1.2	4.0	3.5	1.2	7.5	3.2				2.0
TRUCK, PIPELINE CONSTRUCTION: M756A2	3.0	5.0	1.2		1.0	1.2	5.2	3.6	1.2	6.5	3.2				1.5
TRUCK, EARTH BORING AND POLESETTING: M764	3.0	5.5	1.6	1.0	0.5	1.2	5.2	3.6	2.4	8.5	3.2	1.0	1.0	1.5	1.5
WINCH, FRONT MOUNTED							2.5	0.5	0.5	0.1	1.5				

NOTE

The man-hours shown above have been established on an individual vehicle basis and, accordingly, are not applicable at maintenance facilities where production line methods are employed. TA 252440

INTERVAL • LUBRICANT

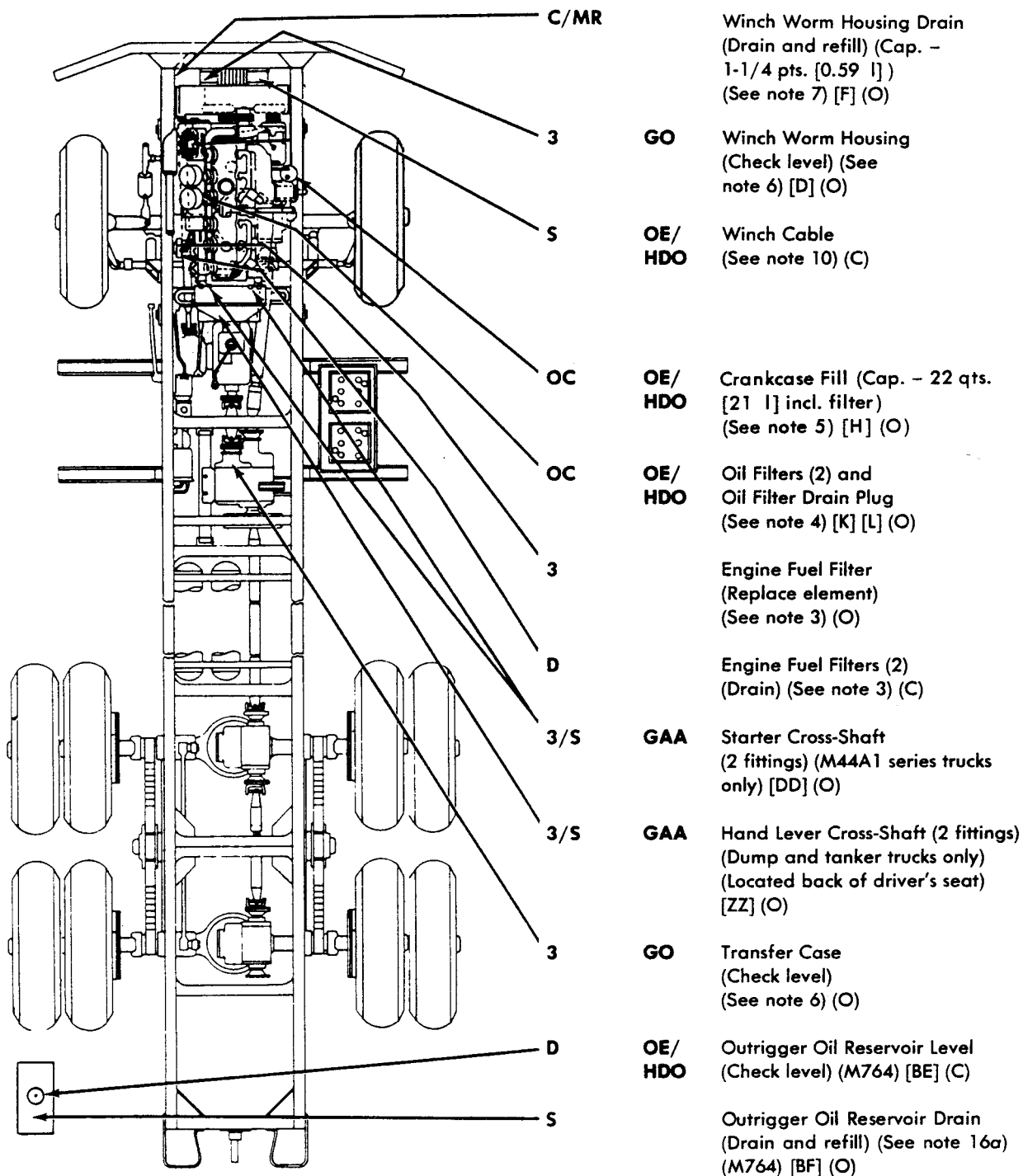

CHASSIS — M44A1, M44A2

NOTE

Letters in brackets after lubrication entries refer to localized views. See pages 21 through 29.

TA 252441

INTERVAL • LUBRICANT

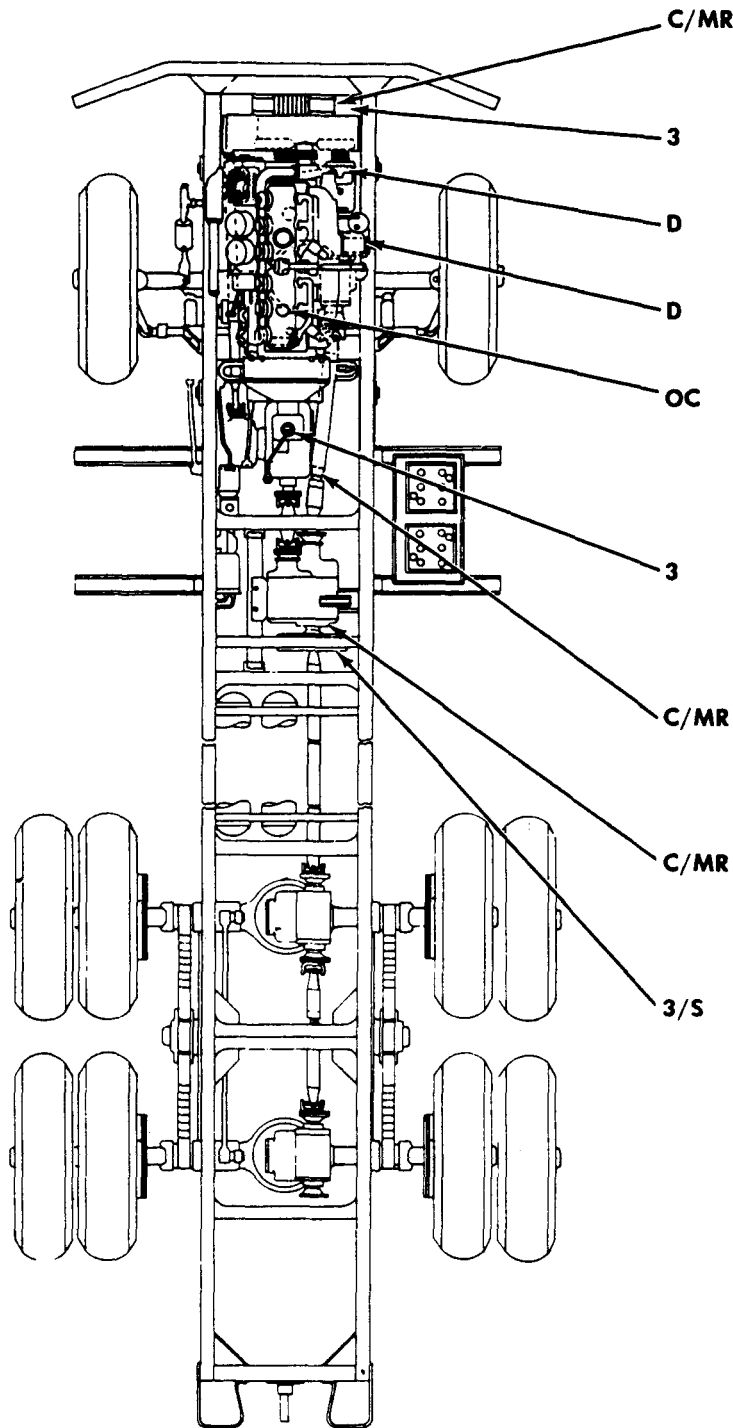

- C/MR** Winch End Boring Frame Housing Drain (Drain and refill) (Cap. - 1 pt. [0.47 l]) [E] (See note 7) (O)
- 3** **GO** Winch End Boring Frame Housing (Check level) (See note 6) [D] (O)
- D** Primary Fuel Filter (Drain) (See note 3) (C)
- D** Oil Level Indicator (Check level) [J] (C)
- OC** Engine Crankcase Drain (2) (Change oil) (See note 5) (O)
- 3** **GO** Transmission Fill and Level (Check level) (Remove plug to check level, and reinstall plug) (See note 6) (O)
- C/MR** Transmission Drain (Drain and refill) (Cap. - 8-1/2 pts. [4.0 l] w/PTO) (See note 6) (O)
- C/MR** Transfer Case Drain (Drain and refill) (Cap. - 7 qts. [6.6 l]) (See note 6) (O)
- 3/S** **GAA** Handbrake Lever and Shoe Anchor Pins (4 fittings sparingly) (O)

CHASSIS — M44A1, M44A2

NOTE

Letters in brackets after lubrication entries refer to localized views. See pages 21 through 29.

TA 252442

INTERVAL • LUBRICANT

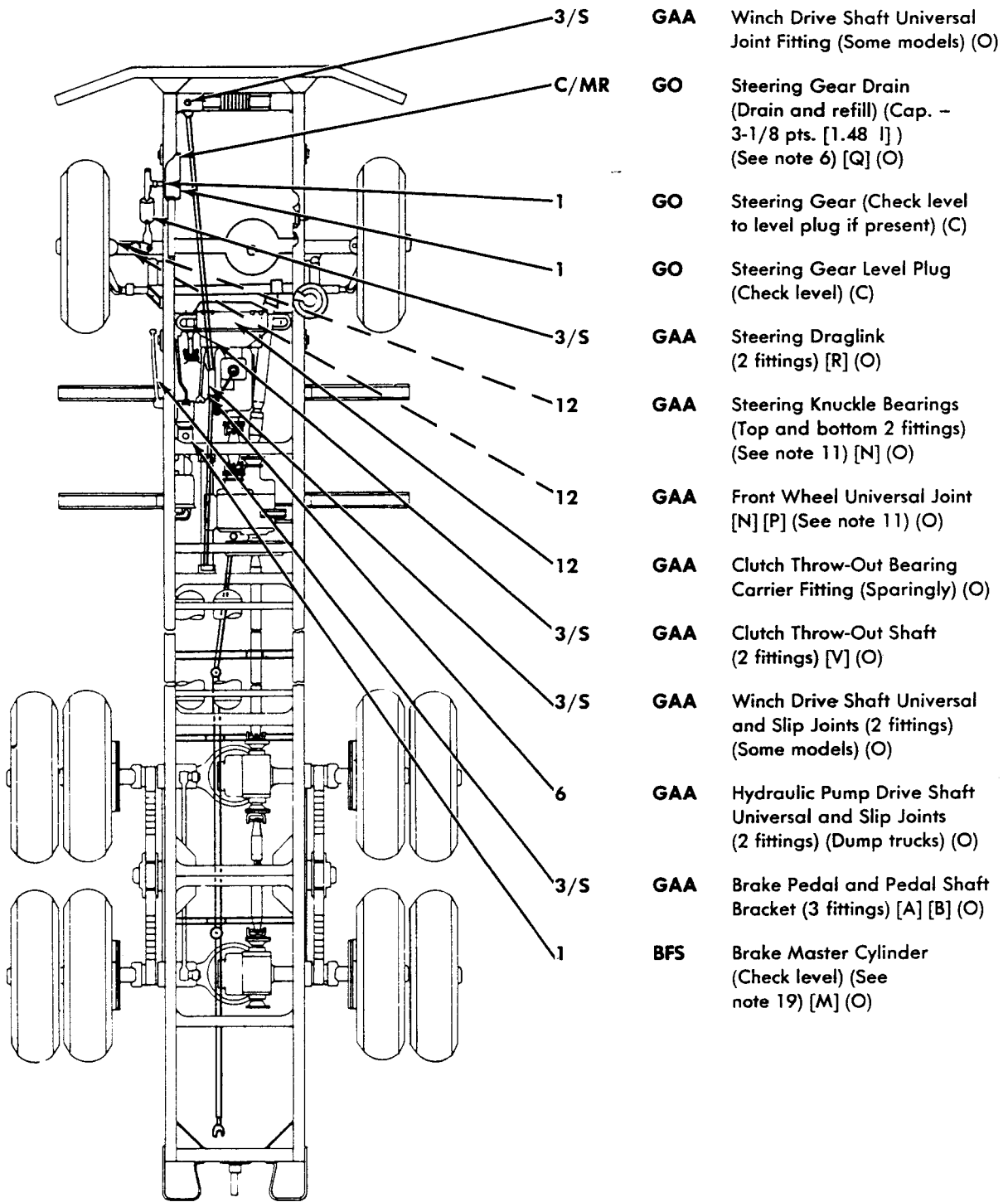

CHASSIS — M44A1, M44A2

NOTE

Letters in brackets after lubrication entries refer to localized views. See pages 21 through 29.

TA 252443

INTERVAL • LUBRICANT

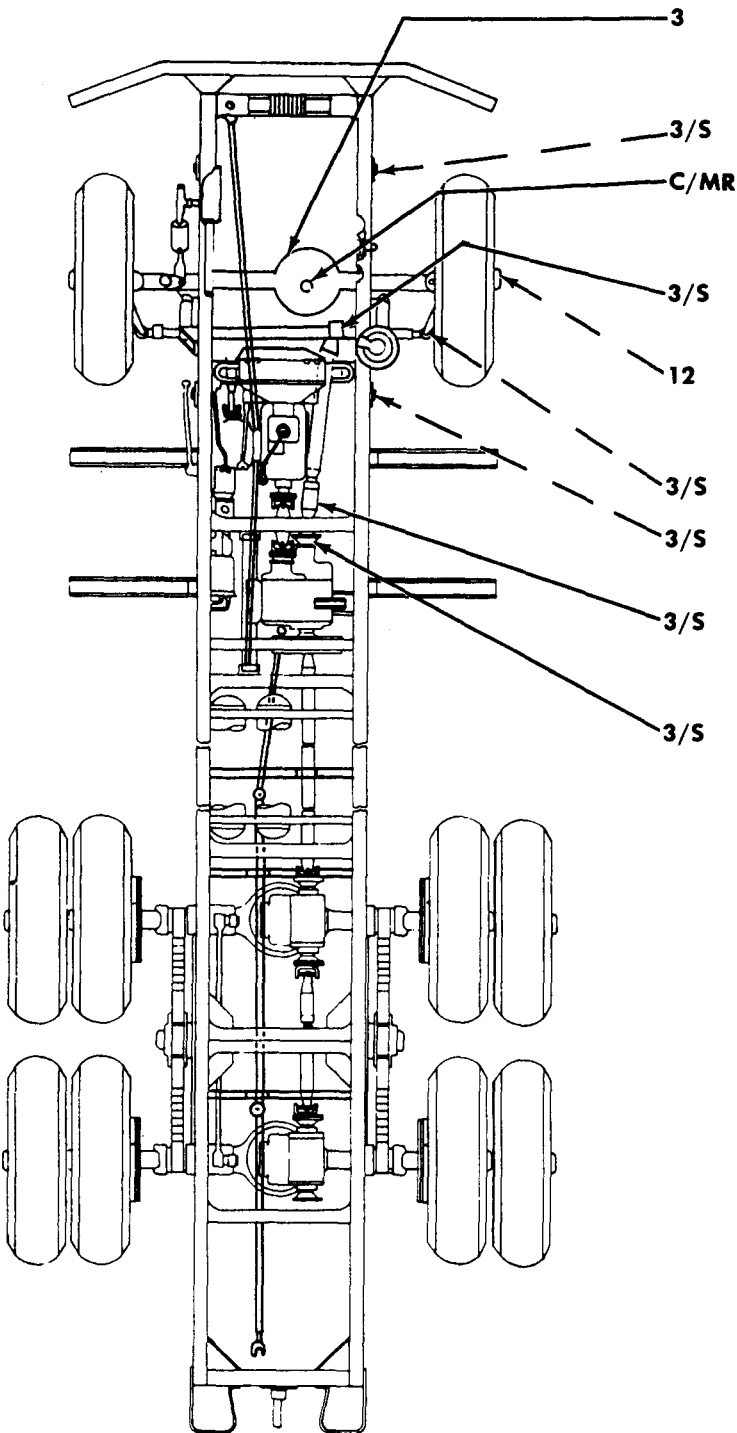

- GO** Front Axle Differential Fill and level (Check level) (See note 6) (O)
- GAA** Spring Bolt Fitting [S]
- C/MR** Front Axle Differential Drain (Drain and refill) (Cap. – 6 qts. [5.7 l]) (See note 6) (O)
- GAA** Front Axle Drive Shaft Universal Joint Fitting [U] (O)
- 12** **GAA** Front Wheel Bearings (Remove, clean, dry, and repack) (O)
- 3/S** **GAA** Tie Rod Fitting [T] (O)
- 3/S** **GAA** Spring Shackles (2 fittings) [S] (O)
- 3/S** **GAA** Front Axle Drive Shaft Universal and Slip Joints (2 fittings) [U] (O)
- 3/S** **GAA** Transmission to Transfer Case Drive Shaft Universal and Slip Joints (3 fittings) (O)

CHASSIS — M44A1, M44A2

NOTE

Letters in brackets after lubrication entries refer to localized views. See pages 21 through 29.

TA 252444

INTERVAL • LUBRICANT

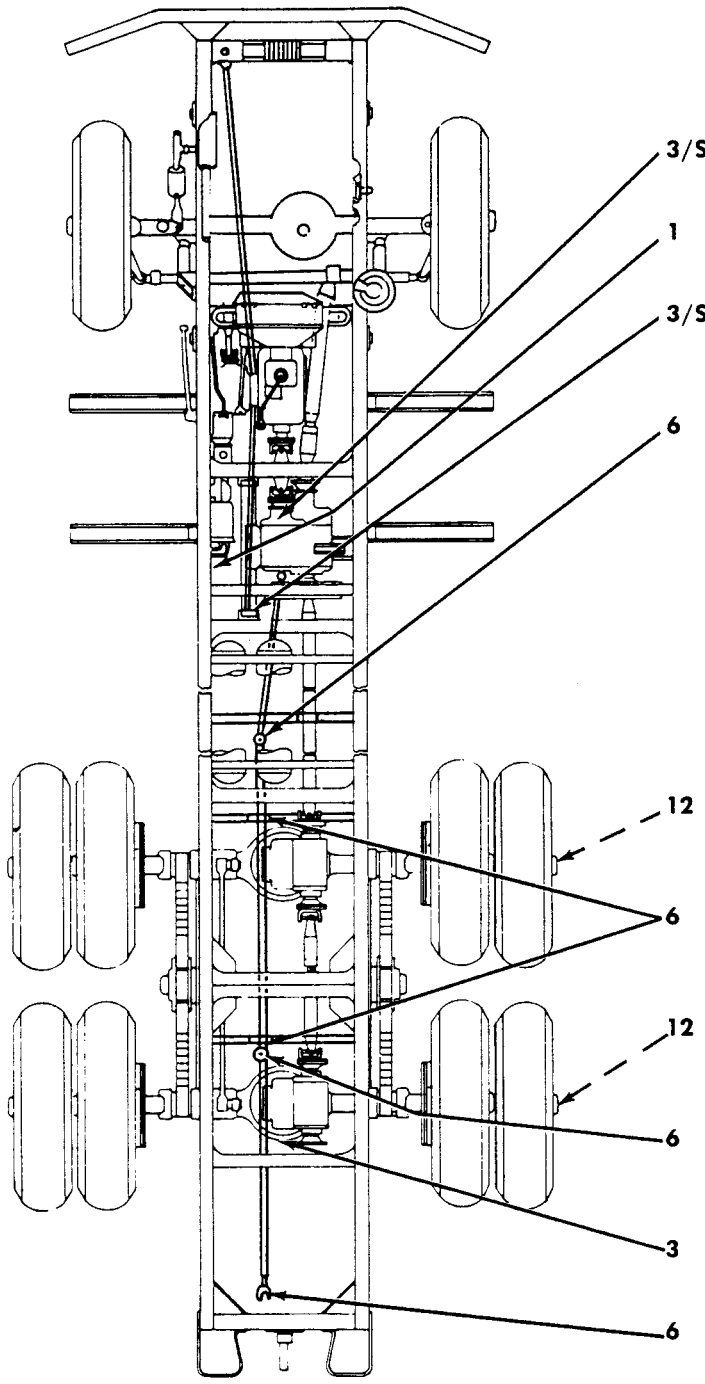

CHASSIS — M44A1, M44A2

- 3/S** **GAA** Speedometer Adapter Fitting [EE] (O)
- 1** **GAA** Handbrake Cable Fitting (Some models) [W] (O)
- 3/S** **GAA** Hydraulic Pump Drive Shaft Universal Joint Fitting (Dump trucks) [GG] (O)
- 6** **GAA** Pump Drive Shaft Universal and Slip Joints (2 fittings) (O)

- 12** **GAA** Rear Wheel Bearing (Remove, clean, dry, and repack)
- 6** **GAA** Drive Shaft Center Bearing Fitting (Fuel and water tankers) [HH] [LL] (O)
- 12** **GAA** Rear Wheel Bearing (Remove, clean, dry, and repack)
- 6** **GAA** Pump Drive Shaft Universal Joint Fitting (Fuel and water tankers) [JJ] (O)
- 3** **GO** Rear Axle Differential (Check level) (See note 6) (O)
- 6** **GAA** Pump Drive Shaft Universal and Slip Joint (2 fittings) (Fuel and water tankers) [JJ] [KK] [XX] (O)

NOTE

Letters in brackets after lubrication entries refer to localized views. See pages 21 through 29.

TA 252445

INTERVAL • LUBRICANT

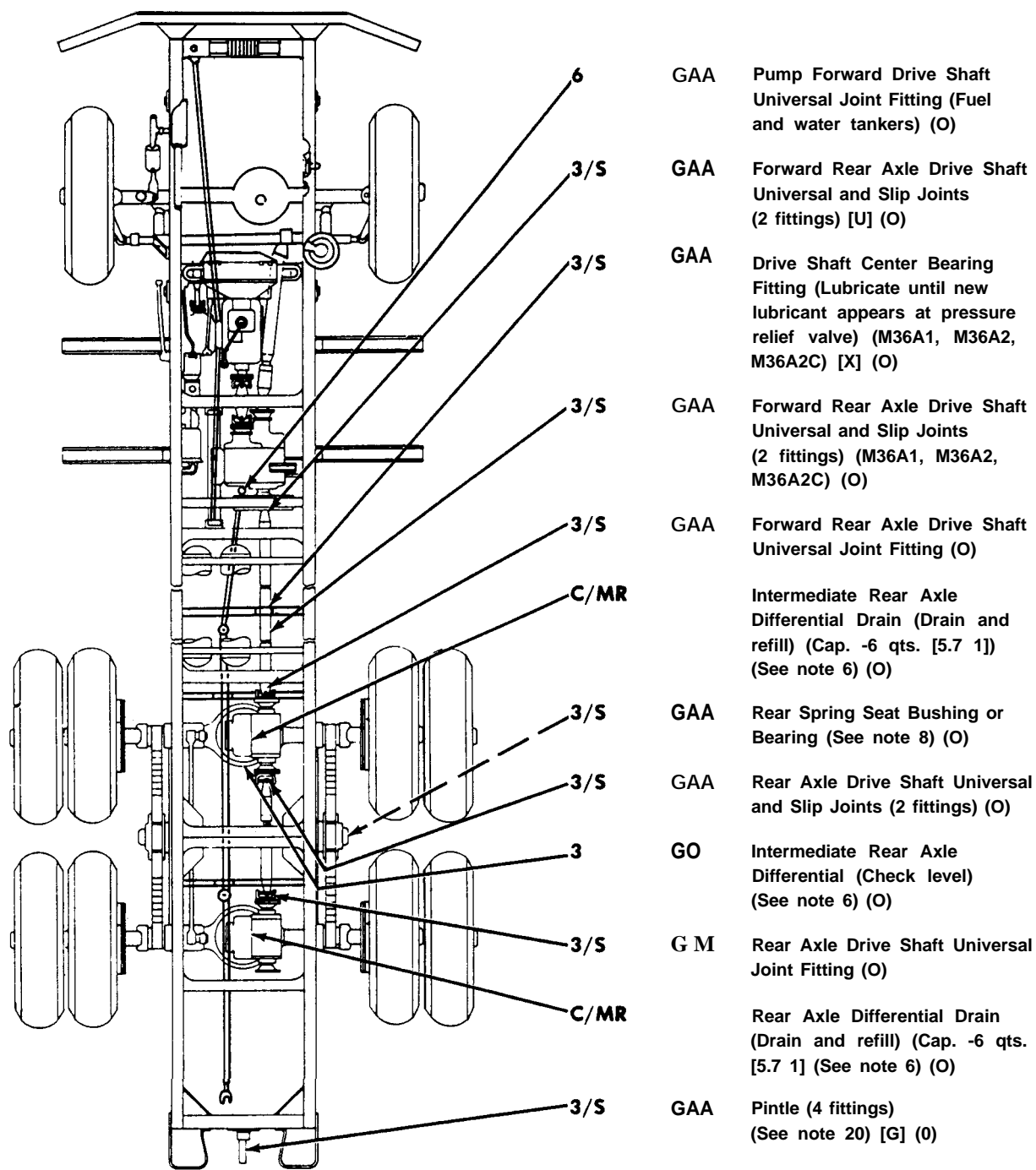

CHASSIS — M44A1, M44A2

NOTE

Letters in brackets after lubrication entries refer to localized views. See pages 21 through 29.

TA 252446

NOTE

Hours in the interval column refer to hours of operation. When two intervals are shown, lubricate at the interval which occurs first.

INTERVAL • LUBRICANT

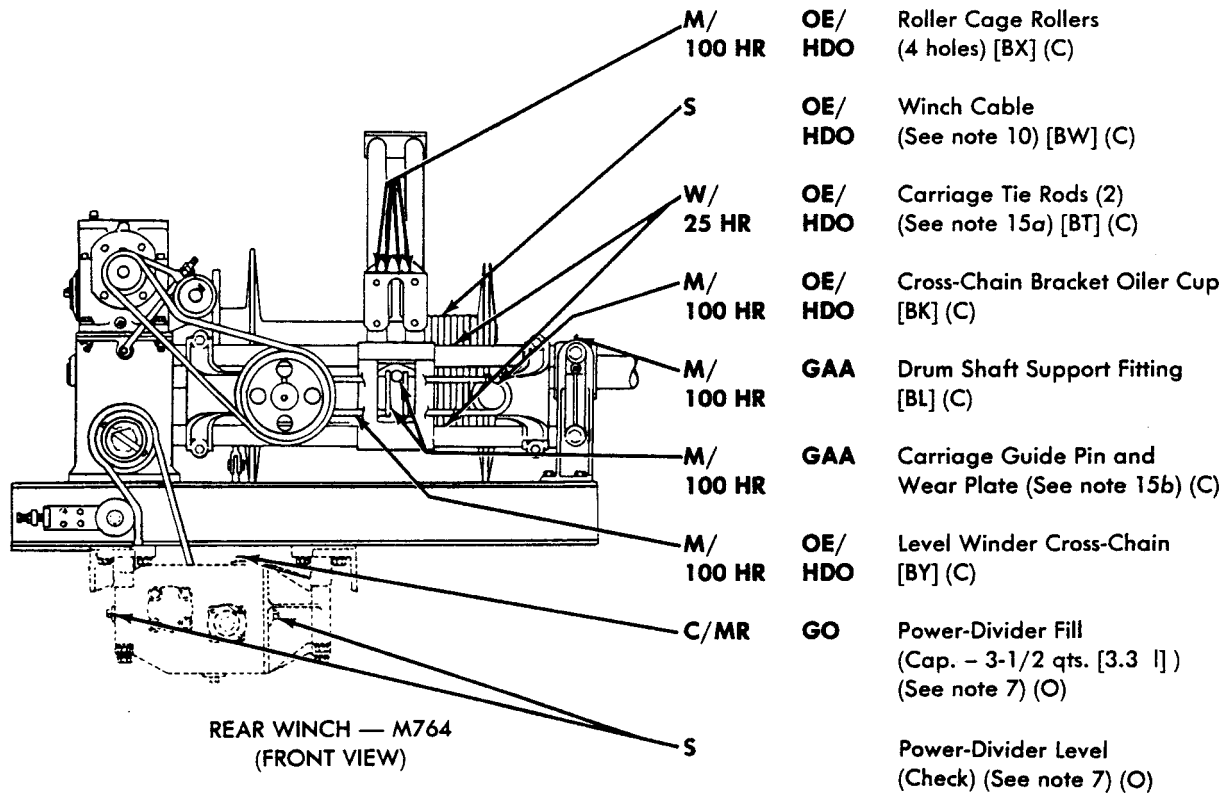

NOTE

Letters in brackets after lubrication entries refer to localized views. See pages 21 through 29.

TA 252447

NOTE

Hours in the interval column refer to hours of operation. When two intervals are shown, lubricate at the interval which occurs first.

INTERVAL • LUBRICANT

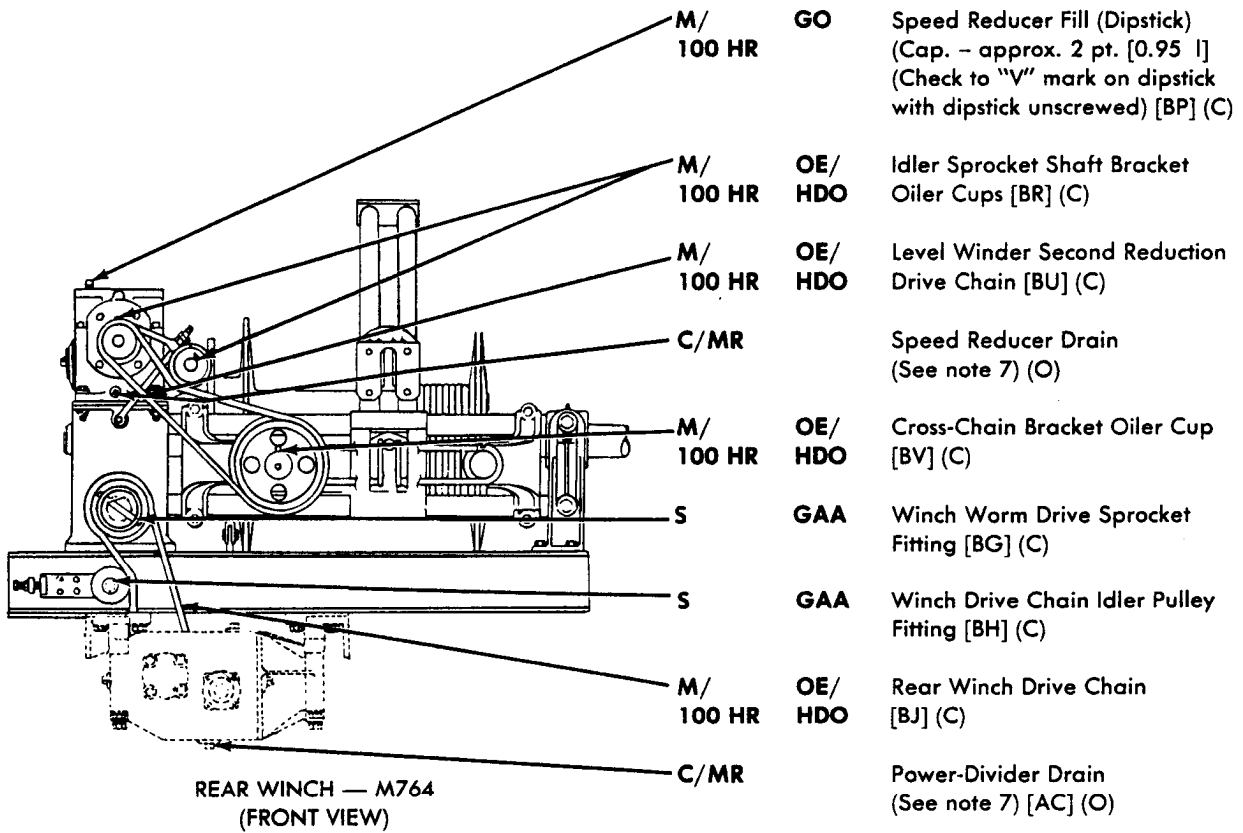

NOTE

Letters in brackets after lubrication entries refer to localized views. See pages 21 through 29.

TA 252448

NOTE

Hours in the interval column refer to hours of operation. When two intervals are shown, lubricate at the interval which occurs first.

INTERVAL • LUBRICANT

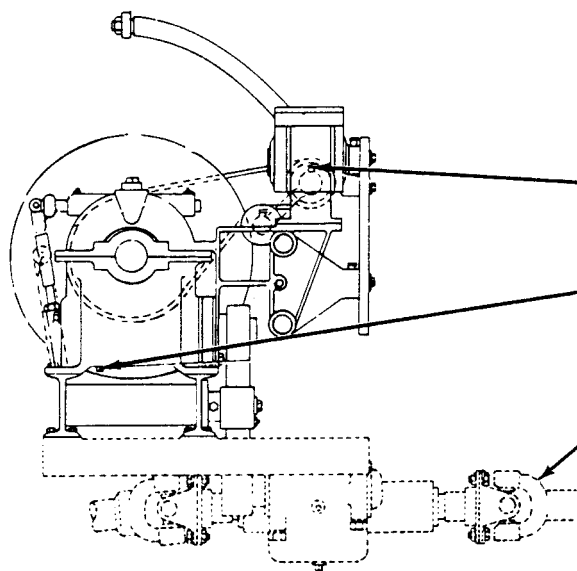

M/ 100 HR	OE/ HDO	Idler Sprocket Shaft Bracket Oiler Cups (2) [BQ] (C)
C/MR		Worm Gear Housing Drain Plug (See note 7) (O)
S	GAA	Earth Boring Machine CB, Propeller Shaft (3 fittings) [AD] (C)

REAR WINCH — M764
(SIDE VIEW)

LUBRICANT • INTERVAL

Level Winder First Reduction Drive Chain [BS] (C)	OE/ HDO	M/ 100 HR
Worm Gear Housing Filler Plug (Cap. — 7 pts. [3.3 l]) (See note 7) [BM] (O)	GO	C/MR
Clutch Fork Shaft (2 fittings) [BN] (C)	GAA	M
Cable Tension Roller (Both ends) (C)	OE/ HDO	M/ 100 HR
Worm Gear Housing Level Plug (2) (Check level) (O)		S
Power-Divider Propeller Shaft (3 fittings) [AB] (C)	GAA	S

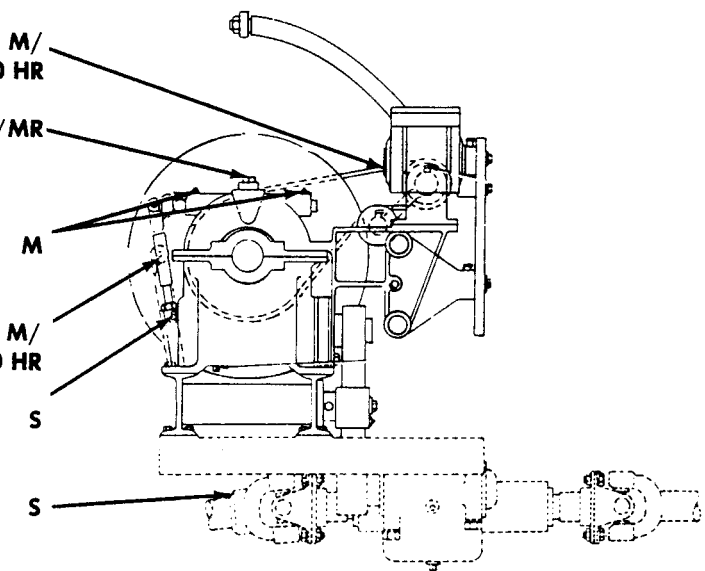

REAR WINCH — M764
(SIDE VIEW)

NOTE

Letters in brackets after lubrication entries refer to localized views. See pages 21 through 29.

TA 252449

NOTE

Hours in the interval column refer to hours of operation. When two intervals are shown, lubricate at the interval which occurs first.

INTERVAL • LUBRICANT

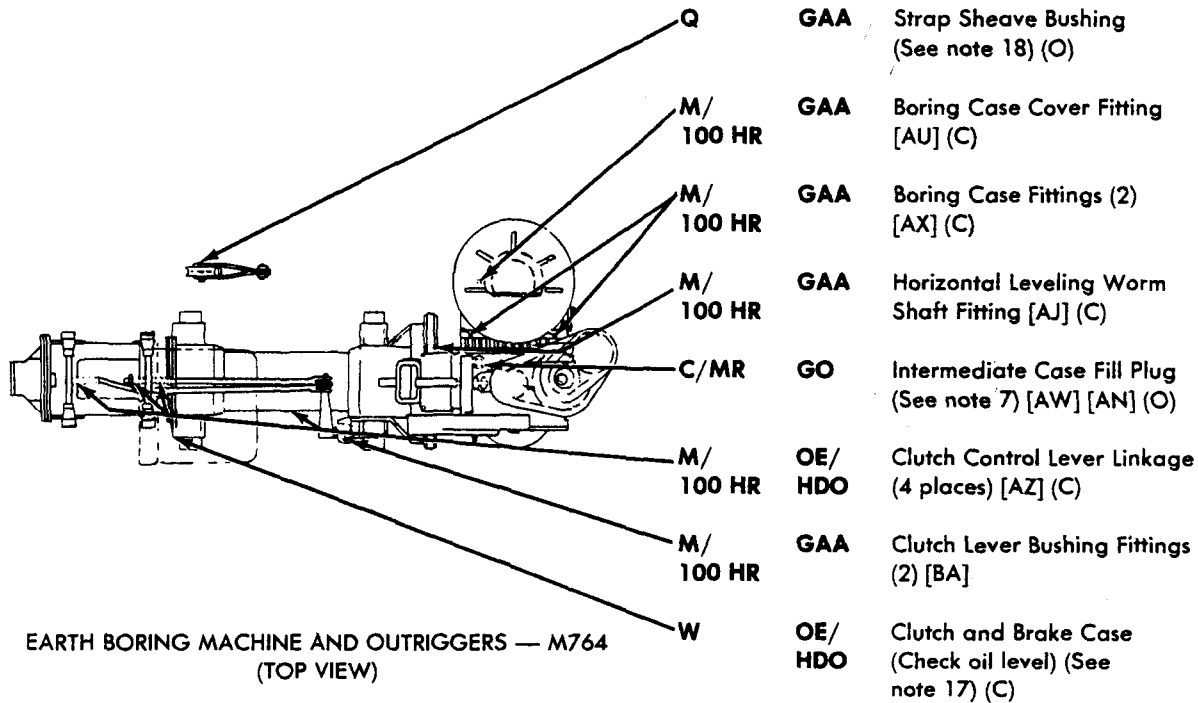

EARTH BORING MACHINE AND OUTRIGGERS — M764
(TOP VIEW)

NOTE

Letters in brackets after lubrication entries refer to localized views. See pages 21 through 29.

TA 252450

NOTE

Hours in the interval column refer to hours of operation. When two intervals are shown, lubricate at the interval which occurs first.

INTERVAL • LUBRICANT

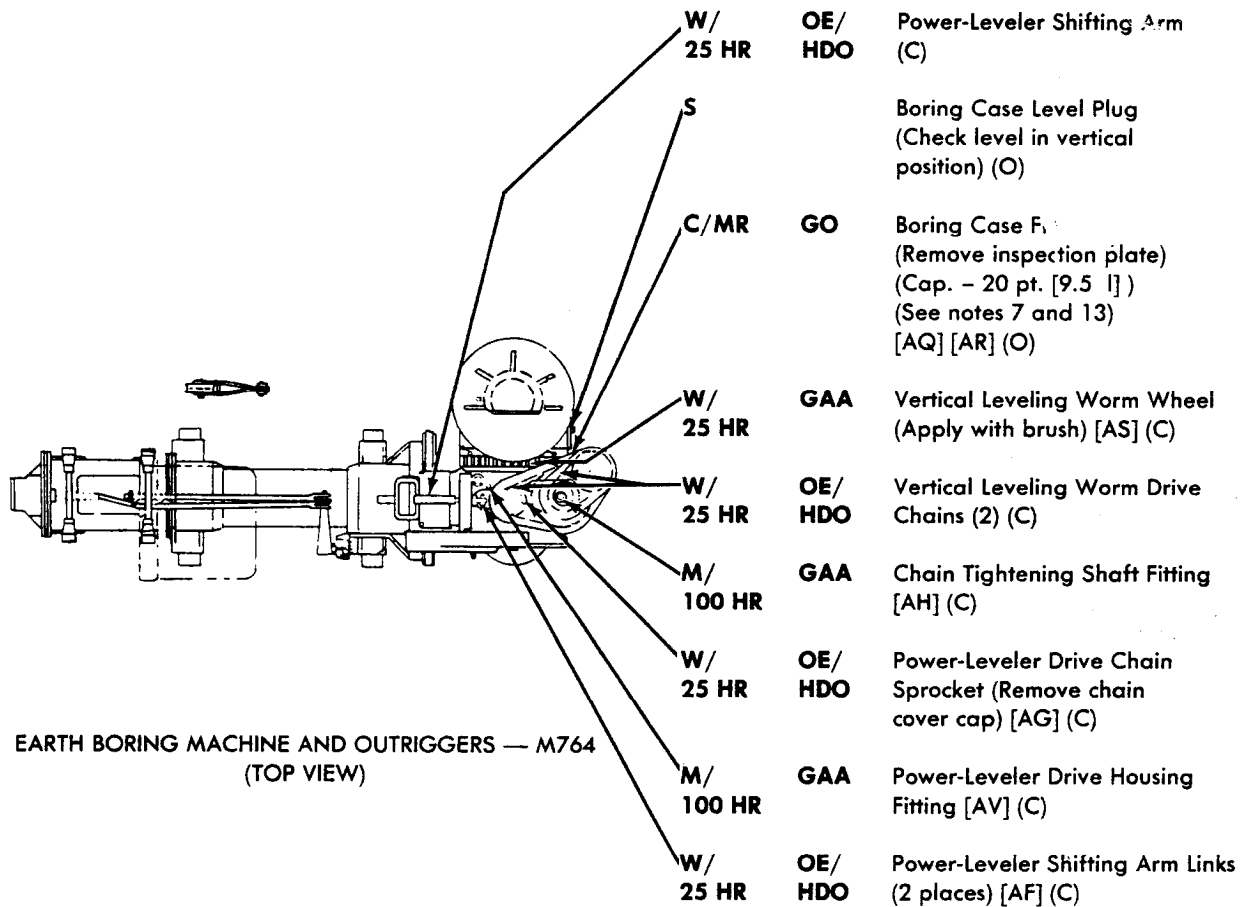

NOTE

Letters in brackets after lubrication entries refer to localized views. See pages 21 through 29.

TA 252451

NOTE

Hours in the interval column refer to hours of operation. When two intervals are shown, lubricate at the interval which occurs first.

INTERVAL ● LUBRICANT

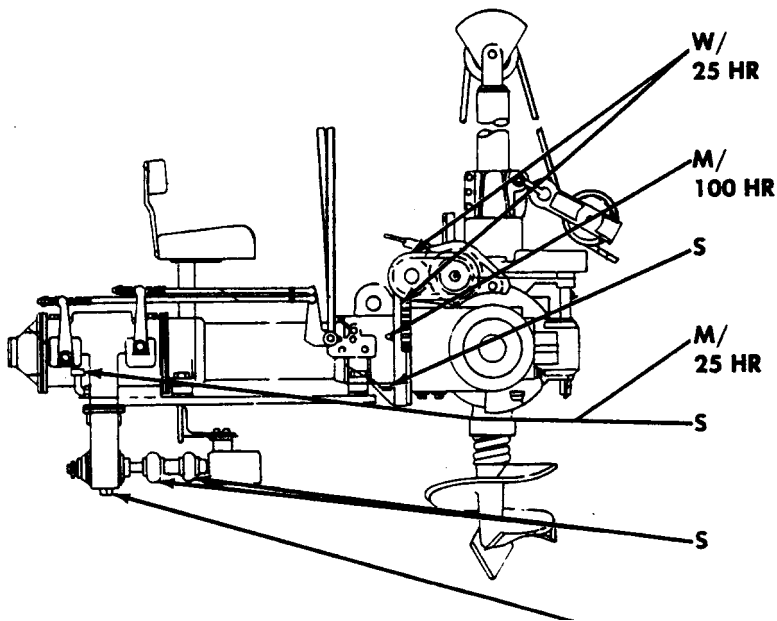

GAA Horizontal Leveling Worm Wheel and Worm (Apply with brush) [AK] (C)

GAA Supporting Tube Fitting [AL] (C)

S Supporting Tube Drain Plug (o)

M/ 25 HR Main Drive Idler Gear Housing Dipstick (Check level) [AY] (C)

OE/ HDO Main Drive Idler, Gear Housing Fill and Level Dipstick (Cap. -5 qt. [4.7 l]) (C)

GAA Outrigger Hydraulic Pump Drive Shaft Universal Joints (See note 16b) [BD] (o)

Main Drive idler Gear Housing Drain Plug [BC] (o)

EARTH BORING MACHINE AND OUTRIGGERS — M764
(SIDE VIEW)

NOTE

Letters in brackets after lubrication entries refer to localized views. See pages 21 through 29.

TA 252452

NOTE

Hours in the interval column refer to hours of operation. When two intervals are shown, lubricate at the interval which occurs first.

INTERVAL • LUBRICANT

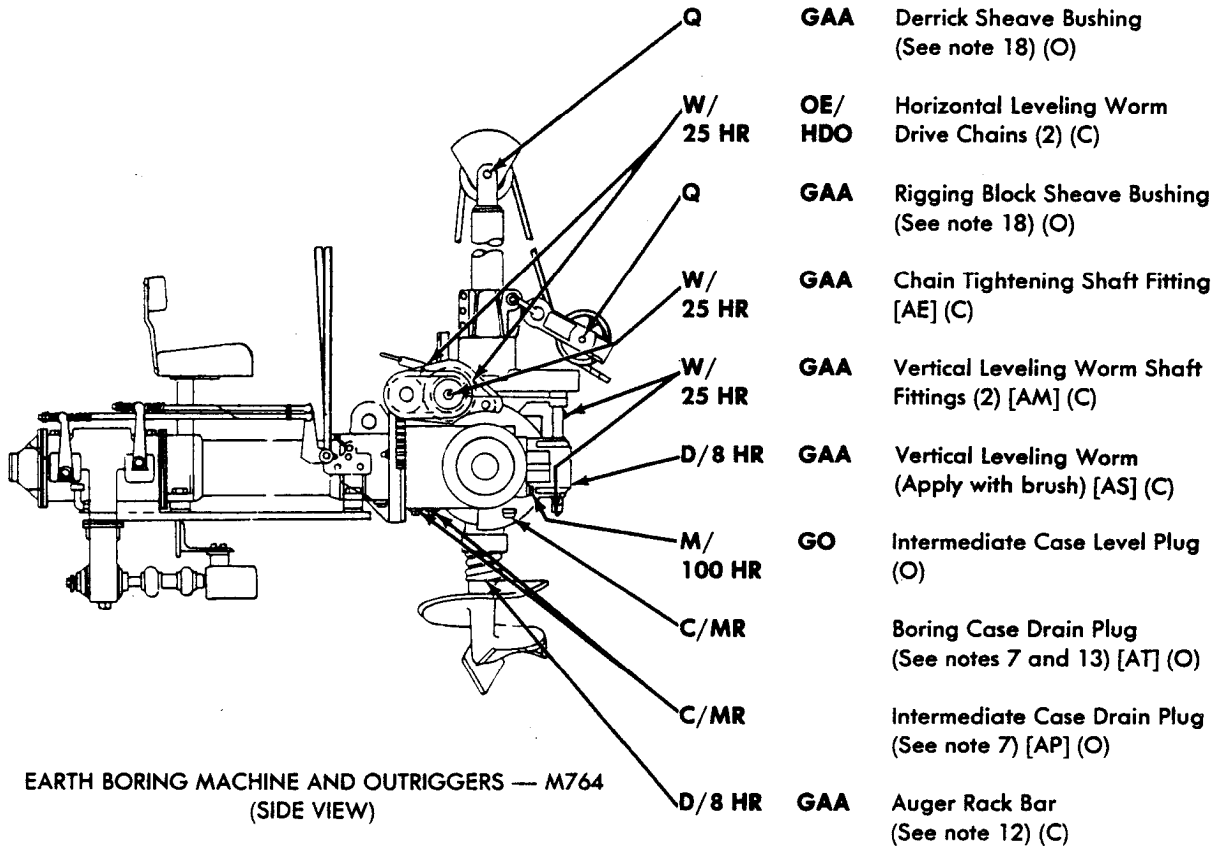

**EARTH BORING MACHINE AND OUTRIGGERS — M764
(SIDE VIEW)**

NOTE

Letters in brackets after lubrication entries refer to localized views. See pages 21 through 29.

TA 252453

NOTE

Hours in the interval column refer to hours of operation. When two intervals are shown, lubricate at the interval which occurs first.

INTERVAL • LUBRICANT

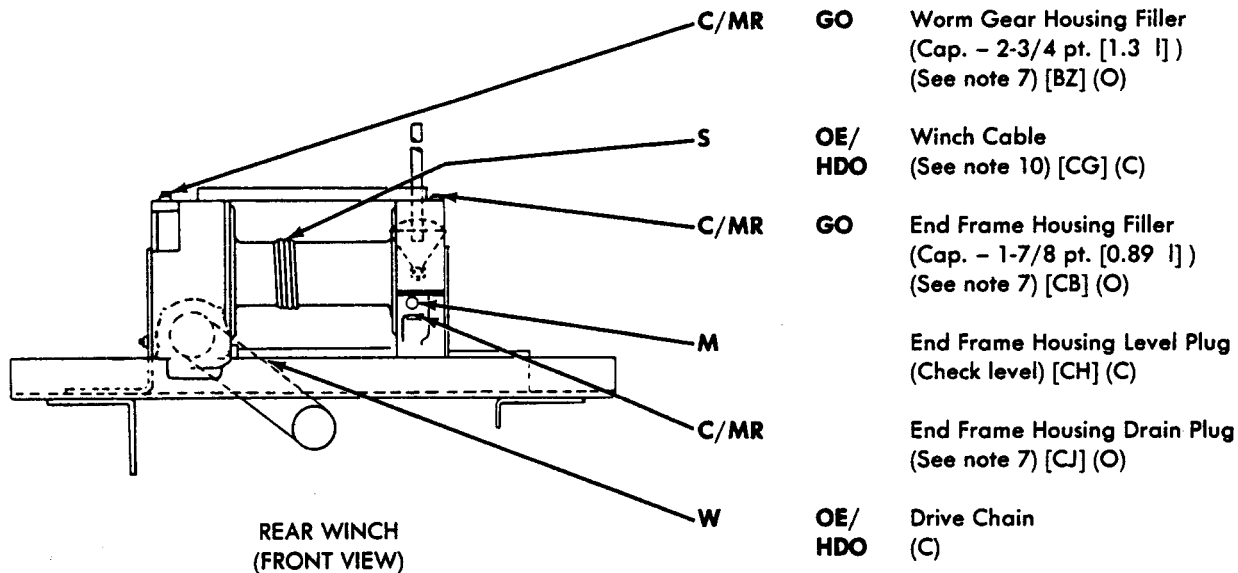

INTERVAL • LUBRICANT

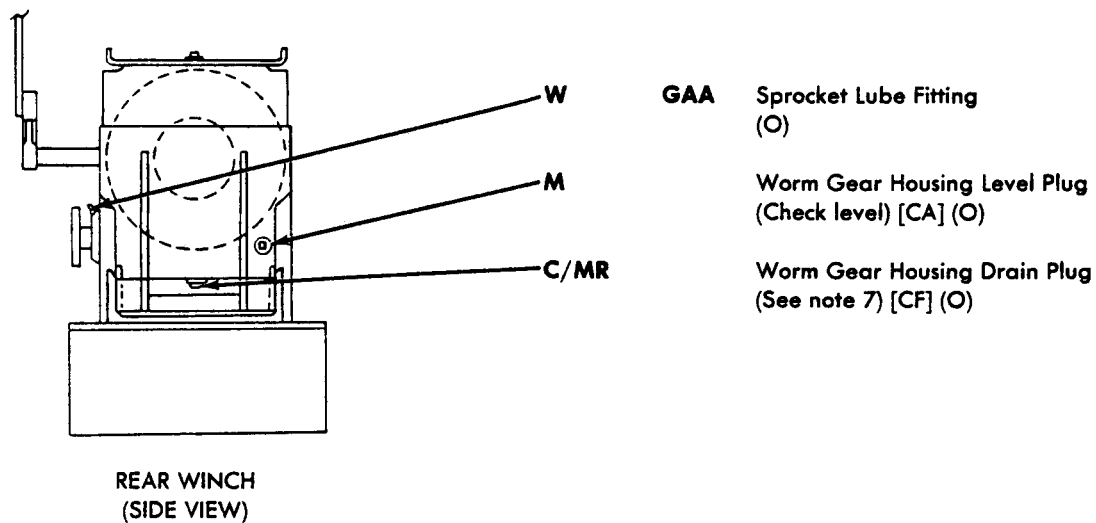

NOTE

Letters in brackets after lubrication entries refer to localized views. See pages 21 through 29.

TA 252454

NOTE

Hours in the interval column refer to hours of operation. When two intervals are shown, lubricate at the interval which occurs first.

INTERVAL • LUBRICANT

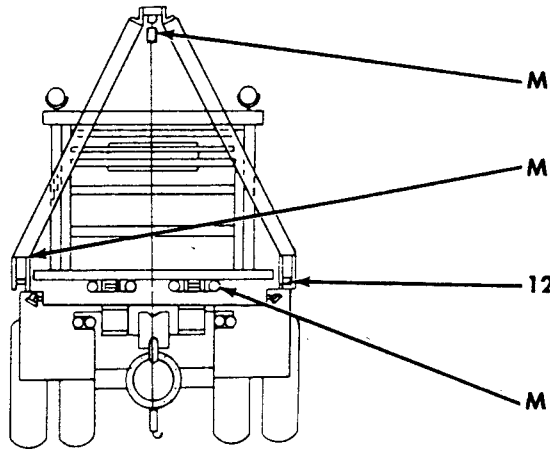

- GAA** Sheave Assembly
(3 places) (C)
- GAA** Gin Pole Link and Pin
(Tailboard Bracket) (Each side)
[CD] (C)
- GAA** Pack Roller Bearings
(At assembly) (Each end)
[CE] (O)
- GAA** Auxiliary Roller Bracket
(4 places) [CK] (C)

WINCH, PIPELINE CONSTRUCTION — M756A2
(REAR VIEW)

INTERVAL • LUBRICANT

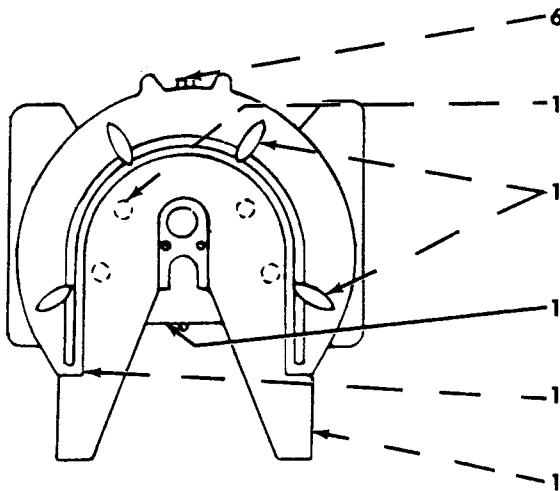

- OE/
HDO** Lock Plunger Shaft and Latch
(2 fittings) [NN] (O)
- GAA** Coupler Jaw Pin
[QQ] (C)
- GAA** Base Wheel
(Clean and coat)
[PP] [VV] [TT] (C)
- GAA** Lateral Shaft
(Both ends) [SS] or [WW] (C)
- GAA** Support Bracket
[RR] (C)
- GAA** Base Ramp
(Clean and coat) (2 fittings)
[UU] (O)

FIFTH WHEEL — M275A1, M275A2

NOTE

Letters in brackets after lubrication entries refer to localized views. See pages 21 through 29.

TA 252455

NOTE

Hours in the interval column refer to hours of operation. When two intervals are shown, lubricate at the interval which occurs first.

INTERVAL • LUBRICANT

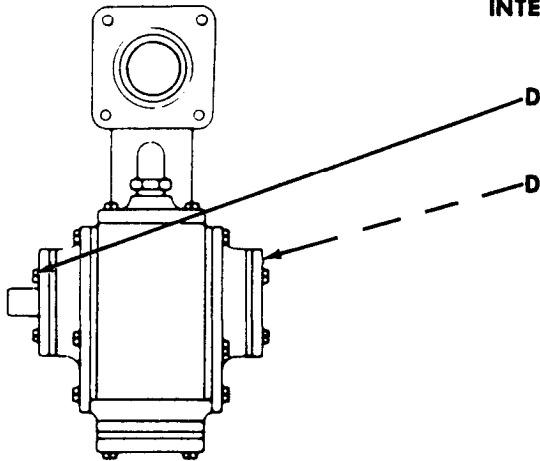

- GAA** Pump Drive
(When in use) (C)
- GAA** Pump Bearing
(Lubricate until lubricant appears at relief valve when in use) [YY] (C)

PUMP, GASOLINE SERVICE — M49A1C, M49A2C
PUMP, WATER SERVICE — M50A1, M50A2, M50A3

LUBRICANT • INTERVAL

- Hoist Cylinder Base Shaft
(1 fitting) [Y] (O)
- Hydraulic Reservoir
(Check level) (See note 9) (C)
- Control Lever Shaft
(2 fittings) [ZZ] or [FF] (O)
- Hydraulic Pump Control Box
(1 fitting) [MM] (O)

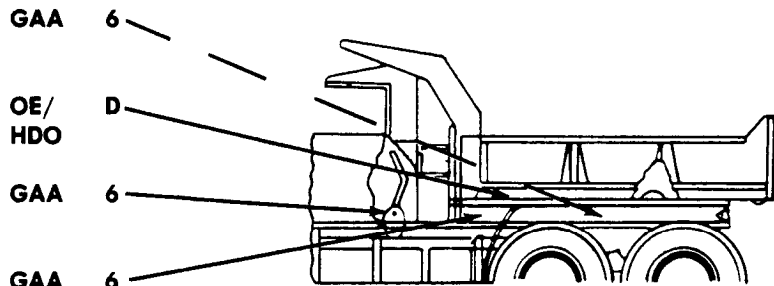

DUMP BODY — M342A2
(SIDE VIEW)

INTERVAL • LUBRICANT

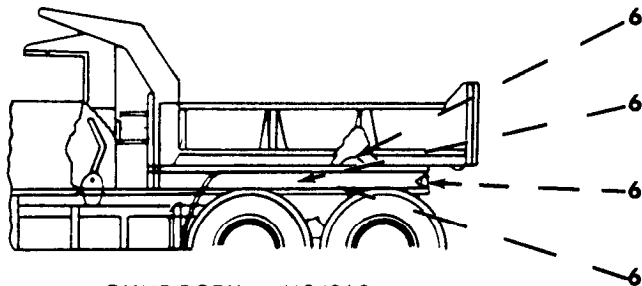

DUMP BODY — M342A2
(SIDE VIEW)

- GAA** Hoist Lift Pin
(1 fitting) [AA] (O)
- GAA** Roller Arm Pin
(1 fitting) [Z] (O)
- GAA** Body Hinge Pin
(1 fitting) [CC] (O)
- GAA** Hoist Cylinder Cross Head
(1 fitting) [BB] (O)

NOTE

Letters in brackets after lubrication entries refer to localized views. See pages 21 through 29.

TA 252456

LOCALIZED LUBRICATION POINTS (A THROUGH L)

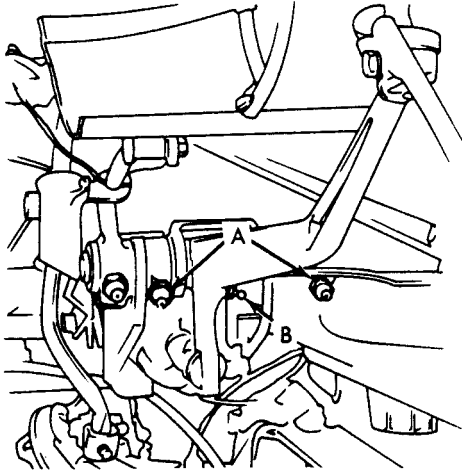

BRAKE PEDAL AND
PEDAL SHAFT BRACKET

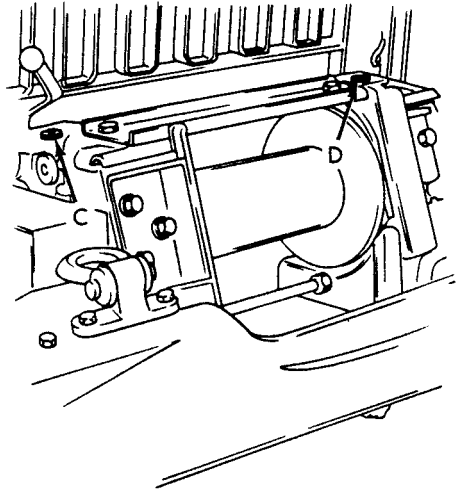

FRONT WINCH

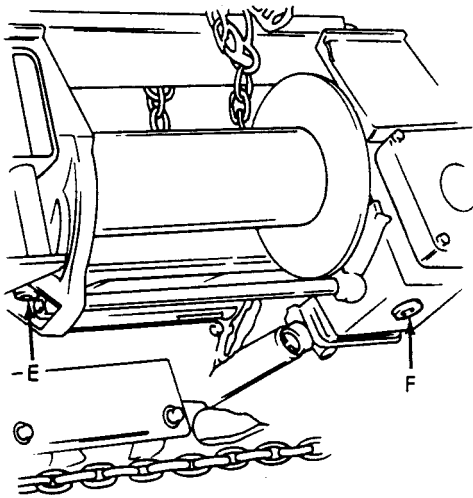

FRONT WINCH

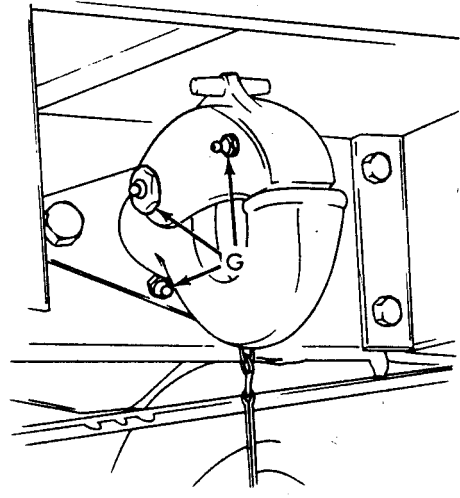

PINTLE

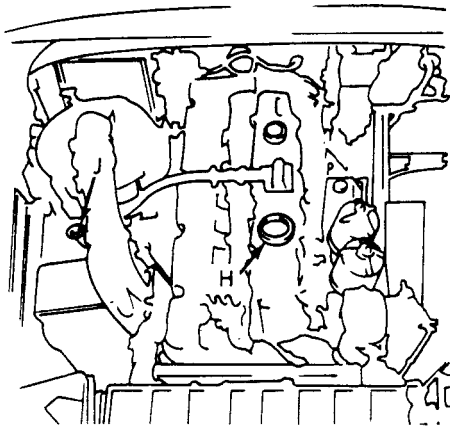

ENGINE CRANKCASE

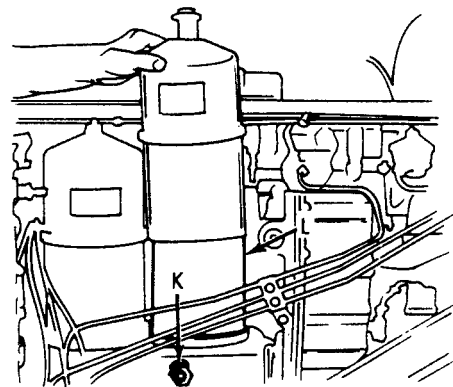

OIL FILTERS AND DRAIN PLUG TA 252457

LOCALIZED LUBRICATION POINTS (M THROUGH S)

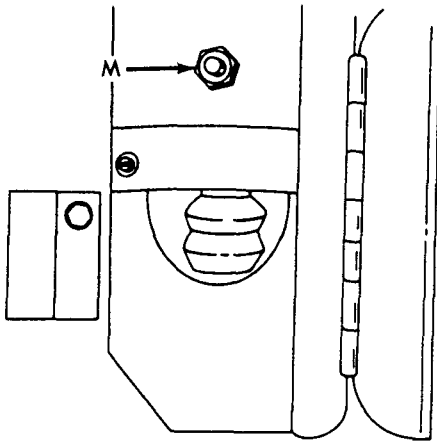

BRAKE MASTER CYLINDER

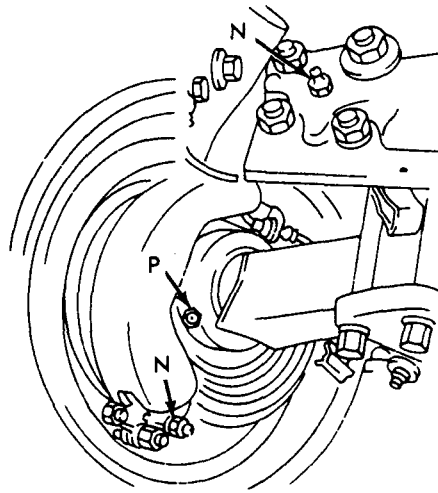

FRONT WHEEL

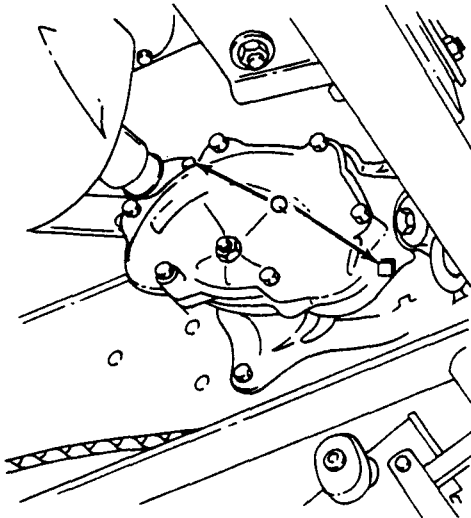

STEERING GEAR

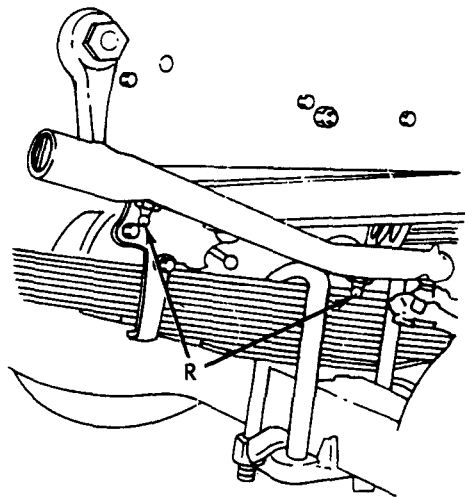

STEERING DRAG LINK

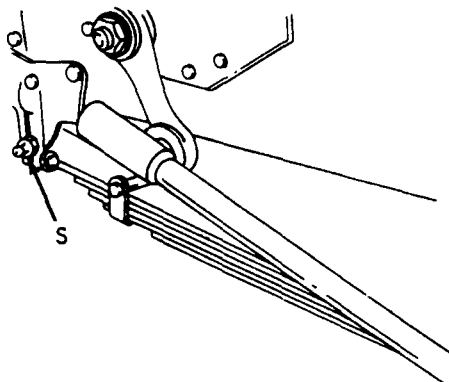

SPRING BOLT FITTINGS

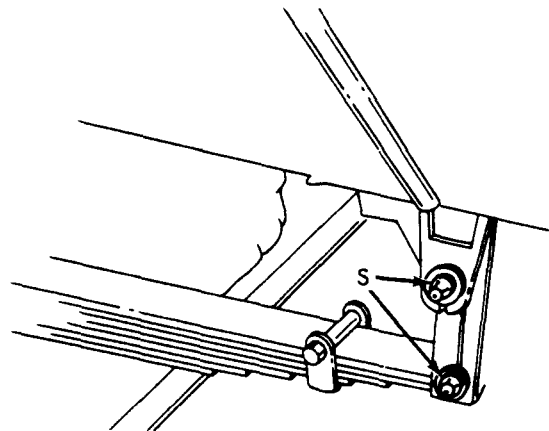

TA 252458

LOCALIZED LUBRICATION POINTS (T THROUGH Y)

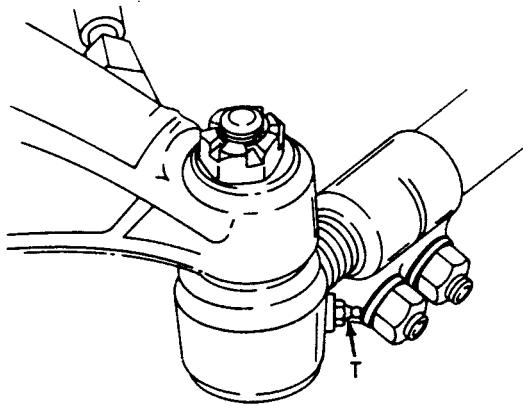

TIE ROD

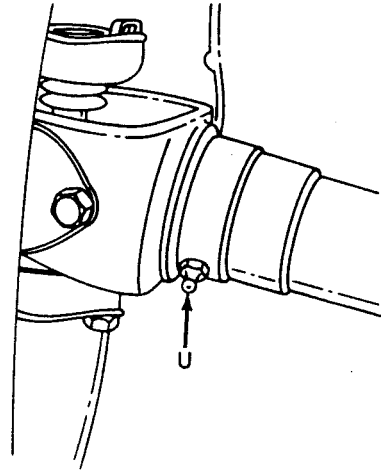

FRONT AXLE
DRIVE SHAFT

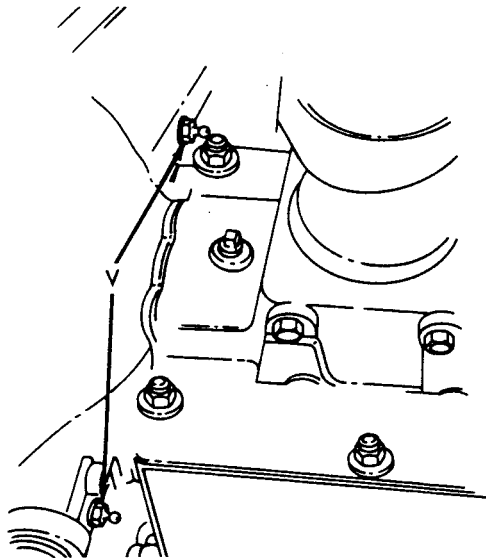

CLUTCH THROW-OUT SHAFT

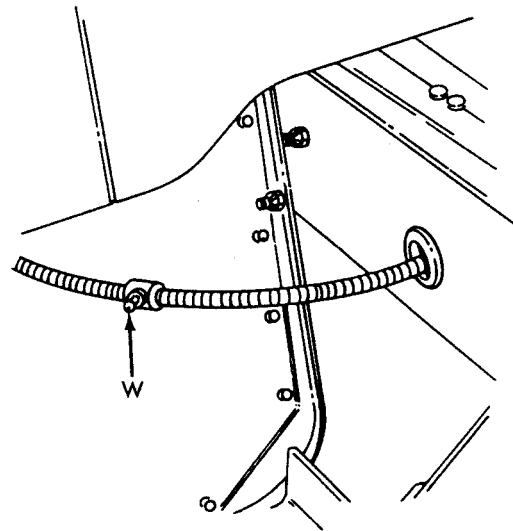

HANDBRAKE CABLE

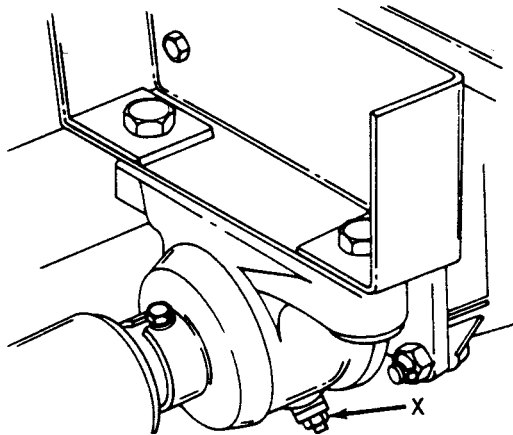

DRIVE SHAFT CENTER BEARING

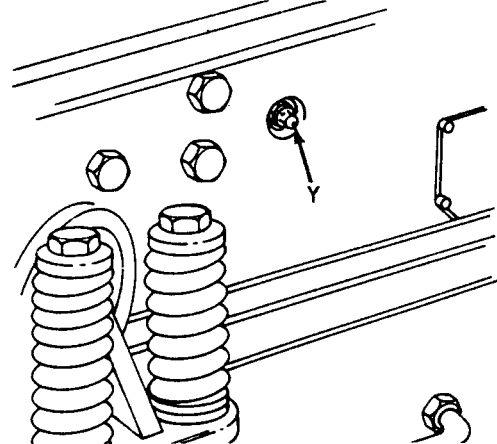

HOIST CYLINDER BASE SHAFT

TA 252459

LOCALIZED LUBRICATION POINTS (Z THROUGH FF)

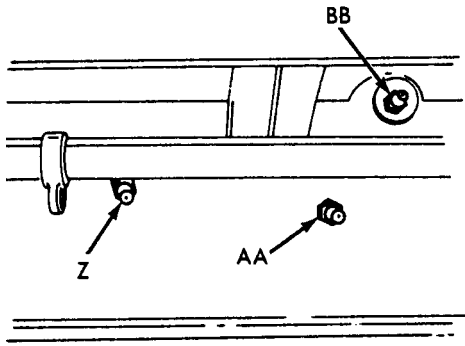

HOIST

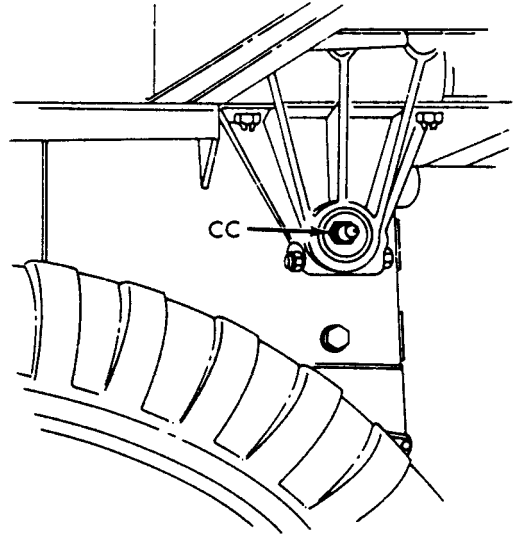

BODY KING PIN

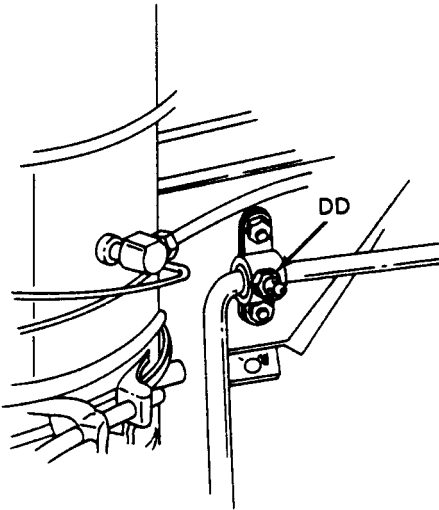

STARTER CROSS SHAFT

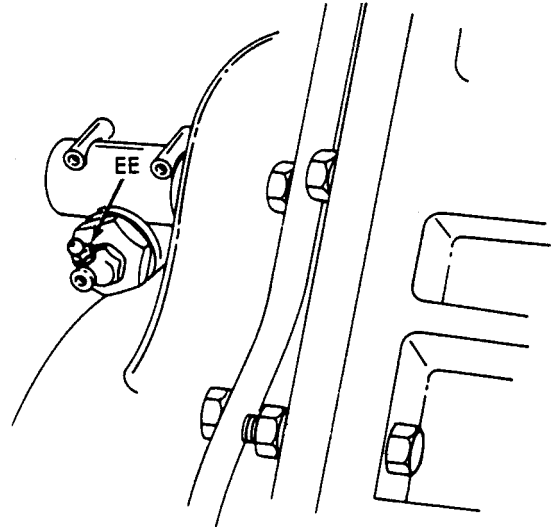

SPEEDOMETER ADAPTER

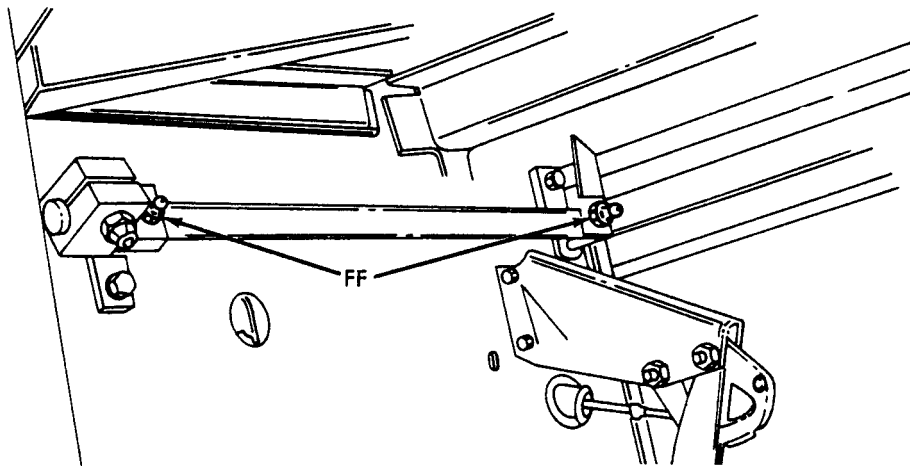

CONTROL LEVER SHAFT

TA 252460

LOCALIZED LUBRICATION POINTS (GG THROUGH SS)

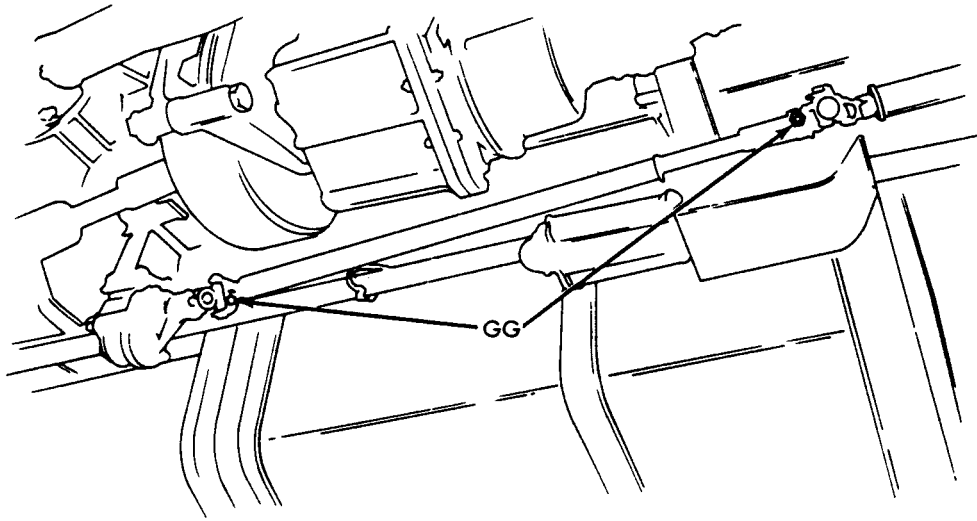

HYDRAULIC PUMP DRIVE SHAFT

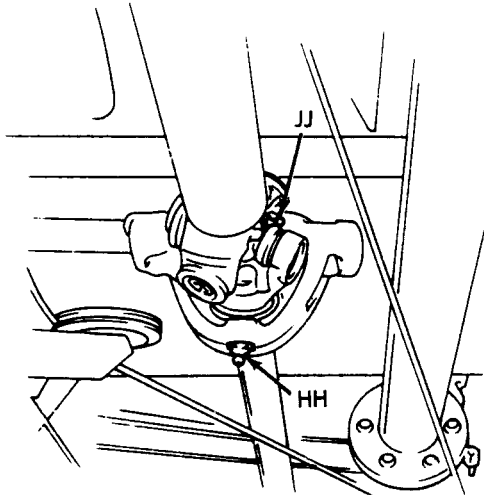

PUMP DRIVE SHAFT
UNIVERSAL JOINT

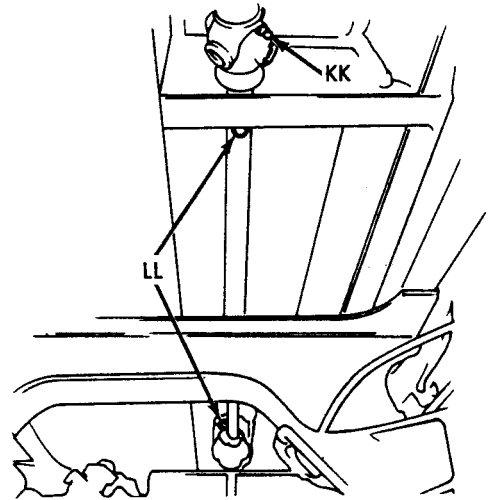

HYDRAULIC PUMP
DRIVE SHAFT

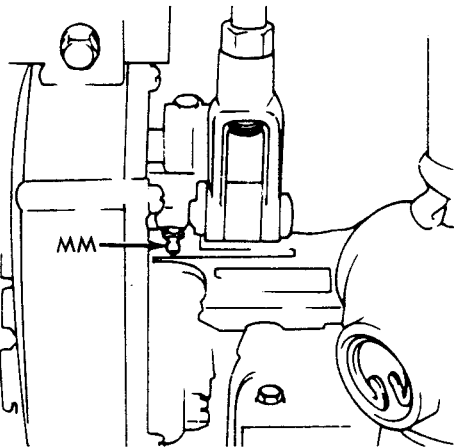

HYDRAULIC PUMP CONTROL BOX

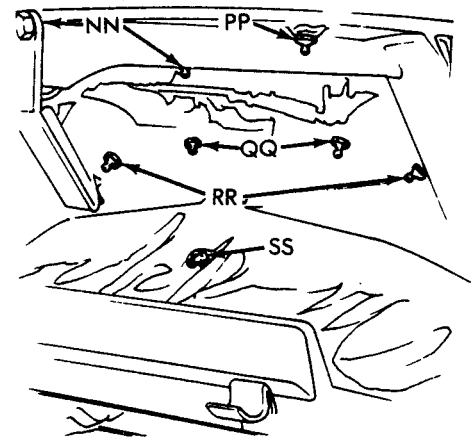

FIFTH WHEEL

TA 252461

LOCALIZED LUBRICATION POINTS (TT THROUGH AD)

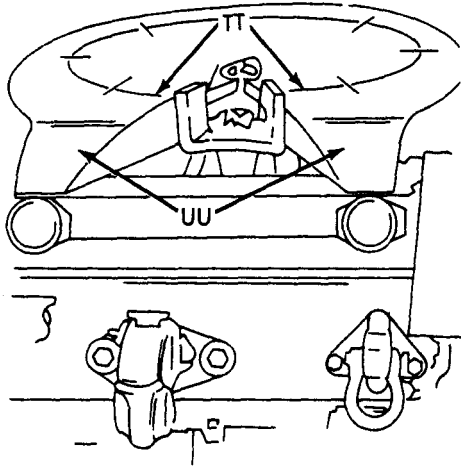

FIFTH WHEEL BASE RAMP



FIFTH WHEEL LATERAL SHAFT

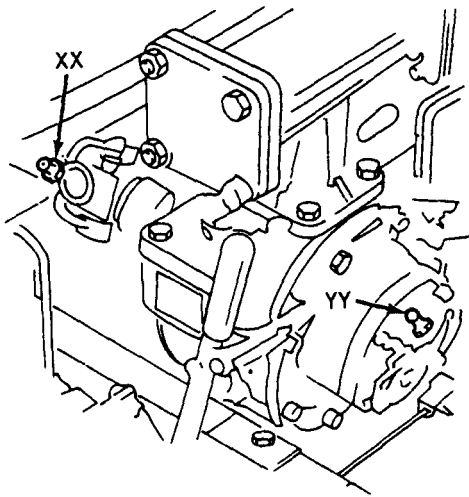

SERVICE PUMP

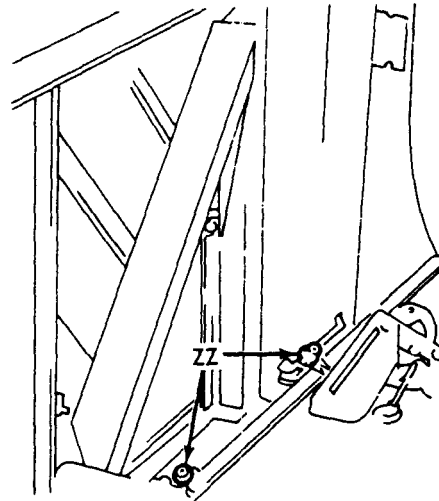

CONTROL LEVER

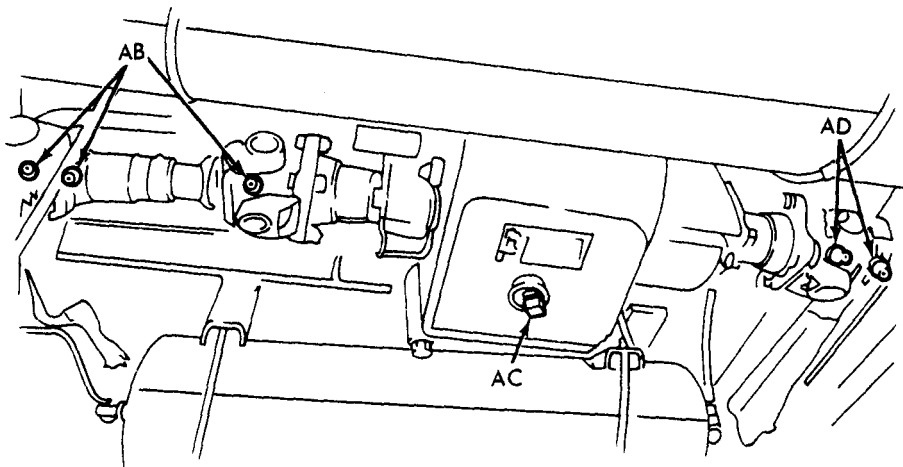

POWER-DIVIDER

TA 252467

LOCALIZED LUBRICATION POINTS (AE THROUGH BA)

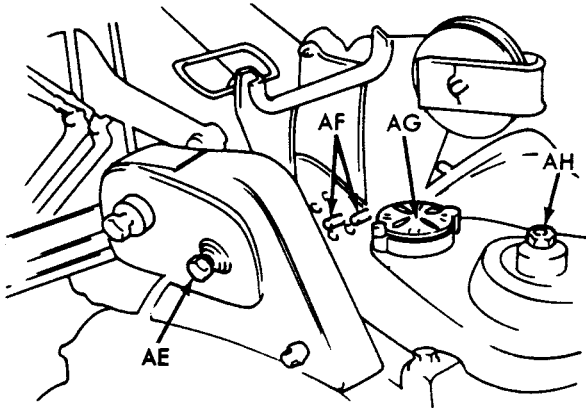

POWER-LEVELER

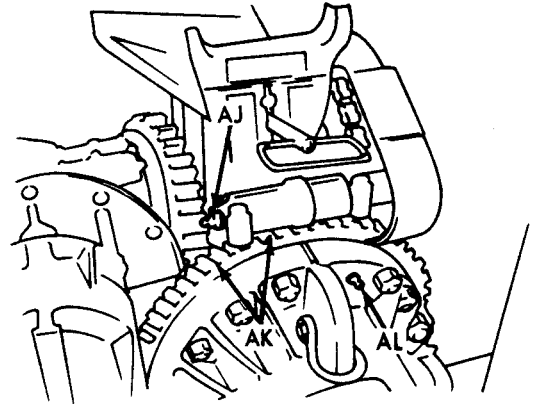

HORIZONTAL LEVER

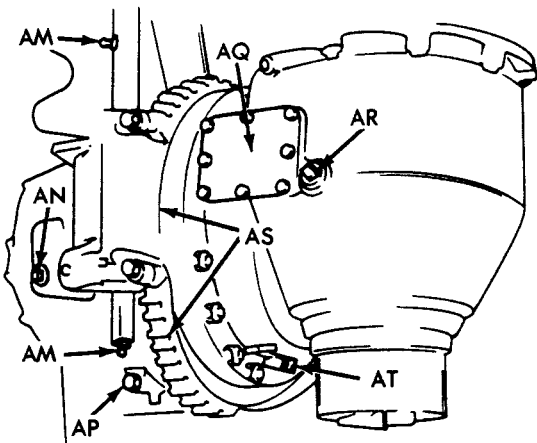

BORING CASE

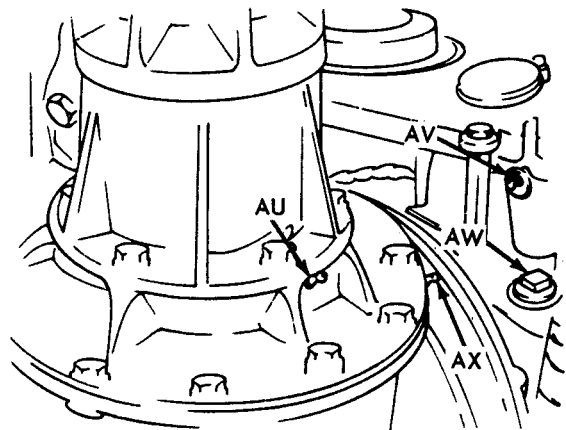

BORING CASE COVER

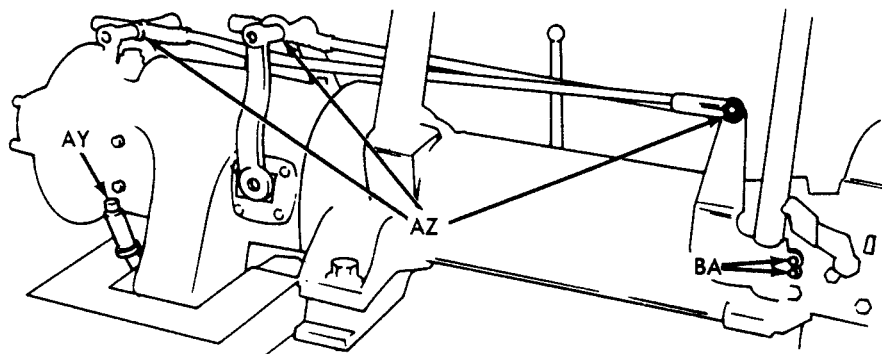

CLUTCH CONTROL LEVER

TA 252463

LOCALIZED LUBRICATION POINTS (BC THROUGH BY)

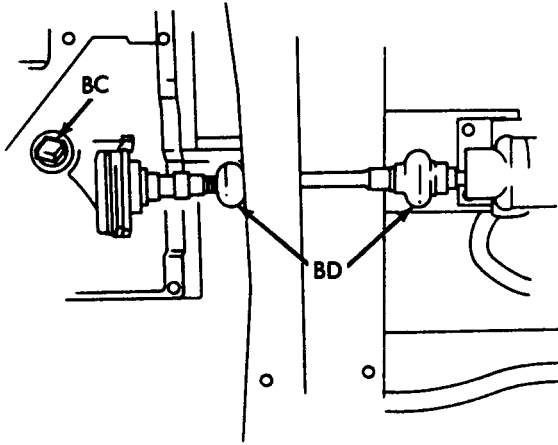

HYDRAULIC PUMP

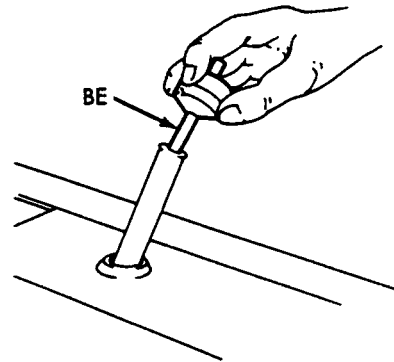

OUTRIGGER OIL RESERVOIR

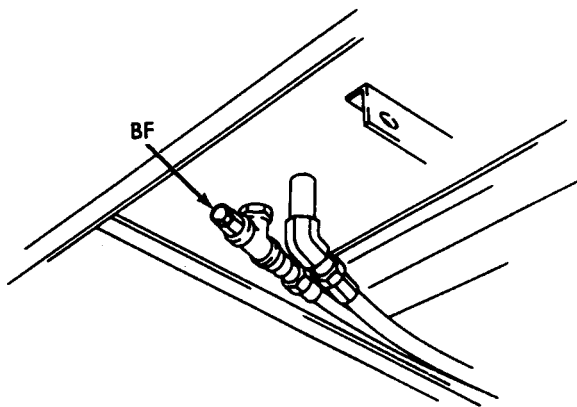

OIL RESERVOIR DRAIN

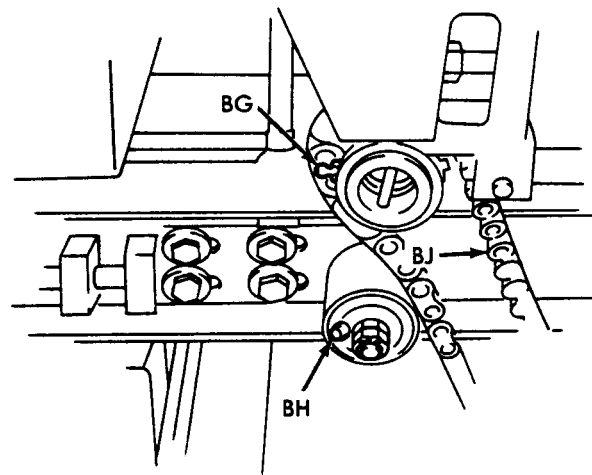

REAR WINCH
DRIVE CHAIN

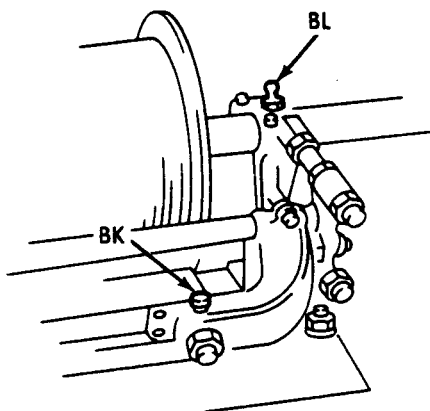

WINCH DRUM

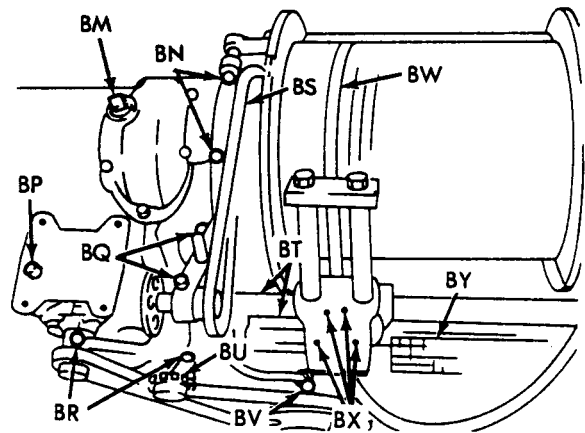

REAR WINCH

TA 252464

LOCALIZED LUBRICATION POINTS (BZ THROUGH CK)

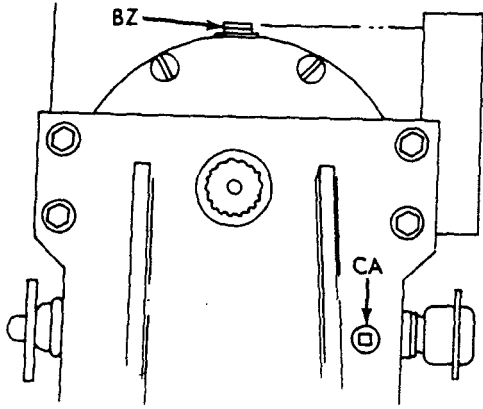

WORM GEAR HOUSING

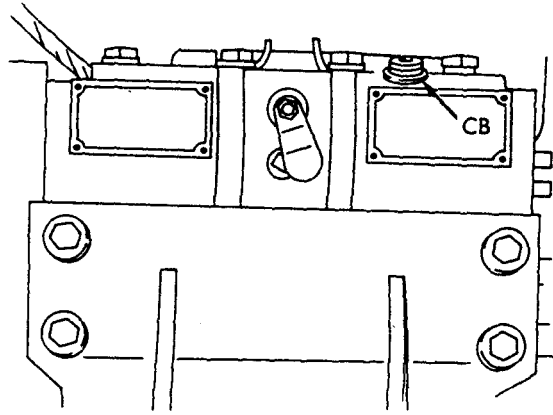

END FRAME HOUSING

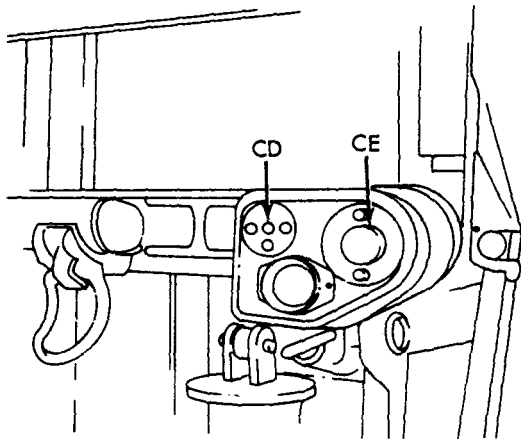

PIPELINE WINCH

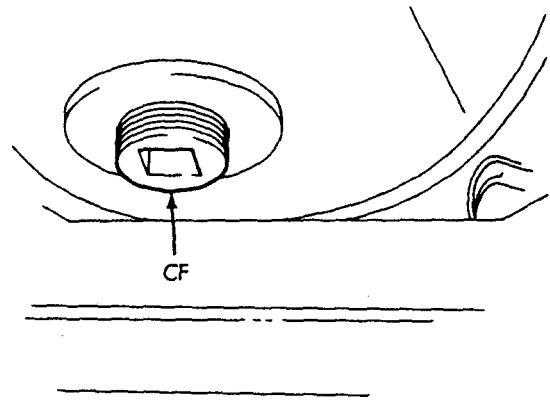

REAR WINCH

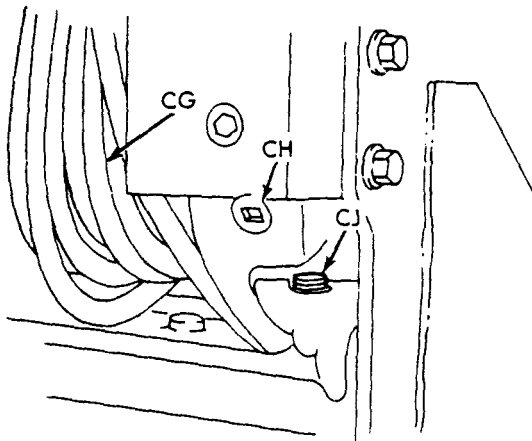

REAR WINCH

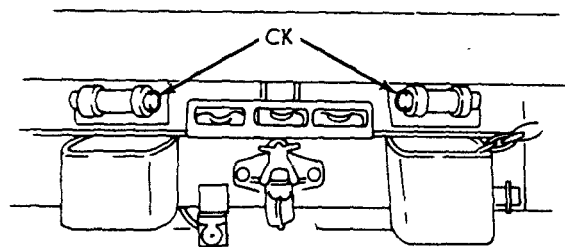

AUXILIARY ROLLER

TA 252465

NOTES

1. INTERVALS

This LO has been revised with DA program to extend intervals to conserve lubricants. This instruction applies only to vehicles in normal operation. Lubricate more frequently to compensate for abnormal or extreme conditions, such as high or low temperatures, emersion in water, or exposure to sand or dust. Lubricants which have become contaminated will be changed regardless of scheduled intervals. Points requiring lubrication at 3,000 miles (4,800 km) on vehicles not accumulating 3,000 miles (4,800 km) in a 6-month period, will be lubricated at time of Semiannual ("S") Preventive Maintenance Service. Points requiring lubrication at 6,000 miles (9,600 km) in a 6-month period, will be lubricated at least once a year. Points requiring lubrication at 12,000 miles (19,300 km) will be lubricated annually. When practicable, lubrication services will be made to coincide with the vehicle "S" Preventive Maintenance Service. For this purpose, a 10 percent tolerance (variation) in specified lubrication point mileage is permissible.

2. CRANKCASE BREATHER

Check and clean crankcase breather and lines every 6,000 miles (9,600 km) under normal operating conditions.

3. FUEL FILTERS

Drain primary fuel filter. If fuel filter contains dirt or water, drain secondary and final filters. If dirt or water is found in final filter, notify organizational maintenance. Replace primary and secondary filter elements and gaskets every 3,000 miles (4,800 km), 3 months, or 300 engine hours, whichever occurs first, or at the discretion of the Maintenance Officer, as local conditions warrant. Change final fuel filter during engine overhaul/rebuild or during troubleshooting. Do not drain filters completely.

4. OIL FILTER

Oil filters will be changed only when directed by the oil analysis laboratory. Remove filter drain plug and elements; clean inside of case, and reinstall drain plug, new elements, and gaskets.

5. CRANKCASE

a. Sample oil every 60 days or 1,000 miles (1,600 km). Army Reserve Units will sample every 120 days or 1,000 miles (1,600 km). Oil will be changed only when directed by oil analysis laboratory.

NOTE

- Submit oil samples as soon as they have been taken.
- AOAP does not do away with seasonal oil changes. Make oil changes as seasonal temperature requires.

TA 252466

NOTES (Cont'd)

5. (Cont'd)

To check engine oil level, wait at least one minute after shutting down engine to allow oil to drain into crankcase. Safe operating level is between ADD and FULL on dipstick. Do not overfill.

b. When vehicle or engine is placed in storage other than administrative storage, service the crankcase with grade 30 engine oil conforming to specification MIL-L-21260, Lubricating Oil, Internal Combustion Engine, Preservative and Break-In. Note that MIL-L-21260 engine oil is an operational lubricant and may be used until the initial scheduled oil change after reactivation of the vehicle or engine. For administrative storage, engine oil conforming to the specification and grade established by the KEY (see page 3) should be used.

6. GEAR CASES

Change gear lubricant only when required by maintenance repair action, or if contaminated by water or other foreign material. Semiannually, check lubricant for proper level and for contamination. Drain only when unit is hot after operation. At axle differentials, transfer case and transmission, check level to within 1/2-inch (12.70 mm) of level plug opening. Drain power takeoff at same time as transfer case. Level in winch end bearing frame housing right side is 6-7/8 inches (174.62 mm) below filler plug. Use the full level plug located on the left side on winch worm housing to check lubrication level.

NOTE

When a safe level of lubricant within a gear housing is indicated at time of scheduled lubrication, the lubricant retaining seal is functional, even though the seal may indicate questionable leakage. Questionable leaks that may indicate a defective seal will be subject to frequent observation as a potential problem area. When seepage or leakage of lubricant adversely affects the proper function of parts within the area (e.g. brakes), the retaining seal is non-functional regardless of lubricant level.

7. AUXILIARY EQUIPMENT GEAR CASES

Change gear lubricant only when required by maintenance repair action, contamination by water or other foreign material. Semiannually, check lubricant for proper level and for contamination. Drain only when hot after operation. Fill to plug or level cock before operation and after draining.

8. REAR SPRING SEAT BEARINGS OR BUSHINGS

a. Every 3,000 miles (4,800 km) or semiannually, whichever occurs first, remove pipe plug in bottom of spring seat and install fitting. Loosen screws on bearing cap. Lubricate with GAA grease through fitting until lubricant appears around cap. Tighten the screws on bearing cap. Remove fitting and reinstall pipe plug.

b. Every 6,000 miles (9,600 km), or annually, whichever occurs first, remove, clean, and inspect bearings. Reinstall bearings, tighten adjusting nuts and locknuts, and lubricate bearings as described in a. above.

NOTES (Cont'd)

9. DUMP BODY HYDRAULIC RESERVOIR

Seminannually, before checking oil level, slowly raise and lower body several times, and operate pump for one minute with body down to relieve system pressure before removing filler plug. Remove filler plug, gage, and screen. Clean and install screen. With body down, refill with oil to fourth mark from bottom on gage.

CAUTION

Do not overfill. Install filler plug. Again raise and lower body and operate pump for one minute with body down and recheck oil level. At semiannual PM service, remove pipe plug at bottom of reservoir and drain. Clean and install plug. Refill with approximately 4-1/2 gallons (17 l) of OE/HDO, and again raise and lower body and operate pump for one minute with body down and recheck oil level.

10. WINCH AND CRANE HOIST CABLES AND DRIVE CHAINS

After each day's operation, clean and oil with new OE/HDO. Semiannually, unwind entire cable, clean, and oil. At semiannual PM service, if cable is not generally used, unwind entire cable. Use a brush to clean, and soak with new OE/HDO. Wipe off excess, and coat with CW before rewinding cable on drum.

11. FRONT WHEEL UNIVERSAL JOINTS AND STEERING KNUCKLE BEARINGS

Every 12,000 miles (19,000 km), or annually, whichever occurs first, remove plug from universal joint housing, fill to level of plug opening, and reinstall plug. Remove plugs on each side of steering knuckle, and fill to level of plug opening through upper and lower steering knuckle bearings. Do not disassemble.

12. AUGER RACK

Remove dust and dirt from auger rack and from around rack thrust plate lower cage with clean cloth and wire brush after each day's operation. Coat auger rack with GAA grease.

13. BORING CASE (M764)

Drain only when hot after operating. Raise derrick tube to vertical position. Rotate case until derrick tube is parallel to ground. Remove access cover and drain case. Rotate case to normal position and fill to plug level. Install cover.

14. TEMPERATURE RISES

If the ambient temperature rises to +50°F (10°C) for no more than one week, use of OE/HDO or OEA is permissible.

15. REAR WINCH (M764)

a. Every week, or after 25 hours of winch operation, thoroughly clean the two level winder tie rods. After cleaning, coat both tie rods with clean engine oil.

b. Every month, or after 100 hours of operation, remove level winder cross-chain cover and brush GAA grease on carriage guide pin and wear plates.

TA 252468

NOTES (Cont'd)

16. OUTRIGGER OIL RESERVOIR AND DRIVE SHAFT (M764)

a. Semiannually, remove reservoir oil level gage and drain plug and drain lubricant from reservoir. Reinstall drain plug and fill reservoir with OE/HDO 10 engine oil to FULL mark on oil level gage with gage unscrewed. Extend and retract outrigger legs two or three times, then recheck oil level. Remove and clean filler neck screen.

b. Semiannually, remove the two rubber boot retaining rings from each rubber boot, and slide boots from overdrive shaft joint. Handpack each joint with GAA grease, then reinstall rubber boot. Replace damaged boot as required.

17. EARTH BORING MACHINE (M764) CLUTCH AND BRAKE CASE

Every week, or after 8 hours of operation, operate machine for 3 or 4 minutes with operating handle in NEUTRAL. Disengage power to machine, and immediately check oil level in housing with dipstick unscrewed. If necessary, replenish oil to FULL mark on dipstick with OE/HDO 10 or OEA engine oil in accordance with the temperature requirements in the KEY (see page 3).

18. STRAP SHEAVE, RIGGING BLOCK, AND DERRICK SHEAVE BUSHINGS (M764)

Remove sheave from housing, and coat inside of bushing with GAA grease.

19. MASTER CYLINDER ASSEMBLY

Service every 1,000 miles (1,600 km) or 6 months, whichever comes first. Use BFS (MIL-B-46176).

20. PINTLE

Vehicle received with TOW pintle without grease fittings is equipped with production improvement TOW pintle. This pintle is equipped with bushings, and does not require lubrication.

21. MILITARY SYMBOLS FOR LUBRICANTS

The following references are lubrication symbols used within this Lubrication Order to the appropriate specification:

OE/HDO - Lube Oil, ICE, MIL-L-2104
OEA - Lube Oil, ICE, Arctic, MIL-L-46167
GO - Lube Oil, Gear, Multipurpose, MIL-L-2105
GAA - Grease, Automotive and Artillery, MIL-G-10924
BFS - Fluid, Hydraulic Brake, MIL-B-46176
CW - Lube Oil, Chain, Exposed Gear and Wire Rope, VV-L-751

TA 252469

Copy of this lubrication order will remain with the vehicle at all times. Instructions contained herein are mandatory and supersede all conflicting lubrication instructions dated prior to the date of this lubrication order.

BY ORDER OF THE SECRETARY OF THE ARMY:

Official:

E. C. MEYER
General United States Army
Chief of Staff

ROBERT M. JOYCE
Major General United States Army
The Adjutant General

Distribution:

To be distributed in accordance with DA Form 12-38 LO requirements for Truck, 2-1/2 Ton, 6x6.

TA 252470