

ROUTINE

MWO effective date is 1 September, 1993, and completion date is 1 September, 1997.

MWO 9-2320-272-20-4

MODIFICATION WORK ORDER

MODIFICATION OF 5-TON

M936 and M936A1 SERIES TRUCKS

WRECKER AUTOMATIC THROTTLE KIT

NOMENCLATURE	NSN	EIC
Truck, Medium Wrecker	2320-01-047-8754	BTF
Truck, Medium Wrecker	2320-01-206-4078	BSG

Headquarters, Department of the Army, Washington, D.C.

27 July 1994

REPORTING OF ERRORS AND RECOMMENDING IMPROVEMENTS

You can help improve this MWO. If you find any mistakes or if you know of a way to improve these procedures, please let us know. Write a letter or complete and mail a DA Form 2028, Recommended Changes to Publications and Blank Forms, to: U.S. Army Tank-Automotive Command, ATTN: AMSTA-MB, Warren, MI 48397-5000. A reply will be provided to you.

DISTRIBUTION STATEMENT A. Approved for Public Release; Distribution is Unlimited.

1. PURPOSE.

The purpose of this modification is to provide an automatic throttle kit which increases engine RPM's automatically during operation of the crane.

2. PRIORITY.

This modification is classified as ROUTINE.

3. END ITEM TO BE MODIFIED.

a. 5-ton, 6x6, M936 and M936A1 series trucks.

NOMENCLATURE	NSN	EIC	PART NO.	CAGE CODE	MODEL NO.
Truck, Medium Wrecker	2320-01-047-8754	BTF	8736988	19207	M936
Truck, Medium Wrecker	2320-01-206-4078	BSG	8750163	19207	M936A1

b. Vehicle's National Stock Number (NSN) will not change as a result of this MWO.

4. MODULE TO BE MODIFIED.

Not applicable.

5. PARTS TO BE MODIFIED.

Not applicable.

6. APPLICATION.

a. Time compliance statement: MWO effective date is 1 September, 1993, and completion date is 1 September, 1997.

b. The lowest level of maintenance authorized to apply the MWO is unit maintenance.

c. Work force and man-hour requirements for application of the MWO to a single unit, end item, or system are as follows:

REQUIREMENTS	
WORK FORCE/SKILLS	MAN-HOURS
Two Wheeled Vehicle Mechanics (MOS 63B) or equivalent	4
Total man-hours required for a single application of this MWO is 8 hours.	

d. There is no other MWO that must be applied prior to the application of this MWO.

e. There is no additional information necessary to apply this MWO.

7. TECHNICAL PUBLICATIONS AFFECTED/CHANGED AS A RESULT OF THIS MWO.

<u>Technical Publication</u>	<u>Date</u>
TM 9-2320-272-10	25 July 1984
TM 9-2320-272-20	25 October 1985
TM 9-2320-272-20P	02 September 1988
TM 9-2320-272-34P	20 January 1988
TM 9-2320-358-24&P	17 October 1992

8. MWO KITS, PARTS, AND THEIR DISPOSITION.

a. The following kit is required to accomplish this modification. The security classification of the kit is unclassified. Shipping data is (estimated):

Weight 2 lbs.; Measurements 15-in. x 3.5-in. x 3-in.; Volume 0.09 cu. ft.

NSN	NOMENCLATURE	CAGEC	PART NO.
2910-01-290-0738	Automatic Throttle Kit	01201	12357085

b. Automatic Throttle Kit component parts are listed below. The listing is used to inventory the kit for completeness.

NSN	NOMENCLATURE	CAGEC	PART NO.	QTY.
3040-01-090-4483	Bellcrank Link Assembly	19207	12255965-2	1
3120-00-977-9056	Bushing	19207	12256573	2
xxxx-xx-xxx-xxxx	Bracket	xxxxx	12356928	1
xxxx-xx-xxx-xxxx	Plate, Data	xxxxx	12356929	1
xxxx-xx-xxx-xxxx	Air Cylinder	xxxxx	12356930	1
xxxx-xx-xxx-xxxx	Throttle Lever Assembly	xxxxx	12368325	1
4730-01-079-8821	Insert	19207	CPR102321-1	2
5975-00-451-5001	Strap, Retaining	96906	MS3367-3-9	2
5315-00-001-7875	Pin	96906	MS20392-3C25	2
5315-00-839-2325	Pin, Cotter	96906	MS24665-132	3
5315-00-842-3044	Pin, Cotter	96906	MS24665-283	1
5310-00-809-4058	Washer	96906	MS27183-10	6
5310-00-891-1758	Jamnut	96906	MS35691-6	1
5340-00-865-9496	Clevis	96906	MS35812-2	1
5305-00-432-8027	Screw	96906	MS51861-22	4
5306-01-112-4341	Screw	96906	MS90728-5L	4
4730-00-409-7854	Elbow	81343	6-2 120302BA	1
xxxx-xx-xxx-xxxx	Tee	xxxxx	6-6-6 120424BA	1

c. Bulk and expendable materials used to apply the Automatic Throttle Kit are listed below:

NSN	NOMENCLATURE	CAGEC	PART NO.	QTY.
9720-01-014-4915	Tubing	19207	CPR104420-2	24 in.
8030-00-753-4953	Pipe Sealant	19207	12302758	1
8040-00-221-3807	Adhesive	96906	MMM-A-1617	1

d. Parts disposition. All parts and materials removed and not reused during installation of kit will be returned to stock for disposition in accordance with AR 725-50.

e. The items listed below are not included in the Automatic Throttle Kit and must be requisitioned from stock:

NSN	NOMENCLATURE	CAGEC	PART NO.	QTY.
9905-00-858-5682	Plate, Instruction, MWO	19207	10930014	1
5305-00-253-5614	Drivescrew	96906	MS21318-20	1

9. SPECIAL TOOLS; TOOL KITS; JIG; TEST, MEASUREMENT, AND DIAGNOSTIC EQUIPMENT (TMDE); AND FIXTURES REQUIRED.

a. Hand tools necessary to apply MWO are contained in this tool kit:

NOMENCLATURE	NSN	CAGEC	SUPPLY CATALOG
Tool Kit, General Mechanic's	5180-00-177-7033	50980	SC 5180-90-CL-N26

b. Metal drilling equipment necessary to apply MWO is contained in this shop set:

NOMENCLATURE	NSN	CAGEC	SUPPLY CATALOG
Shop Equipment, Machine Shop: Field Maintenance Basic	3470-00-754-0708	19704	SC 3470-95-CL-A02

10. MODIFICATION PROCEDURES.

a. Vehicle Preparation.

- (1) Set parking brake (TM 9-2320-272-10).
- (2) Drain air reservoirs (TM 9-2320-272-10).
- (3) Remove air cleaner, air cleaner tube hose, air intake pipe, and pump hose assembly (TM 9-2320-272-20).
- (4) Remove accelerator pedal pushrod, return spring, ball joint, and throttle cable from bellcrank link assembly (TM 9-2320-272-20). Retain washer from accelerator pedal pushrod for use in task c., step 2.
- (5) Remove cotter pin, washer, throttle shaft, and bellcrank link assembly from throttle bracket as shown in figure 1.
- (6) Remove screw, two clamps, and air hoses from cab floor as shown in figure 1.
- (7) Install two air hoses on service brake air hoses with two MS3367-3-9 retaining straps as shown in figure 2.
- (8) Remove air supply line and elbow from air pressure switch tee as shown in figure 3.
- (9) Using driver's seat base plate as a reference, mark and cut a section of cab floor insulation from cab floor as shown in figure 4.
- (10) Fold back section of cab floor insulation, locate, mark, and drill four 0.281-inch diameter holes in cab floor as shown in figure 5.

b. Automatic Throttle Kit Preparation.

- (1) Install two 12256573 bushings and 12368325 throttle lever assembly on 12255965-2 bellcrank link assembly as shown in figure 6.
- (2) Apply 12302758 pipe sealant to threads of 6-2 120302BA elbow and install elbow (6-2 120302BA) in port of 12356930 air cylinder as shown in figure 7.
- (3) Install MS35691-6 jamnut and MS35812-2 clevis on air cylinder rod. Leave a 0.250-inch gap between jamnut (MS35691-6) and air cylinder (12356930) as shown in figure 7. Tighten jam nut against clevis 10 lb-ft (14 N·m).

c. Automatic Throttle Kit Installation.

- (1) Position accelerator pedal pushrod on bellcrank link/throttle lever assembly and install bellcrank link/throttle lever assembly on throttle bracket with throttle shaft, washer, and MS24665-283 cotter pin as shown in figure 8.
- (2) Install accelerator pedal pushrod on bellcrank link/throttle lever assembly with washer and MS24665-132 cotter pin as shown in figure 8.
- (3) Install ball joint, return spring, and throttle cable on bellcrank link assembly (12255965-2) (TM 9-2320-272-20).
- (4) Install 12356928 bracket on cab floor with four MS27183-10 washers and MS90728-5L screws as shown in figure 9.
- (5) Install air cylinder (12356930) on bracket (12356928) with MS20392-3C25 straight-headed pin, MS27183-10 washer, and MS24665-132 cotter pin as shown in figure 9.
- (6) Install clevis (MS35812-2) on throttle lever assembly (12368325) with MS20392-3C25 straight-headed pin, MS27183-10 washer, and MS24665-132 cotter pin as shown in figure 9.
- (7) Measure clearance between stud of bellcrank link assembly (12255965-2) and throttle lever assembly (12368325). Clearance should be 0.06-0.08-inch as shown in figure 9.

NOTE

Perform steps 8 through 11 if clearance is not within limits.

- (8) Remove cotter pin (MS24665-132), washer (MS27183-10), straight-headed pin (MS20392-3C25), and clevis (MS35812-2) from throttle lever assembly (12368325) as shown in figure 9.
- (9) Loosen jamnut (MS35691-6) and turn clevis (MS35812-2) to obtain proper clearance as shown in figure 9.
- (10) Install clevis (MS35812-2) on throttle lever assembly (12368325) with straight-headed pin (MS20392-3C25), washer (MS27183-10), and cotter pin (MS24665-132). Check clearance as shown in figure 9.
- (11) Repeat steps 8 through 10 until proper clearance is obtained.
- (12) Install CPR102321-1 insert, sleeve, and CPR104420-2 tubing on elbow (6-2 120302BA) on air cylinder (12356930) with nut as shown in figure 9.

MWO 9-2320-272-20-4

- (13) Apply 12302758 pipe sealant to threads of 6-6-6 120424BA tee and install tee (6-6-6 120424BA) on air pressure switch tee. Connect air supply line to tee (6-6-6 120424BA) as shown in figure 10.
- (14) Route tubing (CPR104420-2) to tee (6-6-6 120424BA) and cut to length as shown in figure 10.
- (15) Install CPR102321-1 insert, sleeve, nut, and tubing (CPR104420-2) on tee (6-6-6 120424BA) as shown in figure 10.
- (16) Apply MMM-A-1617 adhesive to cab floor and install cab insulation flap as shown in figure 11.
- (17) Remove four screws and operation data plate from gondola crane operator panel as shown in figure 12, Discard screws and operation data plate.
- (18) Install 12356929 operation data plate on gondola crane operator panel with four MS51861-22 screws as shown in figure 12.
- (19) Remove four screws and caution plate from driver's door as shown in figure 13.

d. Vehicle Equipment.

- (1) Install air intake pipe and pump hose assembly, air cleaner tube hose, and air cleaner (TM 9-2320-272-20).
- (2) Check adjustment of fuel pump throttle lever rod (TM 9-2320-272-20).
- (3) Start engine and engage transfer case PTO (TM 9-2320-272-10).
- (4) Check for air leaks and smooth operation of air cylinder (12356930).
- (5) Check vehicle and crane operation (TM 9-2320-272-10).

11. CALIBRATION REQUIREMENTS.

Not applicable to this MWO.

12. WEIGHT AND BALANCE DATA,

Weight and balance are not significantly affected by this MWO.

13. QUALITY ASSURANCE REQUIREMENTS.

a. General. The following information is supplied to ensure the proper application of this modification and provide clarification in regard to the adequacy of the installer's inspection methods and procedures applicable to quality assurance. The procedures include, but are not limited to, installer responsibilities, government verification, and in-process and workmanship inspections. Inspections shall be in accordance with TM 750-245-4.

b. Installer Responsibilities. The installer is responsible for compliance with quality assurance requirements specified herein. These requirements and the installer's plan of inspection, or quality program, constitute the minimum examinations and tests necessary to assure compliance with established requirements. Requirements contained in this MWO shall be included in the installer's inspection plan or quality program. These requirements shall not be construed as eliminating the installer's responsibility from complete compliance with all provisions of the contract. Specific installer responsibilities for modification work order are as follows: The installer is responsible for following instructions contained in this MWO, for installation of the Automatic Throttle Kit, and for follow-on tasks IAW MWO 9-2320-272-20-4, Installer is responsible for notifying the Government representative if kit was received incomplete or received in open or damaged condition. The installer is responsible for quality workmanship.

c. In-Process Inspection. During normal assembly operations, paragraph 10, Modification Procedures, will be used to check the installer's work. If air cylinder fails to operate properly after kit installation, servicing will be conducted in accordance with PMCS procedures found in TM 9-2320-272-10. All defects will be corrected by the installer before the vehicle is placed in service. All vehicles modified during a production shift will be checked to ensure product quality.

d. Workmanship Inspection. Inspect components removed, installed, or replaced during the modification for security of mounting. Inspect painted areas of cab for missing, chipped, or cracked paint and correct if necessary.

14. RECORDING AND REPORTING OF THE MODIFICATION.

a. Records and Report Forms. Refer to DA PAM 738-750, DA PAM 738-751, and TB 9-1100-803-15.

b. Marking Equipment.

- (1) After the Automatic Throttle Kit is installed, mark MWO number "9-2320-272-20-4" and date applied in the MWO and date blocks on 10930014 MWO Instruction Plate as shown in figure 14.
- (2) Install MWO data plate by drilling a hole (#37 drill) in cab body reinforcement panel and secure with MS21318-20 drivescrew as shown in figure 14.
- (3) After drivescrew (MS21318-20) is installed, flatten or remove protruding excess drivescrew material from inside of cab body reinforcement panel.

15. MATERIAL CHANGE (MC) NUMBER.

This MWO is authorized by MC number 1-88-06-4195.

16. MODIFICATION IDENTIFICATION.

a. When installed correctly, the Automatic Throttle Kit will appear as shown in figure 9.

b. After the Automatic Throttle Kit is installed, the air cylinder should be tested for proper operation. Any faults detected, or discrepancies noted, will be corrected before the vehicle is returned to normal service.

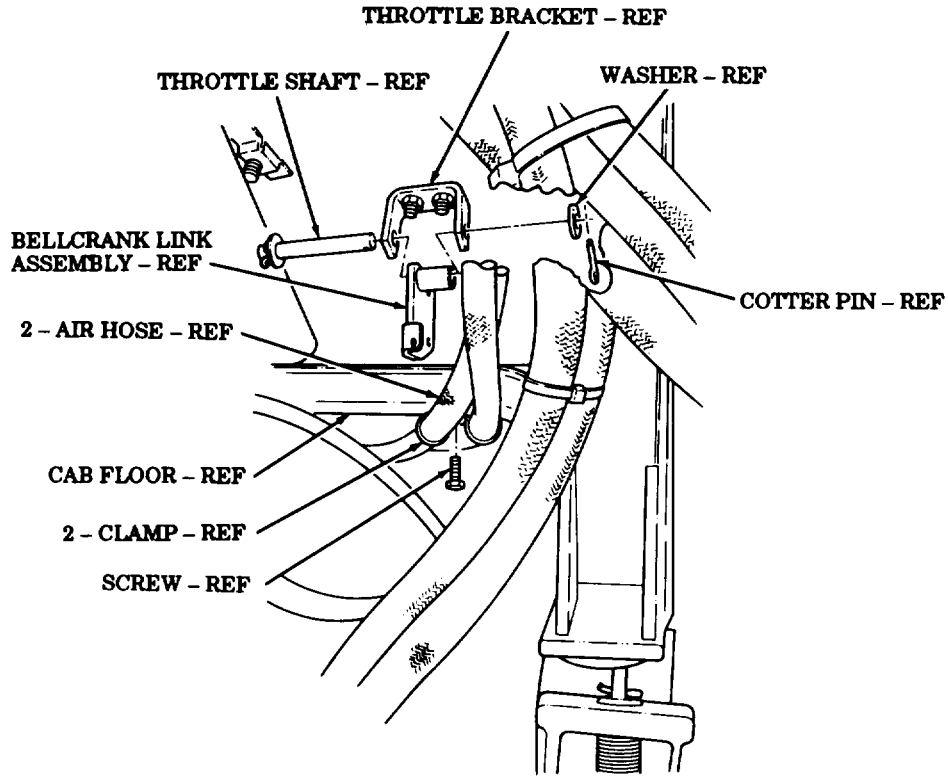

FIGURE 1

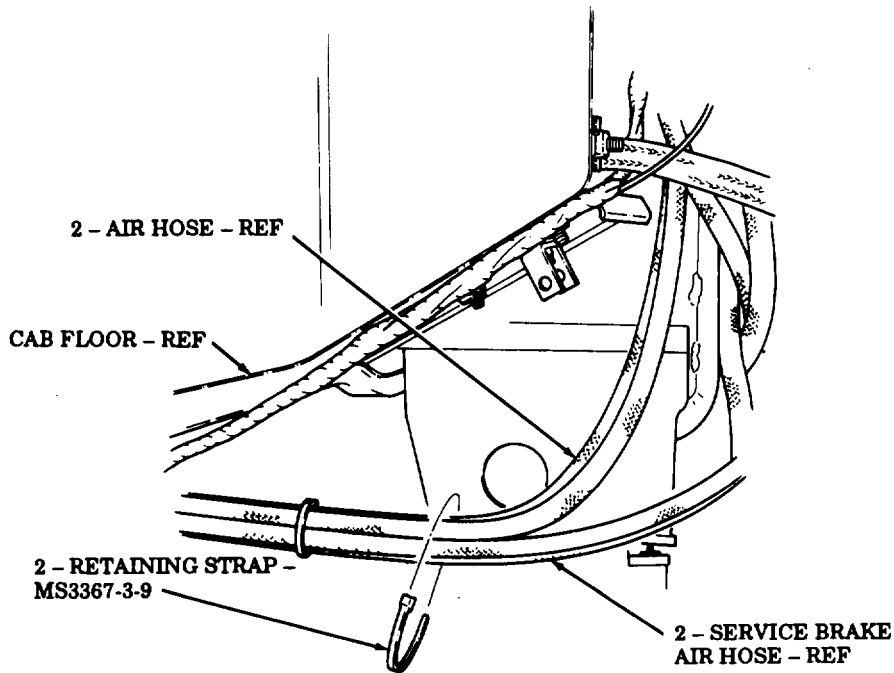

FIGURE 2

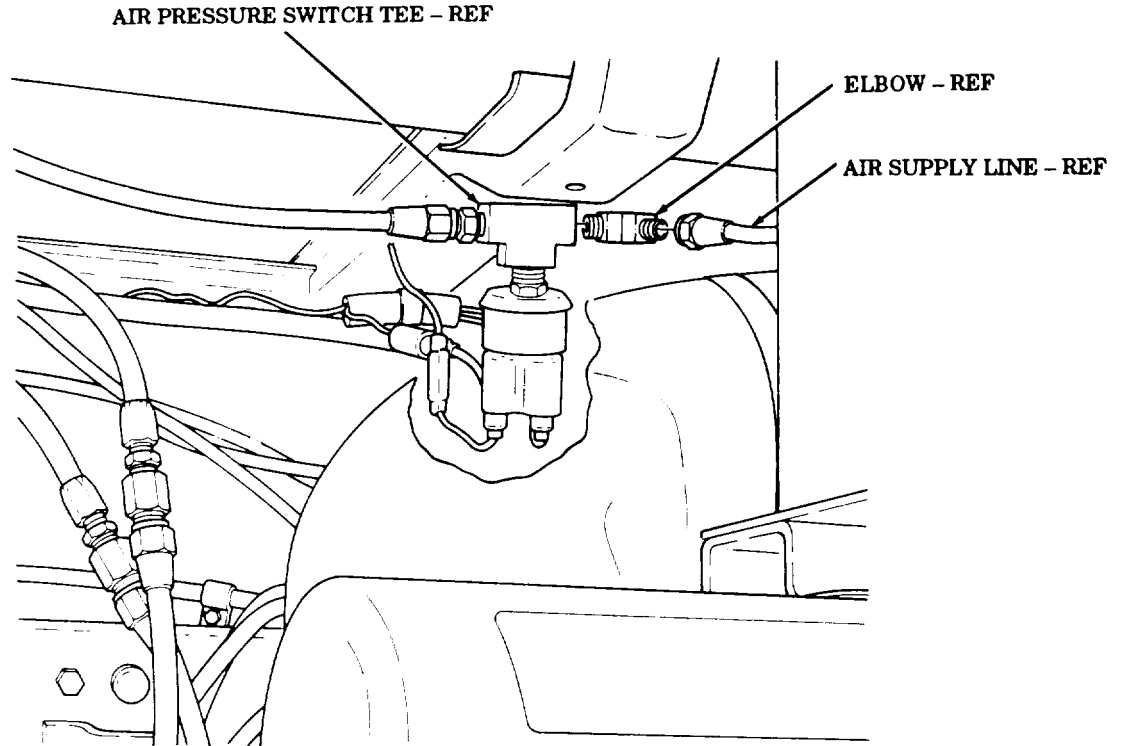

FIGURE 3

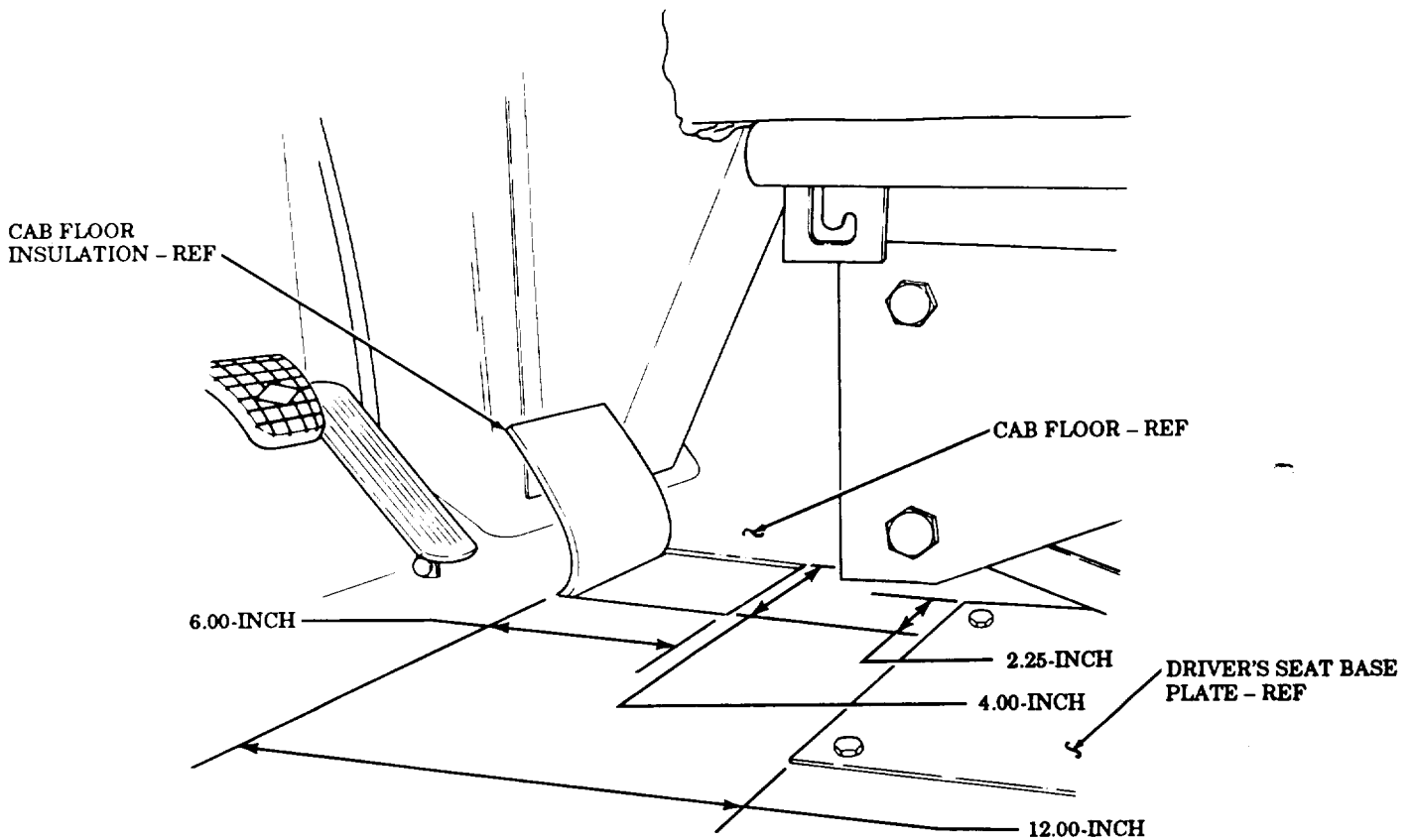

FIGURE 4

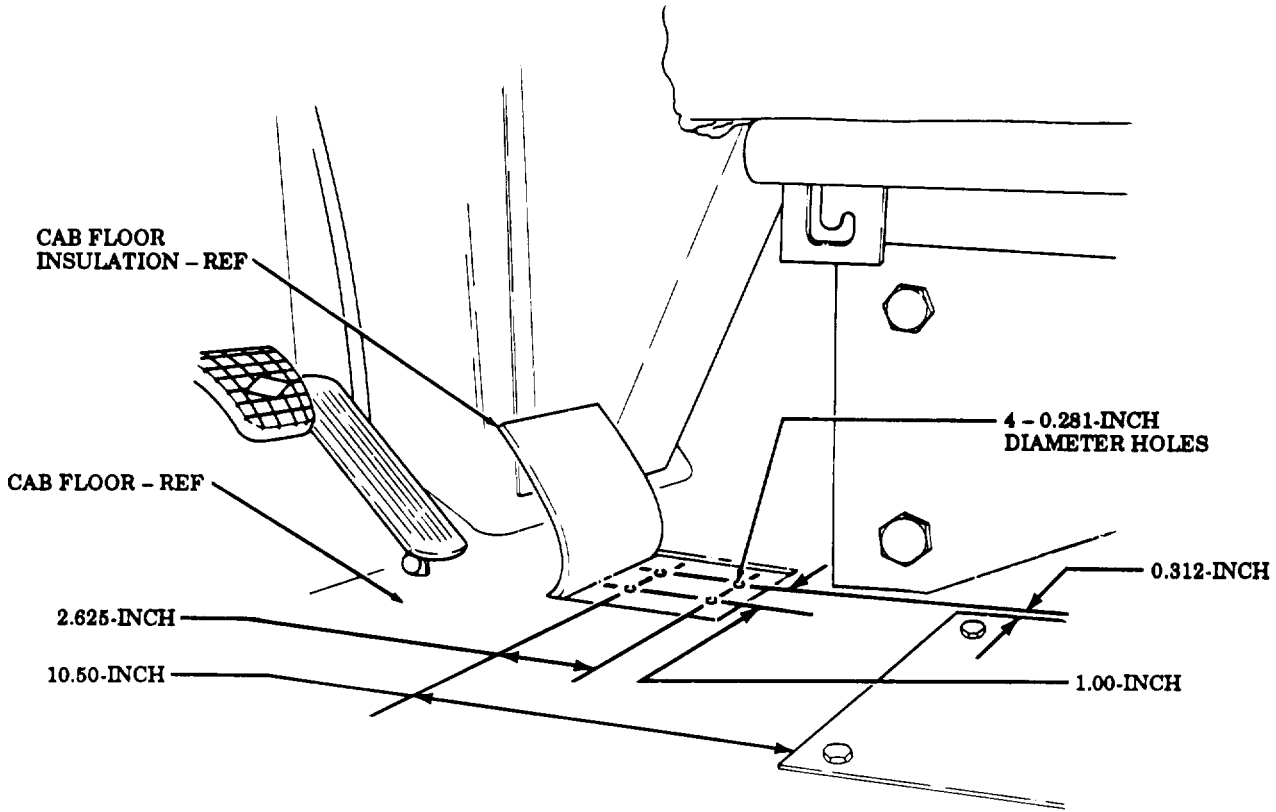

FIGURE 5

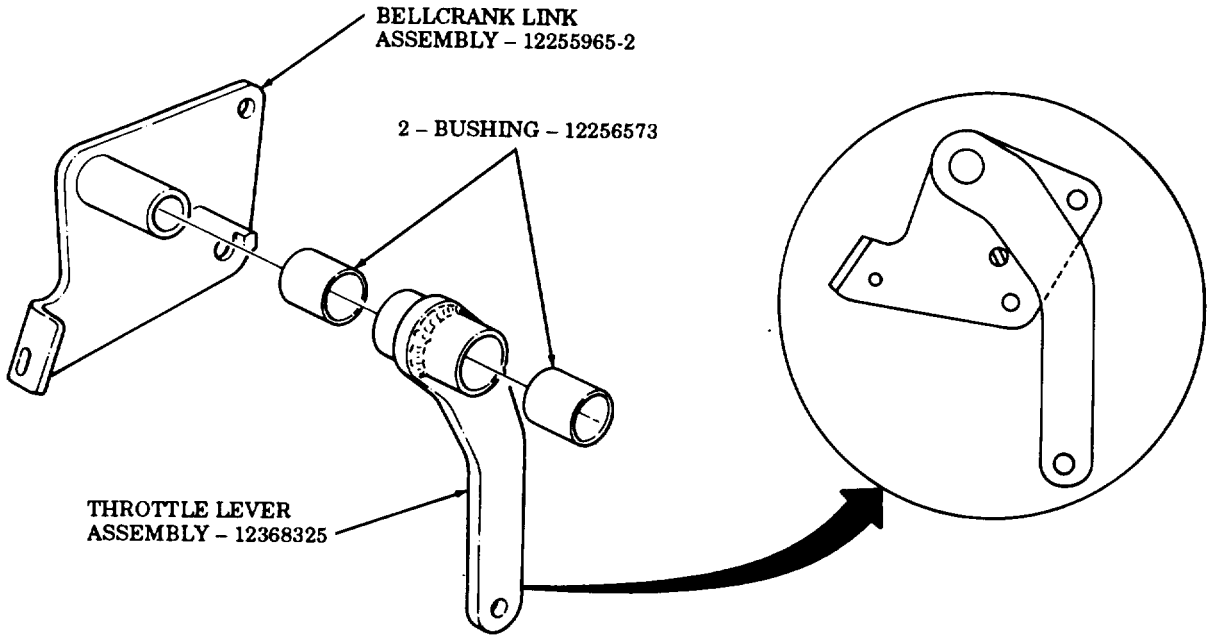

FIGURE 6

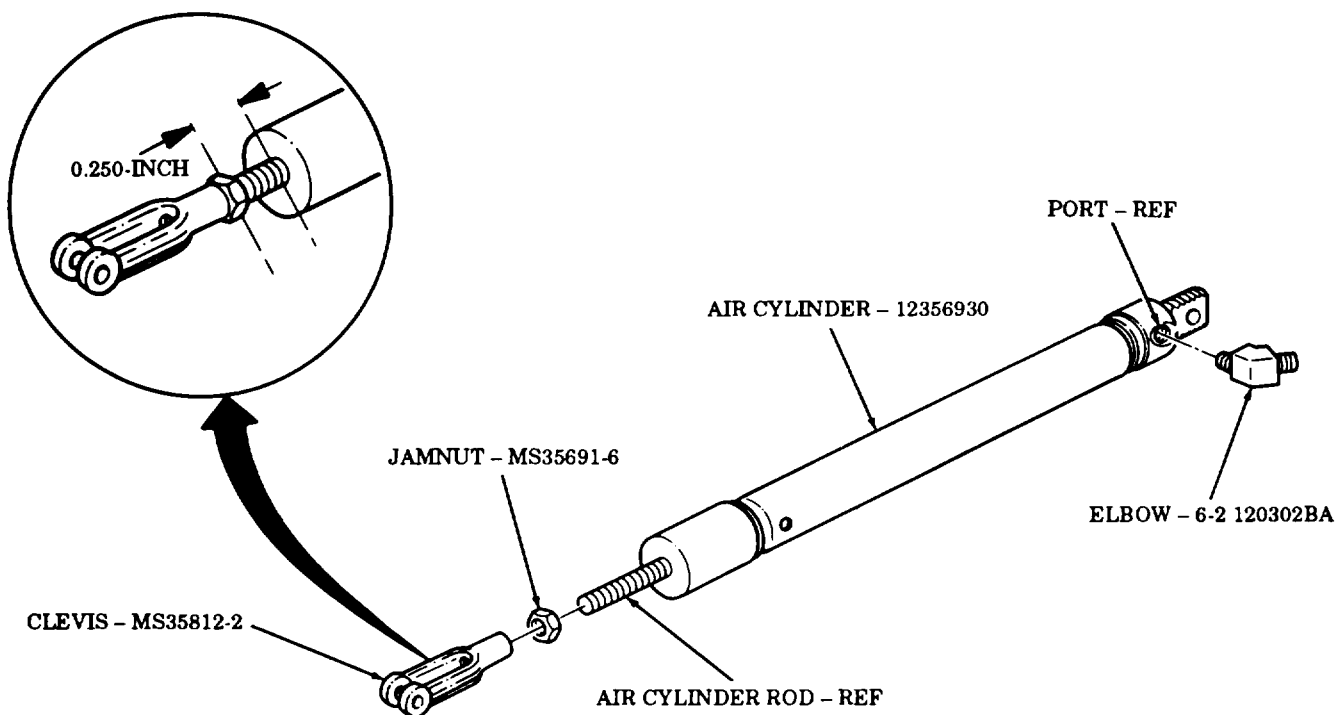

FIGURE 7

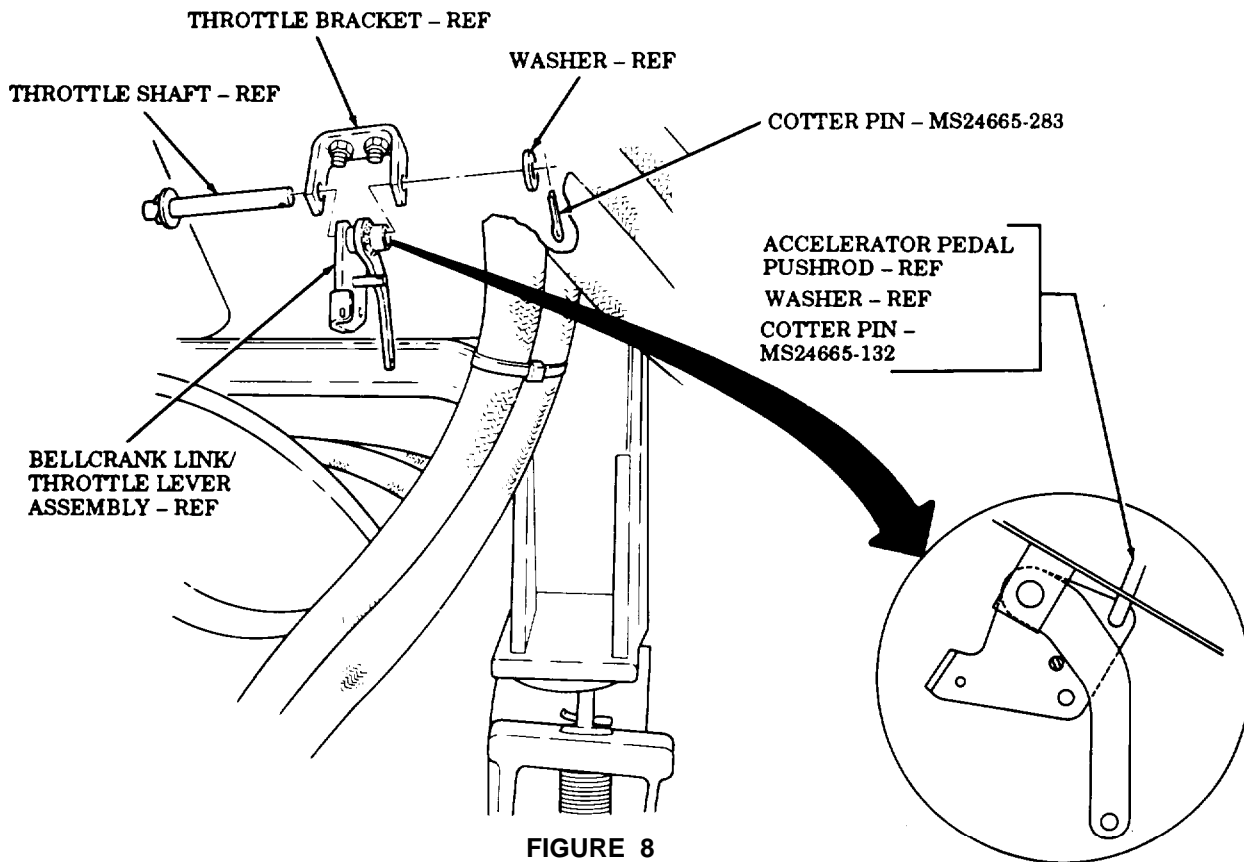

FIGURE 8

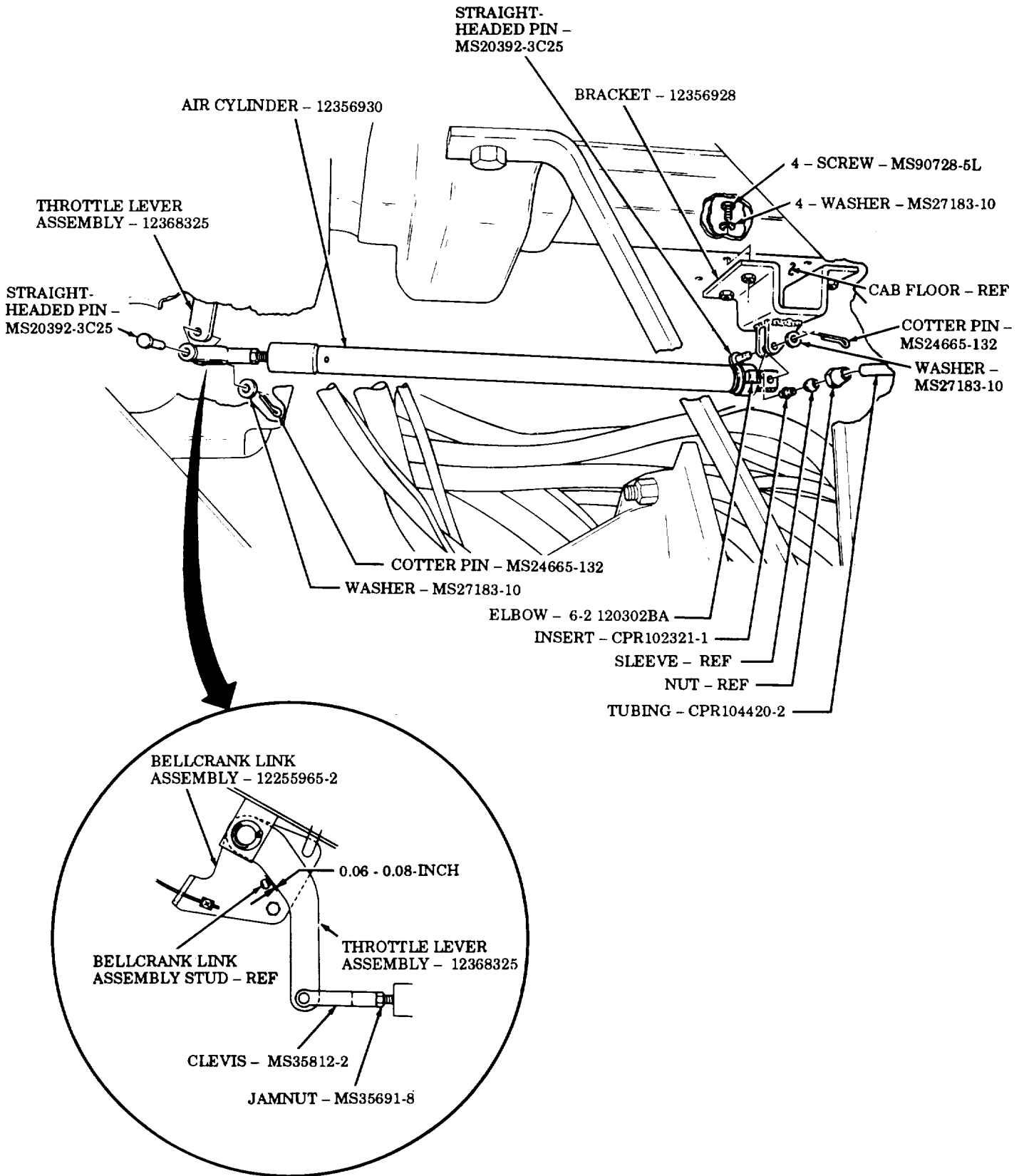

FIGURE 9

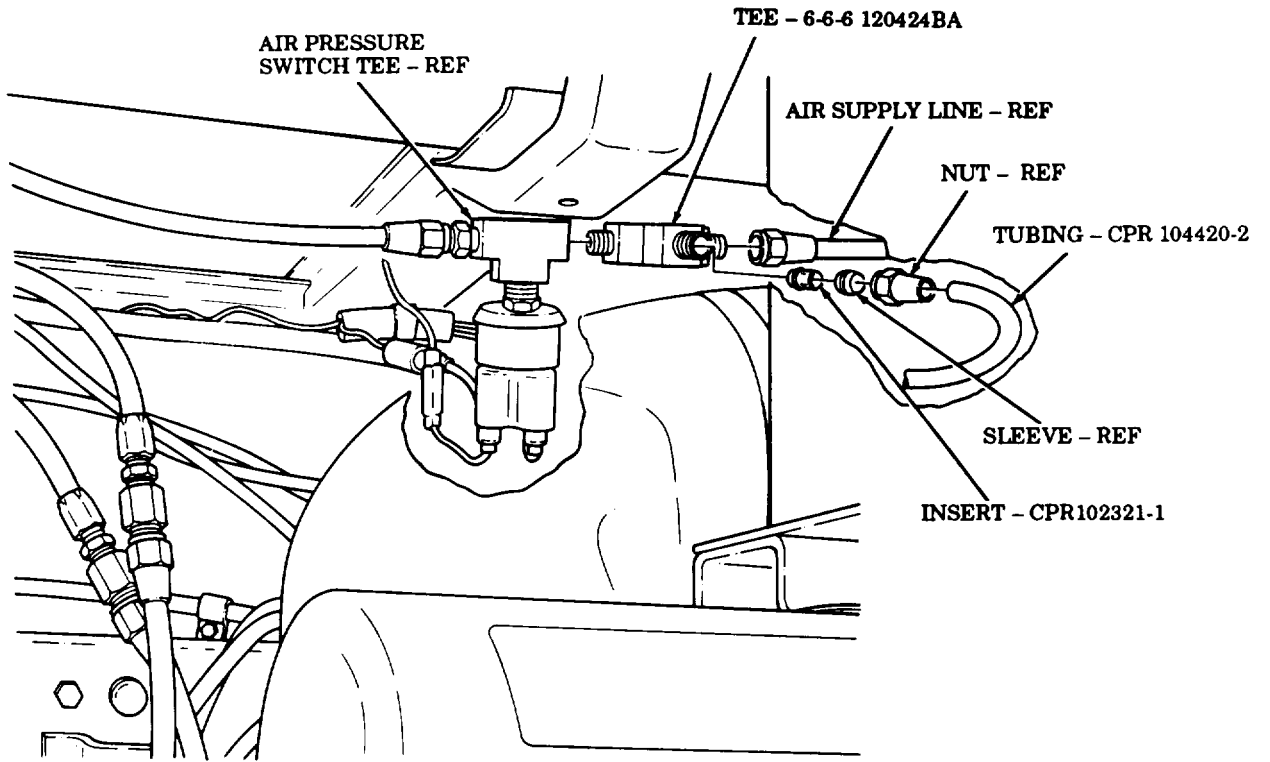

FIGURE 10

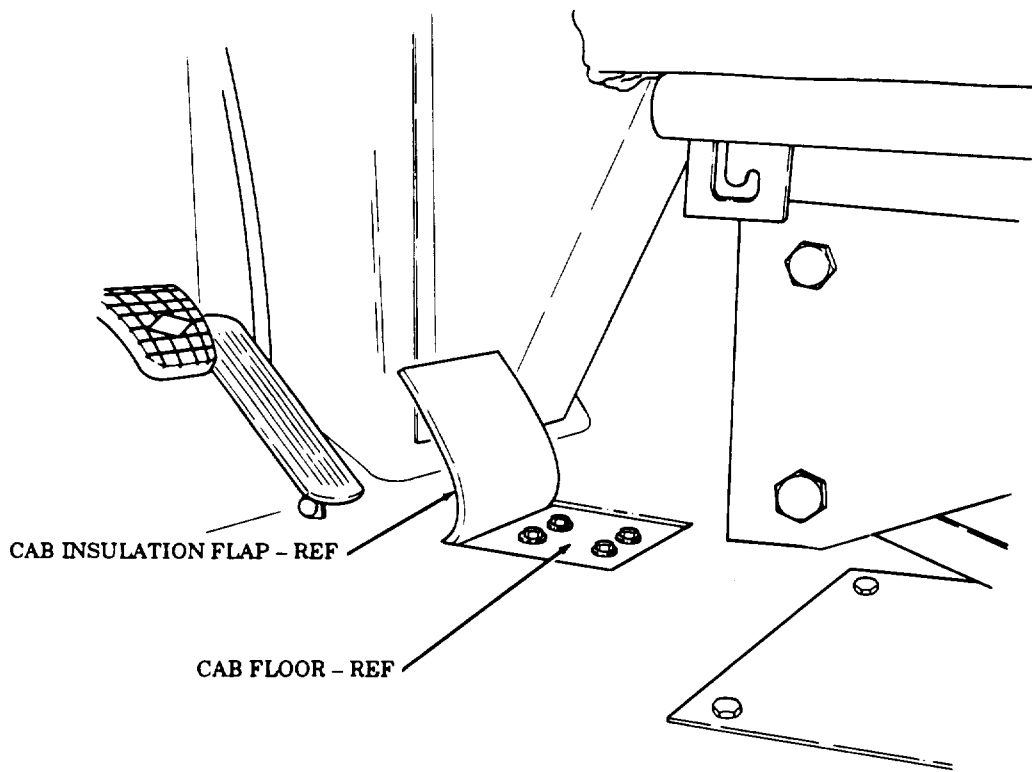

FIGURE 11

MWO 9-2320-272-20-4

4 - SCREW - REF
4 - SCREW - MS51861-22

OPERATION DATA PLATE
PLATE - 12356929

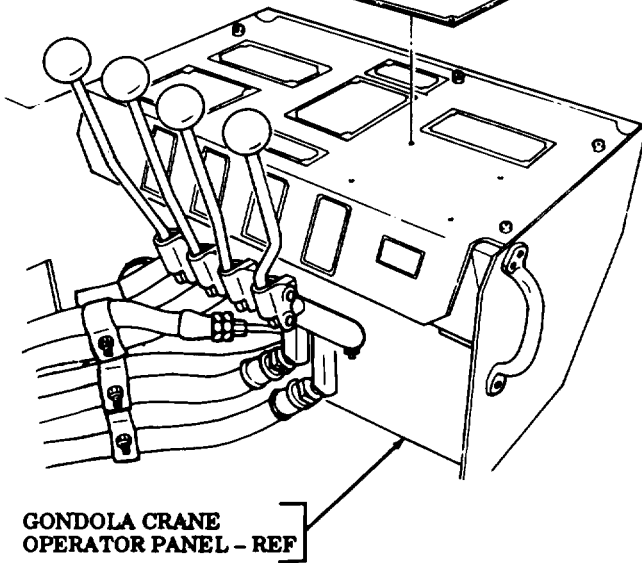
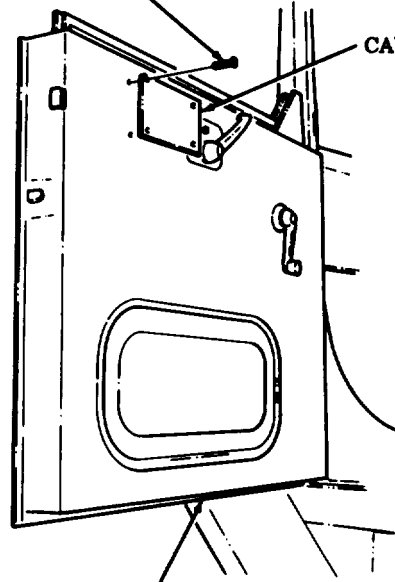

FIGURE 12

4 - SCREW

CAUTION PLATE



DRIVER'S DOOR - REF

FIGURE 13

CAB BODY REINFORCEMENT
PANEL - REF

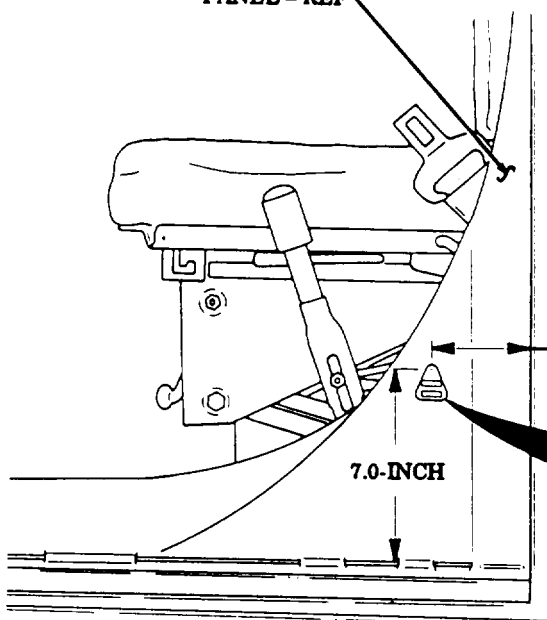

MWO INSTRUCTION
PLATE - 10930014
DRIVESCREW -
MS21318-20

3.5-INCH

7.0-INCH

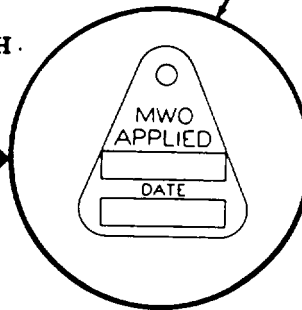
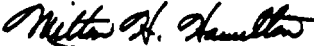

FIGURE 14

By Order of the Secretary of the Army:

GORDON R. SULLIVAN
General, United States Army
Chief of Staff

Official:

MILTON H. HAMILTON
Administrative Assistant to the
Secretary of the Army
07079

Distribution:

To be distribution in accordance with DA Form 12-38-E (Block 0999) requirements for MW09-2320-272-20-4.

RECOMMENDED CHANGES TO EQUIPMENT TECHNICAL PUBLICATIONS



THEN...JOT DOWN THE DOPE ABOUT IT ON THIS FORM, CAREFULLY TEAR IT OUT, FOLD IT AND DROP IT IN THE MAIL.

SOMETHING WRONG WITH THIS PUBLICATION?

FROM: (PRINT YOUR UNIT'S COMPLETE ADDRESS)
YOUR MAILING ADDRESS

DATE SENT DATE YOU FILLED OUT THIS FORM

PUBLICATION NUMBER
MWO 9-2320-272-20-4

PUBLICATION DATE
FROM FRONT
COVER

PUBLICATION TITLE
MODIFICATION OF 5-TON M936
AND M936A1 SERIES TRUCKS

BE EXACT PIN-POINT WHERE IT IS

PAGE NO	PARA-GRAPH	FIGURE NO	TABLE NO
5	C		

IN THIS SPACE TELL WHAT IS WRONG AND WHAT SHOULD BE DONE ABOUT IT:

We found it helpful to remember 1/16th is .0625 while performing the adjustment described in steps 8 to 11.

SAMPLE

PRINTED NAME, GRADE OR TITLE, AND TELEPHONE NUMBER
Timothy M. Caldwell, CWO2
AUTOVON 424-8023; Comm 287-8023

SIGN HERE
Timothy M. Caldwell

TEAR ALONG PERFORATED LINE

REVERSE OF DA FORM 2028-2

SAMPLE

FILL IN YOUR
UNIT'S ADDRESS

FOLD BACK

DEPARTMENT OF THE ARMY

YOUR MAILING ADDRESS

OFFICIAL BUSINESS
PENALTY FOR PRIVATE USE \$300

Commander
US Army Tank-Automotive Command
ATTN: AMSTA-MB
Warren, MI 48397-5000

TEAR ALONG PERFORATED LINE

RECOMMENDED CHANGES TO EQUIPMENT TECHNICAL PUBLICATIONS



THEN...JOT DOWN THE DOPE ABOUT IT ON THIS FORM, CAREFULLY TEAR IT OUT, FOLD IT AND DROP IT IN THE MAIL.

SOMETHING WRONG WITH THIS PUBLICATION?

FROM: (PRINT YOUR UNIT'S COMPLETE ADDRESS)

DATE SENT

PUBLICATION NUMBER

MWO 9-2320-272-20-4

PUBLICATION DATE

27 July 1994

PUBLICATION TITLE

MODIFICATION OF 5-TON M936 AND M936A1 SERIES TRUCKS

BE EXACT PIN-POINT WHERE IT IS

PAGE NO	PARA-GRAPH	FIGURE NO	TABLE NO

IN THIS SPACE TELL WHAT IS WRONG AND WHAT SHOULD BE DONE ABOUT IT:

PRINTED NAME, GRADE OR TITLE, AND TELEPHONE NUMBER

SIGN HERE

DA FORM 1 JUL 79 2028-2

PREVIOUS EDITIONS ARE OBSOLETE.

P.S.—IF YOUR OUTFIT WANTS TO KNOW ABOUT YOUR RECOMMENDATION MAKE A CARBON COPY OF THIS AND GIVE IT TO YOUR HEADQUARTERS.

TEAR ALONG PERFORATED LINE

REVERSE OF DA FORM 2028-2

FILL IN YOUR
UNIT'S ADDRESS

FOLD BACK

DEPARTMENT OF THE ARMY

OFFICIAL BUSINESS
PENALTY FOR PRIVATE USE \$300

Commander
US Army Tank-Automotive Command
ATTN: AMSTA-MB
Warren, MI 48397-5000

TEAR ALONG PERFORATED LINE

