

DEPARTMENT OF THE ARMY TECHNICAL BULLETIN

SHOP EQUIPMENT, AUTOMOTIVE MAINTENANCE AND REPAIR,

ORGANIZATIONAL MAINTENANCE

(NSN 4910-00-754-0650)

INSTALLATION IN ONE M35A2 CARGO TRUCK

AND

ONE M105A2 CARGO TRAILER

HEADQUARTERS, DEPARTMENT OF THE ARMY

16 JANUARY 1984

CHANGE

HEADQUARTERS
DEPARTMENT OF THE ARMY

No. 1

Washington, DC, 23 December 1987

SHOP EQUIPMENT, AUTOMOTIVE MAINTENANCE AND REPAIR,
ORGANIZATIONAL MAINTENANCE
(NSN 4910-00-754-0650)
INSTALLATION IN ONE M35A2 CARGO TRUCK,
AND
ONE M105A2 CARGO TRAILER

TB 9-4910-745-30, 16 January 1984, is changed as follows:

1. Remove old pages and insert new pages as indicated below. New or changed material is indicated by a vertical bar to the left of the changed material. Changed illustrations are indicated by a miniature pointing hand highlighting the general area of the change.

Remove Pages

29 through 32
35 and 36

Insert Pages

29 through 32
35 and 36

2. File this change sheet in back of the publication for reference purposes.

By Order of the Secretary of the Army:

CARL E. VUONO
General United States Army
Chief of Staff

Official:

R. L. DILWORTH

Brigadier General, United States Army
The Adjutant General

DISTRIBUTION:

To be distributed in accordance with DA Form 12-21, requirements for FSC
4910: Motor Vehicle, Repair Shop Specialized Equipment.

WARNING

All electrically powered tools and equipment must be grounded prior to use.

TECHNICAL BULLETIN }
 No. 9-4910-745-30*)

HEADQUARTERS
 DEPARTMENT OF THE ARMY
 WASHINGTON, DC, 16 January 1984

SHOP EQUIPMENT, AUTOMOTIVE MAINTENANCE AND REPAIR,
 ORGANIZATIONAL MAINTENANCE
 (NSN 4910-00-754-0650)
 INSTALLATION IN ONE M35A2 CARGO TRUCK
 AND
 ONE M105A2 CARGO TRAILER

Reporting Errors and Recommending Improvements

You can help improve this bulletin. If you find any mistakes or if you knew of a way to improve the procedures, please let us know. Mail your letter or DA Form 2028 (Recommended Changes to Publications and Blank Forms) direct to: Commander, US Army Armament, Munitions and Chemical Command, ATTN: DRSMC-MAS(R), Rock Island, IL 61299. A reply will be furnished to you.

TABLE OF CONTENTS

Para		Page
1	GENERAL	1
2	LOCATION OF EQUIPMENT	1
3	INSTALLATION	9

LIST OF ILLUSTRATIONS

Figure	Title	Page
1	Cargo truck, M35A2, unit 1	15
2	Components to be mounted, unit 1, M35A2	16
3	Hole dimensions for mounting components, unit 1, M35A2, floor plan	17
4	Hole dimensions for blind rivet nuts, unit 1, M35A2, right side elevation	18

*This bulletin supersedes TB ORD 5100-30/3, dated 4 Dec 1958.

LIST OF ILLUSTRATIONS --Continued

Figure	Title	Page
5	Hole dimensions for strap loops, unit 1, M35A2, right side elevation	19
6	Components to be mounted, unit 1, M35A2, left side elevation	20
7	Hole dimensions for blind rivet nuts and strap loops, unit 1, M35A2, left side elevation	21
8	Cargo trailer, M105A2, unit 2	22
9	Components to be mounted, unit 2, M105A2	23
10	Hole dimensions for 74-in. support angle and strap loops, unit 2, M105A2, floor plan	24
11	Components to be mounted, unit 2, M105A2, right side elevation	25
12	Hole dimensions for blind rivet nuts and strap loops, unit 2, M105A2, right side elevation	26
13	Components to be mounted, unit 2, M105A2, left side elevation	27
14	Hole dimensions for blind rivet nuts and strap loops, unit 2, M105A2, left side elevation	28
15	Electrical components to be mounted, unit 1, M35A2, floor plan	29
16	Electrical components to be mounted, unit 1, M35A2, right side elevation	30
17	Electrical components to be mounted, unit 1, M35A2, left side elevation	31
18	Electrical schematic, unit 1, M35A2	32
19	Power cable assembly, 11021163, unit 1, M35A2	33
20	Power cable assembly, 11021164, unit 1, M35A2	34
21	Power cable assembly, 11021165, unit 1, M35A2	35
22	Power cable assembly, 11021166, unit 1, M35A2	36
23	Support angles, units 1 and 2, M35A2 and 105A2	37

*This bulletin supersedes TB ORD 5100-30/3, dated 4 Dec 1958.

1. General

a. The instructions in this bulletin are to be used only as advice and guidance for installation of organizational maintenance automotive maintenance and repair shop equipment (NSN 4910-00-754-0650) in one M35A2 cargo truck, unit 1, and one M105A2 cargo trailer, unit 2.

b. Slight variations to installation instructions may be made in accordance with FM 55-30 at the discretion of the officer in charge.

c. Complete list of items contained in this shop is found in SC 4910-95-CL-A72.

WARNING

All electrically powered tools and equipment must be grounded prior to use.

CAUTION

Special care should be exercised to avoid damage to electrical connectors, wiring, or electrical equipment.

d. Personnel performing this installation should have practical knowledge of electricity.

e. Items not mentioned in this bulletin, that may be components of this shop, may be stowed in cabinets and drawers or secured in such a manner as to avoid damage in transit.

CAUTION

To preserve waterproof characteristics, precautions should be taken not to puncture the outer skin when drilling holes in walls of shop. Coat underside of vehicle body with coating compound (UNDERCOATING TT-C-520, NSN 8030-00-221-1883) where mounting hardware projects through floor.

f. All dimensions, fastener sizes, and hardware sizes are in inches.

g. When entering shop, curbside is at right and roadside is at left.

2. Location of Equipment

a. Locations of equipment to be installed or stowed in units 1 and 2 are referenced in figures 1 thru 14.

b. Refer to table 1 for hardware required for installation.

c. Refer to table 2 for components to be mounted.

d. Refer to table 3 for electrical components to be mounted.

e. Refer to table 4 for drill diameter conversion chart.

2. Location of Equipment--Continued

Table 1. Mounting Hardware

MS/part no.	Size and description	Qty	Application
MS3367-3	Strap, Tiedown, 12.00 in. L	28	Power cable assemblies
MS20601-MP6W4	3/16 Blind Rivet x 13/32 L	4	Strap loops for tool box installation
MS27130-A27	#10-24 UNC Blind Rivet Nut x 51/64 L	22	Walls and floors for strap loop installation
MS27183-9	1/4 Flat Washer	32	Tube-pipe fitting kit, strap loops
MS27183-11	5/16 Flat Washer	3	Utility grinding machine
MS27183-13	3/8 Flat Washer	14	Storage cabinets, 1.5-kw generator sets
MS27183-14	13/32 Flat Washer	8	Power cable assemblies, special purpose cable assembly, special purpose cable kit, rubber hose assemblies
MS27183-17	1/2 Flat Washer	4	Machinist's vise
MS27183-42	7/32 Flat Washer	18	Strap loops
MS35190-275	#10-24 UNC-2A Countersunk Head Machine Screw x 1.00 L	32	Strap loops
MS35190-276	#10-24 UNC-2A Countersunk Head Machine Screw x 1-1/4 L	42	Strap loops
MS35338-43	#10 Lockwasher	18	Strap loops
MS35338-44	1/4 Lockwasher	40	Tube-pipe fitting kit, separator, strap loops
MS35338-45	5/16 Lockwasher	21	Support angles, utility grinding machine

2. Location of Equipment--Continued

Table 1. Mounting Hardware--Continued

MS/part no.	Size and description	Qty	Application
MS35338-46	3/8 Lockwasher	18	Storage cabinets, 1.5-kw generator sets, power cable assemblies, special purpose cable assembly, special purpose cable kit, rubber hose assemblies
MS35338-47	7/16 Lockwasher	10	Truck bows
MS35338-48	1/2 Lockwasher	12	Compressor, 3-kw generator set, machinist's vise
MS35492-78	#10 Flat Head Wood Screw x 1.00 L	4	Strap loops
MS35493-102	#14 Round Head Wood Screw x 7/8 L	2	Separator
MS35649-202	#10 (0.190) UNC-2B Nut	52	Strap loops
MS35751-93	3/8-16 UNC-2A Squareneck Bolt x 10.00 L	4	Power cable assemblies, special purpose cable assembly, rubber hose assemblies, special purpose cable kit
MS51861-49	#10 (0.190)-16 Thread Forming Screw x 7/8 L	16	Lampholder junction boxes, duplex junction boxes
MS51861-69	1/4-14 Thread Forming Screw x 7/8 L	4	Switch box
MS51939-3	3-3/16-in. Strap Loop	41	All stowed equipment on floors and storage cabinets
MS51967-2	1/4-20 UNC-2B Hex Nut	4	Tube-pipe fitting kit

2. Location of Equipment--Continued

Table 1. Mounting Hardware--Continued

MS/part no.	Size and description	Qty	Application
MS51967-5	5/16-18 UNC-2B Hex Nut	21	Utility grinding machine, support angles
MS51967-8	3/8-16 UNC-2B Hex Nut	22	Storage cabinets, 1.5-kw generator sets, power cable assemblies, special purpose cable assembly, special purpose cable kit, rubber hose assemblies
MS51967-11	7/16-14 UNC-2B Hex Nut	10	Truck bows
MS51967-14	1/2-13 UNC-2B Hex Nut	12	Compressor, machinist's vise, 3-kw generator set
MS90725-9	1/4-20 UNC-2A Hex Head Capscrew x 1-1/4 L	4	Tube-pipe fitting kit
MS90725-35	5/16-18 UNC-2A Hex Head Capscrew x 1-1/4 L	18	Support angles
MS90725-40	5/16-18 UNC-2A Hex Head Capscrew x 2.00 L	3	Utility grinding machine
MS90725-61	3/8-16 UNC-2A Hex Head Capscrew x 1-1/8 L	6	Storage cabinets
MS90725-68	3/8-16 UNC-2A Hex Head Capscrew x 2-1/2 L	8	1.5-kw generator sets
MS90725-88	7/16 UNC-2A Hex Head Capscrew x 1-3/8 L	10	Truck bows
MS90725-113	1/2-13 UNC-2A Hex Head Capscrew x 1-1/2 L	4	3-kw generator
MS90725-115	1/2-13 UNC-2A Hex Head Capscrew x 2.00 L	4	Compressor
MS90725-118	1/2-13 UNC-2A Hex Head Capscrew x 2-3/4 L	4	Machinist's vise

2. Location of Equipment--Continued

Table 1. Mounting Hardware--Continued

MS/part no.	Size and description	Qty	Application
11021151-1	1 x 1 x 3/16 x 28.00-in. Support Angle	1	12-ton hand hydraulic jacks
11021151-2	1 x 1 x 3/16 x 74.00-in. Support Angle	1	Trestles
7550588-1	72.00-in. Retaining Strap	3	Filler and bleeder, liquid measure, acetylene cylinder, generator test set, tachometer-dwell test set
7550588-2	60.00-in. Retaining Strap	1	Blacksmith's anvil
7550588-3	48.00-in. Retaining Strap	1	Rubber hose assemblies
7550588-4	36.00-in. Retaining Strap	7	Acetylene cylinders, oxygen cylinders
7550588-5	24.00-in. Retaining Strap	11	Hand truck, acetylene cylinder, oxygen cylinder, power cable assemblies, special purpose cable assembly, special purpose cable kit, dispensing pumps, disk sander, extension lights, wheel lift truck
7550588-7	92.00-in. Retaining Strap	7	Spark plug cleaner, tool boxes, mechanic's creeper, impact wrench set
7550588-8	30.00-in. Retaining Strap	1	Eye wash fountain
7550588-10	110.00-in. Retaining Strap	1	Oil bucket pump, grease bucket pump, lubricating unit

2. Location of Equipment--Continued

Table 2. Components to be Mounted

NSN	Qty	Description	Figure no.
5120-00-180-2885	1	ANVIL, BLACKSMITH'S	2
5120-00-224-1372	1	BAR, PINCH	2
7125-00-357-5337	1	CABINET, STORAGE: 18 drawers	2-3
7125-00-330-0130	2	CABINET, STORAGE: 11 drawers	2-3
6150-00-682-3460	2	CABLE ASSEMBLY, POWER, ELECTRICAL: 3 condct, 50 ft	2
2920-01-027-0125	1	CABLE ASSEMBLY, SPECIAL PURPOSE	2
2590-00-148-7961	1	CABLE KIT, SPECIAL PURPOSE	2
7240-00-499-8028	1	CAN, RADIATOR FILLING	9
6130-00-940-7866	1	CHARGER, BATTERY	2
4910-01-064-7313	1	CLEANER AND TESTER, SPARK PLUG	2-3
4310-00-542-4566	1	COMPRESSOR, RECIPROCATING, POWER DRIVEN	2-3
4910-00-251-6981	1	CREEPER, MECHANIC'S	9
5120-00-224-1390	2	CROWBAR	2
8120-00-268-3360	4	CYLINDER, COMPRESSED GAS: acetylene	2-9
8120-00-151-9758	4	CYLINDER, COMPRESSED GAS: oxygen	2-9
4930-00-263-9886	1	DISPENSING PUMP, HAND DRIVEN: gasoline or kerosene	2
4930-00-287-8293	1	DISPENSING PUMP, HAND DRIVEN: Oil, 1-qt	2
4910-00-273-3658	1	FILLER AND BLEEDER, HYDRAULIC SYSTEM	2
4730-00-470-6625	1	FITTING KIT, TUBE-PIPE	2-3
4240-00-551-3134	1	FOUNTAIN, EYE WASH, PORTABLE	9
6115-00-889-1446	2	GENERATOR SET, GASOLINE ENGINE: 1.5-kw, ac, 120/240 V	2-3

2. Location of Equipment--Continued

Table 2. Components to be Mounted--Continued

NSN	Qty	Description	Figure no.
6115-00-017-8239	1	GENERATOR SET, GASOLINE ENGINE: 3-kw, dc, 28 V	2-3
3415-00-517-7754	1	GRINDING MACHINE, UTILITY	2
4720-00-356-8557	5	HOSE ASSEMBLY, RUBBER: 25 ft	2
5120-00-224-7330	4	JACK, HYDRAULIC, HAND: 12 ton	2
5120-00-595-8388	1	JACK KIT, HYDRAULIC, HAND: 10 ton	9
6230-00-268-9436	4	LIGHT, EXTENSION: 20 ft, 2 condct	9
6230-00-729-9259	2	LIGHT, EXTENSION: 25 ft, 3 condct	9
4930-00-720-4849	1	LUBRICATING UNIT, POWER OPERATED	2
7240-00-255-5996	1	MEASURE, LIQUID: 8-qt cap. w/flex spout	2
4930-00-244-4860	1	PUMP, BUCKET, LUBRICATING OIL	2
4930-00-244-4859	1	PUMP, BUCKET, LUBRICATING GREASE	2
5130-00-857-8526	1	SANDER, DISK, ELECTRIC, PORTABLE	2
4940-00-242-4100	1	SEPARATOR, OIL AND WATER, SPRAY GUN	2
4910-00-092-9136	1	TEST SET, GENERATOR	2
4910-00-788-8549	1	TEST SET, TACHOMETER-DWELL	2
5140-00-315-2758	1	TOOL BOX, PORTABLE	2
5140-01-119-2516	1	TOOL BOX, PORTABLE	9
4910-00-262-0392	6	TRESTLE, MOTOR VEHICLE MAINTENANCE	9
3920-01-113-0117	1	TRUCK, HAND, TWO-WHEELED	2
4910-00-554-5983	1	TRUCK, LIFT, WHEEL	9
5120-00-293-1439	1	VISE, MACHINIST'S: 6-in. jaw	2
5120-00-961-9813	1	WRENCH SET, IMPACT HAND	9

2. Location of Equipment--Continued

Table 3. Electrical Components to be Mounted

Part No. or NSN	Qty	Description	Figure no.
5930-00-194-9086	1	SWITCH BOX (ENCLOSED): surface mtd type NDS, class 2 design 2SN box, 120/240 vac, 30 amp (W-S-865)	15-16- 18
5975-00-926-0590	16	BOX CONNECTOR: type I, class 4, style M (W-F-406)	16-18 thru 22
4910-00-800-1405	1	CABLE ASSEMBLY, ELECTRICAL POWER: MIL-C-45820	16
5935-01-022-5623	2	CONNECTOR, CABLE OUTLET: 2-pole, 3-wire, 30 amp, grounding, 125 v, 50/60 Hz (W-C-596/91)	19-22
6145-00-295-0855	30 ft	CORD, FLEXIBLE: type S06CF3/10 RNJ (J-C-580)	15 thru 22
5975-00-440-2703	4	JUNCTION BOX, LAMPHOLDER: type I (W-J-800)	15 thru 18
5975-00-281-0090	4	JUNCTION BOX, DUPLEX: type II (W-J-800)	15 thru 18
5975-00-682-0357	4	COVER, JUNCTION BOX, DUPLEX: type III (W-J-800)	16-17
5935-01-058-9269	4	RECEPTACLE, DUPLEX, GROUNDED: 2-pole, 3-wire (WC-596/40)	16-17
GE-5740-7	4	LAMPHOLDER, GENERAL ELECTRIC	16-17
11021163	1	CABLE ASSEMBLY, POWER consisting of one each of the following: 44-in. flex. cord (J-C-580) connector (W-C-596/92) box connector (W-F-406)	15-17- 18
11021164	1	CABLE ASSEMBLY, POWER consisting of one each of the following: 44-in. flex. cord (J-C-580) plug (W-C-596/91) box connector (W-F-406)	15-17- 18

2. Location of Equipment--Continued

Table 3. Electrical Components to be Mounted--Continued

Part No. or NSN	Qty	Description	Figure no.
11021165	1	CABLE ASSEMBLY, POWER consisting of one each of the following: 37.50-in. flex. cord (J-C-580) plug (W-C-596/91) box connector (W-F-406)	15-16-18
11021166	1	CABLE ASSEMBLY, POWER consisting of one each of the following: 37.50-in. flex. cord (J-C-580) connector (W-C-596-92) box connector (W-F-406)	15-16-18
MS20659-141	28	TERMINAL LUG	18-19
5935-01-113-5623	2	CONNECTOR, PLUG: straight, grounding, 2-pole, 3-wire, 30 amp, 125 v, 50/60 Hz (W-C-596/92)	20-21

3. Installation

NOTE

Hand blind riveter (5120-00-973-0376) is used for installing blind rivet nuts in unit floors and walls. Install blind rivet nuts in accordance with MIL-N-47187.

a. Units 1 and 2. Mark and drill twenty-two 0.25-in. diameter holes and install blind rivet nuts (MS27130-A27) in accordance with figures 7 thru 14.

b. Units 1 and 2. Install strap loops as follows:

(1) Install eleven strap loops (MS51939-3) on truck and trailer walls using twenty-two #10 x 1-in. countersunk head machine screws (MS35190-275) for threading into blind rivet nuts.

(2) Install nine strap loops on truck slats using eighteen #10 x 1-1/4-

in. countersunk head machine screws (MS35190-276), eighteen 7/32-in. flat washers (MS27183-42), eighteen #10 (0.190) lockwashers (MS35338-43), and eighteen #10 (0.190) hex nuts (MS35649-202).

(3) Install twelve strap loops on trailer slats using twenty-four #10 x 1-1/4-in. countersunk head machine screws (MS35190-276), twenty-four 1/4-in. flat washers (MS27183-9), twenty-four 1/4-in. lockwashers (MS35338-44), and twenty-four #10 (0.190) hex nuts (MS35649-202).

(4) Install five strap loops on trailer floor using ten #10 x 1-in. countersunk head machine screws (MS35190-275), ten 1/4-in. lockwashers (MS35338-44), and ten #10 (0.190) hex nuts (MS35649-202).

3. Installation--Continued

c. Unit 1. Follow steps 1 thru 25 below; for equipment installation.

(1) Position compressor (4310-00-542-4566) in truck in accordance with dimensions shown in figures 2 and 3. Mark and drill four 0.50-in. diameter holes in truck floor and secure compressor to floor using four 1/2- x 2-in. hex head capscrews (MS90725-115), four 1/2-in. lockwashers (MS35338-48), and four 1/2-in. hex nuts (MS51967-14).

(2) Position 18-drawer storage cabinet (7125-00-357-5337) in right front corner of truck and butt one 11-drawer storage cabinet (7125-00-330-0130) against it in accordance with figure 2. Remove two bottom rows of drawers from storage cabinets. Mark and drill four 0.37-in. diameter holes through storage cabinet bases and truck floor in accordance with figure 3. Secure storage cabinets to truck floor using four 3/8- x 1-1/8-in. hex head capscrews (MS90725-61), four 3/8-in. flat washers (MS27183-13), four 3/8-in. lockwashers (MS35338-46), and four 3/8-in. hex nuts (MS51967-8).

(3) Position 3-kw generator set (6115-00-017-8239) in truck in accordance with figures 2 and 3. Refer to figure 3 for mounting dimensions. Mark and drill four 0.50-in. diameter holes in truck floor and secure 3-kw generator set to truck floor with four 1/2- x 1-1/2-in. hex head capscrews (MS90725-113), four 1/2-in. lockwashers (MS35338-48), and four 1/2-in. hex nuts (MS51967-14).

NOTE

Battery charger (6130-00-940-7866) is part of the 3-kw generator set and does not require separate installation.

(4) Position the two 1.5-kw generator sets (6115-00-889-1466) in truck in accordance with figures 2 and

3. Refer to figure 3 for mounting dimensions. Mark and drill eight 0.37-in. diameter holes in truck floor. Secure the two 1.5-kw generator sets to truck floor with eight 3/8- x 2-1/2-in. hex head capscrews (MS90725-68), eight 3/8-in. flat washers (MS27183-13), eight 3/8-in. lockwashers (MS35338-46), and eight 3/8-in. hex nuts (MS51967-8).

(5) Position oil bucket pump (4930-00-244-4860), grease bucket pump (4930-00-244-4859), and lubricating unit (4930-00-720-4849) in truck as shown in figure 2. Secure all three components to truck wall with one 110-in. retaining strap (7550588-10).

NOTE

Fabricate the 28-in. support angle as shown in figure 23.

(6) Install 28-in. support angle (11021151-1) on truck floor in accordance with figures 2 and 3. Refer to figure 3 for dimensions. Mark and drill five 0.37-in. diameter holes through 28-in. support angle and truck floor. Secure 28-in. support angle to truck floor with five 5/16- x 1-1/4-in. hex head capscrews (MS90725-35), five 5/16-in. lockwashers (MS35338-45), and five 5/16-in. hex nuts (MS51967-5). Position four 12-ton hand hydraulic jacks (5120-00-244-7330) between 28-in. support angle (11021151-1) and compressor (4310-00-542-4566) in accordance with figure 2.

(7) Position tube-pipe fitting kit (4730-00-470-6625) on truck floor in accordance with figures 2 and 3. Using holes in tube-pipe fitting kit cabinet base as a template, mark and drill four 0.25-in. diameter holes. Secure tube-pipe fitting kit to truck floor with four 1/4- x 1-1/4-in. hex head capscrews (MS90725-9), eight 1/4-in. flat washers (MS27183-9), four 1/4-in. lockwashers (MS35338-44), and four 1/4-in. hex nuts (MS51967-2).

3. Installation--Continued

(8) Position one n-drawer storage cabinet (7125-00-330-0130) on left side of truck in accordance with figure 2. Refer to figure 3 for mounting dimensions. Mark and drill two 0.37-in. diameter holes through 11-drawer storage cabinet base and floor of truck. Secure to truck floor with two 3/8- x 1-1/8-in. hex head capscrews (MS90725-61), two 3/8-in. flat washers (MS27183-13), two 3/8-in. lockwashers (MS35338-46), and two 3/8-in. hex nuts (MS51967-8).

(9) Position hand truck (3920-01-113-0117), including one acetylene cylinder (8120-00-268-3360) and one oxygen cylinder (8120-00-151-9758), in accordance with figure 2. Secure hand truck to truck rack (slats) with two 24-in. retaining straps (7550588-5).

(10) Position blacksmith's anvil (5120-00-180-2885) in accordance with figure 2. Secure blacksmith's anvil to the hand truck with 60-in. retaining strap (7550588-2).

(11) Position filler and bleeder (4910-00-273-3658), liquid measure (7240-00-255-5996), and one acetylene cylinder (8120-00-268-3360) in accordance with figure 2. Secure all three components to truck wall with two 72-in. retaining straps (7550588-1).

(12) Mark and drill four 0.37-in. diameter holes in truck slats in accordance with figure 7. Install four 3/8- x 10-in. squareneck bolts (MS35751-93), eight 13/32-in. flat washers (MS27183-14), four 3/8-in. lockwashers (MS35338-46), and eight 3/8-in. hex nuts (MS51967-8).

(13) Hang two electrical power cable assemblies (6150-00-682-3460), special purpose cable assembly (2920-01-027-0125), and special purpose cable kit (2590-00-148-7961) on squareneck bolts (MS35751-93) in accordance with

figure 2 and secure with two 24-in. retaining straps (7550588-5).

(14) Hang five rubber hose assemblies (4720-00-356-8557) on squareneck bolt (MS35751-93) in accordance with figure 2 and secure with 48-in. retaining strap (7550588-3).

(15) Stow pinch bar (5120-00-224-1372) and two crowbars (5120-00-224-1390) between compressor legs in accordance with figure 2.

(16) Secure dispensing pumps (4930-00-287-8293 and 4930-00-263-9886) to top slat, right rear of truck, using two 24-in. retaining straps (7550588-5) in accordance with figure 4.

(17) Mark and drill four 0.25-in. diameter holes in top of 18-drawer storage cabinet in accordance with dimensions shown in figure 3. Secure two strap loops (MS51939-3) to 18-drawer storage cabinet top using four #10 x 1-in. flat head wood screws (MS35492-78).

(18) Position spark plug cleaner (4910-01-064-7313) on top of 18-drawer storage cabinet as shown in figure 2. Secure spark plug cleaner to 18-drawer storage cabinet with 92-in. retaining strap (7550588-7).

(19) Mark and drill four 0.25-in. diameter holes in front of 18-drawer storage cabinet in accordance with dimensions shown in figure 4. Secure two strap loops (MS51939-3) to 18-drawer storage cabinet using four 3/16- x 13/32-in. blind rivets (MS20601-MP6W4).

(20) Position tool box (5140-00-315-2758) as shown in figure 2 and secure tool box to 18-drawer storage cabinet with 92-in. retaining strap (7550588-7).

3. Installation-Continued

(21) Secure disk sander (5130-00-857-8526) to top slat of truck rack using 24-in. retaining strap (7550588-5) in accordance with figure 2.

(22) Position utility grinding machine (3415-00-517-7754) on top of 11-drawer storage cabinet in accordance with dimensions shown in figure 2. Using utility grinding machine base as a template, mark and drill three 0.37-in. diameter holes through n-drawer storage cabinet top. Secure utility grinding machine with three 5/16- x 2.00-in. hex head capscrews (MS90725-40), three 5/16-in. flat washers (MS27183-11), three 5/16-in. lockwashers (MS35338-45), and three 5/16-in. hex nuts (MS51967-5).

(23) Position machinist's vise (5120-00-293-1439) on 11-drawer storage cabinet top in accordance with dimensions in figure 2. Using machinist's vise base as a template, mark and drill four 0.50-in. diameter holes through 11-drawer storage cabinet top. Secure machinist's vise to 11-drawer storage cabinet top with four 1/2- x 2-3/4-in. hex head Capscrews (MS90725-118), four 1/2-in. flat washers (MS27183-17), four 1/2-in. lockwashers (MS35338-48), and four 1/2-inch hex nuts (MS51967-14).

(24) Position generator test set (4910-00-092-9136) and tachometer-dwell test set (4910-00-788-8549) on top of tube-pipe fitting kit in accordance with figure 2. Secure test sets to truck wall with 72-in. retaining strap (7550588-1).

(25) Position separator (4940-00-242-4100) centered on top slat of truck rack in accordance with dimension in figure 2. Using separator base as a template, drill two 0.12-in. diameter pilot holes in slat. Secure separator bracket to slat with two #14 x 7/8-in. round head wood screws (MS35493-102), and two 1/4-in. lockwashers (MS35338-44).

d. Unit 2. Follow steps 1 thru 12 below for equipment installation.

NOTE

Fabricate the 74-in. support angle as shown in figure 23.

(1) Position 74-in. support angle (11021151-2) on trailer floor in accordance with figure 9. Refer to figure 10 for dimensions. Mark and drill thirteen 0.31-in. diameter holes through 74-in. support angle and trailer floor. Secure 74-in. support angle to trailer floor with thirteen 5/16- x 1-1/4-in. hex head capscrews (MS90725-35), thirteen 5/16-in. lockwashers (MS35338-45), and thirteen 5/16-in. hex nuts (MS51967-5).

(2) Stow the six motor vehicle trestles (4910-00-262-0392) between 74-in. support angle and front wall of trailer, as shown in figure 9.

(3) Position hydraulic jack kit (5120-00-595-8388) against 74-in. support angle (11021151-2) and 18 inches from left side of trailer. Refer to figure 9 for dimensions and location.

(4) Position three oxygen cylinders (8120-00-151-9758) in trailer as shown in figure 9. Refer to figure 12 for mounting dimensions. Secure oxygen cylinders to trailer wall and rack with six 36-in. retaining straps (7550588-4) in accordance with figure 11.

(5) Position mechanic's creeper (4910-00-251-6981) on top of trailer right side wheel well as shown in figure 11 and secure to trailer wall with two 92-in. retaining straps (7550588-7).

(6) Position tool box (5140-01-119-2516) on top of trailer left side wheel well as shown in figure 13 and secure to trailer wall and floor with two 92-in. retaining straps (7550588-7).

3. Installation--Continued

(7) Position four 20-ft extension lights (6230-00-268-9436) and two 25-ft extension lights (6230-00-729-9259) on trailer rack in accordance with figure 9. Secure to top slat on trailer rack with two 24-in. retaining straps (7550588-5).

(8) Position case of impact wrench set (5120-00-961-9813) on trailer floor in accordance with figure 9. Secure to trailer floor and wall with 92-in. retaining strap (7550588-7).

(9) Position wheel lift truck (4910-00-554-5983) in trailer as shown in figure 9. Move wheel lift truck forward against the box for hydraulic jack kit (5120-00-595-8388) and secure with two 24-in. retaining straps (7550588-5).

(10) Position two acetylene cylinders (8120-00-268-3360) in trailer as shown in figure 9. Secure to trailer wall with 36-in. retaining strap (7550588-4).

(11) Position eye wash fountain (4240-00-551-3134) in trailer as shown in figure 9. Secure to trailer wall with 30-in. retaining strap (7550588-8).

(12) Position radiator filling can (7240-00-499-8028) in trailer as shown in figure 9 between trailer wall and motor vehicle trestles.

e. Unit 1. Follow steps 1 thru 13 below; for electrical component installation.

(1) To provide sufficient head room for personnel to work in the M35A2 cargo truck, raise the bows 18 inches and drill ten 0.43-in. diameter holes through bow sockets and bows. Secure bows in place with ten 7/16 x 1-3/8-in.

hex head capscrews (MS90725-88), ten 7/16-in. lockwashers (MS35338-47), and ten 7/16-in. hex nuts (MS51967-11).

(2) Position switch box (5930-00-194-9086) on the two top slats of truck body in accordance with figure 16. Using hole of switch box as a template, mark and drill four 0.12-in. diameter pilot holes. Secure switch box to truck racks with four 1/4- x 7/8-in. thread forming screws (MS51861-69).

(3) Install electrical power cable assembly (4910-00-800-1405) through box connector in bottom of switch box and connect to circuit breaker inside switch box.

(4) Position four lampholder junction boxes (5975-00-440-2703) on inner side of second and fourth bows as shown in figure 15. Mark and drill eight 0.12-in. diameter holes and secure lampholder junction boxes to bows with eight #10 (0.190) x 7/8-in. thread forming screws (MS51861-49).

(5) Position four duplex junction boxes (5975-00-281-0090) on bows as shown in figures 16 and 17. Mark and drill eight 0.12-in. diameter holes and secure duplex junction boxes to bows with eight #10 (0.190) x 7/8-in. thread forming screws (MS51861-49).

(6) Remove two knockout slugs from each lampholder junction box (5975-00-440-2703) and each duplex junction box (5975-00-281-0090) in line with bows. Install sixteen strain relief box connectors (5975-00-926-0590) in the junction boxes and install jam nuts on strain relief box connectors.

(7) Make up four power cable assemblies (11021163, 11021164, 11021165, 11021166) in accordance with figures 19 thru 22 and install in accordance with figures 16, 17, and 18.

3. Installation--Continued

(8) Install a 14-foot length of flexible cord (6145-00-295-0855) through duplex junction boxes and lampholder junction boxes on second and third bows. Refer to figure 18. Strip a 3-inch length of outside insulation from flexible cord on inside of each junction box. Strip 1 inch of insulation from each individual wire and twist wire to fit terminal lug (MS20659-141). Install and crimp terminal lug in place.

(9) Connect three wires to lampholder (GE-5740-7) and secure to lampholder junction box. Repeat this step for remaining three lampholder junction boxes. Refer to figures 16 and 17.

(10) Install four duplex receptacles 5935-01-058-9265) by stripping 3 inches of outside insulation from flexible cord. Strip 1 inch of in-

ulation from each individual wire and twist wire to fit terminal lug (MS20659-141). Install terminal lug and crimp. Connect wires to duplex receptacles and secure duplex receptacles to duplex junction boxes with screws provided with duplex receptacles.

(11) Install four duplex junction box covers (5975-00-682-0357) to duplex junction boxes and secure with screws provided in covers. Refer to figure 16.

(12) Tighten all strain relief box connectors to secure flexible cords in junction boxes and switch box. Refer to figure 16.

(13) Secure power cable assemblies to bows and truck rack with twenty-eight 12.00-in. tiedown straps (MS3367-3) in accordance with figures 15, 16, and 17.

RIGHT CURBSIDE

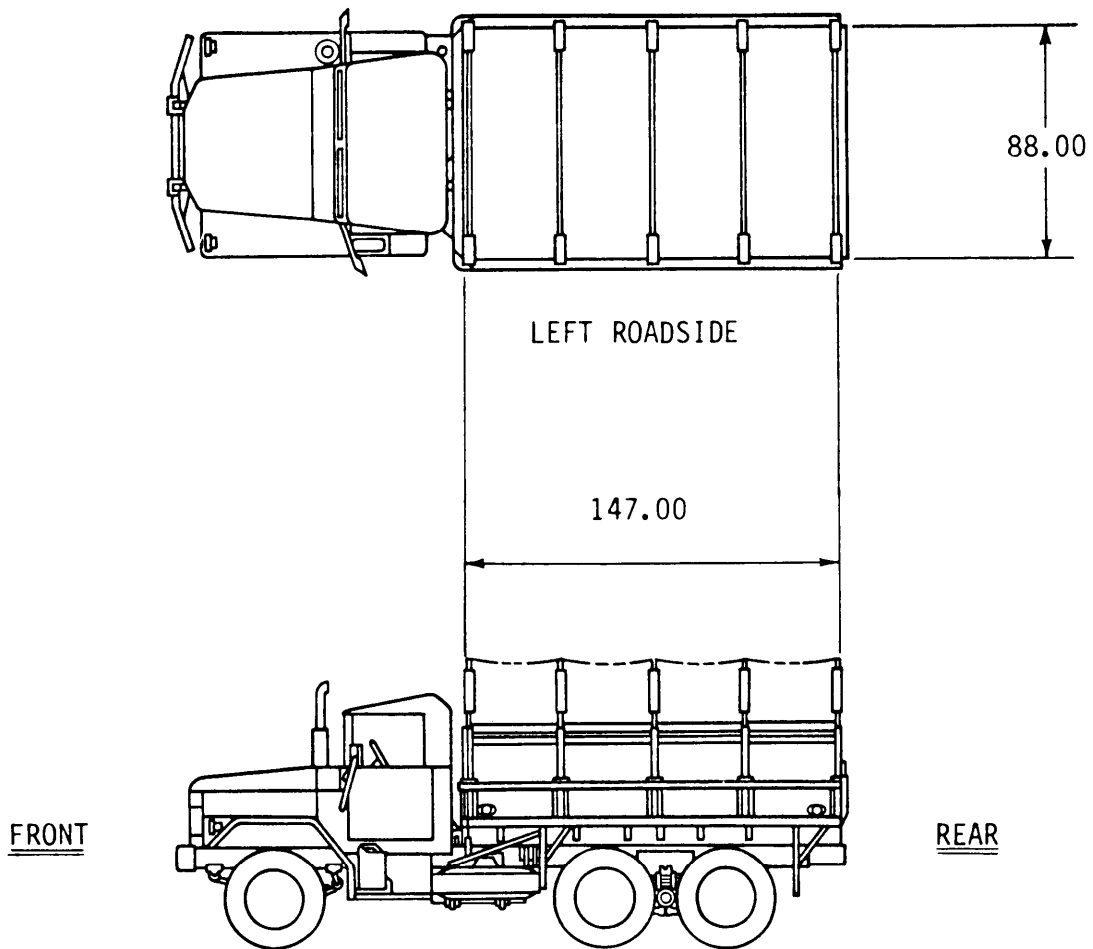

LEFT ROADSIDE

88.00

147.00

FRONT

REAR

Figure 1. Cargo Truck, M35A2, Unit 1.

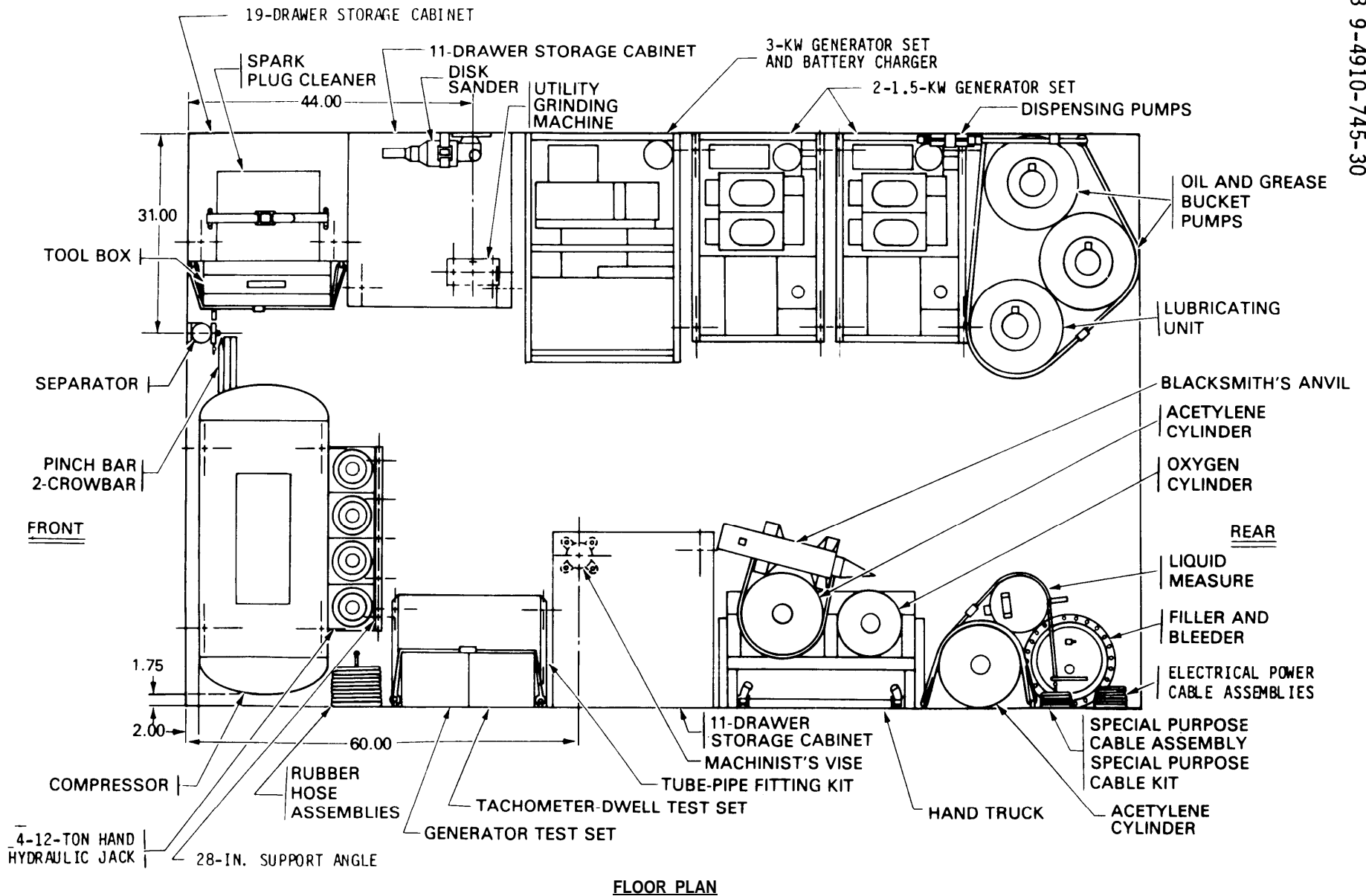

Figure 2. Components to be Mounted, Unit 1, M35A2.

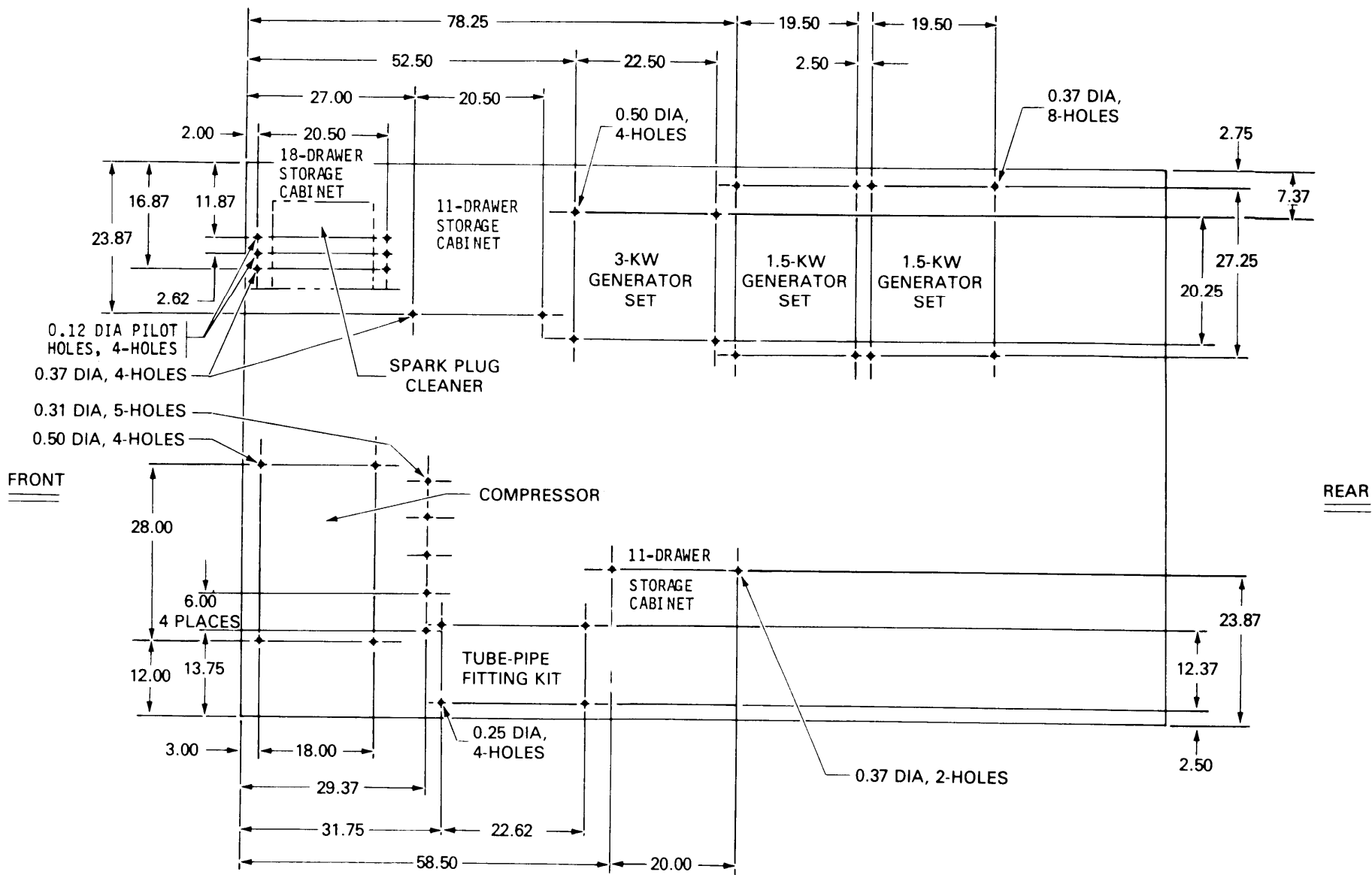

Figure 3. Hole Dimensions for Mounting Components, Unit 1, M35A2, Floor Plan.

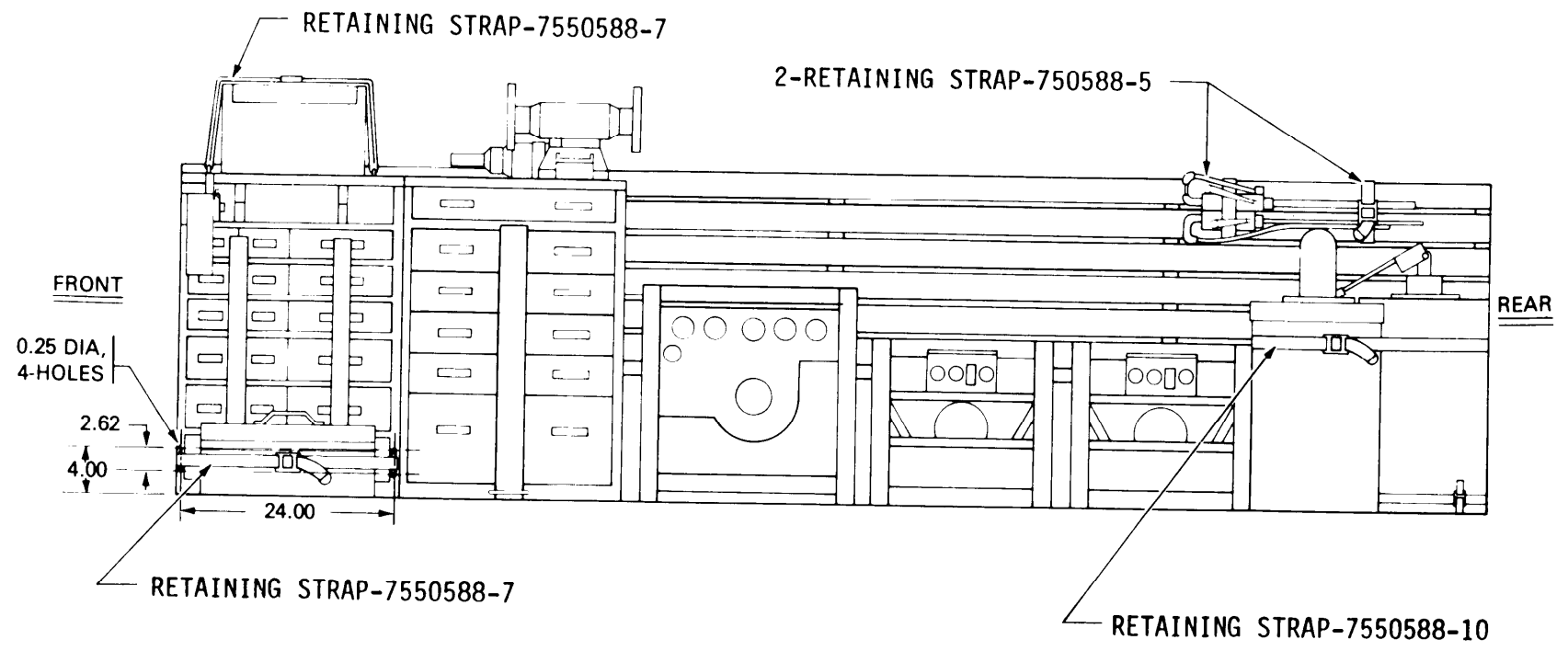

Figure 4. Hole Dimensions for Blind Rivet Nuts, Unit 1, M35A2, Right Side Elevation.

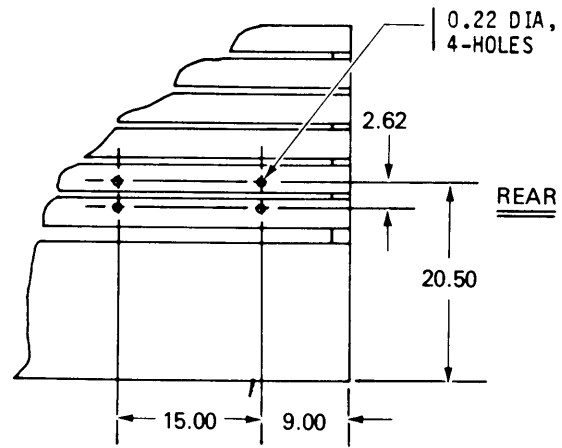

Figure 5. Hole Dimensions for Strap Loops, Unit 1, M35A2, Right Side Elevation.

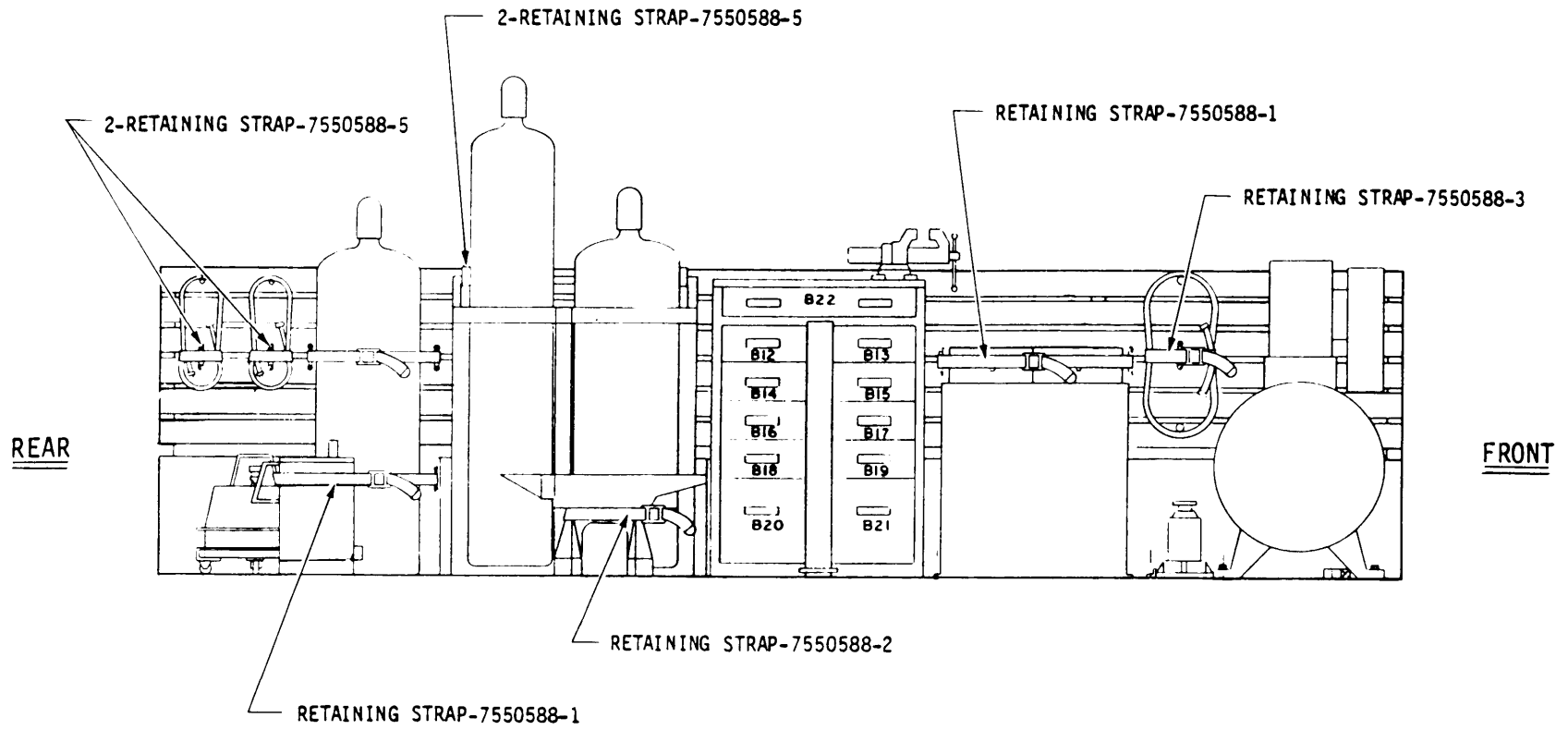

Figure 6. Components to be Mounted, Unit 1, M35A2, Left Side Elevation.

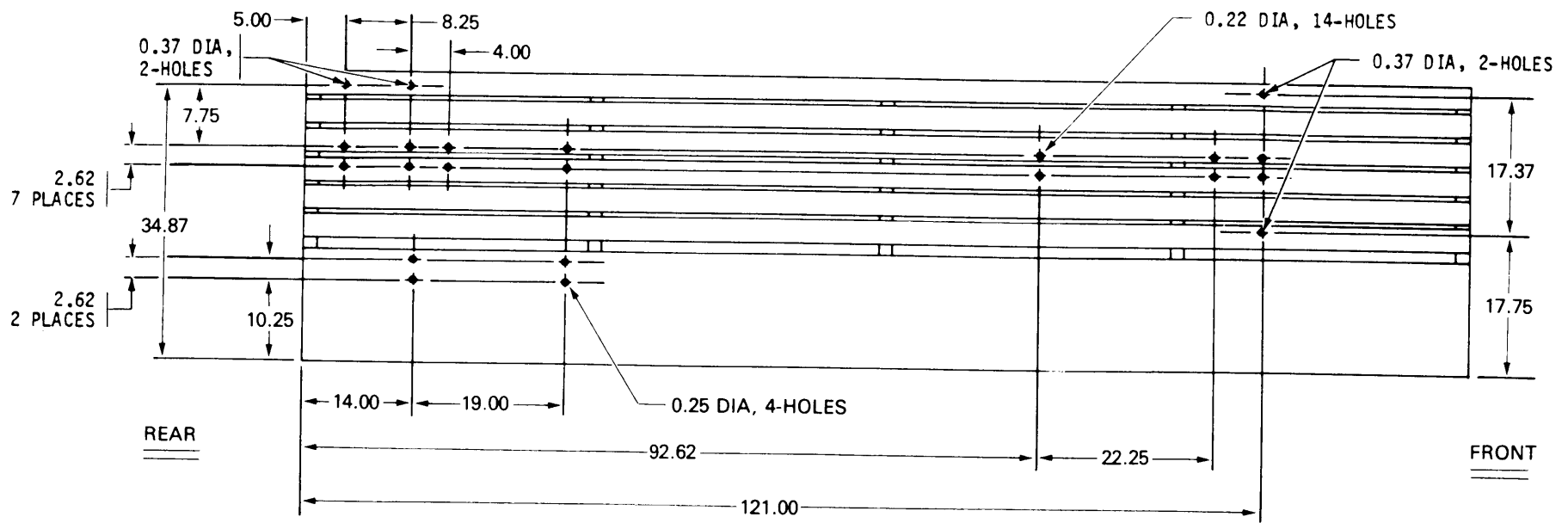

Figure 7. Hole Dimensions for Blind Rivet Nuts and Strap Loops, Unit 1, M35A2, Left Side Elevation.

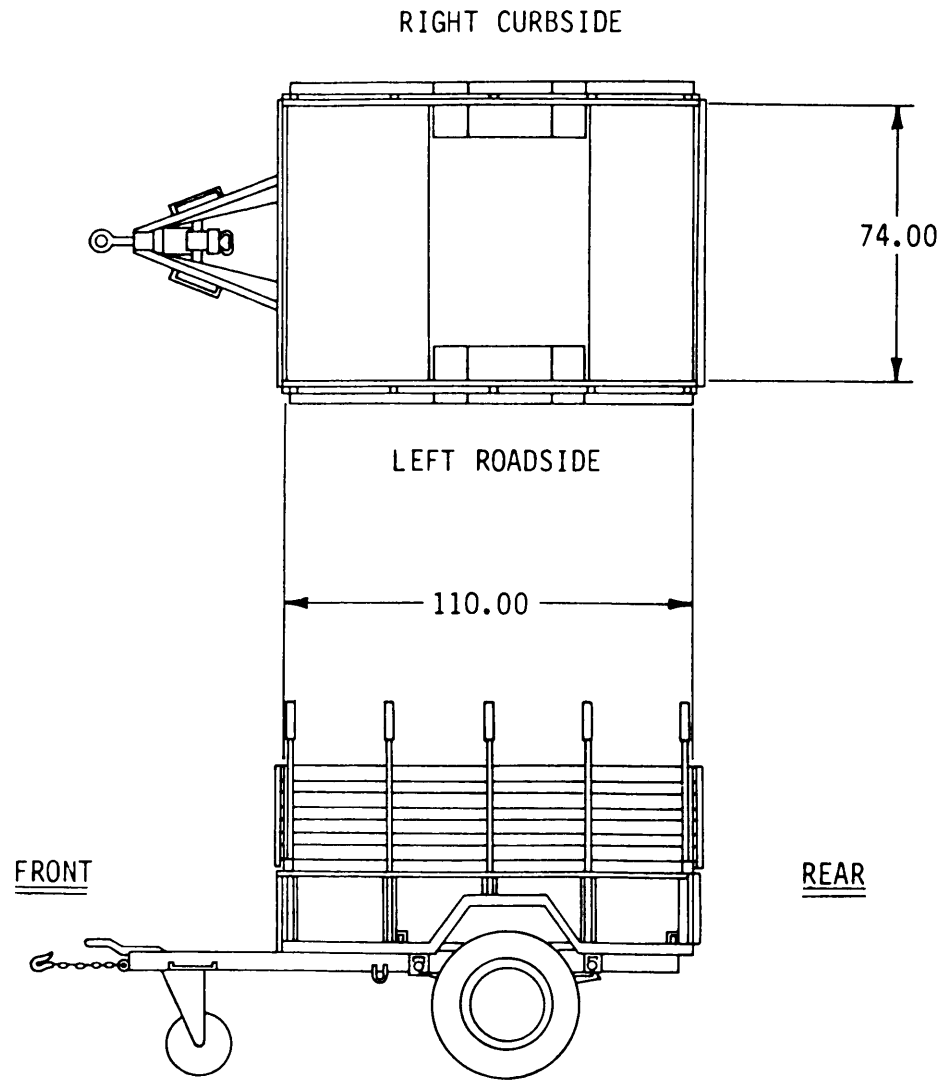

Figure 8. Cargo Trailer, M105A2, Unit 2.

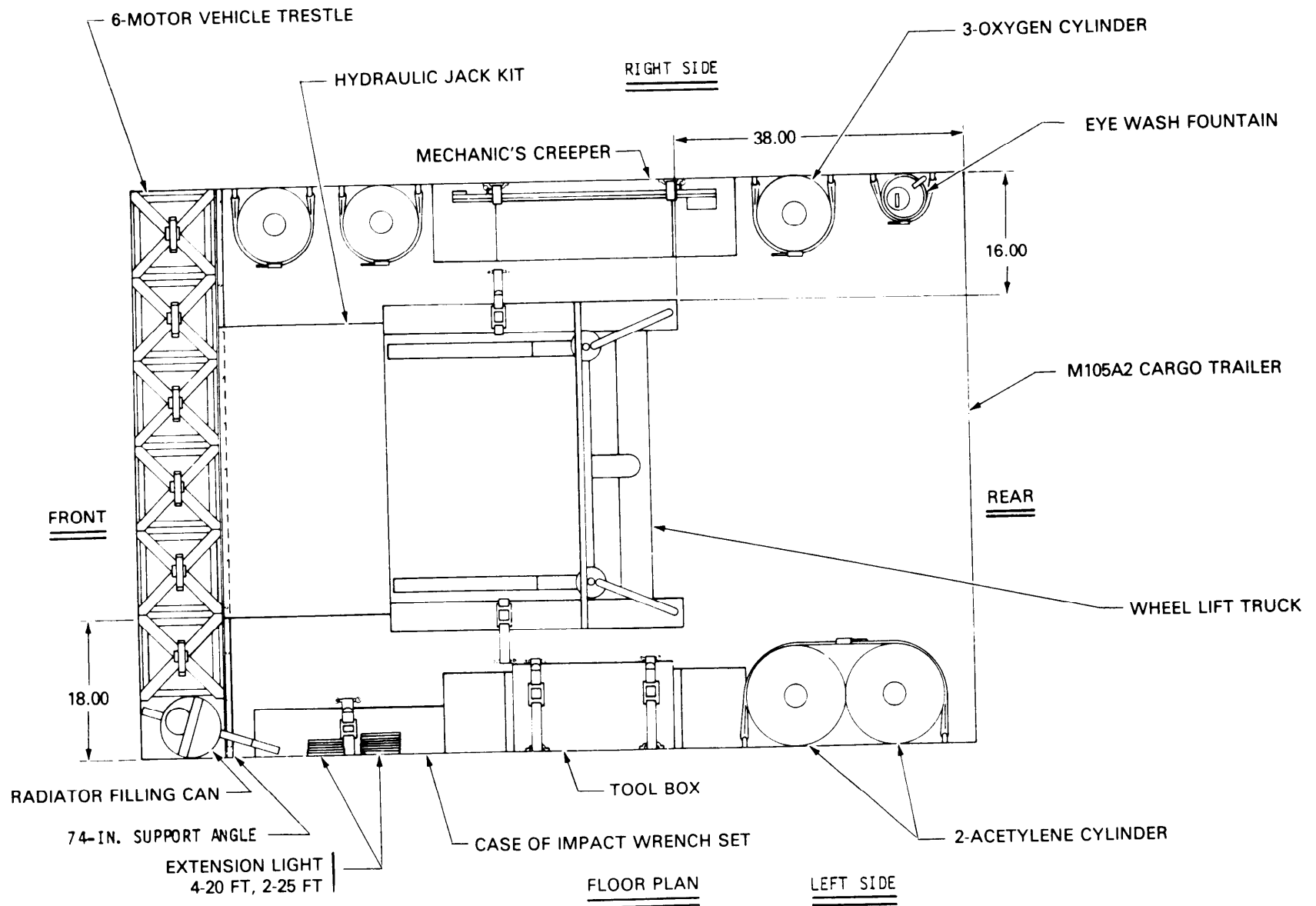

Figure 9. Components to be Mounted, Unit 2, M105A2.

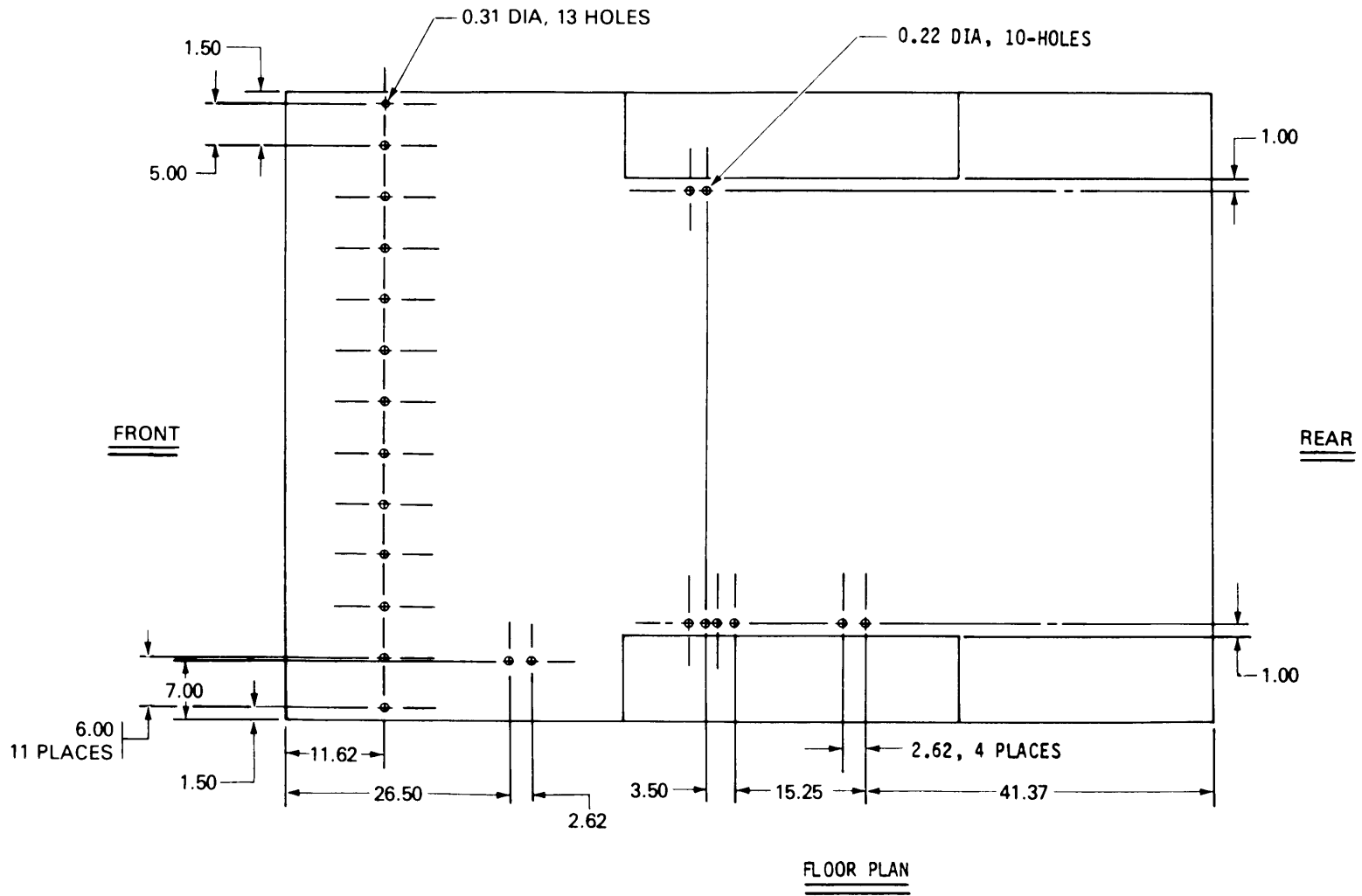

Figure 10. Hole Dimensions for 74-in. Support Angle and Strap Loops, Unit 2, M105A2, Floor Plan.

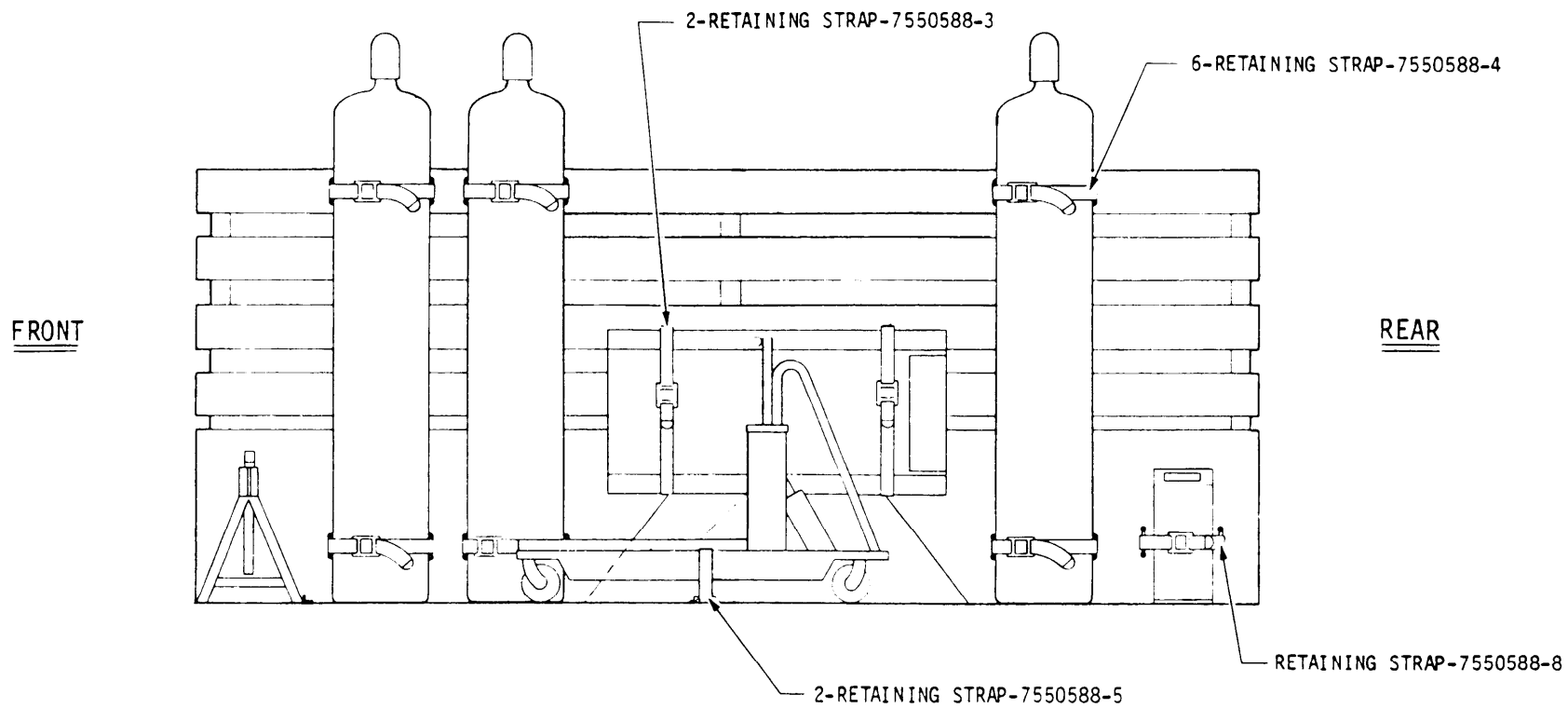

Figure 11. Components to be Mounted, Unit 2, M105A2, Right Side Elevation.

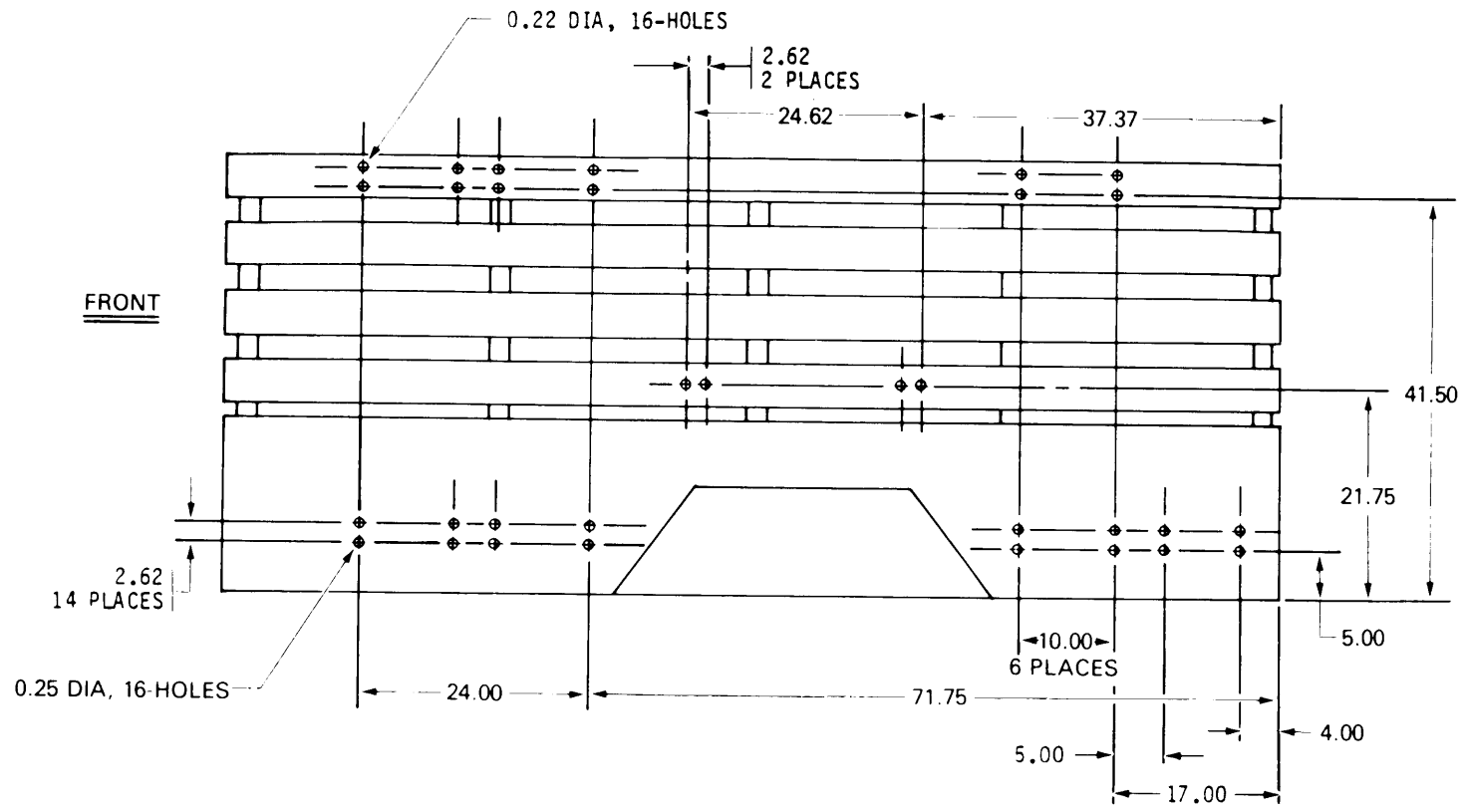

Figure 12. Hole Dimensions for Blind Rivet Nuts and Strap Loops, Unit 2, M105A2, Right Side Elevation.

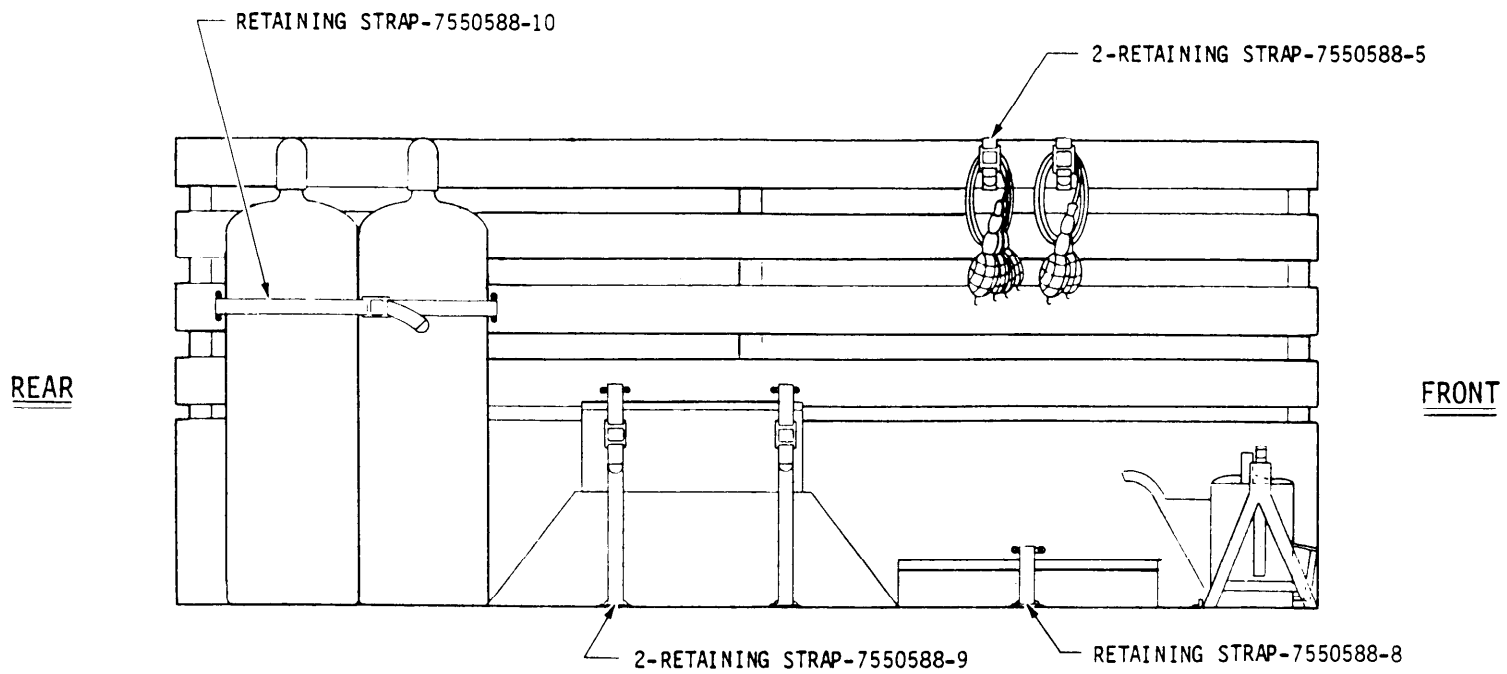

Figure 13. Components to be Mounted, Unit 2, M105A2, Left Side Elevation.

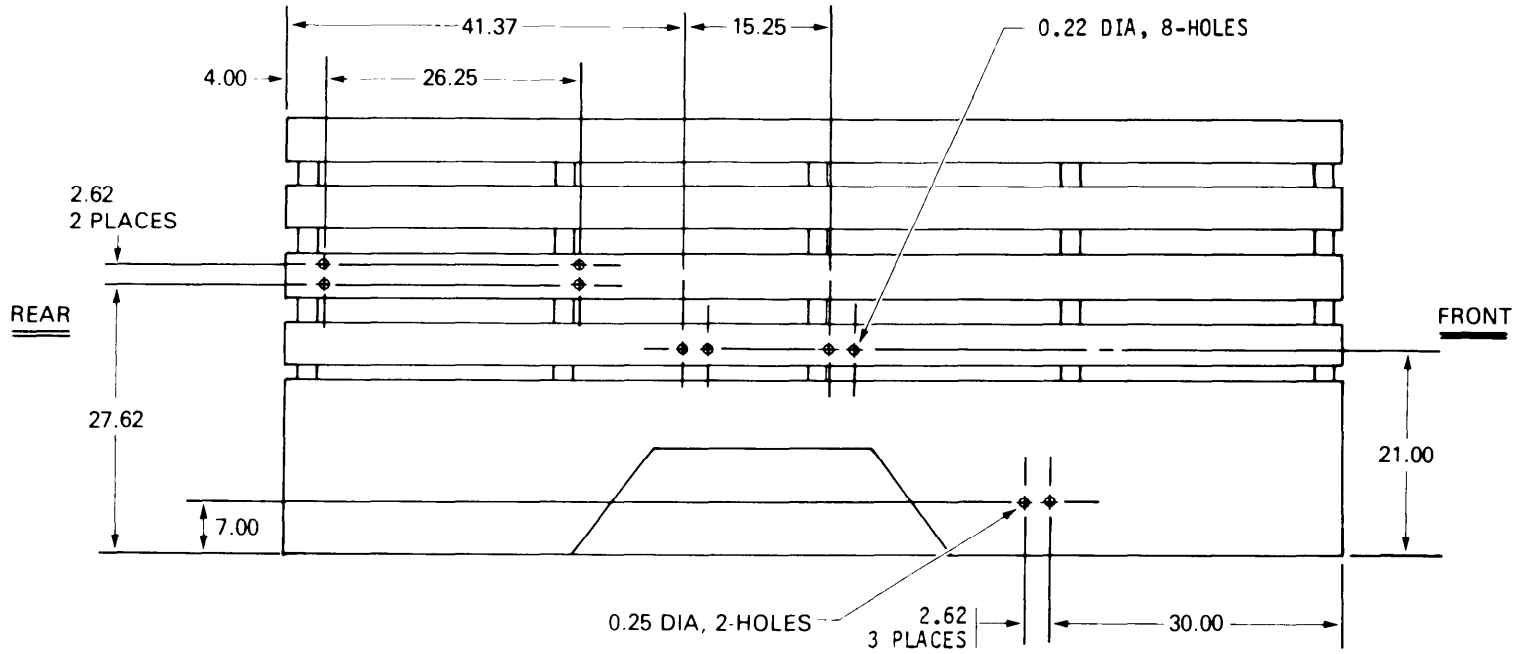

Figure 14. Hole Dimensions for Blind Rivet Nuts and Strap Loops, Unit 2, M105A2, Left Side Elevation.

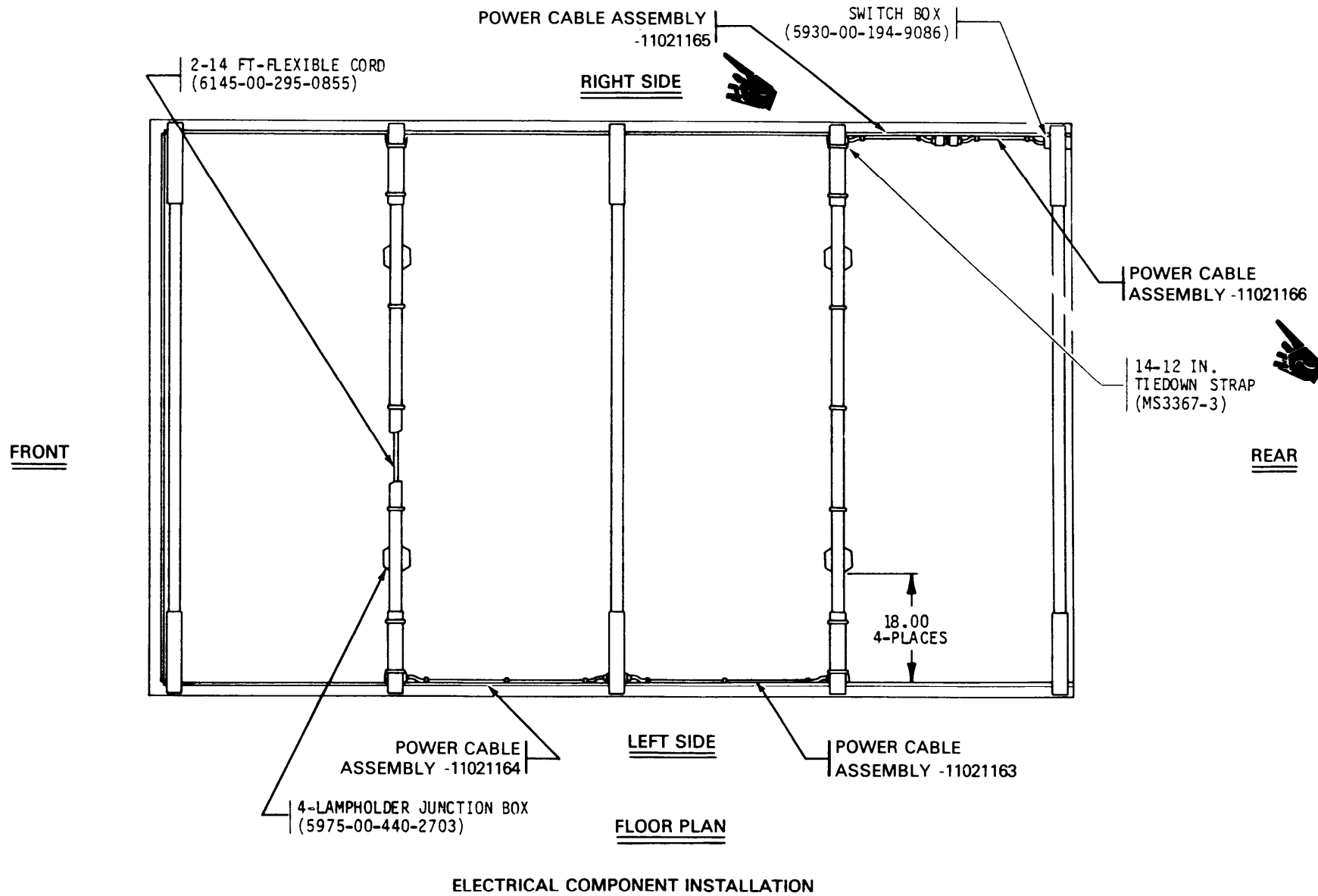

Figure 15. Electrical Components to be Mounted, Unit 1, M35A2, Floor Plan.

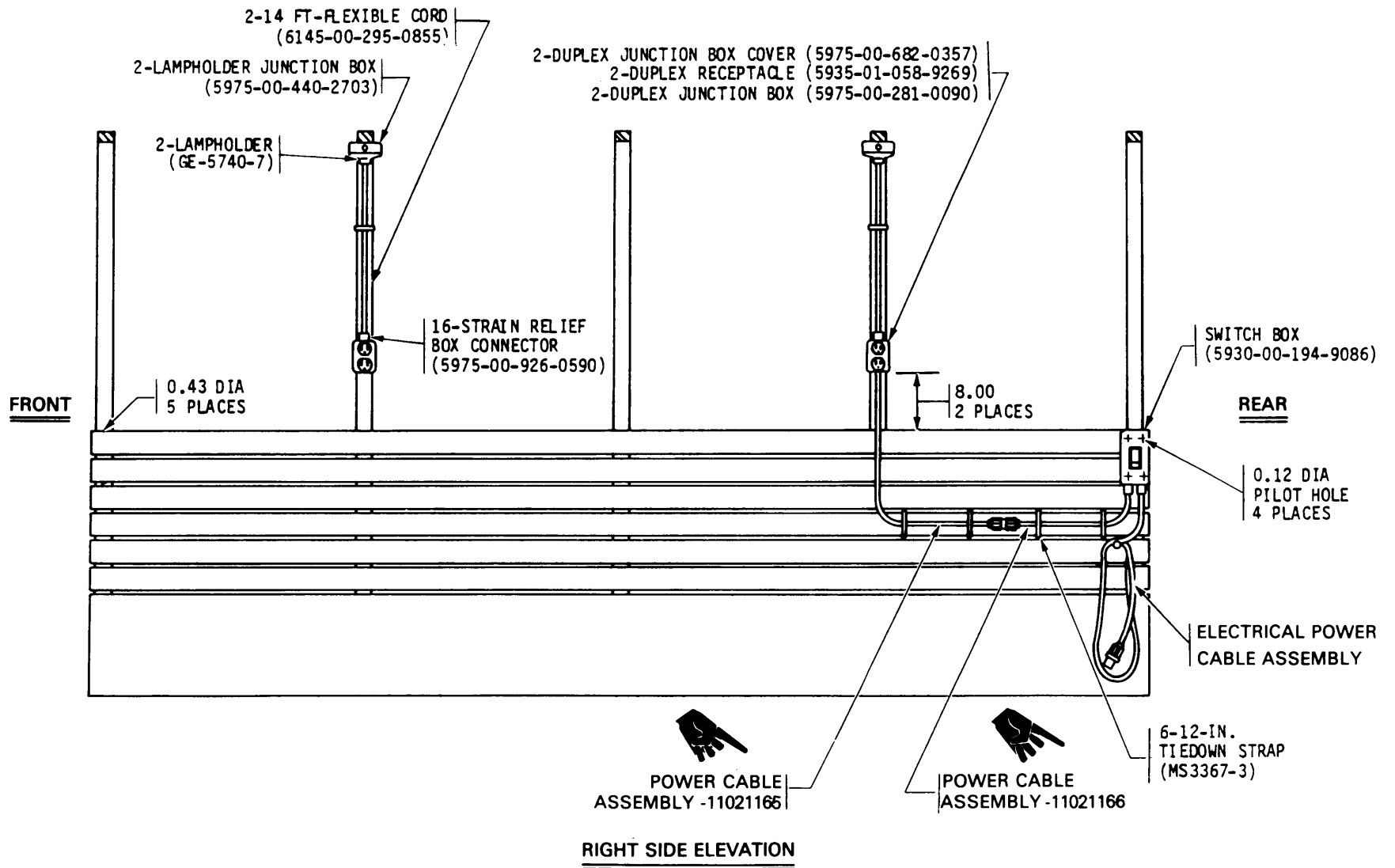

Figure 16. Electrical Components to be Mounted, Unit 1, M35A2, Right Side Elevation.

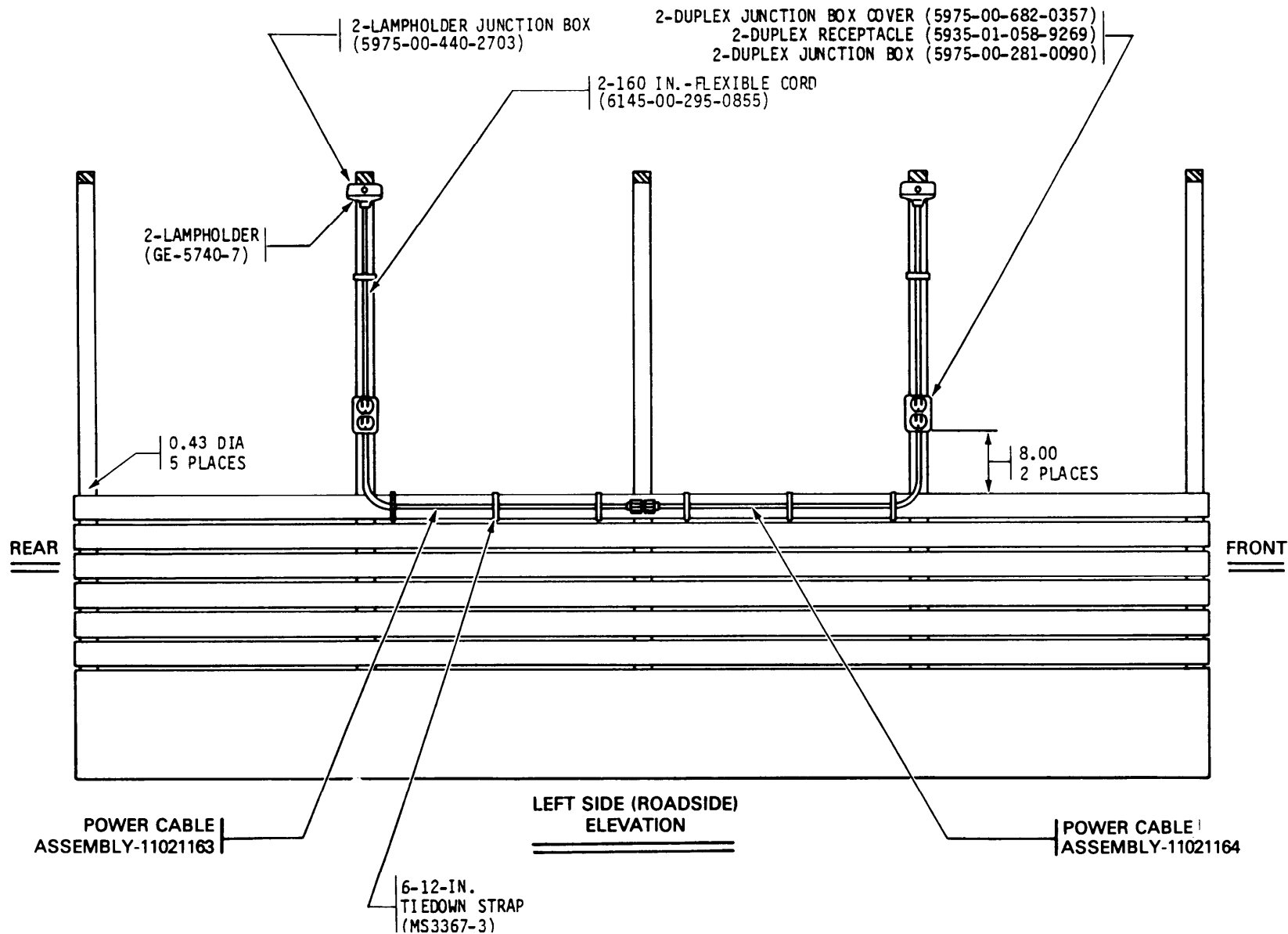

Figure 17. Electrical Components to be Mounted, Unit 1, M35A2, Left Side Elevation.

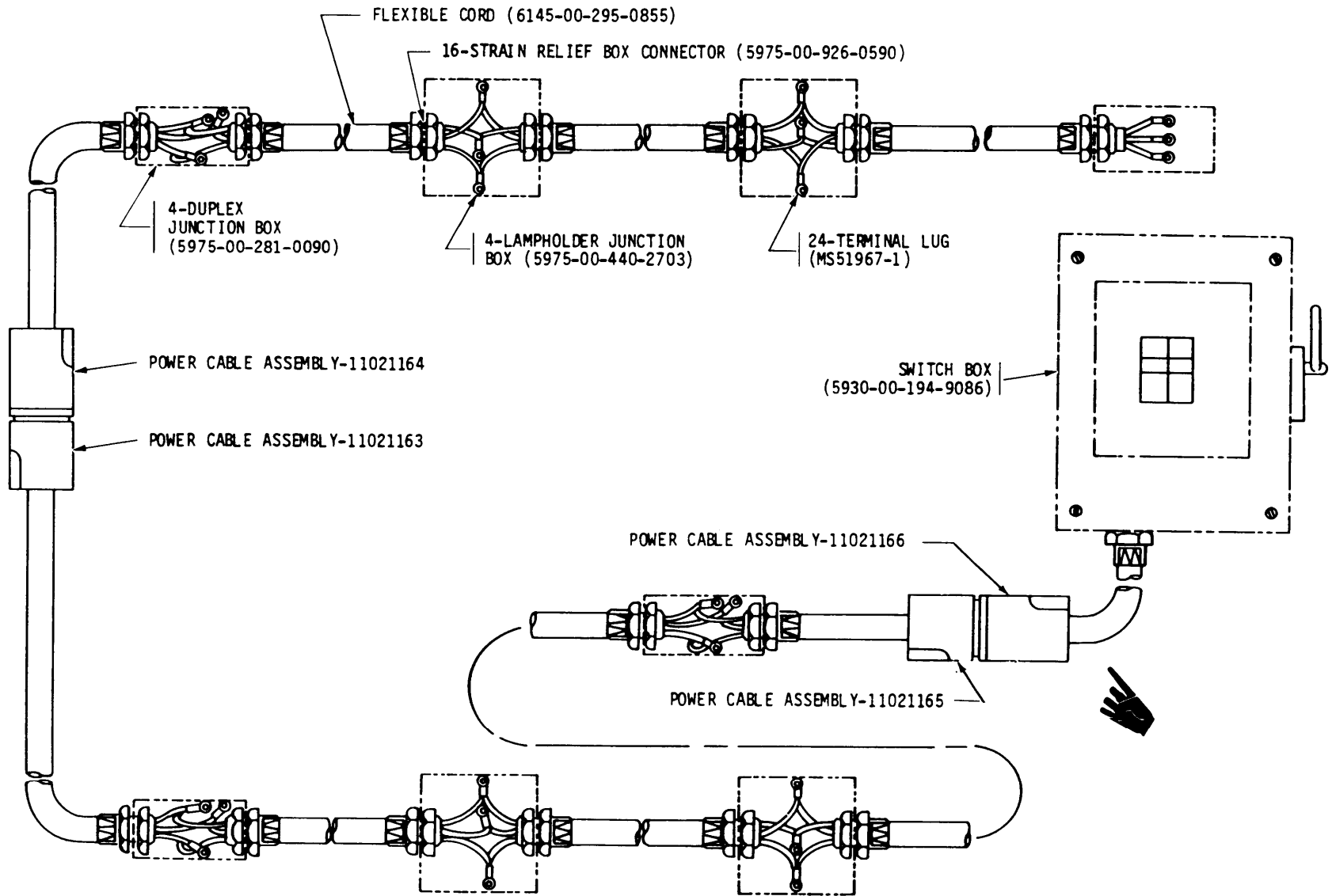
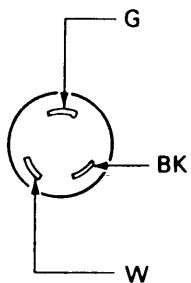

Figure 18. Electrical Schematic, Unit 1, M35A2.



WIRING DIAGRAM

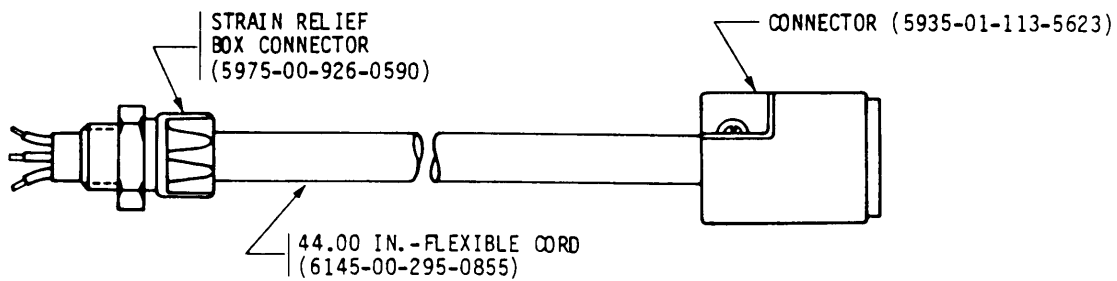

Figure 19. Power Cable Assembly, 11021163, Unit 1, M35A2.

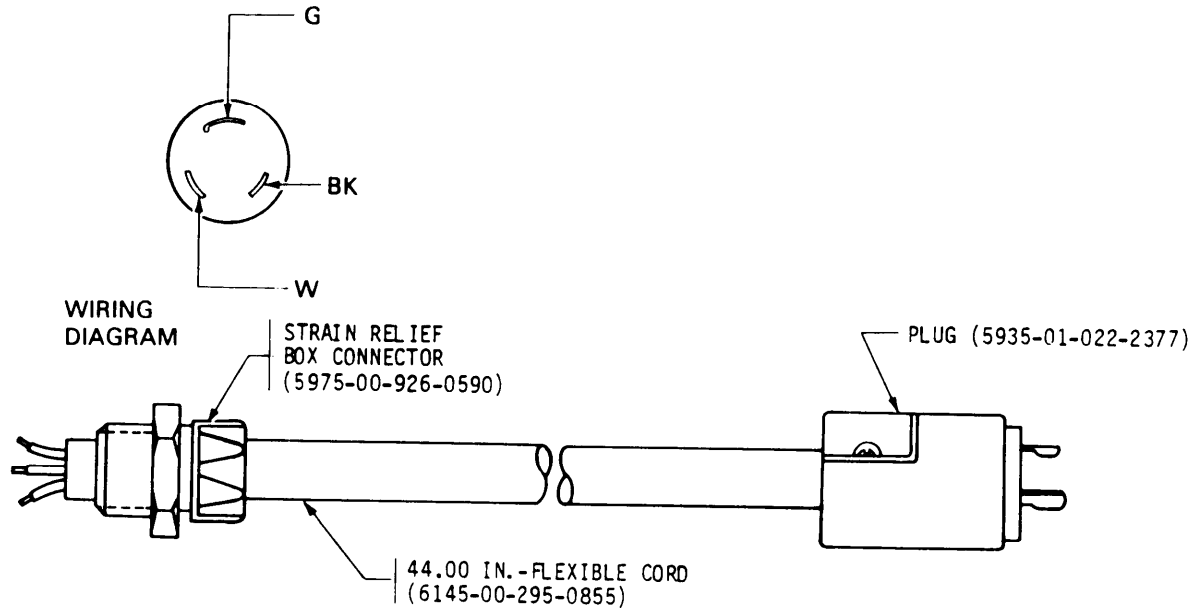

Figure 20. Power Cable Assembly, 11021164, Unit 1, M35A2.

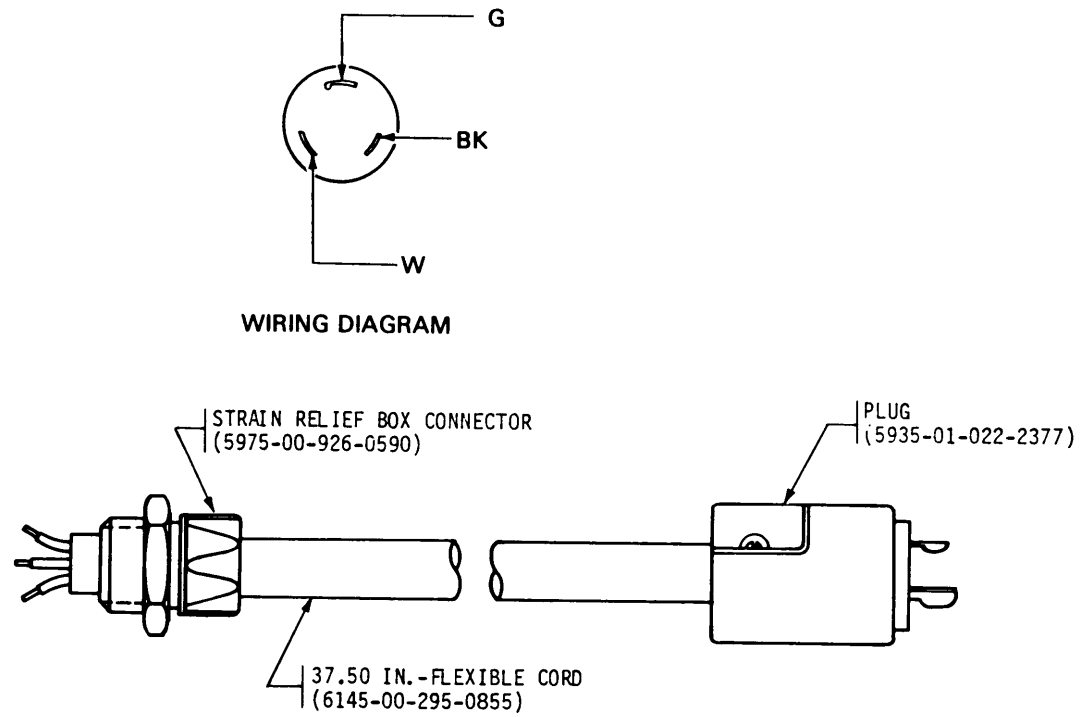

Figure 21. Power Cable Assembly, 11021165, Unit 1, M35A2.

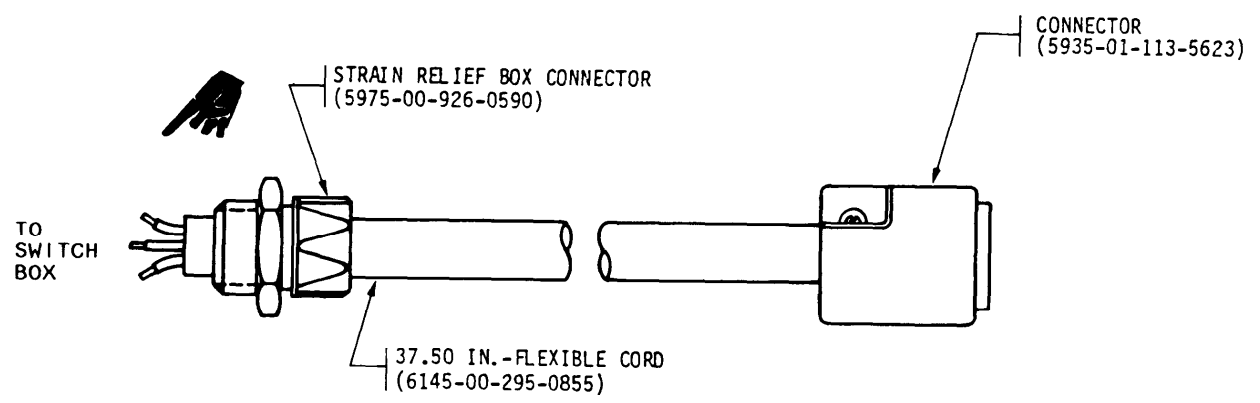
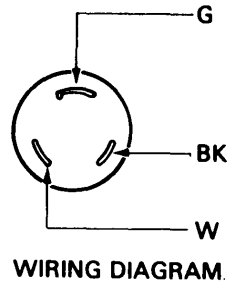
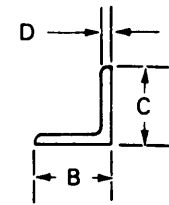
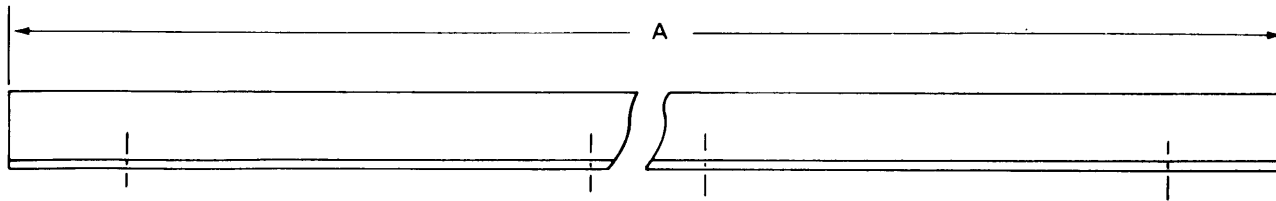

Figure 22. Power Cable Assembly, 11021166, Unit 1, M35A2.

U.S. GOVERNMENT PRINTING OFFICE: 1988 542-043/80033



PART NO.	DIM A	DIM B	DIM C	DIM D	HOLE SIZE	HOLE PATTERN
11021151-1	28.00	1.00	1.00	0.187	0.31	REFER TO FIG. 3
11021151-2	74.00	1.00	1.00	0.187	0.31	REFER TO FIG. 10

Figure 23. Support Angles, Units 1 and 2, M35A2 and M105A2.

Table 4. Drill Diameter Conversion Chart

Nominal size	Decimal size	Nominal size	Decimal size
	Inch		Inch
1/16	0.062	19/64	0.296
5/64	0.078	5/16	0.312
3/32	0.093	21/64	0.328
7/64	0.104	11/32	0.343
1/8	0.125	23/64	0.359
9/64	0.140	3/8	0.375
5/32	0.156	25/64	0.390
11/64	0.171	13/32	0.406
3/16	0.187	27/64	0.421
13/64	0.203	7/16	0.437
7/32	0.218	29/64	0.453
15/64	0.234	15/32	0.468
1/4	0.250	31/64	0.484
17/64	0.265	1/2	0.500
9/32	0.291		

By Order of the Secretary of the Army:

Official:

JOHN A. WICKHAM, JR.
General, United States Army
Chief of Staff

ROBERT M. JOYCE
Major General, United States Army
The Adjutant General

Distribution:

To be distributed in accordance with DA Form 12-34C requirements
for Shop Equipment and Maintenance Repair.

RECOMMENDED CHANGES TO EQUIPMENT TECHNICAL PUBLICATIONS



THEN...JOT DOWN THE
DOPE ABOUT IT ON THIS FORM.
CAREFULLY TEAR IT OUT, FOLD IT
AND DROP IT IN THE MAIL.

SOMETHING WRONG WITH PUBLICATION

FROM: (PRINT YOUR UNIT'S COMPLETE ADDRESS)

DATE SENT

PUBLICATION NUMBER

PUBLICATION DATE

PUBLICATION TITLE

BE EXACT PIN-POINT WHERE IT IS

PAGE
NO.

PARA-
GRAPH

FIGURE
NO.

TABLE
NO.

IN THIS SPACE, TELL WHAT IS WRONG
AND WHAT SHOULD BE DONE ABOUT IT.

TEAR ALONG PERFORATED LINE

PRINTED NAME, GRADE OR TITLE AND TELEPHONE NUMBER

SIGN HERE

The Metric System and Equivalents

Linear Measure

1 centimeter = 10 millimeters = .39 inch
 1 decimeter = 10 centimeters = 3.94 inches
 1 meter = 10 decimeters = 39.37 inches
 1 dekameter = 10 meters = 32.8 feet
 1 hectometer = 10 dekameters = 328.08 feet
 1 kilometer = 10 hectometers = 3,280.8 feet

Weights

1 centigram = 10 milligrams = .15 grain
 1 decigram = 10 centigrams = 1.54 grains
 1 gram = 10 decigrams = .035 ounce
 1 dekagram = 10 grams = .35 ounce
 1 hectogram = 10 dekagrams = 3.52 ounces
 1 kilogram = 10 hectograms = 2.2 pounds
 1 quintal = 100 kilograms = 220.46 pounds
 1 metric ton = 10 quintals = 1.1 short tons

Liquid Measure

1 centiliter = 10 milliliters = .34 fl. ounce
 1 deciliter = 10 centiliters = 3.38 fl. ounces
 1 liter = 10 deciliters = 33.81 fl. ounces
 1 dekaliter = 10 liters = 2.64 gallons
 1 hectoliter = 10 dekaliters = 26.42 gallons
 1 kiloliter = 10 hectoliters = 264.18 gallons

Square Measure

1 sq. centimeter = 100 sq. millimeters = .155 sq. inch
 1 sq. decimeter = 100 sq. centimeters = 15.5 sq. inches
 1 sq. meter (centare) = 100 sq. decimeters = 10.76 sq. feet
 1 sq. dekameter (are) = 100 sq. meters = 1,076.4 sq. feet
 1 sq. hectometer (hectare) = 100 sq. dekameters = 2.47 acres
 1 sq. kilometer = 100 sq. hectometers = .386 sq. mile

Cubic Measure

1 cu. centimeter = 1000 cu. millimeters = .06 cu. inch
 1 cu. decimeter = 1000 cu. centimeters = 61.02 cu. inches
 1 cu. meter = 1000 cu. decimeters = 35.31 cu. feet

Approximate Conversion Factors

To change	To	Multiply by	To change	To	Multiply by
inches	centimeters	2.540	ounce-inches	newton-meters	.007062
feet	meters	.305	centimeters	inches	.394
yards	meters	.914	meters	feet	3.280
miles	kilometers	1.609	meters	yards	1.094
square inches	square centimeters	6.451	kilometers	miles	.621
square feet	square meters	.093	square centimeters	square inches	.155
square yards	square meters	.836	square meters	square feet	10.764
square miles	square kilometers	2.590	square meters	square yards	1.196
acres	square hectometers	.405	square kilometers	square miles	.386
cubic feet	cubic meters	.028	square hectometers	acres	2.471
cubic yards	cubic meters	.765	cubic meters	cubic feet	35.315
fluid ounces	milliliters	29.573	cubic meters	cubic yards	1.308
pints	liters	.473	milliliters	fluid ounces	.034
quarts	liters	.946	liters	pints	2.113
gallons	liters	3.785	liters	quarts	1.057
ounces	grams	28.349	liters	gallons	.264
pounds	kilograms	.454	grams	ounces	.035
short tons	metric tons	.907	kilograms	pounds	2.205
pound-feet	newton-meters	1.356	metric tons	short tons	1.102
pound-inches	newton-meters	.11296			

Temperature (Exact)

°F Fahrenheit temperature 5/9 (after subtracting 32) Celsius temperature °C

PIN: 054728-001