

DEPARTMENT OF THE ARMY TECHNICAL BULLETIN

SHOP EQUIPMENT, AUTOMOTIVE MAINTENANCE AND REPAIR,

FIELD MAINTENANCE

(NSN 4910-00-754-0706)

INSTALLATION IN ONE M109A3 SHOP VAN TRUCK,

ONE M35A2 CARGO TRUCK,

AND

TWO M105A2 CARGO TRAILERS

HEADQUARTERS, DEPARTMENT OF THE ARMY

CHANGE

NO. 1

HEADQUARTERS
DEPARTMENT OF THE ARMY
Washington, DC, 12 JAN 87

SHOP EQUIPMENT, AUTOMOTIVE MAINTENANCE AND REPAIR,
FIELD MAINTENANCE
(NSN 4910-00-754-0706)
INSTALLATION IN ONE M109A3 SHOP VAN TRUCK,
ONE M35A2 CARGO TRUCK,
A N D
TWO M105A2 CARGO TRAILERS

TB 9-4910-746-30, 5 September 1984, is changed as follows:

1. Remove old pages and insert new pages as indicated below. New or changed material is indicated by a vertical bar to the left of the changed material. Changed illustration are indicated by a miniature pointing hand highlighting the general area of the change.

Remove Pages

37 and 38
41 and 42

Insert Pages

37 and 38
41 and 42

2. File this change sheet in back of the publication for reference purposes.

By Order of the Secretary of the Army:

JOHN A. WICKHAM, JR.
General, United States Army
Chief of Staff

Official:

R.L. DILWORTH
Brigadier General, United States Army
The Adjutant General

DISTRIBUTION:

To be distributed in accordance with DA Form 12-21, requirements for FSC Group.
4910: Motor Vehicle; Repair Shop SpecializedEquipment.

DEPARTMENT OF THE ARMY TECHNICAL BULLETIN

SHOP EQUIPMENT, AUTOMOTIVE MAINTENANCE

AND REPAIR, FIELD MAINTENANCE

(NSN 4910-00-754-0706)

INSTALLATION IN

ONE M109A3 SHOP VAN TRUCK,

ONE M35A2 CARGO TRUCK,

AND

TWO M105A2 CARGO TRAILERS

Reporting Errors and Recommending Improvements

You can help improve this bulletin. If you find any mistakes or if you know of a way to improve the procedures, please let us know. Mail your letter or DA Form TM 2028 (Recommended Changes to Publications and Blank Forms) direct to: Commander, US Army Armament, Munitions and Chemical Command, ATTN: DRSMC-MAS(R), Rock Island, IL 61299. A reply will be furnished to you.

TABLE OF CONTENTS

Para		Page
1	GENERAL	1
2	WARNINGS AND CAUTIONS	1
3	LOCATION OF EQUIPMENT	1
4	INSTALLATION	8

*This bulletin supersedes TB ORD 444-9, dated 21 November, 1961, w/changes.

LIST OF ILLUSTRATIONS

Figure	Title	Page
1	Shop van truck, M109A3, unit 1.....	15
2	Components to be mounted, floor plan, unit 1, M109A3.....	16
3	Hole dimensions for mounting components, floor plan, unit 1, M109A3.....	17
4	Hole dimensions for strap loops and squareneck bolts, unit 1, M109A3.....	18
5	Hole dimensions for squareneck bolts, unit 1, M109A3.....	19
6	Components to be mounted, unit 1, M109A3, right side elevation.....	20
7	Components to be mounted, unit 1, M109A3, left side elevation.....	21
8	Cargo truck, M35A2, unit 2.....	22
9	Components to be mounted, floor plan, unit 2, M35A2.....	23
10	Components to be mounted, unit 2, M35A2, right side elevation.....	24
11	Components to be mounted, unit 2, M35A2, left side elevation.....	25
12	Hole dimensions for floor mounted equipment, unit 2, M35A2.....	26
13	Hole dimensions for blind rivet nuts and squareneck bolts, unit 2, M35A2, left side of front wall mounted cabinet.....	27
14	Cargo trailer, M105A2, unit 3.....	28
15	Components to be mounted, floor plan, unit 3, M105A2.....	29
16	Hole dimensions for floor mounted equipment, unit 3, M105A2.....	30
17	Cargo trailer, M105A2, unit 4.....	31
18	Components to be mounted, floor plan, unit 4, M105A2.....	32
19	Hole dimensions for floor mounted equipment, floor plan, unit 4, M105A2.....	33
20	Hole dimensions for blind rivet nuts, unit 4, M105A2.....	34
21	Electrical components to be mounted, unit 2, M35A2, top view.....	35
22	Electrical components to be mounted, unit 2, M35A2, right side elevation.....	36
23	Dimensions for components to be mounted, unit 2, M35A2, left side elevation.....	37
24	Electrical schematic, unit 2, M35A2.....	38
25	Power cable assembly, 11021163, unit 2, M35A2.....	39
26	Power cable assembly, 11021164, unit 2, M35A2.....	40
27	Power cable assembly, 11021165, unit 2, M35A2.....	41
28	Power cable assembly, 11021166, unit 2, M35A2.....	42

1. General

a. The instructions contained in this bulletin are to be used as advice and guidance for installation of field maintenance automotive maintenance and repair shop equipment (NSN 4910-00-754-0706) in one M109A3 shop van truck, unit one; one M35A2 cargo truck, unit two; and two M105A2 cargo trailers, units three and four.

b. Slight variations to the installation instructions may be made in accordance with FM 55-30 at the discretion of the officer in charge.

c. Complete lists of items contained in this shop are found in SC 4910-95-CL-A62.

d. Personnel performing this installation should have a practical knowledge of electricity.

e. Items not mentioned in this bulletin, that may be components of this shop, may be stowed in cabinets and drawers or secured in such a manner as to avoid damage in transit.

f. All dimensions, fastener sizes, and hardware sizes are in inches.

g. When entering shop, curbside is at right and roadside is at left.

2. Warnings and Cautions

WARNING

All electrically powered tools and equipment must be grounded prior to use.

CAUTION

Special care should be exercised to avoid damage to electrical connectors, wiring, or electrical equipment.

To preserve waterproof characteristics, precautions should be taken not to puncture the outer skin when drilling holes in the walls or floor of the shop. Coat underside of vehicle body with coating compound (UNDER-COATING TT-C-520, NSN 8030-00-221-1834) where mounting hardware projects through floor.

3. Location of Equipment

a. Locations of equipment to be installed or stowed in units 1 thru 4 are referenced in figures 1 thru 18.

(1) Refer to table 1 for hardware required for installation.

(2) Refer to table 2 for components to be mounted.

(3) Refer to table 3 for electrical components to be mounted.

b. Refer to table 4 for standard conversion chart.

3. Location of Equipment--Continued

Table 1. Mounting Hardware

MS/part no.	Size and description	Qty	Application
MS3367-3	12.00-in. Tiedown Strap	28	Electrical installation
MS16992-521	5/16-in. Hex Head Lag Bolt x 1-1/4 L	8	Storage cabinets
MS16992-540	3/8-in. Hex Head Lag Bolt x 1-1/4 L	24	Work tables
MS27130-A20	#10-24 UNC Blind Rivet Nut	24	Strap loops, van walls, storage cabinets
MS27183-11	5/16-in. Flat Washer	19	Work tables to angle iron, utility grind- ing machine
MS27183-13	3/8-in. Flat Washer	64	Storage cabinets, work tables, electrical power cable assem- blies, truck slat
MS27183-17	1/2-in. Flat Washer	12	Machinist's vise
MS35190-275	#10-24 UNC-2A Countersunk Head Machine Screw x 1.00 L	64	Strap loops, storage cabinets, van walls
MS35338-43	#10 Lockwasher	40	Strap loops, trailer floor, truck floor
MS35338-45	5/16-in. Lockwasher	35	Work tables to angle iron, utility grind- ing machine, storage cabinets, steam cleaner
MS35338-46	3/8-in. Lockwasher	74	Storage cabinets, work tables, electrical power cable assemblies, truck slat
MS35338-47	7/16-in. Lockwasher	10	Truck bows

3. Location of Equipment--Continued

Table 1. Mounting Hardware--Continued

MS/part no.	Size and description	Qty	Application
MS35338-48	1/2-in. Lockwasher	16	Machinist's vise, diesel engine generator set
MS35649-202	#10-24 UNC-2B Hex Nut	40	Strap loops, trailer floor, truck floor
MS35751-89	3/8-16 UNC-2A Squareneck Bolt x 8.00 L	10	Storage cabinets, electrical power cable assemblies
MS35751-91	3/8-16 UNC-2A Squareneck Bolt x 9.00 L	4	Truck slat
MS51861-49	#10 Thread Forming Screw x 1.00 L	20	Electrical installation
MS51939-3	Strap Loop	32	Storage cabinets, truck floor, trailer floor, walls
MS51967-5	5/16-18 UNC-2B Hex Nut	19	Work tables to angle iron, utility grinding machine
MS51967-8	3/8-16 UNC-2B Hex Nut	64	Storage cabinets, electrical power cable assemblies, work tables, truck slat
MS51967-11	7/16-14 UNC-2B Hex Nut	10	Truck bows
MS51967-14	1/2-13 UNC-2B Hex Nut	16	Machinist's vise, diesel engine generator set
MS51968-5	5/16-24 UNF-2B Hex Nut	8	Steam cleaner
MS90725-35	5/16-18 UNC-2A Hex Head Capscrew x 1-1/8 L	16	Work tables to angle iron
MS90725-38	5/16-18 UNC-2A-18 Hex Head Capscrew x 1-1/4 L	3	Utility grinding machine

3. Location of Equipment--Continued

Table 1. Mounting Hardware--Continued

MS/part no.	Size and description	Qty	Application
MS90725-61	3/8-16 UNC-2A Hex Head Capscrew x 1-1/8 L	36	Storage cabinet, work tables
MS90725-88	7/16-14 UNC-2A Hex Head Capscrew x 1-3/8 L	10	Truck bows
MS90725-113	1/2-13 UNC-2A Hex Head Capscrew x 1-1/2 L	4	Diesel engine generator set
MS90725-115	1/2-13 UNC-2A Hex Head Capscrew x 2.00 L	12	Machinist's vise
NAS3105-24-20	5/16-24 UNF-2A U-Bolt	4	Steam cleaner
7550588-2	60.00-in. Retaining Strap	3	Portable tool box, hydraulic jacks
7550588-3	48.00-in. Retaining Strap	6	Transmission and differential lift, liquid measures, hydraulic jacks
7550588-5	24.00-in. Retaining Strap	7	Crowbar, engine and transmission slings, disk sander, automotive maintenance hoisting unit
7550588-7	92.00-in. Retaining Strap	9	Wash pans, drain pans, hydraulic dolly type jack, engine transport stands
7550588-9	66.00-in. Retaining Strap	3	Liquid measures, wash pans
7550588-10	110.00-in. Retaining Strap	1	Hydraulic jack kit

3. Location of Equipment--Continued

Table 2. Components to be Mounted

NSN	Qty	Description	Figure no.
7125-00-330-0130	4	CABINET, STORAGE	2-6-7-9-11
4910-00-800-1405	2	CABLE ASSEMBLY, POWER, ELECTRICAL: 7 ft	2-6
4910-00-725-9558	2	CABLE ASSEMBLY, POWER, ELECTRICAL: 25 ft	2-6
6150-00-682-3460	6	CABLE ASSEMBLY, POWER, ELECTRICAL: 50 ft	2-6-9-10
2590-00-148-7961	1	CABLE KIT, SPECIAL PURPOSE	2-6
4940-00-186-0027	1	CLEANER, STEAM, PRESSURE JET, TRAILER MOUNTED	18
5120-00-224-1390	1	CROWBAR: 1-1/4-in. dia, 59 in. to 69 in. 1g	15
6115-00-465-1044	1	GENERATOR SET, DIESEL ENGINE	15
3415-00-255-2683	1	GRIINDING MACHINE, UTILITY	2-7
4910-00-448-0254	1	HOISTING UNIT, AUTOMOTIVE MAINTENANCE	9
4910-00-289-7233	2	JACK, DOLLY TYPE, HYDRAULIC: 10-ton	15
5120-00-595-8396	4	JACK, HYDRAULIC, HAND: 8-ton	2-6-18
5120-00-224-7330	2	JACK, HYDRAULIC, HAND: 12-ton	2-6-10
5120-00-188-1790	1	JACK, HYDRAULIC, HAND: 30-ton	18
5120-00-595-8387	1	JACK KIT, HYDRAULIC, HAND: 20-ton	15
2540-00-641-0187	2	LADDER, VEHICLE BOARDING	2-9
4910-00-585-3622	1	LIFT, TRANSMISSION AND DIFFERENTIAL	9
6230-00-268-9436	4	LIGHT, EXTENSION: 115/250 v ac	2-6-9-11

3. Location of Equipment--Continued

Table 2. Components to be Mounted--Continued

NSN	Qty	Description	Figure no.
6230-00-729-9259	9	LIGHT, EXTENSION: 24 ft, 3 condct	9-11
7240-00-233-6013	2	MEASURE, LIQUID: 1-qt	2-10
7240-00-255-8113	2	MEASURE, LIQUID: 2-qt	2-10
7240-00-255-5996	1	MEASURE, LIQUID: 8-qt	2
5340-00-682-1508	4	PADLOCK: 1-1/2 in. w, 1-1/4 in. h	6-9
4910-00-387-9592	4	PAN, DRAIN	11
4940-00-795-3595	20	PAN, WASH	7-11-18
5130-00-560-9728	1	SNIDER, DISK, ELECTRIC, PORTABLE	9-10
4910-00-944-4915	2	SLING, ENGINE AND TRANSMISSION, MOTOR VEHICLE	10
4910-00-338-6673	2	STAND, TRANSPORT, ENGINE	18
4910-00-357-5342	7	TABLE, WORK	2-6-7-9 thru 12
5140-00-315-2758	1	TOOL BOX, PORTABLE	9-11
5120-00-293-1439	2	VISE, MACHINIST'S: 4-in.	2-6-9-10
5120-00-223-1945	1	VISE, MACHINIST'S: 6-in.	2-7

3. Location of Equipment--Continued

Table 3. Electrical Components to be Mounted

Part No. or Speci fi cati on	Qty	Descri pti on	Fi gure no.
APPLETON 15233	16	BOX CONNECTOR: type I, class 4, style M, strain relief type (w-F-406)	22-24 thru 28
4910-00-800-1405	1	CABLE ASSEMBLY, ELECTRICAL POWER: MIL-C-45820	22
11021163	1	CABLE ASSEMBLY, POWER: consisting of one each of the following: 44-in. flex. cord (J-C-580) connector (W-C-596/92-1) box connector (W-F-406)	21-23 thru 25
11021164	1	CABLE ASSEMBLY, POWER: consisting of one each of the following: 44-in. flex. cord (J-C-580) plug (W-C-596/91-1) box connector (w-F-406)	21-23- 24-26
11021165	1	CABLE ASSEMBLY, POWER: consisting of one each of the following: 37.50-in. flex. cord (J-C-580) plug (W-C-596/91-1) box connector (W-F-406)	21-22- 24-27
11021166	1	CABLE ASSEMBLY, POWER: consisting of one each of the following: 37.50-in. flex. cord (J-C-580) connector (W-C-596-92-1) box connector (W-F-406)	21-22- 24-28
GE-GLD0533	2	CONNECTOR, CABLE OUTLET: 2-pole, 3-wire, 30 amp, grounding, 125 v, 50/60 Hz (W-C-596/92-1) (General Electric)	25-28
GE-GLD0531	2	CONNECTOR, PLUG: straight, grounding, 2-pole, 3-wire, 30 amp, 125 v, 50/60 Hz (W-C-596/91-1) (General Electric)	26-27
6145-00-295-0855	42 ft	CORD, FLEXIBLE: type S06CF3/10SRNJG (J-C-580)	21 thru 28
APPLETON 2510	4	COVER, JUNCTION BOX, DUPLEX: type VIII, size F, style 59, (W-J-800)	22-23

3. Location of Equipment--Continued

Table 3. Electrical Components to be Mounted--Continued

Part No. or Specification	Qty	Description	Figure no.
5975-00-281-0090	4	JUNCTION BOX, DUPLEX: type II (W-J-800)	21 thru 24
APPLETON 40-3/4	4	JUNCTION BOX, LAMPHOLDER: type I (W-J-800)	21 thru 24
GE-5740-7	4	LAMPHOLDER (General Electric)	22-23
5935-01-058-9269	4	RECEPTACLE, DUPLEX, GROUNDED: 2-pole, 3-wire (W-C-596/40)	22-23-24
SQUARE D D221NRB	1	SWITCH BOX (ENCLOSED) : surface mtd type NDS, class 2, design 2SN box, 120/240 v ac, 30 amp (W-S-865)	21-22-24
MS20659-141	27	TERMINAL LUG	24

4. Installation

NOTE

Hand blind riveter (5120-00-679-6523) is used for installing blind rivet nuts in unit floors and walls. Install blind rivet nuts in accordance with MIL-N-47187.

Position floor, table, and cabinet mounted equipment as shown in figures 2 thru 23. Use the equipment mounting holes as templates for location of blind rivet nuts and fasteners. Positions may be varied to drill into structural members in fixed floor.

a. Install blind rivet nuts in walls as follows:

(1) Unit 1. Mark and drill four 0.25-in. diameter holes in right wall in accordance with figure 6. Install

four #10 blind rivet nuts (MS27130-A20) in holes. Secure two strap loops (MS51939-3) to wall (fig. 6) with four #10 x 1-in. countersunk head machine screws (MS35190-275).

(2) Unit 4. Mark and drill four 0.25-in. diameter holes in front wall in accordance with figure 20. Install four #10 blind rivet nuts (MS27130-A20) in holes. Secure two strap loops (MS51939-3) to wall with four #10 x 1-in. countersunk head machine screws (MS35190-275) in accordance with figure 18.

b. Install strap loops on floors as follows:

(1) Unit 2. Mark and drill eight 0.22-in. diameter holes through truck floor in accordance with figure 12. Secure four strap loops (MS51939-3) to the truck floor with eight #10 x 1-in. countersunk head machine screws (MS35190-275), eight #10 lockwashers (MS35338-43), and eight #10 hex nuts (MS35649-202) in accordance with figure 11.

4. Installation--Continued

(2) Unit 3. Mark and drill twelve 0.22-in. diameter holes through trailer floor in accordance with figure 16. Secure six strap loops (MS51939-3) to trailer floor with twelve #10 x 1-in. countersunk head machine screws (MS35190-275), twelve #10 lockwashers (MS35338-43), and twelve #10 hex nuts (MS35649-202) in accordance with figure 15.

(3) Unit 4. Mark and drill twenty 0.22-in. diameter holes through trailer floor in accordance with figure 19. Secure ten strap loops (MS51939-3) to trailer floor with twenty #10 x 1-in. countersunk head machine screws (MS35190-275), twenty #10 lockwashers (MS35338-43), and twenty #10 hex nuts (MS35649-202) in accordance with figure 18.

c. Follow steps (1) thru (14) below for equipment installation in unit 1, M109A3 shop van truck.

(1) Mark and drill sixteen 0.34-in. diameter holes through horizontal legs of two factory-furnished angle irons in accordance with figure 2. Position three work tables (4910-00-357-5342) in accordance with figures 2, 6, and 7 under factory-furnished angle irons. Using the work tables as templates, mark and drill twenty-four 0.27-in. diameter holes through table legs and 1.00 inch deep into van floor in accordance with figure 3. Reposition work tables and secure to van floor using twenty-four 3/8- x 1-1/4-in. hex head lag bolts (MS16992-540) and twenty-four 3/8-in. lockwashers (MS35338-46). Using the drilled angle irons as templates, mark and drill sixteen 0.34-in. diameter holes through tabletops in accordance with figure 2. Secure work tables to angle iron using sixteen 5/16- x 1-1/8-in. hex head capscrews (MS90725-35), sixteen 5/16-in. **flat washers** (MS27183-11), sixteen 5/16-in. lockwashers (MS35338-45), and sixteen 5/16-in. hex nuts (MS51967-5).

(2) Position three storage cabinets (7125-00-330-0130) in van in accordance with figures 2, 6, and 7. Mark and drill eight 0.34-in. diameter holes in bottom plates of storage cabinets (four holes in one storage cabinet and two holes per remaining storage cabinet). Locate at corners, allowing for minimum required clearance for 5/16- x 1-1/4-in. hex head lag bolts. Using storage cabinets as templates, mark and drill eight 0.22-in. diameter pilot holes into van floor 1.00 inch deep. Secure storage cabinets to van floor, using eight 5/16- x 1-1/4-in. hex head lag bolts (MS16992-521) and eight 5/16-in. lockwashers (MS35338-45).

CAUTION

Be sure storage cabinet drawers adjacent to hole locations are removed before drilling.

(3) Mark and drill seven 0.44-in. diameter holes in sides of storage cabinets in accordance with figures 4 and 5. Install seven 3/8- x 8-in. squareneck bolts (MS35751-89) using fourteen 3/8-in. flat washers (MS27183-13), seven 3/8-in. lockwashers (MS35338-46), and fourteen 3/8-in. hex nuts (MS51967-8).

(4) Install three padlocks (5340-00-682-1508) on storage cabinets in accordance with figure 6.

(5) Position electrical power cable assemblies (two 4910-00-800-1405, two 4910-00-725-9558, and three 6150-00-682-3460) and special purpose cable kit (2590-00-148-7961) on cabinet squareneck bolts in accordance with figures 2 and 6.

CAUTION

Be sure storage cabinet drawers adjacent to hole locations are removed before drilling.

4. Installation--Continued

(6) Mark and drill four 0.25-in. diameter holes in left side of front wall mounted storage cabinet in accordance with figure 4. Install four #10 blind rivet nuts (MS27130-A20) in holes. Secure two strap loops (MS51939-3) to storage cabinet using four #10 x 1-in. countersunk head machine screws (MS35190-275).

(7) Position two 8-ton hydraulic jacks (5120-00-595-8396) and 12-ton hydraulic jack (5120-00-224-7330) in accordance with figures 2 and 6. Secure hydraulic jacks to storage cabinet with a 48.00-in. retaining strap (7550588-3).

(8) Position 1-qt liquid measure (7240-00-233-6013), 2-qt liquid measure (7240-00-225-8113), and 8-qt liquid measure (7240-00-255-5996) in van as shown in figure 2. Secure liquid measures to van wall with a 66.00-in. retaining strap (7550588-9) in accordance with figures 2 and 6.

(9) Position 4-in. machinist's vise (5120-00-293-1439) on work table right side in van as shown in figures 2 and 6. Using base of 4-in. machinist's vise as a template, mark and drill four 0.56-in. diameter holes in tabletop. Secure 4-in. machinist's vise to work table with four 1/2- x 2-in. hex head capscrews (MS90725-115), four 1/2-in. flat washers (MS27183-17), four 1/2-in. lockwashers (MS35338-48), and four 1/2-in. hex nuts (MS51967-14).

(10) Position 6-in. machinist's vise (5120-00-223-1945) on work table left side in van as shown in figures 2 and 7. Using the base of the machinist's vise as a template, mark and drill four 0.56-in. diameter holes through tabletop. Secure machinist's vise to tabletop with four 1/2- x 2-in. hex head capscrews (MS90725-115), four 1/2-in. flat washers (MS27183-17), four 1/2-in. lockwashers (MS35338-48), and four 1/2-in. hex nuts (MS51967-14).

(11) Position two 115/250 v ac extension lights (6230-00-268-9436) on squareneck bolt of storage cabinet in accordance with figures 2 and 6.

(12) Position five wash pans (4940-00-795-3595) on table cross braces in accordance with figure 7 and secure in place with a 66.00-in. retaining strap (7550588-9).

(13) Position utility grinding machine (3415-00-255-2683) on work table in accordance with figures 2 and 7. Using base of utility grinding machine as a template, mark and drill three 0.38-in. diameter holes through tabletop. Secure utility grinding machine to tabletop using three 5/16- x 1-1/2-in. hex head capscrews (MS90725-38), three 5/16-in. flat washers (MS27183-11), three 5/16-in. lockwashers (MS35338-45), and three 5/16-in. hex nuts (MS51967-5).

(14) Ladder (2540-00-641-0187) is stowed in frame of van in accordance with figure 2.

d. Follow steps (1) thru (18) below for equipment installation in unit 2, M35A2 cargo truck.

(1) Position four work tables (4910-00-357-5342) in truck in accordance with figure 9. Using work tables as templates, mark and drill thirty-two 0.44-in. diameter holes through table legs and truck floor in accordance with figure 12. Secure work tables to truck floor using thirty-two 3/8- x 1-1/8-in. hex head capscrews (MS90725-61), thirty-two 3/8-in. flat washers (MS27183-13), thirty-two 3/8-in. lockwashers (MS35338-46), and thirty-two 3/8-in. hex nuts (MS51967-8).

CAUTION

Be sure storage cabinet drawers adjacent to hole locations are removed before drilling.

4. Installation--Continued

(2) Position a storage cabinet (7125-0-330-0130) in truck in accordance with figures 9 and 10. Mark and drill four 0.44-in. diameter holes in bottom plate of storage cabinet. Locate at four corners, allowing for minimum required clearance for 3/8- x 1-1/8-in. hex head capscrews. Using storage cabinet as a template, mark and drill four 0.39-in. diameter holes through truck floor in accordance with figure 12. Secure to truck floor with four 3/8- x 1-1/8-in. hex head capscrews (MS90725-61), four 3/8-in. flat washers (MS27183-13), four 3/8-in. lockwashers (MS35338-46), and four 3/8-in. hex nuts (MS51967-8).

CAUTION

Be sure storage cabinet drawers adjacent to hole locations are removed before drilling.

(3) Mark and drill three 0.44-in. diameter holes in left side of storage cabinet in accordance with figure 13. Install three 3/8- x 8-in. squareneck bolts (MS35751-89), six 3/8-in. flat washers (MS27183-13), three 3/8-in. lockwashers (MS35338-46), and six 3/8-in. hex nuts (MS51967-8).

(4) Install padlock (5340-00-682-1508) on storage cabinet in accordance with figure 9.

(5) Position three electrical power cable assemblies (6150-00-682-3460) on squareneck bolts in accordance with figures 9 and 10.

CAUTION

Be sure storage cabinet drawers adjacent to hole locations are removed before drilling.

(6) Mark and drill twelve 0.25-in. diameter holes in left side of storage cabinet in accordance with figure 13. Install twelve #10 blind

rivet nuts (MS27130-A20). Secure six strap loops (MS51939-3) to storage cabinet using twelve #10 x 1-in. counter-sunk head machine screws (MS35190-275).

(7) Position 4-in. machinist's vise (5120-00-293-1439) on work table right side in truck as shown in figures 9 and 10. Using the base of the machinist's vise as a template, mark and drill four 0.56-in. diameter holes through tabletop. Secure machinist's vise to work table with four 1/2- x 2-in. hex head capscrews (MS90725-115), four 1/2-in. flat washers (MS27183-17), four 1/2-in. lockwashers (MS35338-48), and four 1/2-in. hex nuts (MS51967-14).

(8) Position 1-qt liquid measure (7240-00-233-6013), 2-qt liquid measure (7240-00-255-8113), and 12-ton hydraulic jack (5120-00-224-7330) in accordance with figure 10. Secure liquid measures and hydraulic jack to storage cabinet using three 48.00-in. retaining straps (7550588-3).

(9) Position five wash pans (4940-00-795-3595) and secure to work table cross braces using one 66.00-in. retaining strap (7550588-9) in accordance with figure 11.

(10) Position four drain pans (4910-00-387-9592) and secure to work table cross braces using two 92.00-in. retaining straps (7550588-7) in accordance with figure 11.

(11) Locate portable tool box (5140-00-315-2758) in accordance with figures 9 and 11 and secure with two 60.00-in. retaining straps (7550588-2).

(12) Mark and drill four 0.38-in. diameter holes in truck slat in accordance with figure 11. Install four 3/8- x 9-in. squareneck bolts (MS35751-91) to truck slats using eight 3/8-in. flat washers (MS27183-13), four 3/8-in. lockwashers (MS35338-46), and eight 3/8-in. hex nuts (MS51967-8).

4. Installation--Continued

(13) Locate disk sander (5130-00-560-9728) on work table and secure to truck slat with a 24.00-in. retaining strap (7550588-5) in accordance with figures 9 and 10.

(14) Locate automotive maintenance hoisting unit (4910-00-448-0254) and secure to table cross brace with two 24.00-in. retaining straps (7550588-5) in accordance with figure 9.

(15) Locate transmission and differential lift (4910-00-585-3622) in truck and secure to table cross braces with two 48.00-in. retaining straps (7550588-3) in accordance with figure 9.

(16) Position two 115/250 v ac extension lights (6230-00-268-9436) and nine 25-ft extension lights (6230-00-729-9259) on squareneck bolts on left wall in truck in accordance with figures 9 and 11.

(17) Locate two engine and transmission slings (4910-00-944-4915) in truck and secure to truck slat with two 24.00-in. retaining straps (7550588-5) in accordance with figure 10.

(18) Ladder (2540-00-641-0187) is stowed in frame of truck in accordance with figure 9.

e. Follow steps (1) thru (4) below for equipment installation in unit 3, M105A2 cargo trailer.

(1) Locate diesel engine generator set (6115-00-465-1044) in trailer in accordance with figure 15. Using base of diesel engine generator set as a template, mark and drill four 0.56-in. holes through trailer floor in accordance with figure 16. Secure using four 1/2- x 1-1/2-in. hex head capscrews (MS90725-113), four 1/2-in. lockwashers (MS35338-48), and four 1/2-in. hex nuts (MS51967-14).

(2) Secure two hydraulic dolly type jacks (4910-00-289-7233) using two 92.00-in. retaining straps (7550588-7) in accordance with figure 15.

(3) Position crowbar (5120-00-224-1390) by securing to trailer slat using two 24.00-in. retaining straps (7550588-5) in accordance with figure 15.

(4) Secure 20-ton hydraulic jack kit (5120-00-595-8387) to trailer floor using a 110.00-in. retaining strap (7550588-10) in accordance with figure 15.

f. Follow steps (1) thru (4) below for equipment installation in unit 4, M105A2 cargo trailer.

(1) Position 30-ton hydraulic jack (5120-00-188-1790) and two 8-ton hydraulic jacks (5120-00-595-8396) on front wall in accordance with figure 18. Secure using a 60.00-in. retaining strap (7550588-2).

(2) Position ten wash pans (4940-00-795-3595) in accordance with figure 18. Secure using a 92.00-in. retaining strap (7550588-7).

(3) Position steam cleaner (4940-00-186-0027) on floor of trailer in accordance with figure 18. Using tubular skid as a template, mark and drill eight 0.39-in. diameter holes through floor in accordance with figure 19. Secure steam cleaner using four U-bolts (NAS3105-24-20), eight 5/16-in. lockwashers (MS35338-45), and eight 5/16-in. hex nuts (MS51968-5). (U-bolts and hex nuts have UNF threads.)

(4) Position and secure two engine transport stands (4910-00-338-6673) in accordance with figure 18. Secure using four 92.00-in. retaining straps (7550588-7).

4. Installation--Continued

g. Follow steps (1) thru (14) below for electrical component installation in unit 2, M35A2 cargo truck.

(1) To provide sufficient head-room for personnel to work in the M35A2 cargo truck, raise the bows 18 inches and drill ten 0.44-in. diameter holes through bow sockets and bows in accordance with figures 22 and 23.

(2) Secure bows in place with ten 7/16- x 1-3/8-in. hex head capscrews (MS90725-88), ten 7/16-in. lockwashers (MS35338-47), and ten 7/16-in. hex nuts (MS51967-11).

(3) Position switch box (Square D D221NRB) on the two top slats in accordance with figure 22. Using holes of switch box as a template, mark and drill four 0.12-in. diameter pilot holes. Secure switch box to truck slat with four #10 x 1-in. thread forming screws (MS51861-49).

(4) Install electrical power cable assembly (4910-00-800-1405) through box connector in bottom of switch box and connect to circuit breaker inside switch box in accordance with figure 22.

(5) Position four lampholder junction boxes (Appleton 40-3/4) on inner side of second and fourth bows as in shown in figure 21. Mark and drill eight 0.12-in. diameter pilot holes and secure lampholder junction boxes to bows with eight #10 x 1-in. thread forming screws (MS51861-49).

(6) Position four duplex junction boxes (5975-00-281-0090) on bows as shown in figures 22 and 23. Mark and drill eight 0.12-in. diameter pilot holes and secure duplex junction boxes to bows with eight #10 x 1-in. thread forming screws (MS51861-49).

(7) Remove two knockout slugs from each lampholder junction box and

each duplex junction box in line with bows. Install twelve box connectors (Appleton 15233) in the junction boxes and install jam nuts on connectors in accordance with figure 24.

(8) Fabricate four power cable assemblies (11021163, 11021164, 11021165, and 11021166) using approximately 14 feet of flexible cord (6145-00-295-0855). Install four box connectors (Appleton 15233). Refer to figures 25 thru 28 for individual power cable assembly construction, and install in accordance with figures 21 thru 24.

(9) Install a 28-foot length of flexible cord (6145-00-295-0855) through duplex junction boxes and lampholder junction boxes on second and fourth bows. Refer to figure 24. Strip a 3-inch length of outside insulation from flexible cord on inside of each junction box. Strip 1 inch of insulation from each individual wire and twist wire to fit terminal lugs (MS20659-141). Install and crimp terminal lugs in place in accordance with figure 24.

(10) Connect three wires to one lampholder (GE-5740-7) and secure to lampholder junction box (Appleton 40-3/4) with screws provided with lampholder junction box. Repeat this step for the remaining three lampholder junction boxes. Refer to figures 22 and 23.

(11) Install four grounded duplex receptacles (5935-01-058-9269) after stripping 3 inches of outside insulation from flexible cord. Refer to figure 24. Strip 1 inch of insulation from each individual wire and twist wires to fit terminal lugs (MS20659-141). Install terminal lugs and crimp. Connect wires to grounded duplex receptacles and secure grounded duplex receptacles to duplex junction boxes with screws provided with grounded duplex receptacles in accordance with figures 22 thru 24.

4. Installation--Continued

(12) Install four duplex junction box covers (Appleton 2510) on duplex junction boxes (5975-00-281-0090) and secure with screws provided in duplex junction box covers. Refer to figures 22 thru 24.

(13) Tighten all box connectors (Appleton 15233) to secure flexible

cord in junction boxes and switch box. Refer to figures 21 thru 28.

(14) Secure power cable assemblies to bows and truck rack with twenty-eight 12.00-in. tiedown straps (MS3367-3) in accordance with figures 21 thru 24.

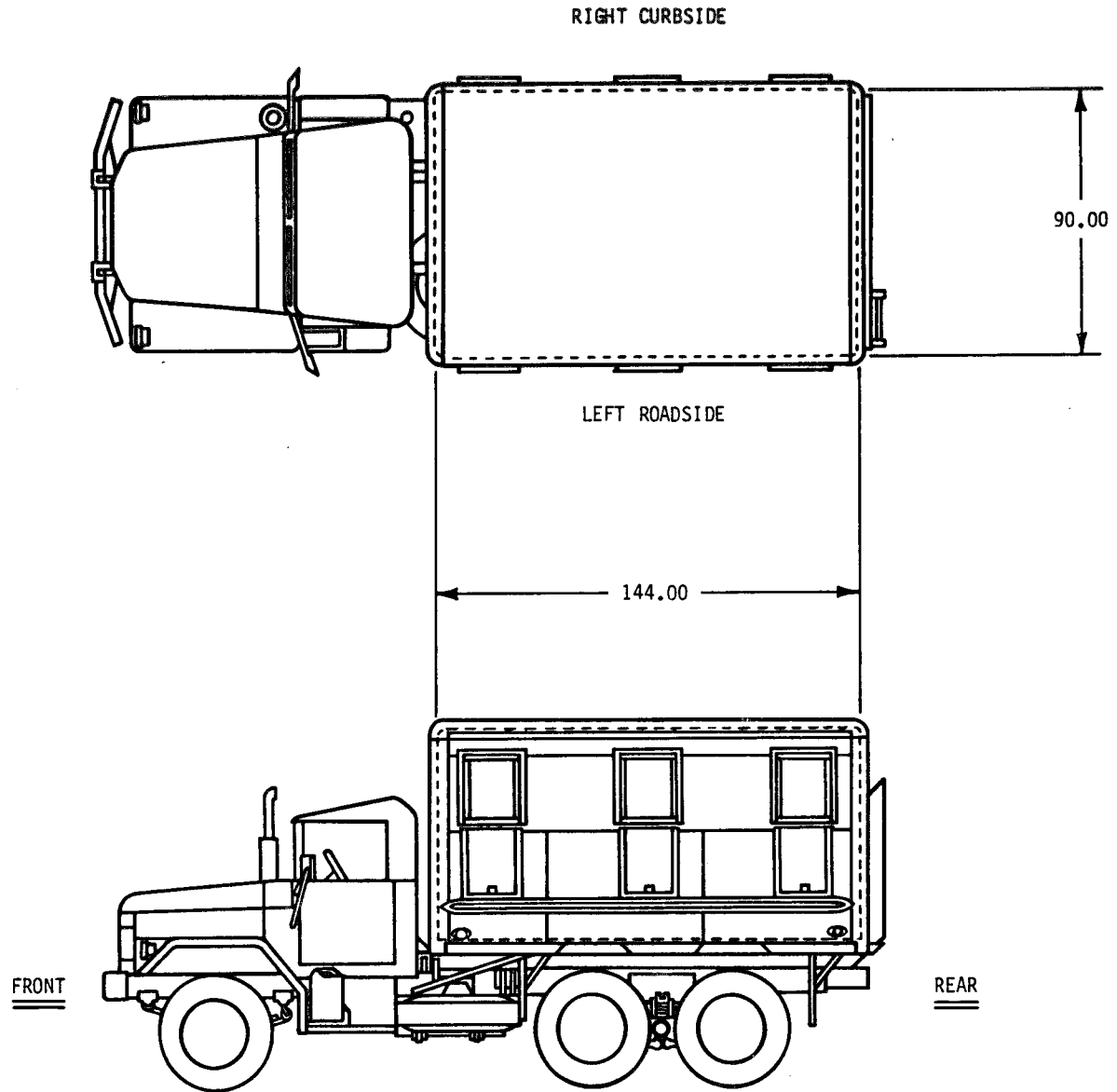

Figure 1. Shop van truck, M109A3, unit 1.
 ←12.00→

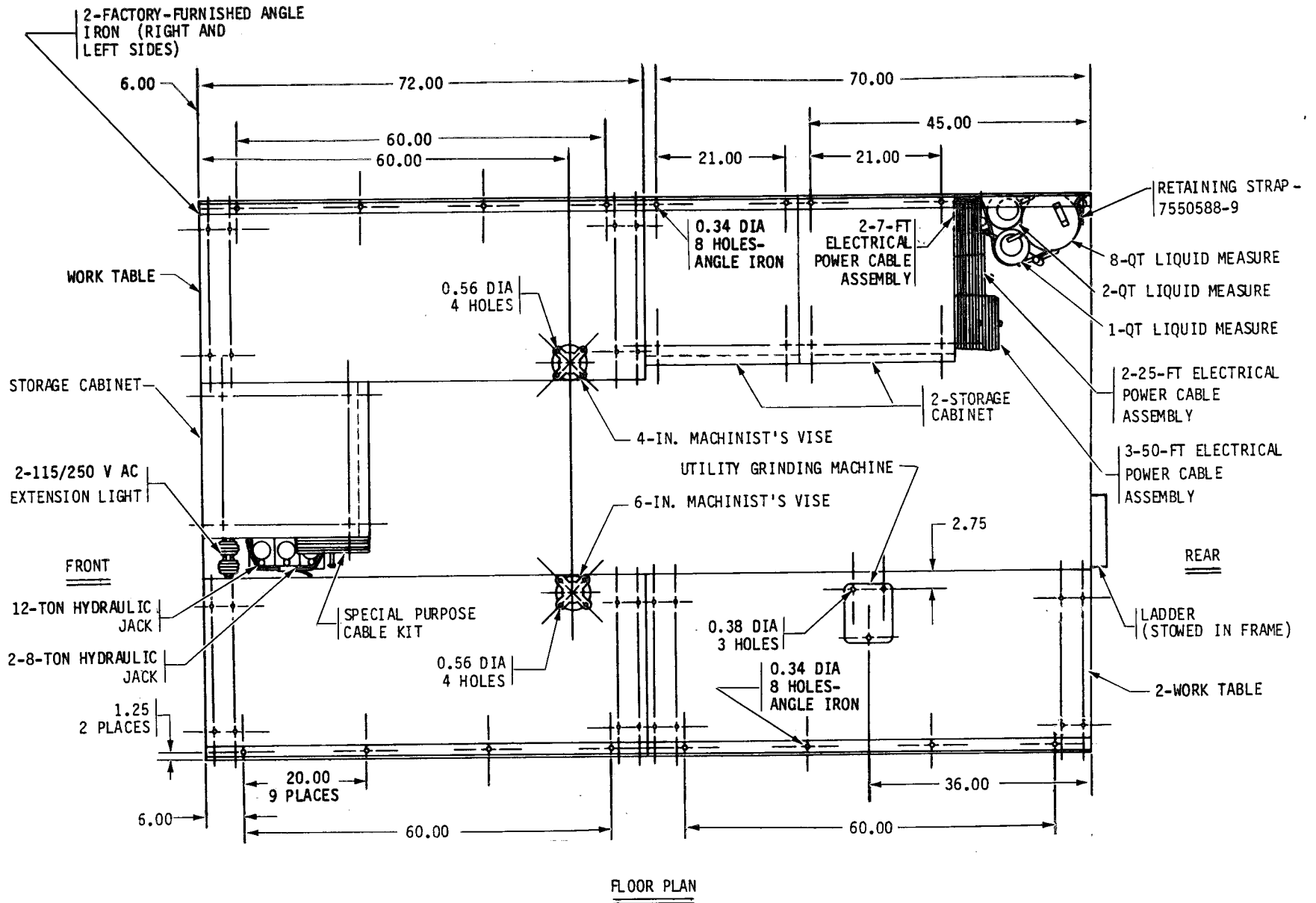

Figure 2. Components to be mounted, floor plan, unit 1, M109A3.

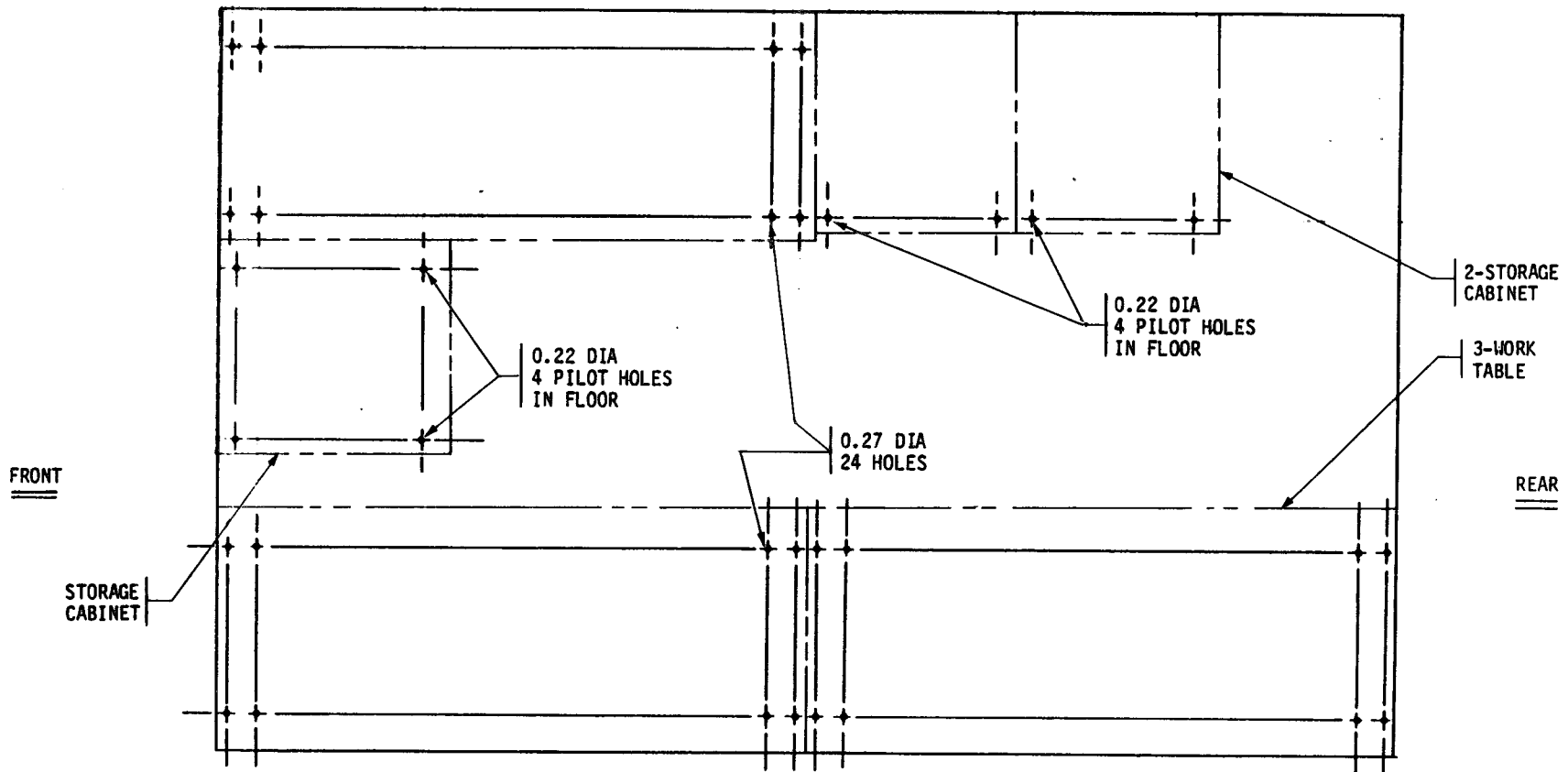

Figure 3. Hole dimensions for mounting components, floor plan, unit 1, M109A3.

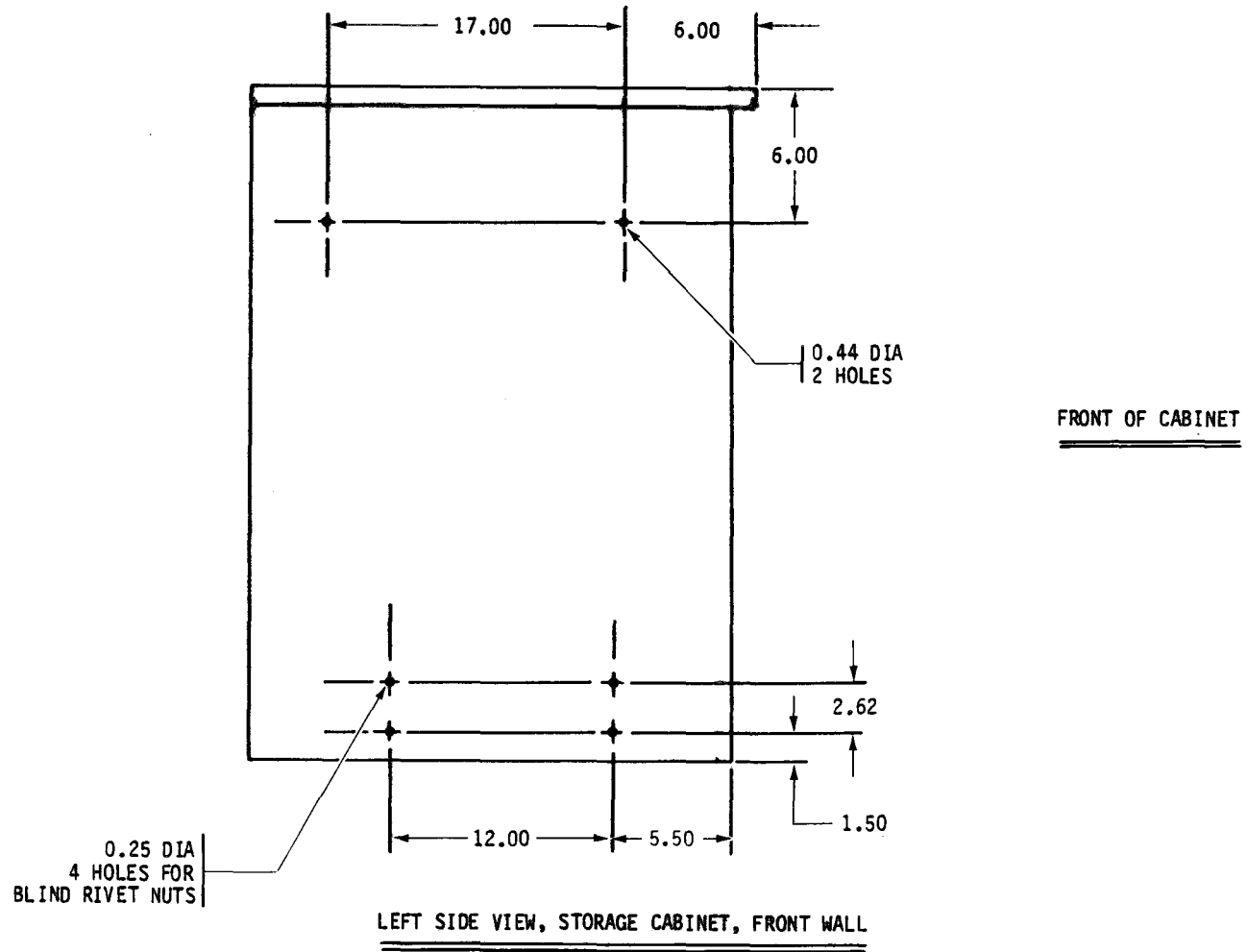
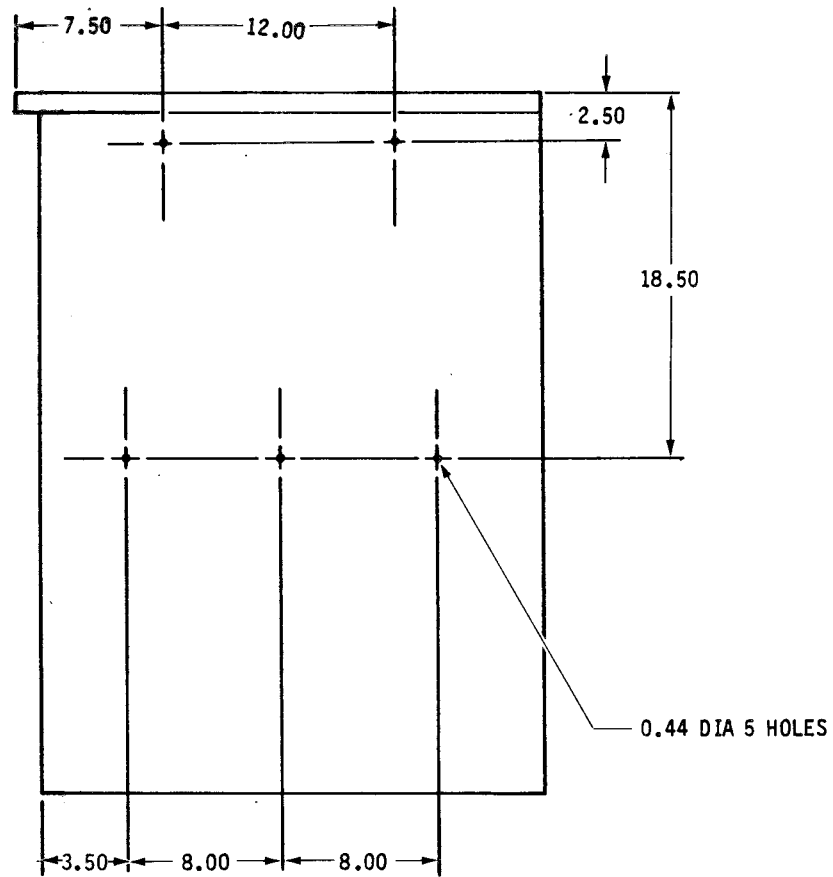

Figure 4. Hole dimensions for strap loops and squareneck bolts, unit 1, M109A3.

FRONT OF CABINET



RIGHT SIDE VIEW, STORAGE CABINET, REAR

Figure 5. Hole dimensions for squareneck bolts, unit 1, M109A3.

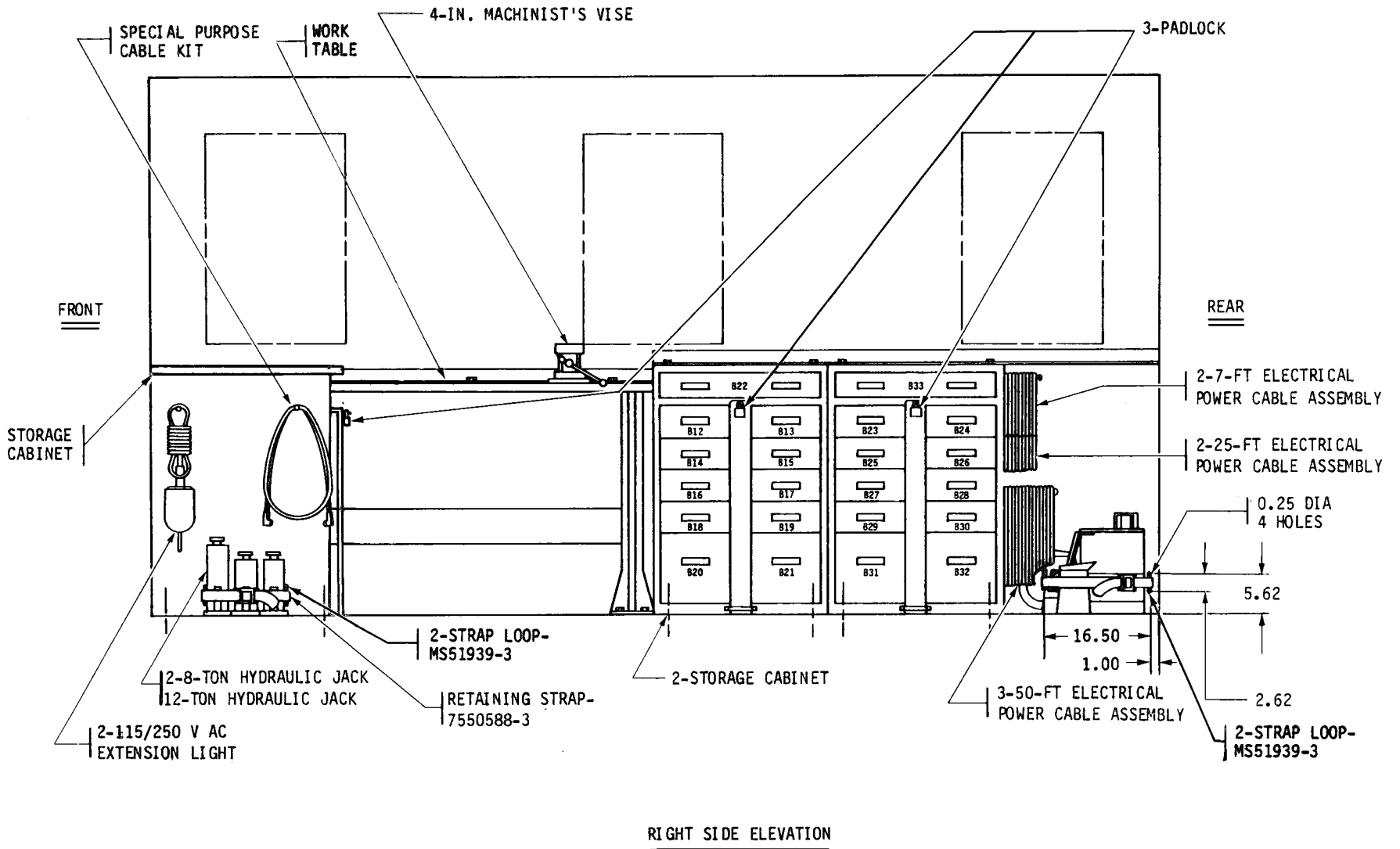

Figure 6. Components to be mounted, unit 1, M109A3, right side elevation.

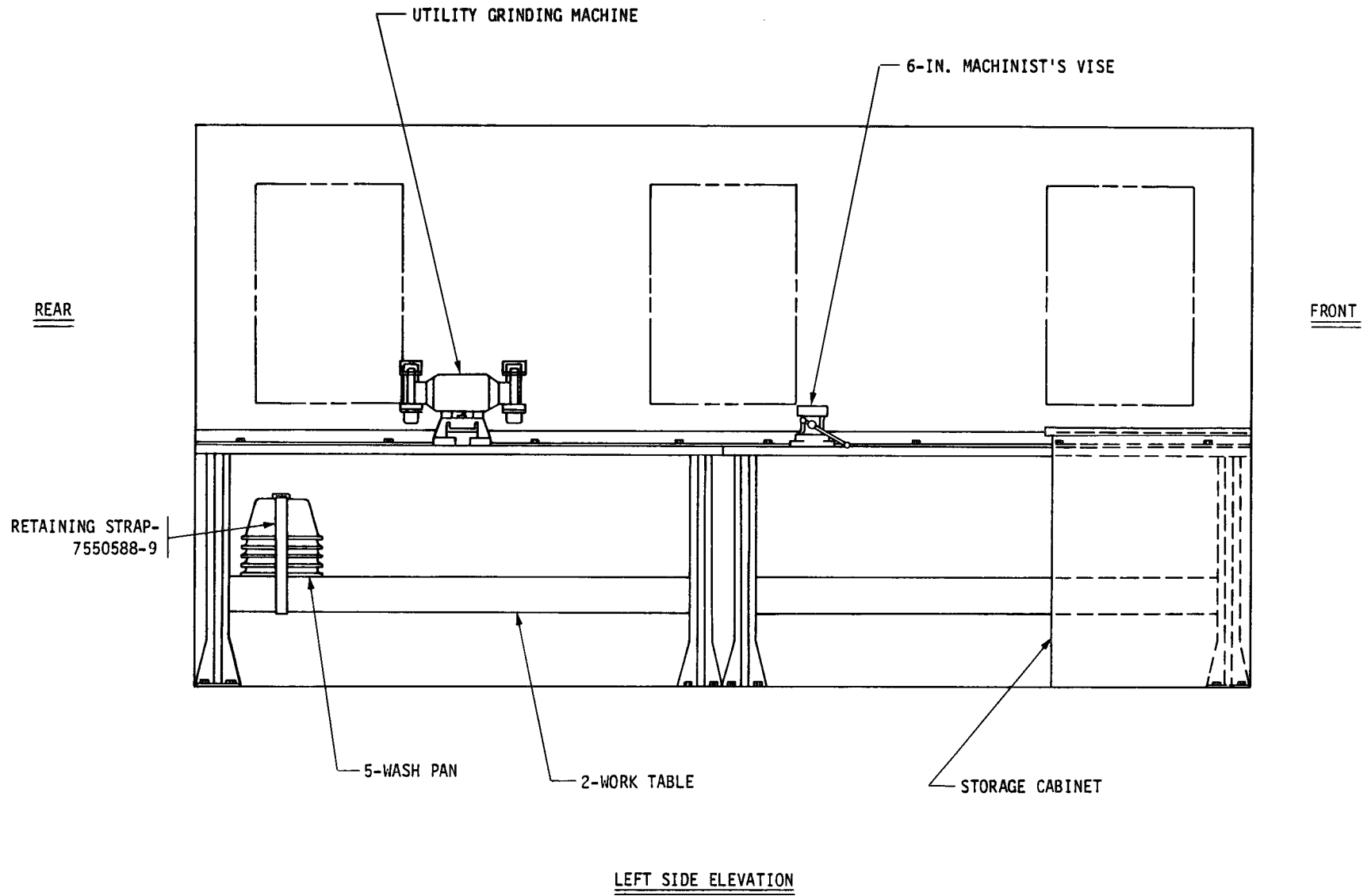

Figure 7. Components to be mounted, unit 1, M109A3, left side elevation.

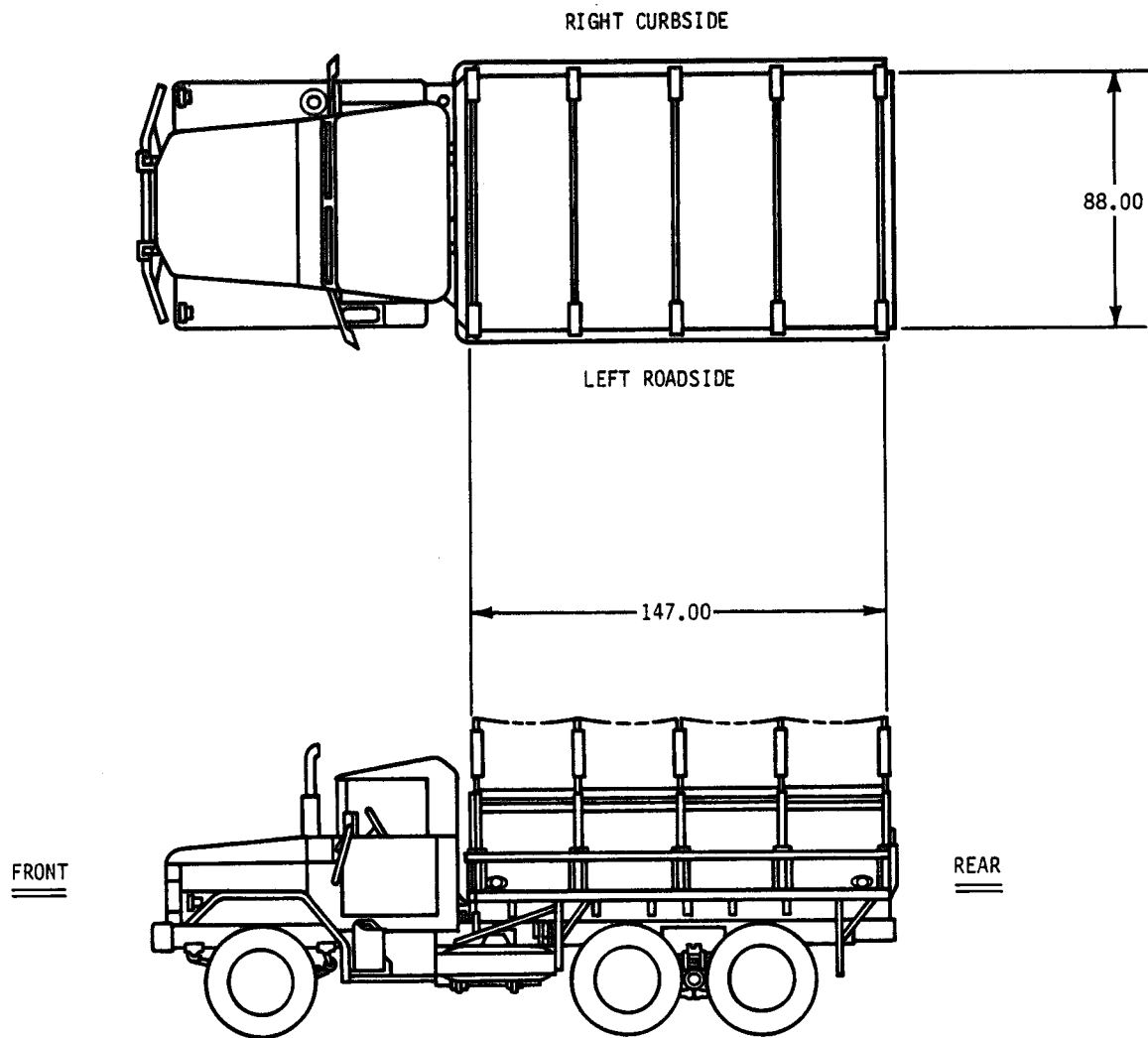

Figure 8. Cargo truck, M35A2, unit 2.

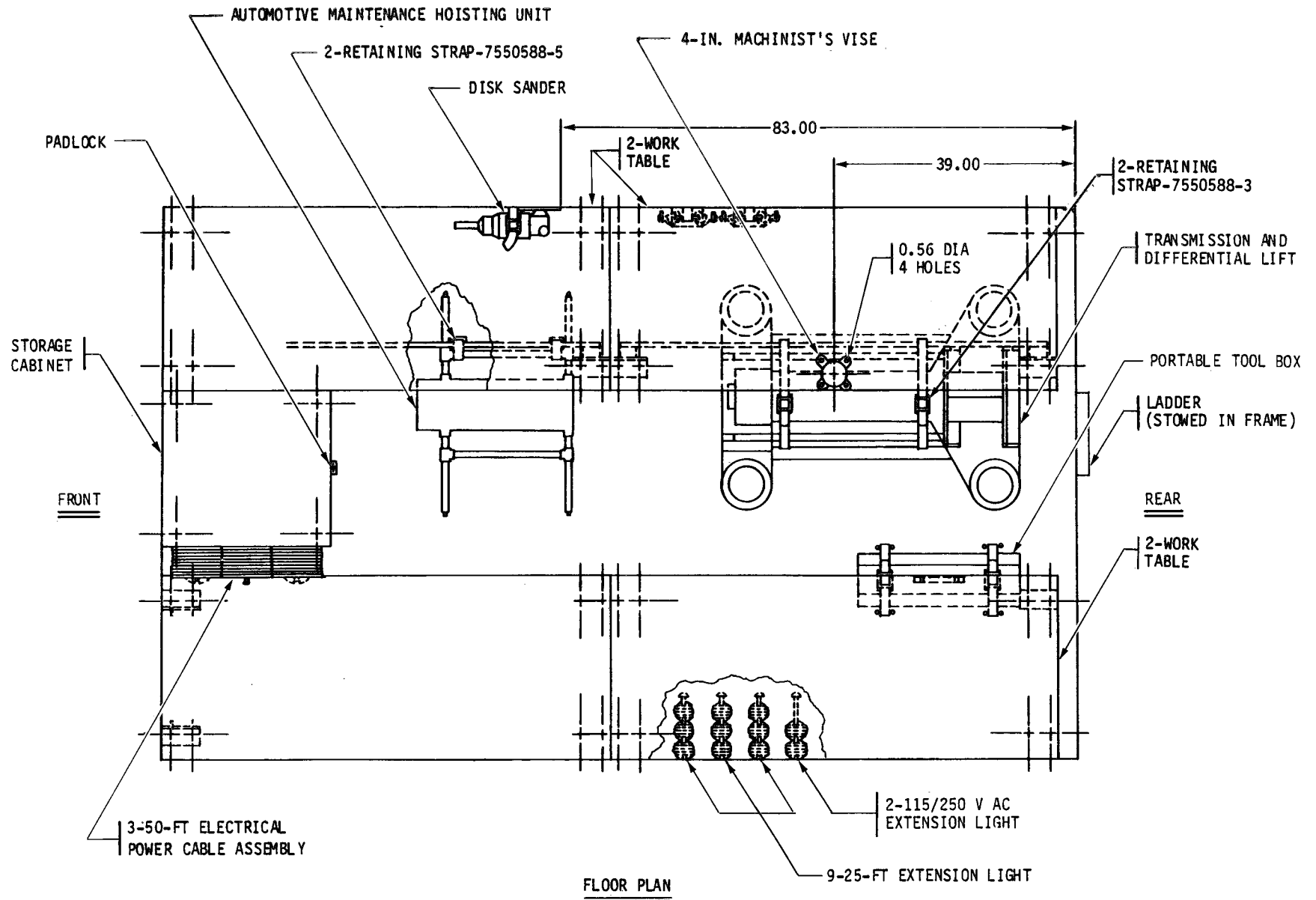

Figure 9. Components to be mounted, floor plan, unit 2, M35A2.

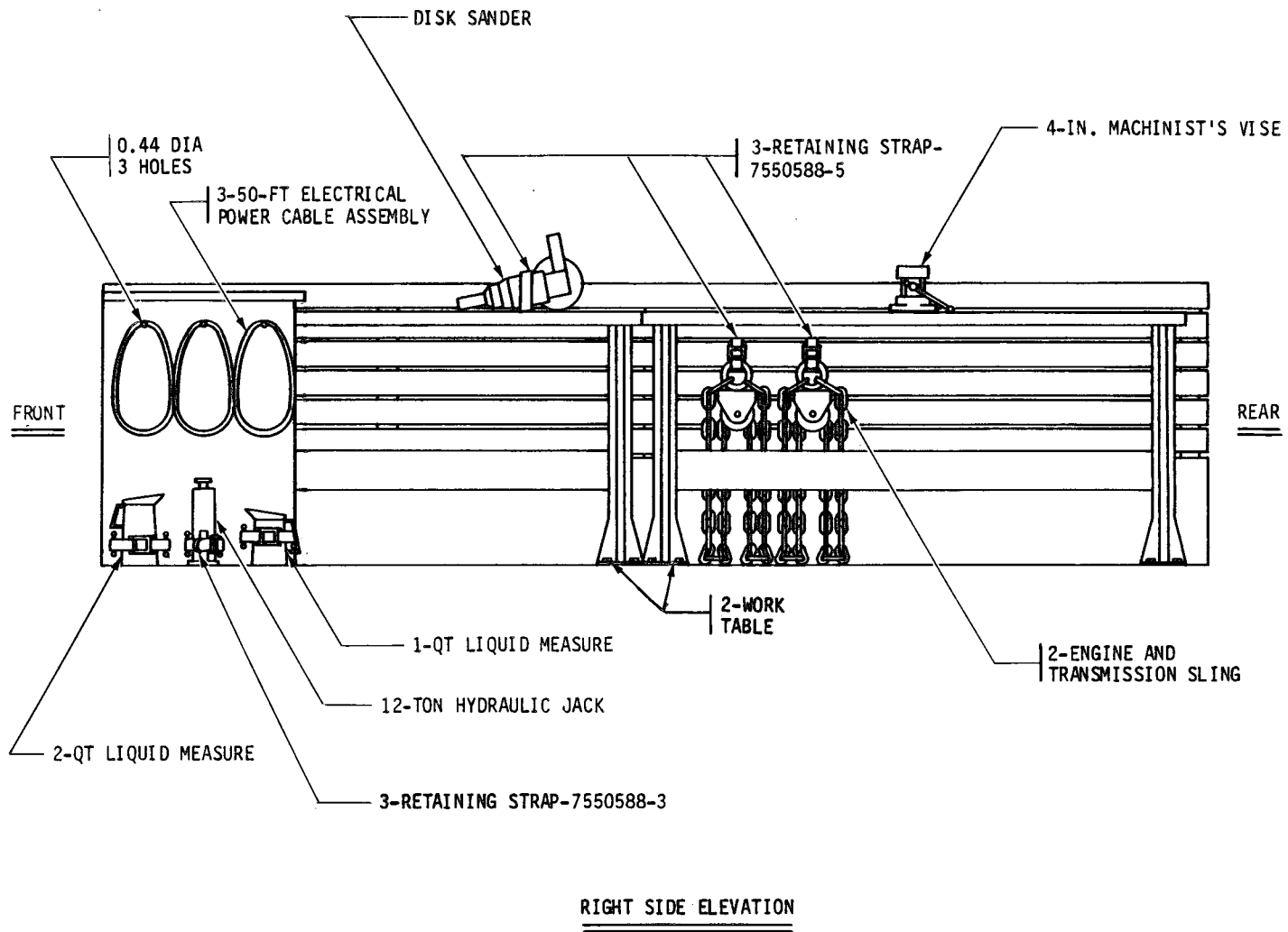

Figure 10. Components to be mounted, unit 2, M35A2, right side elevation.

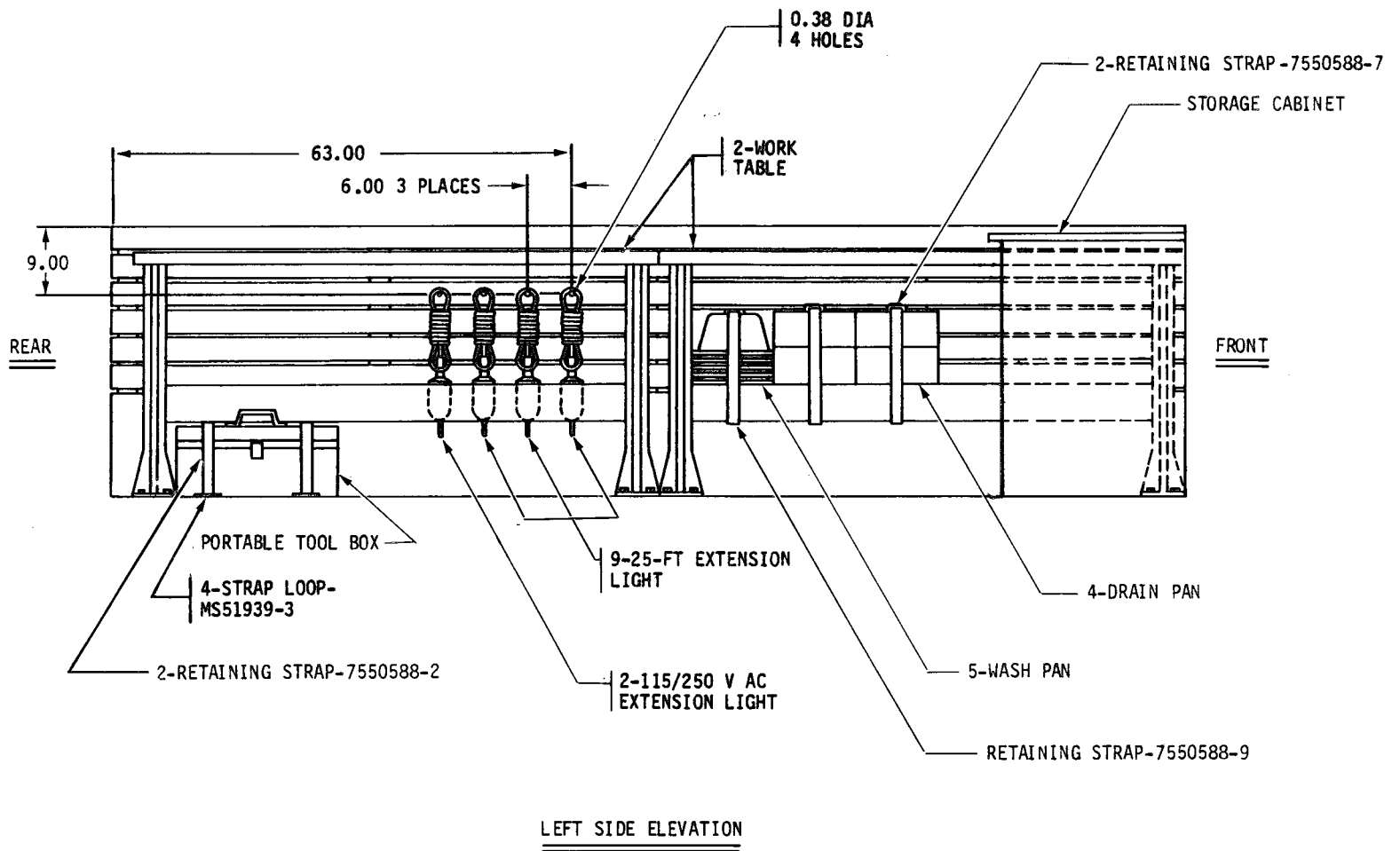

Figure 11. Components to be mounted, unit 2, M35A2, left side elevation.

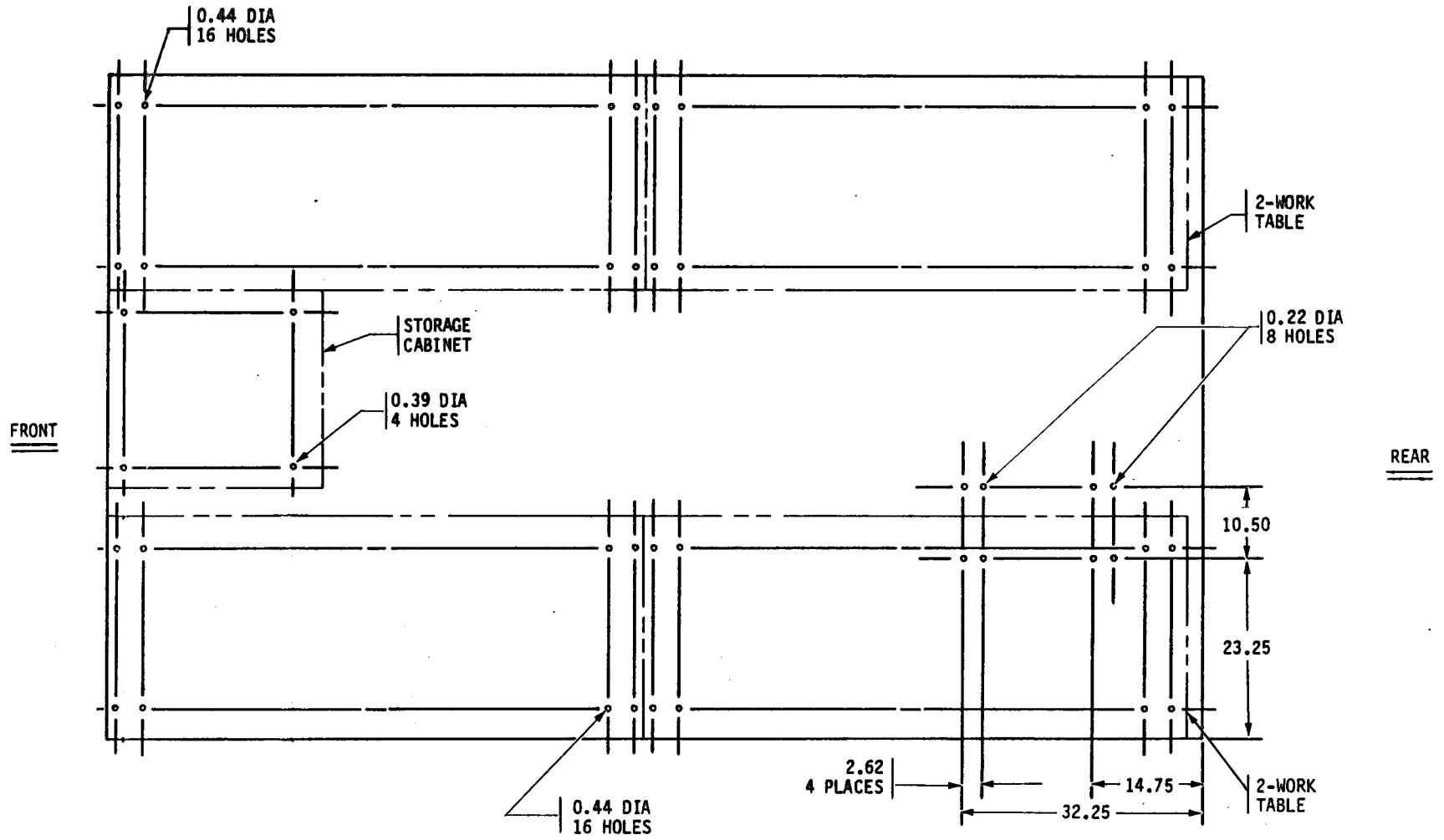
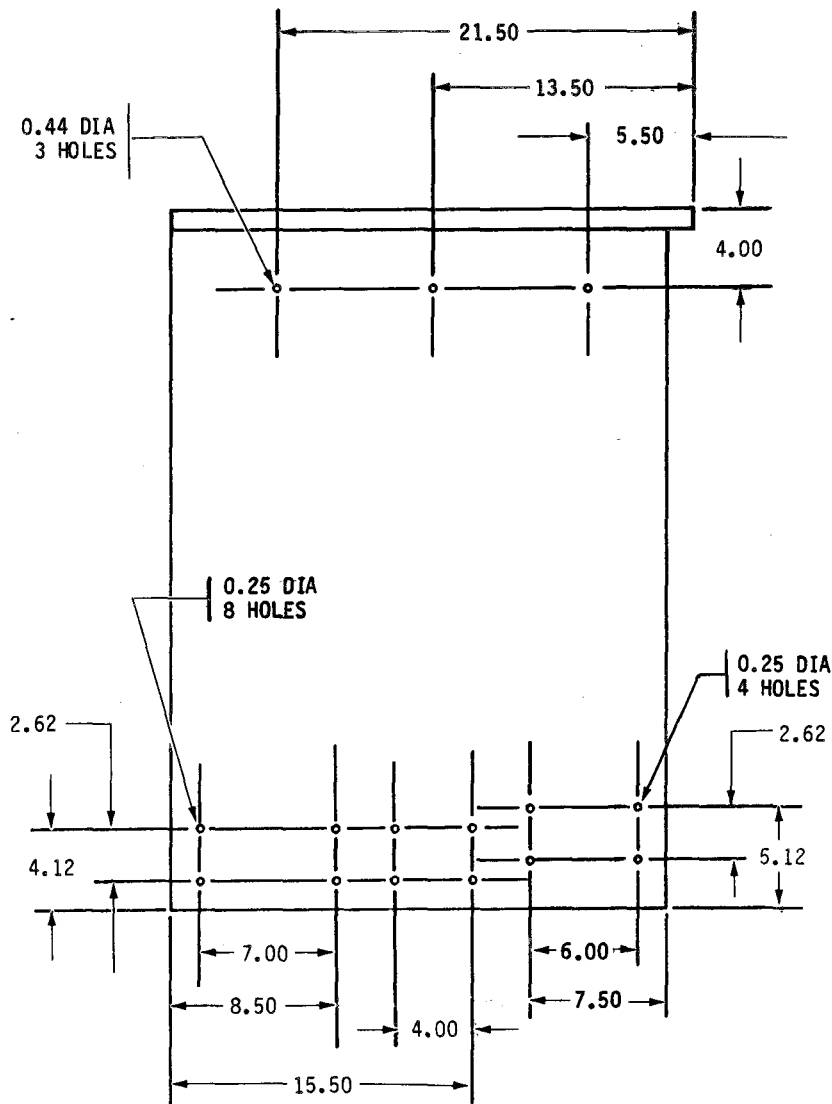

Figure 12. Hole dimensions for floor mounted equipment, unit 2, M35A2.



FRONT OF CABINET

Figure 13. Hole dimensions for blind rivet nuts and squareneck bolts, unit 2, M35A2, left side of front wall mounted cabinet.

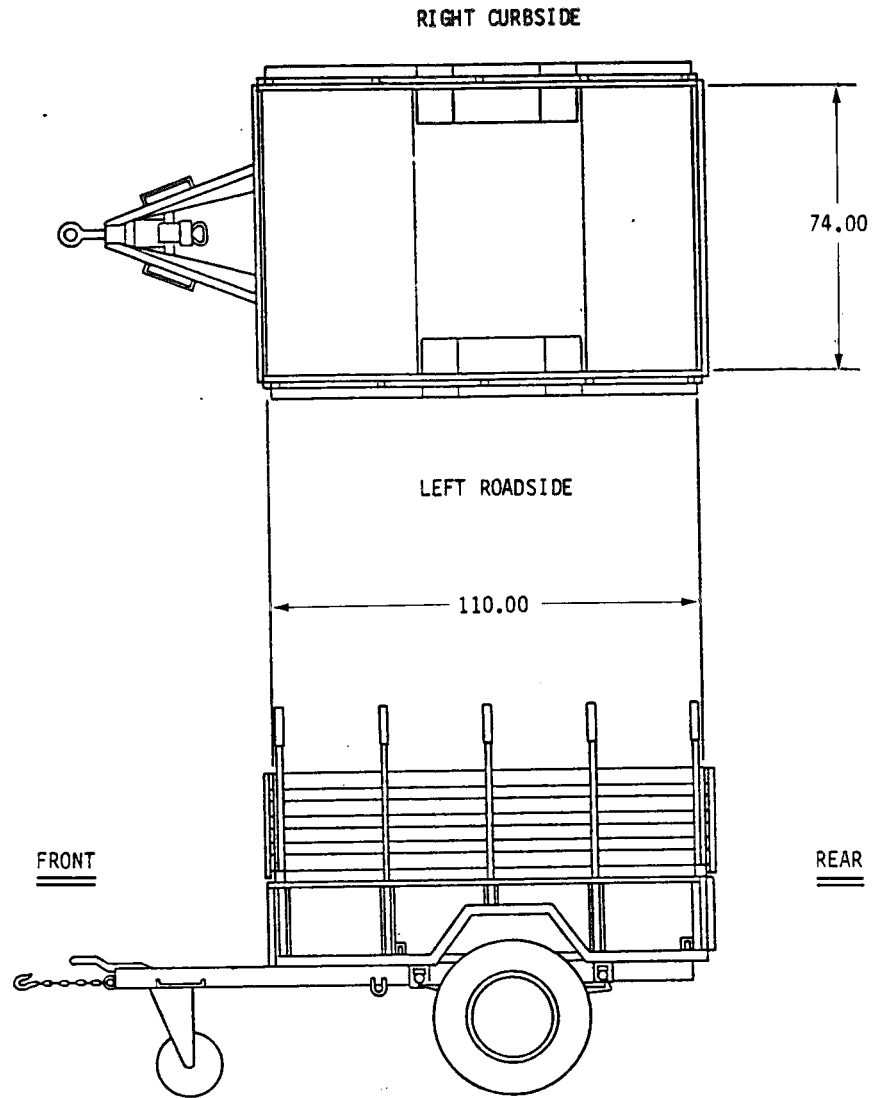

Figure 14. Cargo trailer, M105A2, unit 3.

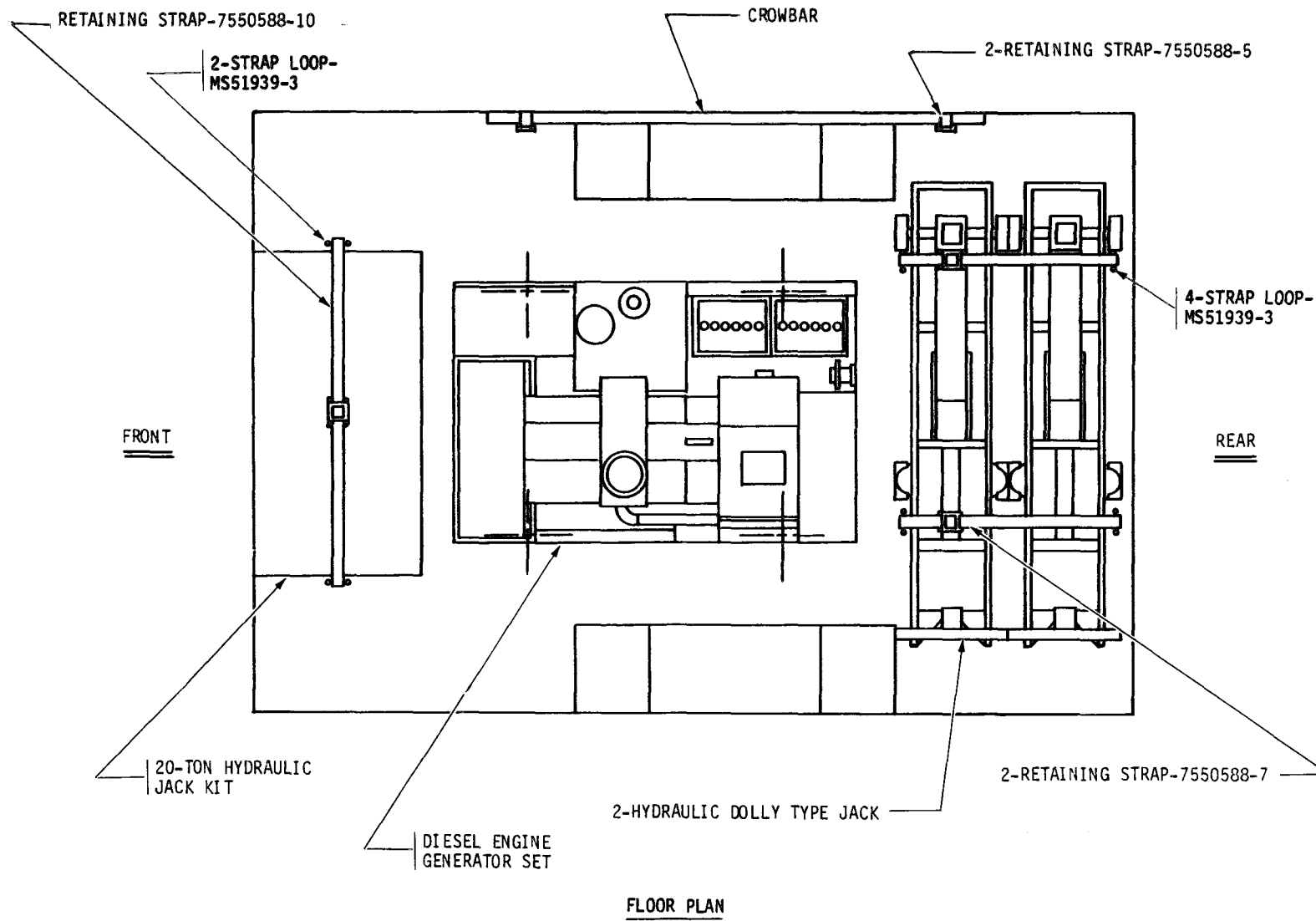

Figure 15. Components to be mounted, floor plan, unit 3, M105A2.

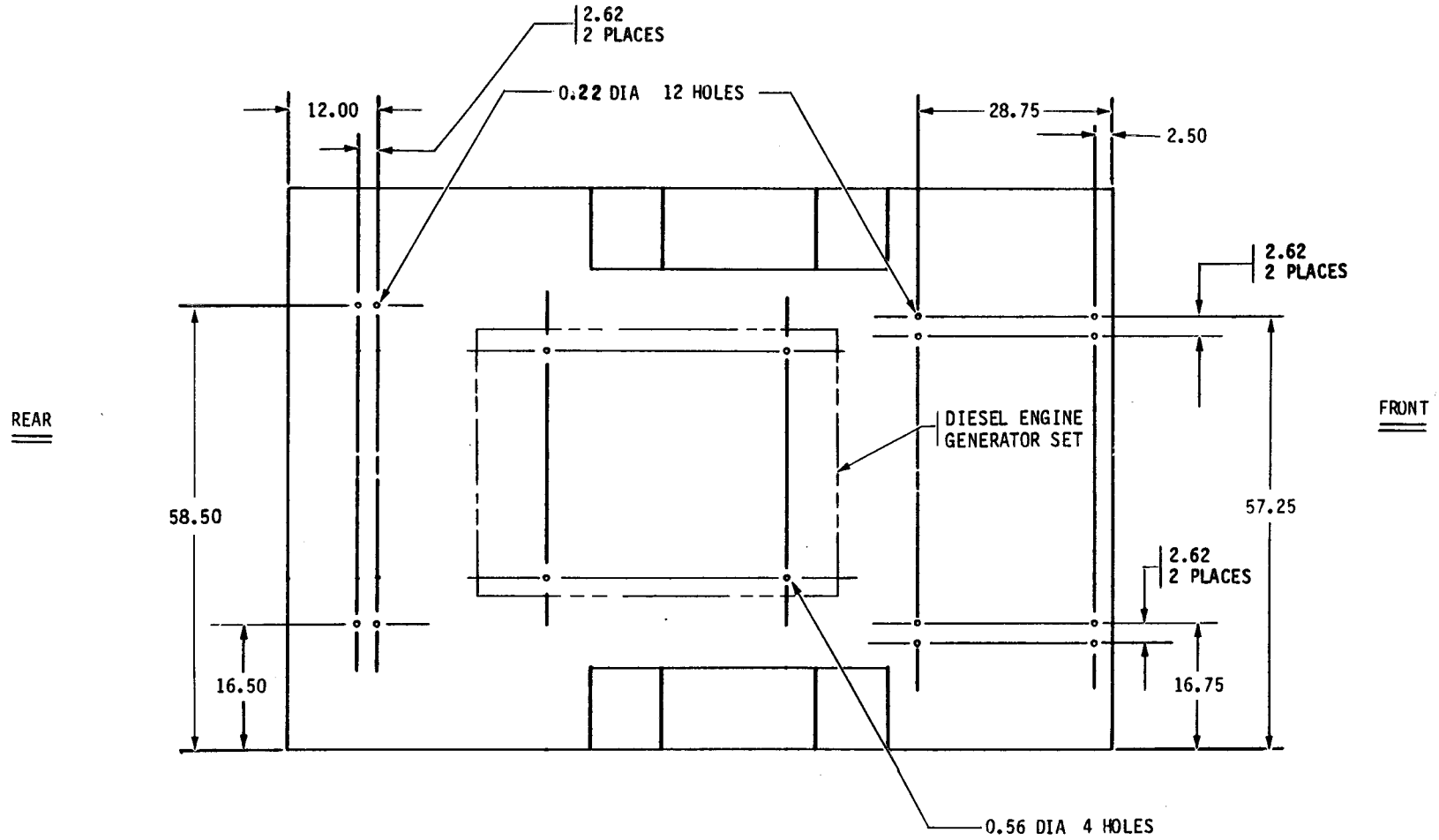

Figure 16. Hole dimensions for floor mounted equipment, unit 3, M105A2.

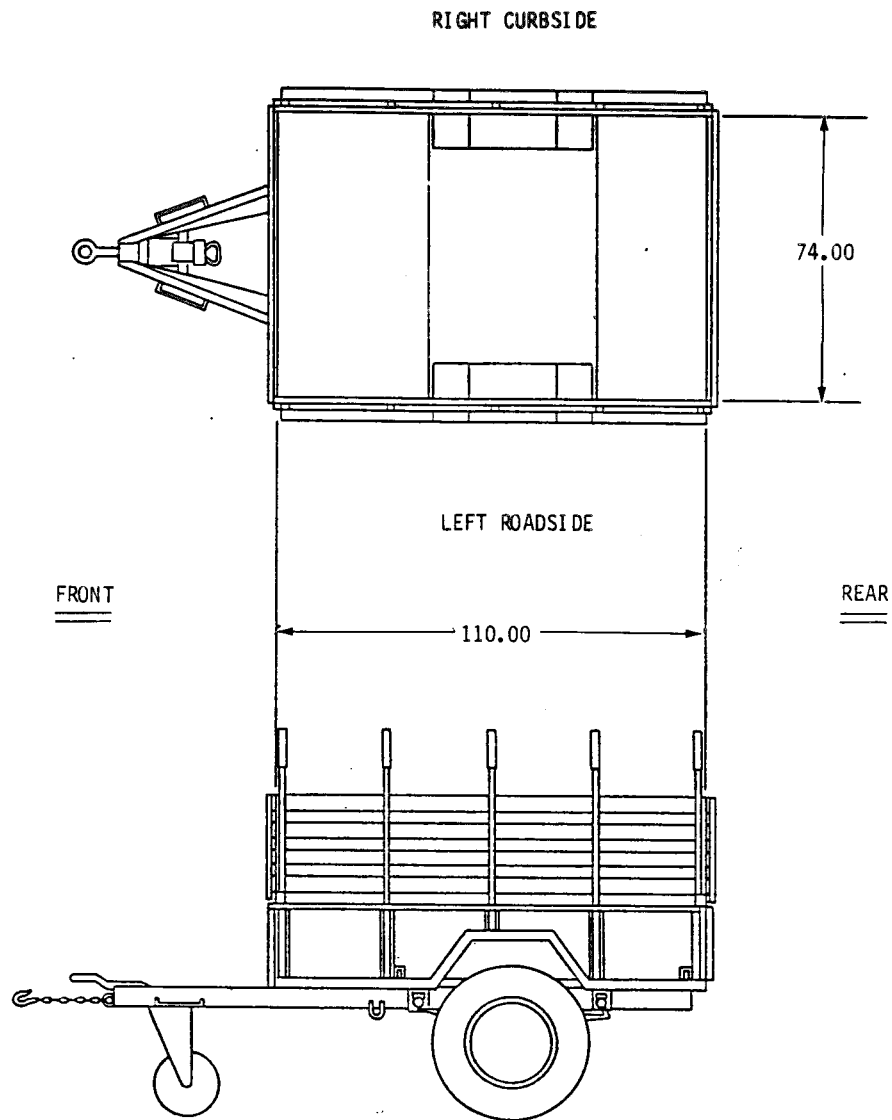

Figure 17. Cargo trailer, M105A2, unit 4.

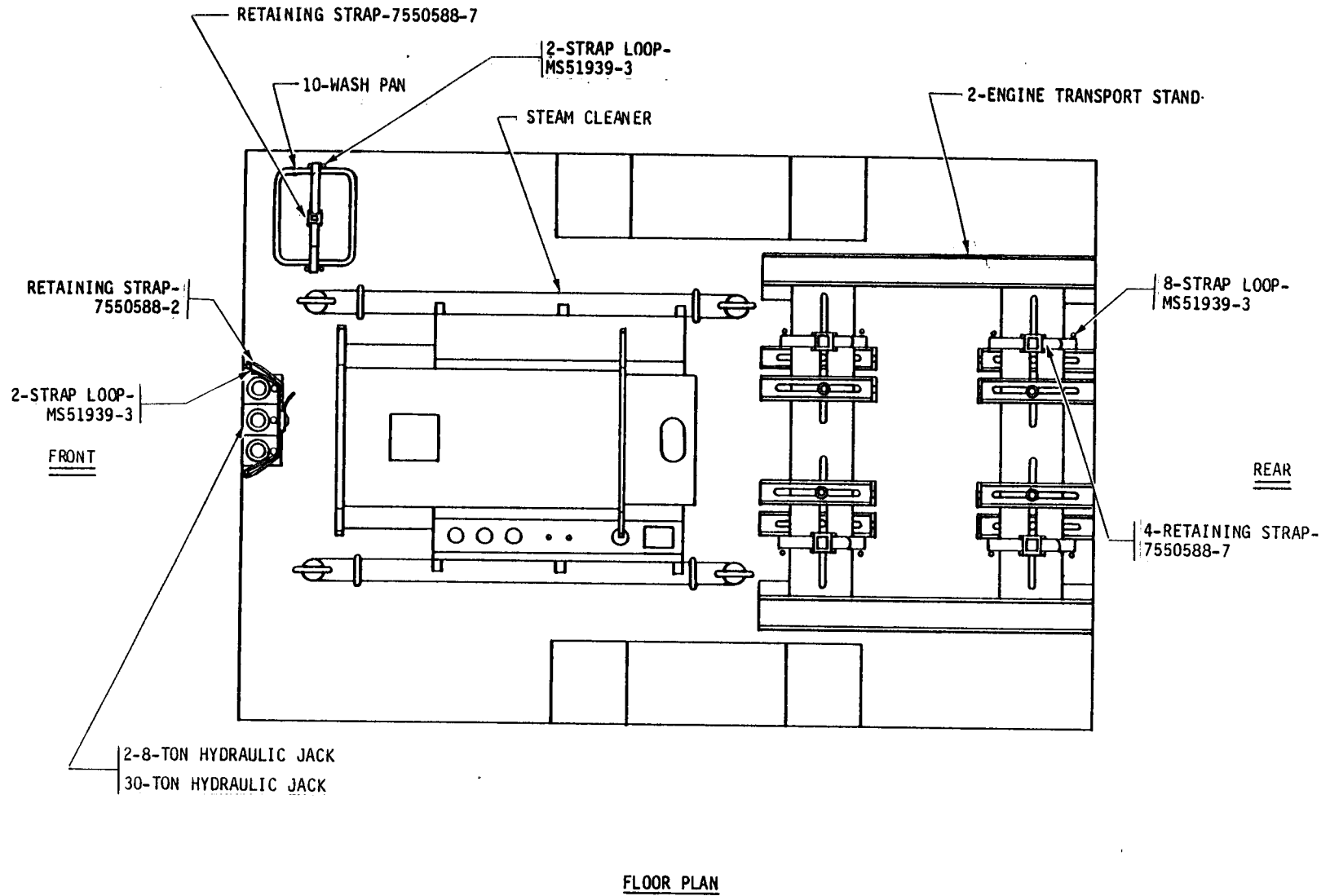

Figure 18. Components to be mounted, floor plan, unit 4, M105A2.

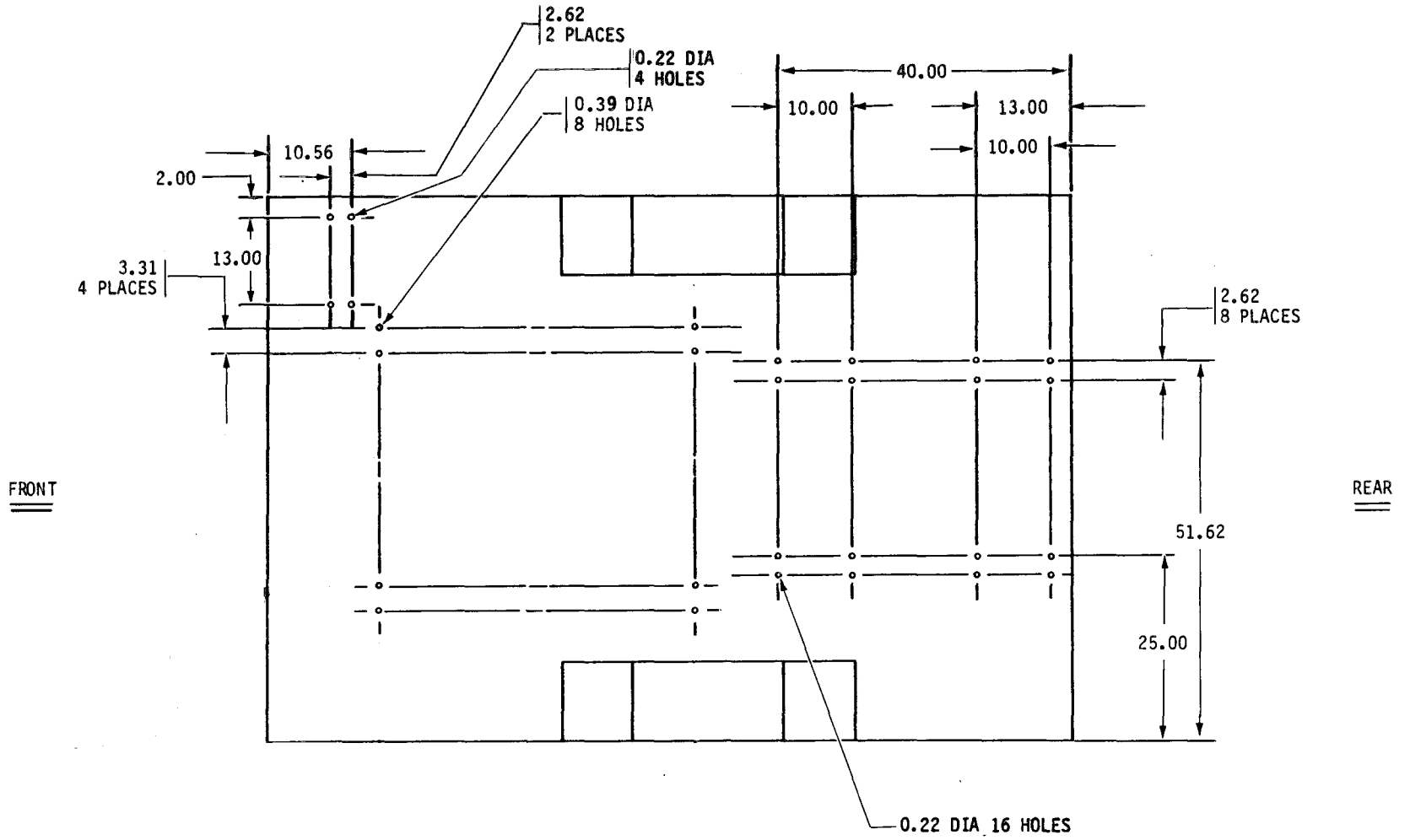

Figure 19. Hole dimensions for floor mounted equipment, floor plan, unit 4, M105A2.

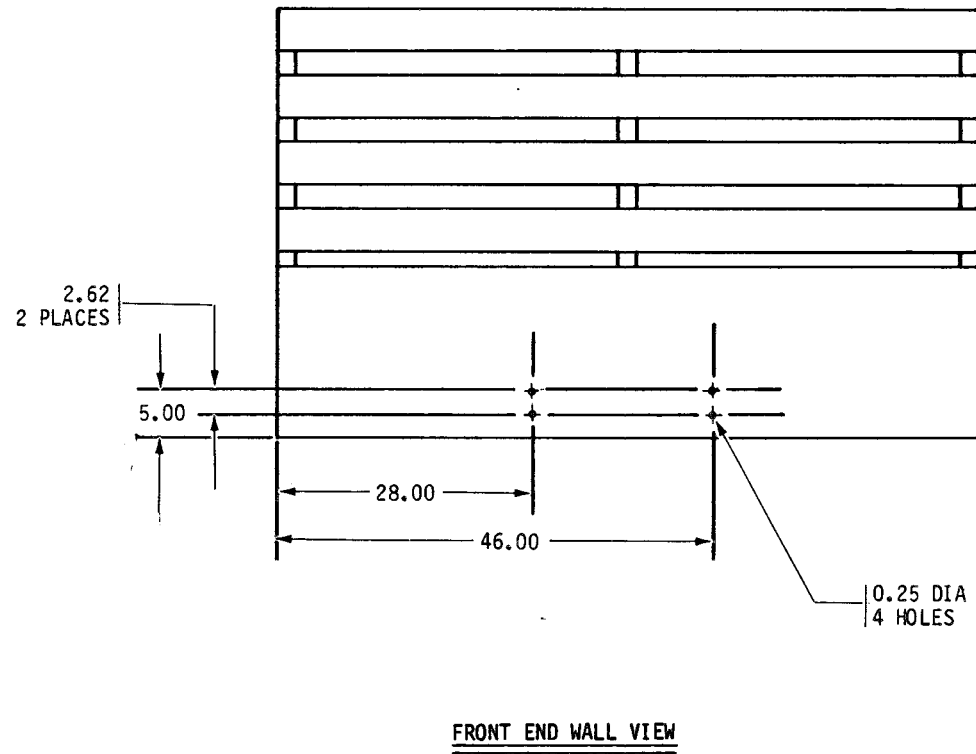

Figure 20. Hole dimensions for blind rivet nuts, unit 4, M105A2.

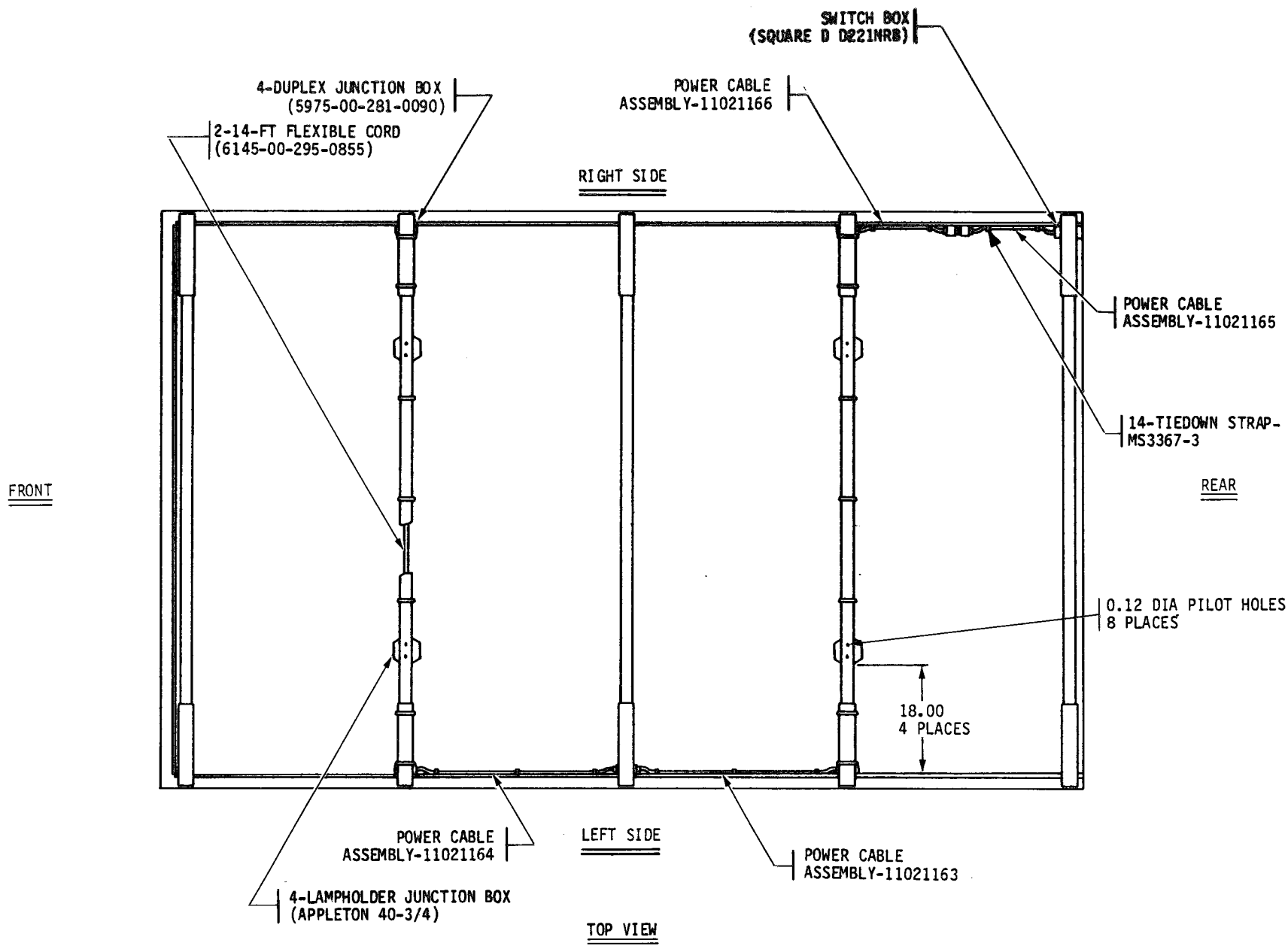

Figure 21. Electrical components to be mounted, unit 2, M35A2, top view.

TB 9-4910-746-30

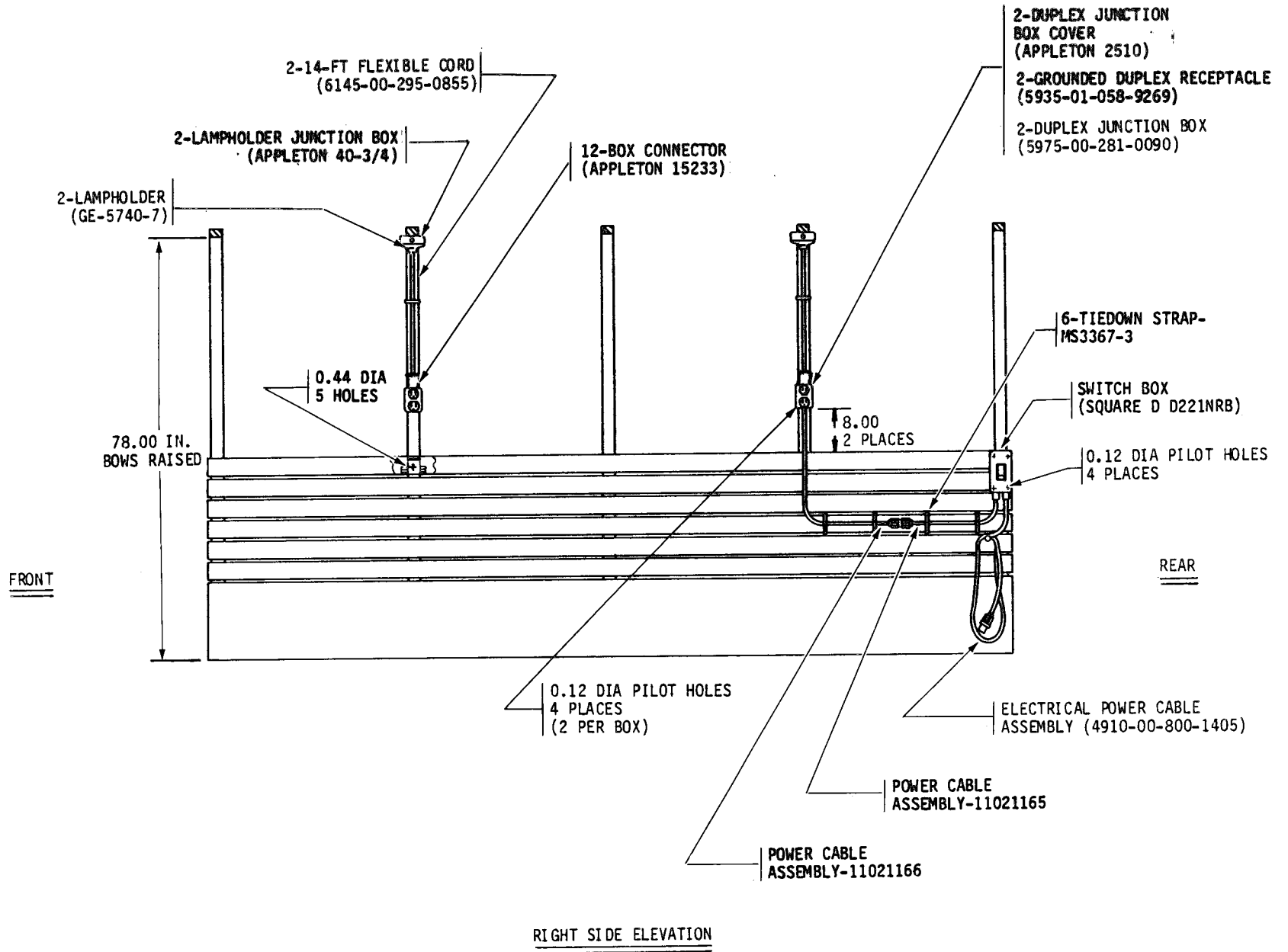

Figure 22. Electrical components to be mounted, unit 2, M35A2, right side elevation.

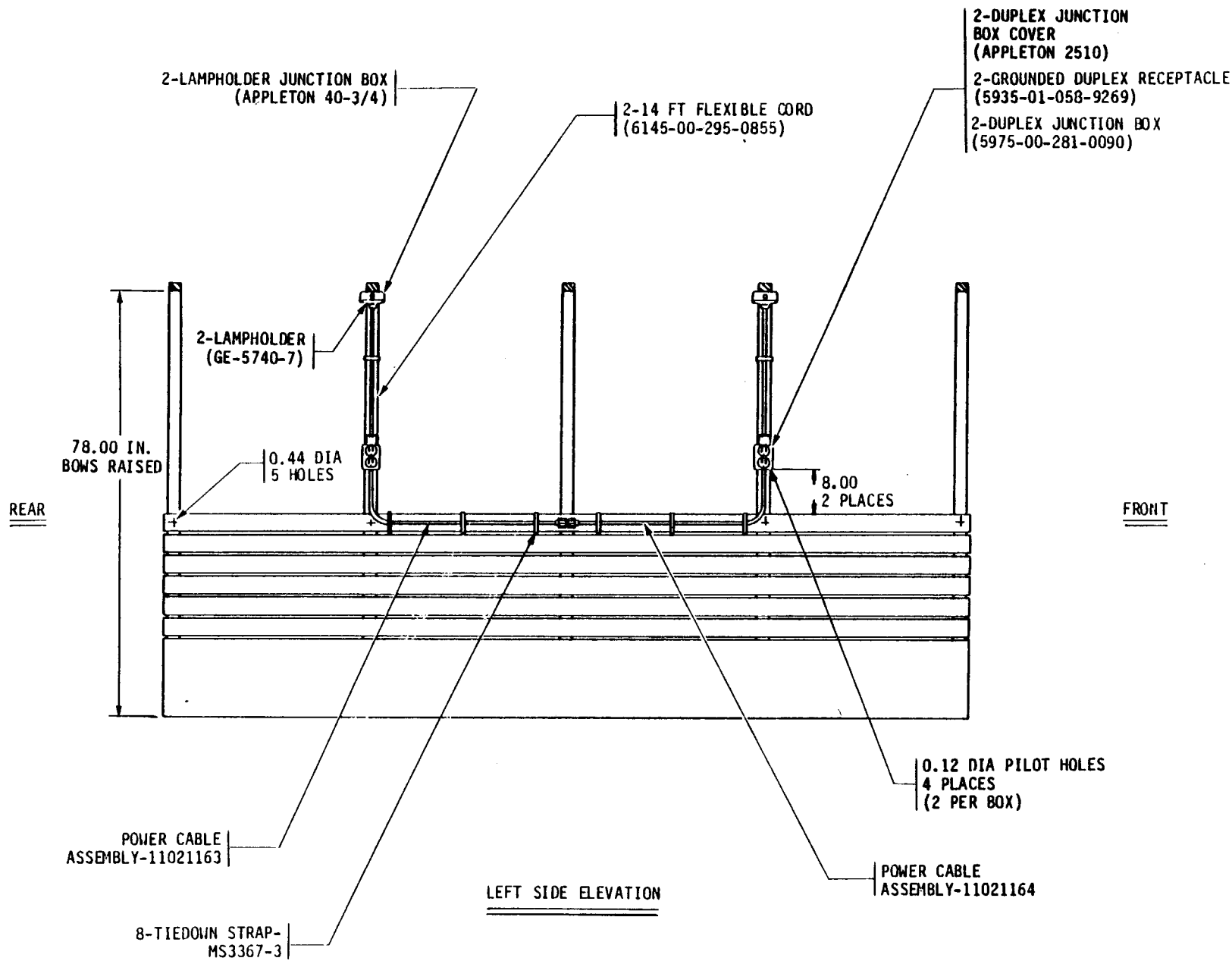

Figure 23. Dimensions for components to be mounted, unit 2, M35A2, left side elevation.

TB 9-4910-746-30

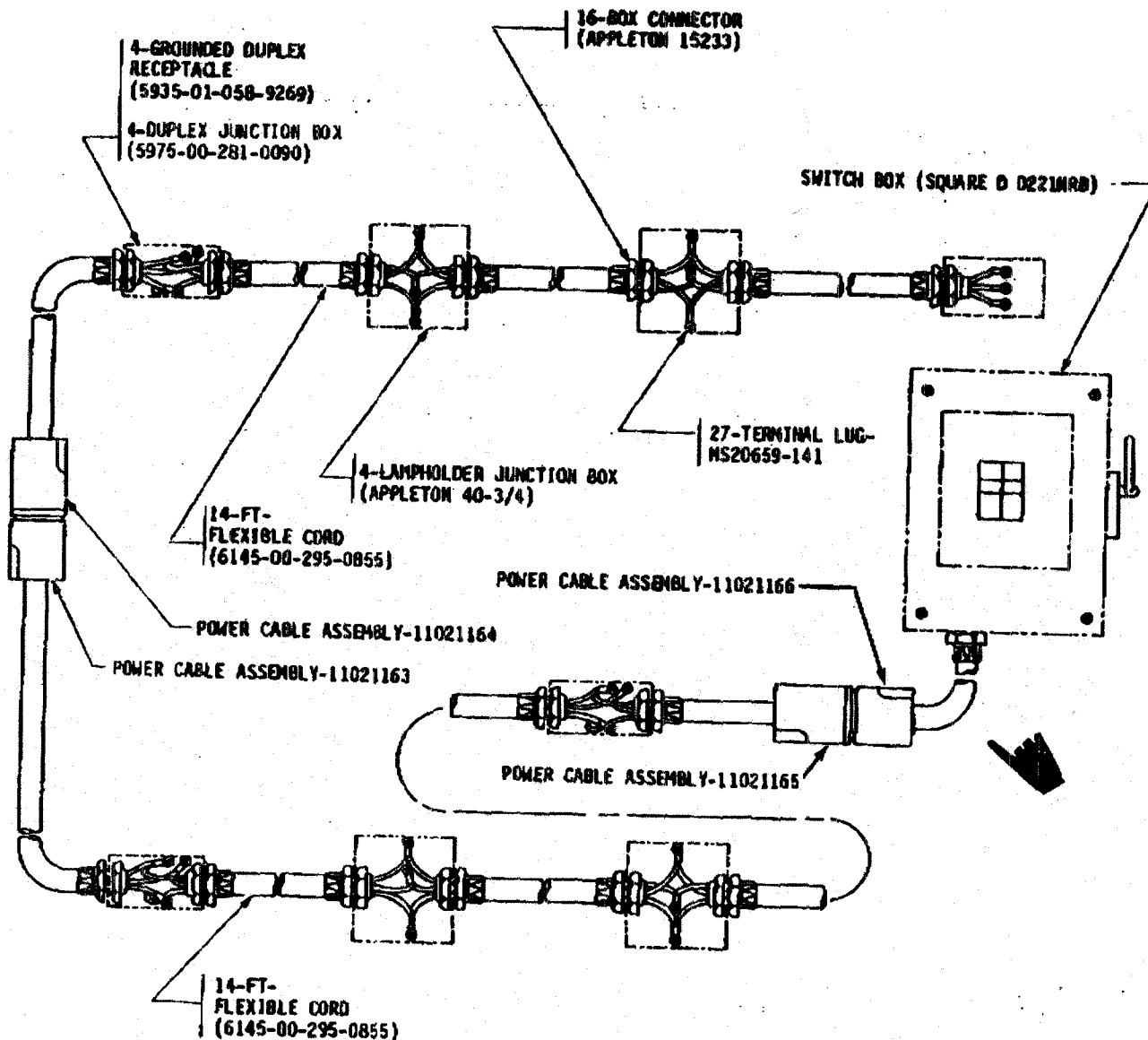

Figure 24. Electrical schematic, unit 2, M35A2.

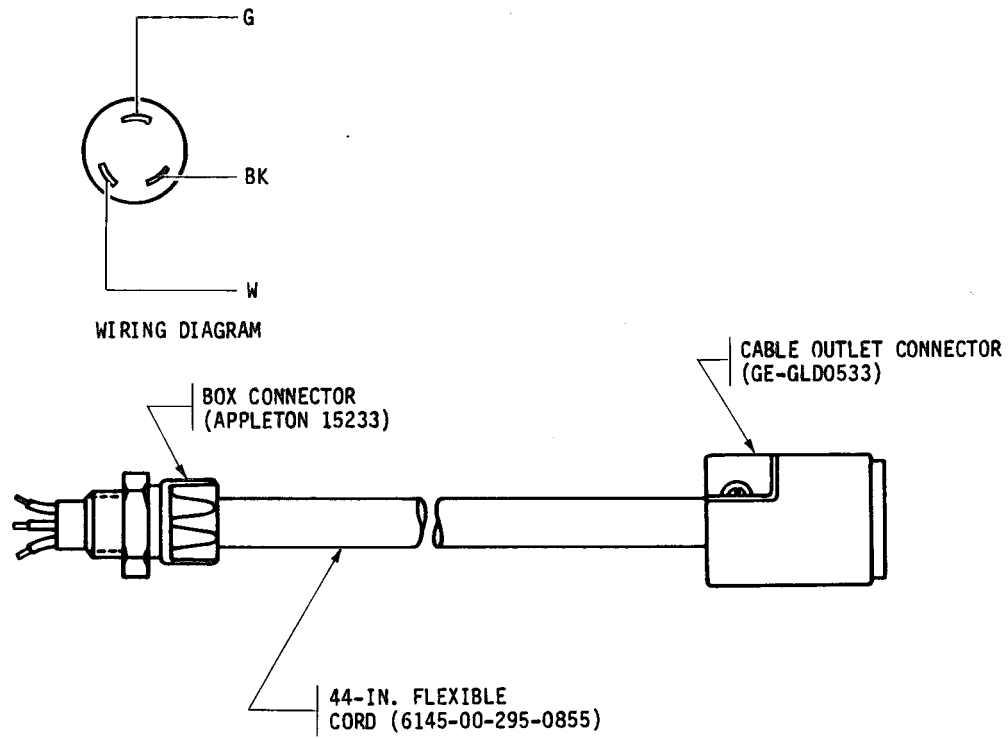

Figure 25. Power cable assembly, 11021163, unit 2, M35A2.

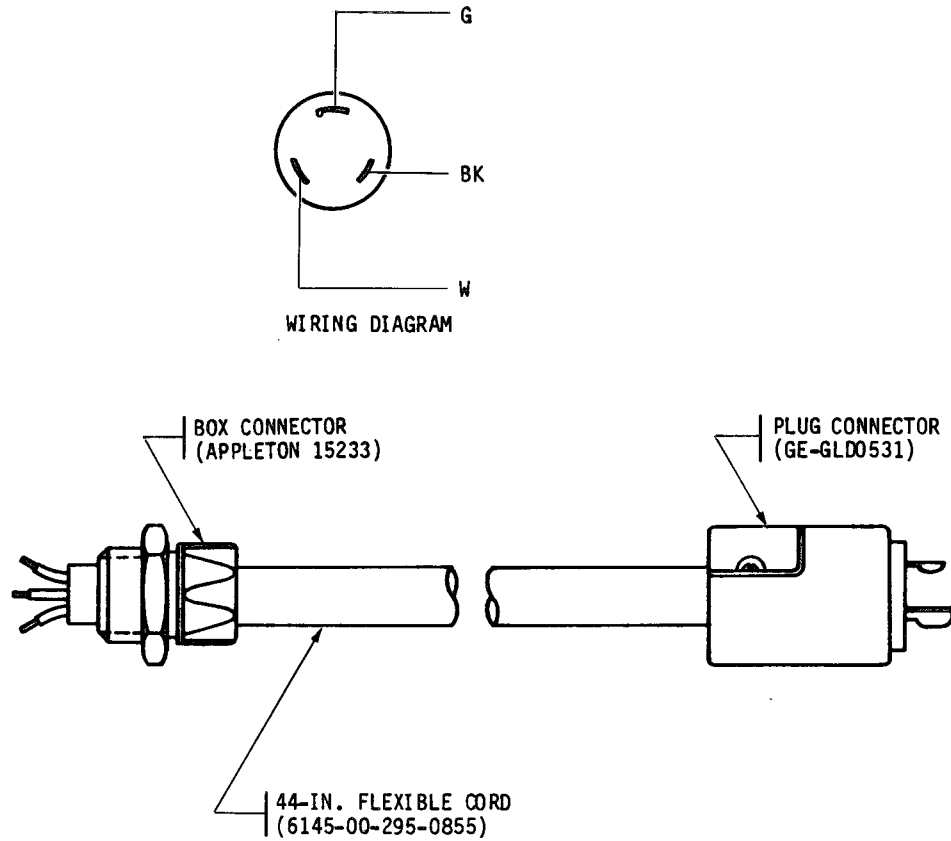

Figure 26. Power cable assembly, 11021164, unit 2, M35A2.

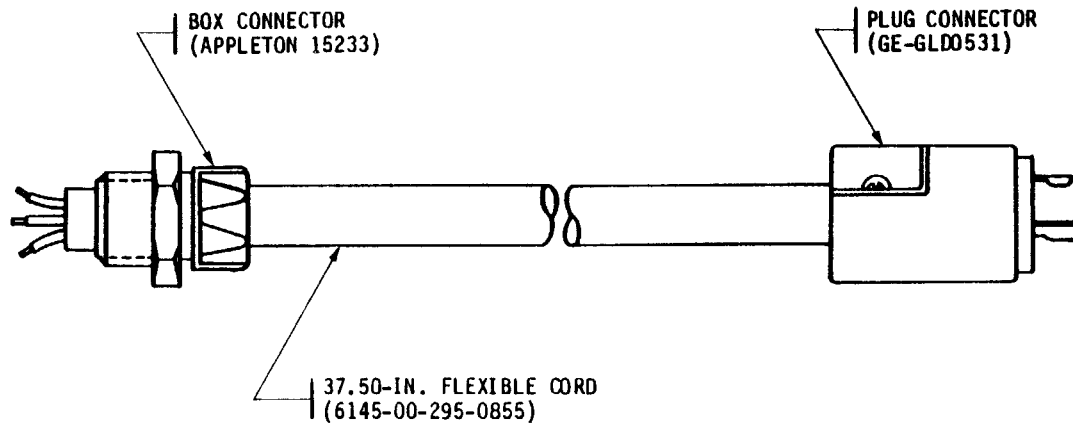
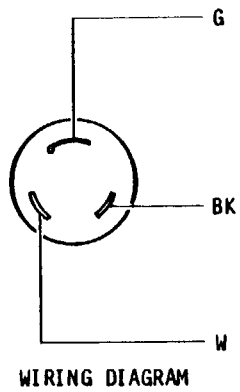

Figure 27. Power cable assembly, 11021165, unit 2, M35A2.

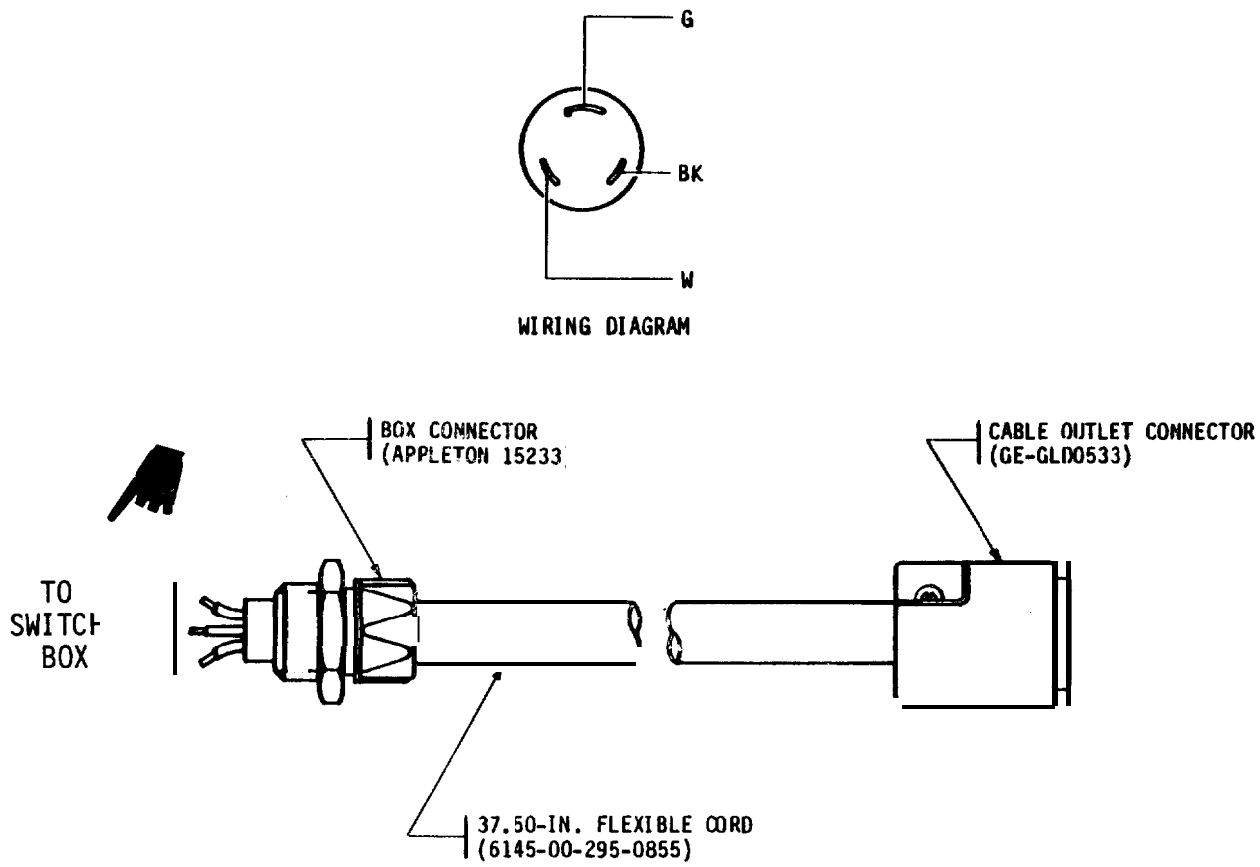

Figure 28. r cable assembly, 11021166, unit 2, M35A2.

Table 4. Standard Conversion Chart

Nomi nal si ze	Deci mal si ze	Nomi nal si ze	Deci mal si ze
1/16	0.06	35/64	0.55
5/64	0.08	9/16	0.56
3/32	0.09	37/64	0.58
7/64	0.11	19/32	0.59
1/8	0.12	39/64	0.61
9/64	0.14	5/8	0.62
5/32	0.16	41/64	0.64
11/64	0.17	21/32	0.66
3/16	0.19	43/64	0.67
13/64	0.20	11/16	0.69
7/32	0.22	45/64	0.70
15/64	0.23	23/32	0.72
1/4	0.25	47/64	0.73
17/64	0.27	3/4	0.75
9/32	0.28	49/64	0.77
19/64	0.30	25/32	0.78
5/16	0.31	51/64	0.80
21/64	0.33	13/16	0.81
11/32	0.34	53/64	0.83
23/64	0.36	27/32	0.84
3/8	0.38	55/64	0.86
25/64	0.39	7/8	0.88
13/32	0.41	57/64	0.89
27/64	0.42	29/32	0.91
7/16	0.44	59/64	0.92
29/64	0.45	15/16	0.94
15/32	0.47	61/64	0.95
31/64	0.48	31/32	0.97
1/2	0.50	63/64	0.98
33/64	0.52	1	1.00
17/32	0.53		

By Order of the Secretary of the Army:

Official:

JOHN A. WICKHAM, JR.
General, United States Army
Chief of Staff

ROBERT M. JOYCE
Major General, United States Army
The Adjutant General

Distribution:

To be distributed in accordance with DA Form 12-21, requirements for FSC Group 4910: Motor Vehicle, Repair Shop Specialized Equipment.

RECOMMENDED CHANGES TO EQUIPMENT TECHNICAL PUBLICATIONS



THEN...JOT DOWN THE DOPE ABOUT IT ON THIS FORM. CAREFULLY TEAR IT OUT, FOLD IT AND DROP IT IN THE MAIL.

SOMETHING WRONG WITH PUBLICATION

FROM: (PRINT YOUR UNIT'S COMPLETE ADDRESS)

DATE SENT

PUBLICATION NUMBER

PUBLICATION DATE

PUBLICATION TITLE

BE EXACT PIN-POINT WHERE IT IS

PAGE NO.

PARA-GRAPH

FIGURE NO.

TABLE NO.

IN THIS SPACE, TELL WHAT IS WRONG AND WHAT SHOULD BE DONE ABOUT IT.

TEAR ALONG PERFORATED LINE

PRINTED NAME, GRADE OR TITLE AND TELEPHONE NUMBER

SIGN HERE

The Metric System and Equivalents

Linear Measure

1 centimeter = 10 millimeters = .39 inch
 1 decimeter = 10 centimeters = 3.94 inches
 1 meter = 10 decimeters = 39.37 inches
 1 dekameter = 10 meters = 32.8 feet
 1 hectometer = 10 dekameters = 328.08 feet
 1 kilometer = 10 hectometers = 3,280.8 feet

Weights

1 centigram = 10 milligrams = .15 grain
 1 decigram = 10 centigrams = 1.54 grains
 1 gram = 10 decigrams = .035 ounce
 1 dekagram = 10 grams = .35 ounce
 1 hectogram = 10 dekagrams = 3.52 ounces
 1 kilogram = 10 hectograms = 2.2 pounds
 1 quintal = 100 kilograms = 220.46 pounds
 1 metric ton = 10 quintals = 1.1 short tons

Liquid Measure

1 centiliter = 10 milliliters = .34 fl. ounce
 1 deciliter = 10 centiliters = 3.38 fl. ounces
 1 liter = 10 deciliters = 33.81 fl. ounces
 1 dekaliter = 10 liters = 2.64 gallons
 1 hectoliter = 10 dekaliters = 26.42 gallons
 1 kiloliter = 10 hectoliters = 264.18 gallons

Square Measure

1 sq. centimeter = 100 sq. millimeters = .155 sq. inch
 1 sq. decimeter = 100 sq. centimeters = 15.5 sq. inches
 1 sq. meter (centare) = 100 sq. decimeters = 10.76 sq. feet
 1 sq. dekameter (are) = 100 sq. meters = 1,076.4 sq. feet
 1 sq. hectometer (hectare) = 100 sq. dekameters = 2.47 acres
 1 sq. kilometer = 100 sq. hectometers = .386 sq. mile

Cubic Measure

1 cu. centimeter = 1000 cu. millimeters = .06 cu. inch
 1 cu. decimeter = 1000 cu. centimeters = 61.02 cu. inches
 1 cu. meter = 1000 cu. decimeters = 35.31 cu. feet

Approximate Conversion Factors

To change	To	Multiply by	To change	To	Multiply by
inches	centimeters	2.540	ounce-inches	newton-meters	.007062
feet	meters	.305	centimeters	inches	.394
yards	meters	.914	meters	feet	3.280
miles	kilometers	1.609	meters	yards	1.094
square inches	square centimeters	6.451	kilometers	miles	.621
square feet	square meters	.093	square centimeters	square inches	.155
square yards	square meters	.836	square meters	square feet	10.764
square miles	square kilometers	2.590	square meters	square yards	1.196
acres	square hectometers	.405	square kilometers	square miles	.386
cubic feet	cubic meters	.028	square hectometers	acres	2.471
cubic yards	cubic meters	.765	cubic meters	cubic feet	35.315
fluid ounces	milliliters	29.573	cubic meters	cubic yards	1.308
pints	liters	.473	milliliters	fluid ounces	.034
quarts	liters	.946	liters	pints	2.113
gallons	liters	3.785	liters	quarts	1.057
ounces	grams	28.349	liters	gallons	.264
pounds	kilograms	.454	grams	ounces	.035
short tons	metric tons	.907	kilograms	pounds	2.205
pound-feet	newton-meters	1.356	metric tons	short tons	1.102
pound-inches	newton-meters	.11296			

Temperature (Exact)

°F Fahrenheit temperature 5/9 (after subtracting 32) Celsius temperature °C

PIN: 056299-001