

TM 10-5411-231-13&P

TECHNICAL MANUAL

OPERATOR'S, UNIT, AND DIRECT SUPPORT MAINTENANCE
MANUAL
INCLUDING REPAIR PARTS AND SPECIAL TOOLS LIST (RPSTL)
FOR

CARGO BED COVER (CBC) HMMWV, TYPE I

NSN 5411-01-467-3243 (CAMOUFLAGE)
NSN 5411-01-479-1928 (SAND)

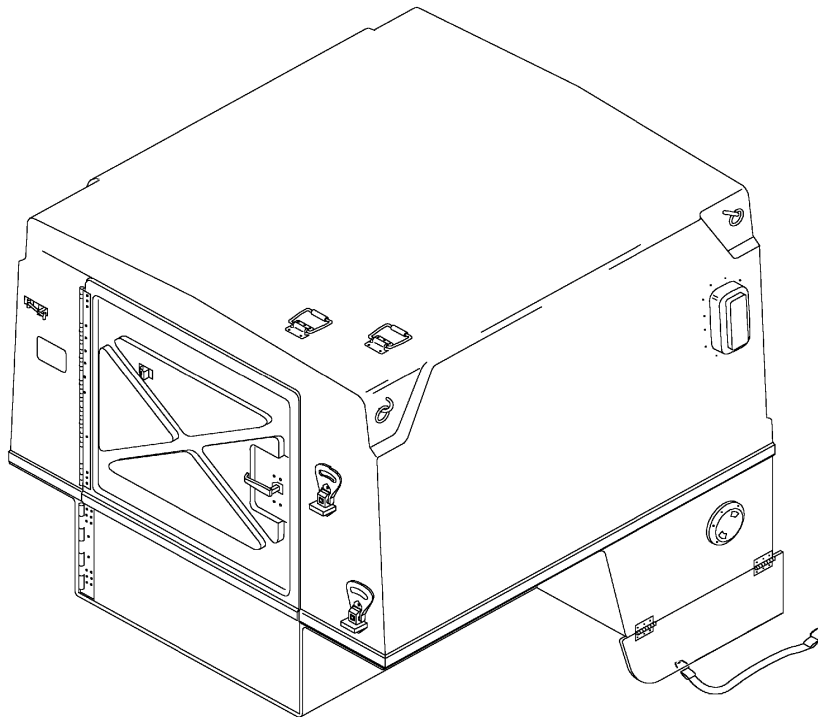

DISTRIBUTION STATEMENT A - Approved for public release; Distribution is unlimited.

HEADQUARTERS, DEPARTMENT OF THE ARMY

1 August 2001

WARNING SUMMARY

The following warnings are recommended precautions that must be understood and applied during operation and maintenance of the CBC covered in this manual. Should situations arise that are not covered in these warnings, the commanding officer or other authority shall issue orders necessary to cover the situation.

WARNING

Safety shoes, gloves and protective eyewear are required to protect personnel when lifting and installing the CBC.

WARNING

Use only approved lifting devices when installing and removing the CBC. The lifting device (1 ton or more) should be within the annual inspection period and the CBC weight should be within the lifting device weight capacity.

WARNING

Personnel should not stand under the CBC, on top of the CBC, inside the CBC, or on the vehicle while it is being hoisted.

WARNING

The CBC is not a shelter system and is not to be transported with personnel or sentry dogs inside. Personnel can only work inside the CBC when the unit is deployed and the ventilators and doors are open.

WARNING

Do not remain inside the CBC with door closed. There is a suffocation hazard. A person inside the CBC can exit quickly (even with the external latch padlocked) by operating the inside handle to open the door.

WARNING

Safe loading of the CBC requires two personnel. Stay clear of the unit while lifting, as serious injury can result if unit swings or drops and hits personnel.

WARNING

All chemical materials used in this process are flammable and toxic. Use only in well ventilated areas. Avoid prolonged or repeated breathing of vapors or contact with skin. Make repairs to fiberglass parts in a well ventilated area. Always wear breathing mask, gloves and eye protection.

WARNING

Some environments, including desert and high temperature areas, could cause the interior of the CBC to reach high temperatures, causing injury or death to personnel.

WARNING

The use of power sanders and grinders is prohibited. Inhalation of concentrated amounts of CARC paint dust by personnel can cause injury.

WARNING

Possible damage to an open or improperly latched door could result from strong wind gusts or from heavy loading and can cause injury to personnel standing nearby.

CHANGE
NO. 1

HEADQUARTERS,
DEPARTMENT OF THE ARMY
WASHINGTON, D.C., 31 AUGUST 2005

TECHNICAL MANUAL
OPERATOR'S, UNIT, AND DIRECT SUPPORT MAINTENANCE
MANUAL
INCLUDING REPAIR PARTS AND SPECIAL TOOLS LIST (RPSTL)
FOR
CARGO BED COVER (CBC) HMMWV, TYPE I
NSN 5411-01-467-3243 (CAMOUFLAGE)
NSN 5411-01-479-1928 (SAND)

DISTRIBUTION STATEMENT A: - Approved for public release; distribution is unlimited.

TM 10-5411-231-13&P, dated 1 August 2001, is changed as follows:

1. File this sheet in the front of the manual for reference.
2. This change implements the Army Maintenance Transformation and changes the Maintenance Allocation Chart (MAC) to Support Field and Sustainment Maintenance.
3. New or updated text is indicated by a vertical bar in the outer margin.
4. Added illustrations are indicated by a vertical bar adjacent to the figure number. Changed illustrations are indicated by a miniature hand adjacent to the updated area and a vertical bar adjacent to the figure number.
5. Remove old pages and insert new pages as indicated below.

Remove Pages

A/(B Blank)
Electronic 2028 Instructions/Blank
Sample 2028/Envelope
2028/Envelope

Remove Pages

A/(B Blank)
Electronic 2028 Instructions/Blank
Sample 2028 – Front/Back
2028 Front/Back
2028 Front/Back
2028 Front/Back

6. Replace the following work packages with their revised version.

Work Package Number

WP 0023 00

By Order of the Secretary of the Army:
C1

PETER J. SCHOOMAKER
General, United States Army
Chief of Staff

Official:

SANDRA R. RILEY
Administrative Assistant to the
Secretary of the Army
0523004

DISTRIBUTION:

To be distributed in accordance with initial distribution number (IDN) 256681 requirements for TM 10-5411-231-13&P.

INSERT LATEST CHANGED PAGES/WORK PACKAGES. DESTROY SUPERSEDED DATA.

LIST OF EFFECTIVE PAGES/WORK PACKAGES

NOTE: The portion of the text affected by the update is indicated by a vertical line in the outer margins of the page. Updates to illustrations are indicated by miniature pointing hands or vertical lines in the outer margins of the page in the area of the illustration changed. Zero in the "Change No." column indicates an original page or work package.

Dates of issue for the original manual and changed pages/work packages are:

Original 1 August 2001
 Change 1 31 August 2005

TOTAL NUMBER OF PAGES FOR FRONT AND REAR MATTER IS 20. THE TOTAL NUMBER OF WORK PACKAGES IS 28 CONSISTING OF THE FOLLOWING:

Page/WP No.	Change No.	Page/WP No.	Change No.
Front Cover	0	WP 0013 00 (2 pgs)	0
Warning	0	WP 0014 00 (2 pgs)	0
i – iii/(iv blank)	0	WP 0015 00 (2 pgs)	0
v/(vi blank)	0	WP 0016 00 (2 pgs)	0
Chp 1 title page (2 pgs)	0	WP 0017 00 (2 pgs)	0
WP 0001 00 (2 pgs)	0	WP 0018 00 (2 pgs)	0
WP 0002 00 (4 pgs)	0	WP 0019 00 (2 pgs)	0
WP 0003 00 (2 pgs)	0	WP 0020 00 (2 pgs)	0
WP 0004 00 (2 pgs)	0	Chp 6 title page (2 pgs)	0
Chp 2 title page (2 pgs)	0	WP 0021 00 (6 pgs)	0
WP 0005 00 (2 pgs)	0	Chp 7 title page (2 pgs)	0
WP 0006 00 (4 pgs)	0	WP 0022 00 (2 pgs)	0
WP 0007 00 (2 pgs)	0	WP 0023 00 (6 pgs)	1
Chp 3 title page (2 pgs)	0	WP 0024 00 (8 pgs)	0
WP 0008 00 (2 pgs)	0	WP 0025 00 (4 pgs)	0
Chp 4 title page (2 pgs)	0	WP 0026 00 (4 pgs)	0
WP 0009 00 (4 pgs)	0	WP 0027 00 (4 pgs)	0
Chp 5 title page (2 pgs)	0	WP 0028 00 (2 pgs)	0
WP 0010 00 (4 pgs)	0	Glossary-1 – Glossary-2	0
WP 0011 00 (2 pgs)	0	Index-1– Index-2	0
WP 0012 00 (2 pgs)	0	Back Cover	0

TECHNICAL MANUAL
OPERATOR'S, UNIT, AND DIRECT SUPPORT MAINTENANCE
MANUAL
INCLUDING REPAIR PARTS AND SPECIAL TOOLS LIST (RPSTL)
FOR

CARGO BED COVER (CBC) HMMWV, TYPE I

NSN 5411-01-467-3243 (CAMOUFLAGE)
NSN 5411-01-479-1928 (SAND)

REPORTING ERRORS AND RECOMMENDING IMPROVEMENTS

You can help improve this manual. If you find any mistakes or if you know of a way to improve the procedures, please let us know. Mail your letter together with DA Form 2028 (Recommended Changes to Publications and Blank Forms), located in the back of this manual, directly to: Commander, U.S. Army Soldier Biological and Chemical Command, ATTN: AMSSB-RIM-E(N) Kansas Street, Natick, MA 01760-5052. You may also send in your recommended changes via electronic mail directly to "AMSSB-RIM-E@natick.army.mil". A reply will be furnished to you. Instructions for sending an electronic 2028 may be found in this manual immediately preceding the hard copy 2028.

DISTRIBUTION STATEMENT A - Approved for public release; Distribution is unlimited.

TABLE OF CONTENTS

	WP Sequence No
WARNING SUMMARY	
HOW TO USE THIS MANUAL	
CHAPTER 1	
INTRODUCTION	
General Information	0001 00
Equipment Description	0002 00
Theory of Operation	0003 00
Common Tools and Equipment	0004 00
Repair Parts, Special Tools, TMDE and Support Equipment	0004 00
CHAPTER 2	
OPERATOR'S INSTRUCTIONS	
CONTROLS AND INDICATORS	
General.....	0005 00

HEADQUARTERS, DEPARTMENT OF THE ARMY

1 August 2001

OPERATION UNDER USUAL CONDITIONS	
Operating Procedures	0006 00
Decals and Instruction Plates	0006 00
Preparation for Movement	0006 00
OPERATION UNDER UNUSUAL CONDITIONS	
Emergency Procedures.....	0007 00
Unusual Environmental Conditions	0007 00
CHAPTER 3	
OPERATOR'S TROUBLESHOOTING PROCEDURES	
General	0008 00
CHAPTER 4	
OPERATOR'S MAINTENANCE INSTRUCTIONS	
General	0009 00
Inspection	0009 00
Lubrication Service Intervals	0009 00
Cleaning	0009 00
Preventive Maintenance Checks and Services (PMCS)	0009 00
CHAPTER 5	
UNIT MAINTENANCE INSTRUCTIONS	
SERVICE UPON RECEIPT	
Unpacking	0010 00
Checking Unpacked Equipment	0010 00
Assembly and Preparation for Use.....	0010 00
Installation	0010 00
Storage and Shipment	0010 00
Upper Door Assembly	0011 00
Door Holder	0012 00
Lower Door Assembly	0013 00
Cab Access Door	0014 00
Access Plate	0015 00
Storage Access Panel Assembly	0016 00
2-Way Ventilator	0017 00
Folding Step	0018 00
Chest Handle	0019 00
24-Inch Ladder	0020 00
CHAPTER 6	
DIRECT SUPPORT MAINTENANCE INSTRUCTIONS	
CBC SHELL ASSEMBLY	
General	0021 00
Minor Repair	0021 00
Major Damage Repair	0021 00
Lifting Ring Repair	0021 00
Interior Mounting Instructions	0021 00

CHAPTER 7

SUPPORTING INFORMATION

References	0022 00
Maintenance Allocation Chart (MAC)	0023 00
Repair Parts and Special Tools List (RPSTL)	0024 00
Components of End Item (COEI) List	0027 00
Expendable and Durable Items List	0028 00

GLOSSARY	GLOSSARY 1
----------------	------------

ALPHABETICAL INDEX	INDEX-1
--------------------------	---------

LIST OF ILLUSTRATIONS

Figure No.	Title	WP Sequence No
1	Group 00 CBC	0025 00
2	Group 01 CBC	0026 00

LIST OF TABLES

Table No.	Title	WP Sequence No
0002 00-1	Equipment Data	0002 00
0002 00-2	Lifting Requirements	0002 00
0005 00-1	CBC Controls	0005 00
0008 00-1	Troubleshooting Procedures	0008 00
0009 00-1	Preventive Maintenance Checks and Services for CBC HMMWV, Type I	0009 00
0021 00-1	CBC Repair Kit P/N 104276-1 (Shelf Life Items)	0021 00
0021 00-2	CBC Repair Kit P/N 104276-2 (Indefinite Shelf Life Items)	0021 00
0023 00-1	MAC for Cargo Bed Cover (CBC) HMMWV, Type I	0023 00
0023 00-2	Tools and Test Equipment for Cargo Bed Cover (CBC) HMMWV, Type I	0023 00
0023 00-3	Remarks for Cargo Bed Cover (CBC) HMMWV, Type I	0023 00
0027 00-1	Components of End Item (COEI) List	0027 00
0027 00-2	Basic Issue Items List	0027 00
0028 00-1	Expendable and Durable Items List	0028 00

HOW TO USE THIS MANUAL

This manual contains General information, Operating Instructions, Operator's Preventive Maintenance Checks and Services (PMCS), Troubleshooting, and Maintenance/Repair instructions for the Cargo Bed Cover (CBC) HMMWV, Type I.

Chapter 1 contains introductory information on the CBC and its associated equipment as well as Theory of Operation. Chapter 2 includes operator instructions under usual and unusual conditions. Chapter 3 contents include operator troubleshooting procedures. Chapter 4 contains operator maintenance instructions, PMCS and service procedures. Chapter 5 contains unit maintenance instructions. Chapter 6 contains minor and major repair procedures. Chapter 7 contains references and other supporting information. Chapter 7 also includes the Maintenance Allocation Chart and the Repair Parts and Special Tools List (RPSTL) which identifies those parts or tools which are unique to the operation and maintenance of this equipment.

Figures. Illustrations in this manual other than the RPSTL are not numbered. They are immediately following the paragraph, which contains their callouts.

Manual Organization and Page Numbering System. The manual is divided into six major chapters that detail the topics mentioned above. The work package is numbered sequentially starting at page 1 and has its own page numbering scheme. A page number such as 0010 00-1/2 blank means that page 1 contains information but page 2 of the work package has been intentionally left blank.

Finding Information. The manual has a master Table of Contents as well as separate chapter Tables of Content. The master Table of Contents on pages i through iii permits the reader to find information in the manual quickly. The reader should start here first when looking for a specific topic. The master Table of Contents lists the topics contained within a chapter and where it can be found. Refer to the Table of Contents at the beginning of each chapter for a detailed listing of each topic and the work package sequence number.

An Alphabetical Index can be found at the back of the manual, and lists specific topics of the work package.

A Glossary of Terms is provided to explain terms and words which are unique to this equipment.

CHAPTER 1
INTRODUCTION
FOR
CARGO BED COVER (CBC) HMMWV, TYPE I

TM 10-5411-231-13&P

CARGO BED COVER (CBC) HMMWV, TYPE I
TABLE OF CONTENTS

Subject	Page
SCOPE	0001 00-1
MAINTENANCE FORMS RECORDS AND REPORTS.....	0001 00-1
REPORTING EQUIPMENT IMPROVEMENT RECOMMENDATIONS (EIRs)	0001 00-1
CORROSION PREVENTION AND CONTROL (CPC)	0001 00-1
DESTRUCTION OF ARMY MATERIEL TO PREVENT ENEMY USE	0001 00-1
PREPARATION FOR STORAGE AND SHIPMENT.....	0001 00-2
WARRANTY INFORMATION	0001 00-2
NOMENCLATURE CROSS-REFERENCE LIST	0001 00-2
LIST OF ABBREVIATIONS	0001 00-2
SAFETY, CARE AND HANDLING	0001 00-2
EQUIPMENT CHARACTERISTICS, CAPABILITIES AND FEATURES	0002 00-1
LOCATION AND DESCRIPTION OF MAJOR COMPONENTS.....	0002 00-2
DIFFERENCES BETWEEN MODELS	0002 00-4
EQUIPMENT DATA	0002 00-4
LIFTING REQUIREMENTS	0002 00-4
EQUIPMENT CONFIGURATION	0002 00-4
THEORY OF OPERATION	0003 00-1
COMMON TOOLS AND EQUIPMENT	0004 00-1
REPAIR PARTS, SPECIAL TOOLS, TMDE AND SUPPORT EQUIPMENT	0004 00-2

SCOPE

This technical manual is for use by personnel responsible for the operation, maintenance, checks and services and preventive and corrective maintenance for the Cargo Bed Cover (CBC) HMMWV, Type I. The CBC is designed to protect, store, and secure equipment, tools and pilferable supplies while being transported on tactical wheeled vehicles.

Type of Manual: Operator's, Unit, and Direct Support Maintenance.

Equipment Name and Part Number: Cargo Bed Cover (CBC) HMMWV, Type I; Part Number 103984.

Purpose of Equipment: The primary mission of the CBC is to provide a rigid enclosure designed to secure and environmentally protect items while not diminishing the transportation requirements of the host vehicle. The cover serves as a vented, weather-tight, lockable alternative to the "bow and canvas" type cover currently used on a number of light and medium tactical vehicles and trailers.

MAINTENANCE FORMS RECORDS AND REPORTS.

Department of the Army forms and procedures used for CBC maintenance will be those prescribed by DA PAM 738-750, Functional Users Manual for The Army Maintenance Management System (TAMMS).

REPORTING EQUIPMENT IMPROVEMENT RECOMMENDATIONS (EIRs).

If your CBC needs improvement, let us know. Send us an EIR. You, the user, are the only one who can tell us what you don't like about the equipment. Let us know why you don't like the design or performance. Put it on an SF368 Product Quality Deficiency Report. Mail it to: Commander, U.S. Army Soldier and Biological Chemical Command. ATTN: AMSSB-RIM-E(N), Kansas St. Natick MA 01760. We will send a reply to your report.

CORROSION PREVENTION AND CONTROL (CPC).

Corrosion Prevention and Control (CPC) of Army materiel is a continuing concern. It is important that any corrosion problems with this item be reported so that the problem can be corrected and improvements can be made to prevent the problem in future items.

While corrosion is typically associated with rusting of metals, it can also include deterioration of other materials, such as rubber or plastic. Unusual cracking, softening, swelling or breaking of these materials may be a corrosion problem.

If a corrosion problem is identified, it can be reported using SF368, Product Quality Deficiency Report. Use of key words such as "corrosion", "rust", "deterioration" or "cracking" will ensure that the information is identified as a CPC problem. This form should be submitted to the address specified in DA Pam 738-750.

DESTRUCTION OF ARMY MATERIEL TO PREVENT ENEMY USE.

For procedures to destroy this equipment to prevent its use by the enemy, refer to TM 750-244-3, Procedures for Destruction of Army Equipment to Prevent Enemy Use (Mobility Equipment Command).

PREPARATION FOR STORAGE AND SHIPMENT.

Refer to Work Package 0010 00 for procedures to prepare the CBC for storage and shipment.

WARRANTY INFORMATION.

The manufacturer shall not be liable for any special or consequential damages, including normal wear and tear or misuse. Warranty for the CBC will be in effect for a period of ten (10) years from the date of sale.

NOMENCLATURE CROSS-REFERENCE LIST.

Common Name	Official Name
CBC	Cargo Bed Cover

LIST OF ABBREVIATIONS.

AP	Attaching Parts	MOS	Military Occupational Specialty
A/R	As Required	MTOE	Modified Table of Organization and Equipment
BII	Basic Issue Items	NHA	Next Higher Assembly
BOI	Basis of Issue	NIIN	National Item Identification Number
CAGEC	Commercial and Government Entity Code	NSN	National Stock Number
CARC	Chemical Agent Resistant Coating	PMCS	Preventive Maintenance Checks and Services
CBC	Cargo Bed Cover	P/N	Part Number
COEI	Components of End Item	REF	Reference
COML	Commercial	RPSTL	Repair Parts and Special Tools List
CPC	Corrosion Prevention Control	SMR	Source, Maintenance and Recoverability
CTA	Common Table of Allowance	TMDE	Test Measurement and Diagnostic Equipment
EIR	Equipment Improvement Recommendation	UOC	Usable on Code
EMP	Electromagnetic Pulse	UUT	Unit Under Test
FGC	Functional Group Code		
HCI	Hardness Critical Item		
HMMWV	High Mobility Multi-Purpose Wheeled Vehicle		
MAC	Maintenance Allocation Chart		

SAFETY, CARE AND HANDLING.

Always pay attention to Warnings, Cautions and Notes appearing throughout the manual. They will appear prior to applicable procedures. Ensure you read and understand their content to prevent serious injury to yourself and others, or damage to equipment.

- Safety shoes, gloves and eyewear are required to protect personnel when installing and lifting the CBC.
- The CBC lifting device should be within the annual inspection period and the CBC weight should be within the lifting device weight capacity of 1 ton minimum.
- No one should be under the suspended CBC, on the vehicle or inside the CBC when the CBC is being loaded.

- The CBC is not a shelter system. Personnel may not ride or sleep in the back of the vehicle when the CBC is used.
- Only approved lifting devices should be used to install and remove the CBC.
- Personnel should not stand under the CBC while it is being hoisted.

EQUIPMENT CHARACTERISTICS, CAPABILITIES AND FEATURES.

The CBC is an alternative to bow and canvas covers and a replacement to the locally constructed built-up non-standard plywood, steel, or fiberglass shelters currently used in the field for storage of mission equipment. Unlike the "bow and canvas" the CBC cannot transport personnel, but troops can work inside the CBC once the CBC is deployed.

Characteristics

Capabilities

Molded structure
Internal access from vehicle cab
Upper and lower aft access doors
Can be installed by MOS non-specific personnel
Waterproofed/non water intrusive
Fiberglass reinforced plastic
2-Way ventilators for fresh air ventilation
External transportable by helicopter

2-Way ventilators
Inside override door lock
Blackout capable
Oversized doors capable of entering and exiting while carrying equipment or supplies
Standard military lift/tie-down points for transport by helicopter sling when installed on vehicle only
Ports provided to permit pass through of power and signal lines

LOCATION AND DESCRIPTION OF MAJOR COMPONENTS.

The major components of the CBC are identified in Major Components illustration, and described in the following paragraphs.

Upper and Lower Door Assemblies - Two separate door assemblies, upper and lower, are located on the aft end of the CBC. The doors can be interlocked with each other by engaging the handle of the upper door. This then allows both doors to be closed and opened together at the same time. The lower door can be separately locked in place by operating the latch on the inside. Note that the upper door must be open to accomplish this. An override of the latch allows the doors to be opened from the inside in case of emergency.

Cab Access Door - This door is located at the front of the CBC and consists of two halves, which slide on a track. Two web handles are provided, one on each half, for opening and closing the door to gain access to the HMMWV cab.

2-Way Ventilator - A 2-way ventilator is located on road side and curb side of the CBC towards the forward end. The ventilators are operated from the inside.

Folding Step - There are two folding steps located on the aft (external) end of the CBC. The steps are spring-loaded and extend and retract when operated by hand. The steps provide access for climbing on top of the CBC. Under normal conditions, the steps are retracted.

Ladder - The ladder is a 24" folding step ladder located inside the CBC. It is secured with an adjustable ratchet strap assembly that is molded on the CBC.

Chest Handle - Two chest handles are provided on top of the CBC near the aft left side. They are used for gripping when climbing on top of the CBC by using the folding steps.

Access Plate - The two access plates, one on each side of the CBC, are round covers that are screwed onto the cable boots attached to the CBC. When loosened, the access plate is supported by a lanyard which is bolted from inside onto the CBC. When the access cover is open, electrical or signal cables can be pushed through the cable boot opening for equipment used inside the CBC.

Storage Access Panel - The two storage access panels, one on each side of the CBC, provide for storage space on the HMMWV. It comprises a footman's loop and hook and a tie-down rubber, which fastens onto the vehicle to hold the panel in place.

Door Lock - The door lock can be operated from outside or inside the CBC even if the doors are locked from outside. This is an override feature. In addition, the upper door can be latched with the lower door to provide a single function operation.

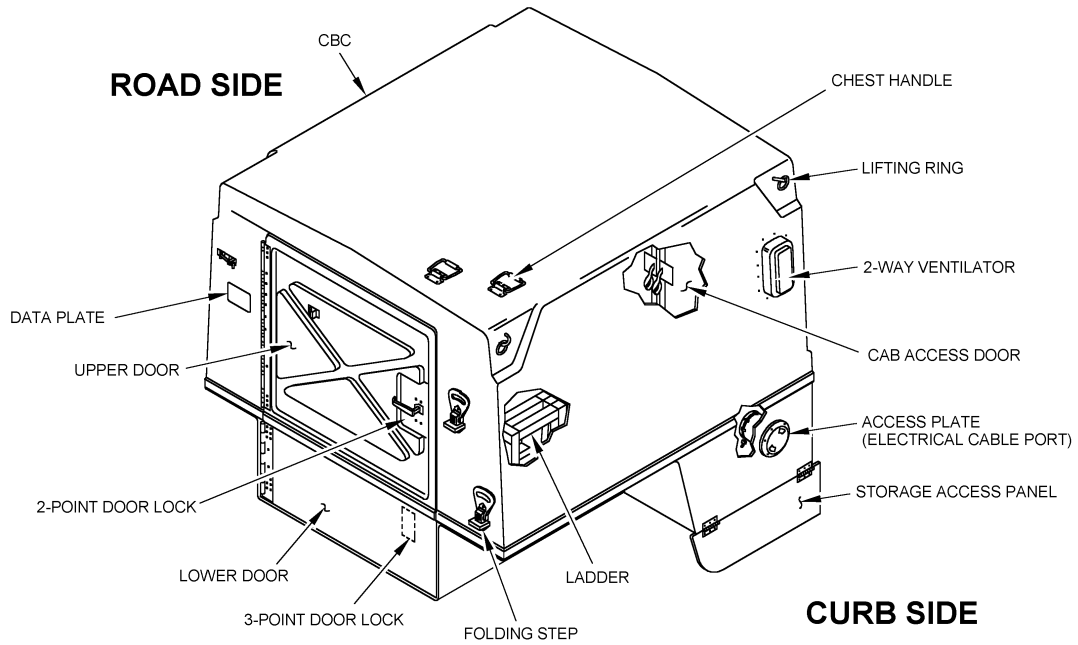

Major Components

DIFFERENCES BETWEEN MODELS

There is only one model CBC for the HMMWV, therefore, "Differences Between Models" does not apply.

EQUIPMENT DATA

Table 0002 00-1 lists the dimensions of the CBC.

CBC	Table 0002 00-1. Equipment Data		WEIGHT
	DIMENSIONS (INCHES)		
	INTERNAL	EXTERNAL	450 lbs
HEIGHT	62.5	63.5	
WIDTH	78.0	83.0	
LENGTH	80.0	83.3	
USABLE FLOOR SPACE		44 Square Feet	
DRIVING SPEED LIMIT		55 Miles Per Hour	

LIFTING REQUIREMENTS

Four lifting rings are provided, one on each side corner of the CBC, and located near the top. To lift the CBC, cables from an approved overhead lifting device are attached to the four lifting rings. See CBC LIFT ONLY stenciled on the shell. See Table 0002 00-2 for lifting requirements.

Table 0002 00-2. Lifting Requirements	
Type of Equipment	Lifting Capacity
Wrecker or crane	1 ton minimum

EQUIPMENT CONFIGURATION

The CBC is a single, molded unit which is installed by lifting it onto the vehicle and bolting it down.

THEORY OF OPERATION

The Cargo Bed Cover (CBC) HMMWV, Type I unit is designed to be mounted on the HMMWV for purposes of carrying and storing equipment for use in the field. The CBC is suitable for worldwide transportation and storage environments, including helicopter airlift when mounted on the HMMWV. It is waterproof, vented, CARC painted and secure. CBCs are painted in either sand color or in a camouflage pattern. The CBC shell features include a non-skid interior floor and exterior roof, equipment mounting provisions on three walls and the roof panel. The shell is composite fiberglass, which makes it resistant to the harshest of environments for the life of the CBC. All attaching hardware is corrosion-resistant. A CBC installation kit containing the required hardware and instructions for mounting is furnished with each CBC. The CBC is mounted to the HMMWV using six holes in the bed with no modification to the HMMWV whatsoever.

The CBC has two doors, an upper and a lower door, located at the aft end to gain access to the unit. The doors can be latched together to operate as a single door or operate separately. An override lock on the inside of upper door allows personnel to exit in case of an emergency. Access from the HMMWV to the CBC can also be obtained by way of sliding cab access doors, located at the forward end of the CBC.

Additional features of the CBC are as follows:

- Two 2-way ventilators for air circulation.
- Two access plates, one each side, when unscrewed allow cables to be pushed through the cable boot opening for connecting with equipment inside the CBC. When unscrewed, the access plate hangs to the outside supported by a lanyard.
- Storage access panels, one on each side, when closed, provide storage space for storing tools or equipment.
- A tie-down rubber strap fastens the storage access panel assembly to the HMMWV.
- A 24" ladder is stored inside the CBC and held in place by a ratchet strap assembly. It is used for climbing into the CBC.
- Two folding steps, located at the aft end, when extended, provide access to the roof of the CBC. The steps are spring-loaded.
- Two chest handles are located on the roof to grab onto when climbing the steps.
- For lifting the CBC, lifting rings are attached on each corner near the top.

TM 10-5411-231-13&P

CARGO BED COVER (CBC) HMMWV, TYPE I
COMMON TOOLS AND EQUIPMENT

0004 00

COMMON TOOLS AND EQUIPMENT

For authorized common tools and equipment, refer to the Modified Table of Organization and Equipment (MTOE), CTA 50-970, Expendable/Durable Items (Except: Medical, Class V, Repair Parts, and Heraldic Items), or CTA 8-100, Army Medical Department Expendable/Durable Items, as applicable to your unit. Also refer to General Mechanics Tool Kit 5160-00-177-7033 and Hand Blind Riveter, NSN 5129-00-017-2849.

TM 10-5411-231-13&P

CARGO BED COVER (CBC) HMMWV, TYPE I

0004 00

REPAIR PARTS, SPECIAL TOOLS, TMDE AND SUPPORT EQUIPMENT

REPAIR PARTS, SPECIAL TOOLS, TMDE AND SUPPORT EQUIPMENT

Repair parts are listed and illustrated in Work Packages 0025 00 and 0026 00 of this manual.

The CBC requires no special tools, Test Measurement and Diagnostic Equipment (TMDE) or special Support Equipment to assemble or disassemble before, during or after maintenance checks and services.

CHAPTER 2

OPERATOR'S INSTRUCTIONS
FOR
CARGO BED COVER (CBC) HMMWV, TYPE I

TM 10-5411-231-13&P

CARGO BED COVER (CBC) HMMWV, TYPE I
TABLE OF CONTENTS

Subject	Page
CONTROLS AND INDICATORS	
GENERAL	0005 00-1
OPERATION UNDER USUAL CONDITIONS	0006 00-1
OPERATING PROCEDURES	0006 00-1
OPERATION OF UPPER AND LOWER DOORS	0006 00-1
OPERATION OF CAB ACCESS DOOR	0006 00-1
OPERATION OF 2-WAY VENTILATORS	0006 00-1
OPERATION OF FOLDING STEPS	0006 00-1
DECALS AND INSTRUCTION PLATES	0006 00-2
PREPARATION FOR MOVEMENT	0006 00-3
OPERATION UNDER UNUSUAL CONDITIONS	0007 00-1
EMERGENCY PROCEDURES.....	0007 00-1
UNUSUAL ENVIRONMENTAL CONDITIONS	0007 00-2
ICE	0007 00-2
RAIN, WIND AND SAND STORM	0007 00-2

GENERAL

This paragraph contains illustrations that show the location of each control on the CBC.

NOTE

There are no indicators on the CBC.

Find numbers on the illustrations are keyed to the Table 0005 00-1 listing which contains the name and function of each control . Table 1 describes the controls for the Upper Door Assembly (1), Lower Door Assembly (2), 2-Way Ventilator (3), Folding Step (4), Cab Access Door (5), and Access Plate (6).

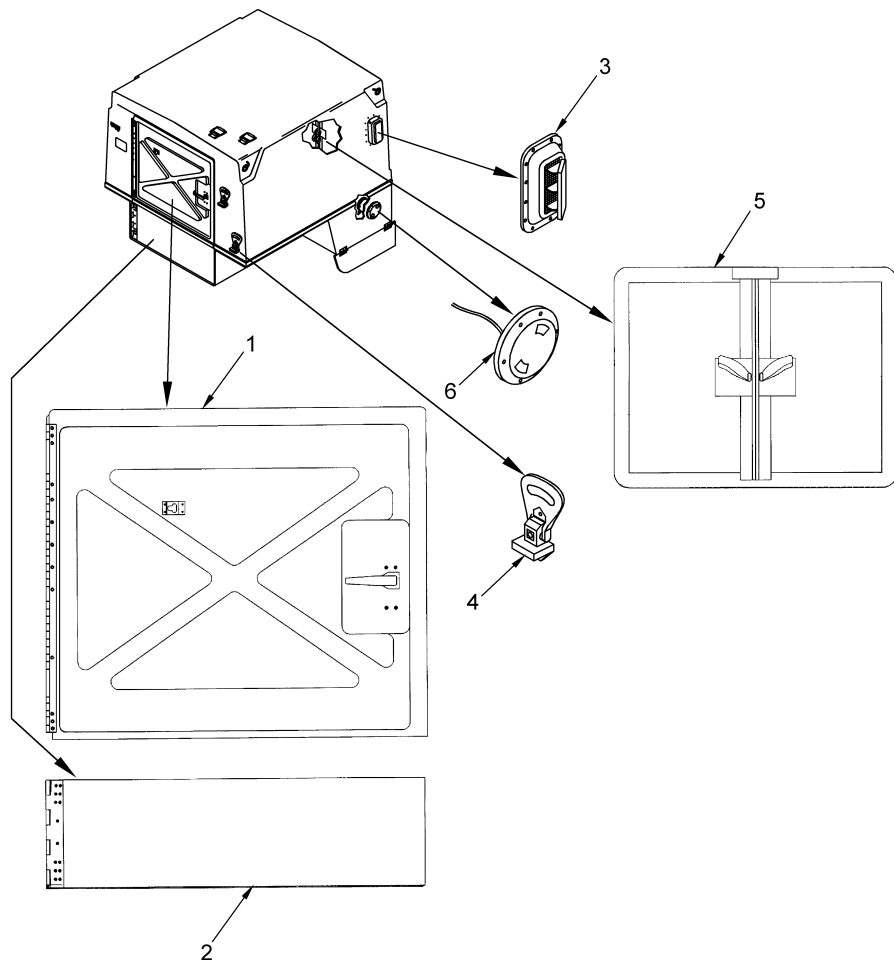

CBC Controls

0005 00-1

Table 0005 00-1. CBC Controls

KEY	CONTROL	FUNCTION
1	Upper Door Assembly Latch	Handle opens and closes upper door
2	Lower Door Assembly Latch	Handle opens and closes lower door
3	2-Way Ventilator	Grip bar opens and closes 2-way ventilator
4	Folding Step	Extends to provide a step, retracts when not in use
5	Cab Access Door Handles (Web Handles)	Slide doors sideways to provide access between CBC and the HMMWV
6	Access Plate	When unscrewed, provides opening to insert electrical or signal cables into the CBC

THIS WORK PACKAGE COVERS:

Operating Procedures,
Preparation for Movement

INITIAL SETUP:

Maintenance Level

Operator

Tools and Special Tools

Combo Wrench, 9/16" Deep Socket

Materials/Parts

Hardware Kit P/N 103983

OPERATING PROCEDURES

WARNING

Suffocation hazard. Door must remain open while occupied.

Operation of Upper and Lower Doors. Both upper and lower doors can be operated separately or, when latched together, as a unit. The upper door opens and closes by using the handle. The lower door latch is operated from the inside.

NOTE

There is an override which allows the door to be opened from the inside, in case of emergency.

The lower door swings sideways and is locked in place from inside. When both doors are latched together as a unit, they are operated by the handle on the upper door. With the lower door closed and locked in place, the upper door can be opened and closed separately.

Operation of Cab Access Door. The cab access door is composed of two sliding halves, which can be operated by web handles.

Operation of 2-Way Ventilators. The 2-way ventilators can be opened and closed by operating grip bars from inside the CBC.

Operation of Folding Steps. The two folding steps are spring-loaded and are manually operated. Steps are extended for use when access to top of CBC is required, and retracted when not in use.

DECALS AND INSTRUCTION PLATES

The following stenciled instructions plus a data plate decal are provided on the CBC:

- **SUFFOCATION HAZARD. DOORS MUST REMAIN OPEN WHILE OCCUPIED**
 This instruction is located inside on the upper door of the CBC and serves as a warning.
- **ELECTRICAL CABLE PORT**
 This instruction is located directly below the access plates, on either side of the CBC. It indicates that electrical cables may be pushed through the opening when the access plate is removed.
- **CBC LIFT ONLY**
 This instruction is located on each upper corner of the CBC indicating where to attach chains or straps for hoisting the CBC.
- A data plate decal is permanently affixed to the CBC shell. It is located on the aft road side and lists manufacturer, part number, serial number, etc. of the CBC. See WP 0002 00, Major Components illustration for location and illustration below for detailed information.

NOMENCLATURE: CARGO BED COVER (CBC)
 HMMWV, TYPE I

MFG. FOR: U.S. ARMY - [CUSTOMER NAME]
 BY: PLASTICS RESEARCH CORPORATION

PART NO. 
 51489-103984

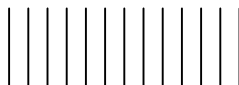
SERIAL NO. 
 XX-XXXX

CONTRACT NO.: XXXXXX-XX-X-XXXX
 DATE OF MFG.: XX XX
 OUTSIDE DIMENSIONS: 83.3L X 83.0W X 63.5H
 NSN: 5411-01-467-3243
 TARE WEIGHT: 450 LBS

Data Plate

PREPARATION FOR MOVEMENT

After the CBC has been installed onto the bed of a vehicle and is ready to be moved, ensure that the following have been accomplished prior to movement:

- Disconnect electrical or signal cables and close access plates.
- Close and secure storage access panels with strap provided.
- Fold and stow ladder inside CBC and secure with adjustable ratchet strap assembly.
- Disconnect upper door from door holder and close both upper and lower doors.

END OF TASK

THIS WORK PACKAGE COVERS:

Emergency Procedures

INITIAL SETUP:

Maintenance Level

Operator

Tools and Special Tools

Mallet, NSN 5120-00-926-7116

Materials/Parts

EMERGENCY PROCEDURES

WARNING

Do not remain inside the CBC with door closed. There is a suffocation hazard. A person inside the CBC can exit quickly (even with the external latch padlocked) by operating the inside handle to open the door.

In the event that personnel is accidentally locked inside the CBC, an override on the latch allows the upper door to be opened from the inside. See Override Door Latch illustration below.

A secondary exit is available through the cab access door located at the front of the CBC. Slide both halves sideways by gripping the web handles.

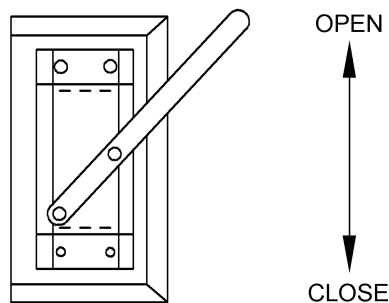

Override Door Latch

UNUSUAL ENVIRONMENTAL CONDITIONS

ICE

If ice forms around the door locks, use mallet to break ice. Gently tap near or at the door lock to free handle for movement.

CAUTION

Be careful when tapping at or near handle. Too much force may damage or break the handle.

If ice forms on the hinges, break ice by gently tapping on hinges until free movement of door is obtained.

RAIN, WIND AND SAND STORM

In case of severe rain, wind or sand storm conditions, ensure that both ventilators, access plates and all doors are closed.

END OF TASK

CHAPTER 3

OPERATOR'S TROUBLESHOOTING PROCEDURES
FOR
CARGO BED COVER (CBC) HMMWV, TYPE I

TM 10-5411-231-13&P

CARGO BED COVER (CBC) HMMWV, TYPE I
TABLE OF CONTENTS

Subject	Page
TROUBLESHOOTING PROCEDURES	0008 00-1
GENERAL	0008 00-1

GENERAL

The troubleshooting procedure consists of a table listing the malfunctions, tests or inspections, and corrective actions required to return the CBC to normal operation. Perform the steps in the order they appear for each heading in Table 0008 00-1.

Table 0008 00-1. Troubleshooting Procedures

MALFUNCTION	TEST OR INSPECTION	CORRECTIVE ACTION
Mounting holes on HMMWV and CBC will not align	Inspect holes in CBC	Using a file, gently elongate holes in CBC to match holes in HMMWV
Upper door does not secure	Check for bent latch assembly rod	Straighten rod. If not possible, replace latch assembly
Door locks stick and handles are hard to move	Check for proper lubrication	Lubricate all moving parts
Water leaks into CBC	Inspect door seals	Replace defective door seal(s)
Ventilators will not close	Check for obstruction such as sand particles, grit or dirt	Clean with approved cleaning solution and lubricate moving parts
Door gaskets will not seal	Inspect seals around doors for wear	Replace defective door seals

END OF TASK

CHAPTER 4

OPERATOR'S MAINTENANCE INSTRUCTIONS
FOR
CARGO BED COVER (CBC) HMMWV, TYPE I

TM 10-5411-231-13&P

CARGO BED COVER (CBC) HMMWV, TYPE I
TABLE OF CONTENTS

Subject	Page
GENERAL	0009 00-1
INSPECTION	0009 00-1
LUBRICATION SERVICE INTERVALS	0009 00-2
CLEANING	0009 00-2
PREVENTIVE MAINTENANCE CHECKS AND SERVICES (PMCS)	0009 00-3

THIS WORK PACKAGE COVERS:

PMCS Procedures

INITIAL SETUP:

Maintenance Level

Operator

GENERAL

Preventive Maintenance Checks and Services (PMCS) are performed to keep the CBC in good operating condition. The checks are used to find, correct, or report problems. Operators are to do the PMCS jobs keeping in mind the following guidelines:

Before you begin using the CBC, do Before PMCS.

After using the CBC, do After PMCS.

If you find something wrong when performing PMCS, fix it if you can, using unit maintenance procedures.

The right-hand column of the PMCS table lists conditions that make the CBC not fully mission capable. Write up the discrepancies not fixed on DA Form 2404 for unit support maintenance. Further information on how to use this form, see DA PAM 738-750.

If tools required to perform PMCS are not listed in WP 0023 00, notify unit maintenance.

INSPECTION

Look for signs of trouble. Senses help here. You can feel, smell, hear, or see many problems that can be eliminated before they get worse. Inspect to see if items are in good condition. Are components correctly installed and secured? Is any damage to the shell or components visible? Are all rubber seals tight and not leaking? Are all bolts and nuts tightly secured? Correct any faults or notify unit maintenance.

There are common items to check on the CBC. These include the following:

- Nuts, bolts, washers and rivets.
- Adhesives relating to deterioration, degradation and peeling.
- Sealers relating to deterioration and degradation.
- Paint relating to deterioration and peeling.

LUBRICATION SERVICE INTERVALS

Lubricate components using MOBILUX EP023 grease or equivalent. Recommended lubrication is every 3 months, or as required.

CLEANING

Proper cleaning of the CBC components is an integral part of maintenance. It can help prevent possible problems in the future, so make it a habit to clean all CBC components whenever necessary. Clean the shell with a brush and mild soapy water, then let air dry.

Cleaning of surfaces for repair/replacement parts: after removal of original parts, remove existent sealant.

TM 10-5411-231-13&P

CARGO BED COVER (CBC) HMMWV, TYPE I

0009 00

PREVENTIVE MAINTENANCE CHECKS AND SERVICES (PMCS)

Table 0009 00-1. Preventive Maintenance Checks and Services for CBC HMMWV, Type I

ITEM NO.	INTERVAL	MAN-HOUR	ITEM TO BE CHECKED OR SERVICED	PROCEDURE	EQUIPMENT NOT READY/ AVAILABLE IF:
1	Before After	0.8	CBC Shell (1)	Visually inspect for damage such as cracks or holes. Check storage access panel assembly.	Shell is damaged.
2	Before After	0.1	Upper Door (2)	Check for movement of door by inspecting hinge. Check for proper operation of door lock. Check seals. Check door holder components.	Hinge is defective or rusted, latch assembly and door holder components are defective or broken, seals are deteriorated causing leakage.
3	Before After	0.1	Lower Door (3)	Check for movement of door by inspecting hinge. Check for proper operation of door lock. Check seals.	Hinge is defective or rusted, door lock is defective or broken, seals are deteriorated causing leakage.
4	Before After	0.1	Cab Access Door (4)	Check for movement of both door halves.	Doors stick or move erratically.
5	Before After	0.1	2-Way Ventilators (5)	Check for movement of ventilators.	Ventilators do not open or close properly.
6	Before After	0.1	Folding Steps (6)	Check that steps fully extend and retract.	Steps do not extend or retract.
7	Before After	0.1	Lifting Rings (7)	Check for damage or loose hardware on lifting rings.	Lifting rings are damaged or hardware not tight.

Table 0009 00-1. Preventive Maintenance Checks and Services for CBC HMMWV, Type I - Continued

ITEM NO.	INTERVAL	MAN-HOUR	ITEM TO BE CHECKED OR SERVICED	PROCEDURE	EQUIPMENT NOT READY/ AVAILABLE IF:
8	Before After	0.1	Chest Handles (8)	Check for damage or stiff movement of chest handles.	Chest handles are damaged or stick.
9	Before After	0.1	Ladder (9)	Inspect ladder.	Ladder does not fold or unfold or steps are broken.

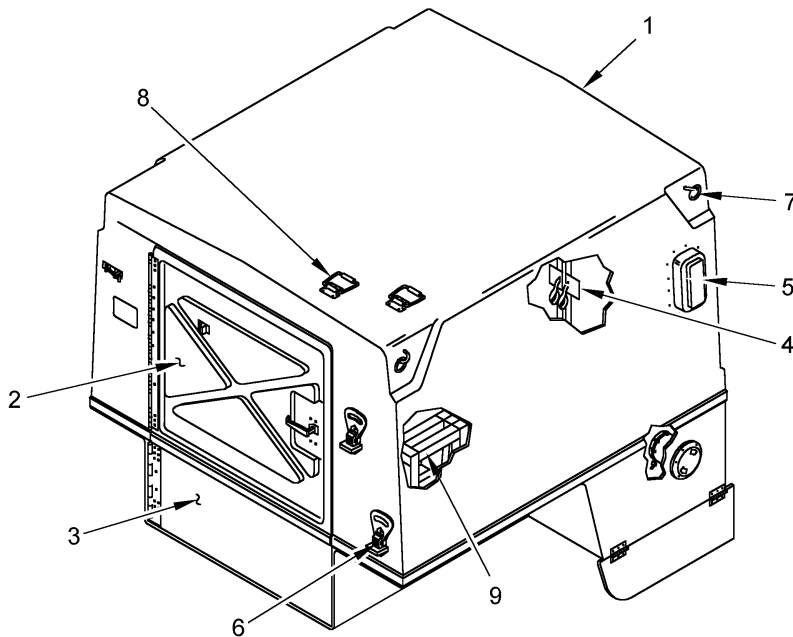

END OF TASK

CHAPTER 5

UNIT MAINTENANCE INSTRUCTIONS
FOR
CARGO BED COVER (CBC) HMMWV, TYPE I

TM 10-5411-231-13&P

CARGO BED COVER (CBC) HMMWV, TYPE I
TABLE OF CONTENTS

Subject	Page
SERVICE UPON RECEIPT	0010 00-1
UNPACKING	0010 00-1
CHECKING UNPACKED EQUIPMENT	0010 00-1
ASSEMBLY AND PREPARATION FOR USE	0010 00-1
INSTALLATION	0010 00-2
STORAGE AND SHIPMENT	0010 00-4
UPPER DOOR ASSEMBLY	0011 00-1
DOOR HOLDER	0012 00-1
LOWER DOOR ASSEMBLY.....	0013 00-1
CAB ACCESS DOOR	0014 00-1
ACCESS PLATE	0015 00-1
STORAGE ACCESS PANEL ASSEMBLY.....	0016 00-1
2-WAY VENTILATOR.....	0017 00-1
FOLDING STEP.....	0018 00-1
CHEST HANDLE	0019 00-1
24-INCH LADDER	0020 00-1

THIS WORK PACKAGE COVERS:

Unpacking, Assembly and Preparation for Use, Installation

INITIAL SETUP:

Maintenance Level

Unit

Tools and Special Tools

Wrench, 9/16" Socket

Philips #3 Screwdriver

1-Ton Lifting Device

7/32" Allen Wrench

Personnel Required

Forklift Operator

2 Personnel (Non MOS specific)

UNPACKING

The CBC is shipped as a complete, self-contained assembly. It is bolted to a wooden pallet, compatible with 463L specifications. The CBC is attached to the pallet with three bolts, rubber gaskets, flat washers and nuts at the forward end and three screws, mounting plates, flat washers and nuts at the aft end.

1. Using socket wrench, remove three bolts, rubber gaskets and nuts holding forward end of the CBC to the pallet.
2. Using screwdriver, remove three screws, mounting plates, washers and nuts holding aft end of the CBC to the pallet. Save hardware in a plastic bag for future use in reshipment.

CHECKING UNPACKED EQUIPMENT

Inspect the equipment for damage incurred during shipment. If the equipment has been damaged, report the damage on SF 361, Transportation Discrepancy Report.

Check the equipment against the packing slip to see if the shipment is complete. Report all discrepancies in accordance with applicable service instructions (e.g. for Army instructions, see DA PAM 738-750)

ASSEMBLY AND PREPARATION FOR USE

The CBC requires an installation kit to be installed onto a HMMWV vehicle. It is installed as a complete unit. No assembly is required.

Open both ventilators to allow fresh air to be circulated. If electronic equipment is to be used inside the CBC, determine if electrical power will be supplied from the road side or curb side of the CBC. Open the access plate facing the power source by rotating it counterclockwise. When opened, the access plate will be suspended by a lanyard attached inside the CBC.

Detach the pallet from CBC by removing the six bolts, nuts and washers. Save hardware for later use in reshipment. Attach a lifting device capable of lifting at least 1 ton to each of four lift rings located near the top corners of the CBC, and remove from pallet. The CBC is ready to be installed.

WARNING

Safe loading of the CBC requires two personnel. Stay clear of the unit while lifting, as serious injury can result if unit swings or drops and hits personnel.

INSTALLATION

Attach CBC to a lifting device by hooking onto the four lift rings and set CBC onto a HMMWV. Open CBC upper and lower doors. Carefully align the six predrilled holes on floor of CBC with holes located on HMMWV bed.

Remove the kit installation hardware (P/N 104244) supplied and located in a bag attached to the 24" ladder. Using this hardware, attach CBC to HMMWV as follows and refer to the CBC Installation illustration.

1. Insert three bolts (2) with three rubber gaskets (6) through the holes on top, located at the forward end of the CBC. From below, attach three flat washers (3) and three self-locking nuts (5). Attach plates (7), one on the left side and one on the right side of CBC underneath the HMMWV. Attach plate (8) with hole in center, in the center of CBC, and underneath the HMMWV. See illustration. Hand tighten.
2. Insert three screws (4) through the holes on top (through the door frame tabs), located at the aft end of the CBC.
3. From below, attach three flat washers (3) and three self-locking nuts (5). Hand tighten.
4. Securely tighten all six nuts (5) from below.

Lift Ring**END OF TASK****0010 00-2**

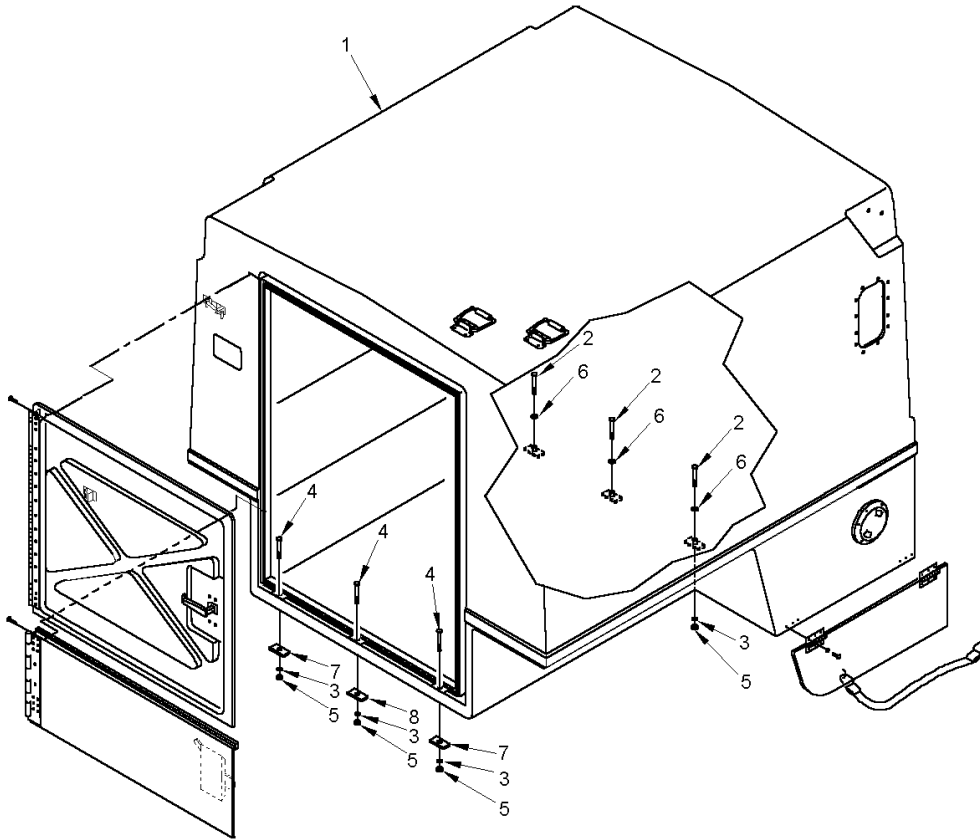

CBC Installation

LEGEND:

CBC (1)
BOLT (2)
FLAT WASHER (3)
SCREW (4)

NUT (5)
RUBBER GASKET (6)
MOUNTING PLATE 104100-1 (7)
MOUNTING PLATE 104100-3 (8)

STORAGE AND SHIPMENT

If the CBC is being prepared for storage, make sure that 2-way ventilators, storage access panels, access plates and upper and lower doors are closed. Secure the 24" folding step ladder to the inside the CBC with the adjustable ratchet strap assembly located inside the CBC. Place the installation kit in a bag and attach the bag to the ladder for storage. Before closing doors, be sure that any equipment stored inside the CBC has been removed or secured. Bolt the CBC onto the shipping pallet in which it was delivered, or a suitable substitute. Store the CBC with pallet in a dry place until ready for shipment.

THIS WORK PACKAGE COVERS:Remove, Replace

INITIAL SETUP:**Maintenance Level**

Unit

Tools and Special Tools

Screwdriver, Philips #2

Screwdriver, Philips #3

Wrench, 7/16" Socket

Drill with 1/8" Bit

Riveter, Blind, Hand

Pliers, Needle Nose

Materials/Parts

Screws 1/4-20; Washers, Flat

No. 10; Lock Nuts 7/16; Rivets;

Sealing Compound P/N 700145;

Upper Door Ass'y P/N 104013;

2- Point Door Lock P/N 104052

GENERAL

This procedure contains information and instructions to keep CBC upper door assemblies in good working order by removing and replacing damaged parts, or the entire upper door assembly.

REMOVAL

1. Using Philips #3 screwdriver and socket wrench (see WP 0023 00, Table 0023 00-2, Item 1), remove fourteen screws, nuts and washers (1) from door while loosening nuts from outer side of door with combo wrench. This requires 2 personnel. Remove door.
2. To remove 2-point door lock assembly (2) remove and discard two cotter pins (3) from latch bars (4). Remove handle (7) and latch bars.
3. Using Philips #2 screwdriver, remove upper latch bracket (5) by removing two screws and spacers. Save spacers. Loosen nuts with socket wrench from inside. This requires 2 personnel. Remove upper latch bracket. Repeat this procedure for lower latch bracket (6).
4. Remove 2-point door lock by using Philips #3 screwdriver and socket wrench (see WP 0023 00, Table 0023 00-2, Item 1). Remove four screws, nuts and washers while loosening nuts with socket wrench from inside.
5. To remove outside handle of 2-point door lock (2), use drill (see WP 0023 00, Table 0023 00-2, Item 3), and drill out three rivets from inner side of door. Pull off handle.

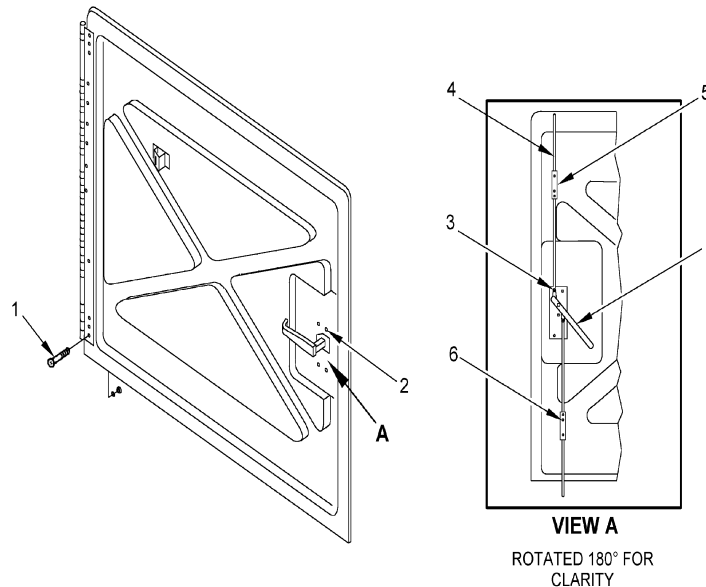

REPLACE

1. Using Philips #3 screwdriver and socket wrench, attach upper door with fourteen screws, nuts and washers (1) Before tightening nuts from outer side of door with socket wrench, apply sealer around screw holes to prevent water leakage. Tighten securely.
2. Using riveter (see WP 0023 00, Table 0023 00-2, Item 2), attach outside handle on 2-point door lock (2) with three rivets from inside.
3. Using Philips #2 screwdriver and socket wrench, attach 2-point door lock with four screws, nuts and washers. Tighten nuts with socket wrench from inner side of door. Apply sealer around screws.
4. Attach upper latch bracket (5), bracket hole facing up and lower latch bracket (6), bracket hole facing down, including spacers, with two screws, nuts and washers for each bracket. Realign spacers, then tighten. DO NOT OVERTIGHTEN.
5. Insert long latch bar into upper bracket and short latch bar into lower bracket. Align holes on latch bars with holes on handle (7).
6. Insert two new cotter pins (3) to secure latch bars and handle. This requires 2 personnel.

END OF TASK

THIS WORK PACKAGE COVERS:Remove, Replace

INITIAL SETUP:**Maintenance Level**

Unit

Tools and Special Tools

Screwdriver, Philips #2

Wrench, 3/8" Socket

Drill with 1/8" Bit

Materials/Parts

Screws 10-24;

Washers, Flat No. 10;

Nut, Self-Lock 10-24;

Door Holder P/N 104054;

Spring Clip P/N 1723A1;

Sealing Compound

P/N 700145

GENERAL

This procedure contains information and instructions to keep CBC door holder assemblies in good working order by removing and replacing damaged parts, or the entire door holder assembly.

REMOVAL

1. Using Philips screwdriver and socket wrench (see WP 0023 00, Table 0023 00-2, Item 1), loosen nuts (1) on inside corner of CBC with socket wrench. Remove four screws, washers and nuts from door holder on outside corner of CBC. Remove door holder.
2. Using Philips screwdriver and socket wrench (see WP 0023 00, Table 0023 00-2, Item 1), loosen nuts from inner side of door, with socket wrench. Remove four screws, washers and nuts (2) from door holder bracket (3) on upper door. This requires 2 personnel. Remove door holder bracket.
3. Using drill (see WP 0023 00, Table 0023 00-2, Item 3), drill out one pop rivet (4) and remove spring clip (5).

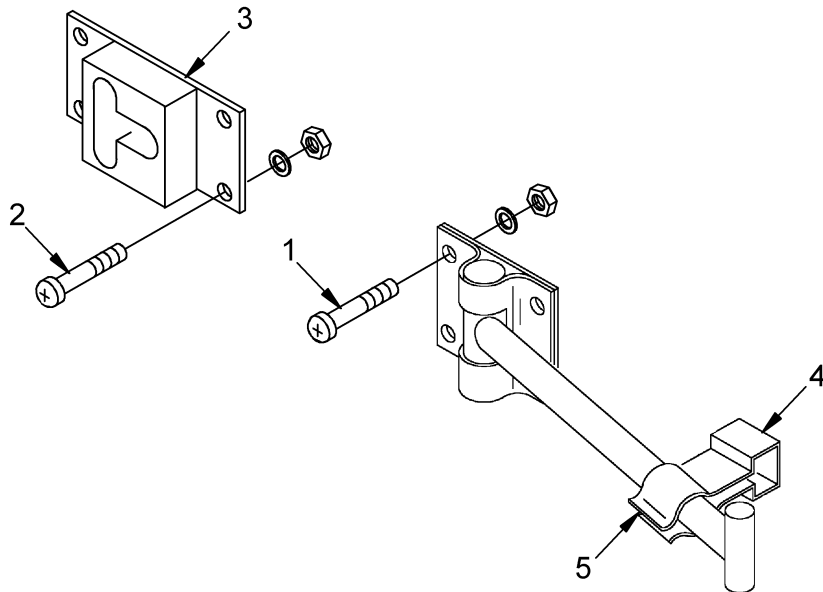

REPLACE

1. Using Philips screwdriver and socket wrench, attach door holder to outside corner of CBC. Replace four screws, washers and nuts (1) and align with existing holes. Before tightening nuts from inside CBC, apply sealer around screws. Tighten nuts securely.
2. Using Philips screwdriver and socket wrench, attach door holder bracket (3) to upper door. Replace four screws, washers and nuts (2) and align with existing holes. Before tightening nuts from inner side of door, apply sealer around screws. Tighten nuts securely.
3. Attach spring clip (5) to CBC with screw, nut and washer. Tighten securely.

END OF TASK

THIS WORK PACKAGE COVERS:

Remove, Replace

INITIAL SETUP:

Maintenance Level

Unit

Tools and Special Tools

Screwdriver, Philips #3
Wrench, 7/16" Socket
Combo Wrench, 3/8"

Materials/Parts

Screws 1/4-20; Washers,
Lock No. 10; Lock Nuts,
1/4-20; Sealing Compound
P/N 700145; Lower Door
Assy P/N 104014; 3-Point
Door Lock P/N 104053

GENERAL

This procedure contains information and instructions to keep CBC lower door assemblies in good working order by removing and replacing damaged parts, or the entire lower door assembly.

REMOVAL

1. Using Philips screwdriver and socket wrench (see WP 0023 00, Table 0023 00-2, Item 1), remove eight screws, nuts and washers (1) from door while loosening nuts from outer side of door with wrench. Remove door.
2. Using Philips screwdriver and open end of 3/8" combo wrench, remove four screws, nuts and washers and remove striker plate (2).
3. Using Philips screwdriver and socket wrench, remove four screws, nuts and washers and remove 3-point door lock (3).

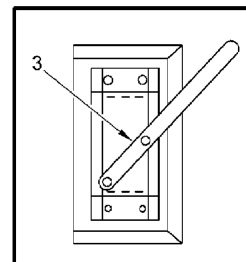
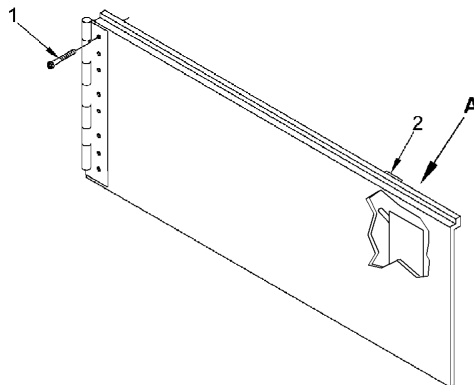

VIEW A
ROTATED 180° FOR
CLARITY

REPLACE

1. Using Philips screwdriver and socket wrench, attach lower door with eight screws, nuts and washers (1). Apply sealer around screws. Tighten securely.
2. Using Philips screwdriver and open end of combo wrench, replace four screws, nuts and washers, and replace striker plate (2).
3. Using Philips screwdriver and socket wrench, replace 3-point door lock (3) with four screws, nuts and washers. Tighten securely.

END OF TASK

THIS WORK PACKAGE COVERS:

Remove, Replace

INITIAL SETUP:

Maintenance Level

Unit

Tools and Special Tools

Drill with 1/8" Bit

Materials/Parts

Screws 10-24 x 5/8 lg;
Washers #10; Nuts 10-24
Self-Lock; Cab Access Door
P/N 104002; Sealing
Compound P/N 700145

GENERAL

This procedure contains information and instructions to keep CBC cab access door assemblies in good working order by removing and replacing damaged parts or the entire cab access door.

REMOVAL

1. Using drill (see WP 0023 00, Table 0023 00-2, Item 3), drill out eleven pop rivets (1) holding the upper track (2) to the CBC shell. Remove track and then remove both door halves (3).

REPLACE

1. Apply sealer across entire back of track.
2. Set door halves into rail of lower track (4). Set upper track (2) with sealer applied on top of door halves against CBC. Fasten with eleven screws, nuts and washers. Tighten securely.

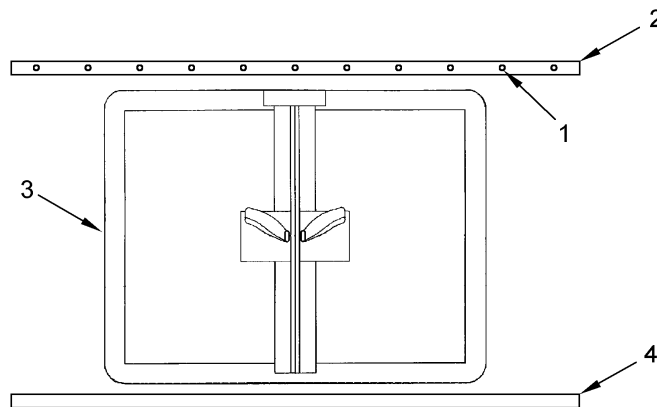

END OF TASK

0014 00-1/2 blank

THIS WORK PACKAGE COVERS:

Remove, Replace

INITIAL SETUP:

Maintenance Level

Unit

Tools and Special Tools

Screwdriver, Philips #2

Wrench, 3/8" Socket

Materials/Parts

Screws 10-24, .88 lg; Washers,

Flat No. 10; Washers, Lock No. 10;

Nuts 10-24; Screw 6-32, .25 lg;

Access Plate P/N AP40W;

Cable Boot P/N 18-4055;

Lanyard P/N MS25083-2CC28;

Sealing Compound P/N 700145

GENERAL

This procedure contains information and instructions to keep CBC access plate assemblies in good working order by removing and replacing damaged parts.

REMOVAL

1. Using Philips screwdriver and wrench (see WP 2300 00, Table 0023 00-2, Item 1), remove screw, nut and washer (1) holding lanyard (2) to the inside of CBC shell, by loosening nut from inside.
2. Turn access plate (5) counter-clockwise and remove.
3. Using Philips screwdriver and wrench, remove additional five screws, nuts and washers (3) from inside CBC on cable boot (4), by loosening nuts from inside. Two personnel are required. Remove cable boot.
4. Remove other end of lanyard from access plate by removing screw.

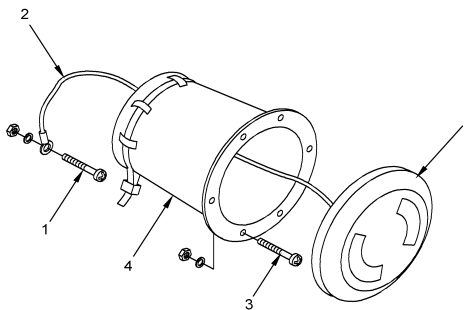

REPLACE

1. Apply sealer P/N 700145 around the outside of opening and seat cable boot into opening.
2. Fasten cable boot with five screws, nuts and washers (3), screws from outside, and secure tightly.
3. Re-install lanyard and access plate with additional screw.

END OF TASK

THIS WORK PACKAGE COVERS:

Remove, Replace

INITIAL SETUP:

Maintenance Level

Unit

Tools and Special Tools

Screwdriver, Philips #2

Combo Wrench, 7/16"

Drill with 1/8" Bit

Materials/Parts

Screws 10-24 x 5/8"; Washers, Flat

No. 10; Nuts, 10-24 Self-Lock;

Storage Access Panel Ass'y

P/N 103999-1; Storage Access

Panel Ass'y P/N 103999-3;

Footman's Loop, Rubber Strap;

Sealing Compound P/N 700145

GENERAL

This procedure contains information and instructions to keep CBC storage access panel assemblies in good working order by removing and replacing damaged parts.

REMOVAL

1. Using drill (see WP 0023 00, Table 0023 00-2, Item 3), drill out three rivets (1) from each of the two hinges (2). Remove storage access panel assembly (3) from CBC.
2. Remove rubber strap (5).
3. Drill out two rivets on footman's loop (4) and remove footman's loop.

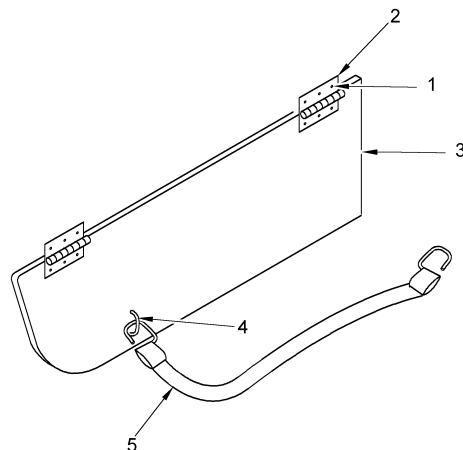

REPLACE

1. Using screwdriver and wrench (see WP 0023 00, Table 0023 00-2, Item 1), attach hinges (2) on storage access panel assembly (3) to CBC with screws, nuts and washers. Before tightening, apply sealer.
2. Attach footman's loop (4) with screws, nuts and washers to storage access panel assembly (3) and replace rubber strap (5).

END OF TASK

TM 10-5411-231-13&P

CARGO BED COVER (CBC) HMMWV, TYPE I
2-WAY VENTILATOR

0017 00

THIS WORK PACKAGE COVERS:

Remove, Replace

INITIAL SETUP:

Maintenance Level

Unit

Tools and Special Tools

Screwdriver, Philips #2

Wrench, 3/8" Socket

Materials/Parts

Screws, 10-24 x .63 lg;

Washers, No. 10; Nuts, 10-24

Self-Lock; 2-Way Ventilator

P/N 104050; Sealing Compound

P/N 700145

GENERAL

This procedure contains information and instructions to keep CBC 2-way ventilator assemblies in good working order by removing and replacing damaged parts.

REMOVAL

1. Using Philips #2 screwdriver, remove twelve screws, nuts and washers (1), while loosening nuts with socket wrench from inside CBC shell. Remove 2-way ventilator by pushing it through to the inside. This requires 2 personnel.

REPLACE

1. Apply sealer P/N 700145 around the inside and outside of flange and screws. Seat 2-way ventilator into opening and, using screwdriver and socket wrench, replace screws, nuts and washers. Tighten securely.

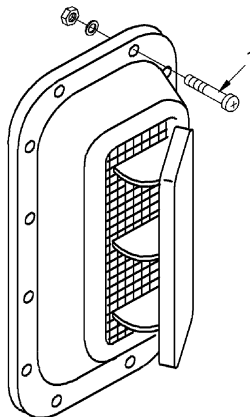

END OF TASK

0017 00-1/(2 blank)

THIS WORK PACKAGE COVERS:

Remove, Replace

INITIAL SETUP:

Maintenance Level

Unit

Tools and Special Tools

Combo Wrench, 1/2"

Wrench, 1/2" Socket

Materials/Parts

Screws 5/16-18, 1.25 lg;

Washers, Lock No. 12; Flat

Washers No. 12; Nuts 5/16-18;

Folding Step P/N 104055;

Sealing Compound P/N 700145

GENERAL

This procedure contains information and instructions to keep CBC folding step assemblies in good working order by removing and replacing damaged parts.

REMOVAL

1. Using socket wrench (see WP 0023 00, Table 0023 00-2 , Item 1), remove two bolts, nuts and washers (1), one set from top part of step and one set from bottom part of step, which hold the folding step to the CBC shell. Hold bolts from the outside with combo wrench, to remove folding step.

REPLACE

1. Apply sealer P/N 700145 to the area to be covered with the step. Replace folding step with bolts, nuts and washers (1). Tighten securely.

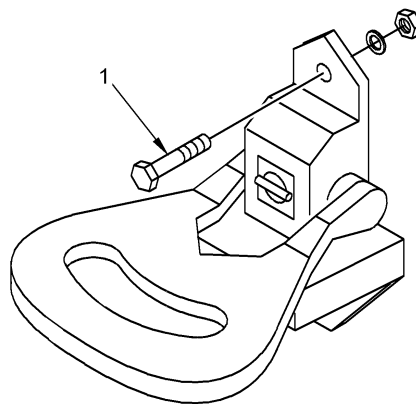

END OF TASK

THIS WORK PACKAGE COVERS:

Remove, Replace

INITIAL SETUP:

Maintenance Level

Unit

Tools and Special Tools

Screwdriver, Philips #2

Wrench, 3/8" Socket

Materials/Parts

Screws 10-24, .88 lg;

Washers, Flat No. 10;

Washers, Lock No. 10;

Nuts 10-24; Chest Handle

P/N 700272

GENERAL

This procedure contains information and instructions to keep CBC chest handle assemblies in good working order by removing and replacing damaged parts.

REMOVAL

1. Using screwdriver and wrench (see WP 0023 00, Table 0023 00-2, Item 1), remove five screws, nuts and washers (1) holding the chest handle to the CBC shell. Hold bolts from inside with socket wrench. Two personnel are required.

REPLACE

1. Apply sealer P/N 700145 to the area to be covered with the chest handle. Replace chest handle and fasten with five screws, nuts and washers (1). Tighten securely.

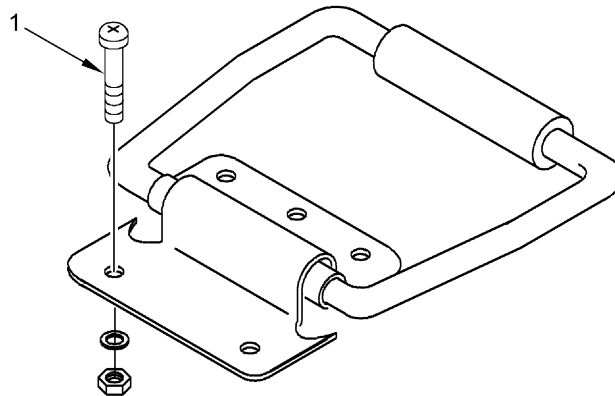

END OF TASK

TM 10-5411-231-13&P

CARGO BED COVER (CBC) HMMWV, TYPE I
24-INCH LADDER

0020 00

THIS WORK PACKAGE COVERS:

Remove, Replace

INITIAL SETUP:

Maintenance Level

Unit

Tools and Special Tools

None

Materials/Parts

24-Inch Ladder P/N 104049

GENERAL

This procedure contains information and instructions to keep CBC 24" ladder assemblies in good working order by removing and replacing damaged parts.

REMOVAL

1. Open ratchet strap assembly by pulling up on inner lock, holding it and pulling it to full down position. Release strap and remove ladder (1).

REPLACE

1. Place ladder against CBC in front of ratchet strap assembly. Connect buckle and move it up and down to tighten the strap. This holds the ladder in place.

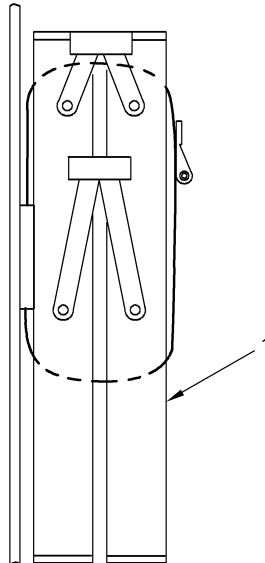

END OF TASK

0020 00-1/(2 blank)

CHAPTER 6

DIRECT SUPPORT MAINTENANCE INSTRUCTIONS
FOR
CARGO BED COVER (CBC) HMMWV, TYPE I

TM 10-5411-231-13&P

CARGO BED COVER (CBC) HMMWV, TYPE I
TABLE OF CONTENTS

Subject	Page
CBC SHELL ASSEMBLY	0021 00-1
GENERAL	0021 00-1
MINOR REPAIR	0021 00-1
MAJOR DAMAGE REPAIR.....	0021 00-4
LIFTING RING REPAIR.....	0021 00-5
INTERIOR MOUNTING INSTRUCTIONS	0021 00-6

THIS WORK PACKAGE COVERS:

Minor Repair, Major Damage Repair, Lifting Ring Repair

INITIAL SETUP:

Maintenance Level

Direct Support

Tools and Special Tools

None

Materials/Parts

Repair Kit P/N 104276-1

Repair Kit P/N 104276-2

GENERAL

This procedure contains information and instructions to keep CBC shell and door fiberglass components in good working order by repairing damaged fiberglass areas.

MINOR REPAIR

For cracks of any size or holes that are less than 6 inches in length, width or diameter on any fiberglass part of the CBC, repair by using Repair Kits P/N 104276-1 and 104276-2. See Tables 0021 00-1 and 0021 00-2 for kit components. For holes larger than 6 inches in length, width or diameter, see Major Damage Repair.

Cracks and Holes. To repair cracks and holes proceed as follows:

WARNING

All chemical materials used in this process are flammable and toxic. Use only in well ventilated areas. Avoid prolonged or repeated breathing of the vapors or contact with the skin. Make repairs to fiberglass parts in a well-ventilated area. Always wear breathing mask, gloves and eye protection.

NOTE

All repairs should be performed on the interior surfaces.

- a. Using 36-grit sandpaper, hand-sand an area approximately 3 inches larger in all directions from the damaged area. This might necessitate removing adjacent components temporarily.

NOTE

An active charcoal filter face mask should be worn when sanding the CARC paint on the interior or exterior of CBC. CARC paint dust is a carcinogenic agent.

Table 0021 00-1. CBC Repair Kit P/N 104276-1 (Shelf Life Items)

PART NUMBER	NOMENCLATURE	QUANTITY
700155	Epoxy Filler, Kit	1
700455	Epoxy Resin Kit, 1 qt A and 1 qt B	1

Table 0021 00-2. CBC Repair Kit P/N 104276-2 (Indefinite Shelf Life Items)

PART NUMBER	NOMENCLATURE	QUANTITY
COML	Brush, Paint, 2 in. wide, Fed. Spec. H-B-4200	3
700062	Mat, Fiberglass, 915 g/m ² (3 oz/ft ²) (2 ft x 3 ft)	2
	MIL-M-43248	
700127	Cloth, Fiberglass, 240 g/m ² (7 oz/yd ²) (3 ft x 4 ft)	2
	MIL-C-19663	
COML *	Polyethylene Sheet (4 ft x 4 ft)	1
COML	Kraft Paper (3 ft x 6 ft)	1
COML	Tongue Depressor	4
COML	Mixing Stick, Wood	4
COML	Gloves, Polyethylene (medium and large)	1 pair
COML	Sandpaper No. 36 Grit, Fed. Spec. P-P-105	4 sheets
COML	Sandpaper No. 120 Grit, Fed. Spec. P-P-105	4 sheets

* Commercially available

- b. Cut a piece of fiberglass mat (P/N 700062) to size plus 3 inches larger in all directions from the damaged area.
- c. Mix epoxy components A and B and apply the mixture (hereinafter referred to as resin) to the sanded area, using a paint brush. Resin has a workable time of approximately 20 minutes after mixing.

WARNING

The resin and acetone (paint remover) must not be allowed to come in contact with sensitive parts of the body. Blindness could result from direct contact with these materials to the eyes. In the event of eye exposure, quickly flush the eyes with water and consult a physician. Use gloves when handling any of these materials.

- d. Apply resin to the fiberglass mat with the brush until the mat is wetted thoroughly.
- e. Apply the fiberglass mat to the interior surface of the shell over the damaged area. The area should be wet with resin.
- f. Cut a piece of fiberglass cloth (P/N 700127) to a size 3 inches larger in all directions from the damaged area.
- g. Apply the fiberglass cloth over the previously installed fiberglass mat. Use a brush to smooth and fair the wet fiberglass mat. Ensure that any air bubbles are evacuated.
- h. Apply resin to the fiberglass cloth. Allow the resin to air cure for 24 hours. In low temperature areas, apply heat, e.g. heat lamp. (Do not use open flame).
- i. Cracks or holes may require filling from the exterior of the shell in addition to the interior repair. This is accomplished by filling with resin and mat, or epoxy filler.
- j. After curing, sand the repaired area, using 36, then 120 grit sandpaper. Wipe clean.
- k. Paint with CARC paint MIL-C-46168 (not supplied in kit), color sand (P/N 700500-6) or camouflage pattern (P/N 103994).

END OF TASK

MAJOR DAMAGE REPAIR

- a. Procedures similar to minor surface repairs apply. When the damage is extensive or sections larger than 6 inches of damaged material need to be cut away, it will be necessary to place a backing plate on the external surface and secure it there. The backing plate, coated with wax or other mold release can be attached with screws and the screw holes filled later after internal patching procedure has been completed and the material cured. The plate may be metal, wood or another suitable material, capable of providing a straight, smooth surface over the hole.
- b. Gloves (see Table 0021 00-2) shall be used to avoid getting resin on hands.

LIFTING RING REPAIR

- a. Using 1/2" combo wrench outside and 1/2" deep socket wrench inside CBC, remove two screws, lock washers and backing plate from inside CBC. Retain the backing plate for installation of the new ring.
- b. Remove U-bolt, flat washer and ring from outside.

WARNING

All chemical materials used in this process are flammable and toxic. Use only in well ventilated areas. Avoid prolonged or repeated breathing of vapors or contact with skin.

- c. Clean old sealant from the screw holes in the shell with acetone. Allow it to dry.
- d. Use sealing compound (P/N 700145) in and around the screw holes.
- e. Install the new lifting rings (P/N 700407), U-bolts (P/N 700406) and attaching hardware. Tighten securely.

END OF TASK

INTERIOR MOUNTING INSTRUCTIONS

Rivnut Fastener Installation

The purpose of the rivnuts is to provide areas for hanging any number of items within the CBC. Rivnuts may be installed on any of the internal stiffening ribs on the CBC's sides or ceiling. It is best to use 5/16 in. flat head rivnuts, P/N 37-115 (B.F. Goodrich).

- a. Drill a .490 in. - .500 in. hole, .850 in. deep into the rib of the CBC.
- b. Insert the rivnut. Screw in C-722 wrench type header and pull the rivnut by rotating the head with an allen wrench.
- c. Remove tool after installation.

END OF TASK

CHAPTER 7
SUPPORTING INFORMATION
FOR
CARGO BED COVER (CBC) HMMWV, TYPE I

TM 10-5411-231-13&P

CARGO BED COVER (CBC) HMMWV, TYPE I
TABLE OF CONTENTS

Subject	Page
SCOPE	0022 00-1
FIELD MANUALS.....	0022 00-1
FORMS	0022 00-1
TECHNICAL MANUALS	0022 00-1
PAMPHLETS	0022 00-1
MILITARY SPECIFICATIONS	0022 00-1
MILITARY STANDARDS	0022 00-1
INTRODUCTION	0023 00-1
THE ARMY MAINTENANCE SYSTEM MAC.....	0023 00-1
MAINTENANCE FUNCTIONS.....	0023 00-1
EXPLANATION OF COLUMNS IN THE MAC.....	0023 00-3
EXPLANATION OF COLUMNS IN THE TOOLS AND TEST EQUIPMENT REQUIREMENTS.....	0023 00-3
EXPLANATION OF COLUMNS IN REMARKS	0023 00-4
TOOLS AND TEST EQUIPMENT REQUIREMENTS FOR THE CBC.....	0023 00-6
SCOPE (RPSTL)	0024 00-1
GENERAL	0024 00-1
EXPLANATION OF COLUMNS IN THE RPSTL	0024 00-1
EXPLANATION OF CROSS REFERENCE INDEX FORMAT AND COLUMNS.....	0024 00-5
SPECIAL INFORMATION	0024 00-6
HOW TO LOCATE REPAIR PARTS	0024 00-6
GROUP 00 (CBC) HMMWV, TYPE I PARTS LIST	0025 00-1
GROUP 01 (CBC) HMMWV, TYPE I PARTS LIST	0026 00-1
COMPONENTS OF END ITEM (COEI) LIST	0027 00-1
EXPENDABLE AND DURABLE ITEMS LIST	0028 00-1

SCOPE

This work package lists all field manuals, forms, technical manuals and miscellaneous publications referenced in this manual.

FIELD MANUALS

Basic Cold Weather Manual	FM 31-70
First Aid for Soldiers	FM 21-11
Mountain Operations	FM 90-6
NBC Decontamination	FM 3-3
Northern Operations	FM 31-71
Vehicle Recovery Operations	FM 20-22

FORMS

Equipment Control Record	DA Form 2408-9
Equipment Inspection and Maintenance Worksheet	DA Form 2404
Transportation Discrepancy Report	SF361
Product Quality Deficiency Report	SF368
Recommended Changes to Equipment Technical Publications	DA Form 2028-2
Recommended Changes to Publications and Blank Forms	DA Form 2028

TECHNICAL MANUALS

Procedures for Destruction of Army Equipment to Prevent Enemy Use (Mobility Equipment Command)	TM 750-244-3
Administrative Storage of Equipment	TM 740-90-1
Preservation, Packaging, and Packing of Military Supplies and Equipment	TM 38-230-2
Operator's Manual For Truck, Utility, Cargo/Troop Carrier, 1-1/4 Ton, 4X4	TM 9-2320-280- Series

PAMPHLETS

Functional User's Manual for the Army Maintenance Management System (TAMMS) DA Pam 738-750

MILITARY SPECIFICATIONS

- MIL-T-704 Treatment and Painting of Material
- MIL-C-46168 Coating, Aliphatic Polyurethane, Chemical Agent Resistant
- MIL-R-7575 Resin, Polyester, Low Pressure Laminating
- AR 750-1 Maintenance of Supplies and Equipment

MILITARY STANDARDS

MIL-STD-209 Lifting and Tiedown Provisions

INTRODUCTION

The Army Maintenance System MAC

This introduction provides a general explanation of all maintenance and repair functions authorized at the two maintenance levels under the Two-Level Maintenance System concept.

This MAC (immediately following the introduction) designates overall authority and responsibility for the performance of maintenance functions on the identified end item or component. The application of the maintenance functions to the end item or component levels, which are shown on the MAC in column (4) as:

Field - includes two columns, Unit Maintenance and Direct Support maintenance. The Unit maintenance column is divided again into two more subcolumns, C for Operator or Crew and O for Unit maintenance.

Sustainment – includes two subcolumns, general support (H) and depot (D).

The tools and test equipment requirements (immediately following the MAC) list the tools and test equipment (both special tools and common tool sets) required for each maintenance function as referenced from the MAC.

The remarks (immediately following the tools and test equipment requirements) contain supplemental instructions and explanatory notes for a particular maintenance function.

Maintenance Functions

Maintenance functions will be limited to and are defined as follows:

1. Inspect. To determine the serviceability of an item by comparing its physical, mechanical, and/or electrical characteristics with established standards through examination (e.g., by sight, sound, or feel.) This includes scheduled inspection and gagings and evaluation of cannon tubes.
2. Test. To verify serviceability by measuring the mechanical, pneumatic, hydraulic, or electrical characteristics of an item and comparing those characteristics with prescribed standards on a scheduled basis, i.e., load testing of lift devices and hydrostatic testing of pressure hoses.
3. Service. Operations required periodically to keep an item in proper operating condition; e.g., to clean (includes decontaminate, when required), to preserve, to drain, to paint, or to replenish fuel, lubricants, chemical fluids, or gases. This includes scheduled exercising and purging of recoil mechanisms. The following are examples of service functions:
 - a. Unpack. To remove from packing box for service or when required for the performance of maintenance operations.
 - b. Repack. To return item to packing box after service and other maintenance operations.
 - c. Clean. To rid the item of contamination.

- d. Touch up. To spot paint scratched or blistered surfaces.
- e. Mark. To restore obliterated identification.
4. Adjust. To maintain or regulate, within prescribed limits, by bringing into proper position, or by setting the operating characteristics to specified parameters.
5. Align. To adjust specified variable elements of an item to bring about optimum or desired performance
6. Calibrate. To determine and cause corrections to be made or to be adjusted on instruments of test, measuring, and diagnostic equipment used in precision measurement. Consists of comparisons of two instruments, one of which is a certified standard of known accuracy, to detect and adjust any discrepancy in the accuracy of the instrument being compared.
7. Remove/install. To remove and install the same item when required to perform service or other maintenance functions. Install may be the act of emplacing, seating, or fixing into position a spare, repair part, or module (component or assembly) in a manner to allow the proper functioning of an equipment or system.
8. Paint. To prepare and spray color coats of paint so that the ammunition can be identified and protected. The color indicating primary use is applied, preferably, to the entire exterior surface as the background color of the item. Other markings are to be repainted as original so as to retain proper ammunition identification.
9. Replace. To remove an unserviceable item and install a serviceable counterpart in its place. "Replace" is authorized by the MAC and assigned maintenance level is shown as the third position code of the Source, Maintenance and Recoverability (SMR) code.
10. Repair. The application of maintenance services, including fault location/troubleshooting, removal/installation, disassembly/assembly procedures and maintenance actions to identify troubles and restore serviceability to an item by correcting specific damage, fault, malfunction, or failure in a part, subassembly, module (component or assembly), end item, or system.

NOTE

The following definitions are applicable to the "repair" maintenance function: Services. Inspect, test, service, adjust, align, calibrate, and/or replace.

Fault location/troubleshooting. The process of investigating and detecting the cause of equipment malfunctioning; the act of isolating a fault within a system or Unit Under Test (UUT).

Disassembly/assembly. The step-by-step breakdown (taking apart) of a spare/functional group coded item to the level of its least component, that is assigned an SMR code for the level of maintenance under consideration (i.e. identified as maintenance significant).

Actions. Welding, grinding, riveting, straightening, facing, machining, and/or resurfacing.

11. Overhaul. That maintenance effort (service/action) prescribed to restore an item to a completely serviceable/operational condition as required by maintenance standards in appropriate technical publications. Overhaul is normally the highest degree of maintenance performed by the Army. Overhaul does not normally return an item to like new condition.
12. Rebuild. Consists of those services/actions necessary for the restoration of unserviceable equipment to a like new condition in accordance with original manufacturing standards. Rebuild is the highest degree of material maintenance applied to Army equipment. The rebuild operation includes the act of returning to zero those age measurements (hours/miles, etc.) considered in classifying Army equipment/components.

Explanation of Columns in the MAC

Column (1) Group Number. Column (1) lists Functional Group Code (FGC) numbers, the purpose of which is to identify maintenance significant components, assemblies, subassemblies, and modules with the Next Higher Assembly (NHA).

Column (2) Component/Assembly. Column (2) contains the names of components, assemblies, subassemblies, and modules for which maintenance is authorized.

Column (3) Maintenance Function. Column (3) lists the functions to be performed on the item listed in column (2). (For detailed explanation of these functions refer to "Maintenance Functions" outlined above).

Column (4) Maintenance Level. Column (4) specifies each level of maintenance authorized to perform each function listed in column (3), by indicating work time required (expressed as man-hours in whole hours or decimals) in the appropriate subcolumn. This work time figure represents the active time required to perform that maintenance function at the indicated level of maintenance. If the number or complexity of the tasks within the listed maintenance function varies at different maintenance levels, appropriate work time figures are to be shown for each level. The work time figure represents the average time required to restore an item (assembly, subassembly, component, module, end item, or system) to a serviceable condition under typical field operating conditions. This time includes item preparation time (including any necessary disassembly/assembly time), troubleshooting/fault location time, and quality assurance time in addition to the time required to perform the specific tasks identified for the maintenance functions authorized in the MAC. The system designations for the various maintenance levels are as follows:

Field:

- C Operator or crew maintenance
- O Unit maintenance
- F Direct Support maintenance

Sustainment

- L Specialized Repair Activity
- H General Support maintenance
- D Depot maintenance

NOTE

The "L" maintenance level is not included in column (4) of the MAC. Functions to this level of maintenance are identified by work time figure in the "H" column of column (4), and an associated reference code is used in the REMARKS column (6). This code is keyed to the remarks and the SRA complete repair application is explained there.

Column (5) Tools and Equipment Reference Code. Column (5) specifies, by code, those common tool sets (not individual tools), common Test, Measurement and Diagnostic Equipment (TMDE), and special tools, special TMDE and special support equipment required to perform the designated function. Codes are keyed to the entries in the tools and test equipment table.

Column (6) Remarks Code. When applicable, this column contains a letter code, in alphabetic order, which is keyed to the remarks table entries.

Explanation of Columns in the Tools and Test Equipment Requirements

Column (1) - Tool or Test Equipment Reference Code. The tool or test equipment reference code correlates with a code used in column (5) of the MAC.

Column (2) - Maintenance Level. The lowest level of maintenance authorized to use the tool or test equipment.

Column (3) - Nomenclature. Name or identification of tool or test equipment.

Column (4) - National Stock Number (NSN). The NSN of the tool or test equipment.

Column (5) - Tool Number. The manufacturer's part number, model number, or type number.

Explanation of Columns in Remarks

Column (1) - Remarks Code. The code recorded in Column (6) of the MAC.

Column (2) - Remarks. This column lists information pertinent to the maintenance function being performed as indicated in the MAC.

Table 0023 00-1. MAC for Cargo Bed Cover (CBC) HMMWV, Type I

(1) GROUP NUMBER	(2) COMPONENT/ ASSEMBLY	(3) MAINTENANCE FUNCTION	(4) MAINTENANCE LEVEL					(5) TOOLS AND EQUIPMENT REFERENCE CODE	(6) REMARKS CODE
			FIELD		SUSTAINMENT				
			UNIT		DIRECT SUPPORT	GENERAL SUPPORT	DEPOT		
			C	O	F	H	D		
00	CBC ASSEMBLY	Inspect	0.8					1	A D B C
		Repair			4.0				
		Replace Service	0.2	4.5					
01	DOOR ASSEMBLY	Inspect	0.2					1, 2, 3	D
		Repair Replace		2.0					
0101	DOOR, UPPER	Inspect	0.1						D E
		Repair Replace		1.0	2.0				
0102	DOOR LOWER	Inspect	0.1						D F
		Repair Replace		1.0	2.0				
02	2-WAY VENTILATOR	Inspect	0.1					1	
		Replace		0.5					
03	PANEL ASSEMBLY, STORAGE, ACCESS	Inspect	0.1					1	G
		Replace		0.5					
04	PLATE, ACCESS (ELECT. CABLE PORT)	Inspect	0.1					1	H
		Replace		0.5					
05	STEP, FOLDING	Inspect	0.1					1	C
		Replace Service	0.1	0.5					
06	HANDLE, CHEST	Inspect	0.1					1	
		Replace Service		0.5					
07	DOOR, ACCESS, CAB	Inspect	0.1					1, 2, 3	C
		Replace Service	0.1	0.5					

Table 0023 00-2. Tools and Test Equipment for Cargo Bed Cover (CBC) HMMWV, Type I

(1) TOOL OR TEST EQUIPMENT REFERENCE CODE	(2) MAINTENANCE LEVEL	(3) NOMENCLATURE	(4) NATIONAL STOCK NUMBER	(5) TOOL NUMBER
1	O, F	Tool Kit, General Mechanics	5180-00-177-7033	
2	O, F	Riveter, Blind, Hand	5120-01-289-4310	
3	O, F	Drill, Electric, Portable, ¼" CAP, with Drill Bits	5130-00-561-1389	

Table 0023 00-3. Remarks for Cargo Bed Cover (CBC) HMMWV, Type I.

(1) REMARK CODES	(2) REMARKS
A	Perform Preventive Maintenance Checks and Services (PMCS)
B	Remove and Replace Door Holder
C	Lubrication Required for Step, Folding, Pivot Points, Contact Surfaces (Annually)
D	Fiberglass Repair
E	Remove and Replace Hinge; Door, Upper; Lock, 2-Point; Bar, Lock
F	Remove and Replace Hinge; Door, Lower; Lock, 3-Point; Plate, Striker
G	Remove and Replace Footman's Loop, Hook and Tie Down Rubber
H	Remove and Replace Access Plate, Cable Boot and Lanyard

SCOPE

This RPSTL lists and authorizes spare and repair parts; special tools; special test, measurement and diagnostic equipment (TMDE); and other special support equipment required for performance of unit and direct support maintenance of the CBC. It authorizes the requisitioning, issue, and disposition of spares, repair parts, and special tools as indicated by the source, maintenance, and recoverability (SMR) codes.

GENERAL

In addition to this section, this RPSTL is divided into the following sections:

Repair Parts List Work Packages. Work packages containing lists of spares and repair parts authorized by this RPSTL for use in the performance of maintenance. These work packages also include parts with must be removed for replacement of the authorized parts. Parts lists are composed of functional groups in ascending alphanumeric sequence, with the parts in each group listed in ascending figure and item number sequence. Sending units, brackets, filters and bolts are listed with the component they mount on. Bulk materials are listed by item name in FIG. BULK at the end of the work packages. Repair part kits are listed separately in their own functional group and work package. Repair parts for reparable special tools are also listed in a separate work package. Items listed are shown on the associated illustrations.

Special Tools List Work Packages. Work packages containing lists of special tools, special TMDE and special support equipment authorized by this RPSTL (as indicated by Basis of Issue (BOI) information in the DESCRIPTION AND USABLE ON CODE (UOC) column). Tools that are components of common tool sets and/or Class VII are not listed.

Cross-Reference Indexes Work Packages. There are no cross-reference indexes work packages in this RPSTL.

EXPLANATION OF COLUMNS IN THE REPAIR PARTS LIST AND SPECIAL TOOLS LIST (RPSTL) WORK PACKAGES

ITEM NO. (Column (1)). Indicates the number used to identify items called out in the illustration.

SMR CODE (Column (2)). The SMR code containing supply/requisitioning information, maintenance level authorization criteria and disposition instruction, as shown in the following breakout:

<u>Source Code</u>	<u>Maintenance Code</u>		<u>Recoverability Code</u>
-----		-----	-----
XX		XX	X
-----		-----	-----
1st two	3rd position	4th position	5th position:
Positions:	Who can install	Who can do	Who determines
How to get	replace or	complete repair*	disposition action
an item	use the item	on the item	on unserviceable items

*Complete Repair: Maintenance capacity, capability, and authority to perform all corrective maintenance tasks of the "Repair" function in a use/user environment in order to restore serviceability to a failed item.

Source Code. The source code, tells you how to get an item needed for maintenance, repair, or overhaul of an end item/equipment. Explanation of source codes follows.

Source Code	Explanation
PA PB PC PD PE PF PG	Stock items; use the applicable NSN to request/requisition items with these source codes. They are authorized to the level indicated by the code entered in the third position of the SMR code.
	NOTE Items coded PC are subject to deterioration.
KD KF KB	Items with these codes are not to be requested/requisitioned individually. They are part of a kit which is authorized to the maintenance level indicated in the 3rd position of the SMR code. The complete kit must be requisitioned and applied.
MO-Made at unit/ AVUM Level MF-Made at DS/ AVIM Level MH-Made at GS Level ML-Made at SRA MD-Made at Depot	Items with these codes are not to be requested/requisitioned individually. They must be made from bulk material that is identified by the P/N in the DESCRIPTION AND USABLE ON CODE (UOC) column and listed in the Bulk Material group work package of the RPSTL. If the item is authorized to you by the 3rd position code of the SMR code, but the source code indicates it is made at a higher level, order the item from the higher level of maintenance.
AO-Assembled by Unit/AVUM Level AF-Assembled by DS/AVIM Level AH-Assembled by GS level AL-Assembled by SRA AD-Assembled by Depot	Items with these codes are not to be requested/requisitioned individually. The parts that make up the assembled item must be requisitioned or fabricated and assembled at the level of maintenance indicated by the source code. If the third position code of the SMR code authorizes you to replace the item, but the source code indicates the item is assembled at a higher level, order the item from the higher level of maintenance.
XA	Do not requisition an "XA" coded item. Order its next higher assembly. (Also, refer to the NOTE below.)
XB	If an item is not available from salvage, order it using the CAGEC and P/N.
XC	Installation drawings, diagrams, instruction sheets, field service drawings; identified by manufacturer's P/N.

XD Item is not stocked. Order an XD-coded item through normal supply channels using the CAGEC and P/N given, if no NSN is available.

NOTE

Cannibalization or controlled exchange, when authorized, may be used as a source of supply for items with the above source codes, except for those source coded "XA" or those aircraft support items restricted by requirements of AR 750-1.

Maintenance Code. Maintenance codes tell you the level(s) of maintenance authorized to use and repair support items. The maintenance codes are entered in the third and fourth positions of the SMR Code as follows:

Third Position: The maintenance code entered in the third position tells you the lowest maintenance level authorized to remove, replace, and use an item. The maintenance code entered in the third position will indicate authorization to the following levels of maintenance:

Maintenance Code

Application/Explanation

- | | |
|---|--|
| C | Crew or operator maintenance done within unit/AVUM maintenance. |
| O | Unit level/AVUM maintenance can remove, replace, and use the item. |
| F | Direct support/AVIM maintenance can remove, replace, and use the item. |
| H | General support maintenance can remove, replace, and use the item. |
| L | Specialized repair activity can remove, replace, and use the item. |
| D | Depot can remove, replace, and use the item. |

Fourth Position. The maintenance code entered in the fourth position tells you whether or not the item is to be repaired and identifies the lowest maintenance level with the capability to do complete repair (perform all authorized repair functions).

NOTE

Some limited repair may be done on the item at a lower level of maintenance, if authorized by the Maintenance Allocation Chart (MAC) and SMR codes.

Maintenance Code

Application/Explanation

- | | |
|---|--|
| O | Unit/AVUM is the lowest level that can do complete repair of the item. |
| F | Direct support/AVIM is the lowest level that can do complete repair of the item. |

TM 10-5411-231-13&P

CARGO BED COVER (CBC) HMMWV, TYPE I
REPAIR PARTS AND SPECIAL TOOLS LIST (RPSTL)

0024 00

- | | |
|---|---|
| H | General support is the lowest level that can do complete repair of the item. |
| L | Specialized repair activity is the lowest level that can do complete repair of the item. |
| D | Depot is lowest level that can do complete repair of the item. |
| Z | Non-reparable. No repair is authorized. |
| B | No repair is authorized. No parts or special tools are authorized for the maintenance of a "B" coded item. However, the item may be reconditioned by adjusting, lubricating, etc., at the user level. |

Recoverability Code. Recoverability codes are assigned to items to indicate the disposition action on unserviceable items. The recoverability code is shown in the fifth position of the SMR Code as follows:

Recoverability

Code

Application/Explanation

- | | |
|---|---|
| Z | Non-reparable item. When unserviceable, condemn and dispose of the item at the level of maintenance shown in 3rd position of SMR Code. |
| O | Reparable item. When uneconomically repairable, condemn and dispose of the item at the unit level. |
| F | Reparable item. When uneconomically repairable, condemn and dispose of the item at the direct support level. |
| H | Reparable item. When uneconomically repairable, condemn and dispose of the item at the general support level. |
| D | Reparable item. When beyond lower level repair capability, return to depot. Condemnation and disposal of item are not authorized below depot level. |
| L | Reparable item. Condemnation and disposal not authorized below Specialized Repair Activity (SRA). |
| A | Item requires special handling or condemnation procedures because of specific reasons (such as precious metal content, high dollar value, critical material, or hazardous material). Refer to appropriate manuals/directives for specific instructions. |

NSN (Column (3)). The NSN for the item is listed in this column.

CAGEC (Column (4)). The Commercial and Government Entity Code (CAGEC) is a 5-digit code which is used to identify the manufacturer, distributor, or Government agency/activity that supplies the item.

PART NUMBER (Column (5)). Indicates the primary number used by the manufacturer, (individual, company, firm, corporation, or Government activity), which controls the design and characteristics of the item by means of its engineering drawings, specifications, standards, and inspection requirements to identify an item or range of items.

NOTE

When you use an NSN to requisition an item, the item you receive may have a different P/N from the item listed.

DESCRIPTION AND USABLE ON CODE (UOC) (Column (6)). This column includes the following information:

1. The federal item name and, when required, a minimum description to identify the item.
2. P/Ns of bulk materials are referenced in this column in the line entry to be manufactured or fabricated.
3. Hardness Critical Item (HCI). A support item that provides the equipment with special protection from electromagnetic pulse (EMP) damage during a nuclear attack.
4. The statement END OF FIGURE appears just below the last item description in Column (6) for a given figure in both the Repair Parts List and Special Tools List work packages.

QTY (Column (7)). The QTY (quantity per figure) column indicates the quantity of the item used in the breakout shown on the illustration/figure, which is prepared for a functional group, subfunctional group, or an assembly. A "V" appearing in this column instead of quantity indicates that the quantity is a variable and quantity may change from application to application.

EXPLANATION OF CROSS-REFERENCE INDEXES WORK PACKAGES FORMAT AND COLUMNS

1. National Stock Number (NSN) Index Work Package.

STOCK NUMBER Column. This column lists the NSN in National Item Identification Number (NIIN) sequence. The NIIN consists of the last nine digits of the NSN.

<u>NSN</u> 5305-01-574-1467 <u>NIIN</u>	When using this column to locate an item, ignore the first four digits of the NSN. However, the complete NSN should be used when ordering items by stock number.
---	--

FIG. Column. This column lists the number of the figure where the item is identified/located. The figures are in numerical order in the repair parts list and special tools list work packages.

ITEM Column. The item number identifies the item associated with the figure listed in the adjacent FIG. column. This item is also identified by the NSN listed on the same line.

2. Part Number (P/N) Index Work Package. P/Ns in this index are listed in ascending alphanumeric sequence (i.e. vertical arrangement of letter and number combinations which places the first letter or digit of each group in order A through Z, followed by the numbers 0 through 9, and each following letter or digit in like order).

PART NUMBER Column. Indicates the P/N assigned to the item.

FIG. Column. This column lists the number of the figure where the item is identified/located in the repair parts list and special tools list work packages.

ITEM Column. The item number is the number assigned to the item as it appears in the figure referenced in the adjacent figure number column.

SPECIAL INFORMATION.

None required.

HOW TO LOCATE REPAIR PARTS.

1. When NSNs or P/Ns Are Not Known.

First. Using the table of contents, determine the assembly group to which the item belongs. This is necessary since figures are prepared for assembly groups and subassembly groups, and listings are divided into the same groups.

Second. Find the figure covering the functional group or the subfunctional group to which the item belongs.

Third. Identify the item on the figure and note the number(s).

Fourth. Look in the repair parts list for the figure and time numbers. The NSNs and part numbers are on the same line as the associated item numbers.

2. When NSN is known.

First. If you have the NSN, look in the STOCK NUMBER column of the NSN index work package. The NSN is arranged in NIIN sequence. Note the figure and item number next to the NSN.

Second. Turn to the figure and locate the item number. Verify that the item is the one you are looking for.

3. When P/N is known.

First. If you have the P/N and not the NSN, look in the PART NUMBER column of the P/N index work package. Identify the figure and item number.

Second. Look up the item on the figure in the applicable repair parts list work package.

ABBREVIATIONS.

No uncommon abbreviations are used in this RPSTL.

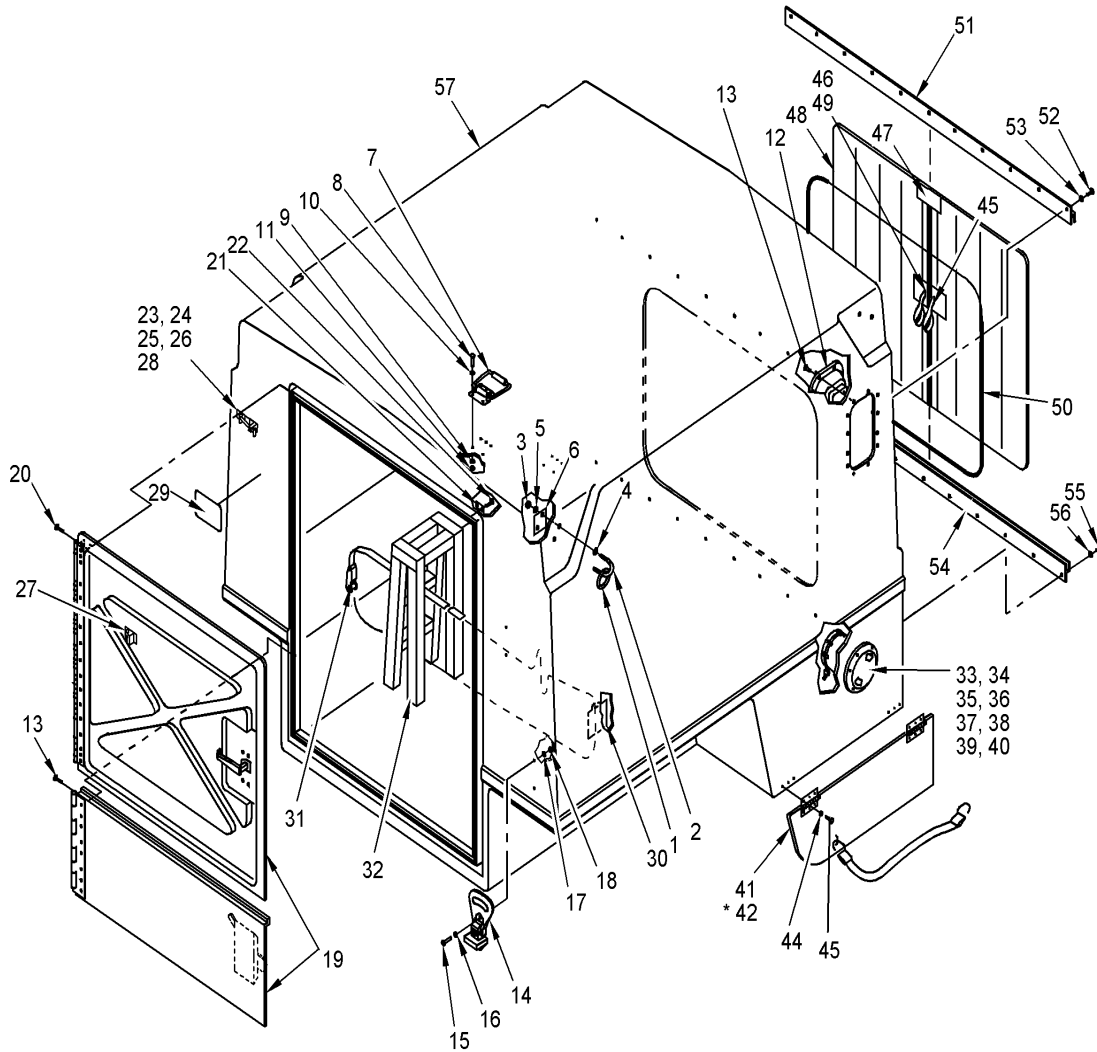

Figure 1. Group 00 CBC

* NOT ILLUSTRATED. LOCATED ON OPPOSITE SIDE (ROAD SIDE) OF CBC

TM 10-5411-231-13&P

CARGO BED COVER (CBC) HMMWV, TYPE I
GROUP 00 CARGO BED COVER PARTS LIST

0025 00

(1) ITEM NO.	(2) SMR CODE	(3) NSN	(4) CAGEC	(5) PART NUMBER	(6) DESCRIPTION AND USABLE ON CODE (UOC)	(7) QTY
					GROUP 00 CBC	
	PDOFF		51489	103984	CARGO BED COVER , HMMWV ASSY	REF
1	PAOZZ		51489	700407	. RING, SS	4
2	PAOZZ		51489	700406	. U-BOLT, 5/16-18	4
3	PAOZZ			MS51971-2	. NUT, 5/16-18 UNC, CRES	16 AP
4	PAOZZ			MS15795-812	. WASHER, FLAT, 5/16	16 AP
5	PAOZZ			MS35338-140	. WASHER, LOCK, 5/16	16 AP
6	PAOZZ		51489	104039	. PLATE, BACKING	4
7	PAOZZ		51489	700272	. HANDLE, CHEST	2
8	PAOZZ			MS51957-64	. SCREW, 10-24, .88LG, CRES	10 AP
9	PAOZZ			MS15795-808	. WASHER, FLAT, #10, CRES	10 AP
10				MS35378-138	. WASHER, LOCK, #10, CRES	10 AP
11				MS35649-204	. NUT, 10-24, CRES	10 AP
12	PAOZZ	5411-01-481-5892	51489	104050	. VENTILATOR, 2 WAY	2
13	PAOZZ			MS51957-64	. SCREW, 10-24, .63 LG, CRES	24 AP
13A	PAOZZ			MS15795-808	. WASHER, FLAT, NO. 10, CRES	24 AP
13B				MS35649-204	. NUT, 10-24, CRES	24 AP
14	PAOZZ	5410-00-984-5065	51489	104055	. STEP, FOLDING	2
15	PAOZZ			MS35307-336	. SCREW, HEX, 5/16-18, 1.25 IN.	4 AP
16				AN970-5	. WASHER, FLAT, WOOD, 5/16, CRES	4 AP
17	PAOZZ			MS35338-140	. WASHER, LOCK, 5/16	4 AP
18				MS51971-2	. NUT, 5/16-18 UNC, CRES	4 AP
19	PAOFF		51489	103988	. DOOR ASSY	1
20	PAOZZ			AD66H	. RIVET, POP	22
21	PAOZZ		51489	103993-1	. PLATE, STRIKE, DELRIN	1
22	PAOZZ			AD66H	. RIVET, POP	2 AP
23	PAOZZ	5340-00-302-1840	51489	104054	. HOLDER, DOOR	1
24	PAOZZ			MS51957-64	. SCREW, 10-24, .88 LG, CRES	8 AP
25	PAOZZ			MS15795-808	. WASHER, FLAT, NO. 10, CRES	8 AP
26	PAOZZ			MS17830-3C	. NUT, SELF-LOCKING, 10-24 CRES	8 AP
27	PAOZZ		3A054	1723A1	. CLIP, SPRING	1
28	PAOZZ			AD66H	. RIVET, POP	1 AP
29	PAOZZ		51489	103698	. PLATE, ID	1
30			51489	103984-5	. UDR*, 2 LAYER, 10X5	1
31	PAOZZ		51489	104021	. STRAP ASSY, RATCHET, LADDER	1
32	PAOZZ	5440-01-481-6010	51489	104049	. LADDER, 24 INCH	1
33	PAOZZ			MS25083-2CC28	. LANYARD	2
34				MS51957-26	. SCREW, PH, 6-32 X, .25 LG, CRES	2 AP
35	PAOZZ		00ZZ9	18-4455	. BOOT, CABLE	2
36	PAOZZ		0HCS5	AP40W	. PLATE, ACCESS	2
37	PAOZZ			MS51957-64	. SCREW, 10-24, .88 LG, CRES	12 AP
38	PAOZZ			MS15795-808	. WASHER, FLAT, NO. 10, CRES	12 AP
39				MS35338-138	. WASHER, LOCK, NO. 10, CRES	12 AP
40				MS35649-204	. NUT, 10-24, CRES	12 AP
41	PAOZZ	2510-01-481-6071	51489	103999-1	. PANEL ASSY, STORAGE ACCESS	1
42	PAOZZ	2510-01-481-6071	51489	103999-3	. PANEL ASSY, STORAGE ACCESS	1

*UNIDIRECTIONAL ROVING

0025 00-3

TM 10-5411-231-13&P

CARGO BED COVER (CBC) HMMWV, TYPE I
GROUP 00 CARGO BED COVER PARTS LIST

0025 00

(1) ITEM NO.	(2) SMR CODE	(3) NSN	(4) CAGEC	(5) PART NUMBER	(6) DESCRIPTION AND USABLE ON CODE (UOC)	(7) QTY
43	PAOZZ		07707	AD66H	. RIVET	24 AP
44				MS15795-808	. WASHER, FLAT, NO. 10, CRES	24 AP
45	PAOZZ		51489	104037	. HANDLE, WEBBING	2
46	PAOZZ		51489	700409	. FOAM RUBBER, .13 X .25	32 IN.
47	PAOZZ		51489	700408	. PAD, RUBBER, 6 X 2 X .09	1
48	PAOZZ	2510-01-481-6056	51489	104002	. DOOR, CAB ACCESS	2
49	PAOZZ		51489	104006	. H-BEAM, CAB ACCESS DOOR	1
50			57137	6100 8-3 X 3/16 C	. TRIM, FLEXIBLE W/SEAL	A/R
51	PAOZZ		51489	104004	. TRACK, CAB ACCESS DOOR	1
52	PAOZZ		07707	AD66H	. RIVET	11 AP
53	PAOZZ			MS15795-808	. WASHER, FLAT, NO. 10, CRES	11 AP
54			51489	104004	. TRACK, CAB ACCESS DOOR	1
55	PAOZZ		07707	AD66H	. RIVET	11 AP
56	PAOZZ			MS15795-808	. WASHER, FLAT, NO. 10, CRES	11 AP
57	XDOFF		51489	103985	. CBC SUBASSY (SHELL)	1

END OF FIGURE

0025 00-4

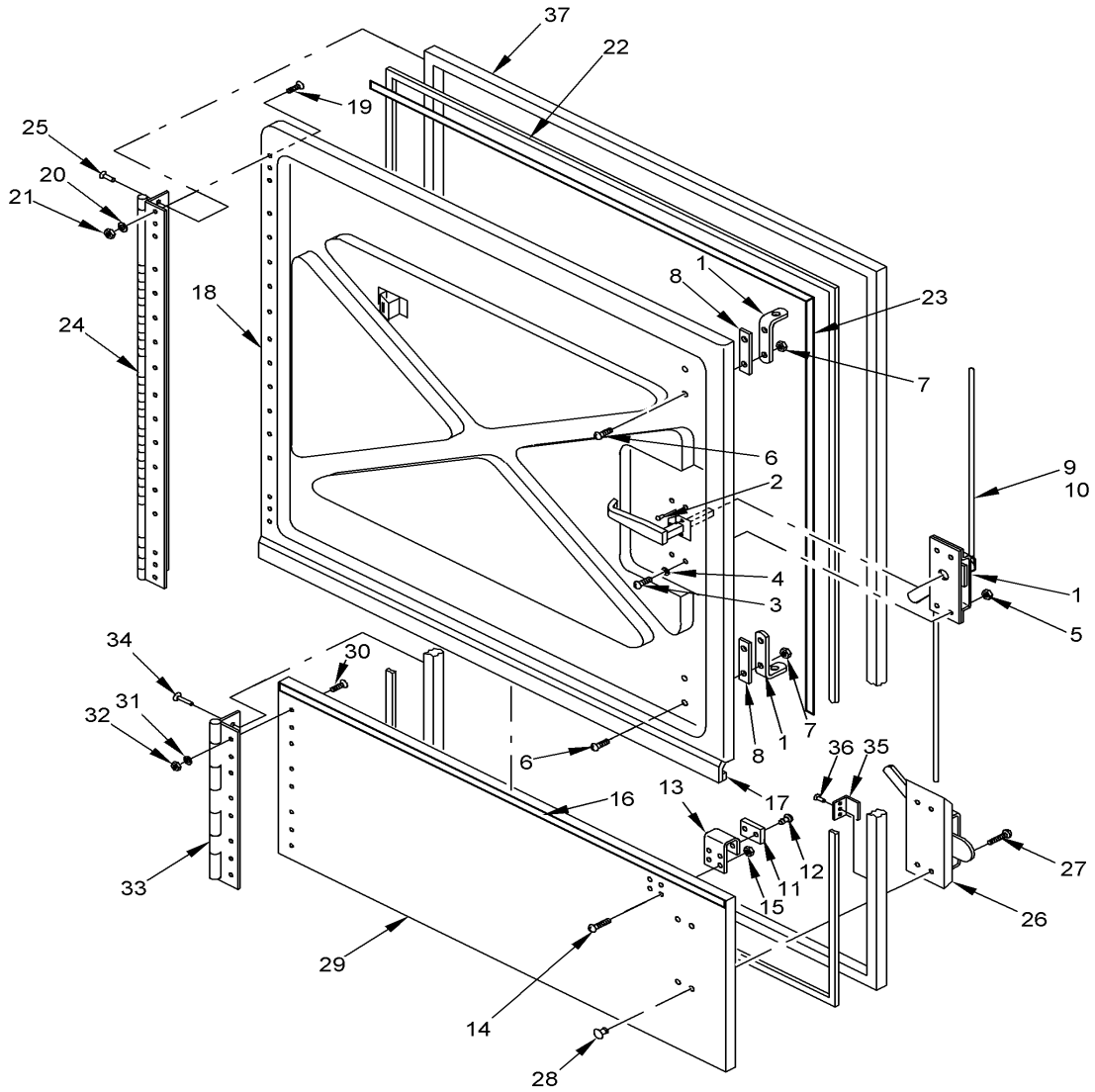

Figure 2. Group 01 CBC

TM 10-5411-231-13&P

CARGO BED COVER (CBC) HMMWV, TYPE I
GROUP 01 CARGO BED COVER PARTS LIST

0026 00

(1) ITEM NO.	(2) SMR CODE	(3) NSN	(4) CAGEC	(5) PART NUMBER	(6) DESCRIPTION AND USABLE ON CODE (UOC)	(7) QTY
					GROUP 01 CBC	
	PAOFF		51489	103988	DOOR ASSY, HMMWV	REF
1	PAOFF	5340-01-481-6503	51489	104052	. LOCK, DOOR, 2 POINT	1
2	PAOFF		07707	AK66H	. RIVET, FLUSH, CLOSED END	3 AP
3	PAOFF			MS51957-81	. SCREW, PH, 1/4-20 X 3/4 LG, CRES	4 AP
4	PAOFF			MS27183-9	. WASHER, FLAT, .25	4 AP
5	PAOFF			MS17830-4C	. NUT, SELF LOCKING, 1/4-20	4 AP
6	PAOFF			MS51958-66	. SCREW, PH, 10-32 X .88 LG	4 AP
7	PAOFF		3A054	90101A225	. NUT, SELF LOCKING, 10-32	4AP
8	PAOFF		51489	104000-3	. SPACER, LATCH	2
9	PAOFF		51489	104038-1	. BAR, LOCK	2
10	PAOFF			MS24665-368	. PIN, COTTER, .13 X .75	2 AP
11	PAOFF		51489	103993-1	. PLATE, UPPER STRIKER	1
12	PAOFF		07707	AD86H	. RIVET, CLOSED END	2 AP
13	PAOFF		51489	103992	. PLATE, STRIKER	1
14	PAOFF			MS51957-69	. SCREW, PH, NO. 10-24 X 1.5 LG, CRES	4 AP
15	PAOFF			MS17830-3C	. NUT, SELF LOCKING, 10-24	4 AP
16	PAOZZ		51489	700409	. GASKET, FOAM RBR .13 X 1.0	A/R
17	PAOFF		51489	104036-5	. GASKET	1
18	PAOFF	2510-01-481-6054	51489	103989	. PANEL, DOOR, UPPER	1
19	PAOFF			MS24693C-98	. SCREW, FH, 1/4 X 1.0 LG	17 AP
20				MS27183-9	. WASHER, FLAT, .25	17 AP
21				90101A230	. NUT, SELF LOCKING, 1/4-20	17 AP
22	PAOFF		51489	104036-3	. GASKET	1
23			51489	700409	. GASKET, FOAM RBR, .13 X 1.0	A/R
24	PAOFF		51489	103995	. HINGE, DOOR, UPPER	1
25	PAOFF		07707	AD86H	. RIVET, CLOSED END	15 AP
26	PAOFF	5340-01-481-6506	51489	104053	. LOCK, DOOR, 3 POINT	1
27	PAOFF			MS51957-85	. SCREW, PH, 1/4-20 X 1.5 LG	4 AP
28	PAOFF		3A057	90598A029	. NUT, PROPELLER	4 AP
29	PAOFF	2510-01-481-6049	51489	103990	. PANEL, DOOR, LOWER	1
30				MS24693-98	. SCREW, FH, 1/4-20 X 1.0 LG	14 AP
31				MS27183-9	. WASHER, FLAT, .25	14 AP
32			3A054	90101A230	. NUT, SELF LOCKING, 1/4-20	14 AP
33	PAOFF		51489	103996	. HINGE, DOOR, LOWER	1
34			07707	AD86H	. RIVET, CLOSED END	14 AP
35	PAOFF		51489	103708	. STRIKE	1
36	PAOFF		07707	SD810BS	. RIVET	3 AP
37	PAOFF		51489	103991	. FRAME, DOOR	1

END OF FIGURE

0026 00-3/(4 blank)

INTRODUCTION

Scope

This work package lists COEI and BII for the Cargo Bed Cover (CBC) HMMWV, Type I to help you inventory items for safe and efficient operation of the equipment.

General

The COEI and BII information is divided into the following lists:

Component of End Item (COEI). This list is for information purposes only and is not authority to requisition replacements. These items are part of the CBC. As part of the end item, these items must be with the end item whenever it is issued or transferred between property accounts. Items of COEI are removed and separately packaged for transportation or shipment only when necessary. Illustrations are furnished to help you find and identify the items.

Basic Issue Items (BII). These essential items are required to place the CBC in operation, operated, and to do emergency repairs. Although shipped separately packaged, BII must be with the CBC during operation when it is transferred between property accounts. Listing these items is your authority to request/requisition them for replacement based on authorization of the end item by the TOE/MTOE. Illustrations are furnished to help you find and identify the items.

Explanation of Columns in the COEI List and BII List

Column (1), Illus Number, gives you the number of the item illustrated.

Column (2), National Stock Number, identifies the stock number of the item to be used for requisitioning purposes.

Column (3), Description, CAGEC, and Part Number, identifies the Federal item name (in all capital letters) followed by a minimum description when needed. The stowage location of COEI is also included in this column. The last line below the description is the CAGEC (commercial and Government entity code) (in parentheses) and the part number.

Column (4), Usable on Code, gives you a code if the item you need is not the same for different models of equipment. These codes are identified below:

<u>Code</u>	<u>Used on</u>
PAA	Model XXX
PAB	Model XXXX
PAC	Model XXXXX

Column (5), U/M (unit of measure), indicates how the item is issued for the National Stock Number shown in column (2).

Column (6), Qty Rqr, indicates the quantity required.

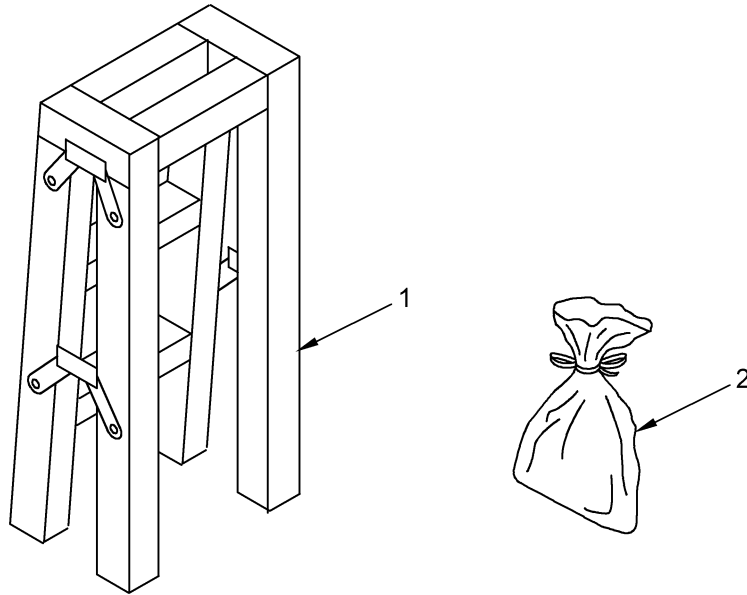

Table 0027 00-1. Components of End Item List (COEI)

(1) ILLUS NUMBER	(2) NATIONAL STOCK NUMBER	(3) DESCRIPTION CAGEC, AND PART NUMBER	(4) USABLE ON CODE	(5) U/M	(6) QTY RQR
1	5440-01-481-6010	24-INCH LADDER (mounted inside CBC) (51489) 104049	FQR	EA	1
2	5411-01-481-5890	KIT INSTALLATION HARDWARE (attached to 24-inch ladder) (51489) 104244	FQR	EA	1

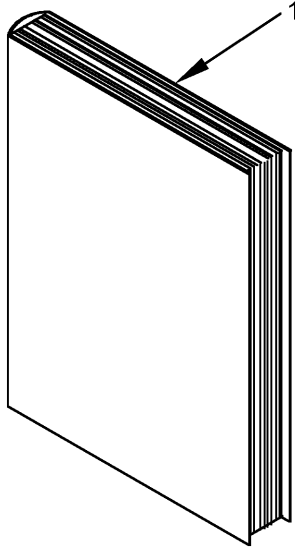

Table 0027 00-2. Basic Issue Items List (BII)

(1) ILLUS NUMBER	(2) NATIONAL STOCK NUMBER	(3) DESCRIPTION CAGEC, AND PART NUMBER	(4) USABLE ON CODE	(5) U/M	(6) QTY RQR
1	N/A	TM 10-5411-231-13&P		EA	1

INTRODUCTION

Scope

This work package lists expendable and durable items that you will need to operate and maintain the CARGO BED COVER (CBC) HMMWV, TYPE I. This list is for information only and is not authority to requisition the listed items. These items are authorized to you by CTA 50-970, Expendable/Durable Items (Except Medical, Class V Repair Parts, and Heraldic Items), or CTA 8-100, Army Medical Department Expendable/Durable Items.

Explanations of Columns in the Expendable/Durable Items List

Column (1) - Item Number. This number is assigned to the entry in the list and is referenced in the narrative instructions to identify the item (e.g. "using a brush (WP 0021 00)").

Column (2) - Level. This column includes the lowest level of maintenance that requires the listed item (C = Operator/Crew).

Column (3) - National Stock Number. This is the NSN assigned to the item which you can use to requisition it.

Column (4) - Item Name, Description, Commercial and Government Entity Code (CAGE), and Part Number (P/N). This column provides the other information you need to identify the item.

Column (5) - Unit of Measure (U/M). This code shows the physical measurement or count of an item, such as gallon, dozen, gross, etc.

EXPENDABLE AND DURABLE ITEMS LIST

Table 0028 00-1. Expendable and Durable Items List

(1) ITEM NUMBER	(2) LEVEL	(3) NATIONAL STOCK NUMBER	(4) ITEM NAME, DESCRIPTION, CAGE, PART NUMBER	(5) U/M
1	C	6810-00-201-0906	Alcohol, denatured Grade III, 16 ounce bottle (81348) O-E-760	BT
2	C		Grease, Mobilux EP023	QT
3	C		Soap	
4	C	8020-00-224-8024	Brush, artist, MTL, ferrule, round tapered point. Type I, camel hair (81348) H-B-118	EA
5	C		Sealing Compound	QT
6	C		Paint, sand color (51489) P/N 700500-6	GL
7	C		Paint, camouflage pattern (51489) P/N 103994	GL

GLOSSARY

<u>Term</u>	<u>Definition</u>
2-Way Ventilator	Provides air circulation within the cargo bed cover.
Access Plate	When opened, allows electrical cables to be pushed through the opening to power equipment inside the cargo bed cover.
Cab Access Door	Allows for crawl-through space between the vehicle and the cargo bed cover.
Cable Boot	Opening channel in the cargo bed cover allowing cables to be pushed through and is opened or closed with the access plate.
Cargo Bed Cover (CBC)	A fiberglass enclosure that is mounted on a vehicle and is used to transport equipment.
CBC Shell	The cargo bed cover enclosure, including walls, ceiling and floor.
Chest Handle	Provides hand grips when climbing to the roof of the cargo bed cover.
Curb Side	Passenger side of CBC.
Folding Step	When extended, allows personnel to climb onto the roof of the cargo bed cover.
HMMWV	The High Mobility Multipurpose Wheeled Vehicle (HMMWV pronounced HUMVEE ®) for which the Type I cargo bed cover is designed.
Ladder	Used for climbing into the cargo bed cover.
Lanyard	Flexible strap that holds the access cover in place when it is open.
Lifting Ring	Used for attaching hoist when lifting cargo bed cover.
Lower Door Assembly	Provides a larger area to gain access to the cargo bed cover when latched together with the upper door assembly.

<u>Term</u>	<u>Definition</u>
Road Side	Driver side of CBC.
Rubber Strap	Strap on the storage access panel that keeps the panel closed when attached to the vehicle.
Storage Access Panel Assembly	Provides storage space for the HMMWV vehicle.
Upper Door Assembly	Allows rear access to the cargo bed cover.
Web Handles	Flexible handles permanently attached to the cab access door for opening or closing the door.

INDEX

<u>Subject</u>	<u>WP Sequence No.-Page No.</u>
A	
Assembly and Preparation for Use	0010 00-1
C	
Cleaning	0009 00-2
Controls.....	0005 00-1
Upper Door Assembly Latch	0005 00-2
Lower Door Assembly Latch	0005 00-2
2-Way Ventilator	0005 00-2
Folding Step	0005 00-2
Cab Access Door Handles	0005 00-2
Access Plate	0005 00-2
Components of End Item and Basic Issue Items.....	0027 00-1
E	
Emergency Procedures	0007 00-1
Equipment Data	0002 00-4
Expendable and Durable Items.....	0028 00-1
I	
Inspection.....	0009 00-1
Installation	0010 00-1
L	
Lubrication Intervals	0009 00-2
M	
Major Components	0002 00-3
Maintenance Allocation Chart	0023 00-1
O	
Operating Procedures.....	0006 00-1
Upper and Lower Doors.....	0006 00-1
Cab Access Door	0006 00-1
2-Way Ventilators	0006 00-1
Folding Steps	0006 00-1
P	
Preparation for Movement	0006 00-3
Preventive Maintenance Checks and Services	0009 00-3

<u>Subject</u>	<u>WP Sequence No.-Page No.</u>
R	
Remove	
Upper Door Assembly	0011 00-1
Door Holder.....	0012 00-1
Lower Door Assembly.....	0013 00-1
Cab Access Door	0014 00-1
Access Plate	0015 00-1
Storage Access Panel Assembly	0016 00-1
2-Way Ventilator	0017 00-1
Folding Step	0018 00-1
Chest Handle	0019 00-1
24-Inch Ladder	0020 00-1
References	0022 00-1
Repair Kit	0021 00-2
Repair Parts and Special Tools List	0024 00-1
Replace	
Upper Door Assembly	0011 00-2
Door Holder.....	0012 00-2
Lower Door Assembly	0013 00-2
Cab Access Door	0014 00-1
Access Plate	0015 00-2
Storage Access Panel Assembly	0016 00-2
2-Way Ventilator	0017 00-1
Folding Step	0018 00-1
Chest Handle	0019 00-1
24-Inch Ladder	0020 00-1
S	
Shell Assembly	
Minor Repair	0021 00-1
Major Damage Repair	0021 00-4
Lifting Ring Repair	0021 00-5
Interior Mounting Instructions	0021 00-6
Storage and Shipment	0010 00-4
T	
Theory of Operation	0003 00-1
Tools and Test Equipment Requirements	0023 00-6
Troubleshooting Procedures	0008 00-1
U	
Unpacking	0010 00-1
Unusual Environmental Conditions	0007 00-2

By Order of the Secretary of the Army:

Official:



JOEL B. HUDSON

*Administrative Assistant to the
Secretary of the Army*

0120001

ERIC K. SHINSEKI
*General, United States Army
Chief of Staff*

DISTRIBUTION:

To be distributed in accordance with initial distribution IDN 256681 requirements for
TM 10-5411-231-13&P.

These are the instructions for sending an electronic 2028

The following format must be used if submitting an electronic 2028. The subject line must be exactly the same and all fields must be included; however only the following fields are mandatory: 1, 3, 4, 5, 6, 7, 8, 9, 10, 13, 15, 16, 17, and 27.

From: "Whomever" <whomever@avma27.army.mil>
To: amssbriml@natick.army.mil

Subject: DA Form 2028

1. From: Joe Smith
2. Unit: home
3. Address: 4300 Park
4. City: Hometown
5. St: MO
6. Zip: 77777
7. Date Sent: 19-OCT-93
8. Pub no: 55-2840-229-23
9. Pub Title: TM
10. Publication Date: 04-JUL-85
11. Change Number: 7
12. Submitter Rank: MSG
13. Submitter FName: Joe
14. Submitter MName: T
15. Submitter LName: Smith
16. Submitter Phone: 123-123-1234
17. Problem: 1
18. Page: 2
19. Paragraph: 3
20. Line: 4
21. NSN: 5
22. Reference: 6
23. Figure: 7
24. Table: 8
25. Item: 9
26. Total: 123
27. Text:

This is the text for the problem below line 27.

RECOMMENDED CHANGES TO PUBLICATIONS AND BLANK FORMS For use of this form, see AR 25-30; the proponent agency is ODISC4.						Use Part II (reverse) for Repair Parts and Special Tool Lists (RPSTL) and Supply Catalogs/Supply Manuals (SC/SM).	DATE 21 October 2003
TO: (Forward to proponent of publication or form) (Include ZIP Code) COMMANDER U.S. ARMY TANK-AUTOMOTIVE AND ARMAMENT COMMAND ATTN: AMSTA-LC-CECT 15 KANSAS STREET NATICK, MA 01760-5052						FROM: (Activity and location) (Include ZIP Code) <i>PFC Jane Doe</i> <i>CO A 3rd Engineer BR</i> <i>Ft. Leonardwood, MO 63108</i>	
PART I – ALL PUBLICATIONS (EXCEPT RPSTL AND SC/SM) AND BLANK FORMS							
PUBLICATION/FORM NUMBER TM 10-1670-296-23&P				DATE 30 October 2002	TITLE Unit Manual for Ancillary Equipment for Low Velocity Air Drop Systems		
ITEM NO.	PAGE NO.	PARA-GRAPH	LINE NO. *	FIGURE NO.	TABLE NO.	RECOMMENDED CHANGES AND REASON <i>(Provide exact wording of recommended changes, if possible).</i>	
	0036 00-2				1	<i>In table 1, Sewing Machine Code Symbols, the second sewing machine code symbol should be MD ZZ not MD 22.</i> <i>Change the manual to show Sewing Machine, Industrial: Zig-Zag; 308 stitch; medium-duty; NSN 3530-01-181-1421 as a MD ZZ code symbol.</i>	
<small>*Reference to line numbers within the paragraph or subparagraph.</small>							
TYPED NAME, GRADE OR TITLE Jane Doe, PFC				TELEPHONE EXCHANGE/AUTOVON, PLUS EXTENSION 508-233-4141		SIGNATURE Jane Doe <i>Jane Doe</i>	

TO: <i>(Forward direct to addressee listed in publication)</i> COMMANDER U.S. ARMY TANK-AUTOMOTIVE AND ARMAMENT COMMAND ATTN: AMSTA-LC-CECT 15 KANSAS STREET NATICK, MA 01760-5052	FROM: <i>(Activity and location) (Include ZIP Code)</i> <i>PFC Jane Doe</i> <i>CO A 3rd Engineer BR</i> <i>Ft. Leonardwood, MO 63108</i>	DATE 21 October 2003
--	---	--------------------------------

PART II – REPAIR PARTS AND SPECIAL TOOL LISTS AND SUPPLY CATALOGS/SUPPLY MANUALS

PUBLICATION NUMBER TM 10-1670-296-23&P	DATE 30 October 2002	TITLE Unit Manual for Ancillary Equipment for Low Velocity Air Drop Systems
--	--------------------------------	---

PAGE NO.	COLM NO.	LINE NO.	NATIONAL STOCK NUMBER	REFERENCE NO.	FIGURE NO.	ITEM NO.	TOTAL NO. OF MAJOR ITEMS SUPPORTED	RECOMMENDED ACTION
0066 00-1					4			<i>Callout 16 in figure 4 is pointed to a <u>D-Ring</u>. In the Repair Parts List key for figure 4, item 16 is called a <u>Snap Hook</u>. Please correct one or the other.</i>

SAMPLE

PART III – REMARKS *(Any general remarks or recommendations, or suggestions for improvement of publications and blank forms. Additional blank sheets may be used if more space is needed.)*

TYPED NAME, GRADE OR TITLE	TELEPHONE EXCHANGE/AUTOVON, PLUS EXTENSION	SIGNATURE
----------------------------	--	-----------

<p align="center">RECOMMENDED CHANGES TO PUBLICATIONS AND BLANK FORMS</p> <p>For use of this form, see AR 25-30; the proponent agency is ODISC4.</p>						Use Part II (reverse) for Repair Parts and Special Tool Lists (RPSTL) and Supply Catalogs/Supply Manuals (SC/SM).	DATE
TO: (Forward to proponent of publication or form) (Include ZIP Code) COMMANDER U.S. ARMY TANK-AUTOMOTIVE AND ARMAMENT COMMAND ATTN: AMSTA-LC-CECT 15 KANSAS STREET NATICK, MA 01760-5052						FROM: (Activity and location) (Include ZIP Code)	
PART I – ALL PUBLICATIONS (EXCEPT RPSTL AND SC/SM) AND BLANK FORMS							
PUBLICATION/FORM NUMBER TM 10-5411-231-13&P						DATE 1 August 2001	TITLE Operator's, Unit, and Direct Support Maintenance Manual Including Repair Parts and Special Tools List (RPSTL) for Cargo Bed Cover (CBC) HMMWV, Type I
ITEM NO.	PAGE NO.	PARA-GRAPH	LINE NO. *	FIGURE NO.	TABLE NO.	RECOMMENDED CHANGES AND REASON <i>(Provide exact wording of recommended changes, if possible).</i>	
*Reference to line numbers within the paragraph or subparagraph.							
TYPED NAME, GRADE OR TITLE				TELEPHONE EXCHANGE/AUTOVON, PLUS EXTENSION		SIGNATURE	

TO: <i>(Forward direct to addressee listed in publication)</i> COMMANDER U.S. ARMY TANK-AUTOMOTIVE AND ARMAMENT COMMAND ATTN: AMSTA-LC-CECT 15 KANSAS STREET NATICK, MA 01760-5052	FROM: <i>(Activity and location) (Include ZIP Code)</i>	DATE
--	--	-------------

PART II – REPAIR PARTS AND SPECIAL TOOL LISTS AND SUPPLY CATALOGS/SUPPLY MANUALS

PUBLICATION NUMBER TM 10-5411-231-13&P	DATE 1 August 2001	TITLE Operator's, Unit, and Direct Support Maintenance Manual Including Repair Parts and Special Tools List (RPSTL) for Cargo Bed Cover (CBC) HMMWV, Type I
---	-----------------------	--

PAGE NO.	COLM NO.	LINE NO.	NATIONAL STOCK NUMBER	REFERENCE NO.	FIGURE NO.	ITEM NO.	TOTAL NO. OF MAJOR ITEMS SUPPORTED	RECOMMENDED ACTION

PART III – REMARKS *(Any general remarks or recommendations, or suggestions for improvement of publications and blank forms. Additional blank sheets may be used if more space is needed.)*

TYPED NAME, GRADE OR TITLE	TELEPHONE EXCHANGE/AUTOVON, PLUS EXTENSION	SIGNATURE
----------------------------	--	-----------

<p align="center">RECOMMENDED CHANGES TO PUBLICATIONS AND BLANK FORMS</p> <p>For use of this form, see AR 25-30; the proponent agency is ODISC4.</p>						Use Part II (reverse) for Repair Parts and Special Tool Lists (RPSTL) and Supply Catalogs/Supply Manuals (SC/SM).	DATE
TO: (Forward to proponent of publication or form) (Include ZIP Code) COMMANDER U.S. ARMY TANK-AUTOMOTIVE AND ARMAMENT COMMAND ATTN: AMSTA-LC-CECT 15 KANSAS STREET NATICK, MA 01760-5052						FROM: (Activity and location) (Include ZIP Code)	
PART I – ALL PUBLICATIONS (EXCEPT RPSTL AND SC/SM) AND BLANK FORMS							
PUBLICATION/FORM NUMBER TM 10-5411-231-13&P						DATE 1 August 2001	TITLE Operator's, Unit, and Direct Support Maintenance Manual Including Repair Parts and Special Tools List (RPSTL) for Cargo Bed Cover (CBC) HMMWV, Type I
ITEM NO.	PAGE NO.	PARA-GRAPH	LINE NO. *	FIGURE NO.	TABLE NO.	RECOMMENDED CHANGES AND REASON <i>(Provide exact wording of recommended changes, if possible).</i>	
*Reference to line numbers within the paragraph or subparagraph.							
TYPED NAME, GRADE OR TITLE				TELEPHONE EXCHANGE/AUTOVON, PLUS EXTENSION		SIGNATURE	

TO: <i>(Forward direct to addressee listed in publication)</i> COMMANDER U.S. ARMY TANK-AUTOMOTIVE AND ARMAMENT COMMAND ATTN: AMSTA-LC-CECT 15 KANSAS STREET NATICK, MA 01760-5052	FROM: <i>(Activity and location) (Include ZIP Code)</i>	DATE
--	--	-------------

PART II – REPAIR PARTS AND SPECIAL TOOL LISTS AND SUPPLY CATALOGS/SUPPLY MANUALS

PUBLICATION NUMBER TM 10-5411-231-13&P	DATE 1 August 2001	TITLE Operator's, Unit, and Direct Support Maintenance Manual Including Repair Parts and Special Tools List (RPSTL) for Cargo Bed Cover (CBC) HMMWV, Type I
---	-----------------------	--

PAGE NO.	COLM NO.	LINE NO.	NATIONAL STOCK NUMBER	REFERENCE NO.	FIGURE NO.	ITEM NO.	TOTAL NO. OF MAJOR ITEMS SUPPORTED	RECOMMENDED ACTION

PART III – REMARKS *(Any general remarks or recommendations, or suggestions for improvement of publications and blank forms. Additional blank sheets may be used if more space is needed.)*

TYPED NAME, GRADE OR TITLE	TELEPHONE EXCHANGE/AUTOVON, PLUS EXTENSION	SIGNATURE
----------------------------	--	-----------

The Metric System and Equivalents

Linear Measure

1 centimeter = 10 millimeters = .39 inch
 1 decimeter = 10 centimeters = 3.94 inches
 1 meter = 10 decimeters = 39.37 inches
 1 dekameter = 10 meters = 32.8 feet
 1 hectometer = 10 dekameters = 328.08 feet
 1 kilometer = 10 hectometers = 3,280.8 feet

Weights

1 centigram = 10 milligrams = .15 grain
 1 decigram = 10 centigrams = 1.54 grains
 1 gram = 10 decigrams = .035 ounce
 1 dekagram = 10 grams = .35 ounce
 1 hectogram = 10 dekagrams = 3.52 ounces
 1 kilogram = 10 hectograms = 2.2 pounds
 1 quintal = 100 kilograms = 220.46 pounds
 1 metric ton = 10 quintals = 1.1 short tons

Liquid Measure

1 centiliter = 10 milliliters = .34 fl. ounce
 1 deciliter = 10 centiliters = 3.38 fl. ounces
 1 liter = 10 deciliters = 33.81 fl. ounces
 1 dekaliter = 10 liters = 2.64 gallons
 1 hectoliter = 10 dekaliters = 26.42 gallons
 1 kiloliter = 10 hectoliters = 264.18 gallons

Square Measure

1 sq. centimeter = 100 sq. millimeters = .155 sq. inch
 1 sq. decimeter = 100 sq. centimeters = 15.5 sq. inches
 1 sq. meter (centare) = 100 sq. decimeters = 10.76 sq. feet
 1 sq. dekameter (are) = 100 sq. meters = 1,076.4 sq. feet
 1 sq. hectometer (hectare) = 100 sq. dekameters = 2.47 acres
 1 sq. kilometer = 100 sq. hectometers = .386 sq. mile

Cubic Measure

1 cu. centimeter = 1000 cu. millimeters = .06 cu. inch
 1 cu. decimeter = 1000 cu. centimeters = 61.02 cu. inches
 1 cu. meter = 1000 cu. decimeters = 35.31 feet

Approximate Conversion Factors

<i>To change</i>	<i>To</i>	<i>Multiply by</i>	<i>To change</i>	<i>To</i>	<i>Multiply by</i>
inches	centimeters	2.540	ounce-inches	newton-meters	.007062
feet	meters	.305	centimeters	inches	.394
yards	meters	.914	meters	feet	3.280
miles	kilometers	1.609	meters	yards	1.094
square inches	square centimeters	6.451	kilometers	miles	.621
square feet	square meters	.093	square centimeters	square inches	.155
square yards	square meters	.836	square meters	square feet	10.764
square miles	square kilometers	2.590	square meters	square yards	1.196
acres	square hectometers	.405	square kilometers	square miles	.386
cubic feet	cubic meters	.028	square hectometers	acres	2.471
cubic yards	cubic meters	.765	cubic meters	cubic feet	35.315
fluid ounces	milliliters	29.573	cubic meters	cubic yards	1.308
pints	liters	.473	milliliters	fluid ounces	.034
quarts	liters	.946	liters	pints	2.113
gallons	liters	3.785	liters	quarts	1.057
ounces	grams	28.349	liters	gallons	.264
pounds	kilograms	.454	grams	ounces	.035
short tons	metric tons	.907	kilograms	pounds	2.205
pound-feet	newton-meters	1.356	metric tons	short tons	1.102
pound-inches	newton-meters	.11296			

Temperature (Exact)

_F	Fahrenheit temperature	5/9 (after subtracting 32)	Celsius temperature	_C
----	---------------------------	-------------------------------	------------------------	----

PIN: 079151-000