

TM 11-7440-293-14

TECHNICAL MANUAL

**OPERATOR'S, ORGANIZATIONAL, DIRECT
SUPPORT, AND GENERAL SUPPORT
MAINTENANCE**

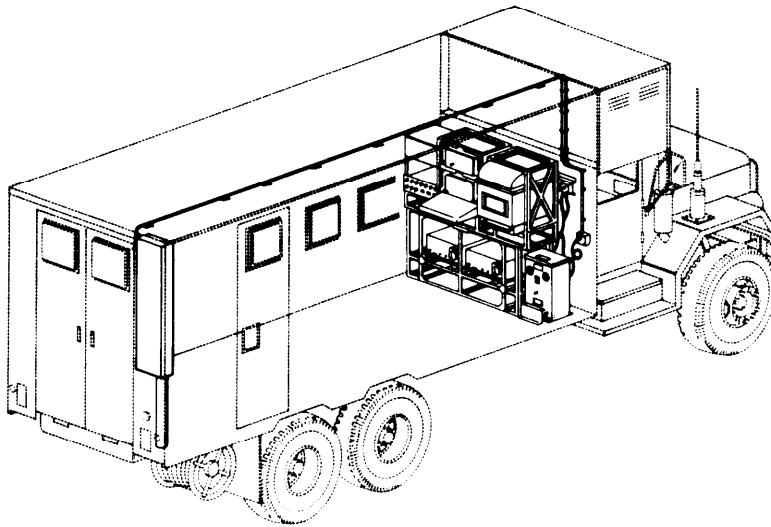

**EQUIPMENT
DESCRIPTION**

1-5

**ASSEMBLY AND
INSTALLATION**

4-4

**REMOVAL OF
EQUIPMENT**

4-121

INDEX

Index 1

**ELECTRONICS EQUIPMENT INSTALLATION
KIT MK-1818/GSG-10(V)
(NSN 1290-01-070-8908)
FOR
5-TON EXPANSIBLE VAN TRUCK M820**

**HEADQUARTERS, DEPARTMENT OF THE ARMY
JUNE 1983**



5

SAFETY STEPS TO FOLLOW IF SOMEONE IS THE VICTIM OF ELECTRICAL SHOCK

1

DO NOT TRY TO PULL OR GRAB THE INDIVIDUAL

2

IF POSSIBLE, TURN OFF THE ELECTRICAL POWER

3

IF YOU CANNOT TURN OFF THE ELECTRICAL POWER, PULL, PUSH, OR LIFT THE PERSON TO SAFETY USING A WOODEN POLE OR A ROPE OR SOME OTHER INSULATING MATERIAL

4

SEND FOR HELP AS SOON AS POSSIBLE

5

AFTER THE INJURED PERSON IS FREE OF CONTACT WITH THE SOURCE OF ELECTRICAL SHOCK, MOVE THE PERSON A SHORT DISTANCE AWAY AND IMMEDIATELY START ARTIFICIAL RESUSCITATION

WARNING

HIGH VOLTAGE

is used in the operation of this equipment.

DEATH ON CONTACT

may result if personnel fail to observe
safety precautions.

Never work on electronic equipment unless there is another person nearby who is familiar with the operation and hazards of the equipment. When the technician is aided by an operator they must warn the operator about dangerous areas.

The power supply must be shut off before beginning work on the equipment. Always ground every part before touching it. When possible, keep one hand away from equipment to reduce the hazard of electrical shock.

Be sure equipment is always properly grounded.

When performing work on a vehicle always engage parking brake.

—

.

—

TECHNICAL MANUAL
No. 11-7440-293-14

HEADQUARTERS
DEPARTMENT OF THE ARMY
Washington, DC, 15 June 1983

**Operator's, Organizational,
Direct Support, and General Support
Maintenance Manual**

**ELECTRONICS EQUIPMENT INSTALLATION KIT MK-1818/GSG-10(V)
(NSN 1290-01-070-8908)**

5-TON EXPANSIBLE VAN TRUCK M820

REPORTING ERRORS AND RECOMMENDING IMPROVEMENTS

You can help improve this manual. If you find any mistakes or if you know of a way to improve the procedures, please let us know. Mail your letter or DA Form 2028 (Recommended Changes to Equipment Publications and Blank Forms) or DA Form 2028-2 located in the back of this manual direct to: Commander, US Army Communications-Electronics Command and Fort Monmouth, ATTN: DRSEL-ME-MP, Fort Monmouth, New Jersey 07703. A reply will be furnished to you.

Page

	HOW TO USE THIS MANUAL	ii
CHAPTER 1	INTRODUCTION	1-1
Section I	General Information	1-1
Section II	Equipment Description	1-5
Section III	Principles of operation	1-8
CHAPTER 2	OPERATING INSTRUCTIONS	2-1
Section I	Description and Use of Operator's Controls and Indicators	2-1
Section II	Operator Preventive Maintenance Checks and Services	2-1
Section III	Operation Under Usual Conditions	2-1
Section IV	Operation Under Unusual Conditions	2-1
CHAPTER 3	OPERATOR MAINTENANCE	3-1
Section I	Lubrication Instructions	3-1
Section II	Troubleshooting Procedures	3-1
Section III	Maintenance Procedures	3-1

	Page
CHAPTER 4	ORGANIZATIONAL MAINTENANCE 4-1
Section I	Repair Parts, Special Tools, TMDE, and Support Equipment. 4-1
Section II	Service Upon Receipt 4-1
Section III	Assembly and Installation of Electronics Equipment installation Kit 4-4
Section IV	Preventive Maintenance Checks and Services. 4-120
Section V	Troubleshooting Procedures 4-120
Section VI	Maintenance Procedures 4-120
Section VII	Removal of Electronics Equipment Kit MK-1818/GSG-10(V) 4-121
Section VIII	Preparation for Storage and Shipment 4-194
CHAPTER 5	DIRECT SUPPORT AND GENERAL SUPPORT MAINTENANCE. 5-1
APPENDIX A	REFERENCES A-1
APPENDIX B	MAINTENANCE ALLOCATION CHART B-1
GLOSSARY Glossary 1
INDEX Index 1

HOW TO USE THIS MANUAL

In this manual, paragraphs are numbered by chapter and order in each chapter. To find the paragraph you need, first locate your subject in the table of contents. Turn to the page shown and read the paragraph headings until you see what you're looking for. If you find a word or term you don't understand, refer to the glossary in the back of the book.

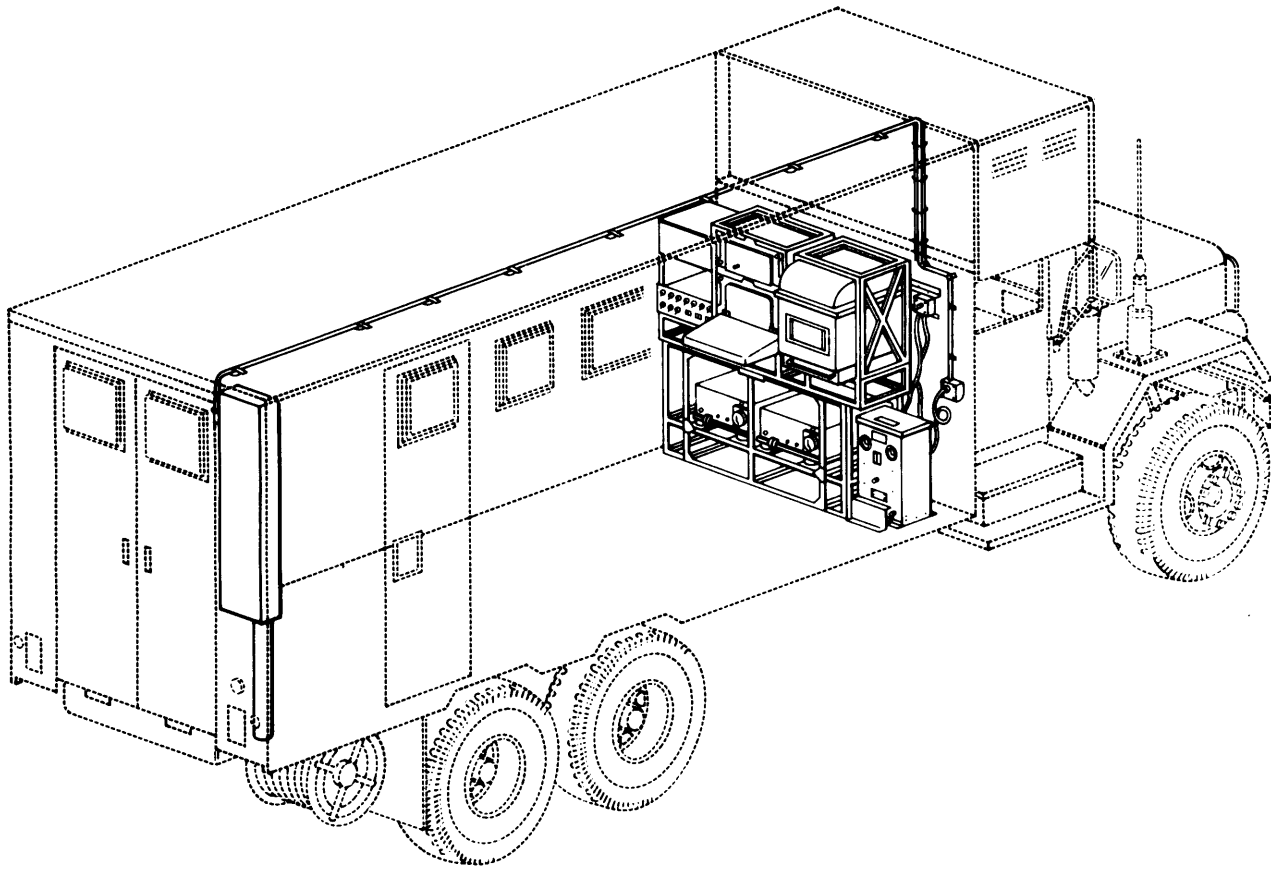

TACFIRE INSTALLED IN 5-TON EXPANSIBLE VAN TRUCK M820

EL8KD001

CHAPTER 1

INTRODUCTION

Subject	Section	Page
General Information	I	1-1
Equipment Description	II	1-5
Principles of Operation	III	1-8

OVERVIEW

This chapter contains general information, equipment descriptions, and principles of operation for Electronics Equipment installation Kit MK-1818/GSG-10(V) in truck, van (expandible) 5-ton M820.

Section I GENERAL INFORMATION

Subject	Para	Page
Scope	1-1	1-1
Maintenance Forms,Records, and Reports	1-2	1-1
Destruction of Army Electronics Materiel to Prevent Enemy Use	1-3	1-2
Administrative Storage	1-4	1-2
Reporting Equipment Improvement Recommendations	1-5	1-2
Nomenclature Cross-Reference List	1-6	1-2
List of Abbreviations	1-7	1-4

1-1. SCOPE.

Type of Manual: Operator's, Organizational, Direct Support, and General Support Maintenance.

Model Number and Equipment Name: MK-1818/GSG-10(V) Installation Kit, Electronic Equipment in Truck, Van (Expandible) 5-Ton M820.

Purpose of Equipment: Provides mounting racks, hardware and cables for the installation of Variable Format Message Entry Device AN/GSC-21 in truck, van (expandible) 5-ton M820.

1-2. MAINTENANCE FORMS, RECORDS, AND REPORTS.

REPORTS OF MAINTENANCE AND UNSATISFACTORY EQUIPMENT

Department of the Army forms and procedures used for equipment maintenance will be those prescribed by TM 38-750, The Army Maintenance Management System (TAMMS).

REPORT OF PACKAGING AND HANDLING DEFICIENCIES

Fill out and forward SF 364, Report of Discrepancy (ROD) as prescribed in AR 735-11-2/DLAR 4140.55/NAVMATINST 4355.73/AFR 400-54/MCO 4430.3E.

1-2. MAINTENANCE FORMS, RECORDS, AND REPORTS. (CONT)

Fill out and forward Discrepancy in Shipment Report (DISREP) (SF 361) as prescribed in AR 55-38/ NAVSUPINST 4610.33 B/AFR 75-18/MCO 4610.19 C/DLAR 4500.15.

1-3. DESTRUCTION OF ARMY ELECTRONICS MATERIEL TO PREVENT ENEMY USE.

Destruction of Army electronics materiel to prevent enemy use shall be in accordance with TM 750-244-2.

1-4. ADMINISTRATIVE STORAGE.

Administrative storage of equipment issued to and used by Army activities will have preventive maintenance performed in accordance with the PMCS charts before storing. When removing the equipment from administrative storage, the PMCS should be performed to assure operational readiness. Disassembly and repacking of equipment for shipment or limited storage are covered in Chapter 4.

1-5. REPORTING EQUIPMENT IMPROVEMENT RECOMMENDATIONS (EIR).

If your Electronics Equipment Installation Kit MK-1818/GSG-10(V) needs improvement, let us know. Send us an EIR. You, the user, are the only one who can tell us what you don't like about your equipment. Let us know why you don't like the design. Put it on an SF 368 (Quality Deficiency Report). Mail it to: Commander, US Army Communications-Electronics Command and Fort Monmouth, ATTN: DRSEL-ME-MP, Fort Monmouth, New Jersey 07703. We'll send you a reply.

1-6. NOMENCLATURE CROSS-REFERENCE LIST.

This list contains common names used throughout this manual in place of official nomenclature.

Common Name	Official Nomenclature
antenna mount assembly	Antenna Assembly AS-1729/URC and antenna mount
curbside antenna cables	Curbside Antenna Lead-in Cable Assembly RF CX-1773B/U (20 ft) and SP CX-4722/VRC (20 ft)
dc/dc switch	switch assembly, dc/dc
distribution box	Distribution Box J-3030/GSG-10(V)
electronic line printer rack	Electrical Equipment Rack MT-4392/GSG-10(V)
electronic equipment	message entry device, electronic line printer, key generator, power distribution box

1-6. NOMENCLATURE CROSS-REFERENCE LIST. (CONT)

Common Name	Official Nomenclature
electronic equipment racks	key generator rack, message entry device rack, electronic line printer rack
Hubbell connector plug	connector, plug, 3 phase, 3 wire, 30 amp, Hubbell #3331-C
installation kit	Electronics Equipment Installation Kit MK-1818/GSG-10(V)
key generator rack	Electrical Equipment Rack MT-4393/GSG-10(V)
message entry group rack	Electrical Equipment Rack MT-4391/GSG-10(V)
power cable	Cable, 3 Cord, No. 10, Type C0-03 M0F (3/10) 0690 (26 ft)
power distribution box	Power Distribution Box J-3030/GSG-10(V)
power supply	Power Supply, PP-1104/G, 50 amp, 24 v
radio mount	Radio Mount MT-4395/GSG-10(V)
radio mounting base	Radio Mounting Base MT-1029/VRC
receptacle	receptacle, 3 phase, 3 wire, 30 amp Hubbell #3330
roadside antenna cables	Roadside Antenna Lead-in Cable Assembly RF CX-1773B/U (20 ft) and CX-4722/VRC (20 ft)
table mount	Electronic Equipment Table MT-4394/GSG-10(V)
tacfire mount	assembled racks to hold electronic equipment
tacfire rack	assembled racks
wall support	wall mount assembly
30 inch ground strap	electrical lead (30 in.)

1-7. LIST OF ABBREVIATIONS.

This list contains abbreviations used in this manual.

Abbreviation	Word or Term
IT	internal tooth
IET	internal/external tooth
tacfire	tactical firing equipment
rf	radio frequency
sp	special purpose

Section II EQUIPMENT DESCRIPTION

Subject	Para	Page
Purpose of Installation Kit	1-8	1-5
Equipment Capabilities and Features	1-9	1-5
Location and Description of Major Components.	1-10	1-8
Safety, Care, and Handling	1-11	1-8

1-8. PURPOSE OF INSTALLATION KIT.

The installation kit provides:

- Mounting Racks
- Antennas
- Power Connections for Electronic Equipment

1-9. EQUIPMENT CAPABILITIES AND FEATURES.

- Can be operated in all weather and climate conditions.
- Fully transportable and mobile.
- Secure field and teletype communications.

1-10. LOCATION AND DESCRIPTION OF MAJOR COMPONENTS.

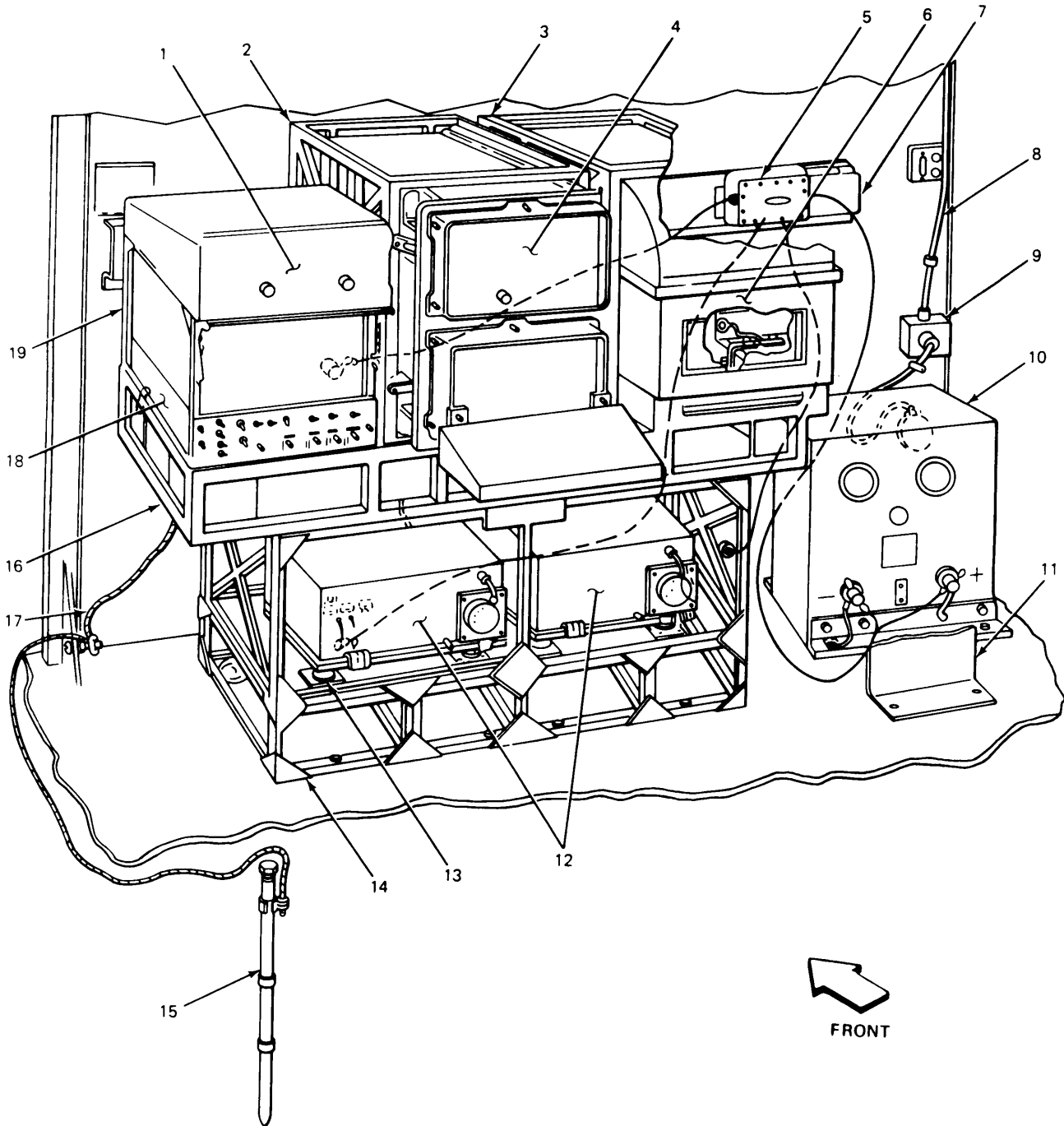

EL8KD002

1.10. LOCATION AND DESCRIPTION OF MAJOR COMPONENTS. (CONT)

FORWARD WALL

- 1 KEY GENERATOR. Communications security equipment.
- 2 MESSAGE ENTRY GROUP RACK. Provides a housing and support for message entry group.
- 3 ELECTRONIC LINE PRINTER RACK. Provides a housing and support for electronic line printer.
- 4 MESSAGE ENTRY GROUP. Groups incoming messages to produce a word or words.
- 5 DC/DC SWITCH. Switches power source.
- 6 ELECTRONIC LINE PRINTER. Teletypewriter.
- 7 WALL SUPPORT. Provides rear support for tacfire rack.
- 8 POWER CABLE. Routes power from circuit breaker box to power supply.
- 9 4 x 4-INCH OUTLET BOX. Provides an outlet or electrical connection for power supply.
- 10 POWER SUPPLY. Supplies power by converting alternating current to direct current.
- 11 GUARD ASSEMBLY. Provides protection from electrical shock by shielding exposed connections in front of power supply.
- 12 RADIO RECEIVER TRANSMITTER. Receives and transmits radio signals.
- 13 RADIO MOUNTING BASES MT-1029/VRC. Supports radio receiver transmitters.
- 14 RADIO MOUNT. Provides a base support for tacfire rack and serves as a housing and support for radio receiver transmitters.
- 15 EXTERNAL GROUNDING ROD. Provides an external ground for electronic equipment.
- 16 ELECTRONIC EQUIPMENT TABLE. Provides a mount and support for electronic equipment racks.
- 17 30-INCH GROUNDING STRAP. Provides a ground to truck body for the electronic equipment.
- 18 POWER DISTRIBUTION BOX. Distributes input power to electronic equipment.
- 19 KEY GENERATOR RACK. Provides a housing and support for key generator and power distribution box.

1-10. LOCATION AND DESCRIPTION OF MAJOR COMPONENTS. (CONT)

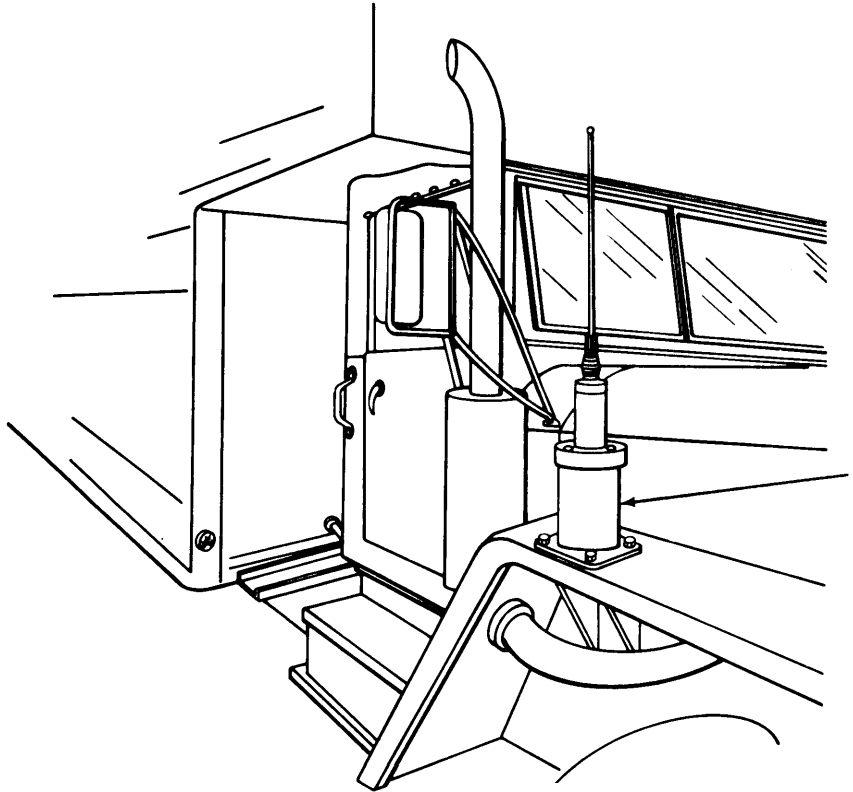

EL8KD003

TOP OF CURBSIDE AND ROADSIDE FENDERS

- 1 ANTENNA MOUNT ASSEMBLIES. Provides a mounting base for the antennas.

1-11. SAFETY, CARE, AND HANDLING.

Be sure to obey all WARNINGS and CAUTIONS given in this manual. Serious injury to personnel or damage to equipment may result if WARNINGS and CAUTIONS are not followed exactly.

Section III PRINCIPLES OF OPERATION

OVERVIEW

Refer to TM 11-7440-251-10 and TM 11-7440-253-10-1 for principles of operation for the electronic equipment housed in the installation kit.

CHAPTER 2

OPERATING INSTRUCTIONS

Subject	Section	Page
Description and Use of Operator's Controls and Indicators	I	2-1
Operator Preventive Maintenance Checks and Services	II	2-1
Operation Under Usual Conditions	III	2-1
Operation Under Unusual Conditions.	IV	2-1

OVERVIEW

This chapter contains description and use of operator's controls and indicators and operator preventive maintenance checks and services for the electronic equipment provided in the installation kit.

Section I DESCRIPTION AND USE OF OPERATOR'S CONTROLS AND INDICATORS

Subject	Para	Page
Operating Instructions	2-1	2-1

2-1. OPERATING INSTRUCTIONS.

For operating instructions of the tacfire electronic equipment refer to TM 11-7440-251-10 and TM 11-7440-253-10-1.

Section II OPERATOR PREVENTIVE MAINTENANCE CHECKS AND SERVICES

There are no operator PMCS procedures for this equipment. Routine checks like equipment inventory, cleaning the vehicle, checking for trayed or broken cables, replacing items not in use, and checking for loose hardware, such as nuts, bolts and screws are not listed in the PMCS table. Do these tasks anytime you see they need to be done.

Section III OPERATION UNDER USUAL CONDITIONS

For operation under usual conditions refer to TM 11-7440-251-10 and TM 11-7440-253-10-1.

Section IV OPERATION UNDER UNUSUAL CONDITIONS

For operation under unusual conditions refer to TM 11-7440-251-10 and TM 11-7440-253-10-1.

CHAPTER 3 OPERATOR MAINTENANCE

Subject	Section	Page
Lubrication Instructions	I	3-1
Troubleshooting Procedures	II	3-1
Maintenance Procedures	III	3-1

OVERVIEW

This chapter contains lubrication, troubleshooting and maintenance instructions for the electronic equipment in the installation kit.

Section I LUBRICATION INSTRUCTIONS

There are no lubrication instructions for Installation Kit MK-1818-GSG-10(V) in truck, van (expandable) 5-ton M820.

Section II TROUBLESHOOTING PROCEDURES

For troubleshooting procedures refer to TM 11-7440-251-10 and TM 11-7440-253-10-1.

Section III MAINTENANCE PROCEDURES

For maintenance procedures refer to TM 11-7440-251-10 and TM 7440-253-10-1.

CHAPTER 4

ORGANIZATIONAL MAINTENANCE

Subject	Section	Page
Repair Parts, Special Tools, TMDE, and Support Equipment	I	4-1
Service Upon Receipt.	II	4-1
Assembly and Installation of Electronics Equipment Kit	III	4-4
Preventive Maintenance Checks and Services	IV	4-120
Organizational Troubleshooting	V	4-120
Maintenance Procedures	VI	4-120
Removal of Electronics Equipment Kit.	VII	4-121

OVERVIEW

This chapter contains instructions for the assembly, installation and removal of the installation kit.

Section I REPAIR PARTS, SPECIAL TOOLS, TMDE, AND SUPPORT EQUIPMENT

Subject	Para	Page
Common Tools and Equipment	4-1	4-1
Special Tools, TMDE, and Support Equipment	4-2	4-1

4-1. COMMON TOOLS AND EQUIPMENT.

The common tools and equipment needed for the installation of the electronic equipment installation kit will be listed in the Maintenance Allocation Chart found in appendix B, and at the beginning of each installation procedure.

4-2. SPECIAL TOOLS, TMDE, AND SUPPORT EQUIPMENT.

Refer to appendix B for special tools required for installation of electronic equipment installation kit.

Section II SERVICE UPON RECEIPT

Subject	Para	Page
Unpacking	4-3	4-2
Checking Unpacked Materiel	4-4	4-4

4-3. UNPACKING.

This task covers:

Unpacking

INITIAL SETUP

Tools	Personnel Required
Pliers Nail puller Shears Pocket knife	One mechanic Equipment Condition Equipment crated.
Materials/Parts	
None	

LOCATION	ITEM	ACTION REMARKS
----------	------	-------------------

WARNING

Stand to side of each packing band when cutting.

NOTE

Move crated equipment to site of installation. Save cartons, fillers, and blocking for future use as packing for storage.

1. Wooden crate	Packing band (1)	Using shears, cut.
2. Top cover	Nails (2)	Using nail puller, remove.
3. Wooden crate	Top cover (3)	Remove.
4. Side cover	Nails (4)	Using nail puller, remove.
5. Wooden crate	Side cover (5)	Remove. If packed for overseas, remove moisture proof cover.

NOTE

Remove cartons from crate and carefully remove components. Some parts are secured to sides of wooden crate. Using pliers, remove.

4-3. UNPACKING. (CONT)

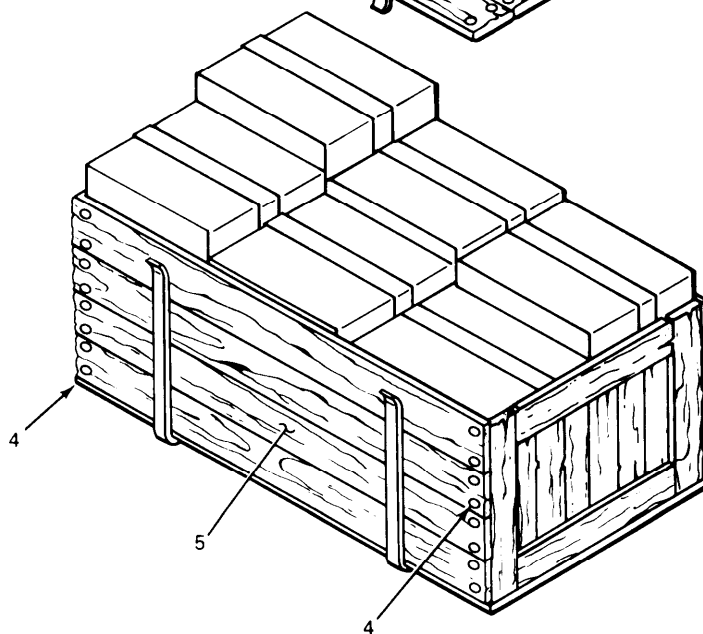
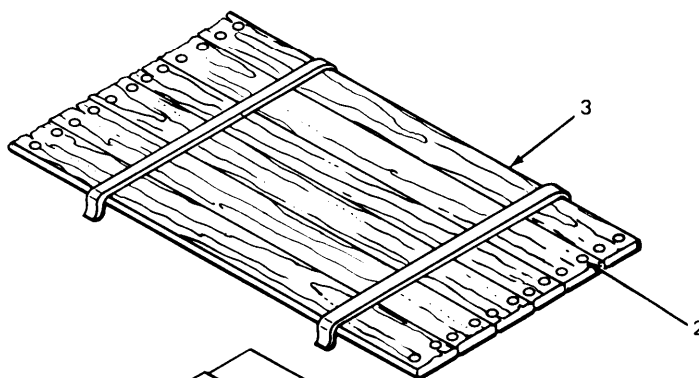
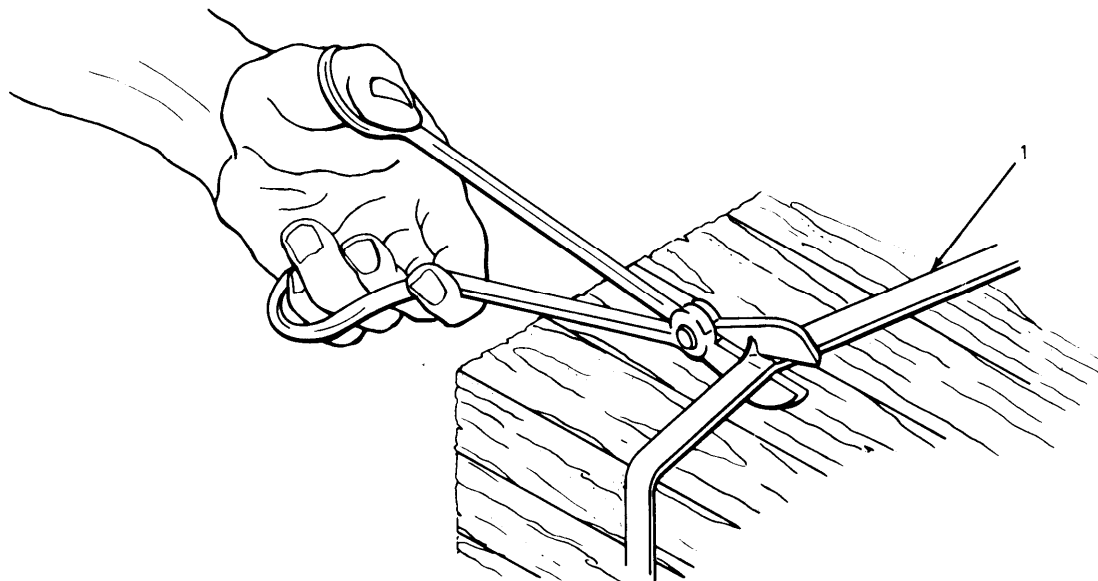

EL8KD004

4-4. CHECKING UNPACKED MATERIEL.

When the installation kit is received, the unpacker must check equipment for damage resulting from shipment, proper amount of items or parts shipped, and if the right units were sent in the kit.

If damage to a unit or a part of the kit other than minor scratches or dents are found, refer to paragraph 1-2, Maintenance Forms, Records and Reports. Check the parts list with the parts received and if there is a difference in the amount received, report on forms shown in TM 38-750. If the part numbers are not the same, check the current Modification Work Order (MWO) DA Pam 310-1 for a change in parts listing.

**Section III ASSEMBLY AND INSTALLATION OF ELECTRONICS EQUIPMENT
INSTALLATION KIT**

Subject	Para	
Tacfire Rack	4-5	4-6
Installing Electronic Equipment Table to Radio Mount	4-6	4-6
Installing Key Generator Rack to Electronic Equipment Table	4-7	4-8
Installing Message Entry Group Rack to Electronic Equipment Table	4-8	4-10
Installing Electronic Line Printer Rack to Electronic Equipment Table	4-9	4-12
Installing Wall Support to Tacfire Rack	4-10	4-14
Installing 4-inch Ground Straps	4-11	4-16
Installing Angle Brackets on PP-1104 Power Supply.	4-12	4-18
Installing Angle Brackets on PP-4763 Power Supply.	4-13	4-20
Preparation for Drilling	4-14	4-22
Tacfire Rack Mounting Holes	4-15	4-22
PP-1104 Power Supply and Guard Assembly Mounting Holes	4-16	4-24
PP-4763 Power Supply Mounting Holes	4-17	4-26
Pipe Nipple and 30-inch Ground Strap Mounting Holes	4-18	4-28
Cable Connector Mounting Hole	4-19	4-30
Curbside Antenna Cable Mounting Holes	4-20	4-32
Roadside Antenna Cable Mounting Holes	4-21	4-34
Center Punching Marks	4-22	4-36
Drilling Instructions	4-23	4-40
Pilot Drilling Marks	4-24	4-40
Drilling Forward Area of Truck	4-25	4-44
Drilling for Flush Mounting of Rivnuts	4-26	4-46
Drilling 90° Cable Connector Hole	4-27	4-48
Installing Rivnuts.	4-28	4-50
Installing Pipe Nipple	4-29	4-54
Installing Tacfire Rack.	4-30	4-56
Installing Radio Mounting Base MT-1029/VRC.	4-31	4-58
Installing Tacfire Components	4-32	4-60
DC/DC Switch.	4-33	4-62
Installing DC/DC Switch	4-34	4-62
DC/DC Switch Routing of Cables	4-35	4-64
Installing 30-inch Ground Strap	4-36	4-66
Curbside Antenna Mount.	4-37	4-68
Installing Antenna Assembly AS-1729/VRC to Antenna Mount	4-38	4-68
Installing Curbside Antenna Mount Assembly	4-39	4-72

Subject	Para	Page
Routing Curbside Antenna Cable	4-40	4-74
Installing Curbside Antenna Cables	4-41	4-76
Roadside Antenna Mount	4-42	4-78
Installing Antenna Assembly AS-1729/VRC to Antenna Mount	4-43	4-78
Installing Roadside Antenna Mount Assembly.	4-44	4-82
Routing Roadside Antenna Cable	4-45	4-84
Installing Roadside Antenna Cables	4-46	4-86
Installing Curbside and Roadside Antenna Masts	4-47	4-88
Installing Circuit Breaker and 90° Cable Connector	4-48	4-92
Power Cable	4-49	4-94
Installing 26-Foot Power Cable to Circuit Breaker Box	4-50	4-94
Routing and Fastening 26-Foot Power Cable.	4-51	4-98
4 x 4-inch Outlet Box	4-52	4-100
Installing 4 x 4-inch Outlet Box and Cable Connector.	4-53	4-100
Installing Power Cable and Receptacle	4-54	4-102
Power Supply	4-55	4-104
Preparing Power Cable for Connection to Hubbell Connector Plug.	4-56	4-104
Preparing Power Cable for Connection to Power Supply	4-57	4-106
Connecting Power Cable to Power Supply	4-58	4-108
Installing PP-1104 Power Supply	4-59	4-110
Installing PP-4763 Power Supply	4-60	4-112
Connecting Power Supply Cable from DC/DC Switch to Power Supply.	4-61	4-114
Installing PP-1104 Power Supply Guard Assembly	4-62	4-116
Installing External Grounding Rod Kit	4-63	4-118

4-5. TACFIRE RACK.

Assembly instructions for the Tacfire rack are given in this section.

- Installing electronic equipment table to radio mount
- Installing key generator rack to electronic equipment table
- Installing message entry group rack to electronic equipment table
- Installing electronic line printer rack to electronic equipment table
- Installing wall support to tacfire rack

4-6. INSTALLING ELECTRONIC EQUIPMENT TABLE TO RADIO MOUNT.

This task covers:

Installation

INITIAL SETUP

Tools

1/2-inch box wrench (2 required)

Personnel Required

Two mechanics

Materials/Parts

- 5/16-24 x 2 1/4 inch long hex head screw (8 required)
- 5/16-24 nut, self-locking (8 required)
- 5/16-inch flat washer (16 required)
- Electronic equipment table
- Radio mount

Equipment Condition

Electronic equipment table and radio mount holes predrilled.

LOCATION	ITEM	ACTION REMARKS
----------	------	-------------------

NOTE

A helper will be needed to lift electronic equipment table onto radio mount.

1. Outside vehicle	Electronic equipment table (1) and radio mount (2)	Put electronic equipment table on radio mount and align holes.
--------------------	--	--

4-6. INSTALLING ELECTRONIC EQUIPMENT TABLE TO RADIO MOUNT. (CONT)

LOCATION	ITEM	ACTION REMARKS
2. Electronic equip- ment table and radio mount	Screw (3), flat washers (4) and nut (5)	Install, handtighten. There are eight screws. Step 2 is typical for all eight screws.
3.	Screw holes (6)	Do step 2 again.
4.	Screw (3) and nut (5)	Using two 1/2-inch box wrenches, tighten. There are eight screws. Step 4 is typical for all eight screws.
5.	Screws (3) and nut (5)	Do step 4 again.

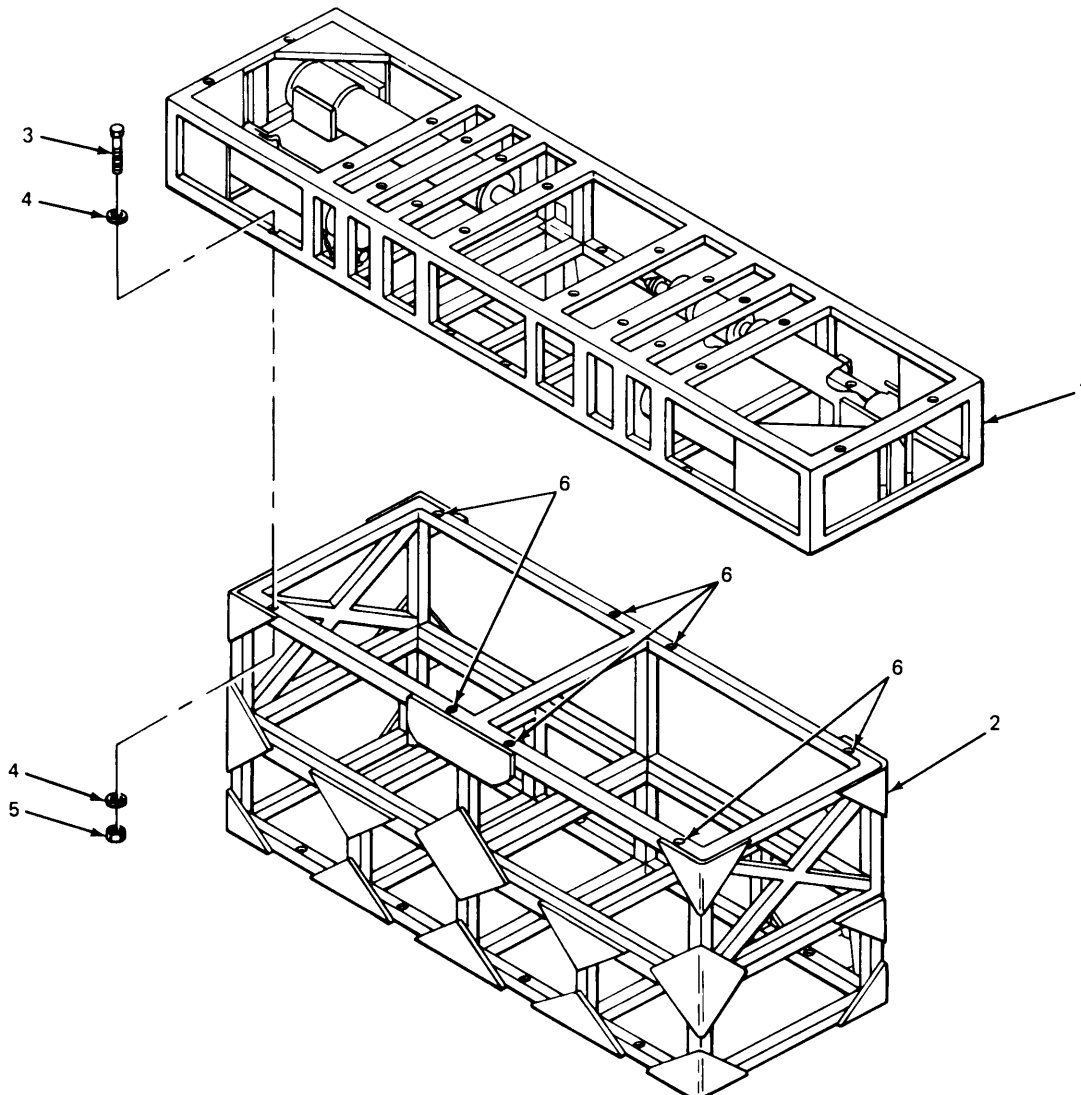

FL8KD005

4-7. INSTALLING KEY GENERATOR RACK TO ELECTRONIC EQUIPMENT TABLE.

This task covers:

Installation

INITIAL SETUP

Tools

1/2-inch box wrench (2 required)

Personnel Required

One mechanic

Materials/Parts

5/16-24 x 2 1/4 inch long hex head screw (4 required)
 5/16-inch flat washer (8 required)
 5/16-inch nut, self-locking (4 required)
 Key generator rack

Equipment Condition

Mounting holes predrilled.

	LOCATION	ITEM	ACTION REMARKS
1.	Electronic equipment table, road-side	Key generator rack (1) and electronic equipment table (2)	Put key generator rack on electronic equipment table and align holes.
2.	Key generator and electronic equipment table	Screw (3), flat washers (4) and nut (5)	Install, handtighten. There are four screws. Step 2 is typical for all four screws.
3.		Screw holes (6)	Do step 2 again.
4.		Screw (3) and nut (5)	Using two 1/2-inch box wrenches, tighten. There are four screws. Step 4 is typical for all four screws.
5.		Screws (3) and nuts (5)	Do step 4 again.

4-7. INSTALLING KEY GENERATOR RACK TO ELECTRONIC EQUIPMENT TABLE. (CONT)

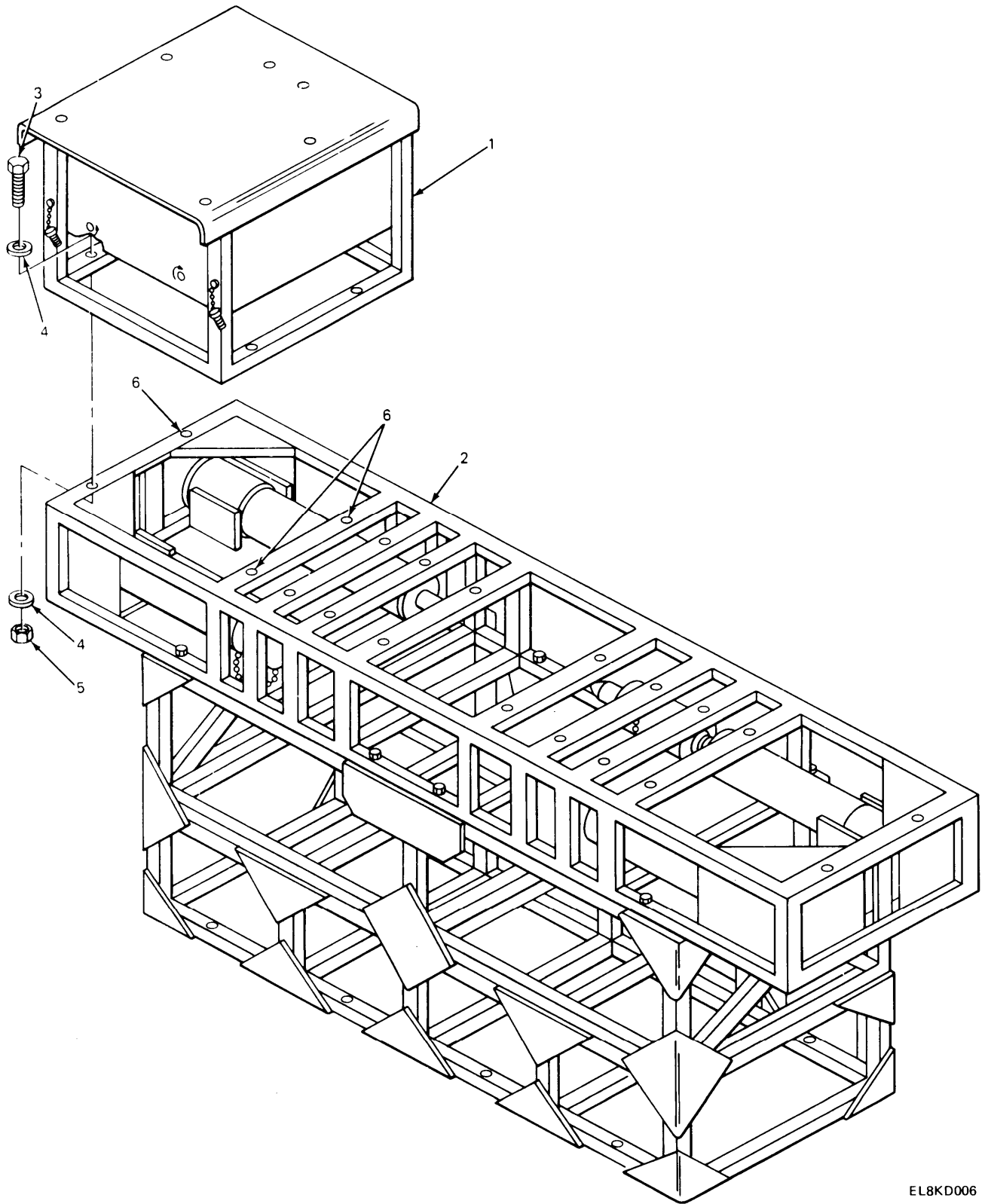

EL8KD006

4-8. INSTALLING MESSAGE ENTRY GROUP RACK TO ELECTRONIC EQUIPMENT TABLE.

This task covers:

Installation

INITIAL SETUP

Tools

1/2-inch box wrench (2 required)

Personnel Required

One mechanic

Materials/Parts

5/16-inch flat washer (8 required)
 5/16-24 x 2 1/4 inch long hex head
 screw (4 required)
 5/16-inch nut, self-locking (4 required)
 Message entry group rack

Equipment Condition

Key generator rack installed.

LOCATION	ITEM	ACTION REMARKS
1. Electronic equip- ment table, center position	Message entry group rack (1) and electronic equipment table (2)	Put message entry group rack on electronic equipment table and aline holes.
2. Key generator rack and electronic equipment table	Screw (3), flat washers (4) and nut (5)	Install, handtighten. There are four screws. Step 2 is typical for all four screws.
3.	Screw holes (6)	Do step 2 again.
4.	Screw (3) and nut (5)	Using two 1/2-inch box wrenches, tighten There are four screws. Step 4 is typical for all four screws.
5.	Screws (3) and nuts (5)	Do step 4 again.

4-8. INSTALLING MESSAGE ENTRY GROUP RACK TO ELECTRONIC EQUIPMENT TABLE. (CONT)

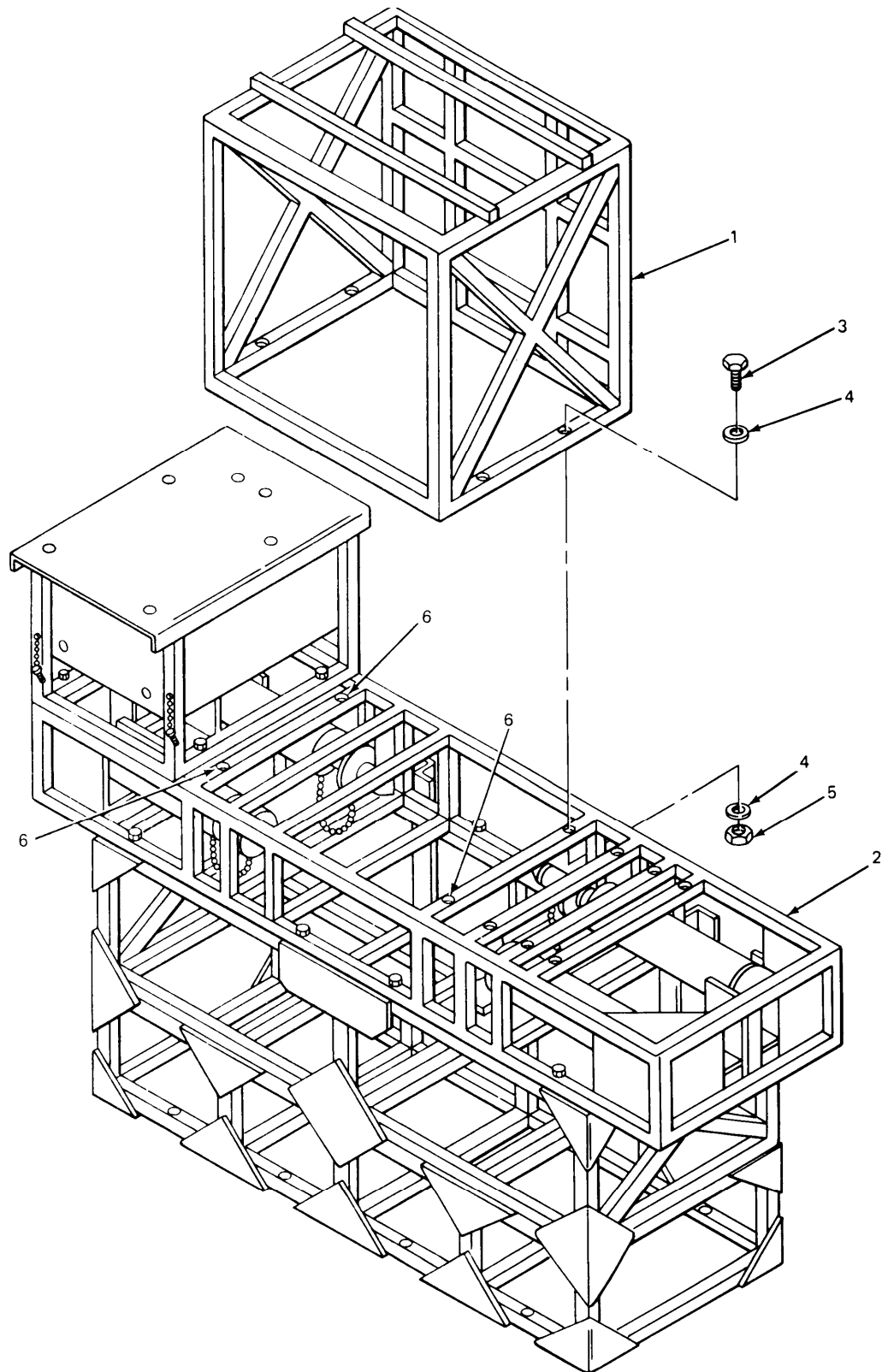

EL8KD007

4-9. INSTALLING ELECTRONIC LINE PRINTER RACK TO ELECTRONIC EQUIPMENT TABLE.

This task covers:

Installation

INITIAL SETUP

Tools

1/2-inch box wrench (2 required)

Personnel Required

One mechanic

Materials/Parts

5/16-inch nut, self-locking
(4 required)
5/16-24 x 2 1/4 inch long hex head
screw (4 required)
5/16-inch flat washers (8 required)
Electronic line printer rack

Equipment Condition

Message entry group rack installed.

	LOCATION	ITEM	ACTION REMARKS
1.	Electronic equip- ment table, curb- side	Electronic line printer (1) and electronic equip- ment table (2)	Put electronic line printer rack on electro- nic equipment table and aline holes.
2.	Electronic line printer rack and electronic equipment table	Screw (3), flat washers (4) and nut (5)	Install, handtighten. There are four screws. Step 2 is typical for all four screws.
3.		Screw holes (6)	Do step 2 again.
4.		Screw (3) and nut (5)	Using two 1/2-inch box wrenches, tighten. There are four screws. Step 4 is typical for all four screws.
5.		Screws (3) and nuts (5)	Do step 4 again.

4-9. INSTALLING ELECTRONIC LINE PRINTER RACK TO ELECTRONIC EQUIPMENT TABLE. (CONT)

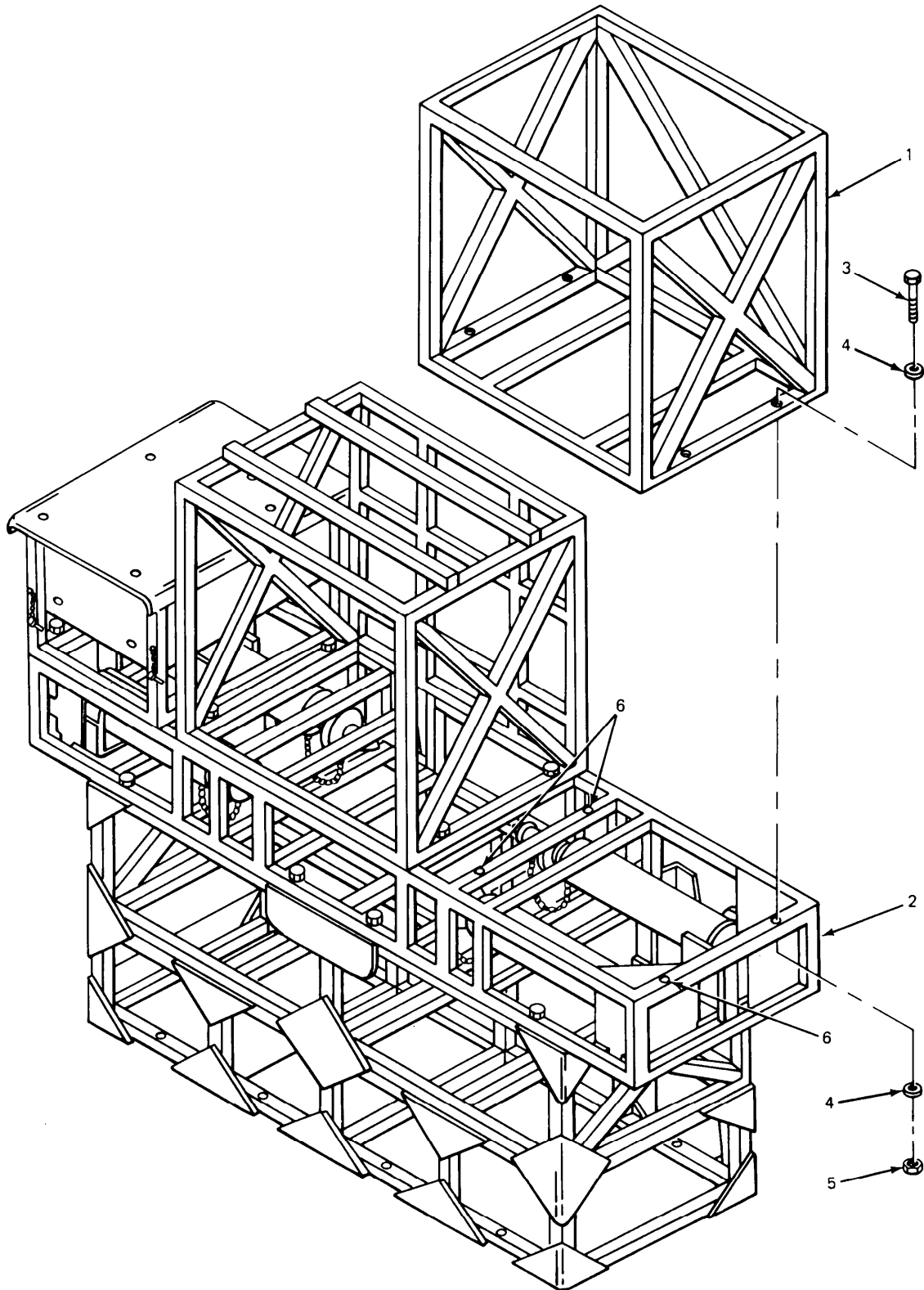

EL8KD008

4-10. INSTALLING WALL SUPPORT TO TACFIRE RACK.

This task covers:

Installation

INITIAL SETUP

Tools

1/2-inch box wrench

Personnel Required

One mechanic

Materials/Parts

5/16-18 x 1 inch long hex head screw (6 required)
 5/16-inch flat washer (6 required)
 5/16-inch lockwasher (6 required)
 Wall support

Equipment Condition

Tacfire rack assembled.

	LOCATION	ITEM	ACTION REMARKS
1.	Across the rear of electronic equipment racks	Wall support (1) and electronic equipment racks (2)	Put wall support across rear of electronic equipment racks and aline holes.
2.	Electronic equipment racks and wall support	Screw (3), lockwasher (4) and flat washer (8)	Install, handtighten. There are six screws. Step 2 is typical for all six screws.
3.		Screw holes (6)	Do step 2 again.
4.		Screw (3)	Using two 1/2-inch box wrenches, tighten. There are six screws. Step 4 is typical for ail six screws.
5.		Screws (3)	Do step 4 again.

4-10. INSTALLING WALL SUPPORT TO TACFIRE RACK. (CONT)

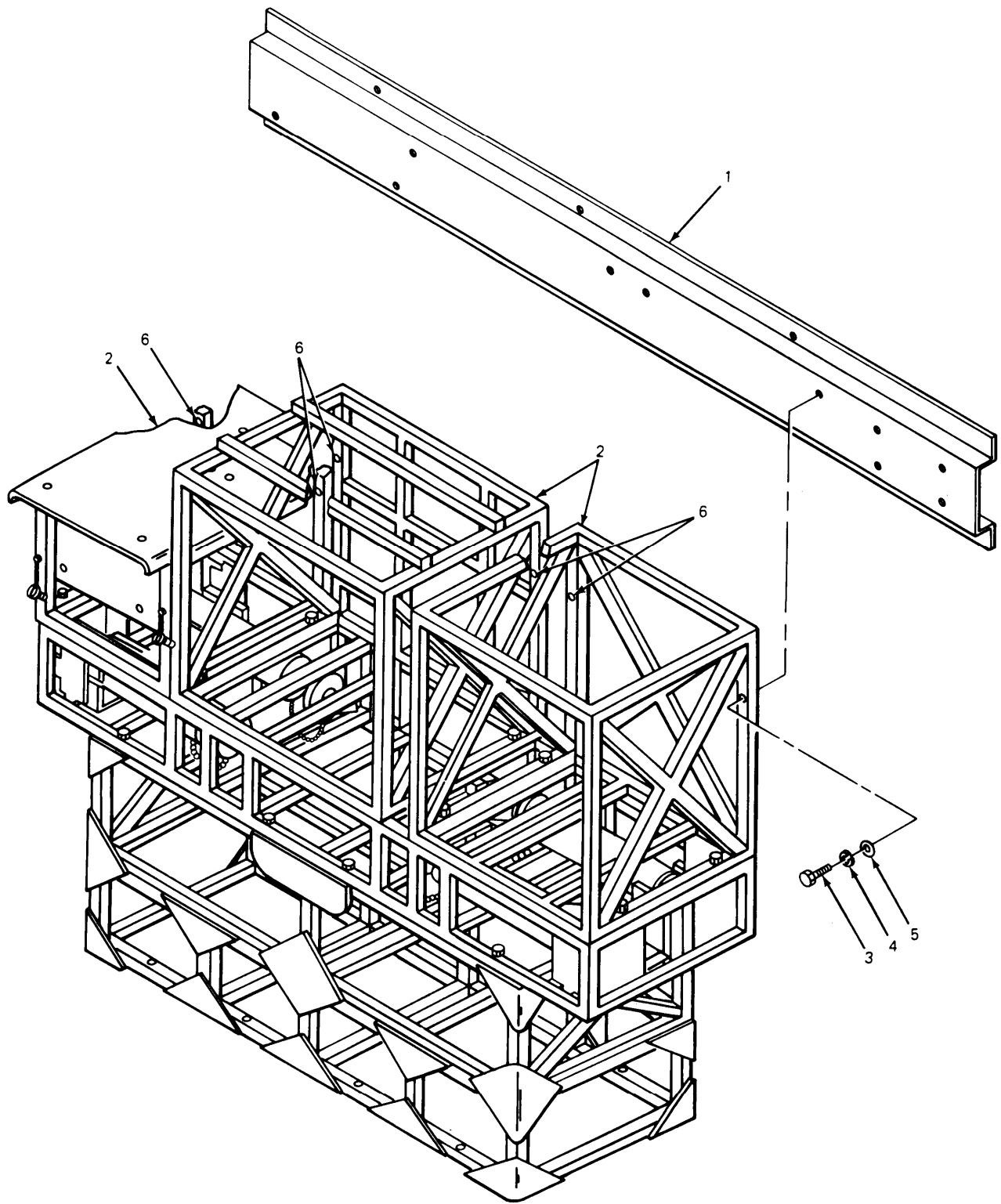

EL8KD009

4-11. INSTALLING 4-INCH GROUND STRAPS.

This task covers:

Installation

INITIAL SETUP

Tools

Personnel Required

Pliers

One mechanic

Materials/Parts

Equipment Condition

No. 10-32 brass wingnut (14 required)
 No. 10 IT lockwasher (28 required)
 Ground strap, 4-inch (7 required)

Tacfire rack assembled.

LOCATION	ITEM	ACTION REMARKS
----------	------	-------------------

NOTE

When wingnuts are tightened, hold ground strap from turning so it will not break.

- | | | |
|---|---|------------------------|
| 1. Upper studs on electronic equipment racks and electronic equipment table | Stud (1), lock-washers (2), 4-inch ground strap (3) and wingnut (4) | Using pliers, install. |
| 2. Lower studs on electronic equipment table and radio mount | Stud (5), lock-washers (6), 4-inch ground strap (3) and wingnut (7) | Using pliers, install. |

NOTE

Steps 1 and 2 are typical for all seven 4-inch ground straps.

- | | | |
|----|--------------------------|-------------------------|
| 3. | 4-inch ground straps (8) | Do steps 1 and 2 again. |
|----|--------------------------|-------------------------|

4-11. INSTALLING 4-INCH GROUND STRAPS. (CONT)

LOCATION	ITEM	ACTION REMARKS
----------	------	-------------------

NOTE

Additional ground straps are required for properly grounding the electronic equipment. Refer to TM 11-7440-251-10 and TM 11-7440-253-10-1.

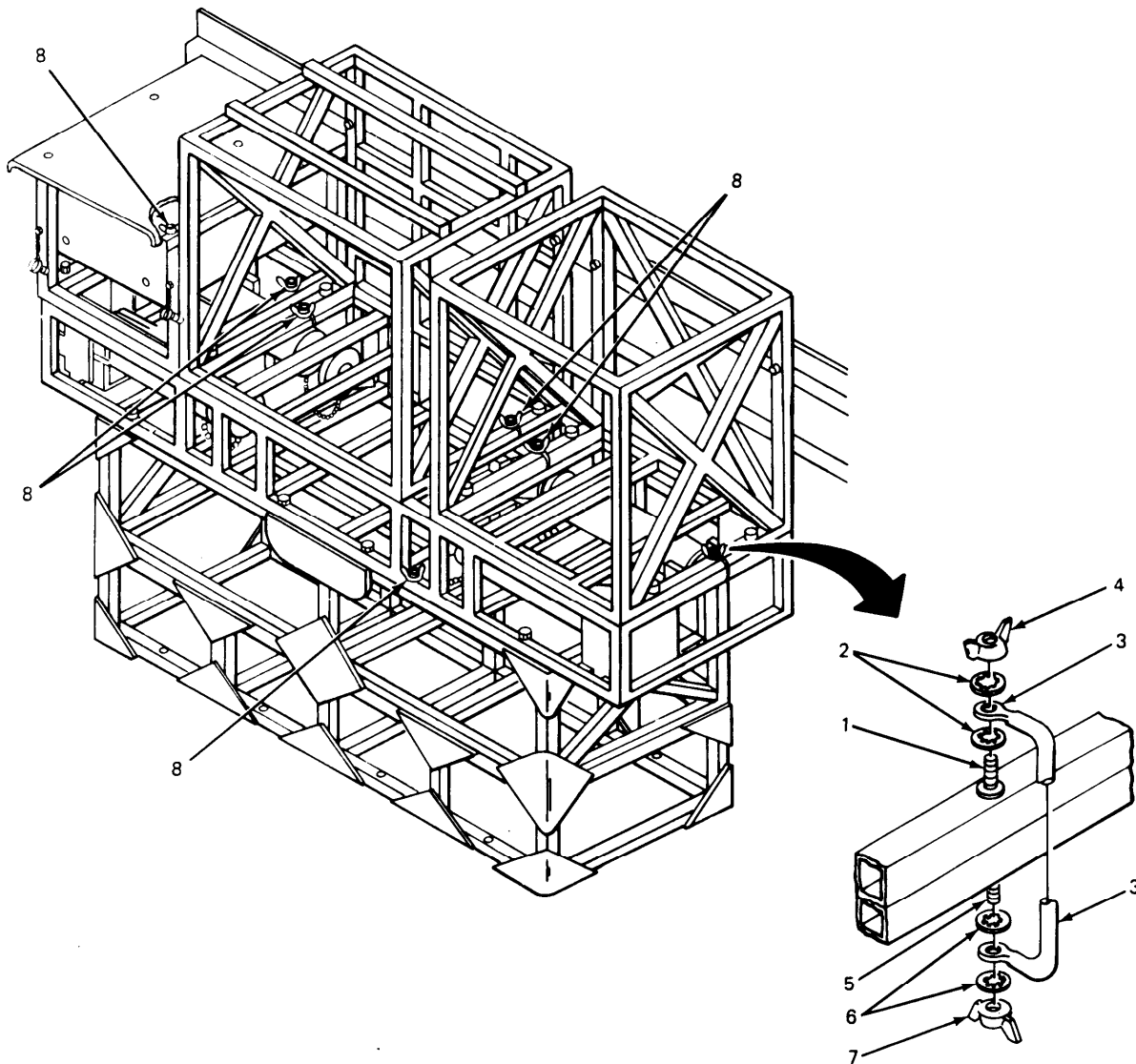

EL8KD010

4-12. INSTALLING ANGLE BRACKETS ON PP-1104 POWER SUPPLY.

This task covers:

Installation

INITIAL SETUP

Tools

Flat-tip screwdriver

Personnel Required

One mechanic

Materials/Parts

10-32 x 3/4 inch long pan head screw (10 required)
 No. 10 lockwasher (10 required)
 No. 10 flat washer (10 required)
 Angle brackets DL-SC-B866402 (2 required)
 PP-1104 power supply

Equipment Condition

Parts unpacked.

LOCATION	ITEM	ACTION REMARKS
1. At base in front of power supply	Screw (1), lock-washer (2), flat washer (3) and angle bracket (4)	Using flat-tip screwdriver, install. There are five screws. Step 1 is typical for all five screws.
2.	Screw holes (5)	Do step 1 again.
3. At base in rear of power supply	Angle bracket (6)	Do steps 1 and 2 again for rear angle bracket.

4-12. INSTALLING ANGLE BRACKETS ON PP-1104 POWER SUPPLY. (CONT)

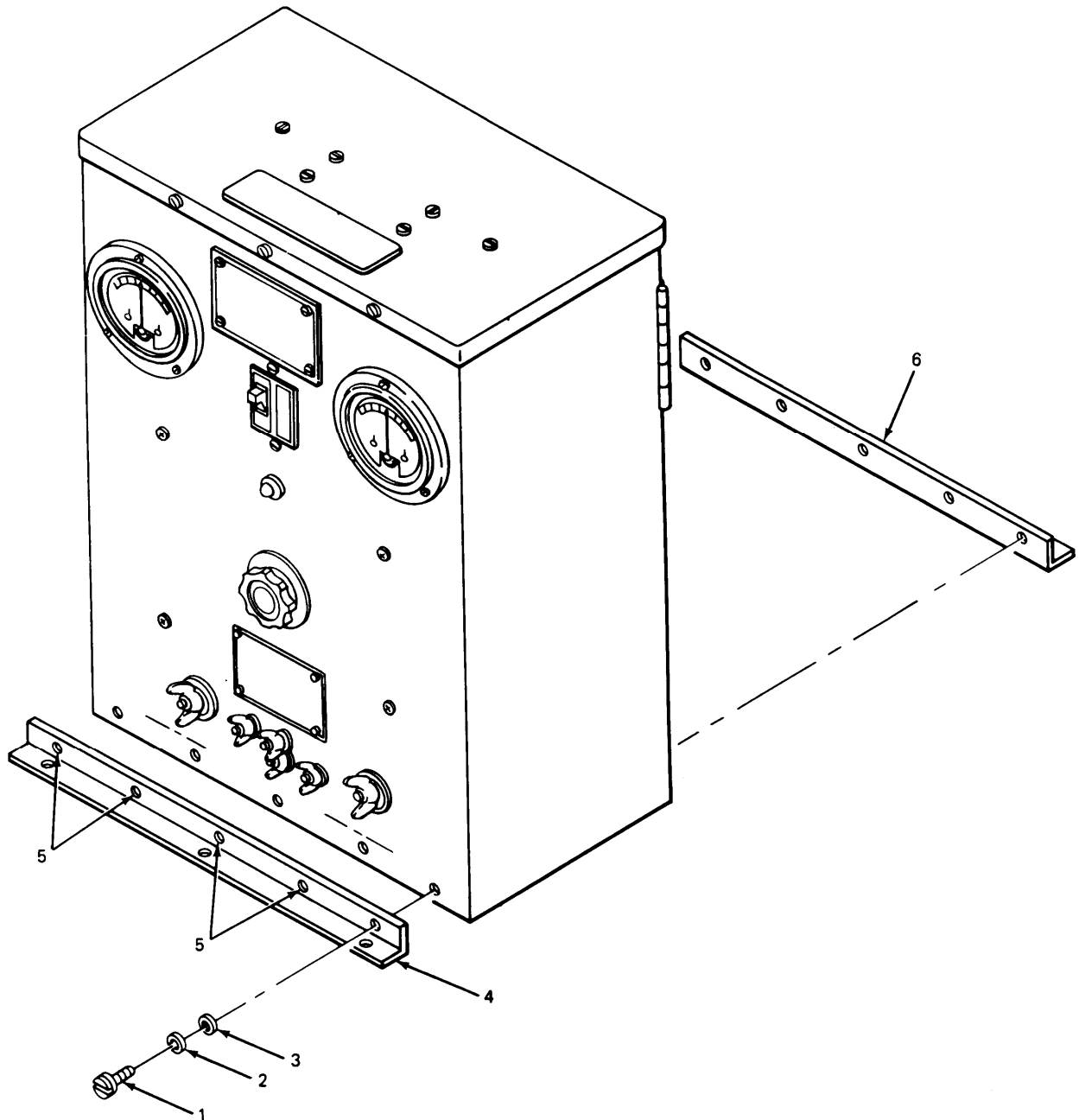

4-13. INSTALLING ANGLE BRACKETS ON PP-4763 POWER SUPPLY.

This task covers:

Installation

INITIAL SETUP

Tools

7/16-inch box wrench

Personnel Required

One mechanic

Materials/parts

PP-4763 power supply
Angle brackets, (2 required)

Equipment Condition

Parts unpacked.

LOCATION	ITEM	ACTION REMARKS
----------	------	-------------------

NOTE

Do not remove wooden runners from power supply.
Use existing hardware to install angle brackets.

1. Right side of power supply	Screw (1) and lockwasher (2)	Using 7/16-inch box wrench, remove. There are three screws. Step 1 is typical for all three screws.
2.	Screws (3)	Do step 1 again.
3.	Angle bracket (4)	Aline holes.
4.	Screw (1) and lockwasher (2)	Using 7/16-inch box wrench, install. There are three screws. Step 4 is typical for all four screws.
5.	Screw holes (5)	Do step 4 again.
6. Left side of power supply	Angle bracket (6)	Do steps 1 thru 5 again.

4-13. INSTALLING ANGLE BRACKETS ON PP-4763 POWER SUPPLY. (CONT)

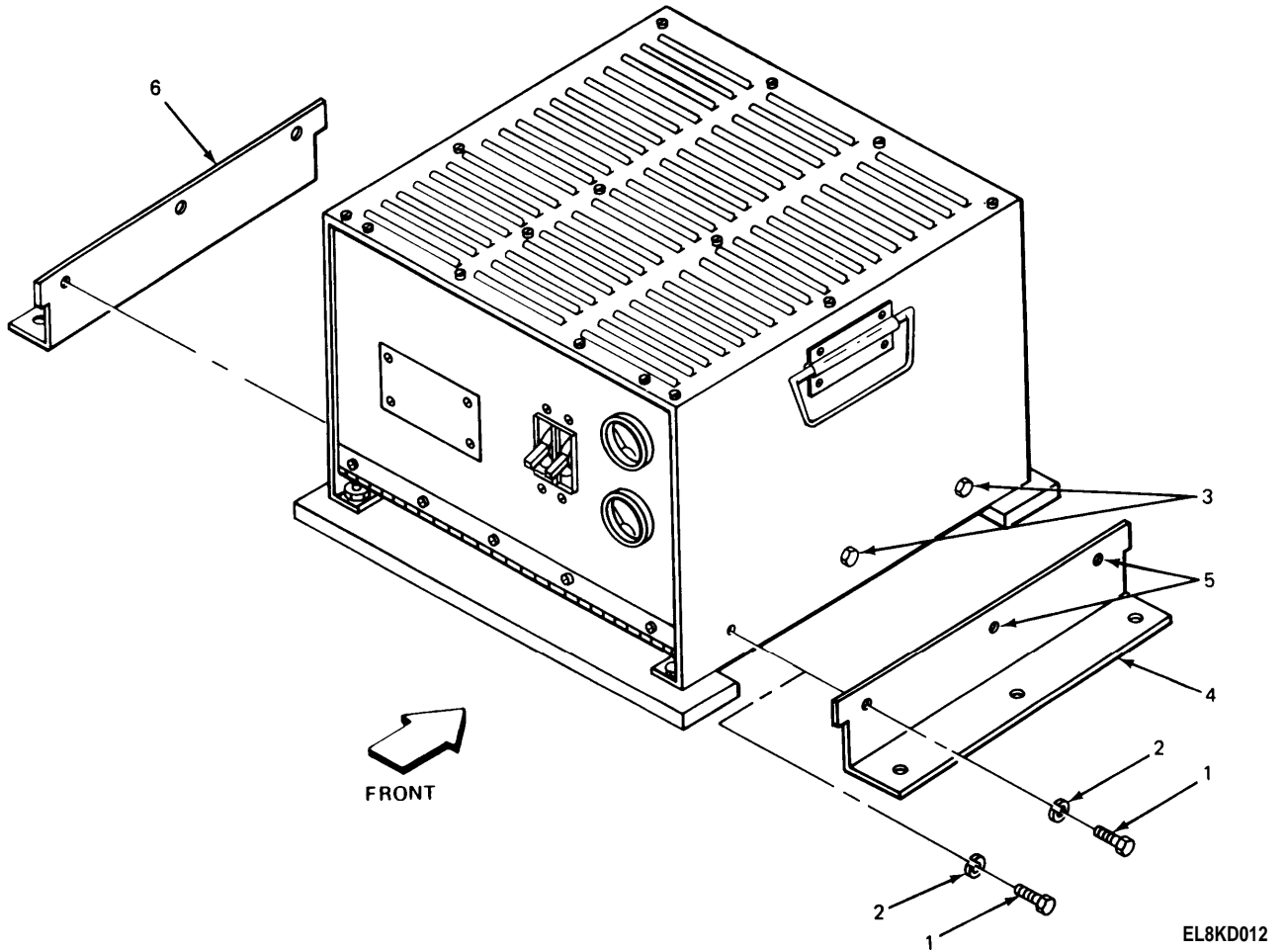

4-14. PREPARATION FOR DRILLING.

Preparation instructions for drilling are given in this section.

- Tacfire rack mounting holes
- Power supply and guard assembly mounting holes
- Pipe nipple and 30-inch ground strap mounting holes
- 90° cable connector mounting hole
- Curbside antenna cables mounting holes
- Roadside antenna cables mounting holes

4-15. TACFIRE RACK MOUNTING HOLES.

This task covers:

Preparation for drilling

INITIAL SETUP

Tools	Personnel Required
Felt-tip pen Tape measure	Two mechanics
Materials/parts	Equipment Condition
Assembled tacfire rack	Tacfire rack assembled. All heat vents closed.

LOCATION	ITEM	ACTION REMARKS
----------	------	-------------------

NOTE

A helper will be needed to lift tacfire rack into position. For better visibility and location of marked areas, clean area being marked and use a felt-tip pen or marker. The radio mount mounting holes and wall support mounting holes will be used as guides for the areas being marked. Set tacfire rack against forward wall 12 inches from roadside wall measuring from radio mount.

1. Radio mount	Mark (1)	Using felt-tip pen, mark. There are eight mounting holes. Step 1 is typical for all eight mounting holes.
2.	Mounting holes (2)	Do step 1 again.

4-15. TACFIRE RACK MOUNTING HOLES. (CONT)

LOCATION	ITEM	ACTION REMARKS
3. Wall support	Mark (3)	Using felt-tip pen, mark. There are six mounting holes. Step 3 is typical for all six mounting holes.
4.	Mounting holes (4)	Do step 3 again.
5. Forward wall	Tacfire rack (5)	Remove.

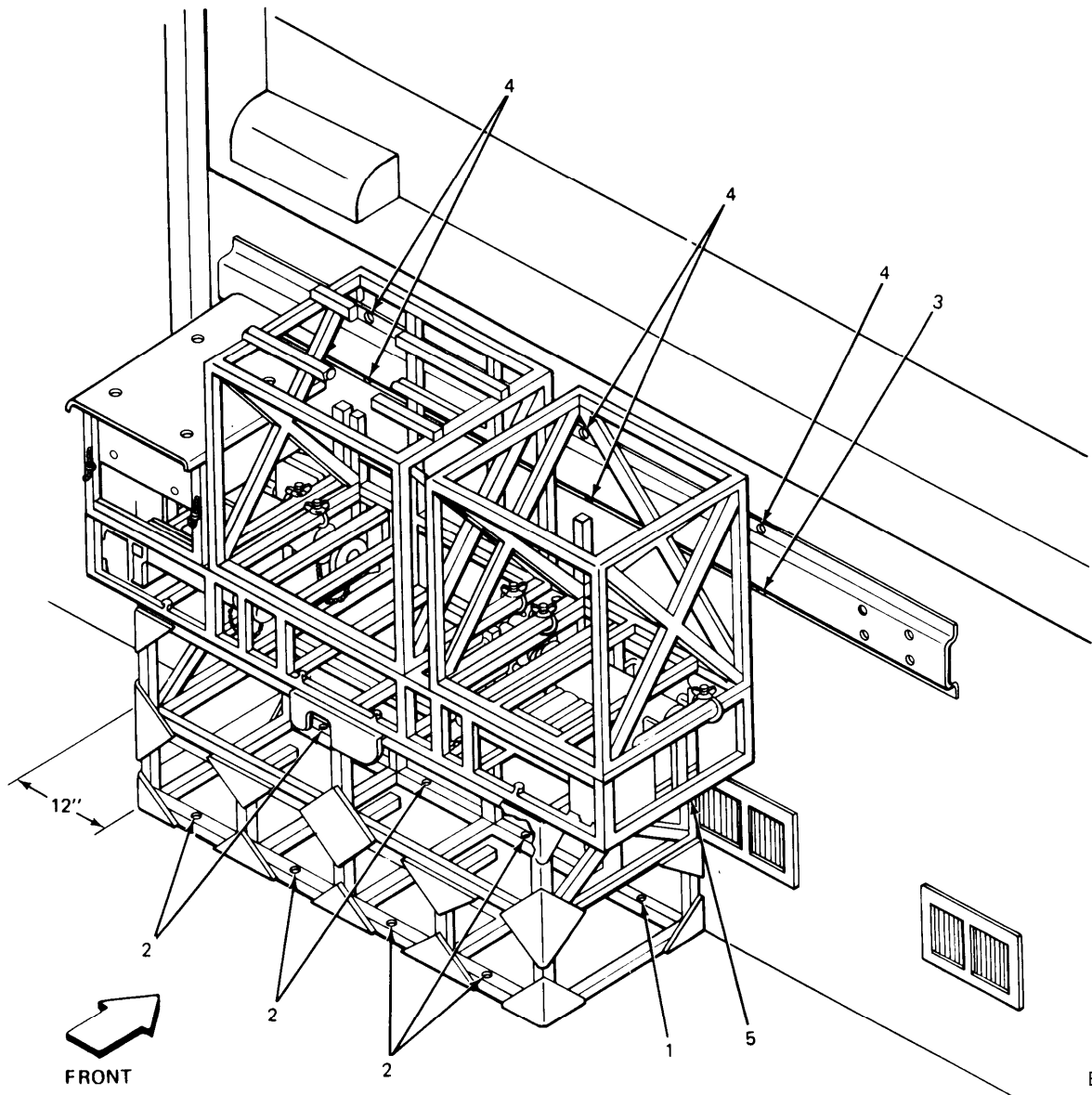

EL8KD013

4-16. PP-1104 POWER SUPPLY AND GUARD ASSEMBLY MOUNTING HOLES.

This task covers:

Preparation for drilling

INITIAL SETUP

Tools

Felt-tip pen
Tape measure

Materials/parts

PP-1104 power supply

Personnel Required

One mechanic

Equipment Condition

Angle brackets installed on power supply.

LOCATION	ITEM	ACTION REMARKS
----------	------	-------------------

NOTE

Set power supply 2 3/4 inches from curbside edge of floor plate and 7 3/4 inches from forward wall. The angle bracket mounting holes and guard assembly mounting holes will be used as guides for marking.

1. Curbside, near forward wall	Mark (1)	Using felt-tip pen, mark. There are two angle brackets. Each angle bracket has three mounting holes. Step 1 is typical for all six mounting holes.
2.	Marks (2)	Do step 1 again.

NOTE

Set guard assembly 3 inches in front of power supply and 6 inches from curbside wall.

3. In front of power supply	Mark (3)	Using felt-tip pen, mark.
4.	Mark (4)	Using felt-tip pen, mark.
5. Curbside, near forward wall	Guard assembly (5) and power supply (6)	Remove.

4.16. PP-1104 POWER SUPPLY AND GUARD ASSEMBLY MOUNTING HOLES. (CONT)

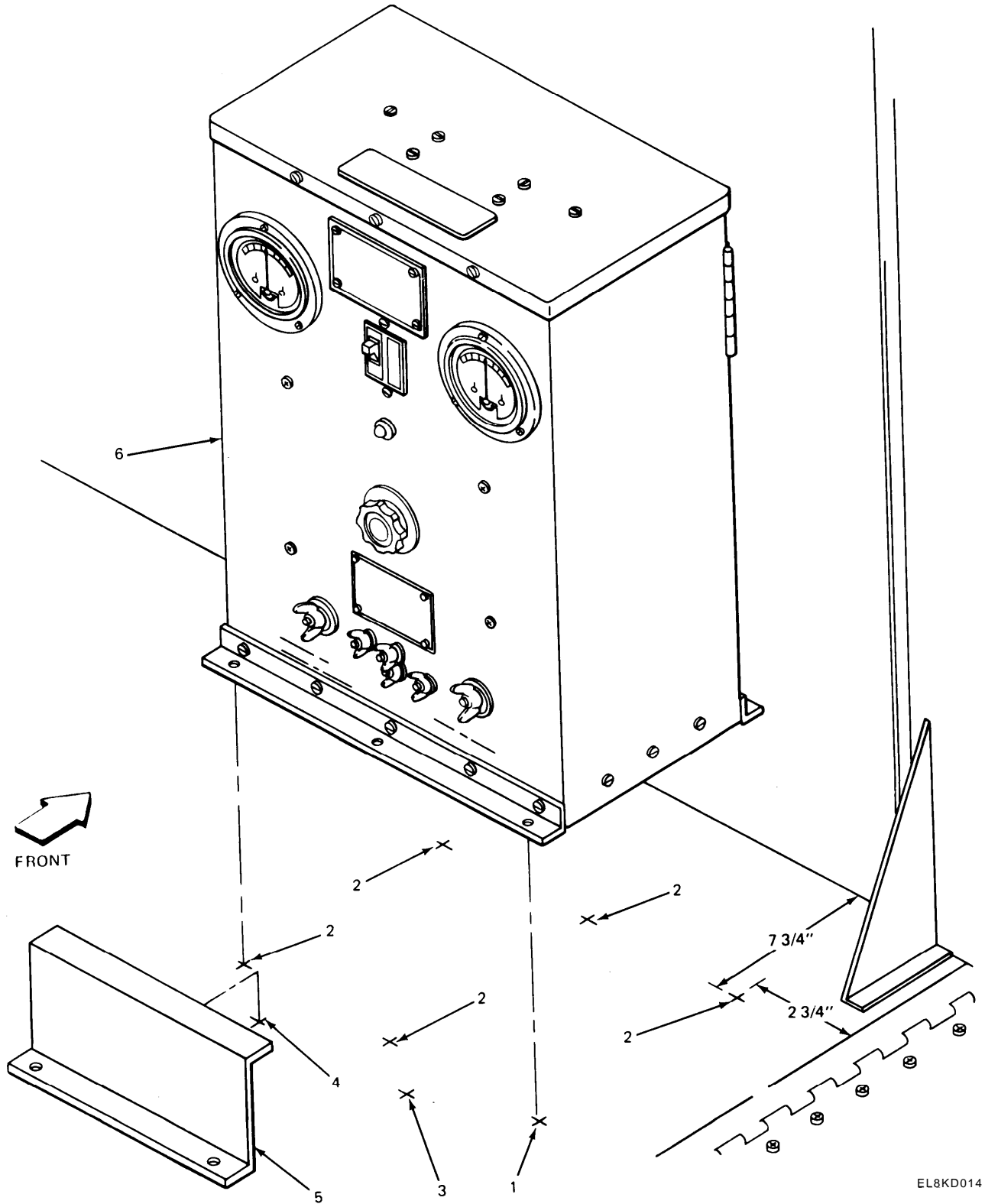

EL8KD014

4-17. PP-4763 POWER SUPPLY MOUNTING HOLES.

This task covers:

Preparation for drilling

INITIAL SETUP

Tools

Felt-tip pen
Tape measure

Materials/parts

Power supply

Personnel Required

One mechanic

Equipment Condition

Angle brackets installed on power supply.

LOCATION	ITEM	ACTION REMARKS
----------	------	-------------------

NOTE

Set power supply 5 3/4 inches from curbside edge of floor plate and 7-3/4 inches from forward wall. The angle bracket mounting holes will be used as guides for marking.

1. Curbside of power supply	Mark (1)	Using felt-tip pen, mark. There are two angle brackets. Each angle bracket has three mounting holes. Step 1 is typical for all six mounting holes.
2. Roadside of Power supply	Marks (2)	Do step 1 again.

4-17. PP-4763 POWER SUPPLY MOUNTING HOLES. (CONT)

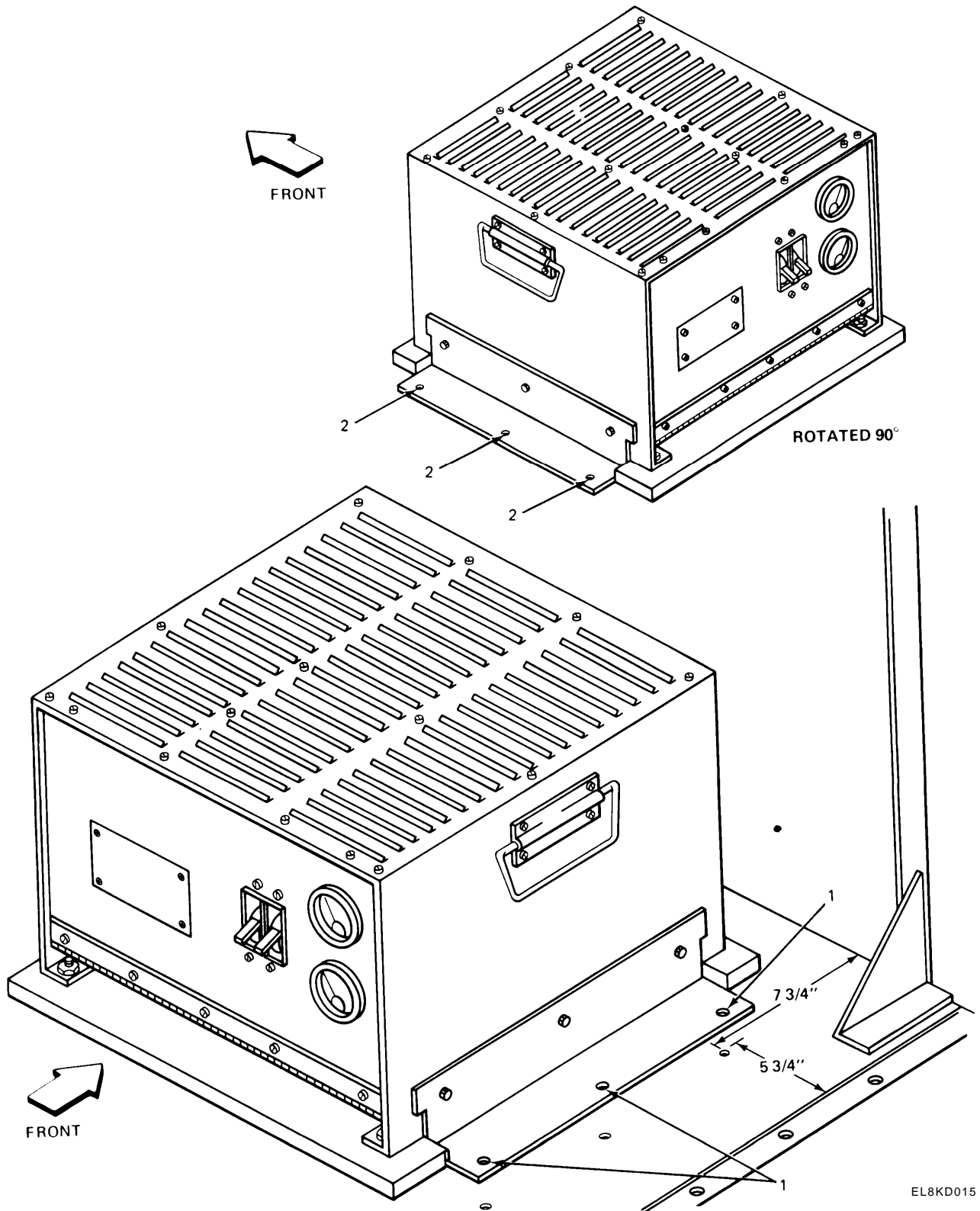

EL8KD015

4-18. PIPE NIPPLE AND 30-INCH GROUND STRAP MOUNTING HOLE

This task covers:

Preparation for drilling

INITIAL SETUP

Tools

Felt-tip pen
Tape measure

Materials/parts

None

Personnel Required

One mechanic

Equipment Condition

Area clean.

LOCATION	ITEM	ACTION REMARKS
----------	------	-------------------

NOTE

Measure a point 3 1/2 inches up from floor and 22 inches from curbside wall.

1. Forward wall

Mark (1)

Using felt-tip pen, mark.

NOTE

Measure 5 inches from floor and 1 inch from forward wall on roadside gusset plate.

2. Roadside lower gusset plate

Mark (2)

Using felt-tip pen, mark.

4-18. PIPE NIPPLE AND 30-INCH GROUND STRAP MOUNTING HOLE. (CONT)

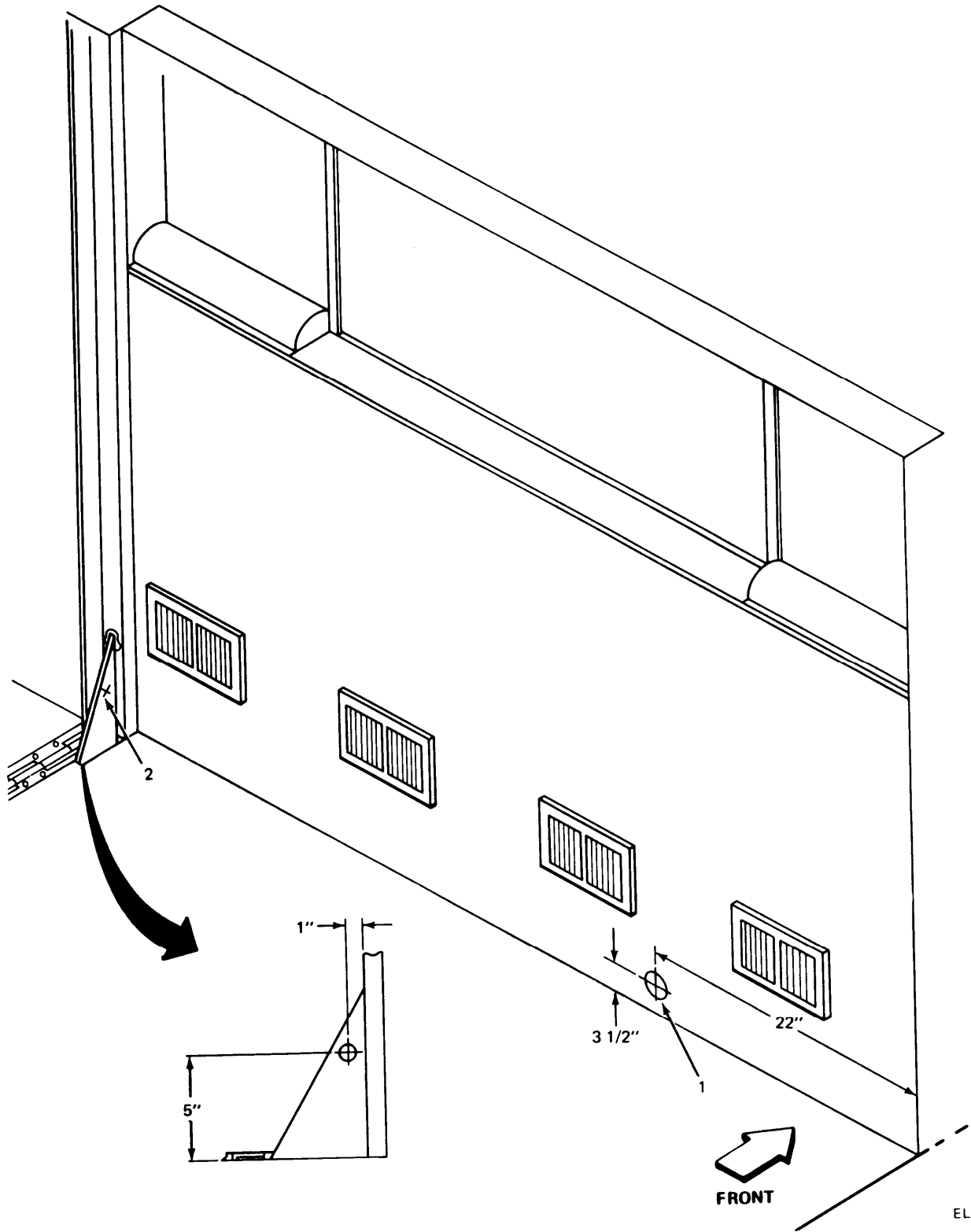

EL8KD016

4-19. CABLE CONNECTOR MOUNTING HOLE.

This task covers:

Preparation for drilling

INITIAL SETUP

Tools

Felt-tip pen
Tape measure

Materials/Parts

None

Personnel Required

One mechanic

Equipment Condition

Clean area.

LOCATION	ITEM	ACTION REMARKS
----------	------	-------------------

NOTE

Measure down 5 inches from the ceiling and 1-1/4 inches from the front edge on the circuit breaker box.

Upper roadside
of circuit
breaker box

Mark (1)

Using felt-tip pen, mark.

4-20. CURBSIDE ANTENNA CABLE MOUNTING HOLES.

This task covers:

Preparation for drilling

INITIAL SETUP

Tools

Felt-tip pen
Tape measure

Materials/parts

None

Personnel Required

One mechanic

Equipment Condition

Area clean.

LOCATION	ITEM	ACTION REMARKS
----------	------	-------------------

NOTE

Measure 3 inches, 18 inches and 30 inches from front of lower lip under the door. Center all marks.

1. Curbside, under door

Mark (1)

Using felt-tip pen, mark.

There are three marks. Step 1 is typical for all three marks.

2.

Marks (2)

Do step 1 again.

4.20. CURBSIDE ANTENNA CABLE MOUNTING HOLES. (CONT)

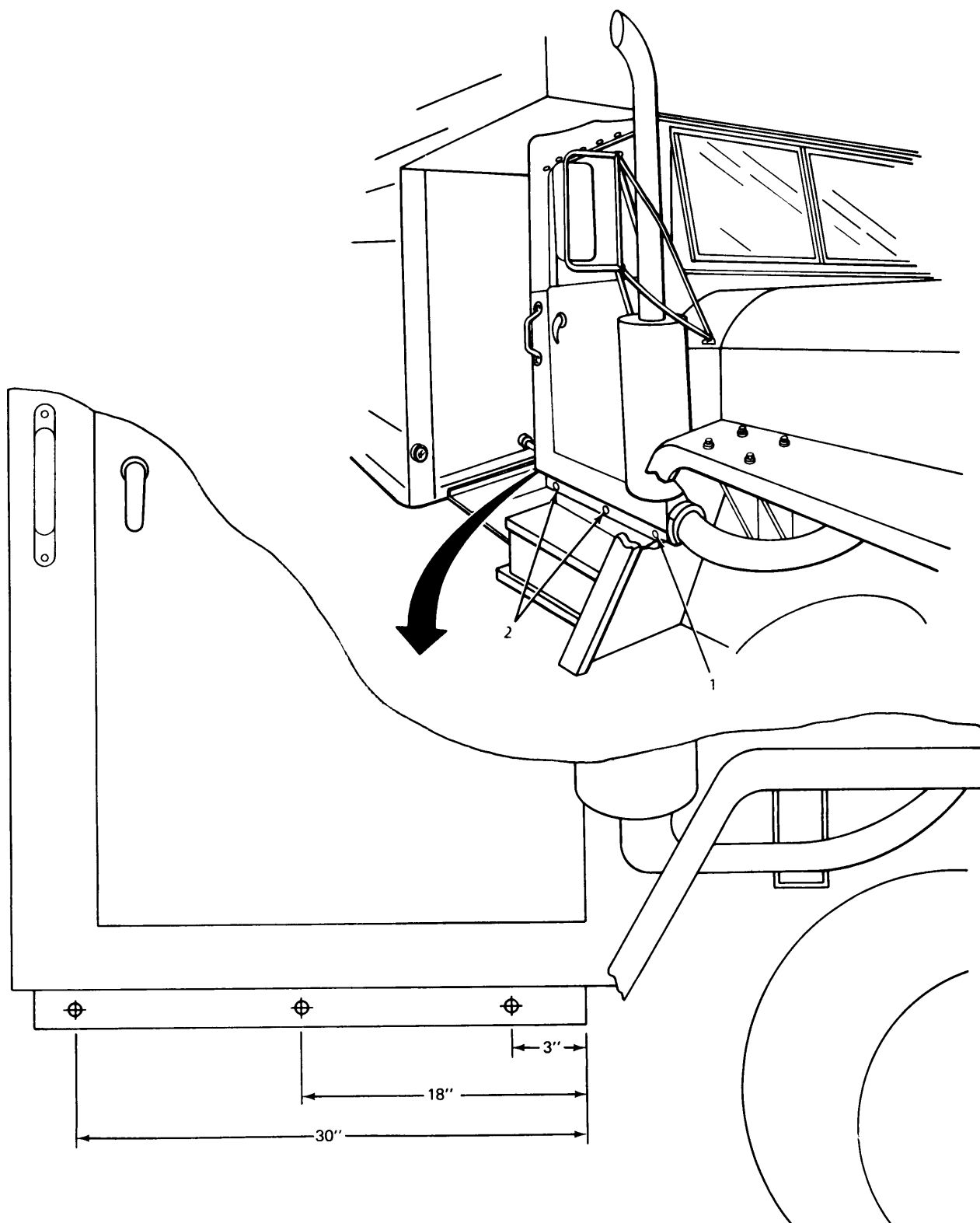

EL8KD018

4-21. ROADSIDE ANTENNA CABLE MOUNTING HOLES.

This task covers:

Preparation for drilling

INITIAL SETUP

Tools	Personnel Required
Felt-tip pen	One mechanic
Tape measure	Equipment Condition
Materials/Parts	Area clean.
None	

LOCATION	ITEM	ACTION REMARKS
----------	------	-------------------

NOTE

Measure 3 inches, 18 inches and 30 inches from front of lower lip under the door. Center all marks.

1. Roadside under door	Mark (1)	Using felt-tip pen, mark. There are three marks. Step 1 is typical for all three marks.
2.	Marks (2)	Do step 1 again.

4.21. ROADSIDE ANTENNA CABLE MOUNTING HOLES. (CONT)

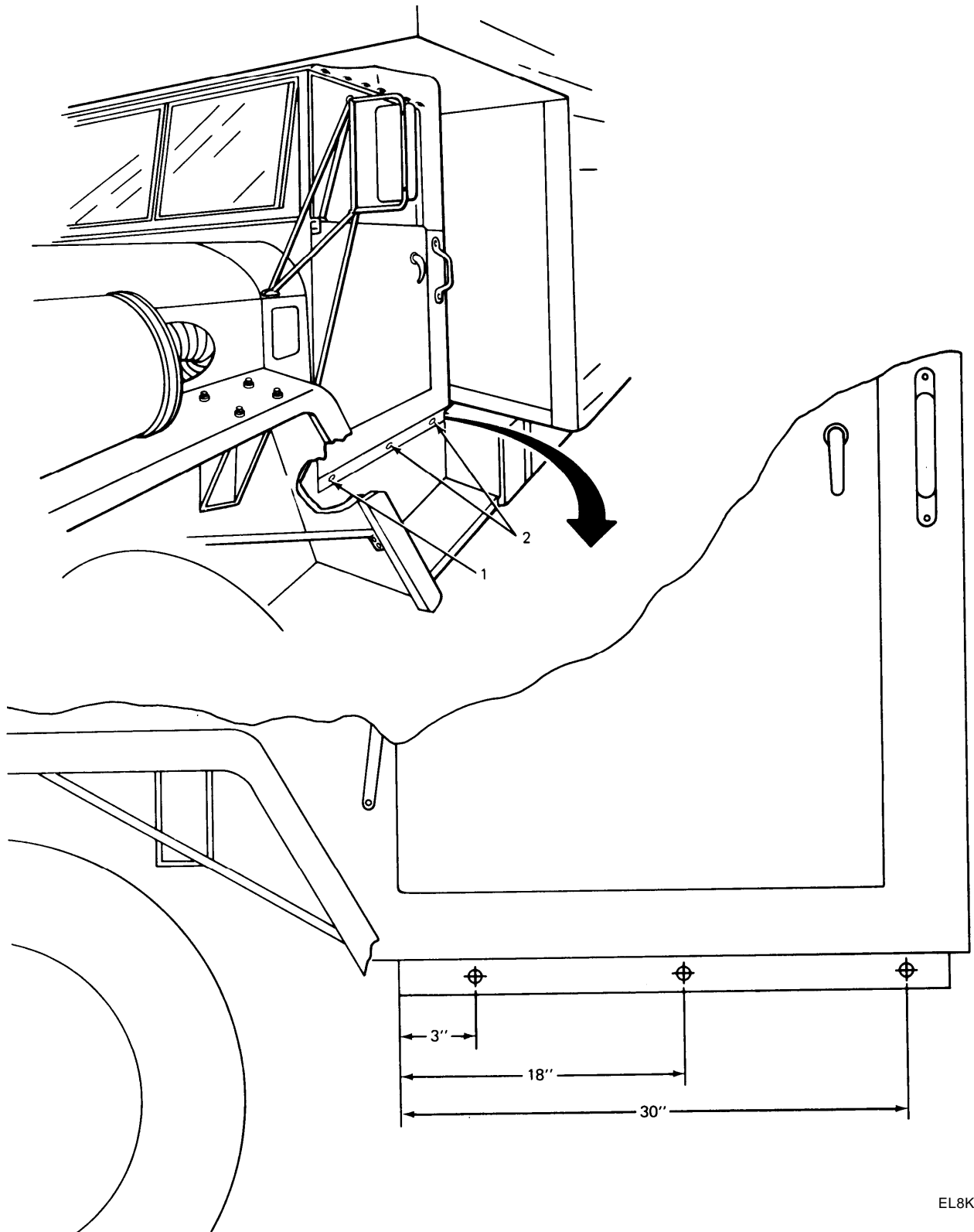

EL8KD019

4-22. CENTER PUNCHING MARKS.

This task covers:

Center punching

INITIAL SETUP

Tools

Center punch
Hammer

Materials/Parts

None

Personnel Required

One mechanic

Equipment Condition

All equipment removed from position.

LOCATION	ITEM	ACTION REMARKS
1. Center position near forward wall on floor	Radio mount mounting marks (1)	Using hammer and center punch, punch.
2. Center position on forward wall	Wall support mounting marks (2)	Using hammer and center punch, punch.
3. Curbside, near forward wall	Power supply mounting marks (3)	Using hammer and center punch, punch.
4.	Guard assembly mounting marks (4)	Using hammer and center punch, punch.
5. Lower forward wall	Pipe nipple mounting mark (5)	Using hammer and center punch, punch.
6. Roadside, lower gusset plate	30-inch ground strap mounting mark (6)	Using hammer and center punch, punch.

4-22. CENTER PUNCHING MARKS. (CONT)

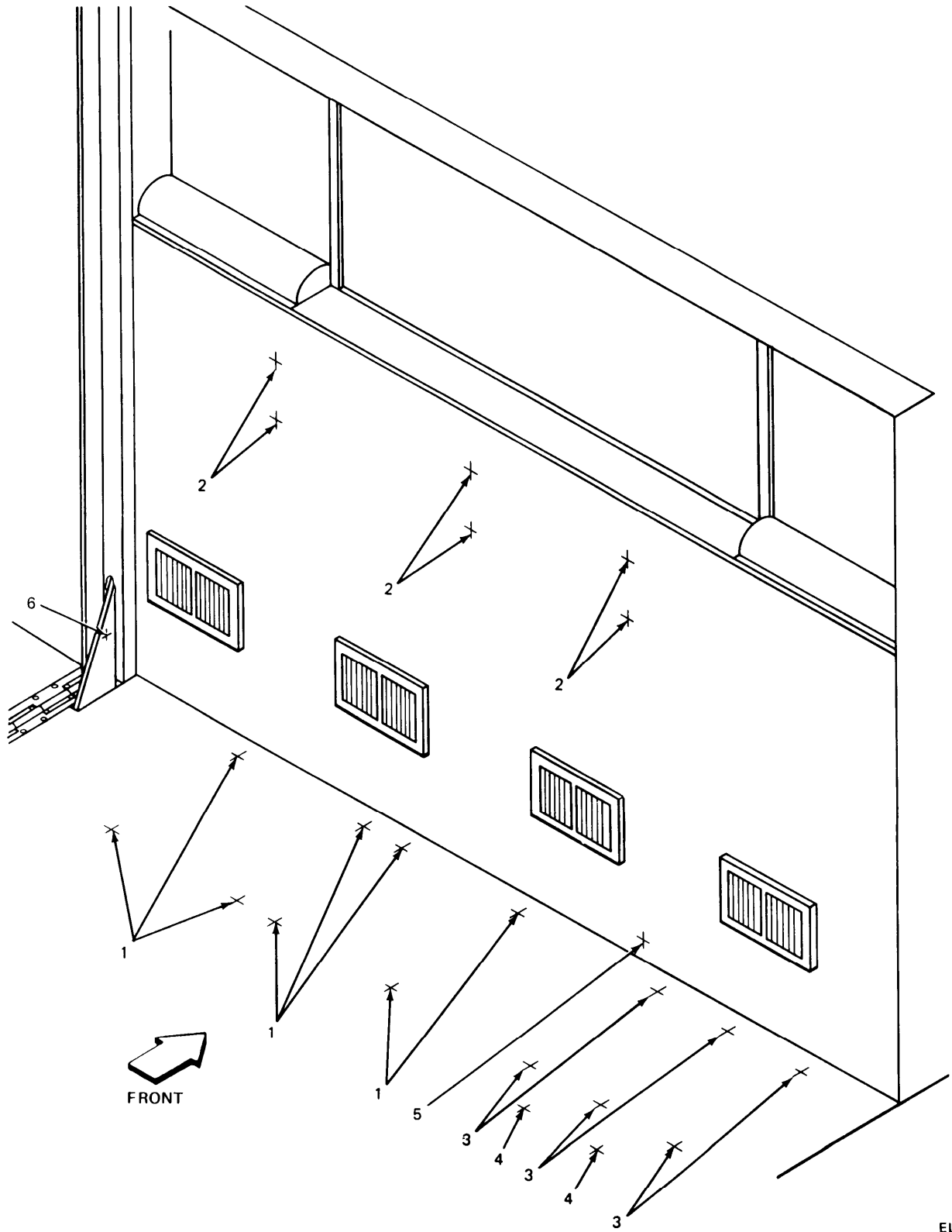

EL8KD020

4-22. CENTER PUNCHING MARKS. (CONT)

LOCATION	ITEM	ACTION REMARKS
7. Upper roadside of circuit breaker box	Cable connector mounting mark (1)	Using hammer and center punch, punch.

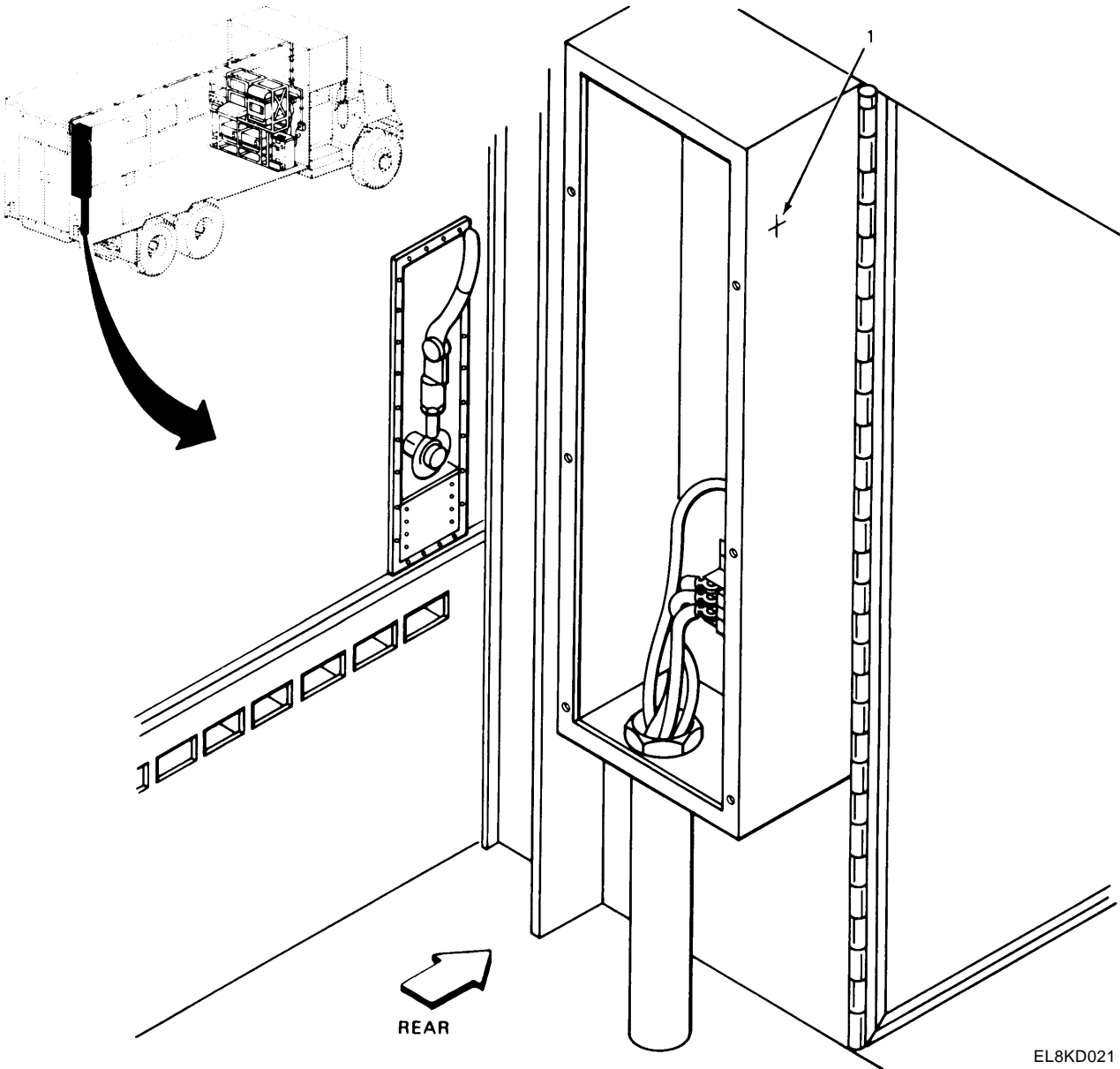

EL8KD021

4-22. CENTER PUNCHING MARKS. (CONT)

LOCATION	ITEM	ACTION REMARKS
----------	------	-------------------

8. Curbside, under door	Antenna cable mounting marks (1)	Using hammer and center punch, punch.
----------------------------	-------------------------------------	---------------------------------------

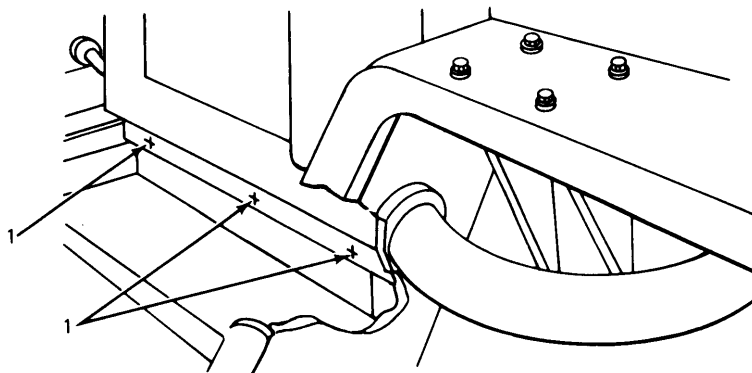

EL8KD022

9. Roadside, under door	Antenna cable mounting marks (1)	Using hammer and center punch, punch.
----------------------------	-------------------------------------	---------------------------------------

EL8KD023

4-23. DRILLING INSTRUCTIONS.

Drilling instructions are given in this section.

- Pilot drilling marks
- Drilling forward area of truck
- Drilling for flush mountings of rivnuts
- Drilling 90° cable connector hole

4-24. PILOT DRILLING MARKS.

This task covers:

Drilling

INITIAL SETUP

Tools	Personnel Required
Electric drill 1/8-inch drill bit	One mechanic
Materials/Parts	Equipment Condition
None	All holes marked and center punched.

LOCATION	ITEM	ACTION REMARKS
----------	------	-------------------

CAUTION

When holes are being drilled, make sure nothing is in path of drill bit, such as fuel lines, electrical lines, etc., and that area is well ventilated.

NOTE

Using a drilling lubricant such as oil will help keep drill bit sharp by putting a small amount on area being drilled.

4-24. PILOT DRILLING MARKS. (CONT)

LOCATION	ITEM	ACTION REMARKS
----------	------	-------------------

NOTE

If marks land on floor diamonds, chisel off entire diamond to allow flush mounting of rivnuts.

- | | | |
|---------------------------------|--|---|
| 1. Truck floor by forward wall | Radio mount mounting marks (1) | Using 1/8-inch drill bit and electric drill, drill. |
| 2. Forward wall | Wall support mounting marks (2) | Using 1/8-inch drill bit and electric drill, drill. |
| 3. Curbside, near forward wall | Power supply mounting marks (3) | Using 1/8-inch drill bit and electric drill, drill. |
| 4. | Guard assembly mounting marks (4) | Using 1/8-inch drill bit and electric drill, drill. |
| 5. Lower forward wall | Pipe nipple mounting mark (5) | Using 1/8-inch drill bit and electric drill, drill. |
| 6. Roadside, lower gusset plate | 30-inch ground strap mounting mark (6) | Using 1/8-inch drill bit and electric drill, drill. |

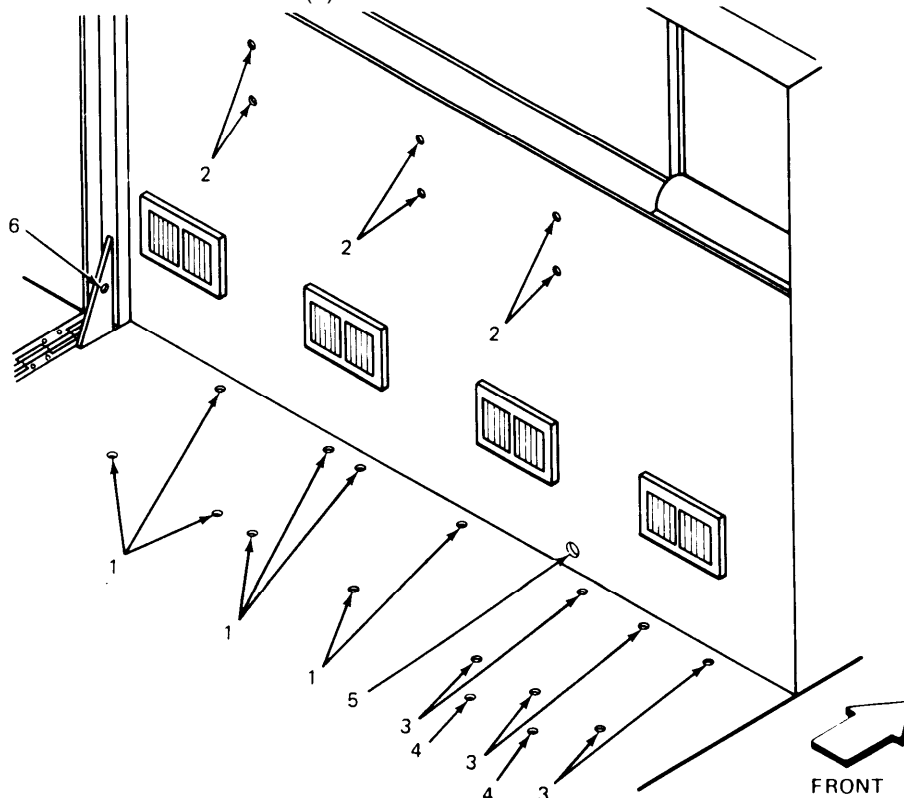

EL8KD024

4-24. PILOT DRILLING MARKS. (CONT)

LOCATION	ITEM	ACTION REMARKS
----------	------	-------------------

7. Upper roadside of circuit breaker box	Cable connector mounting mark (1)	Using 1/8-inch drill bit and electric drill, drill.
--	-----------------------------------	---

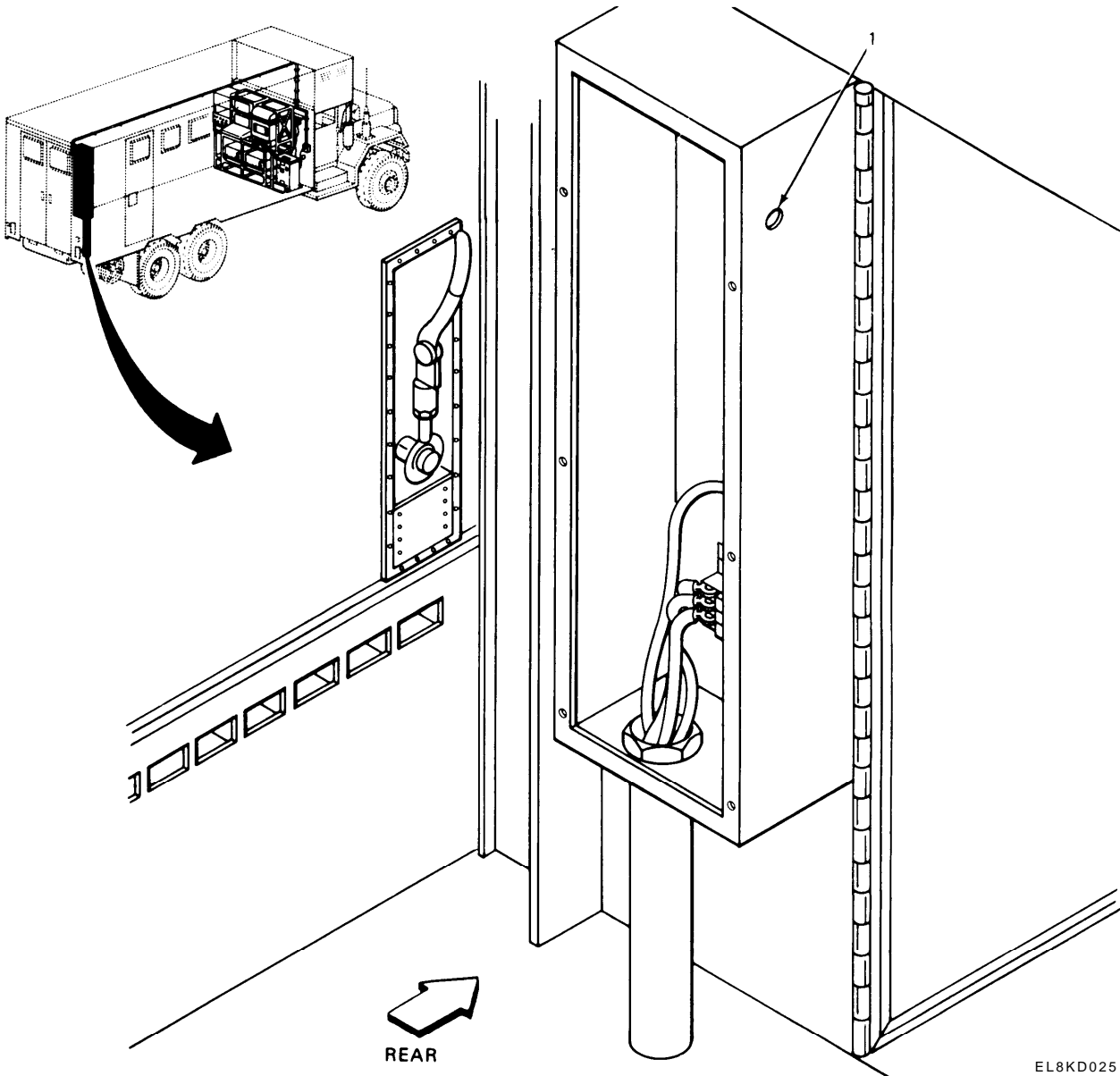

EL8KD025

4.24. PILOT DRILLING MARKS. (CONT)

LOCATION	ITEM	ACTION REMARKS
----------	------	-------------------

8. Curbside,
under door

Cable clamp
mounting
marks (1)

Using 1/8-inch drill bit and electric
drill, drill.

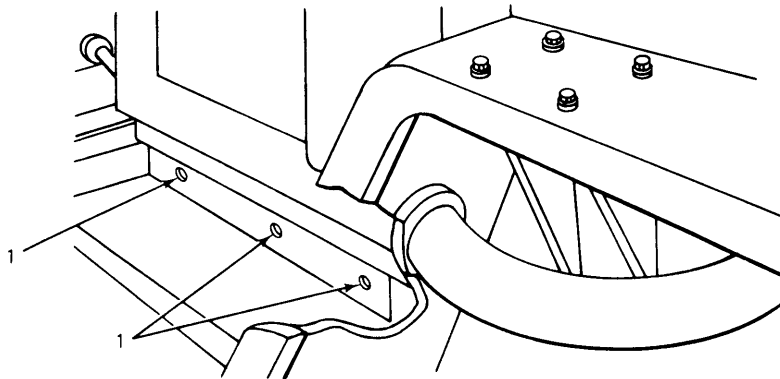

EL8KD026

9. Roadside,
under door

Cable clamp
mounting
marks (1)

Using 1/8-inch drill bit and electric
drill, drill.

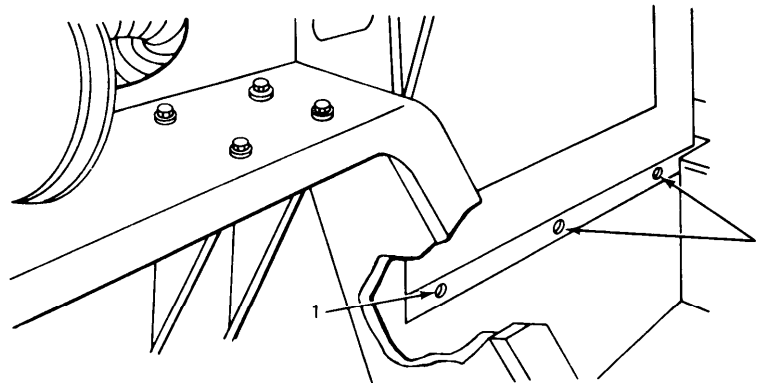

EL8KD027

4-25. DRILLING FORWARD AREA OF TRUCK.

This task covers:

Drilling

INITIAL SETUP

Tools

- Electric drill
- Z bit
- 13/32-inch drill bit
- 2-inch hole saw bit

Personnel Required

One mechanic

Equipment Condition

Pilot holes drilled.

LOCATION	ITEM	ACTION REMARKS
1. Truck floor by forward wall	Radio mounting pilot holes (1)	Using Z bit and electric drill, drill.
2. Forward wall	Wall support pilot holes (2)	Using Z bit and electric drill, drill.
3. Curbside near forward wall	Power supply pilot holes (3)	Using Z bit and electric drill, drill.
4.	Guard assembly pilot holes (4)	Using Z bit and electric drill, drill.
5. Roadside, lower gusset plate	30-inch ground strap pilot hole (5)	Using 13/32-inch drill bit and electric drill, drill.
6. Lower forward wall	Pipe nipple pilot hole (6)	Using 2-inch hole saw bit and electric drill, drill.

4-25. DRILLING FORWARD AREA OF TRUCK. (CONT)

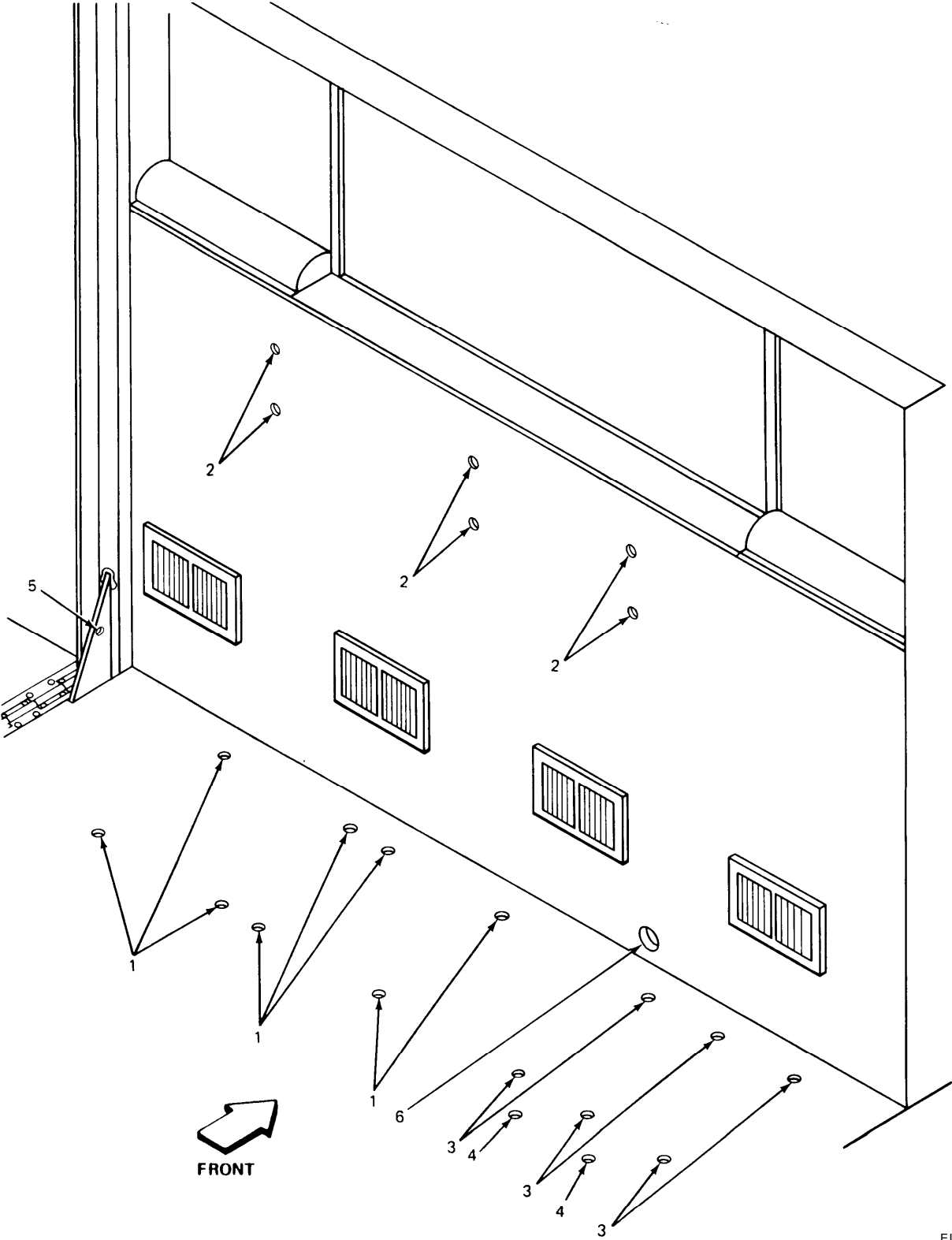

EL8KD028

4-26. DRILLING FOR FLUSH MOUNTING OF RIVNUTS.

This task covers:

Drilling

INITIAL SETUP

Tools

Electric drill
3/4-inch hole saw bit

Materials/Parts

None

Personnel Required

One mechanic

Equipment Condition

Rivnut holes drilled.

LOCATION

ITEM

ACTION
REMARKS

NOTE

Remove plywood as far as metal wall to permit rivnuts to go against metal wall.

Forward wall

Wall support
mounting holes (1)

Using 3/4-inch hole saw bit and electric drill, drill until metal is reached.

4-26. DRILLING FOR FLUSH MOUNTING OF RIVNUTS. (CONT)

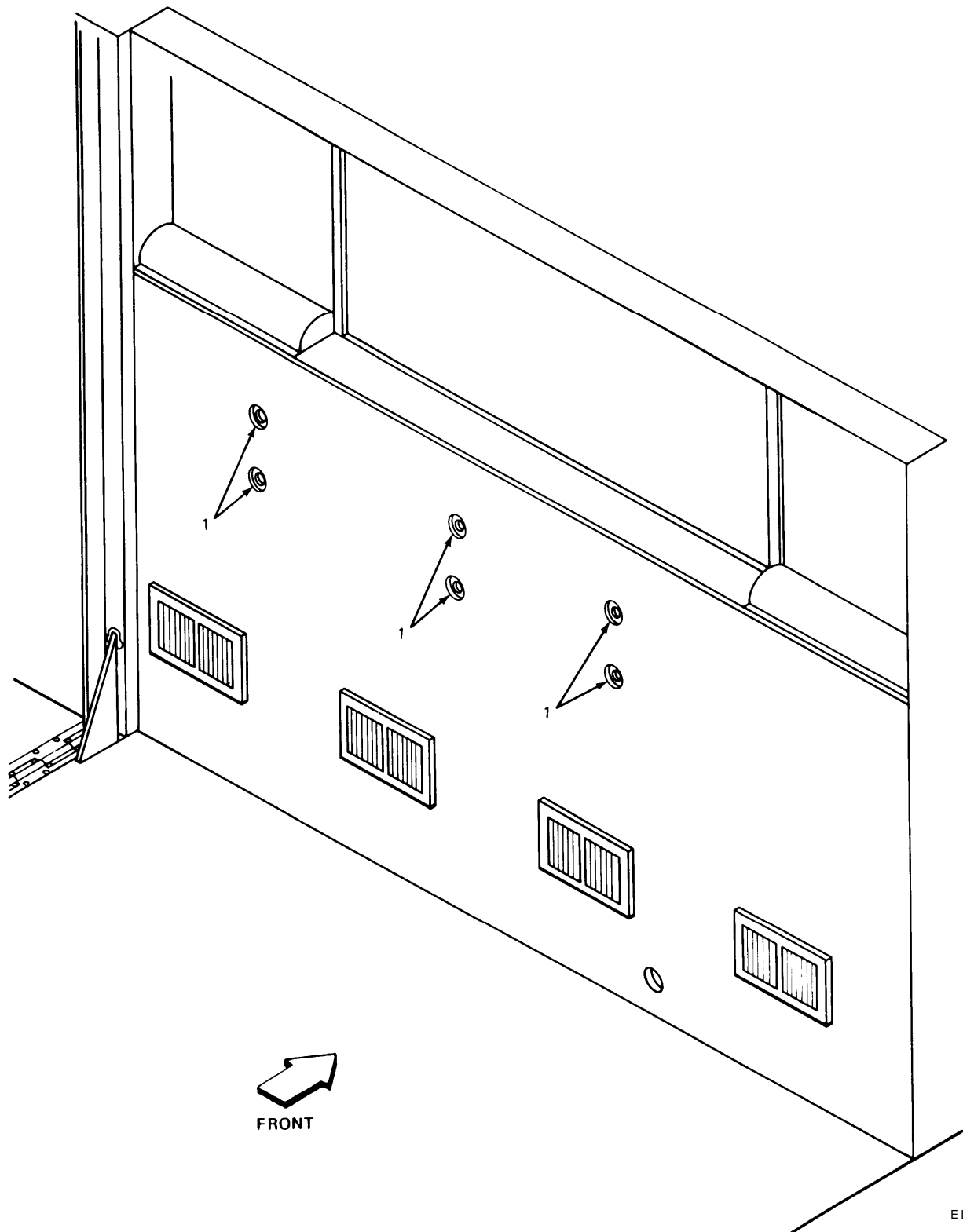

EL8KD029

4-27. DRILLING 90° CABLE CONNECTOR HOLE.

This task covers:

Drilling

INITIAL SETUP

Tools

Electric drill
7/8-inch hole saw bit

Materials/Parts

None

Personnel Required

One mechanic

Equipment Condition

Pilot hole drilled.

LOCATION	ITEM	ACTION REMARKS
----------	------	-------------------

NOTE

Make sure power is off to circuit breaker box.

Upper roadside of
circuit breaker
box

Cable connector
mounting hole (1)

Using 7/8-inch hole saw bit and electric
drill, drill.

4-27. DRILLING 90° CABLE CONNECTOR HOLE. (CONT)

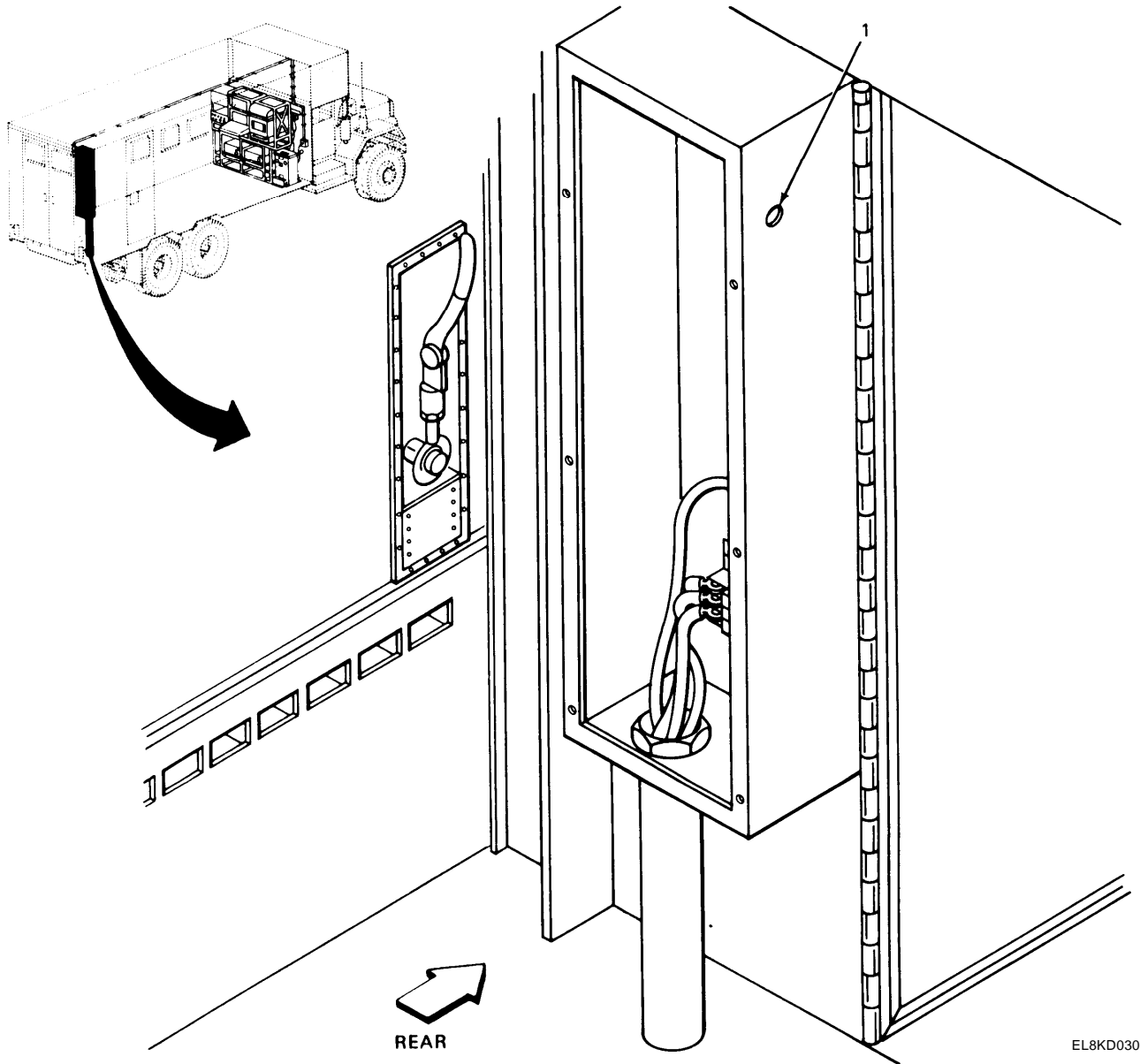

EL8KD030

4-28. INSTALLING RIVNUTS.

This task covers:

1. Use of rivnut tool
2. Installation

INITIAL SETUP

Tools

- Rivnut tool
- 3/16-inch hex wrench
- Adjustable crescent wrench

Personnel Required

One mechanic

Equipment Condition

Materials/Parts

- 5/16-18-inch rivnuts
(22 required)

Rivnut holes drilled.

LOCATION	ITEM	ACTION REMARKS
----------	------	-------------------

USE OF RIVNUT TOOL

NOTE

Chisel diamond off floor around holes so rivnut sits flush with floor.

1. Pull Up stud advance	Rivnut (1)	Install. Screw rivnut onto pull up stud advance until rivnut is tight.
2. Drilled hole	Rivnut (1)	Install. Insert rivnut tool with rivnut into drilled hole.
3. Top of rivnut tool	Hex wrench (2)	Install. Hold still.
4. Hex nut on rivnut tool	Wrench (3)	Using wrench, turn clockwise. Turn wrench 1 1/2 turns or until tight.
5. Rivnut	Rivnut tool (4)	Remove. Turn entire tool counterclockwise.

4-28. INSTALLING RIVNUTS. (CONT)

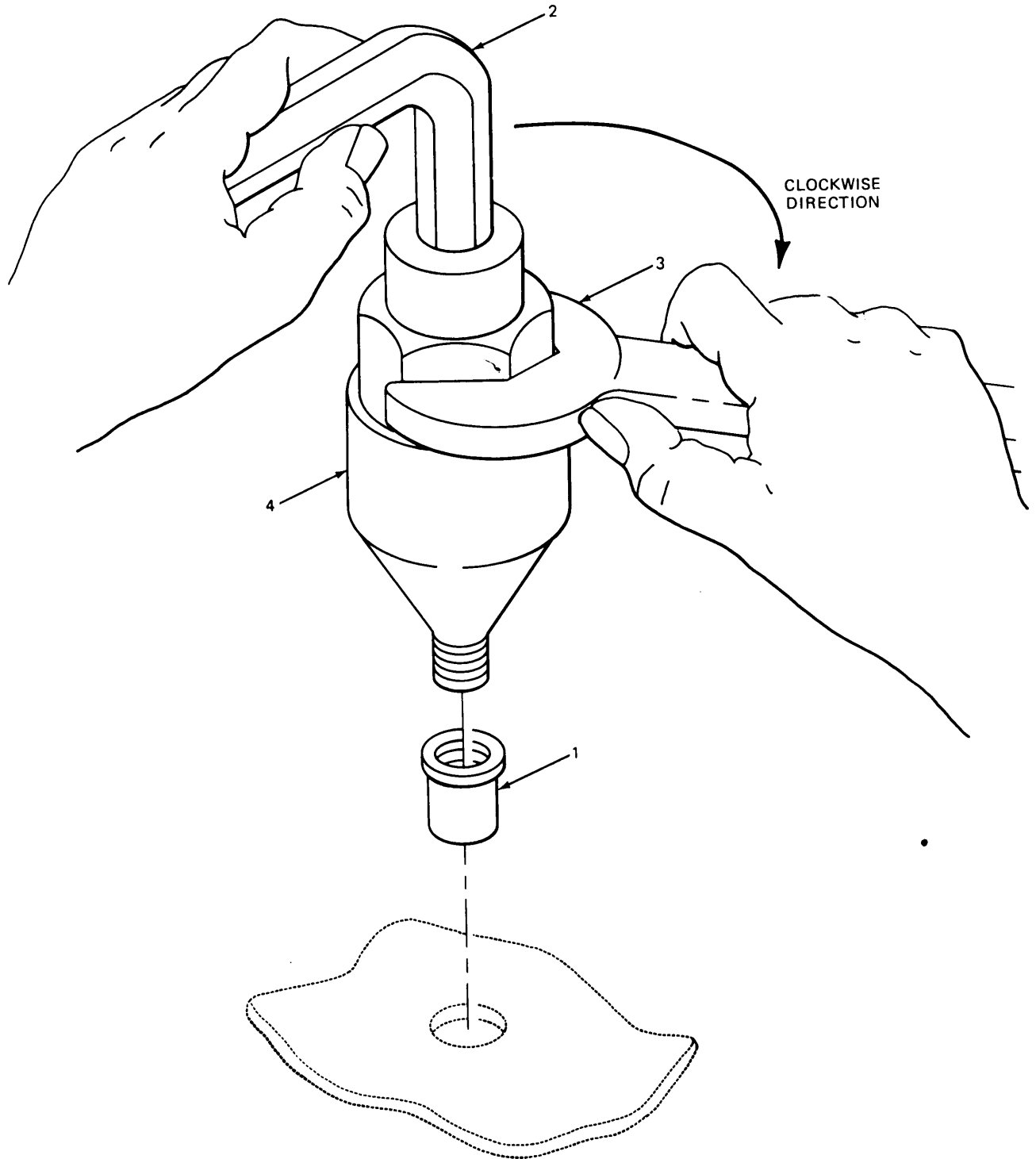

EL8KD031

4-28. INSTALLING RIVNUTS. (CONT)

LOCATION	ITEM	ACTION REMARKS
INSTALLATION		
1. Truck floor by forward wall	Radio mounting base holes (1)	Using rivnut tool and rivnuts, install.
2. Forward wall	Wall support mounting holes (2)	Using rivnut tool and rivnuts, install.
3. Curbside, near forward wall	Power supply mounting holes (3)	Using rivnut tool and rivnuts, install.
4.	Guard assembly mounting holes (4)	Using rivnut tool and rivnuts, install.

4.28. INSTALLING RIVNUTS. (CONT)

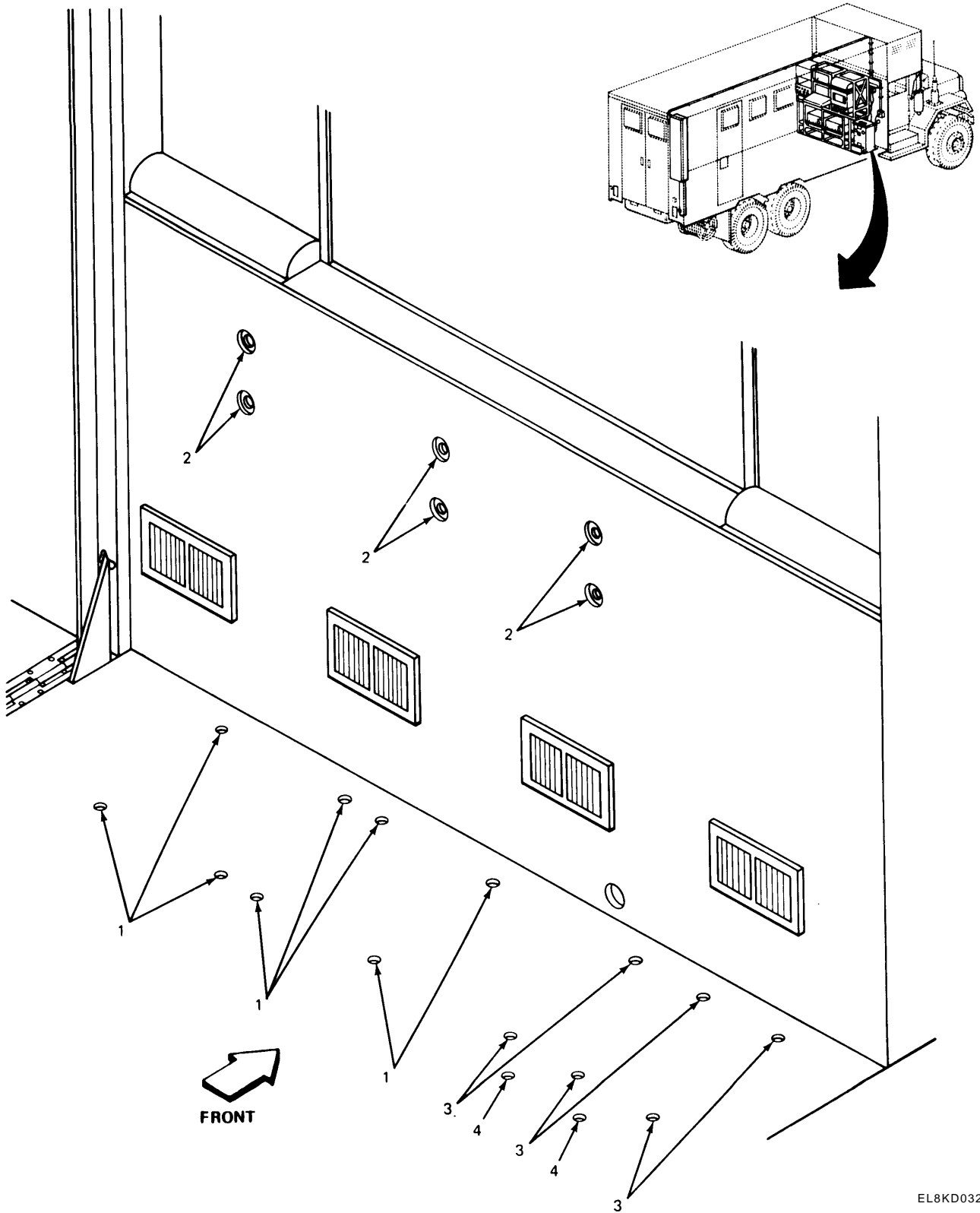

EL8KD032

4-29. INSTALLING PIPE NIPPLE.

This task covers:

Installation

INITIAL SETUP

Tools	Personnel Required
Pliers	One mechanic
Materials/Parts	Equipment Condition
1 1/2-inch pipe nipple Aluminum washer (2 required) 1 1/2-inch conduit locknut (2 required) Silicone sealant 1 1/2-inch insulator bushing (2 required)	Pipe nipple hole predrilled.

LOCATION	ITEM	ACTION REMARKS
----------	------	-------------------

NOTE

Make sure the pipe nipple does not stick outside of forward wall more than 1 inch.

1. Lower forward wall	Pipe nipple (1)	Put pipe nipple into mounting hole.
2. Around pipe nipple	Silicone sealant (2)	Apply.
3. Inside of vehicle on pipe nipple	Aluminum washer (3) and conduit locknut (4)	Install, handtighten.
4. Outside of vehicle on pipe nipple	Aluminum washer (5) and conduit locknut (6)	Install, handtighten.
5. Outside and inside of vehicle on pipe nipple	Conduit locknut (6) and conduit locknut (4)	Using pliers, tighten.
6.	Insulator bushing (7), insulator bushing (8)	Install.

4-29. INSTALLING PIPE NIPPLE. (CONT)

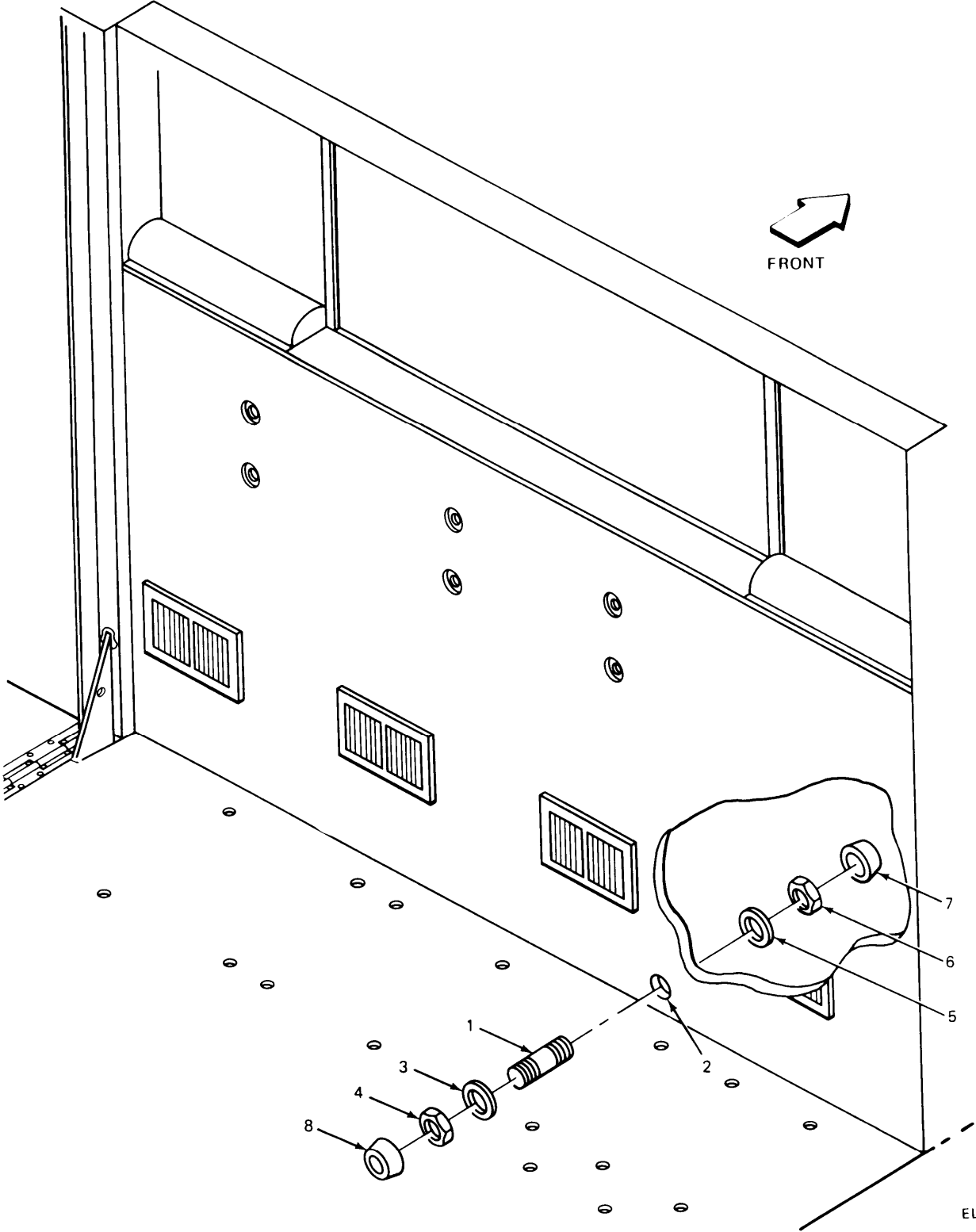

EL8KD033

4-30. INSTALLING TACFIRE RACK.

This task covers:

Installation

INITIAL SETUP

Tools

1/2-inch box wrench

Personnel Required

Two mechanics

Materials/parts

- 5/16-18 x 1 inch long hex head screw (6 required)
- 5/16-18 x 1 1/2 inch long hex head screw (8 required)
- 5/16-inch lockwasher (14 required)
- 5/16-inch flat washer (14 required)

Equipment Condition

Tacfire rack assembled. Mounting holes predrilled. Rivnuts installed.

LOCATION	ITEM	ACTION REMARKS
----------	------	-------------------

NOTE

A helper will be needed to set tacfire rack against forward wall.

1. Forward wall	Tacfire rack (1)	Put tacfire rack against forward wall and aline mounting holes.
2. Radio mount	Screw (2), lock-washer (3) and flat washer (4)	Install, handtighten. There are eight screws. Step 2 is typical for all eight screws.
3.	Screw holes (5)	Do step 2 again.
4. Wall support	Screw (6), lock-washer (7) and flat washer (8)	Install, handtighten. There are six screws. Step 4 is typical for all six screws.
5.	Screw holes (9)	Do step 4 again.

4-30. INSTALLING TACFIRE RACK. (CONT)

LOCATION	ITEM	ACTION REMARKS
6. Radio mount and wall support	Screw (2) and screw (6)	Using 1/2-inch box wrench, tighten. There are fourteen screws. Six wall support screws and eight radio mounting screws. Step 6 is typical for all fourteen screws.
7.	Screw (2) and screw (6)	Do step 6 again.

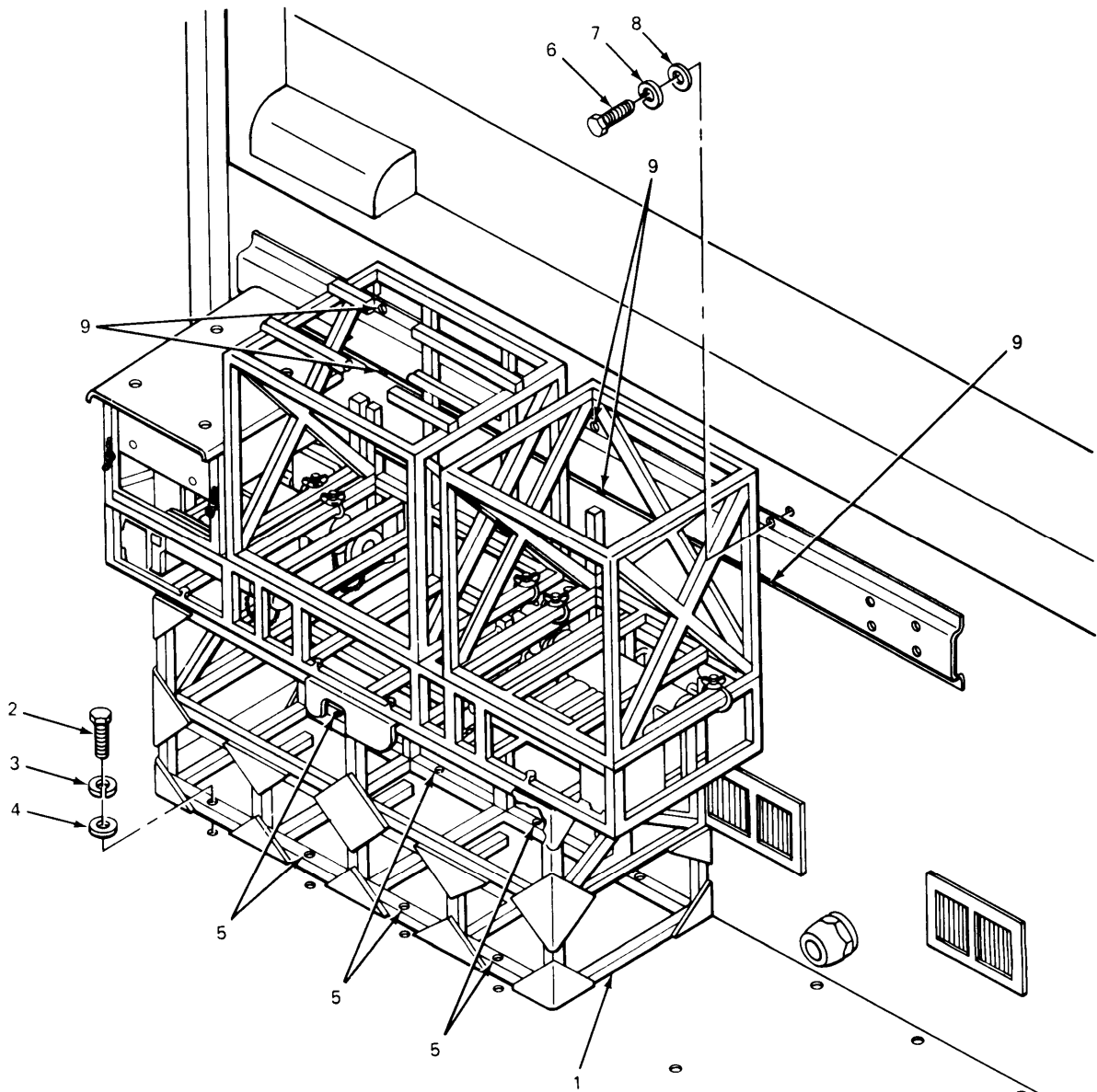

EL8KD034

4-31. INSTALLING RADIO MOUNTING BASES MT-102WRC.

This task covers:

Installation

INITIAL SETUP

Tools

1/2-inch box wrench

Personnel Required

One mechanic

Materials/Parts

5/16-inch lockwasher (10 required)
 5/16-18-inch hex nut (10 required)
 Radio Mounting Base MT-1029/VRC
 (2 required)

Equipment Condition

Tacfire rack installed.

LOCATION	ITEM	ACTION REMARKS
----------	------	-------------------

NOTE

Install radio mounting bases with latches facing out.

1. Roadside of radio mount	Radio mounting base (1) and studs (2)	Put radio mounting base on studs.
2 .	Lockwasher (3) and nut (4)	Using 1/2-inch box wrench, install. There are five studs. Step 2 is typical for all five studs.
3 .	Studs (2)	Do step 2 again.
4. Curbside of radio mount	Radio mounting base (5)	Do steps 1, 2 and 3 again for second radio mounting base.

4-31. INSTALLING RADIO MOUNTING BASES MT-1029/VRC. (CONT)

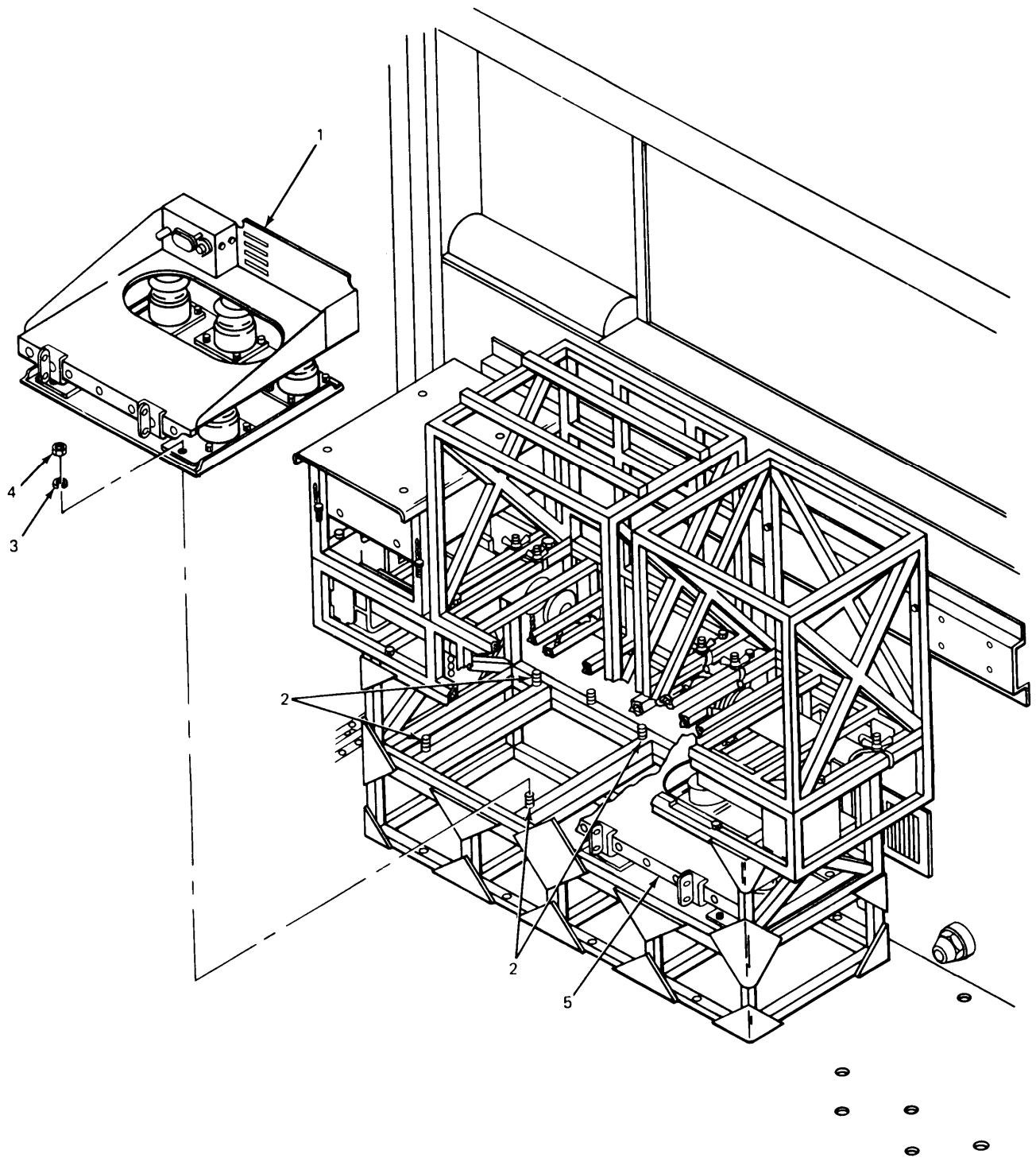

EL8KD035

4-32. INSTALLING TACFIRE COMPONENTS.

This task covers:

Installation

INITIAL SETUP

Tools

Flat-tip screwdriver

Materials/parts

5/16-24 x 1/2 inch long pan head screws
(4 required)
Message entry group
Electronic line printer
Key generator

Personnel Required

Two mechanics

Equipment Condition

Tacfire rack installed.

LOCATION	ITEM	ACTION REMARKS
----------	------	-------------------

NOTE

Carefully slide the tacfire components into place engaging shear pins on rear of racks. This is typical for steps 1 and 2.

1. Electronic line printer rack	Electronic line printer (1)	Install.
---------------------------------	-----------------------------	----------

NOTE

Electronic line printer is secured to an interface mounting base which is bolted to tapped holes in electronic line printer rack. This permits electronic line printer to slide in and out of rack.

2. Message entry group rack	Message entry group (2)	Install.
-----------------------------	-------------------------	----------

4-32. INSTALLING TACFIRE COMPONENTS. (CONT)

LOCATION	ITEM	ACTION REMARKS
3. Key generator rack	Key generator (3) and screw (4)	Using flat-tip screwdriver, install. There are four screws. Step 3 is typical for all four screws.
4.	Screw holes (5)	Do step 3 again.

NOTE

For completion of electronic equipment installation, cabling, connector interface bracket and bonding jumper connections, refer to TM 11-7440-251-10 and TM 11-7440-253-10-1. For installation of radio receiver transmitters refer to SB 11-131.

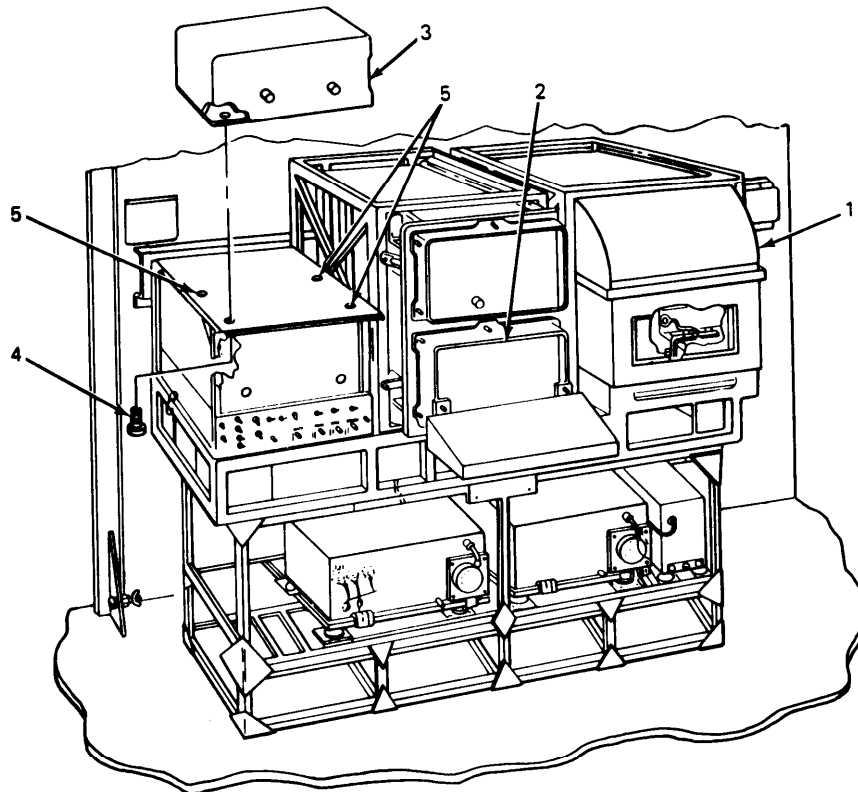

4-33. DC/DC SWITCH.

Installation instructions for DC/DC switch are given in this section.

- Installing DC/DC Switch
- DC/DC Switch routing of cables

4-34. INSTALLING DC/DC SWITCH.

This task covers:

Installation

INITIAL SETUP

Tools

1/2-inch box wrench

Personnel Required

One mechanic

Materials/Parts

- 5/16-24 x 3/4 inch long hex head screws (4 required)
- 5/16-inch lockwasher (4 required)
- 5/16-inch flat washer (4 required)
- DC/DC switch

Equipment Condition

Tacfire rack installed.

LOCATION	ITEM	ACTION REMARKS
1. Curbside, extending wall support	DC/DC switch (1) and wall support (2)	Put DC/DC switch on wall support and aline holes.
2.	Screw (3), lockwasher (4) and flat washer (5)	Install, handtighten. There are four screws. Step 2 is typical for all four screws.
3.	Screw holes (6)	Do step 2 again.
4.	Screw (3)	Using 1/2-inch box wrench, tighten. There are 4 screws. Step 4 is typical for ail four screws.
5.	Screws (3)	Do step 4 again.

4-34. INSTALLING DC/DC SWITCH. (CONT)

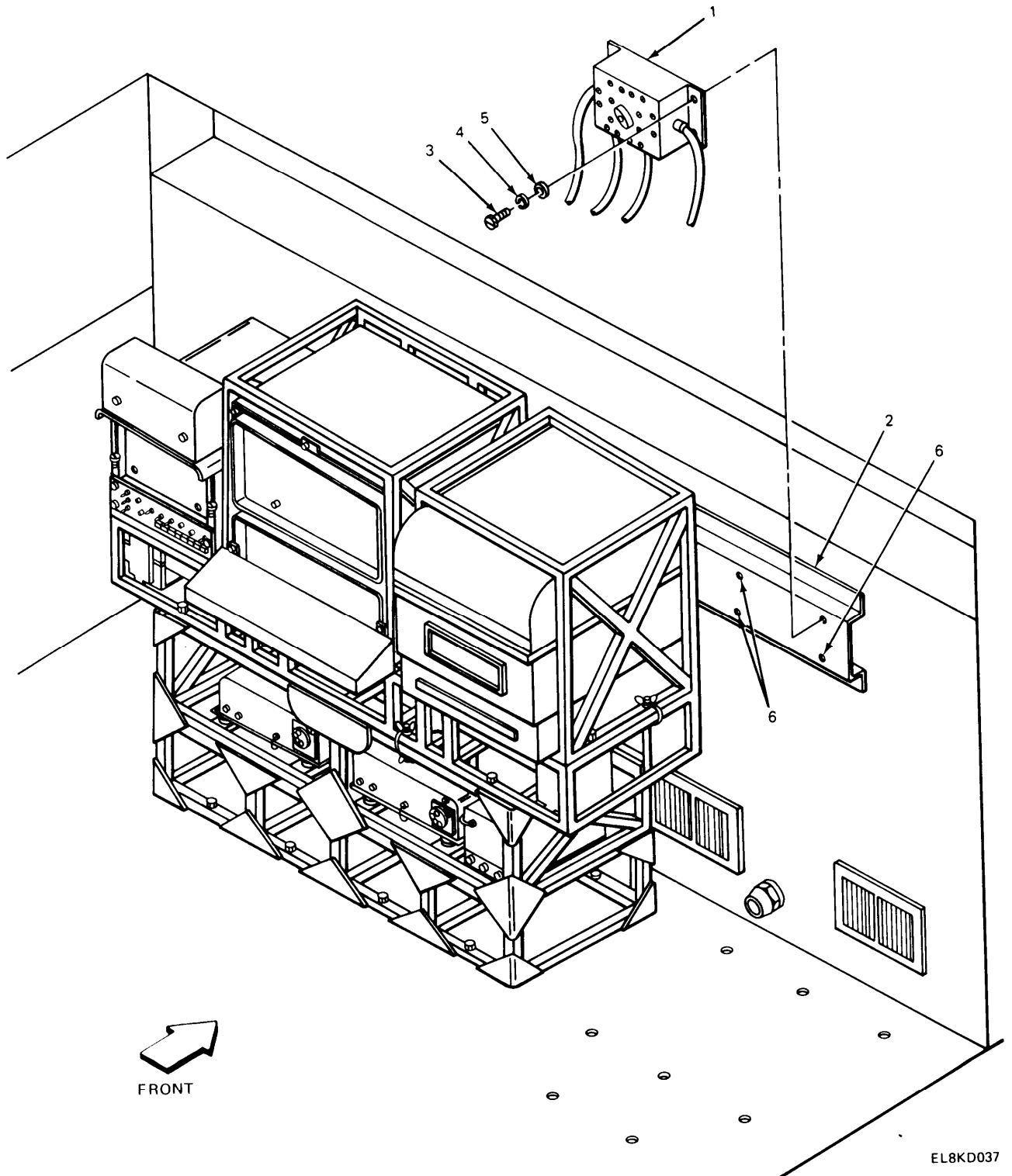

EL8KD037

4-35. DC/DC SWITCH ROUTING OF CABLES.

This task covers:

Routing cables

INITIAL SETUP

Tools

None

Materials/Parts

None

Personnel Required

One mechanic

Equipment Condition

DC/DC switch installed.

LOCATION	ITEM	ACTION REMARKS
1. Roadside of tacfire rack, behind power distribution box	Cable (1)	Route.
2. Behind roadside radio receiver transmitter	Cable (2)	Route.
3. Through pipe nipple to battery box	Cable (3)	Route. Connect as shown in illustration.
4. Around front of power supply	Cable (4)	Route. See positions for power cabling hook-up to battery.

4-35. DC/DC SWITCH ROUTING OF CABLES. (CONT)

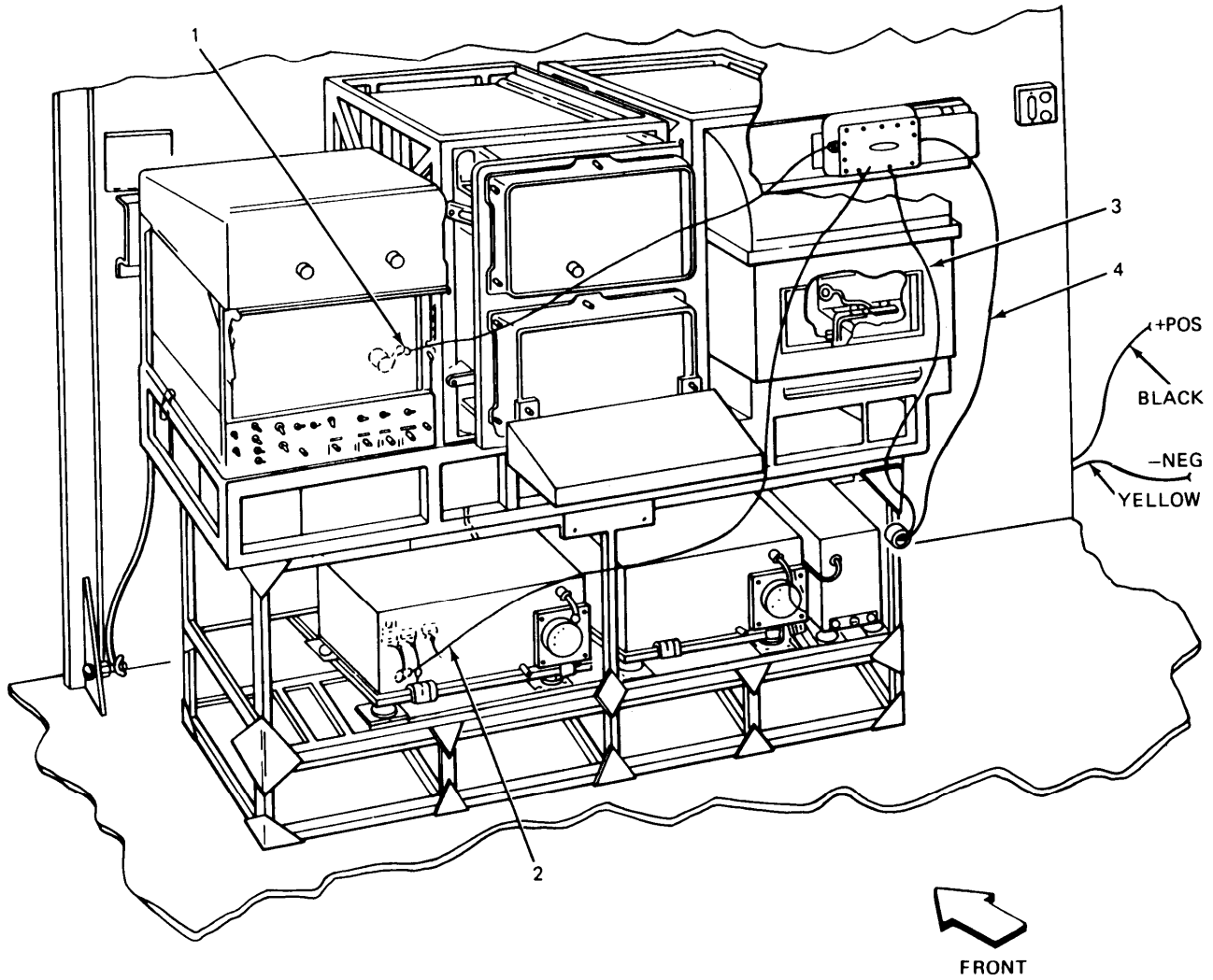

EL8KD038

4-36. INSTALLING 30-INCH GROUND STRAP.

This task covers:

Installation

INITIAL SETUP

Tools

- Pliers
- Flat-tip screwdriver
- 9/16-inch box wrench

Personnel Required

One mechanic

Equipment Condition

Materials/Parts

Gusset predrilled.

- 3/8-16 x 1 1/4 inch long pan head screw
- 3/8-IT lockwasher (6 required)
- 3/8-16 brass hex nut
- 3/8-16 brass wingnut (2 required)
- Grounding strap, 30-inch

LOCATION	ITEM	ACTION REMARKS
1. Rear of power distribution box	Grounding stud (1), IT lockwashers (2), 30-inch ground strap (3) and wingnut (4)	Using pliers, install.
2. Lower gusset plate, roadside position	Screw (5), IT lockwashers (6) and nut (7)	Using flat-tip screwdriver and 9/16-inch box wrench, install.
3. Screw	IT lockwashers (8), 30-inch ground strap (3) and wingnut (9)	Using pliers, install.

4-36. INSTALLING 30-INCH GROUND STRAP. (CONT)

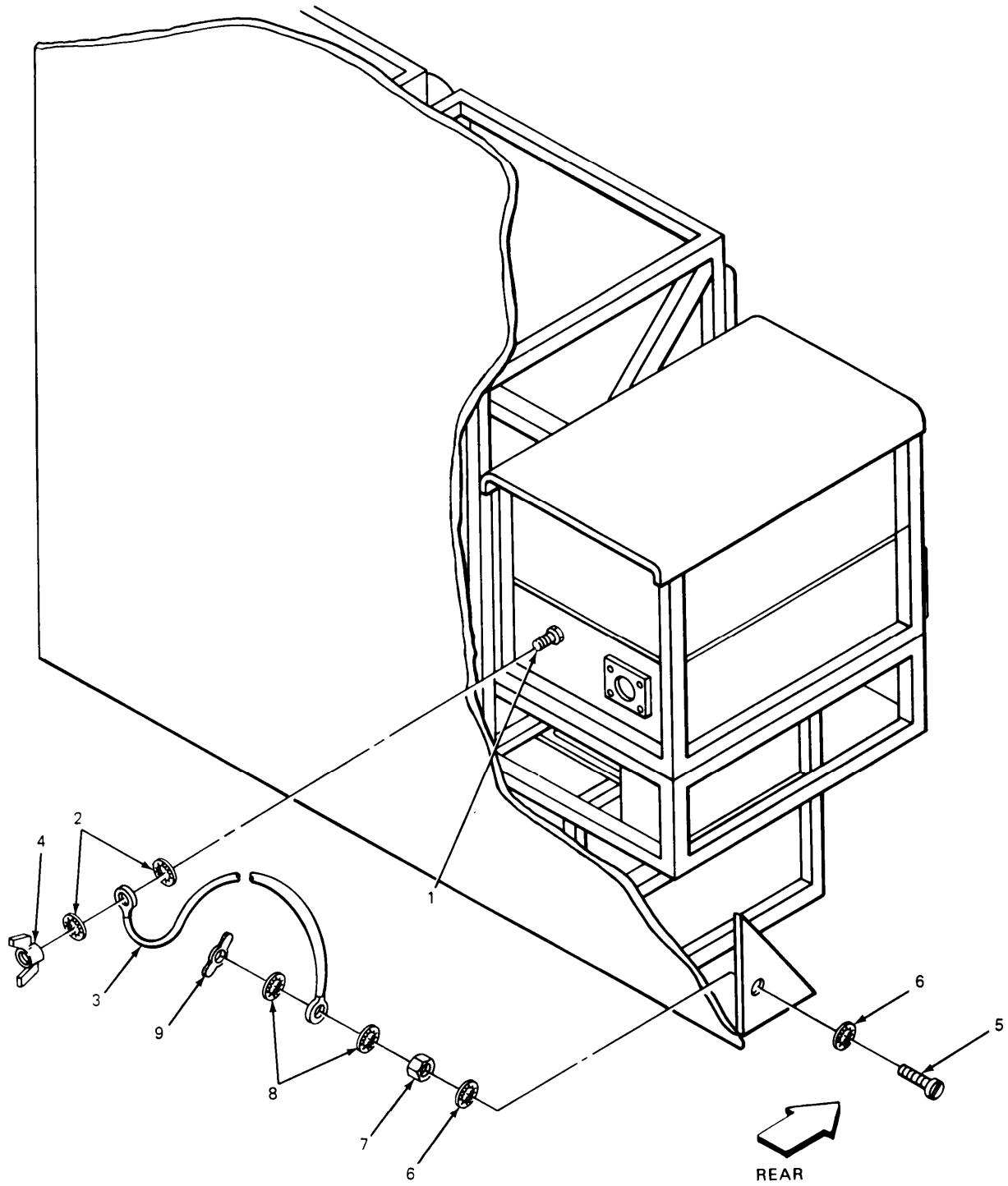

EL8KD039

4-37. CURBSIDE ANTENNA MOUNT.

Installation instructions for mounting curbside antenna are given in this section.

- Installing Antenna Assembly AS-1729/VRC to antenna mount.
- Installing curbside antenna mount
- Routing curbside antenna cables
- Installing curbside antenna cables

4-38. INSTALLING ANTENNA ASSEMBLY AS-1729/VRC TO ANTENNA MOUNT.

This task covers:

Installation

INITIAL SETUP

Tools

- 9/16-inch box wrench
- 7/16-inch box wrench (2 required)
- 3/8-inch box wrench
- 9/16-inch socket
- Ratchet
- 6-inch extension

Materials/Parts

- 3/8-16 x 1 3/4 inch long hex head screw (4 required)
- 3/8-16 nut (4 required)
- 3/8 lockwasher (4 required)
- 3/8 IET lockwasher
- 1/4-28 x 3/4 inch long hex head screw
- 1/4 IET lockwasher (2 required)
- 1/4-28 nut

Materials/Parts (Cont)

- No. 10-32 x 1/2 inch long hex head screw
- No. 10 IET lockwasher (2 required)
- Antenna Assembly AS-1729/VRC
- Antenna mount
- Ground strap
- Cable Assembly RF CX-1773B/U
- Cable Assembly SP CX-4722/VRC

Personnel Required

One mechanic

Equipment Condition

Removed from packing carton.

4-38. INSTALLING ANTENNA ASSEMBLY AS-1729/VRC TO ANTENNA MOUNT. (CONT)

LOCATION	ITEM	ACTION REMARKS
1. Antenna mount	Cable assembly rf (1) and cable assembly sp (2)	Route.
2. Antenna Assembly AS-1729/VRC	Cable assembly rf (1), receptacle J1 (3), cable assembly sp (2) and receptacle J2 (4)	Connect.
3.	Screw (5), IET lockwashers (6), ground strap (7) and grounding stud (8)	Using 3/8-inch box wrench, install.

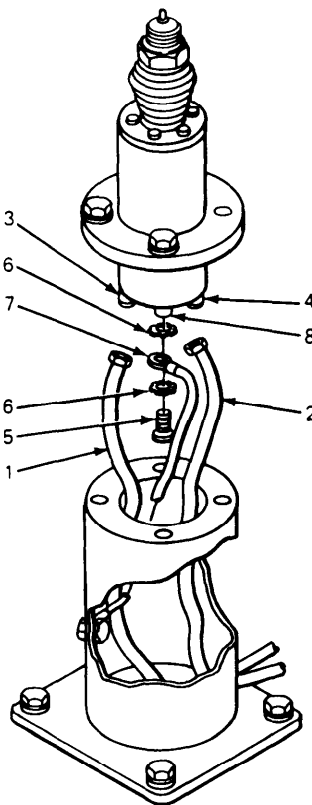

EL8KD040

4-38. INSTALLING ANTENNA ASSEMBLY AS-1729/VRC TO ANTENNA MOUNT. (CONT)

LOCATION	ITEM	ACTION REMARKS
4. Antenna mount	Screw (9), IET lockwashers (10), ground strap (7), and ground hole (11) and nut (12)	Using 7/16-inch box wrench, install.
5.	Antenna assembly (13) and antenna mount (14)	Put antenna assembly on antenna mount and align holes.
6.	Screw (15), IET lockwasher (16), lockwasher (17) and nut (18)	Using 9/16-inch box wrench, 9/16-inch socket, extension and ratchet, install. There are four screws. Step 5 is typical for all four screws.
7.	Screw holes (19)	Do step 5 again.

4-38. INSTALLING ANTENNA ASSEMBLY AS-17291VRC TO ANTENNA MOUNT. (CONT)

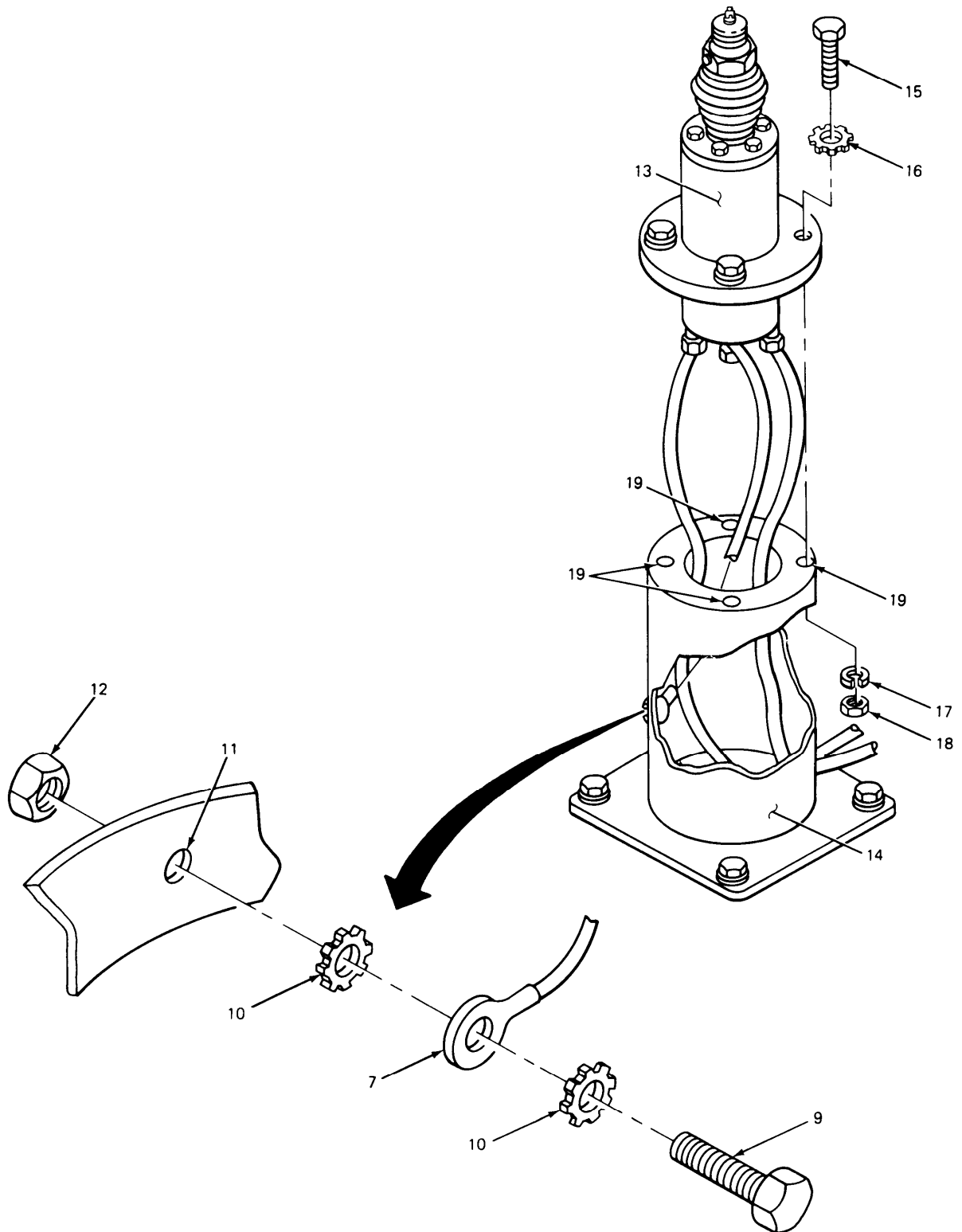

EL8KD041

4-39. INSTALLING CURBSIDE ANTENNA MOUNT ASSEMBLY.

This task covers:

1. Removal
2. Installation

INITIAL SETUP

Tools	Personnel Required
9/16-inch box wrench (2 required)	One mechanic
Materials/Parts	Equipment Condition
Antenna mount assembly	Antenna assembly installed on antenna mount.

LOCATION	ITEM	ACTION REMARKS
----------	------	-------------------

REMOVAL

NOTE

Save all removed hardware for installation of antenna mount.

1. Curbside fender	Screw (1), flat washers (2) and nut (3)	Using two 9/16 inch box wrenches, remove. There are four screws. Step 1 is typical for all four screws.
2.	Screws (4)	Do step 1 again.

INSTALLATION

NOTE

Make sure that cables are facing in toward truck and mounting base does not crimp cables.

1. Curbside fender	Antenna mount (5) and curbside fender (6)	Put antenna mount on curbside fender and align holes.
--------------------	---	---

4-39. INSTALLING CURBSIDE ANTENNA MOUNT ASSEMBLY. (CONT)

LOCATION	ITEM	ACTION REMARKS
INSTALLATION (CONT)		
2. Curbside fender	Screw (1), flat washers (2) and nut (3)	Install, handtighten. There are four screws. Step 2 is typical for all four screws.
3.	Screw holes (7)	Do step 2 again.
4.	Screw (1) and nut (3)	Using two 9/16-inch box wrenches, remove. There are four screws. Step 4 is typical for all four screws.
5.	Screws (1) and nuts (3)	Do step 4 again.

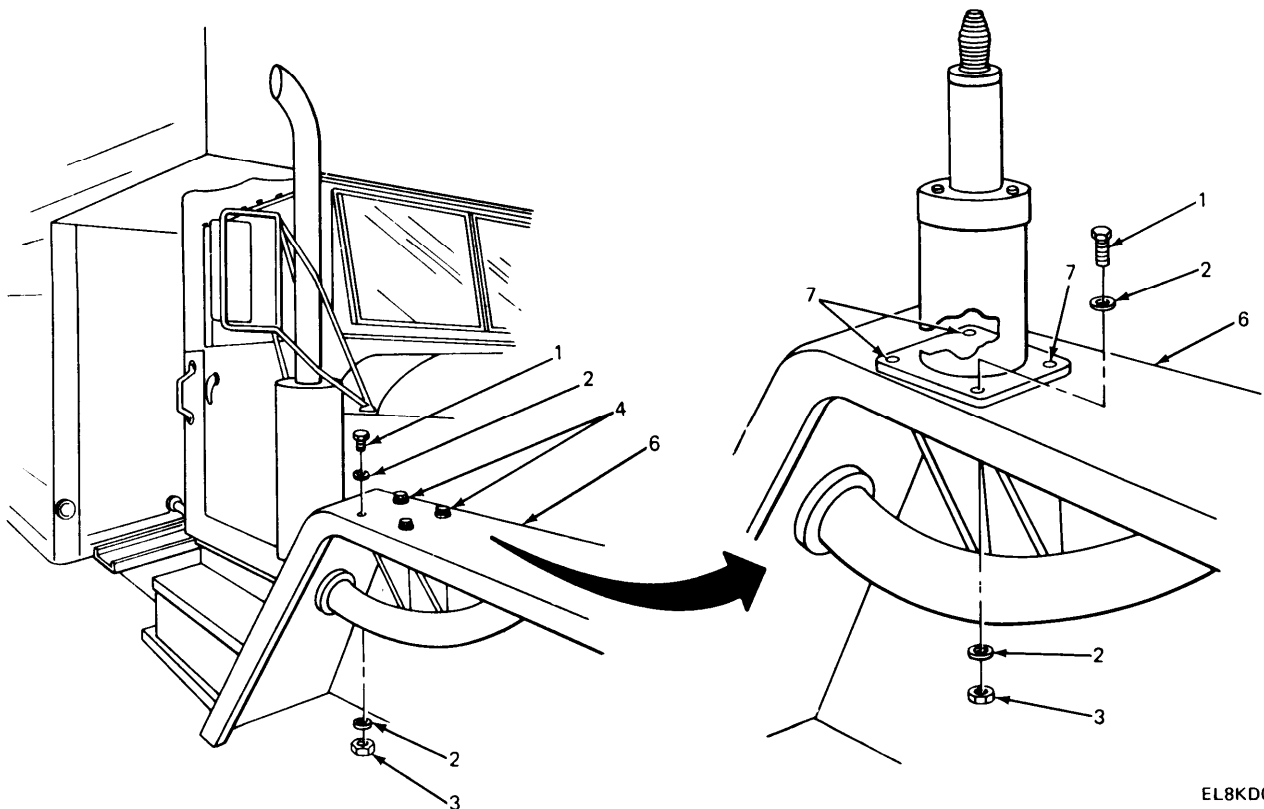

EL8KD042

4-40. ROUTING CURBSIDE ANTENNA CABLES.

This task covers:

Routing

INITIAL SETUP

Tools

None

Personnel Required

One mechanic

Materials/Parts

None

Equipment Condition

Antenna mounted on curbside fender with cables.

LOCATION	ITEM	ACTION REMARKS
----------	------	-------------------

NOTE

Route antenna cable down fender close to body, under door, under spare tire, and thru pipe nipple.

Curbside

Antenna
cables (1)

Route.

4-40. ROUTING CURBSIDE ANTENNA CABLES. (CONT)

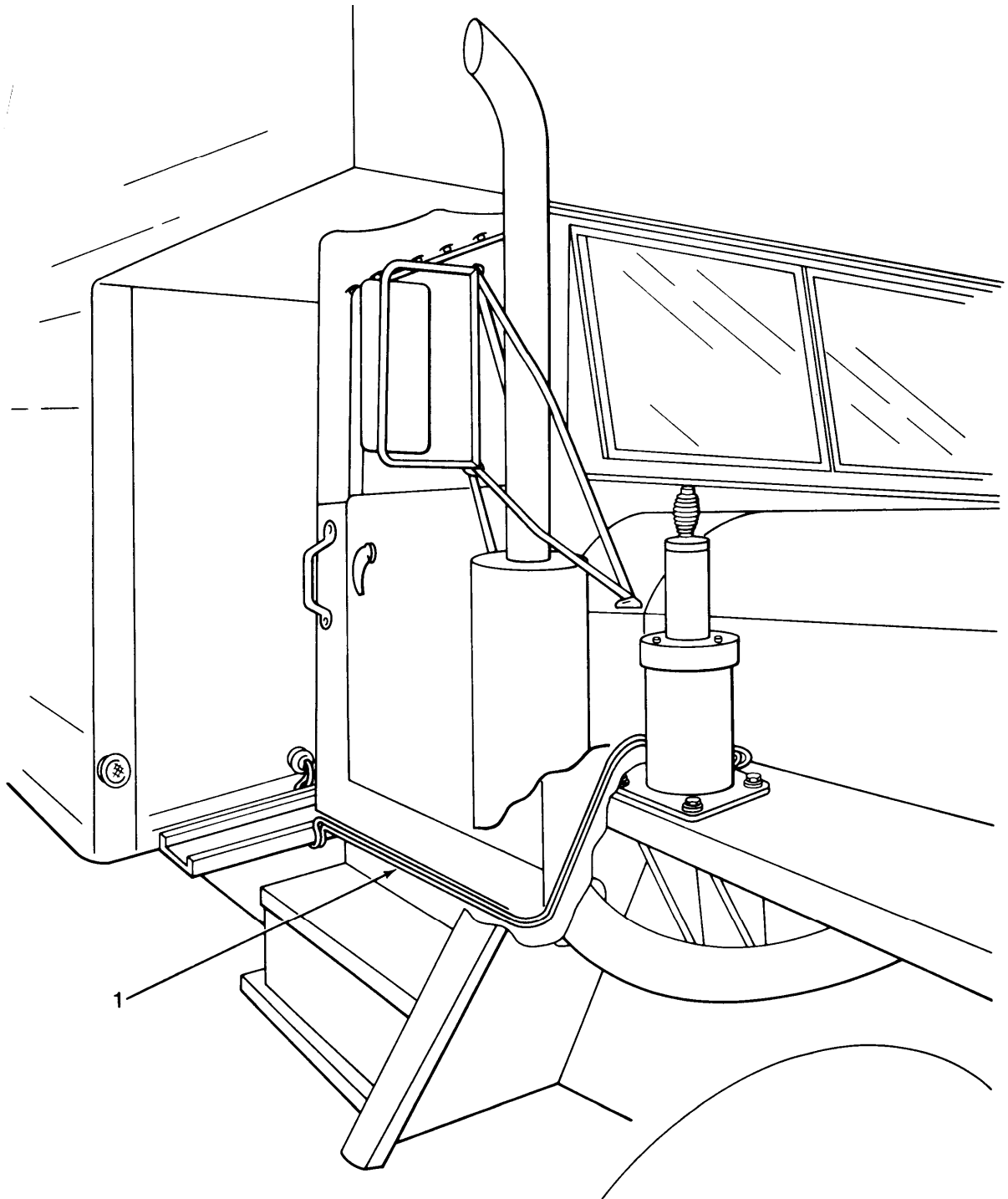

EL8KD043

4-41. INSTALLING CURBSIDE ANTENNA CABLES.

This task covers:

Installation

INITIAL SETUP

Tools

Flat-tip screwdriver

Personnel Required

One mechanic

Materials/Parts

Cable clamps (3 required)
 1-inch sheet metal screws
 (3 required)
 Nylon ties (as required)

Equipment Condition

Antenna cable routed, mounting
 holes predrilled.

LOCATION	ITEM	ACTION	REMARKS
----------	------	--------	---------

NOTE

Once cable is routed, secure in position pulling cable tight.

1. Curbside	Cable clamp (1), screw (2) and antenna cables (3)	Using flat-tip screwdriver, install.	There are three cable clamps. Step 1 is typical for all three cable clamps.
2.	Cable clamps (4)	Do step 1 again.	
3.	Nylon tie (5)	Install.	There are three nylon ties. Secure antenna cables with nylon ties where possible. Step 3 is typical for all three nylon ties.
4.	Nylon ties (6)	Do step 3 again.	

NOTE

For antenna cable connections refer to SB 11-131.

4-41. INSTALLING CURBSIDE ANTENNA CABLES. (CONT)

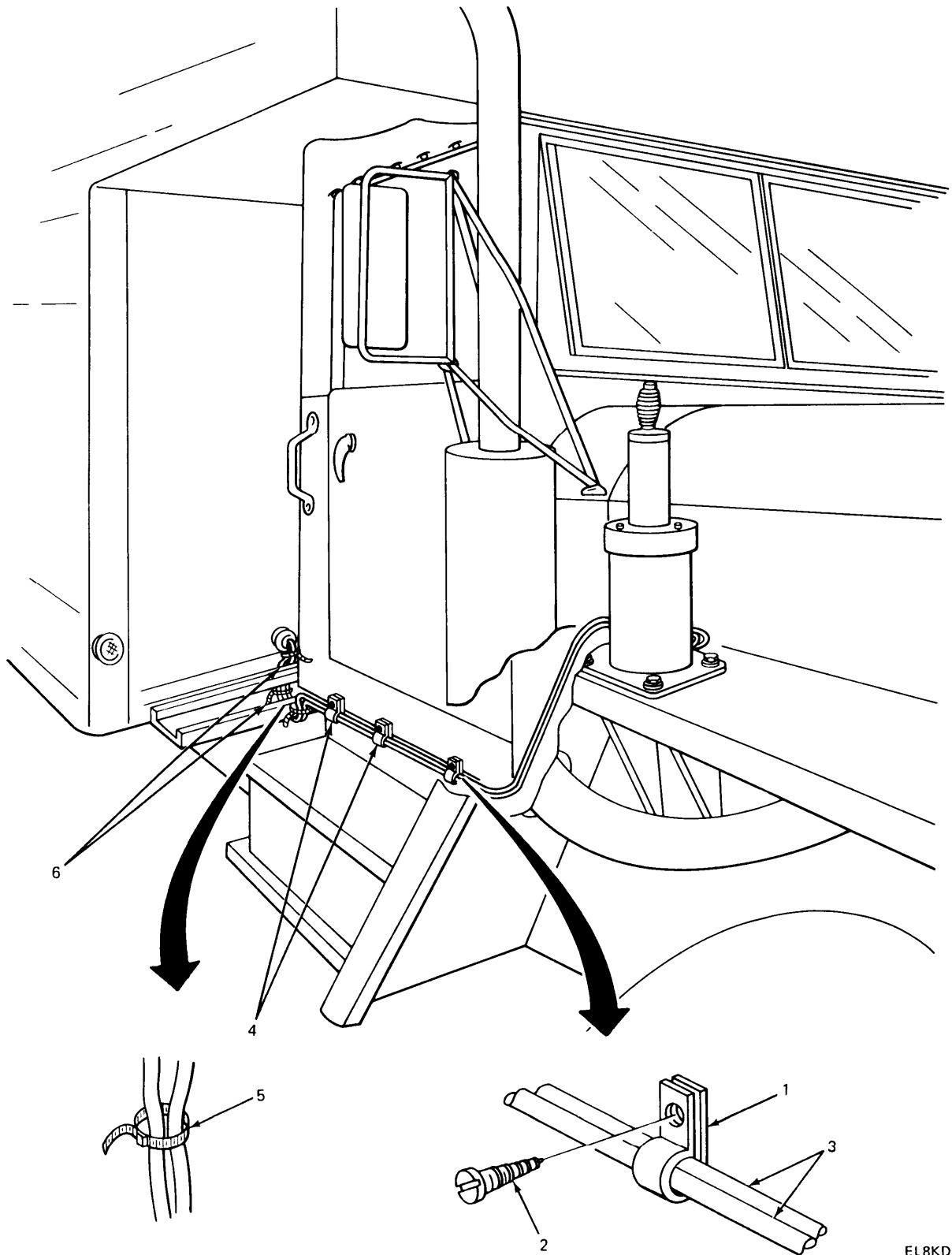

EL8KD044

4-42. ROADSIDE ANTENNA MOUNT.

Installation instructions for mounting roadside antenna are given in this section.

- Installing antenna assembly AS-1729/VRC
- Installing roadside antenna mount assembly
- Routing roadside antenna cable
- Installing roadside antenna cables

4-43. INSTALLING ANTENNA ASSEMBLY AS-1729/VRC TO ANTENNA MOUNT.

This task covers:

Installation

INITIAL SETUP

Tools

- 9/16-inch box wrench
- 7/16-inch box wrench
(2 required)
- 3/8-inch box wrench
- 9/16-inch socket
- Ratchet
- Extension

Materials/Parts

- 3/8-16 x 1/34 inch long hex
head screw (4 required)
- 3/8-16 nut (4 required)
- 3/8 lockwasher (4 required)
- 3/8 IET lockwasher
- 1/4-28 x 3/4 inch hex head
screw
- 1/4 IET lockwasher (2 required)
- 1/4-28 nut

Materials/Parts (Cont)

- No. 10-32 x 1/2 inch long hex
head screw
- No. 10 IET lockwasher
(2 required)
- Antenna Assembly AS-1729/VRC
- Antenna mount
- Ground strap
- Cable Assembly RF CX-1773B/U
- Cable Assembly SP CX-4722/VRC

Personnel Required

One mechanic

Equipment Condition

Removed from packing cartons.

NOTE

Steps for installing antenna assembly to antenna mount are typical for roadside and curbside.

4-43. INSTALLING ANTENNA ASSEMBLY AS-1729/VRC TO ANTENNA MOUNT. (CONT)

LOCATION	ITEM	ACTION REMARKS
1. Antenna mount	Cable assembly rf (1) and cable assembly sp (2)	Route.
2. Antenna Assembly AS-1729/VRC	Cable assembly rf (1), receptacle J1 (3), cable assembly sp (2) and receptacle J2 (4)	Connect.
3.	Screw (5), IET lockwashers (6), ground strap (7) and grounding stud (8)	Using 3/8-inch box wrench, install.

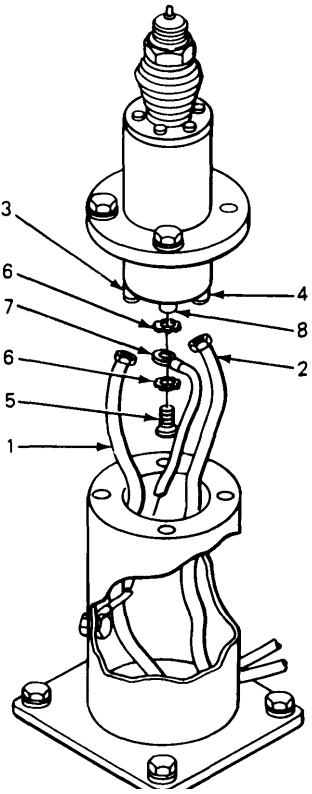

TYPICAL
(ROADSIDE AND CURBSIDE)

EL8KD045

4-43. INSTALLING ANTENNA ASSEMBLY AS-1729/VRC TO ANTENNA MOUNT. (CONT)

LOCATION	ITEM	ACTION REMARKS
4. Antenna mount	Screw (9), IET lockwashers (10), ground strap (7) and ground hole (11) and nut (12)	Using 7/16-inch box wrench, install.
5.	Antenna assembly (13) and antenna mount (14)	Put antenna assembly on antenna mount and align holes.
6.	Screw (15), IET lockwasher (16), lockwasher (17) and nut (18)	Using 9/16-inch box wrench, 9/16-inch socket, extension and ratchet, install. There are four screws. Step 5 is typical for all four screws.
7.	Screw holes (19)	Do step 5 again.

4-43. INSTALLING ANTENNA ASSEMBLY AS-17291VRC TO ANTENNA MOUNT. (CONT)

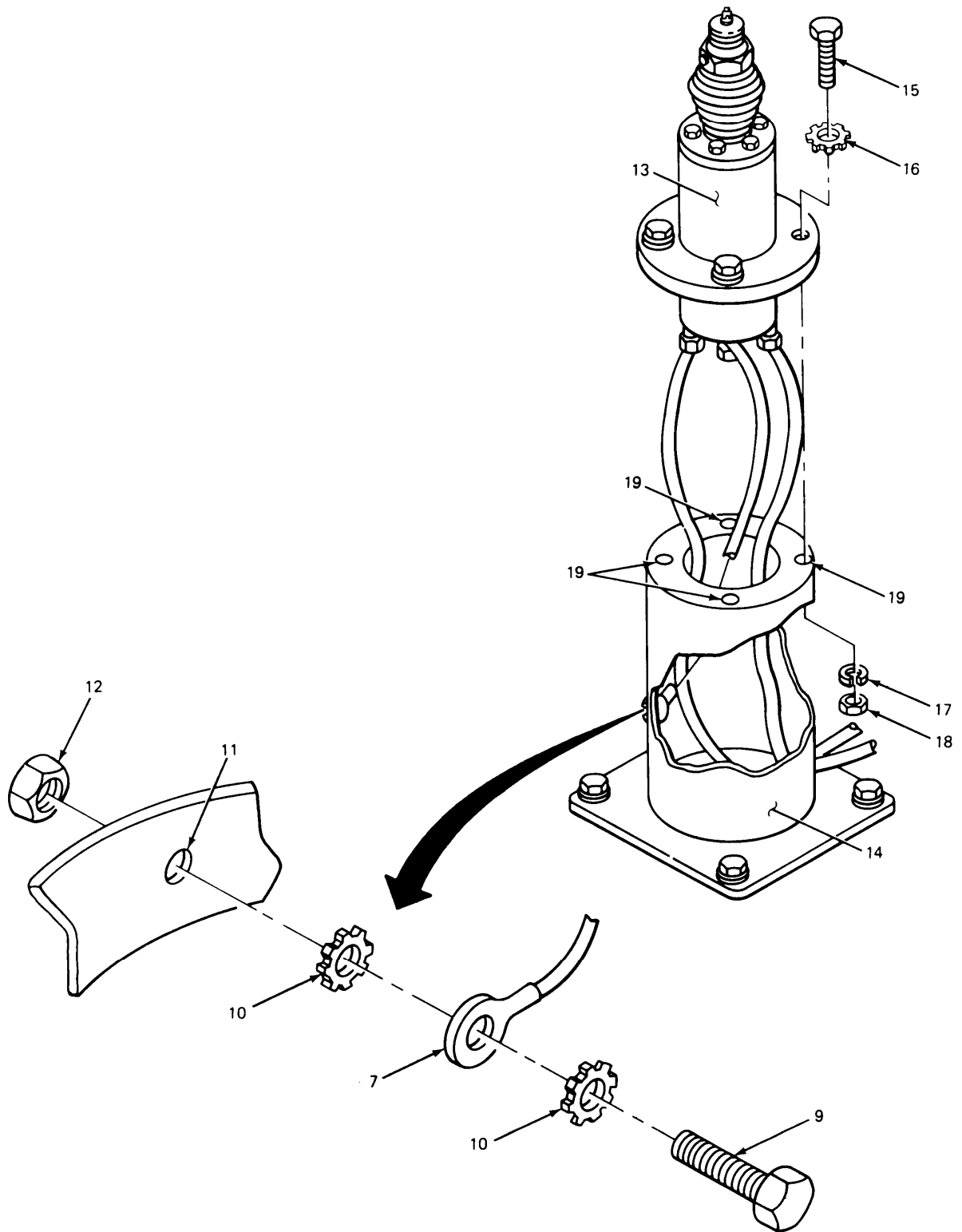

EL8KD046

4-44. INSTALLING ROADSIDE ANTENNA MOUNT ASSEMBLY.

This task covers:

1. Removal
 2. Installation
-

INITIAL SETUP

Tools	Personnel Required
9/16-inch box wrench (2 required)	One mechanic
Materials/Parts	Equipment Condition
Antenna mount assembly	Antenna assembly installed on antenna mount.

LOCATION	ITEM	ACTION REMARKS
----------	------	-------------------

REMOVAL

NOTE

Save all removed hardware for installation of antenna mount.

- | | | |
|--------------------|---|---|
| 1. Roadside fender | Screw (1), flat washers (2) and nut (3) | Using two 9/16-inch box wrenches, remove.
There are four screws. Step 1 is typical for all four screws. |
| 2. | Screws (4) | Do step 1 again. |

INSTALLATION

NOTE

Make sure that cables are facing in toward truck and mounting base does not crimp cables.

- | | | |
|--------------------|---|---|
| 1. Roadside fender | Antenna mount (5) and curbside fender (6) | Put antenna mount on curbside fender and align holes. |
|--------------------|---|---|

4-44. INSTALLING ROADSIDE ANTENNA MOUNT ASSEMBLY. (CONT)

LOCATION	ITEM	ACTION REMARKS
INSTALLATION (CONT)		
2. Roadside fender	Screw (1), flat washers (2) and nut (3)	Install, handtighten. There are four screws. Step 2 is typical for all four screws.
3.	Screw holes (7)	Do step 2 again.
4.	Screw (1) and nut (3)	Using two 9/16-inch box wrenches, tighten. There are four screws. Step 4 is typical for all four screws.
5.	Screws (1) and nuts (3)	Do step 4 again.

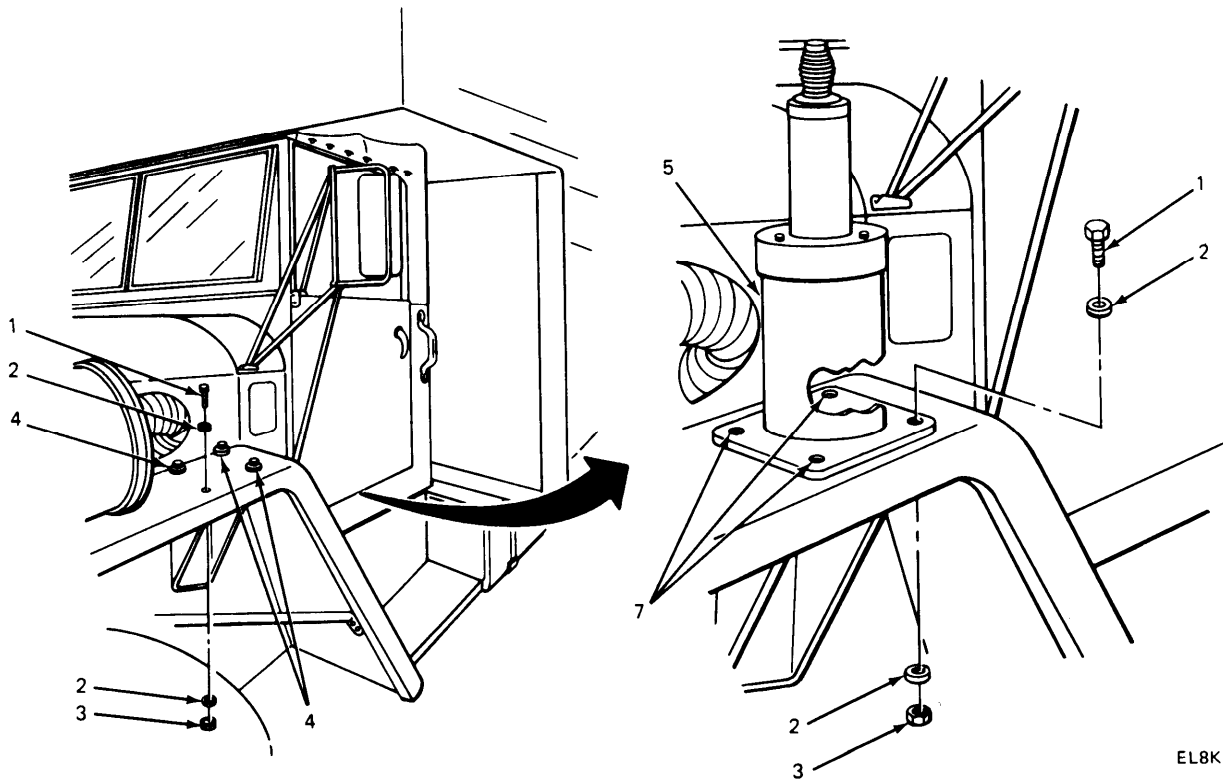

EL8KD047

4-45. ROUTING ROADSIDE ANTENNA CABLES.

This task covers:

Routing

INITIAL SETUP

Tools

None

Materials/Parts

None

Personnel Required

One mechanic

Equipment Condition

Antenna mounted on roadside fender.

LOCATION	ITEM	ACTION REMARKS
----------	------	-------------------

NOTE

Route antenna cables down fender close to body, under door, across vehicle between truck body and cab, behind spare tire and thru pipe nipple.

Roadside	Antenna cable (1)	Route.
----------	-------------------	--------

4-45. ROUTING ROADSIDE ANTENNA CABLES. (CONT)

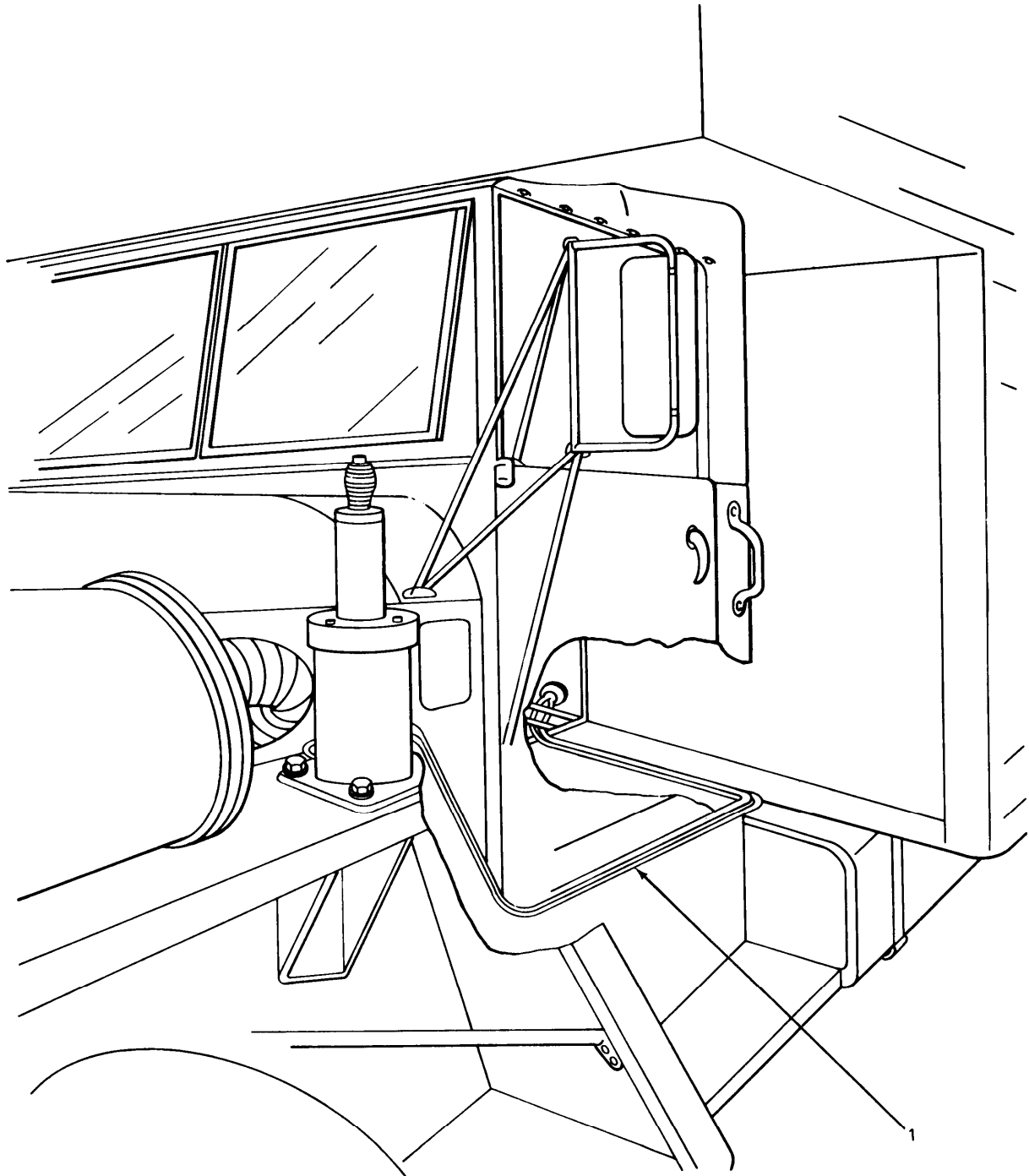

EL8KD048

4-46. INSTALLING ROADSIDE ANTENNA CABLES.

This task covers:

Installation

INITIAL SETUP

Tools

Flat-tip screwdriver

Personnel Required

One mechanic

Materials/Parts

Cable clamps (3 required)
 1-inch sheet metal screws
 (3 required)
 Nylon ties (3 required)

Equipment Condition

Antenna cable routed, mounting
 holes predrilled.

LOCATION	ITEM	ACTION REMARKS
----------	------	-------------------

NOTE

Once cable is routed, secure in position pulling cable tight.

1. Roadside	Cable clamp (1), screw (2) and antenna cables (3)	Using flat-tip screwdriver, install. There are three cable clamps. Step 1 is typical for all three cable clamps.
2.	Cable clamps (4)	Do step 1 again.
3.	Nylon tie (5)	Install. There are three nylon ties. Secure antenna cables with nylon ties where possible. Step 3 is typical for all three nylon ties.
4.	Nylon ties (6)	Do step 3 again.

NOTE

For antenna cable connections refer to SB 11-131.

4-46. INSTALLING ROADSIDE ANTENNA CABLES. (CONT)

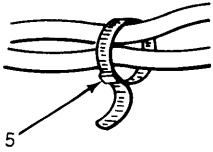
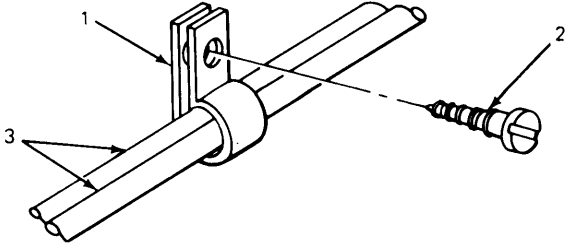
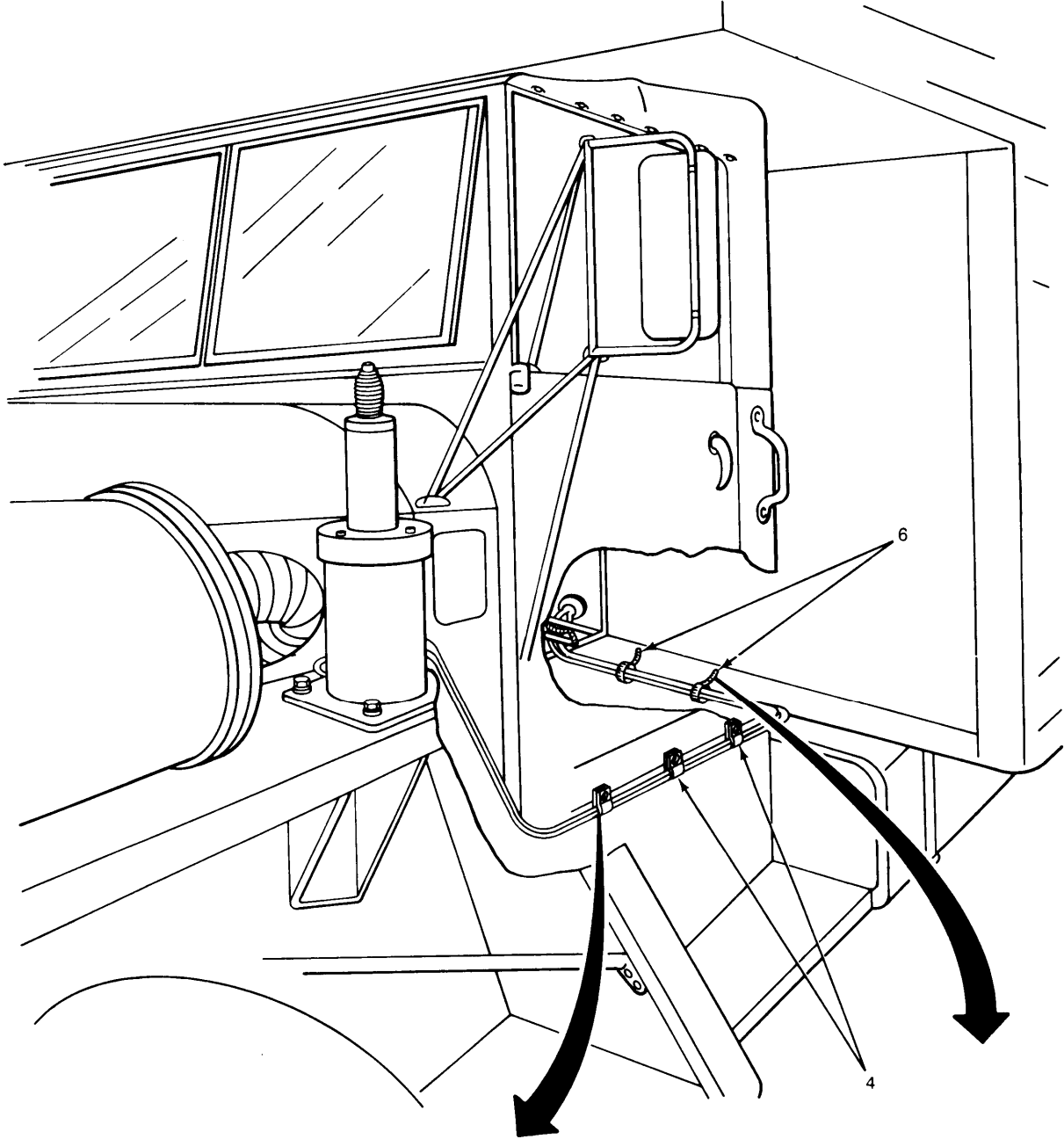

EL8KD049

4-47. INSTALLING CURBSIDE AND ROADSIDE ANTENNA MASTS.

This task covers:

Installation

INITIAL SETUP

Tools

- 1/16-inch hex wrench
- 1-inch open end wrench
- Wire cutters

Personnel Required

One mechanic

Equipment Condition

Materials/Parts

- Antenna mast (3 required)
- Lock wire
- Electrical tape

Antenna mount assembly installed.

LOCATION	ITEM	ACTION REMARKS
1. Front curbside position on top of fender	Antenna mounting base (1), setscrew (2) and electrical contact (3)	Pull electrical contact up out of antenna mounting base as far as it will go. Using hex wrench, tighten setscrew until resistance is felt.
2. Antenna mounting base	O-ring (4)	Install.

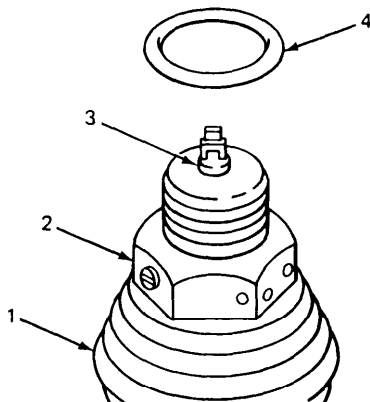

EL8KD050

4-47. INSTALLING CURBSIDE AND ROADSIDE ANTENNA MASTS. (CONT)

LOCATION	ITEM	ACTION REMARKS
3. Front curbside position on top of fender	Upper antenna mast (1), lower antenna mast (2) and electrical tape (3)	Screw upper antenna mast clockwise into lower antenna mast. Wrap two turns of electrical tape where upper and lower antenna masts meet.
4.	Antenna mast (4), electrical contact (5) and mounting base (6)	Using open end wrench, install. Antenna mast will seat against antenna mounting base. Slight resistance will be felt as electrical contact seats against antenna mast.

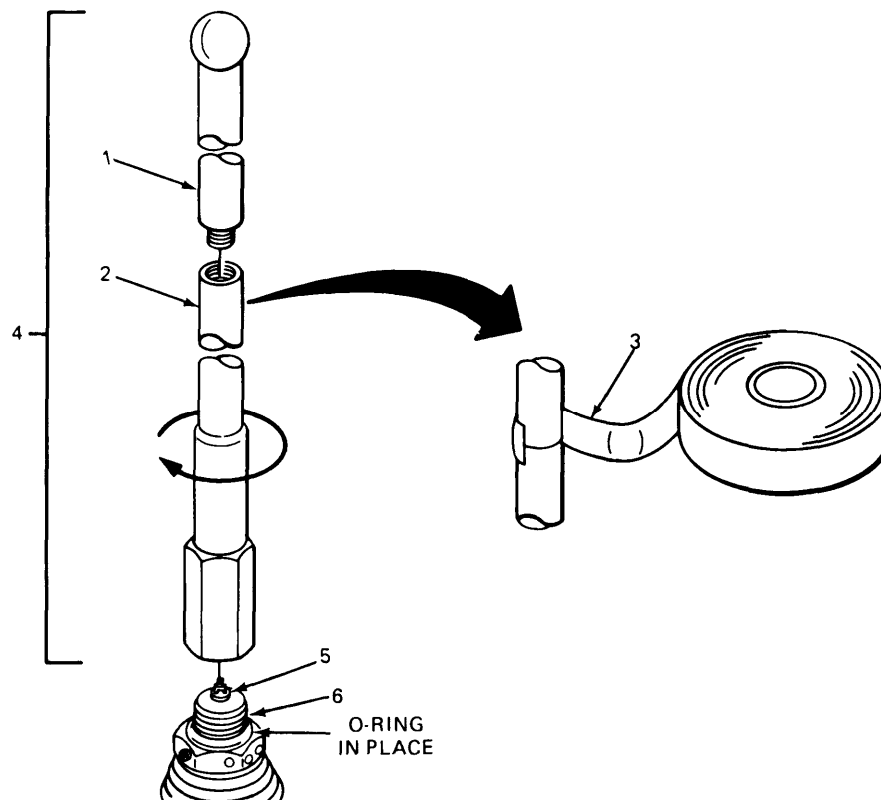

EL8KD051

4-47. INSTALLING CURBSIDE AND ROADSIDE ANTENNA MASTS. (CONT)

LOCATION	ITEM	ACTION REMARKS
5. Front curbside position on top of fender	Setscrew (1)	Using hex wrench, tighten.
6.	Lock wire (2)	Install. Using cutting pliers, clip off wire ends. Install lock wire through upper and lower holes and twist together.

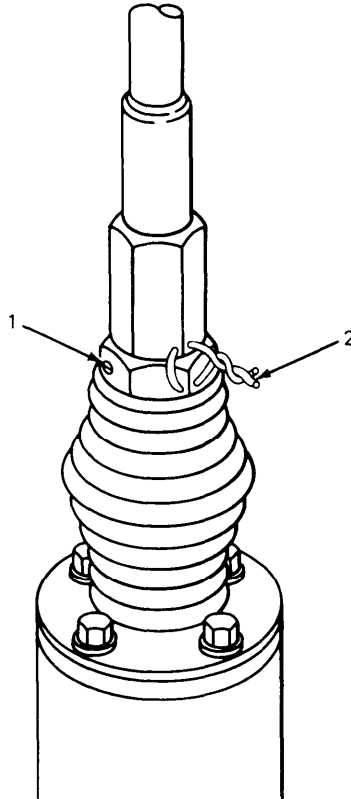

EL8KD052

4-47. INSTALLING CURBSIDE AND ROADSIDE ANTENNA MASTS. (CONT)

LOCATION	ITEM	ACTION REMARKS
7. Front roadside position on top of fender	Antenna mounting base (1), setscrew (2), electrical contact (3), O-ring (4), upper antenna mast (5), lower antenna mast (6), electrical tape (7), antenna mast (8) and lock wire (9)	Do steps 1 thru 6 again.

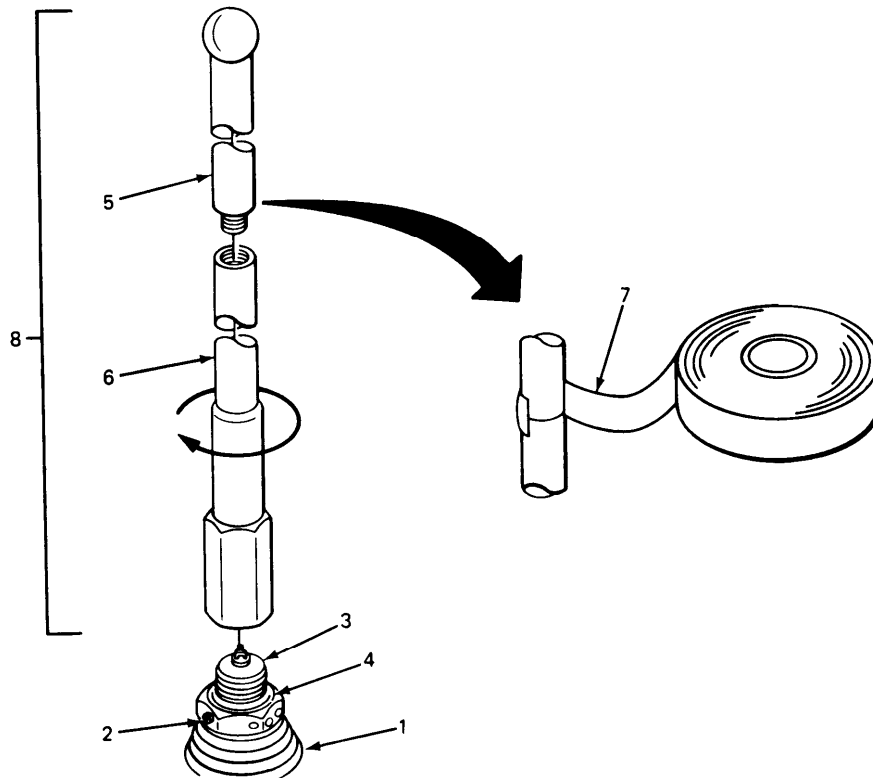

EL8KD053

4-48. INSTALLING CIRCUIT BREAKER AND 90° CABLE CONNECTOR.

This task covers:

Installation

INITIAL SETUP

Tools

- Pliers
- Flat-tip screwdriver

Materials/Parts

- 90° cable connector
- Conduit locknut
- 30 amp single pole circuit breaker

Personnel Required

One mechanic

Equipment Condition

Power to circuit breaker box off.

LOCATION	ITEM	ACTION REMARKS
----------	------	-------------------

WARNING

Make sure power to circuit breaker box is off.

1.	Curbside on rear wall	Screws (1) and circuit breaker box cover (2)	Remove.
2.	Circuit breaker No. 19	Screw (3) and circuit breaker (4)	Using flat-tip screwdriver, install.
3.	Roadside of circuit breaker box	Cable connector (5) and conduit locknut (6)	Using pliers, install. Cable opening faces toward ceiling.

4-48. INSTALLING CIRCUIT BREAKER AND 90° CABLE CONNECTOR. (CONT)

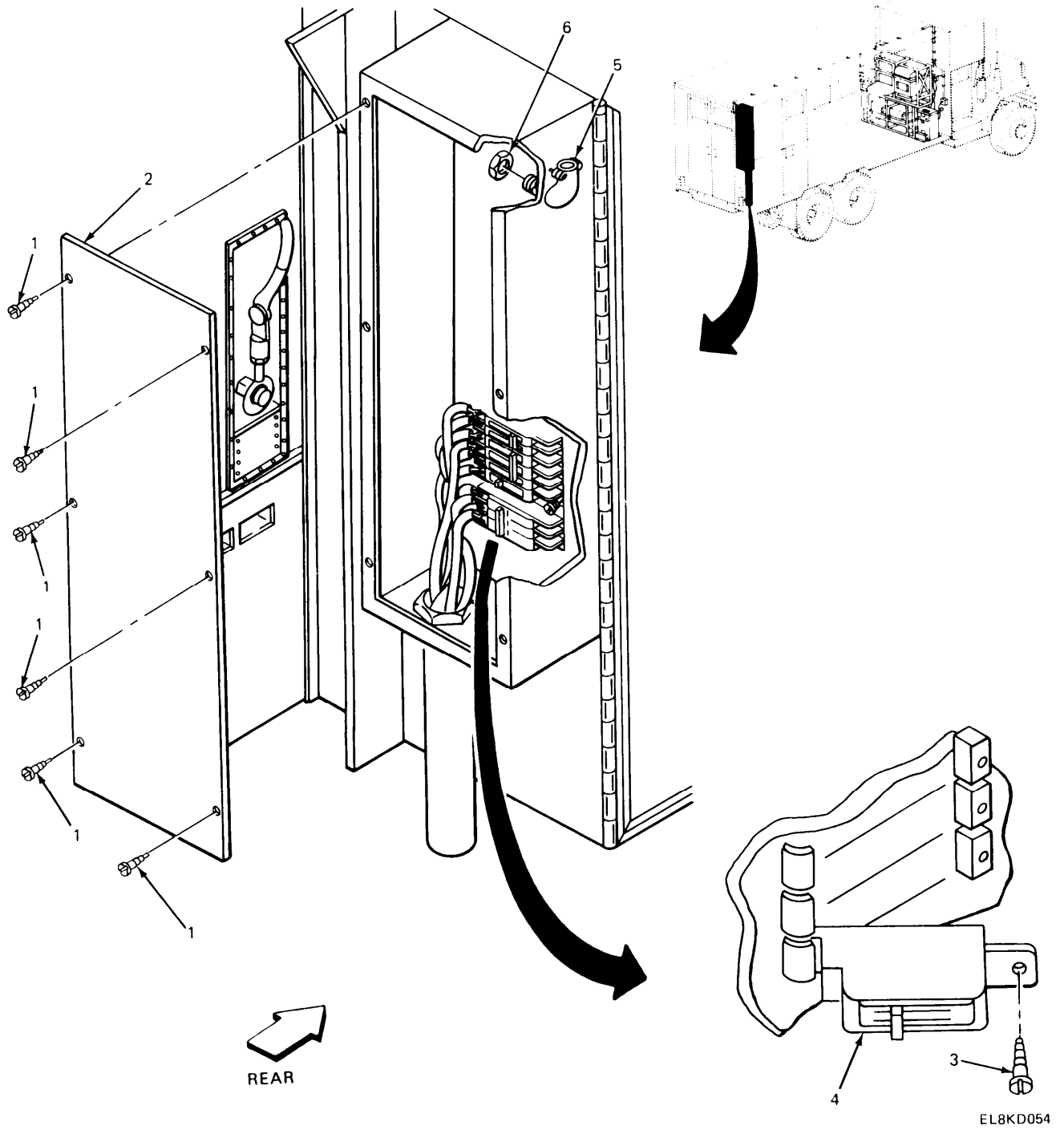

4-49. POWER CABLE.

Installation instructions for power cable are given in this section.

Installing power cable to circuit breaker box
 Routing and fastening power cable

4-50. INSTALLING POWER CABLE TO CIRCUIT BREAKER BOX.

This task covers:

1. Preparation
2. Installation

INITIAL SETUP

<p>Tools</p> <p>Wire strippers Xacto knife Flat-tip screwdriver 25-watt soldering iron</p> <p>Materials/Parts</p> <p>Power cable 26 feet long Solder Power cable Terminal lug</p>	<p>Materials/Parts - (Cont)</p> <p>1/4-inch terminal end</p> <p>Personnel Required</p> <p>One mechanic</p> <p>Equipment Condition</p> <p>Power to circuit breaker box off. 90° cable connector installed.</p>
---	---

LOCATION	ITEM	ACTION REMARKS
----------	------	-------------------

PREPARATION

NOTE

The power cable consists of three insulated wires covered by an outer insulation.

- | | | |
|----------------|---|--|
| 1. Power cable | Outer insulation (1) | Using wire strippers, strip 36 inches of outer insulation. |
| 2. | Black wire (2), white wire (3) and green wire (4) | Using wire strippers, strip 5/8 inch of insulation from each wire. |

4-50. INSTALLING POWER CABLE TO CIRCUIT BREAKER BOX. (CONT)

LOCATION	ITEM	ACTION REMARKS
----------	------	-------------------

PREPARATION (CONT)

WARNING

Soldering iron is hot and can cause severe burns. Use caution while soldering.

- | | | |
|----|--------------------------------|---|
| 3. | Green wire
stripped end (5) | Using soldering iron, apply heat. |
| 4. | Green wire
stripped end (5) | Apply solder.
When solder flows evenly, remove heat. |
| 5. | Green wire
stripped end | Terminal lug (6)
Install. |
| 6. | Terminal lug
end (7) | Apply heat. |
| 7. | Terminal lug
end (7) | Apply solder.
When solder flows evenly on wire end and terminal lug remove heat. |

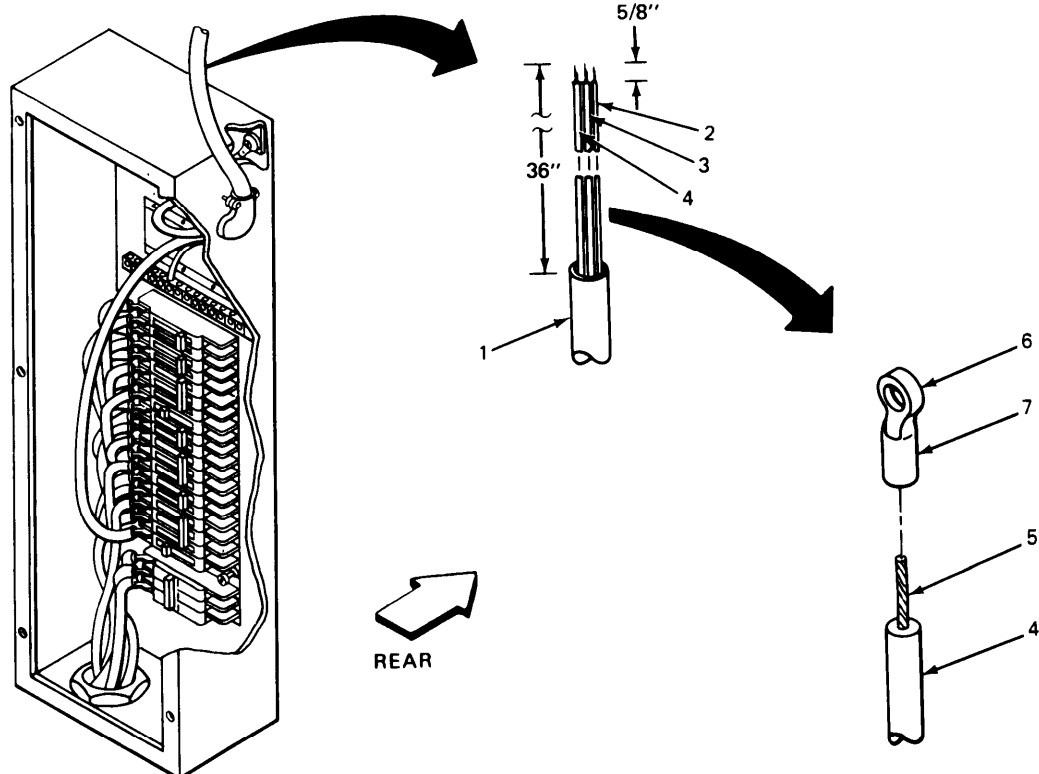

EL8KD055

4-50. INSTALLING POWER CABLE TO CIRCUIT BREAKER BOX. (CONT)

LOCATION	ITEM	ACTION REMARKS
INSTALLATION		
1. 90° cable connector	Power cable (1) and screws (2)	Using flat-tip screwdriver, install. Insert power cable until 1 inch of Outer insulation enters 90° cable connector.
2. Circuit breaker No. 19	Black wire (3) and screw (4)	Using flat-tip screwdriver, install.
3. Neutral strip	White wire (5) and screw (6)	Using flat-tip screwdriver, install.
4. Grounding block	Green wire (7) and screw (8)	Using flat-tip screwdriver, install.
5. Circuit breaker box	Circuit breaker box cover (9) and screws (10)	Using flat-tip screwdriver, install.

4-50. INSTALLING POWER CABLE TO CIRCUIT BREAKER BOX. (CONT)

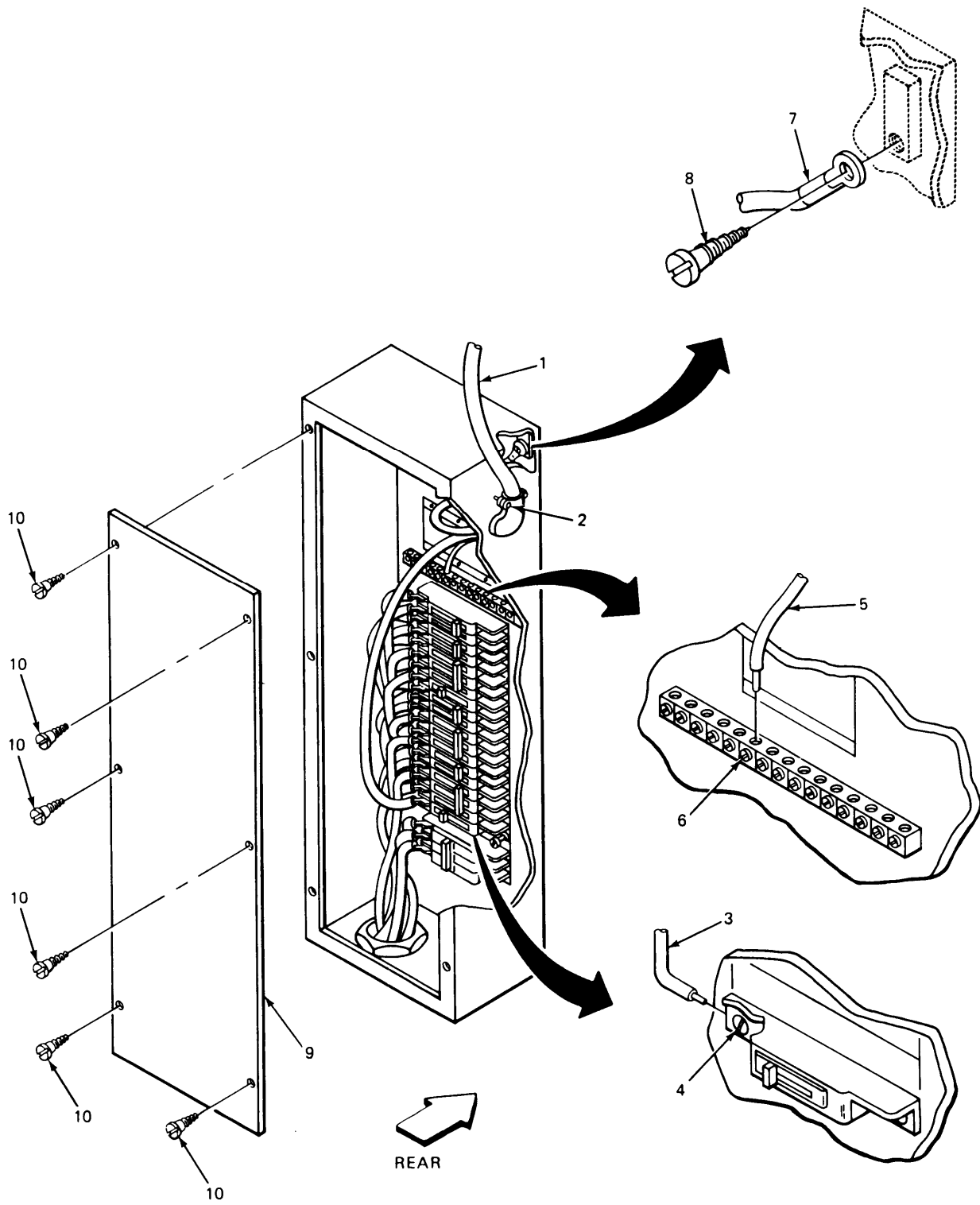

EL8KD056

4-51. ROUTING AND FASTENING POWER CABLE.

This task covers:

Installation

INITIAL SETUP

Tools

Flat-tip screwdriver

Personnel Required

One mechanic

Materials/Parts

Cable clamps (as required)
Flat washer (as required)
Power cable

Equipment Condition

Power to circuit breaker box off. Power cable secured to 90° cable connector.

LOCATION	ITEM	ACTION REMARKS
1. Fourth screw toward forward wall	Screw (1)	Using flat-tip screwdriver, remove. Save.
2.	Screw (1), flat washer (2), cable clamp (3) and power cable (4)	Using flat-tip screwdriver, install. Steps 1 and 2 are typical for every third screw following cable clamp until the forward wall is reached. Pull cable tight after each cable clamp is installed.
3. Along ceiling	Power cable (4)	Do steps 1 and 2 again.
4. Curbside angle bracket connecting ceiling to lower ledge	Power cable (4) and nylon ties (5)	Using nylon ties, install.
5. Curbside, forward overhand ledge	Screw (6)	Remove. Save.

4-51. ROUTING AND FASTENING POWER CABLE. (CONT)

LOCATION	ITEM	ACTION REMARKS
----------	------	-------------------

6.	Screw (6), flat washer (7), cable clamp (8) and power cable (4)	Using flat-tip screwdriver, install. There are three screws. Steps 5 and 6 are typical for all three screws.
----	---	--

7. Curbside	Screws (9)	Do steps 5 and 6 again.
-------------	------------	-------------------------

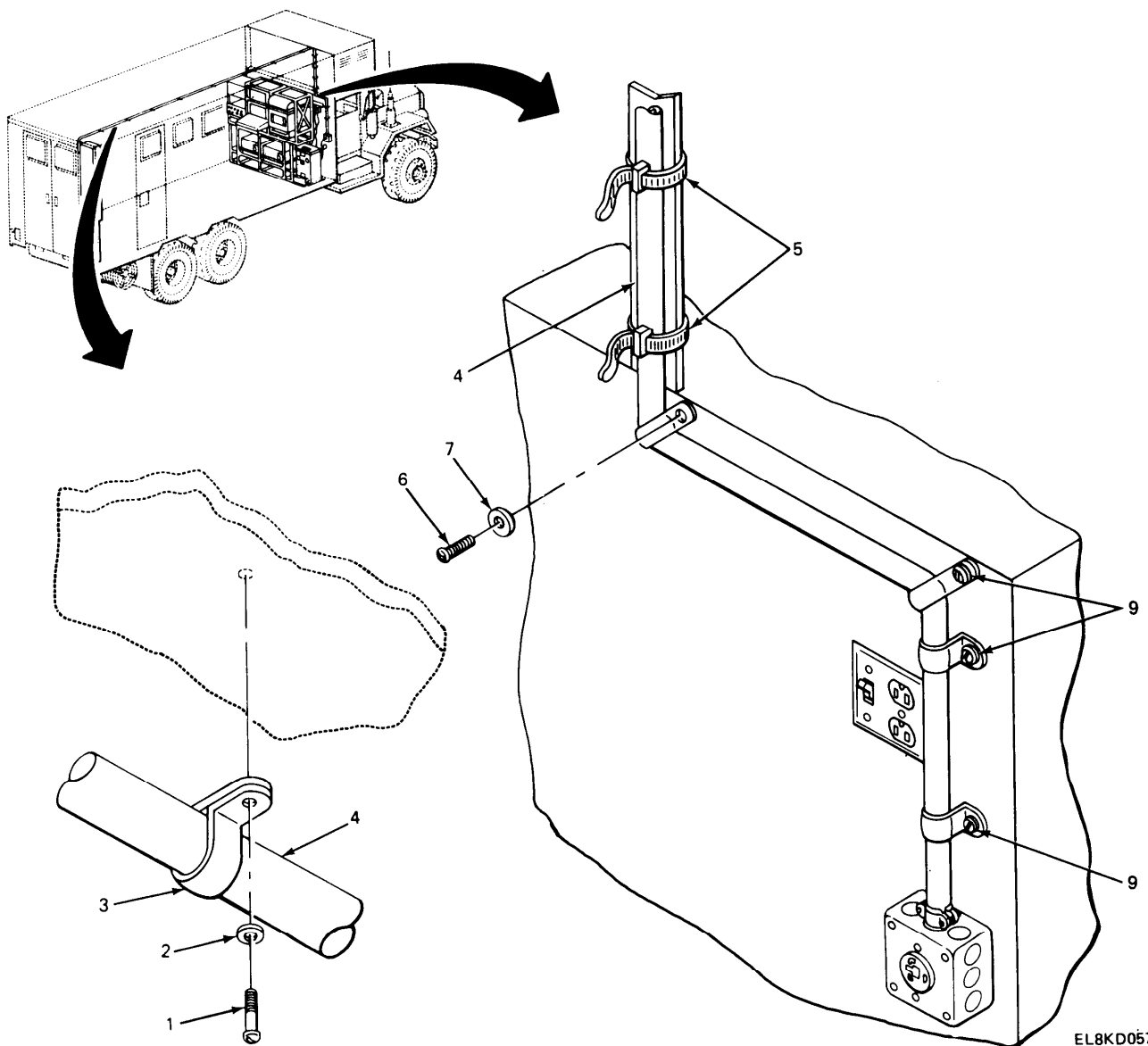

4-52. 4 X 4-INCH OUTLET BOX.

Installation instructions for 4 x 4-inch outlet procedures listed below are given in this section.

- Installing 4 x 4-inch outlet box and cable connector
- Installing power cable and receptacle

4-53. INSTALLING 4 X 4-INCH OUTLET BOX AND CABLE CONNECTOR

This task covers:

Installation

INITIAL SETUP

Tools

- Flat-tip screwdriver
- Pliers

Materials/Parts

- 1-inch sheet metal screws (2 required)
- 4 x 4-inch outlet box
- Conduit locknut
- Cable connector

Personnel Required

One mechanic

Equipment Condition

Power cable installed.

LOCATION	ITEM	ACTION REMARKS
1. Outlet box	Knockout plug (1)	Using flat-tip screwdriver, remove.
2. Curbside, 24 inches down from recess	Outlet box (2) and screws (3)	Using flat-tip screwdriver, install. Hole on top.
3. Knocked out plug hole on outlet box	Cable connector (4) and conduit locknut (5)	Using pliers, install.

4-53. INSTALLING 4 x 4-INCH OUTLET BOX AND CABLE CONNECTOR. (CONT)

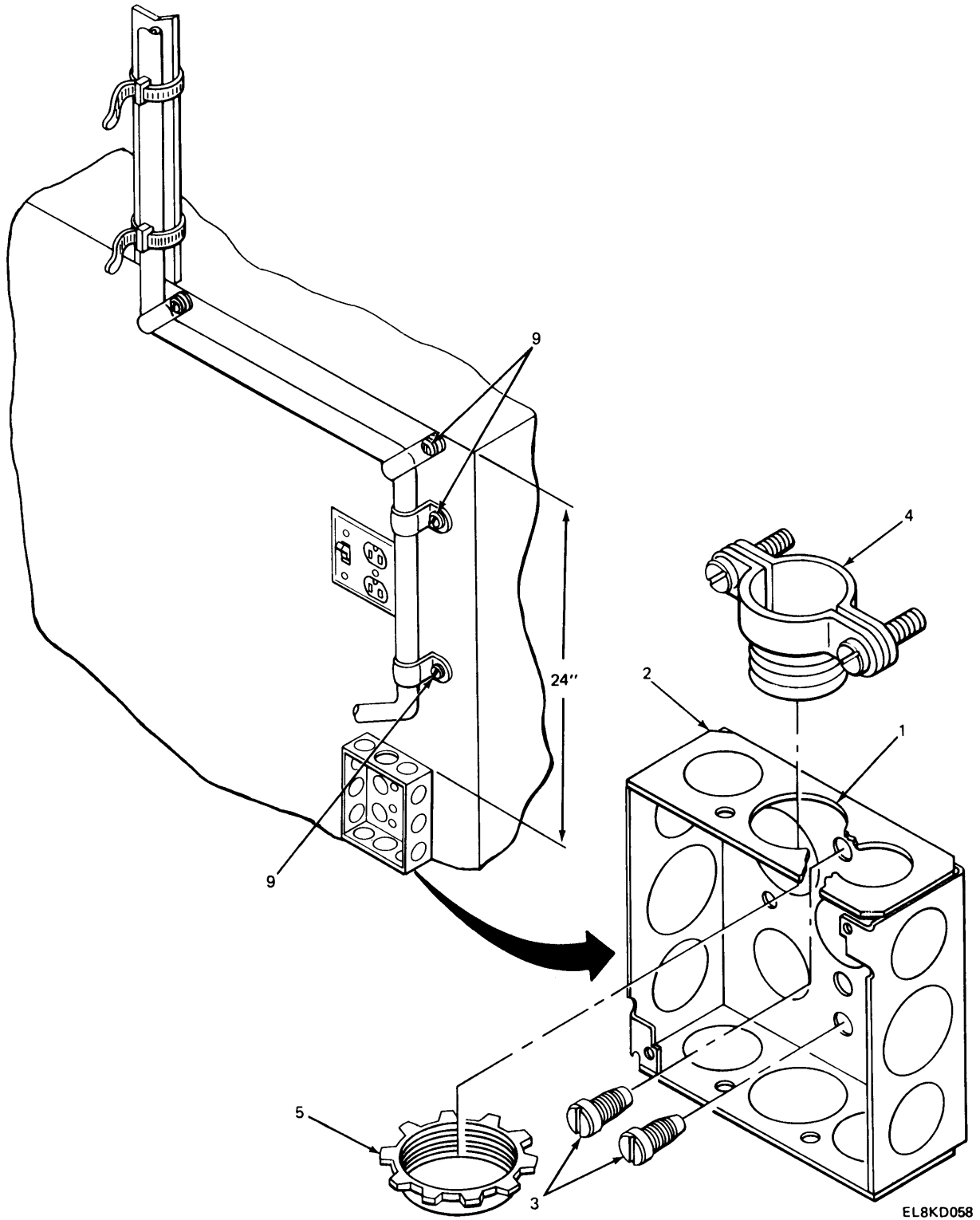

4-54. INSTALLATION OF POWER CABLE AND RECEPTACLE.

This task covers:

Installation

INITIAL SETUP

Tools

- Wire cutters
- Wire strippers
- Ruler
- Flat-tip screwdriver

Personnel Required

One mechanic

Equipment Condition

Outlet box installed.

Materials/Parts

- Receptacle
- Face plate

LOCATION	ITEM	ACTION REMARKS
----------	------	-------------------

NOTE

Put power cable over outlet box. Measure from outlet box down power cable 8 1/2 inches and cut.

1. Outlet box	Power cable (1) and cable clamp (2)	Put power cable into cable clamp.
2. Cable clamp	Screws (3)	Using flat-tip screwdriver, tighten.
3. Power cable	Outer insulation (4)	Using wire strippers, strip 7 inches of outer insulation.
4.	Black wire (5), white wire (6) and green wire (7)	Using wire strippers, strip 5/8 inch insulation from each wire.
5. Face plate	Receptacle (8) and screws (9)	Using flat-tip screwdriver, install.
6. Receptacle	Black wire (5) and terminal X (10)	Using flat-tip screwdriver, install.

4.54. INSTALLING POWER CABLE AND RECEPTACLE. (CONT)

LOCATION	ITEM	ACTION REMARKS
7.	White wire (6) and terminal Y (11)	Using flat-tip screwdriver, install.
8.	Green wire (7) and terminal G (12)	Using flat-tip screwdriver, install.
9.	Face plate (13), outlet box (14) and screws (15)	Using flat-tip screwdriver, install.

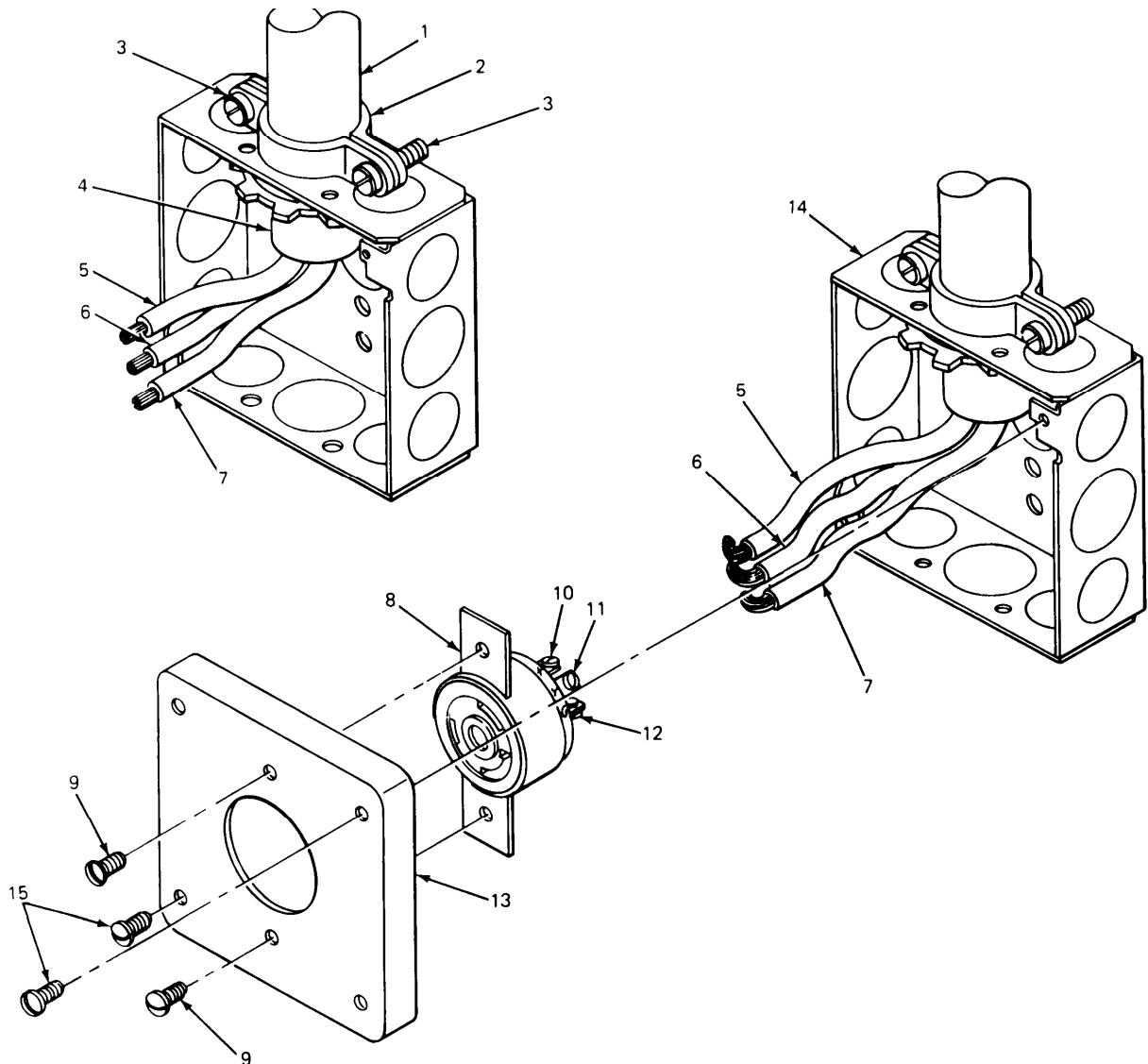

EL8KD059

4-55. POWER SUPPLY.

Instructions for installing power supply are given in this section.

- Preparing power cable for connection to Hubbell connector plug
- Preparing power cable for connection to power supply
- Connecting power cable to power supply
- Installing power supply
- Connecting power supply cable from de/de switch to power supply
- Installing guard assembly

4-56. PREPARING POWER CABLE FOR CONNECTION TO HUBBELL CONNECTOR PLUG.

This task covers:

1. Preparation
2. Installation

INITIAL SETUP

Tools	Personnel Required
Wire cutters Wire strippers Flat-tip screwdriver	One mechanic
Materials/Parts	Equipment Condition
Power cable (5 feet long) Hubbell connector plug	Plug receptacle installed.

LOCATION	ITEM	ACTION REMARKS
----------	------	-------------------

PREPARATION

NOTE

Cut 5-foot power cable to 4 feet in length and save remainder for different voltage hookups in power supply.

1. Power cable	Outer insulation (1)	Using wire strippers, strip 2 inches of outer insulation.
2.	Black wire (2), white wire (3) and green wire (4)	Using wire strippers, strip 5/8 inch of insulation from each wire.
3. Hubbell connector plug	Power cable (5) and screws (6)	Using flat-tip screwdriver, install.

4-56. PREPARING POWER CABLE FOR CONNECTION TO HUBBELL CONNECTOR PLUG. (CONT)

LOCATION	ITEM	ACTION REMARKS
INSTALLATION		
4.	Black wire (2) and screw (7)	Using flat-tip screwdriver, install.
5.	White wire (3) and screw (8)	Using flat-tip screwdriver, install.
6.	Green wire (4) and screw (9)	Using flat-tip screwdriver, install.
7.	Insulator disk (10)	Install.

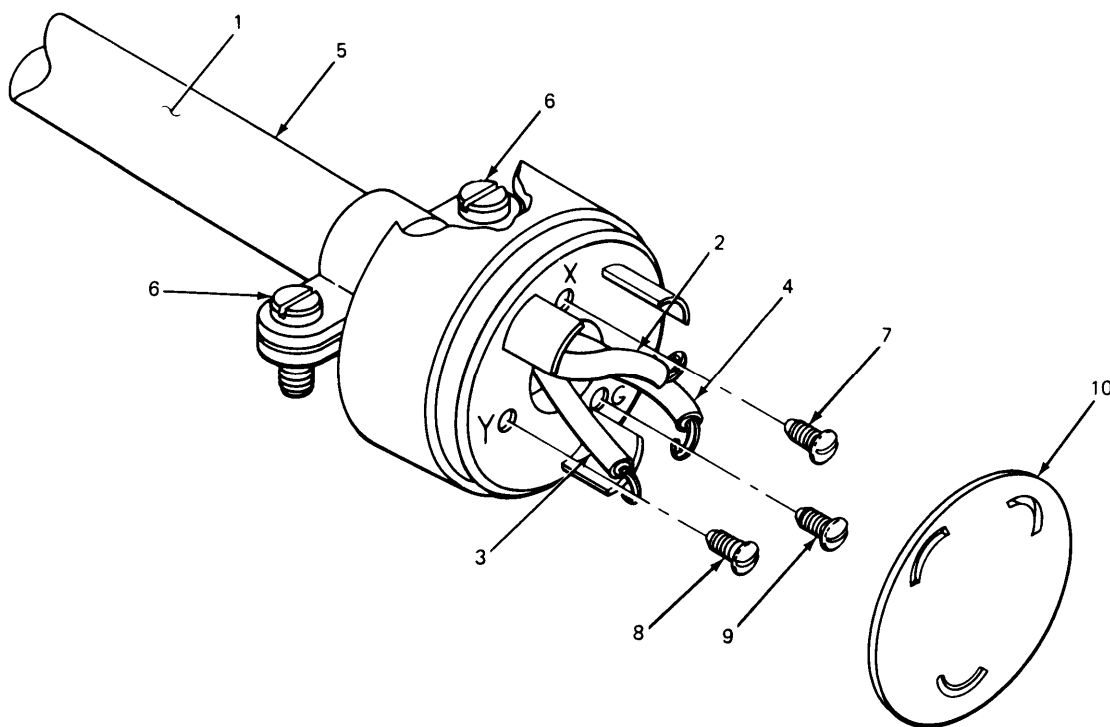

EL8KD060

4-57. PREPARING POWER CABLE FOR CONNECTION TO POWER SUPPLY.

This task covers:

Installation

INITIAL SETUP

Tools

- Pliers
- Wire strippers
- Flat-tip screwdriver

Personnel Required

One mechanic

Equipment Condition

Materials/Parts

- Power supply
- Power cable
- Cable connector
- Conduit locknut

Plug installed on end of 4-foot cable.
Outlet box installed on power supply.

	LOCATION	ITEM	ACTION REMARKS
1.	Opposite Hubbell connector plug on power cable	Outer insulation (1)	Using wire strippers, strip 12 inches of outer insulation.
2.	Power cable	Black wire (2), white wire (3) and green wire (4)	Using wire strippers, strip 5/8 inch of insulation from each wire.
3.		Screws (5) and outlet box cover (6)	Using flat-tip screwdriver, remove.
4.	Top of outlet box	Knockout plug (7)	Using flat-tip screwdriver, remove.
5.	Outlet box	Cable connector (8) and conduit locknut (9)	Using pliers, install.
6.	Cable connector	Power cable (10) and screws (11)	Using flat-tip screwdriver, install.
7.	Inside power supply	Black wire (2) and white wire (3)	Install.

4-57. PREPARING POWER CABLE FOR CONNECTION TO POWER SUPPLY. (CONT)

LOCATION	ITEM	ACTION REMARKS
8. Inside outlet box	Screw (12)	Using flat-tip screwdriver, remove.
9.	Green wire (4) and screw (12)	Using flat-tip screwdriver, install.
10. Rear of outlet box	Outlet box cover (6) and screws (5)	Using flat-tip screwdriver, install.

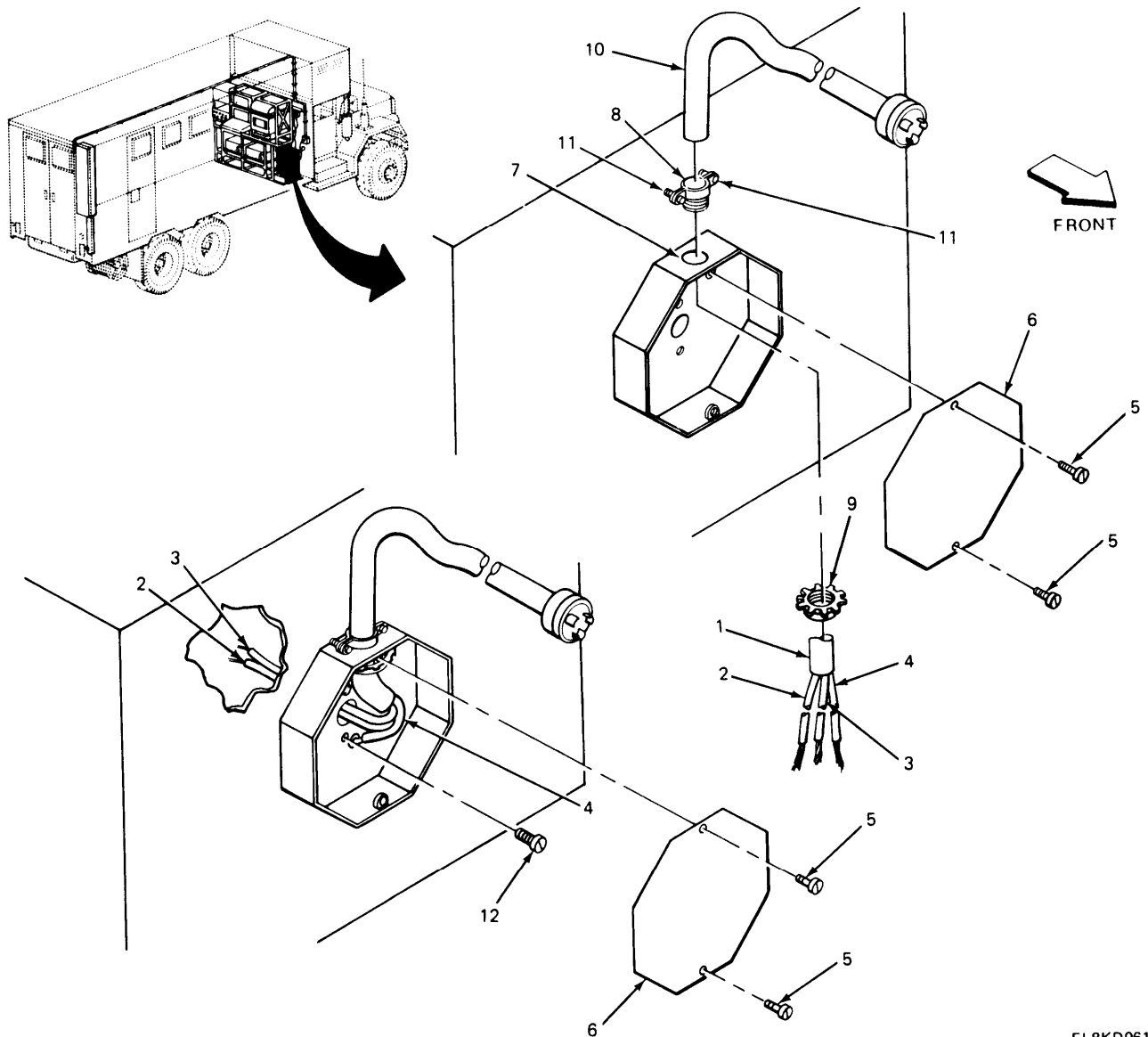

EL8KD061

4-58. CONNECTING POWER CABLE TO POWER SUPPLY.

This task covers:

Installation

INITIAL SETUP

Tools

Wire cutters
Flat-tip screwdriver
Wire strippers

Personnel Required

One mechanic

Equipment Condition

Materials/Parts

Power cable, 1-foot section

Power cable installed in outlet box on rear of power supply.

	LOCATION	ITEM	ACTION REMARKS
1.	Curbside of power supply	Side panel (1)	Remove.
2.	Left-hand connections on power supply terminal board	Black wire (2) and screw (3)	Using flat-tip screwdriver, install.
3.		White wire (4) and screw (5)	Using flat-tip screwdriver, install.
NOTE			
Use 1-foot piece of power cable. Remove outer insulation and use either one or two wires. For 115 volt hook up, use two wires.			
4.	Any two wires from 1-foot power cable	Wire (6) and wire (7)	Using wire strippers, strip 5/8 inch of insulation from each wire. If needed, cut wires to desired length for installation.
5.	Right side of terminal board	Wire (6), screws (8), wire (7) and screws (9)	Using flat-tip screwdriver, install.

4-58. CONNECTING POWER CABLE TO POWER SUPPLY. (CONT)

LOCATION	ITEM	ACTION REMARKS
----------	------	-------------------

NOTE

For 230-volt hookup, use one wire.

- | | | |
|----|---------------------------|--------------------------------------|
| 6. | Wire (10) and screws (11) | Using fiat-tip screwdriver, install. |
|----|---------------------------|--------------------------------------|

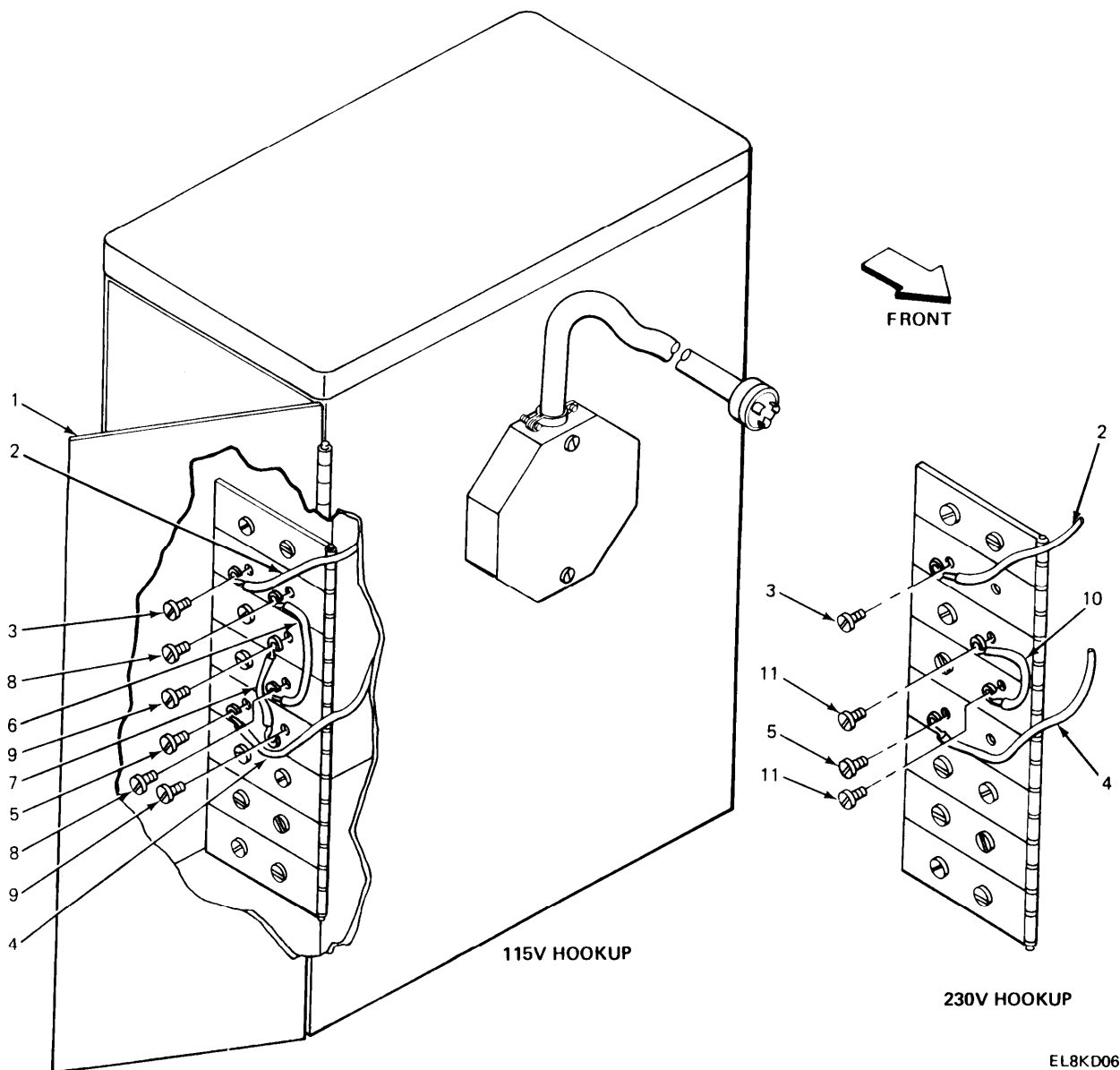

EL8KD062

4-59. INSTALLING PP-1104 POWER SUPPLY.

This task covers:

Installation

INITIAL SETUP

Tools

1/2-inch box wrench

Personnel Required

One mechanic

Materials/Parts

5/16-18 x 1 inch long hex head screw
(6 required)
5/16-inch lockwasher (6 required)
5/16-inch flat washer (6 required)
Power supply

Equipment Condition

Angle brackets installed on power supply.

	LOCATION	ITEM	ACTION REMARKS
1.	Curbside, near forward wall	Power supply (1)	Put power supply over mounting holes, aline.
2.	Front angle bracket of power supply	Screw (2), lockwasher (3) and flat washer (4)	Install, handtighten. There are three screws. Step 2 is typical for all three screws.
3.		Screw holes (5)	Do step 2 again.
4.	Rear of power supply	Rear angle bracket (6)	Do steps 2 and 3 again for rear angle bracket.
5.	Front of power supply	Screw (2)	Using 1/2-inch box wrench, tighten. There are three screws. Step 5 is typical for all three screws.
6.		Screws (2)	Do step 5 again.
7.	Rear of power supply	Rear angle bracket (6)	Do steps 5 and 6 again for rear angle bracket.
8.		Hubbell connector (7) and 4 x 4-inch outlet box (8)	Plug connector into 4 x 4-inch outlet box.

4-59. INSTALLING PP-1104 POWER SUPPLY. (CONT)

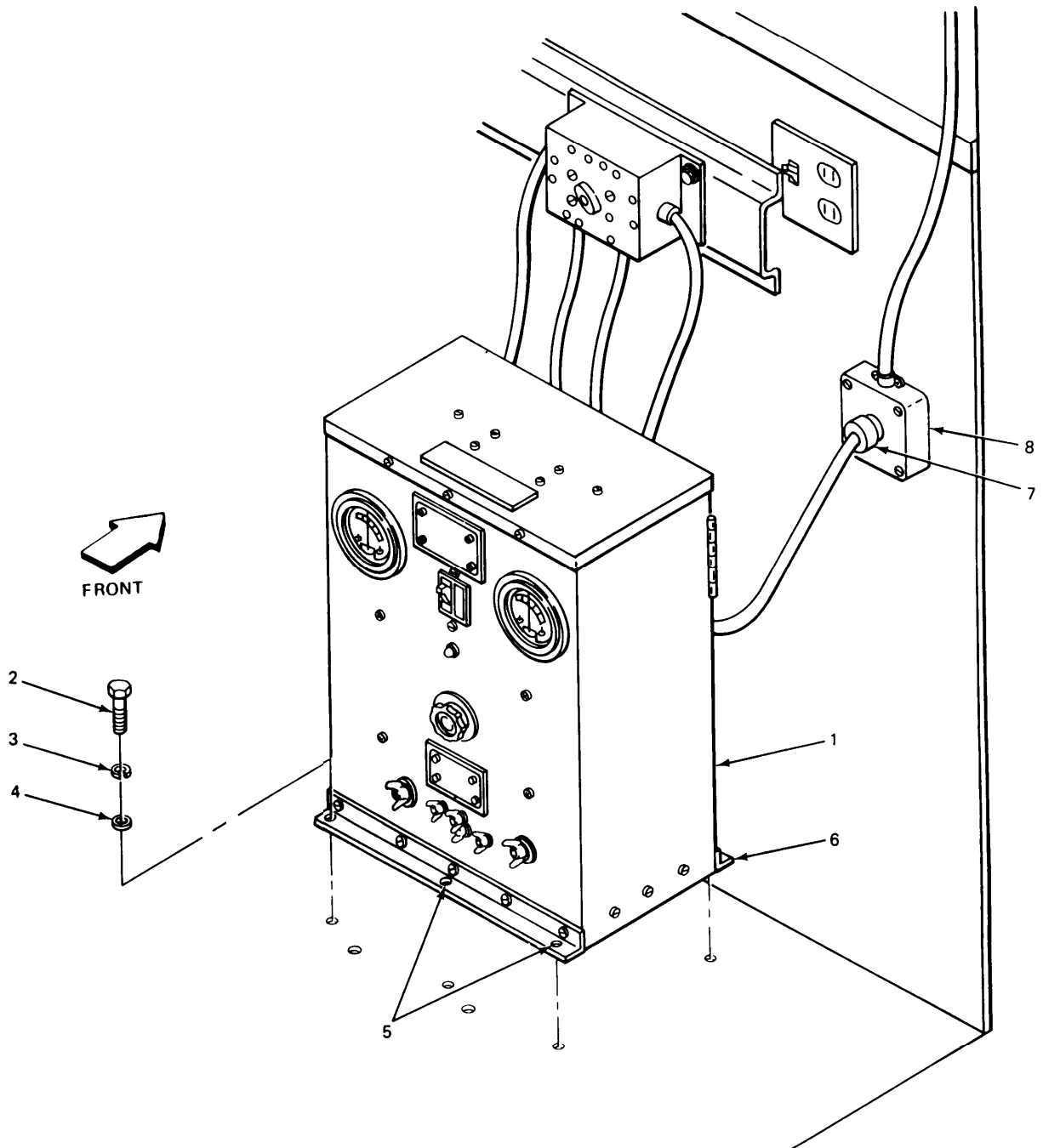

EL8KD063

4-60. INSTALLING PP-4763 POWER SUPPLY.

This task covers:

Installation

INITIAL SETUP

Tools

1/2-inch box wrench

Personnel Required

Two mechanics

Materials/parts

5/16-18 x 1 inch long hex head screw
(6 required)
5/16-inch lockwasher (6 required)
5/16-inch flat washer (6 required)
Power supply

Equipment Condition

Angle brackets installed on
power supply.

LOCATION	ITEM	ACTION REMARKS
----------	------	-------------------

NOTE

A helper will be needed to lift and position power supply.

1. Curbside rear forward wall	Power supply (1)	Put power supply over mounting holes, aline.
2. Curbside angle bracket	Screw (2), lockwasher (3) and flat washer (4)	Install, handtighten. There are three screws. Step 2 is typical for all three screws.
3.	Screw holes (5)	Do step 2 again.
4. Roadside of power supply	Roadside angle bracket (6)	Do steps 2 and 3 again.
5. Curbside and roadside angle brackets	Screws (2)	Using 1/2-inch box wrench, tighten. There are six screws. Step 5 is typical for all six screws.

4-60. INSTALLING PP-4763 POWER SUPPLY. (CONT)

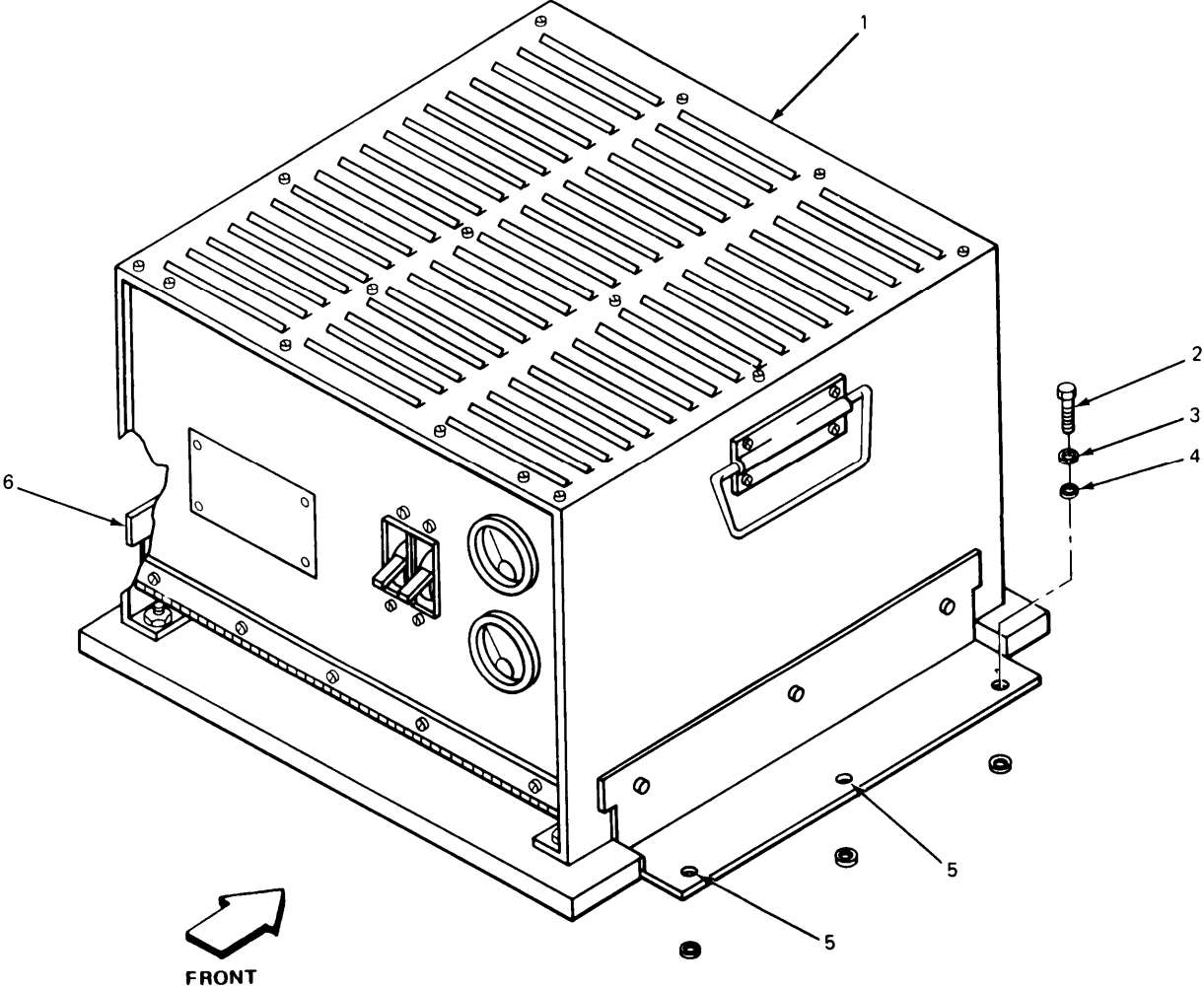

EL8KD064

4-61. CONNECTING POWER SUPPLY CABLE FROM DC/DC SWITCH TO POWER SUPPLY.

This task covers:

Installation

INITIAL SETUP

Tools

1/2-inch box wrench
Pliers

Personnel Required

One mechanic

Materials/parts

None

Equipment Condition

DC/DC switch power cable routed to front of power supply.

LOCATION	ITEM	ACTION REMARKS
----------	------	-------------------

WARNING

Observe polarity when connecting leads.

1. Left connection on front of power supply	Negative wire (1), 10-inch ground strap (2) and wingnut (3)	Using pliers, install. Negative wire installed on negative terminal.
2. Right connection on front of power supply	Positive wire (4) and wingnut (5)	Using pliers, install. Positive wire installed on positive terminal.
3. Front angle bracket	Screw (6), lock-washer (7) and flat washer (8)	Using 1/2-inch box wrench, remove.
4.	Screw (6), lock-washer (7), flat washer (8) and 10-inch ground strap (2)	Using 1/2-inch box wrench, install.

4-61. CONNECTING POWER SUPPLY CABLE FROM DC/DC SWITCH TO POWER SUPPLY. (CONT)

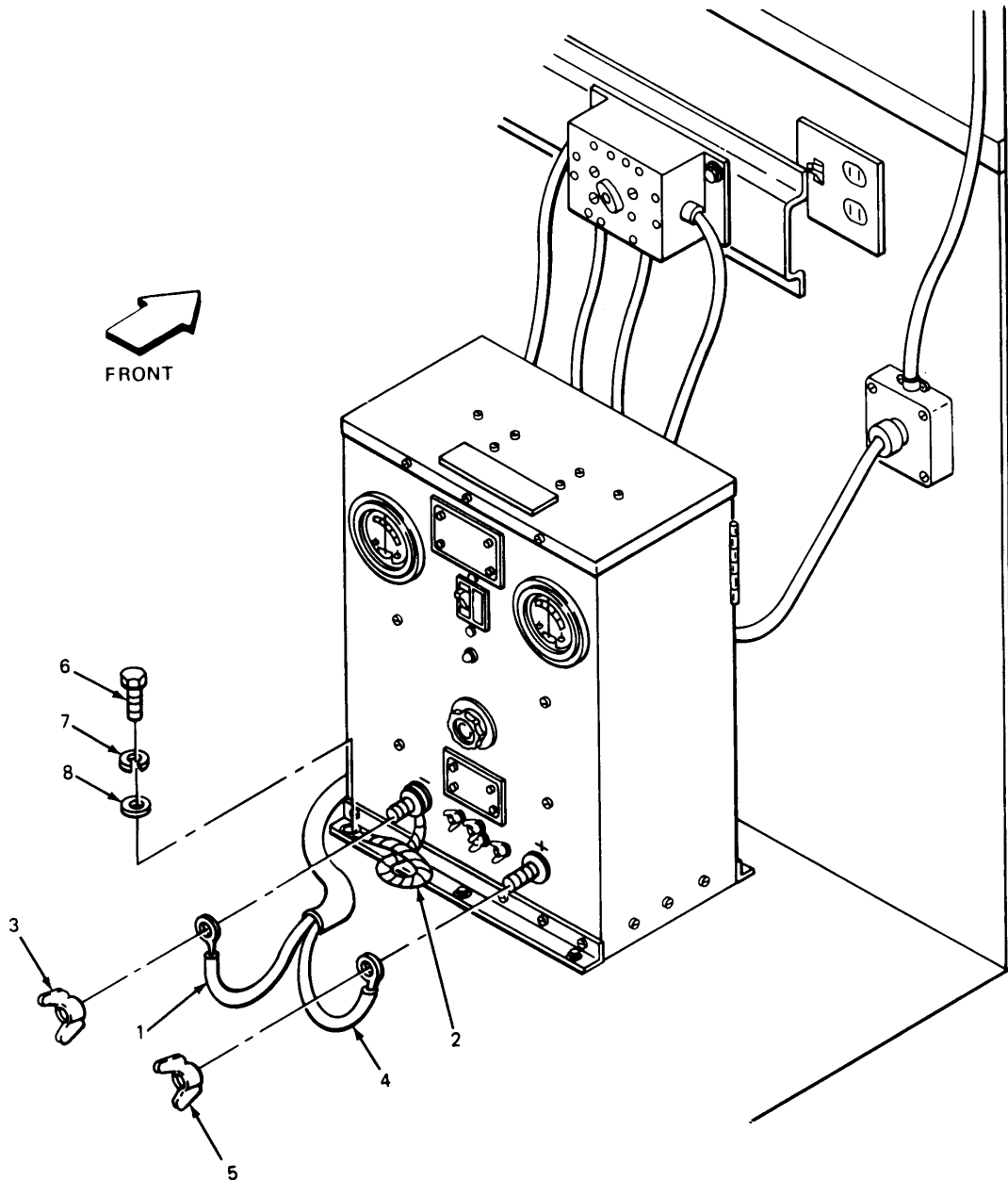

EL8KD065

4-62. INSTALLING PP-1104 POWER SUPPLY GUARD ASSEMBLY.

This task covers:

Installation

INITIAL SETUP

Tools

1/2-inch box wrench

Personnel Required

One mechanic

Materials/Parts

5/16-18 x 1 inch long hex head screw
(2 required)
5/16-inch flat washer (2 required)
5/16-inch lockwasher (2 required)

Equipment Condition

DC/DC switch power cable connected.

LOCATION	ITEM	ACTION REMARKS
1. In front of power supply	Guard assembly (1)	Put guard assembly in place and aline holes.
2. Guard assembly mounting hole	Screw (2), lock-washer (3) and flat washer (4)	Using 1/2-inch box wrench, install.
3.	Screw (5), lock-washer (6) and flat washer (7)	Using 1/2-inch box wrench, install.

4-62. INSTALLING PP-1104 POWER SUPPLY GUARD ASSEMBLY. (CONT)

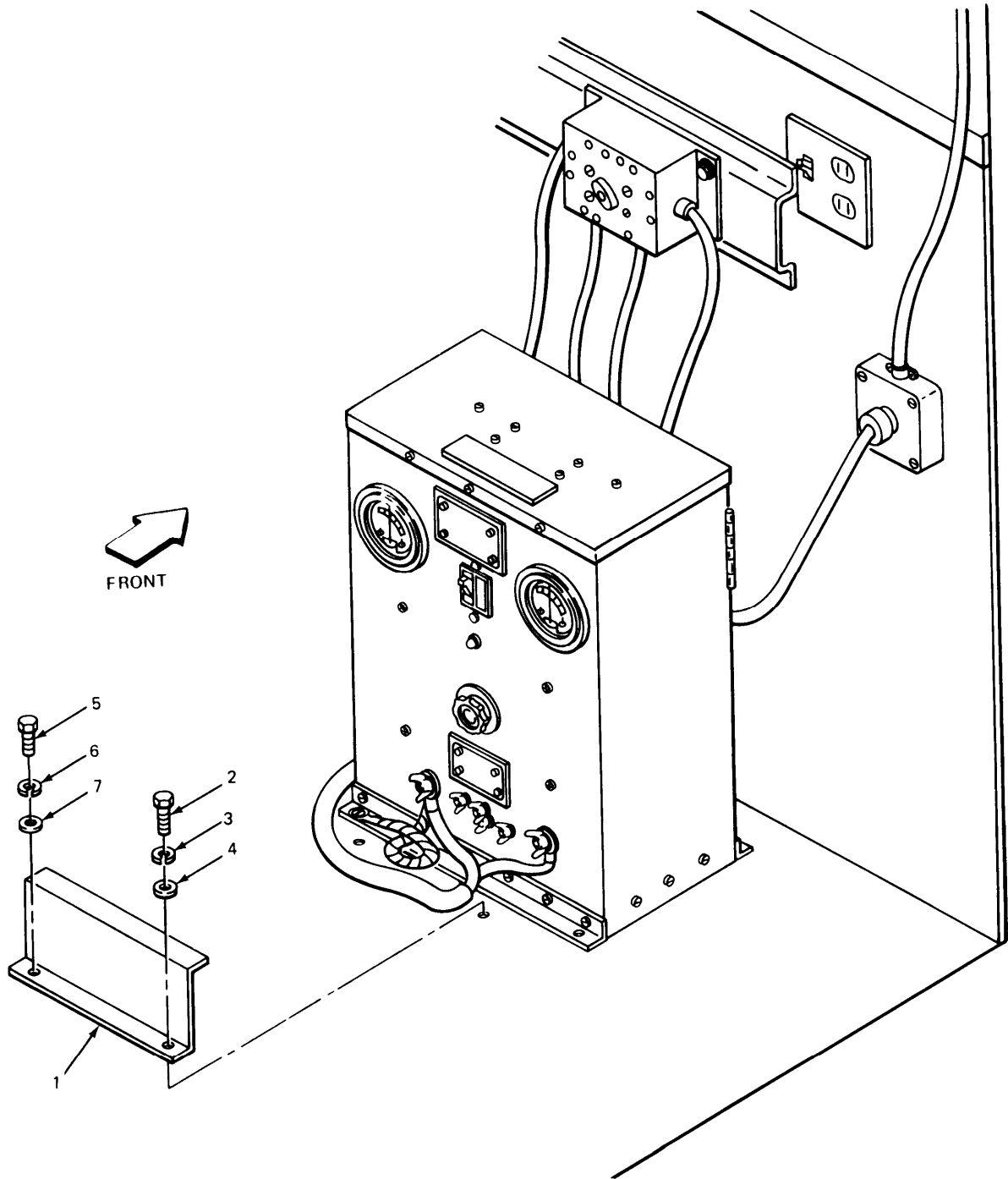

EL8KD066

4-63. INSTALLING EXTERNAL GROUND ROD KIT.

This task covers:

Installation

INITIAL SETUP

<p>Tools</p> <p>8-lb sledge hammer Flat-tip screwdriver Pliers</p> <p>Materials/Parts</p> <p>Ground rod clamp Ground strap assembly (10 ft) Ground rod, sectional (9 ft)</p>	<p>Personnel Required</p> <p>One mechanic</p> <p>Equipment Condition</p> <p>Vehicle not moving.</p>
--	---

LOCATION	ITEM	ACTION REMARKS
----------	------	-------------------

NOTE

The external ground rod is used only when vehicle is not moving. It is stored under radio mount.

1. Roadside lower gusset	Wingnut (1) and IT lockwasher (2)	Using pliers, remove.
2.	10-foot ground strap (3), IT lockwasher (2) and wingnut (1)	Install.

NOTE

The ground rod comes in three sections. Using driving stud and sledge hammer, drive one section into ground at a time. After a section is driven into ground, couple next section to it.

3. Ground rod clamp	10-foot ground strap (3) and ground rod strap screw (4)	Using flat-tip screwdriver, install.
---------------------	---	--------------------------------------

4-63. INSTALLING EXTERNAL GROUND ROD KIT. (CONT)

LOCATION	ITEM	ACTION REMARKS
----------	------	-------------------

4. Ground rod	Ground rod clamp (5) and screws (6)	Using flat-tip screwdriver, install.
---------------	--	--------------------------------------

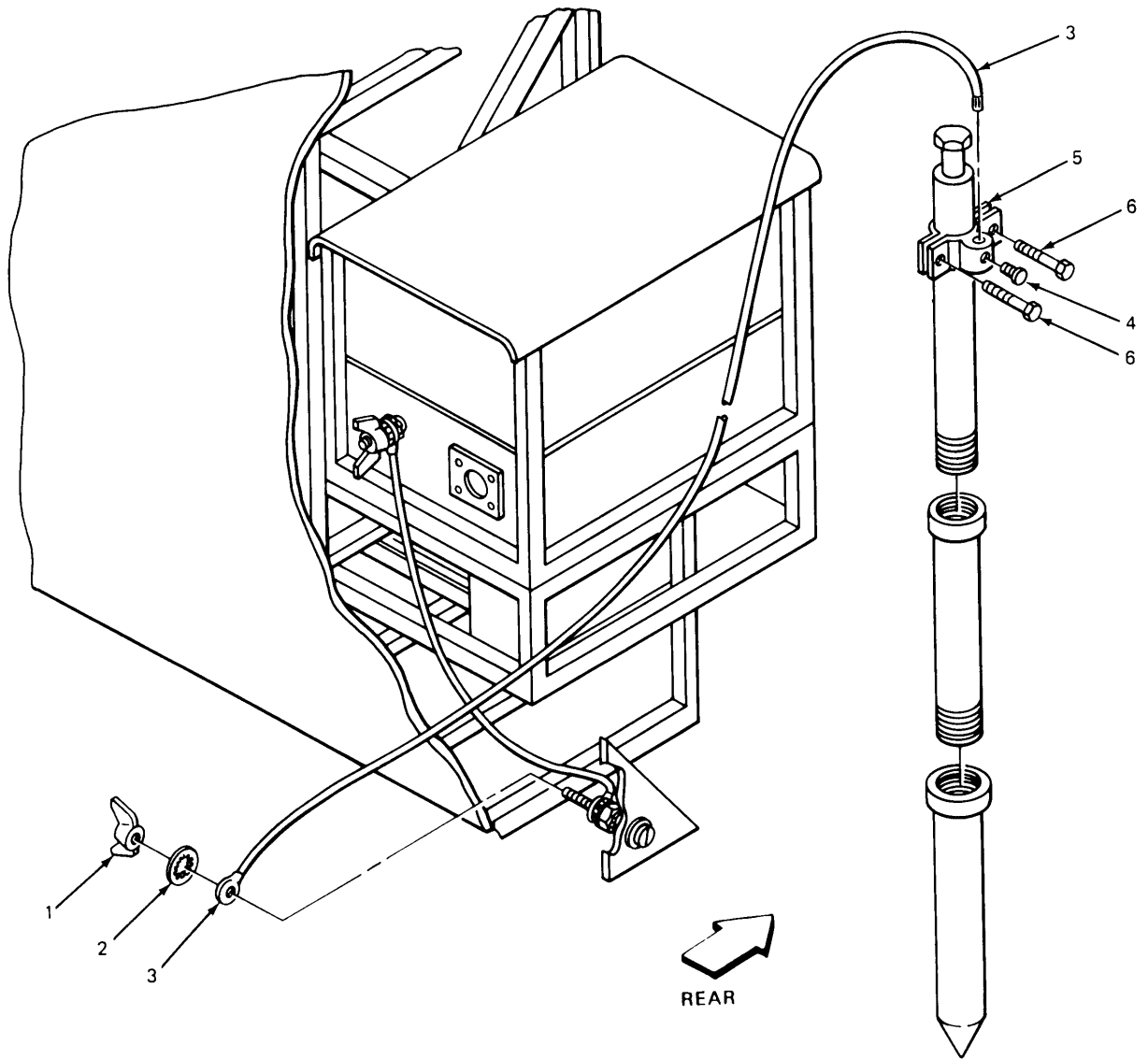

EL8KD067

Section IV PREVENTIVE MAINTENANCE CHECKS AND SERVICES (PMCS)

There are no special organizational preventive maintenance checks and services for this equipment. Routine checks like equipment inventory, broken cables, replacing damaged items, tightening loose hardware, are not listed in (PMCS) table. You should do these checks and services daily.

Section V TROUBLESHOOTING PROCEDURES

No troubleshooting procedures for the Electronics Equipment Installation Kit MK-1818/GSG-10(V) are given in this manual. For organizational troubleshooting procedures for the electronic equipment refer to manuals TM 11-7440-253-10-1 and TM 11-7440-251-10.

Section VI MAINTENANCE PROCEDURES

For maintenance procedures for electronic equipment used with these installation kits refer to manuals TM 11-7440-251-10 and TM 7440-253-10-1.

Section VII REMOVAL OF ELECTRONIC EQUIPMENT INSTALLATION KIT MK-1818/GSG-10(V)

Subject	Para	Page
Removing PP-1104 Power Supply Guard Assembly	4-64	4-122
Removing/Installing Angle Brackets on PP-1104 Power Supply	4-65	4-124
Removing Angle Brackets from PP-4763 Power Supply	4-66	4-128
Removing/Installing PP-1104 Power Supply	4-67	4-130
Removing/Installing PP-4763 Power Supply	4-68	4-134
Removing/Installing Hubbell Connector Plug	4-69	4-136
Removing/Installing Power Cable on Power Supply	4-70	4-138
Removing/Installing Receptacle	4-71	4-140
Removing/Installing 4 x 4-Inch Outlet Box	4-72	4-142
Removing 26-Foot Power Cable	4-73	4-144
Removing/Installing Circuit Breaker	4-74	4-148
Removing/Installing 90° Cable Connector	4-75	4-150
Removing Pipe Nipple	4-76	4-154
Removing/Installing DC/DC Switch	4-77	4-156
Removing Tacfire Components	4-78	4-158
Removing 30-inch Ground Strap	4-79	4-160
Removing 4-Inch Ground Straps	4-80	4-162
Removing/Installing Electronic Line Printer Rack	4-81	4-164
Removing/Installing Message Entry Group Rack	4-82	4-168
Removing/Installing Key Generator Rack	4-83	4-172
Removing/Installing Electronic Equipment Table	4-84	4-176
Removing/Installing Radio Mount	4-85	4-180
Removing Radio Mounting Bases MT-1029/VRC	4-86	4-182
Removing/Installing Wall Support	4-87	4-184
Removing Curbside or Roadside Antenna Cables	4-88	4-186
Removing Antenna Masts	4-89	4-188
Removing Curbside or Roadside Antenna Mount Assemblies	4-90	4-190
Removing External Grounding Rod	4-91	4-192

4-64. REMOVING PP-1104 POWER SUPPLY GUARD ASSEMBLY.

This task covers:

Removal

INITIAL SETUP

Tools

1/2-inch box wrench

Personnel Required

One mechanic

Materials/Parts

None

Equipment Condition

Power in vehicle off.

LOCATION	ITEM	ACTION REMARKS
<u>WARNING</u>		
All power in vehicle off. Remove plug from 4 x 4-inch outlet box.		
1. Curbside, in front of power supply	Screw (1), lock-washer (2) and flat washer (3)	Using 1/2-inch box wrench, remove.
2.	Screw (4), lock-washer (5) and fiat washer (6)	Using 1/2-inch box wrench, remove.
3.	Guard assembly (7)	Remove. For storage, place hardware in cloth bag, attach to guard assembly and pack in original carton.
4.	Guard assembly (7)	See paragraph 4-62 for installation.

4-64. REMOVING PP-1104 POWER SUPPLY GUARD ASSEMBLY. (CONT)

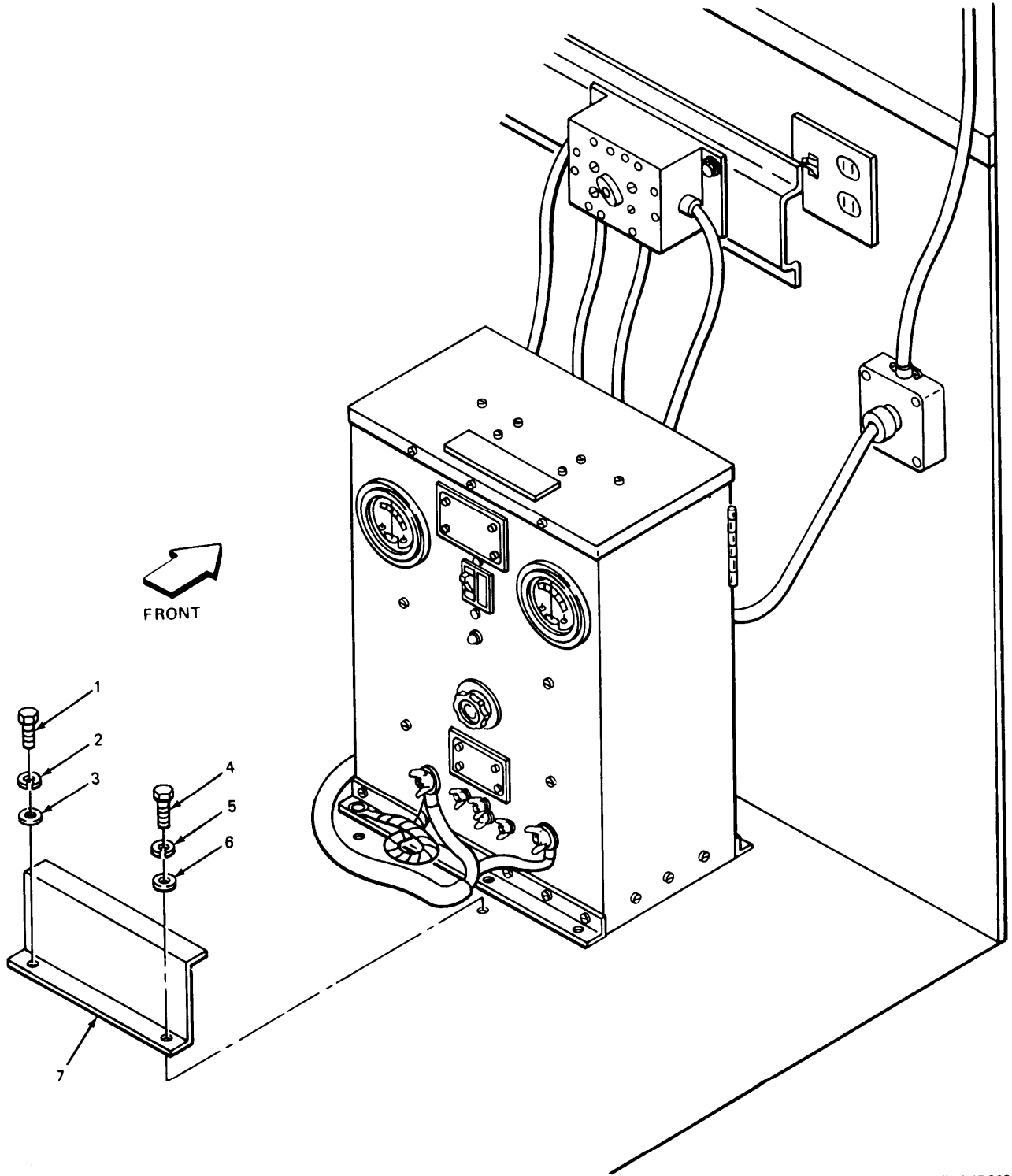

EL8KD068

4-65. REMOVING/INSTALLING ANGLE BRACKETS ON PP-1104 POWER SUPPLY.

This task covers:

1. Removal
2. Installation

INITIAL SETUP

Tools	Personnel Required
Pliers 1/2-inch box wrench Flat-tip screwdriver	One mechanic
Materials/Parts	Equipment Condition
None	All power in vehicle off. Guard assembly removed. (See paragraph 4-64.)

LOCATION	ITEM	ACTION REMARKS
----------	------	-------------------

REMOVAL

1. Front of power	Wingnuts (1)	Using pliers, remove.
2.	DC/DC switch power cable (2)	Remove. Remove both wires. Do not remove 10-inch electrical lead unless replacement is required.
3. Front angle bracket	Screw (3), lock-washer (4) and flat washer (5)	Using 1/2-inch box wrench, remove. There are three screws per angle bracket. Step 5 is typical for all three screws.
4.	Screws (6)	Do step 5 again.
5. Rear of power supply	Rear angle bracket (7)	Do steps 5 and 6 for rear angle bracket.
6. Curbside, near forward wall	Power supply (8)	Remove.

4-65. REMOVING/INSTALLING ANGLE BRACKETS ON PP-1104 POWER SUPPLY. (CONT)

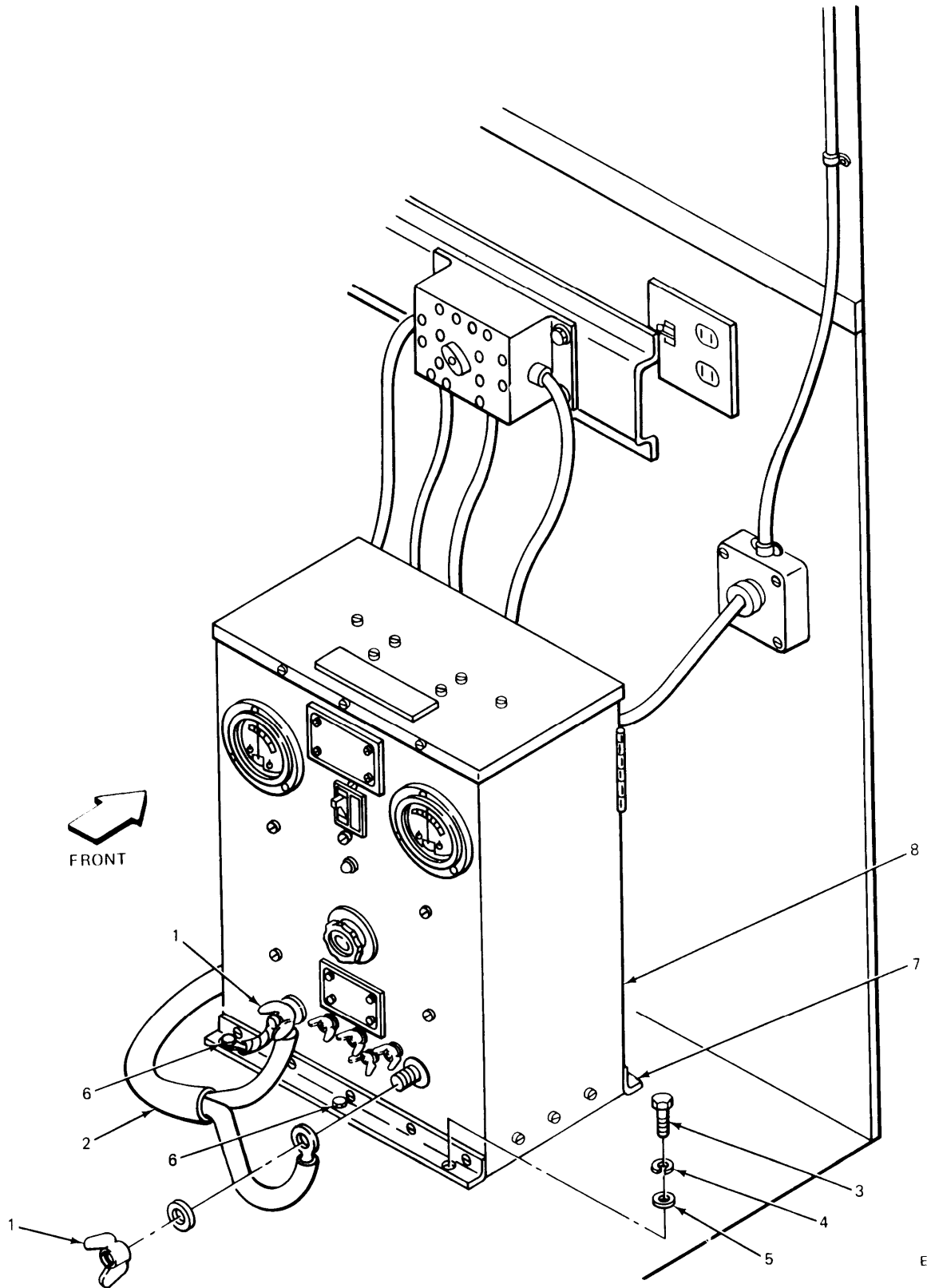

EL8KD072

4.65. REMOVING/INSTALLING ANGLE BRACKETS ON PP-1104 POWER SUPPLY. (CONT)

LOCATION	ITEM	ACTION REMARKS
REMOVAL (CONT)		
7. Front angle bracket	Screw (1), lock-washer (2) and flat washer (3)	Using flat-tip screwdriver, remove., There are five screws per angle bracket. Step 7 is typical for all five screws.
8.	Screws (4)	Do step 7 again.
9.	Front angle bracket (5)	Remove.
10. Rear of power supply	Rear angle bracket (6)	Do steps 9, 10 and 11 again for rear angle bracket. For storage, put hardware in cloth bag, attach to angle brackets and pack in original carton.

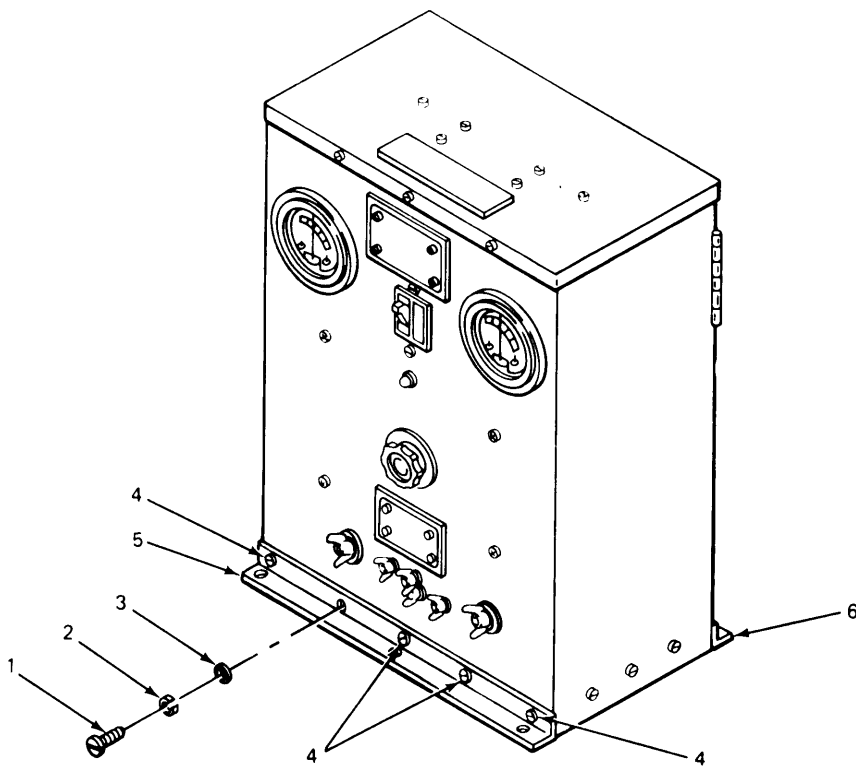

EL8KD073

4-65. REMOVING/INSTALLING ANGLE BRACKETS ON PP-1104 POWER SUPPLY. (CONT)

LOCATION	ITEM	ACTION REMARKS
INSTALLATION		
1. Power supply	Front angle bracket (1) and rear angle bracket (2)	See paragraph 4-12 for installation.
2. Curbside, near forward wall	Power supply (3)	See paragraph 4-59 for installation.
3. Front of power supply	DC/DC switch power cable (4) and wingnuts (5)	Using pliers, install. Positive wire connects to positive terminal. Negative wire connects to negative terminal.
4.	Guard assembly (6)	Put guard assembly in place and aline holes.
5. Guard assembly	Screw (7), lock-washer (8) and flat washer (9)	Using 1/2-inch box wrench, install.
6.	Screw (10), lock-washer (11) and flat washer (12)	Using 1/2-inch box wrench, install.

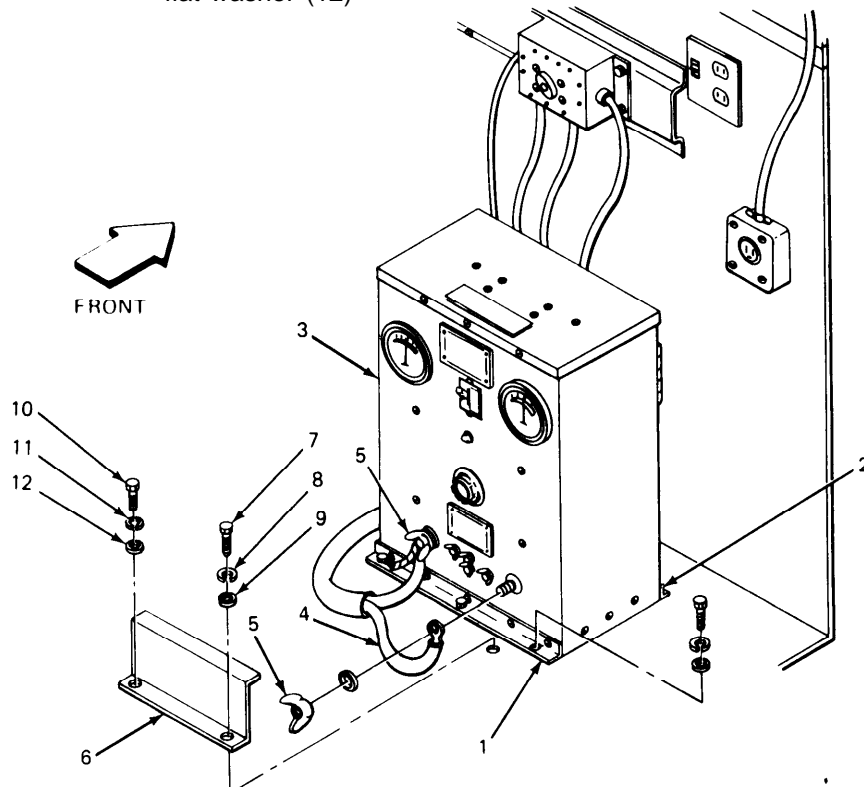

4-66. REMOVING ANGLE BRACKETS FROM PP-4763 POWER SUPPLY.

This task covers:

Removal

INITIAL SETUP

Tools

7/16-inch box end wrench

Personnel Required

One mechanic

Materials/Parts

None

Equipment Condition

Power supply removed from floor. (See paragraph 4-60.)

LOCATION	ITEM	ACTION REMARKS
1. Left side of power supply	Screw (1) and lockwasher (2)	Using two 7/16-inch box wrenches, remove. There are three screws. Step 1 is typical for all three screws.
2.	Screws (3)	Do step 1 again.
3.	Angle bracket (4)	Remove.
4. Right side of power supply	Angle bracket (5)	Do steps 1, 2 and 3 again. See paragraph 4-13 for installation.

4-66. REMOVING ANGLE BRACKETS FROM PP-4763 POWER SUPPLY. (CONT)

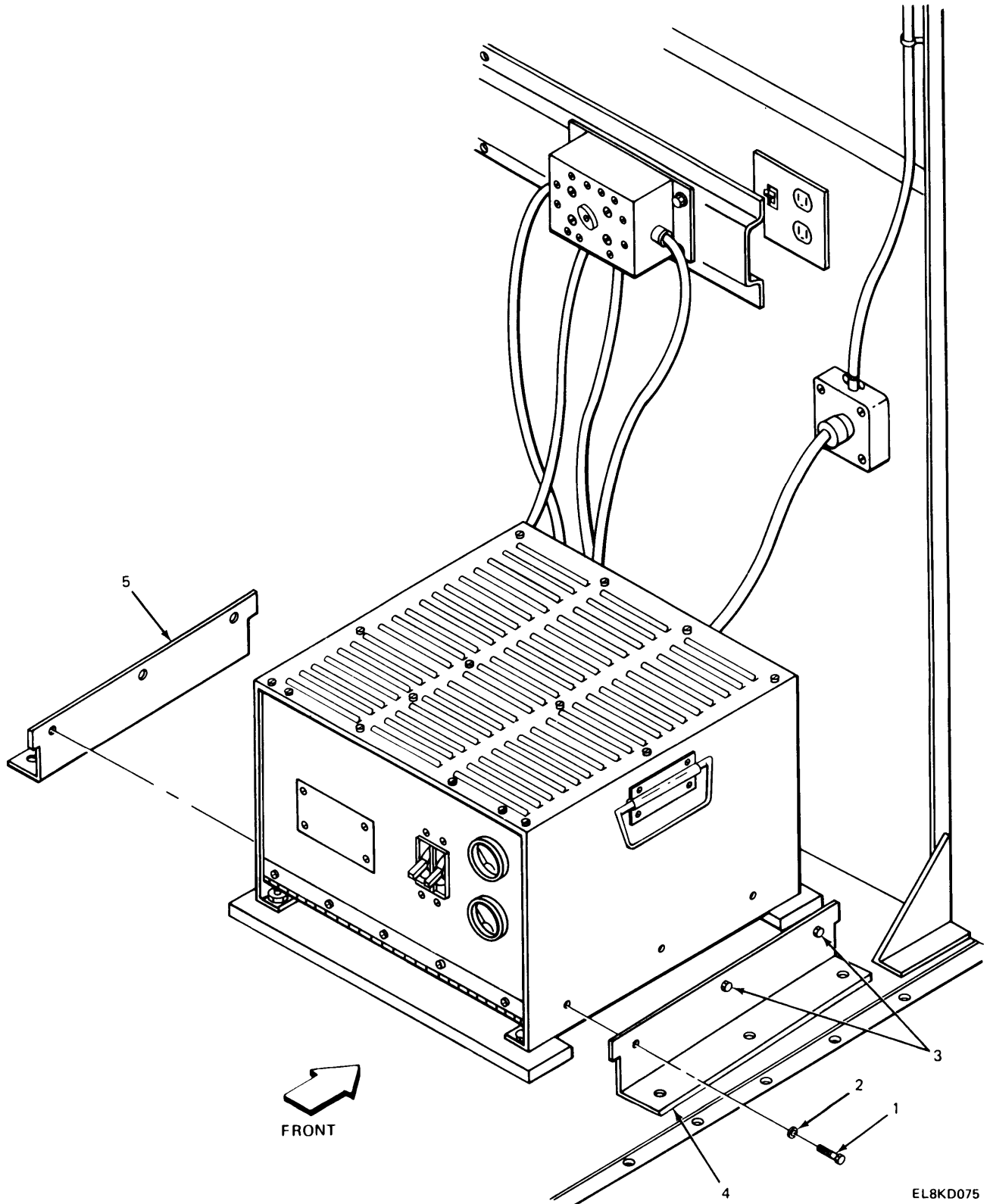

4-67. REMOVING/INSTALLING PP-1104 POWER SUPPLY.

This task covers:

1. Removal
2. Installation

INITIAL SETUP

<p>Tools</p> <p>Pliers Flat-tip screwdriver</p> <p>Materials/Parts</p> <p>Power supply</p>	<p>Personnel Required</p> <p>One mechanic</p> <p>Equipment Condition</p> <p>Guard assembly removed. (See paragraph 4-64.) Angle brackets and power supply removed. (See paragraph 4-65.)</p>
--	--

LOCATION	ITEM	ACTION REMARKS
----------	------	-------------------

REMOVAL

1. Rear of power supply	Screws (1) and outlet box cover (2)	Using flat-tip screwdriver, remove.
2. Right side of power supply	Cover (3)	Using flat-tip screwdriver, remove.
3. Terminal board	Screws (4) and screws (5)	Using flat-tip screwdriver, loosen.
4.	Black wire (6), white wire (7) and jumper leads (8)	Remove. Remove wires from connections. Save jumper leads.
5. Inside outlet box on rear of power supply	Screw (9)	Using flat-tip screwdriver, loosen.
6.	Green wire (10)	Remove.
7.	Conduit lock-nut (11)	Using pliers, remove.

4-67. REMOVING/INSTALLING PP-1104 POWER SUPPLY. (CONT)

LOCATION	ITEM	ACTION REMARKS
----------	------	-------------------

REMOVAL (CONT)

8. Outlet box

Power cable (12)

Remove.

Remove power cable with cable connector.

9. Front, negative terminal

10-inch electrical lead (13)

Remove.

For storage, put hardware in cloth bag, attach to power supply and pack in original carton.

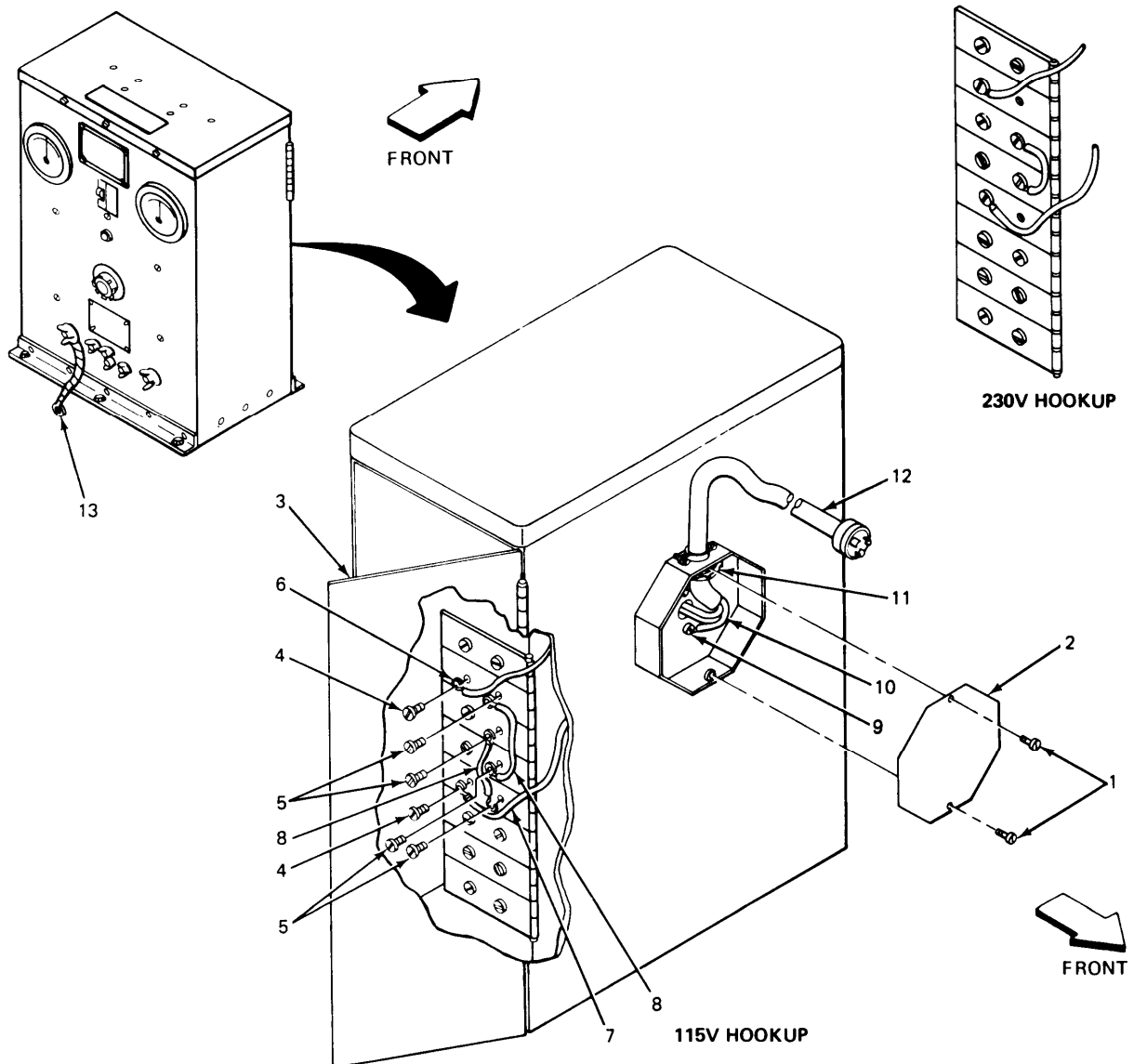

EL8KD069

4-67. REMOVING/INSTALLING PP-1104 POWER SUPPLY. (CONT)

LOCATION	ITEM	ACTION REMARKS
INSTALLATION		
1. Rear of power supply	Screws (1) and outlet box cover (2)	Using flat-tip screwdriver, remove.
2. Top of outlet box on rear of power supply	Knockout plug (3)	Using flat-tip screwdriver, remove.
3. Knocked out plug	Power cable with cable connector (4) and conduit locknut (5)	Using pliers, install.
4. Inside power supply	Black wire (6) and white wire (7)	Install. Put inside power supply.
5. Inside outlet box	Green wire (8) and screw (9)	Using flat-tip screwdriver, install.
6. Outlet box	Outlet box cover (2) and screws (1)	Using flat-tip screwdriver, install.

NOTE

See paragraph 4-58 for power cable connections.

7. Front and rear of power supply	Angle brackets	See paragraph 4-12 for installation.
8. Curbside, near forward wall	Power supply	See paragraph 4-59 for installation.
9. Front of power supply	DC/DC switch power cable	See paragraph 4-35 for installation.
10. Front of power supply	Guard assembly	See paragraph 4-62 for installation.

4-67. REMOVING/INSTALLING PP-1104 POWER SUPPLY. (CONT)

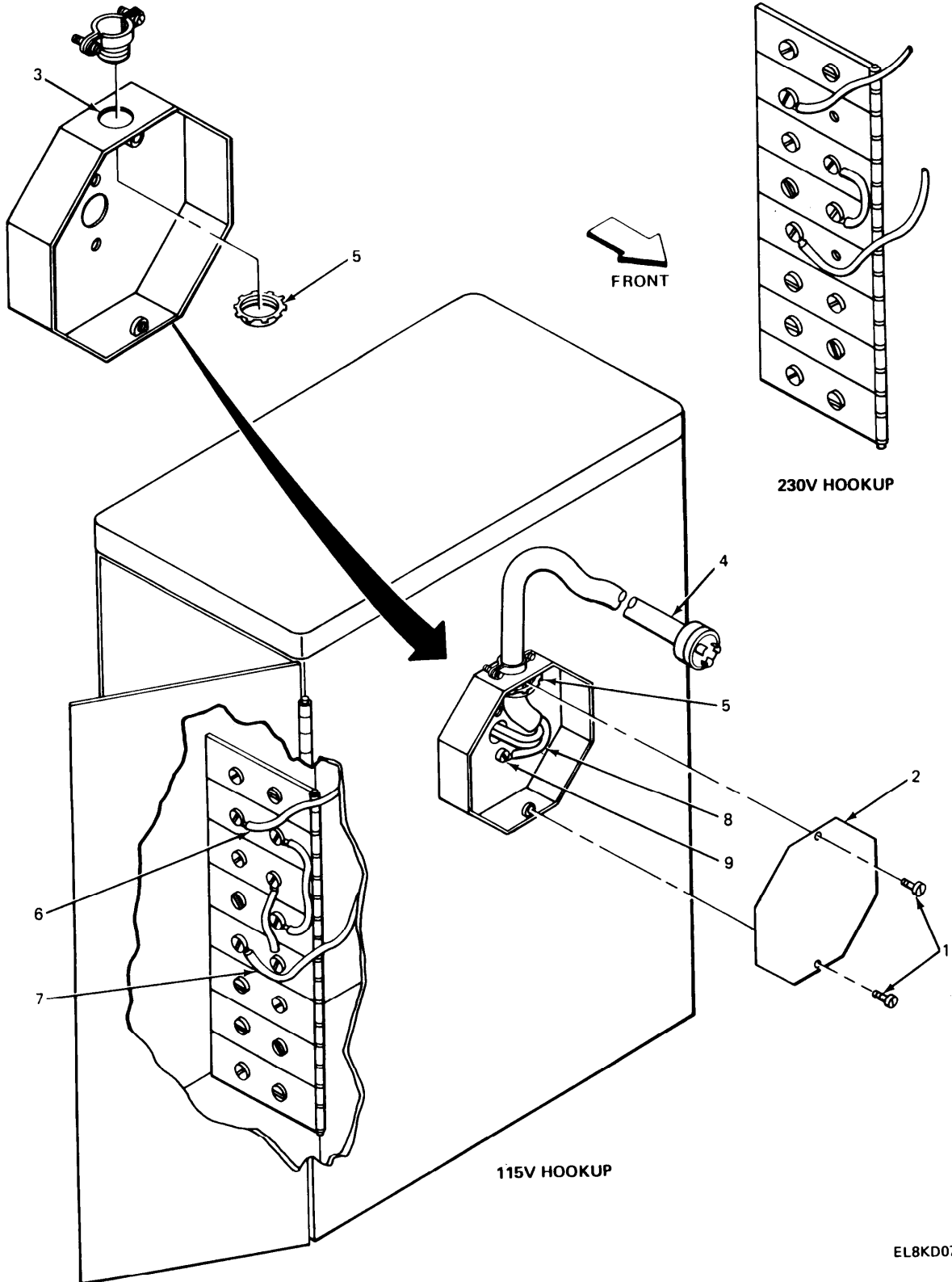

EL8KD070

4-68. REMOVING PP-4763 POWER SUPPLY.

This task covers:

Removal

INITIAL SETUP

Tools

1/2-inch box end wrench

Personnel Required

Two mechanics

Materials/Parts

None

Equipment Condition

All power cables disconnected.

LOCATION	ITEM	ACTION REMARKS
1. Curbside of power supply	Screw (1), lock-washer (2) and flat washer (3)	Using 1/2-inch box wrench, remove. There are three screws. Step 1 is typical for all three screws.
2.	Screws (4)	Do step 1 again.
3. Roadside of power supply	Angle bracket (5)	Do steps 1 and 2 again.
NOTE		
A helper will be needed to lift and remove power supply.		
4.	Power supply (6)	Remove. See paragraph 4-60 for installation.

4-68. REMOVING PP-4763 POWER SUPPLY. (CONT)

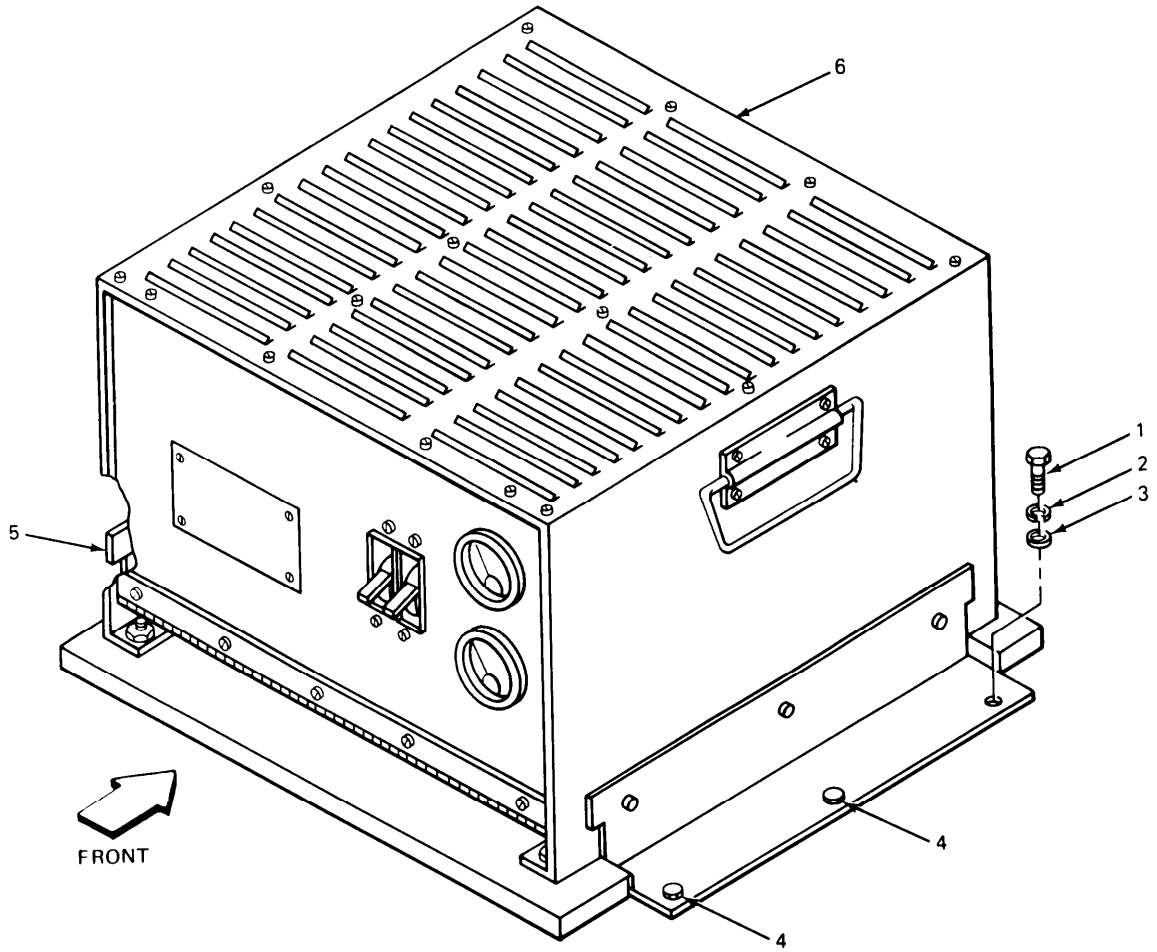

EL8KD071

4-69. REMOVING/INSTALLING HUBBELL CONNECTOR PLUG.

This task covers:

1. Removal
2. Installation

INITIAL SETUP

Tools	Personnel Required
Flat-tip screwdriver	One mechanic
Materials/Parts	Equipment Condition
Hubbell connector plug	Power in vehicle off.

LOCATION	ITEM	ACTION REMARKS
REMOVAL		
1. 4 x 4-inch outlet box	Hubbell connector plug (1)	Unplug.
2. Hubbell connector plug	Insulator disk (2)	Remove.
3.	Screw (3), screw (4) and screw (5)	Using flat-tip screwdriver, loosen.
4.	Black wire (6), white wire (7) and green wire (8)	Remove. Lift wires away from screws.
5.	Screws (9)	Using flat-tip screwdriver, loosen.
6. Power cable	Hubbell connector plug (1)	Remove. For storage, put hardware in cloth bag, attach to Hubbell connector plug and pack in original carton.
INSTALLATION		
1. Power cable	Hubbell connector plug (1) and screws (9)	Using flat-tip screwdriver, install.
2. Hubbell connector plug	Black wire (6) and screw (3)	Using flat-tip screwdriver, install.

4-69. REMOVING/INSTALLING HUBBELL CONNECTOR PLUG. (CONT)

LOCATION	ITEM	ACTION REMARKS
INSTALLATION (CONT)		
3. Hubbell connector plug	White wire (7) and screw (4)	Using flat-tip screwdriver, install.
4.	Green wire (8) and screw (5)	Using flat-tip screwdriver, install.
5.	Insulator disk (2)	Install.

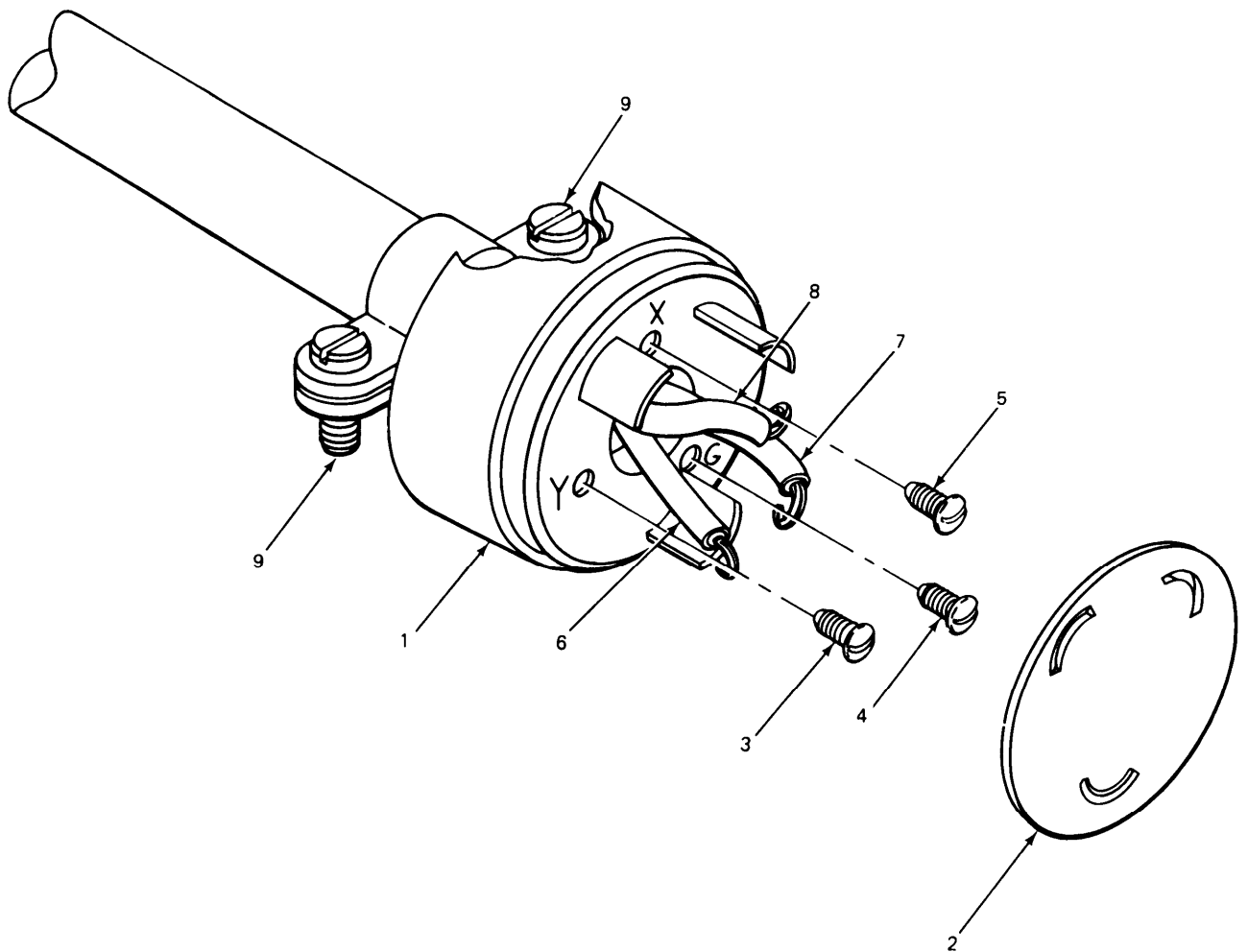

EL8KD076

4-70. REMOVING/INSTALLING POWER CABLE ON POWER SUPPLY.

This task covers:

1. Removal
2. Installation

INITIAL SETUP

Tools	Personnel Required
Flat-tip screwdriver	One mechanic
Materials/Parts	Equipment Condition
5-foot power cable	Power supply removed. Power cable removed. (See paragraphs 4-66 and 4-68.)

LOCATION	ITEM	ACTION REMARKS
REMOVAL		
1. Cable connector	Screws (1)	Using flat-tip screwdriver, loosen.
2. Cable connector	Power cable (2)	Remove.
3. Power cable	Hubbell connector plug (3)	See paragraph 4-69 for removal. For storage, put hardware in cloth bag, attach to power cable, and store in original carton.

INSTALLATION

1. Power cable	Hubbell connector plug (3)	See paragraph 4-56 for preparing and installing Hubbell connector plug.
2. Power supply	Power cable (2)	See paragraphs 4-57 and 4-58 for installation.

NOTE

See paragraphs 4-59 and 4-60 for installation of power supply.
See paragraph 4-61 for installation of dc/dc switch power cable. See paragraph 4-62 for installation of guard assembly.

4-70. REMOVING/INSTALLING POWER CABLE ON POWER SUPPLY. (CONT)

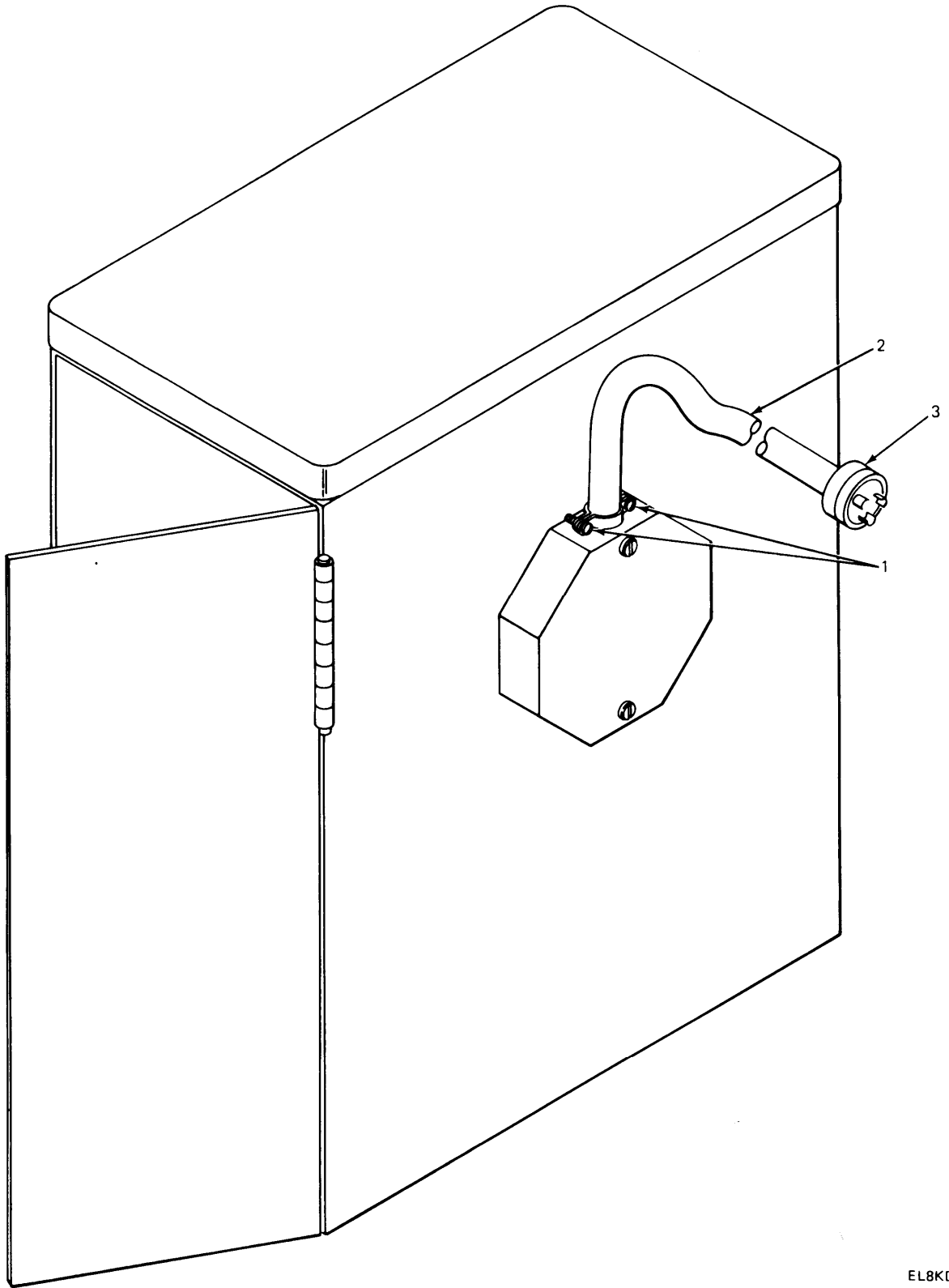

EL8KD077

4-71. REMOVING/INSTALLING RECEPTACLE.

This task covers:

1. Removal
2. Installation

INITIAL SETUP

Tools

Flat-tip screwdriver

Personnel Required

One mechanic

Materials/Parts

Receptacle

Equipment Condition

Circuit breaker No. 19 off. Power supply unplugged.

LOCATION	ITEM	ACTION REMARKS
REMOVAL		
1. 4 x 4-inch outlet box	Screws (1) and face plate (2)	Using flat-tip screwdriver, remove.
2. Face plate	Screws (3) and receptacle (4)	Using flat-tip screwdriver, remove.
3. Receptacle	Screw (5), screw (6) and screw (7)	Using flat-tip screwdriver, loosen.
4.	Black wire (8), white wire (9) and green wire (10)	Remove. Lift wires away from screws.
5.	Receptacle (4)	Remove. For storage put hardware in cloth bag, attach to receptacle and pack in original carton.
INSTALLATION		
1. Face plate	Receptacle (4) and screws (3)	Using flat-tip screwdriver, install,

4-71. REMOVING/INSTALLING RECEPTACLE. (CONT)

LOCATION	ITEM	ACTION REMARKS
INSTALLATION (CONT)		
2. Receptacle	Blace wire (8) and screw (5)	Using flat-tip screwdriver, install.
3.	White wire (9) and screw (6)	Using flat-tip screwdriver, install.
4. Receptacle	Green wire (10) and screw (7)	Using flat-tip screwdriver, install.
5. 4 x 4-inch outlet box	Face plate (2) and screws (1)	Using flat-tip screwdriver, install.

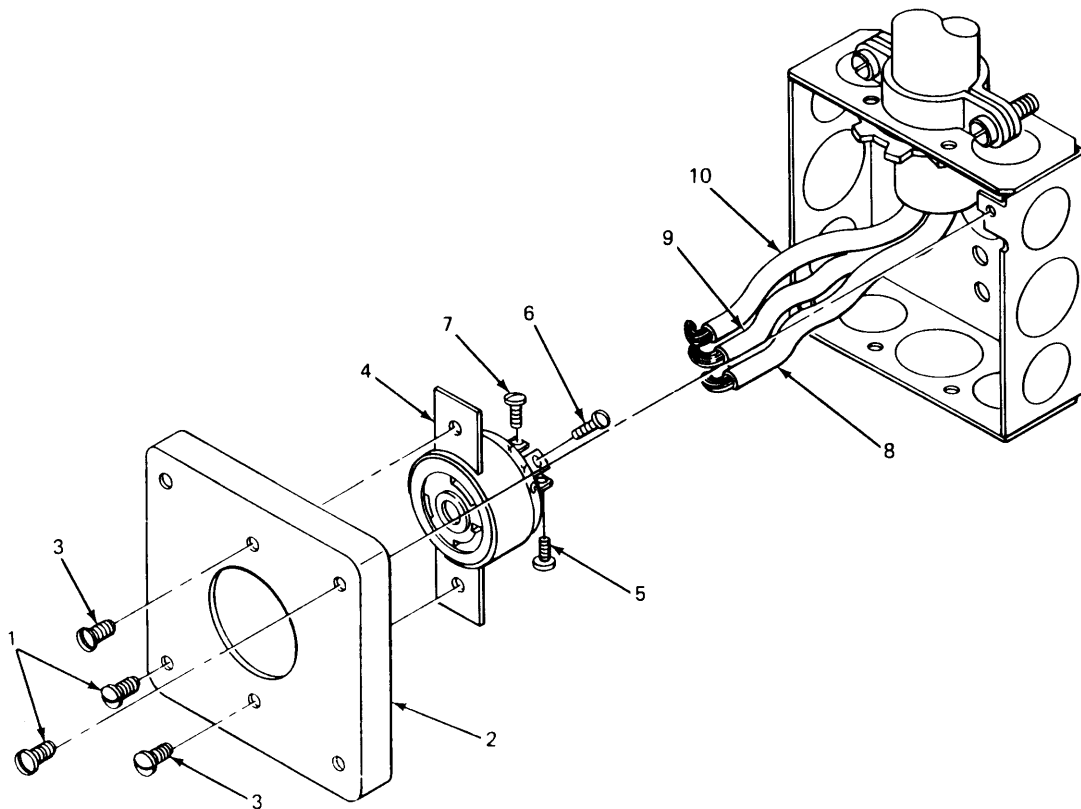

EL8KD078

4-72. REMOVING/INSTALLING 4 X 4-INCH OUTLET BOX.

This task covers:

- 1. Removal
- 2. Installation

INITIAL SETUP

Tools

- Flat-tip screwdriver
- Pliers

Materials/Parts

None

Personnel Required

One mechanic

Equipment Condition

See paragraph 4-71 for removal of faceplate and receptacle.

LOCATION	ITEM	ACTION REMARKS
1. Cable connector	Screws (1)	Using flat-tip screwdriver, loosen.
2.	Power cable (2)	Remove.
3. Inside 4 x 4-inch outlet box	Conduit lock-nut (3)	Using pliers, remove.
4. Outlet box	Cable connector (4)	Remove.
5.	Screws (5)	Using flat-tip screwdriver, remove.
6.	Outlet box (6)	Remove. For storage, put hardware in cloth bag, attach to outlet box and store in original carton.

INSTALLATION

- 1. Curbside forward wall
Outlet box (6), cable connector (4) and conduit locknut (3)
See paragraph 4-52 for installation.
- 2. Top of outlet box
Cable connector (4)
Put power cable into cable connector.

4-72. REMOVING/INSTALLING 4 X 4-INCH OUTLET BOX. (CONT)

LOCATION	ITEM	ACTION REMARKS
INSTALLATION (CONT)		
3. Cable connector	Screws (1)	Using flat-tip screwdriver, tighten.

NOTE

See paragraph 4-71 for installation of receptacle and face-plate.

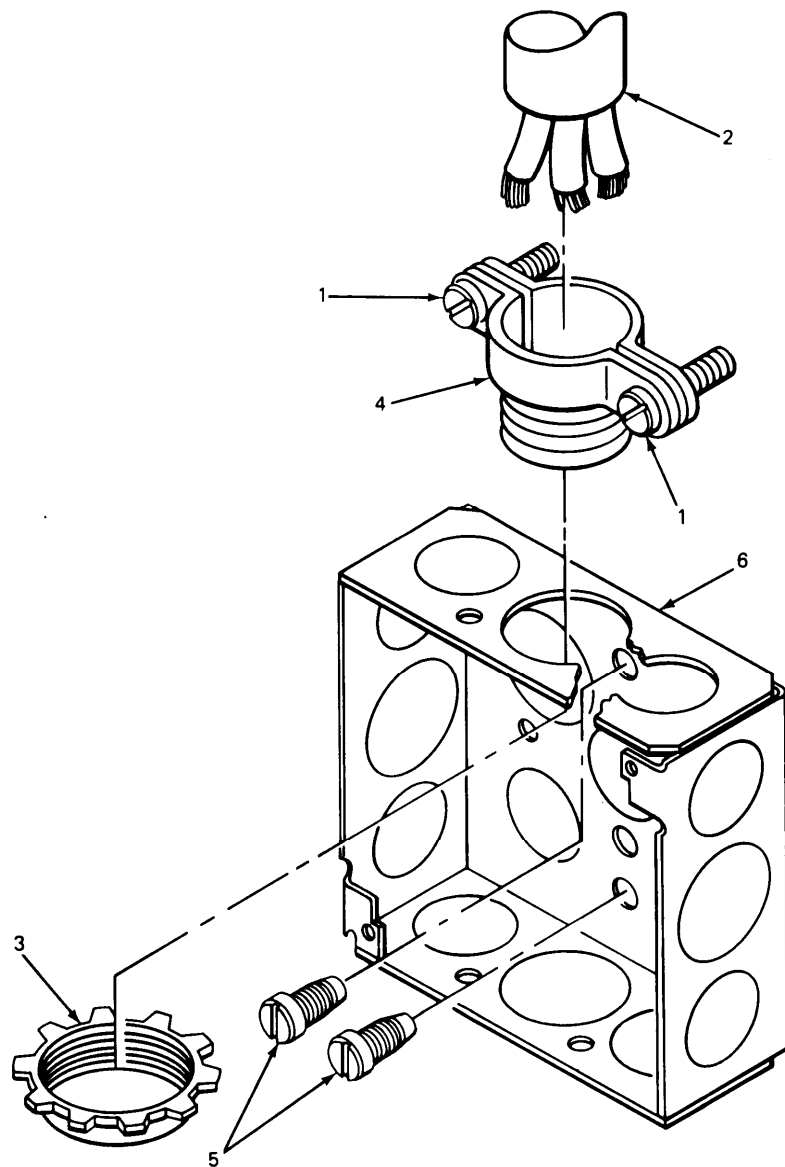

EL8KD079

4-73. REMOVING 26-FOOT POWER CABLE.

This task covers:

Removal

INITIAL SETUP

Tools

Flat-tip screwdriver

Materials/Parts

Power cable 26-feet long

Personnel Required

One mechanic

Equipment Condition

See paragraph 4-71 for removal of faceplate and receptacle.

LOCATION	ITEM	ACTION REMARKS
----------	------	-------------------

REMOVAL

WARNING

All power in vehicle must be off.

- | | | |
|----------------------------------|--|---|
| 1. Cable connector | Screws (1) | Using flat-tip screwdriver, loosen. |
| 2. | Power cable (2) | Remove. |
| 3. Forward wall | Screw (3), flat washer (4) and cable clamp (5) | Using flat-tip screwdriver, remove. There are four cable clamps. Step 3 is typical for all four cable clamps. |
| 4. | Cable clamps (6) | Do step 3 again. |
| 5. | Nylon ties (7) | Remove. |
| 6. Ceiling, next to forward wall | Screw (8), flat washer (9), cable clamp (10) and power cable (2) | Using flat-tip screwdriver, remove. |

NOTE

Do step 5 again for each cable clamp and hardware until circuit breaker box is reached.

4-73. REMOVING 26-FOOT POWER CABLE. (CONT)

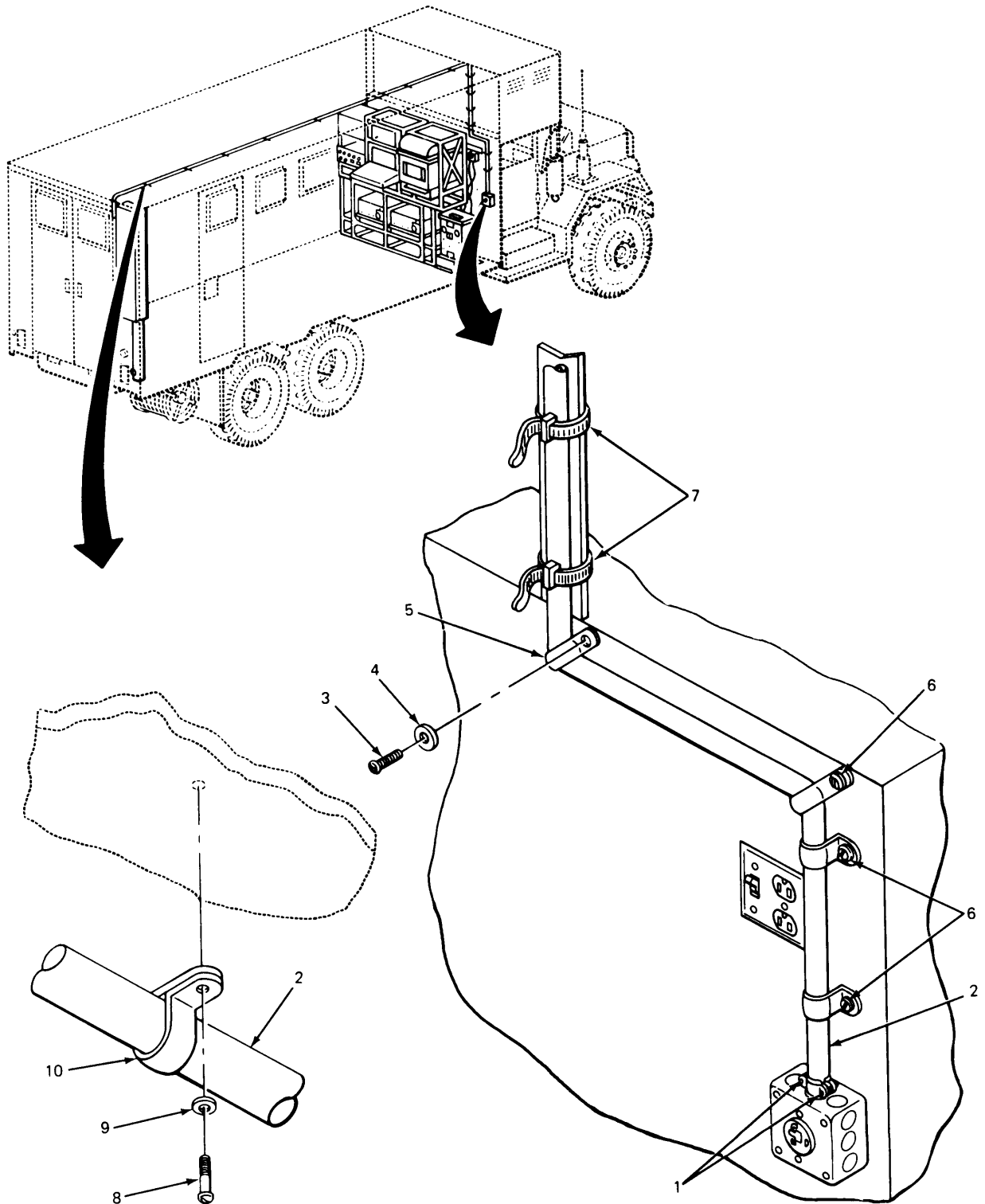

EL8KD080

4-73. REMOVING 26-FOOT POWER CABLE. (CONT)

LOCATION	ITEM	ACTION REMARKS
REMOVAL (CONT)		
6. Circuit breaker box	Screws (1) and circuit breaker box cover (2)	Using flat-tip screwdriver, remove.
7. Circuit breaker No. 19	Screw (3)	Using flat-tip screwdriver, loosen.
8.	Black wire (4)	Remove.
g. Neutral strip	Screw (5)	Using flat-tip screwdriver, loosen.
10.	White wire (6)	Remove.
11.	Screw (7) and green wire (8)	Using flat-tip screwdriver, remove.
12. 90° cable connector	Screws (9)	Using flat-tip screwdriver, loosen.
13.	Power cable (10)	Remove. For storage, put hardware in cloth bag, attach to power cable and pack in original carton.

NOTE

See paragraphs 4-50 and 4-51 for installation of power cable.

4-74. REMOVING/INSTALLING CIRCUIT BREAKER.

This task covers:

1. Removal
2. Installation

INITIAL SETUP

Tools

Flat-tip screwdriver

Materials/Parts

30-amp circuit breaker

Personnel Required

One mechanic

Equipment Condition

All power in vehicle off.

LOCATION	ITEM	ACTION REMARKS
----------	------	-------------------

REMOVAL

1. Circuit breaker box	Screws (1) and circuit breaker box cover (2)	Using flat-tip screwdriver, remove.
2. Circuit breaker No. 19	Screw (3)	Using flat-tip screwdriver, loosen.
3.	Black wire (4)	Remove.
4.	Screw (5)	Using flat-tip screwdriver, loosen.
5. Circuit breaker box	Circuit breaker (6)	Remove. For storage, put hardware in cloth bag, attach to circuit breaker and pack in original carton.

INSTALLATION

1. Position No. 19	Circuit breaker (6) and screw (5)	Using flat-tip screwdriver, install.
2. Circuit breaker No. 19	Black wire (4) and screw (3)	Using flat-tip screwdriver, install.
3.	Circuit breaker box cover (2) and screws (1)	Using flat-tip screwdriver, install.

4-74 REMOVING/INSTALLING CIRCUIT BREAKER. (CONT)

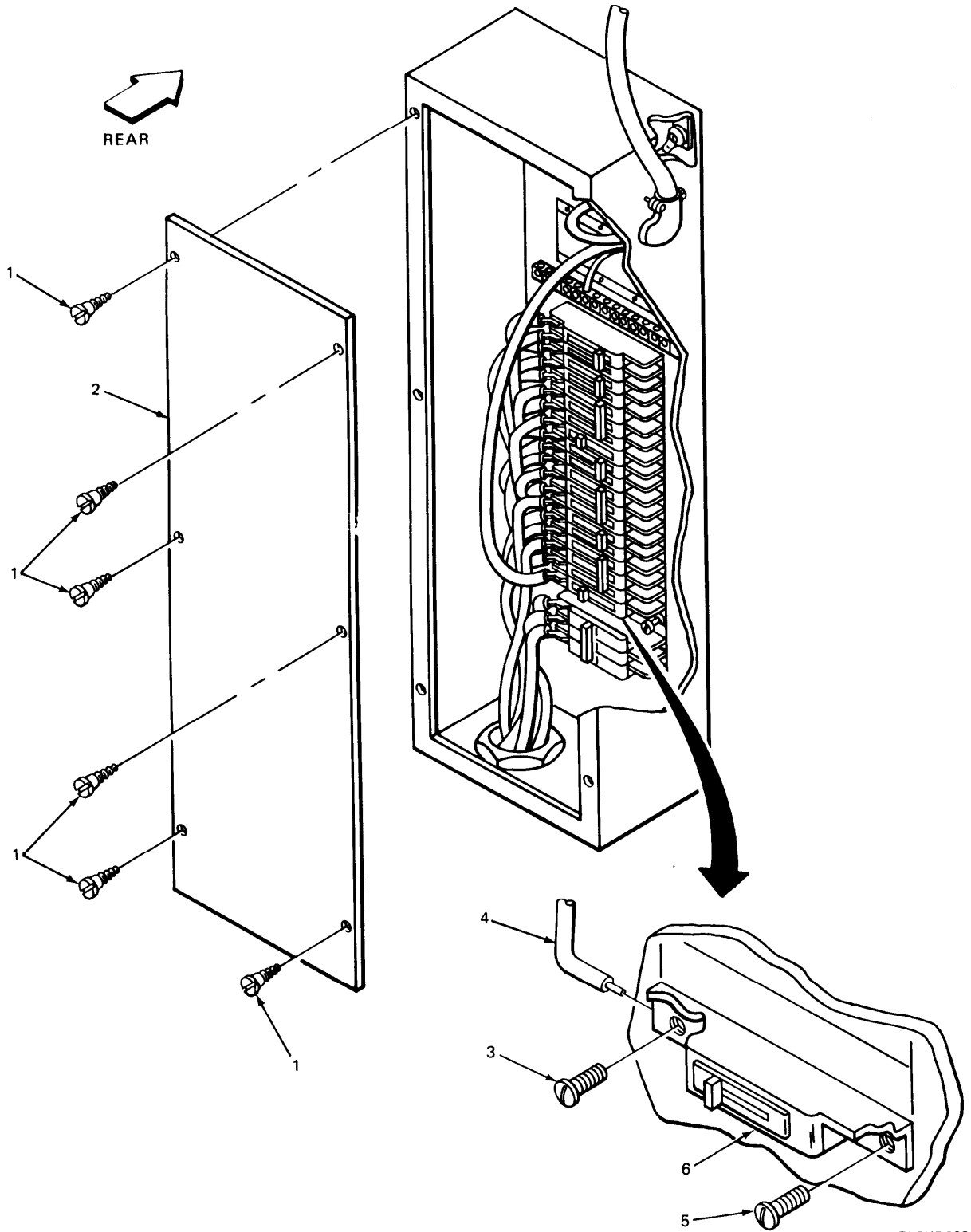

EL8KD082

4-75. REMOVING/INSTALLING 90° CABLE CONNECTOR.

This task covers:

1. Removal
2. Installation

INITIAL SETUP

Tools

- Pliers
- Flat-tip screwdriver

Materials/Parts

- 900 cable connector

Personnel Required

One mechanic

Equipment Condition

All power in vehicle off.

LOCATION	ITEM	ACTION REMARKS
REMOVAL		
1. Circuit breaker box	Screws (1) and circuit breaker box cover (2)	Using flat-tip screwdriver, remove.
2. Circuit breaker No. 19	Screws (3)	Using flat-tip screwdriver, loosen.
3.	Black wire (4)	Remove.
4. Neutral strip	Screw (5)	Using flat-tip screwdriver, loosen.
5.	White wire (6)	Remove.
6. Grounding block	Screw (7) and green wire (8)	Using flat-tip screwdriver, remove.
7. 90° cable connector	Screws (9)	Using flat-tip screwdriver, loosen.
8.	Power cable (10)	Remove.
9. Roadside of circuit breaker box	Conduit lock-nut (11) and 90° cable connector (12)	Using pliers, remove. For storage, put hardware in cloth bag, attach to 90° cable connector and pack in original carton.

4-75. REMOVING/INSTALLING 90° CABLE CONNECTOR. (CONT)

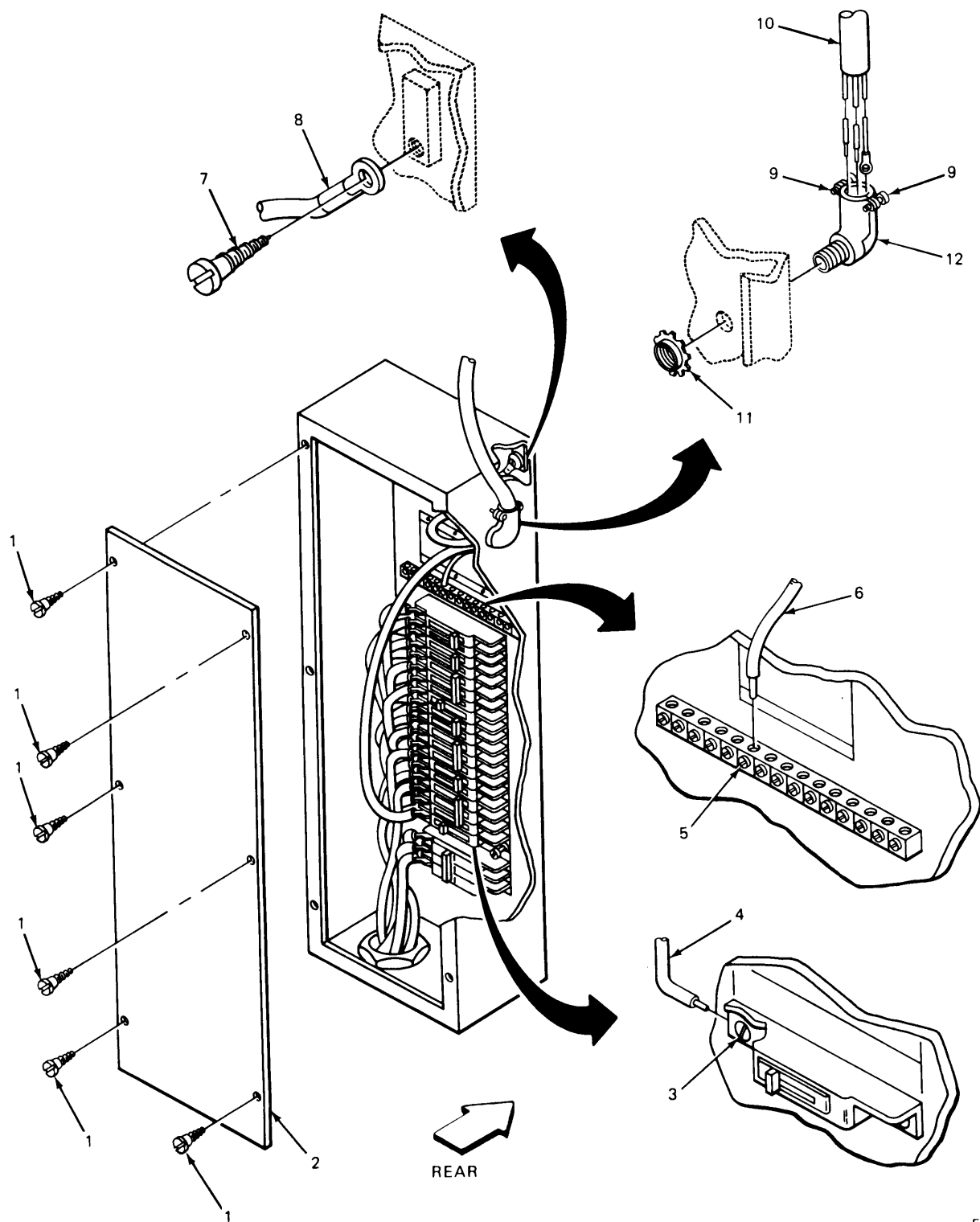

EL8KD083

4-75. REMOVING/INSTALLING 90° CABLE CONNECTOR. (CONT)

LOCATION	ITEM	ACTION REMARKS
INSTALLATION		
1. Roadside of circuit breaker box	90° cable connector (1) and conduit locknut (2)	Using pliers, install.
2. 90° cable connector	Power cable (3) and screws (4)	Using flat-tip screwdriver, install.
3. Grounding block	Green wire (5) and screw (6)	Using flat-tip screwdriver, install.
4. Neutral strip	White wire (7) and screw (8)	Using flat-tip screwdriver, install.
5. Circuit breaker No. 19	Black wire (9) and screw (10)	Using flat-tip screwdriver, install.
6. Circuit breaker box	Circuit breaker box cover (11) and screws (12)	Using flat-tip screwdriver, install.

4-75. REMOVING/INSTALLING 90° CABLE CONNECTOR. (CONT)

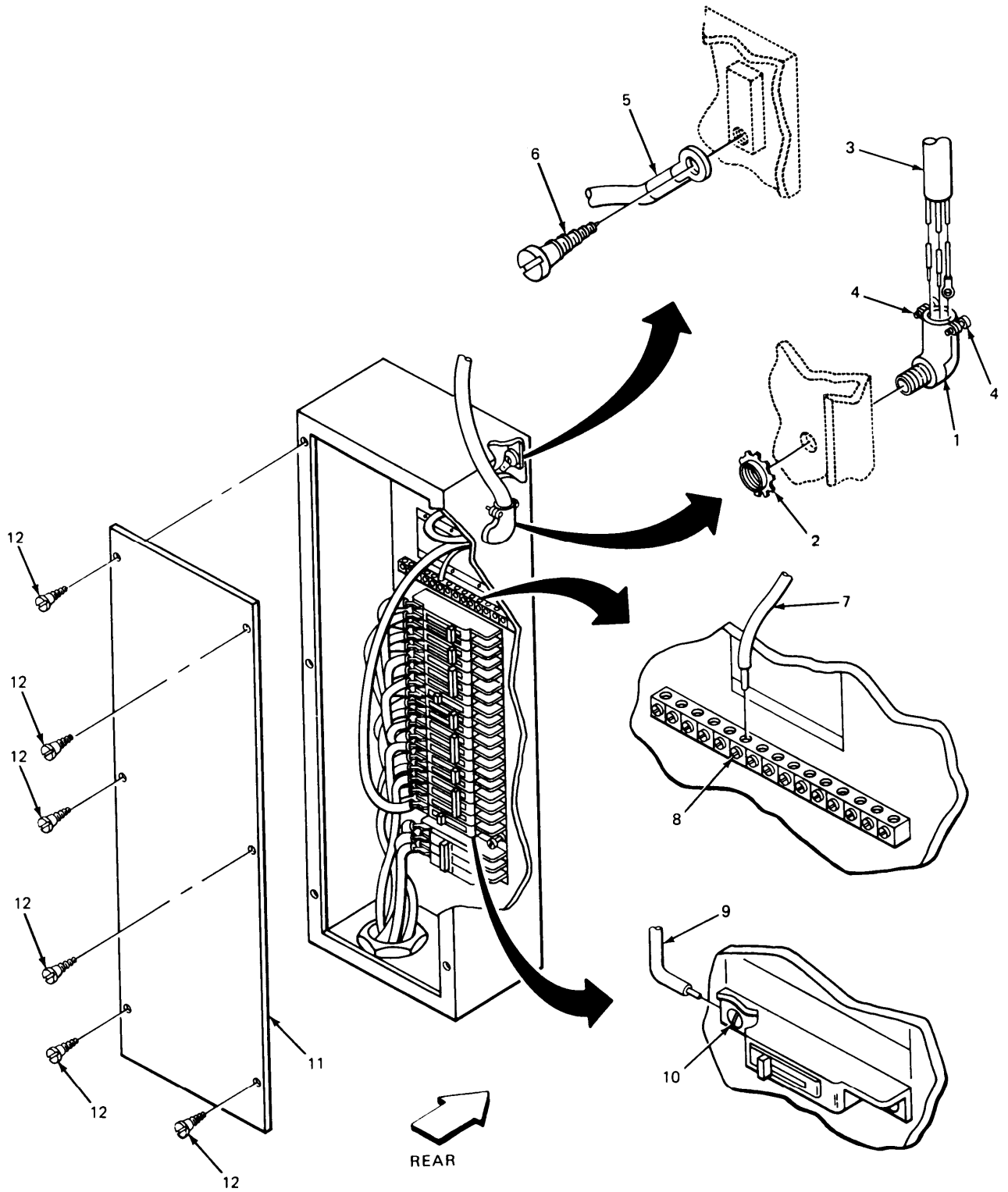

EL8KD084

4-76. REMOVING PIPE NIPPLE.

This task covers:

Removal

INITIAL SETUP

Tools

Personnel Required

Pliers

One mechanic

Materials/Parts

Equipment Condition

None

Cables removed from pipe nipple.

LOCATION	ITEM	ACTION REMARKS
1. Inside and outside of vehicle forward wall on pipe nipple	Insulator bushings (1)	Remove.
2.	Conduit lock-nuts (2)	Using pliers, remove.
3.	Aluminum washers (3)	Remove.
4. Forward wall	Pipe nipple (4)	Remove.
5.	Pipe nipple (4)	See paragraph 4-29 for installation. For storage, place hardware in cloth bag, attach to pipe nipple and pack in original carton.

4-76. REMOVING PIPE NIPPLE. (CONT)

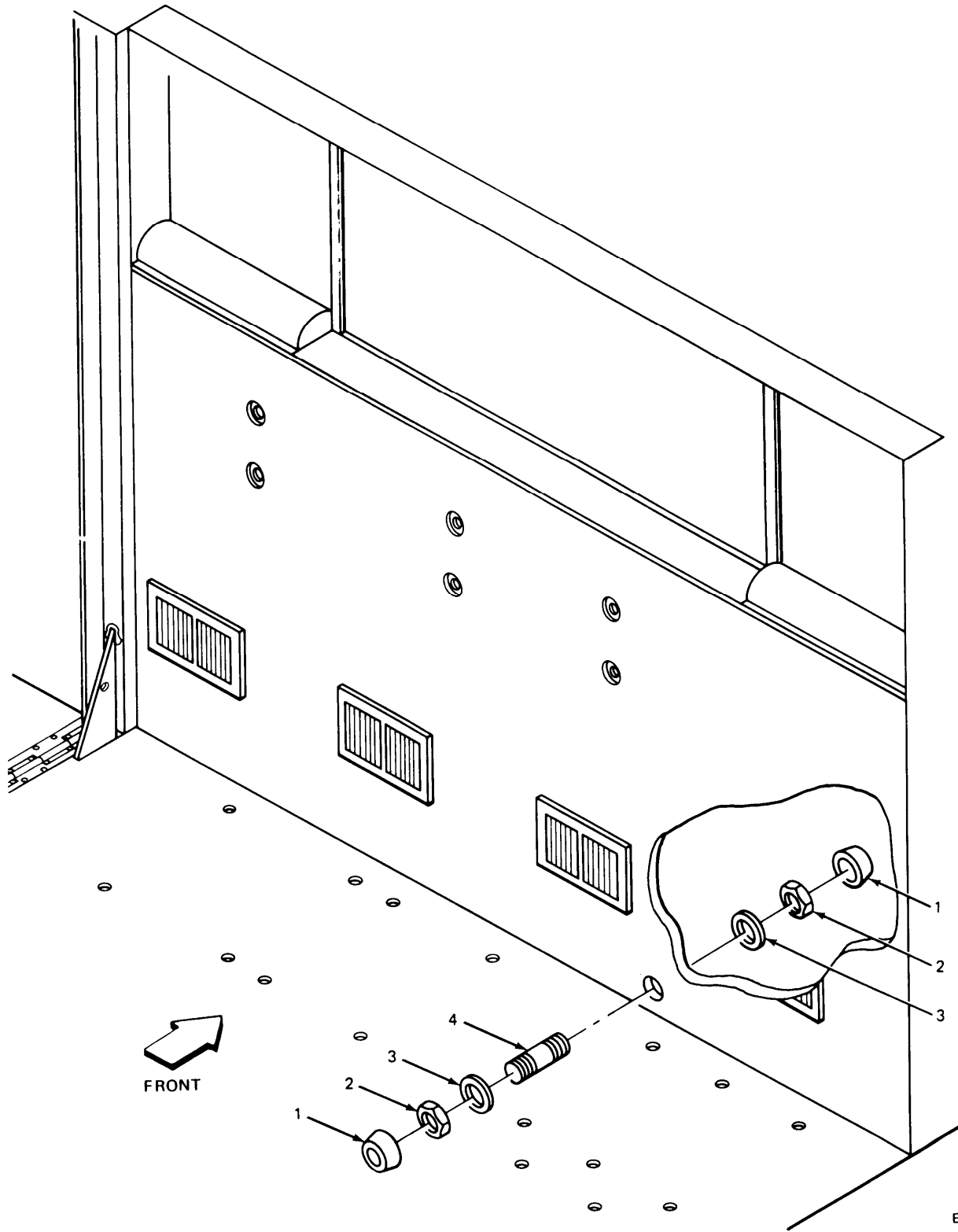

EL8KD085

4-77. REMOVING/INSTALLING DC/DC SWITCH.

This task covers:

1. Removal
2. Installation

INITIAL SETUP

Tools

- Pliers
- 1/2-inch box wrench

Materials/Parts

- DC/DC switch

Personnel Required

One mechanic

Equipment Condition

DC/DC switch cables disconnected.
Guard assembly removed.
(See paragraph 4-64.)

LOCATION	ITEM	ACTION REMARKS
----------	------	-------------------

REMOVAL

NOTE

Refer to TM 11-7440-251-10 and TM 11-7440-253-10-1 for completing the removal of cables.

1.	DC/DC switch	Wingnuts (1)	Using pliers, remove.
2.		DC/DC switch power cable (2)	Remove. Remove both wires.
3.		Screw (3), lock-washer (4) and flat washer (5)	Using 1/2-inch box wrench, remove. There are four screws. Step 5 is typical for all four screws.
4.		Screws (6)	Do step 5 again,
5.		DC/DC switch (7)	Remove. For storage, place hardware in cloth bag, attach to dc/dc switch and pack in original carton.

4.77. REMOVING/INSTALLING DC/DC SWITCH. (CONT)

LOCATION	ITEM	ACTION REMARKS
----------	------	-------------------

INSTALLATION

- | | | |
|--------------------------|------------------------------|--|
| 1. Forward wall | DC/DC switch (7) | See paragraphs 4-34 and 4-35 for installation and routing cables. |
| 2. Front or power supply | DC/DC switch power cable (2) | Using pliers, install.
Positive wire connects to positive terminal. Negative wire connects to negative terminal. |
| 3. | Guard assembly | See paragraph 4-62 for installation. |

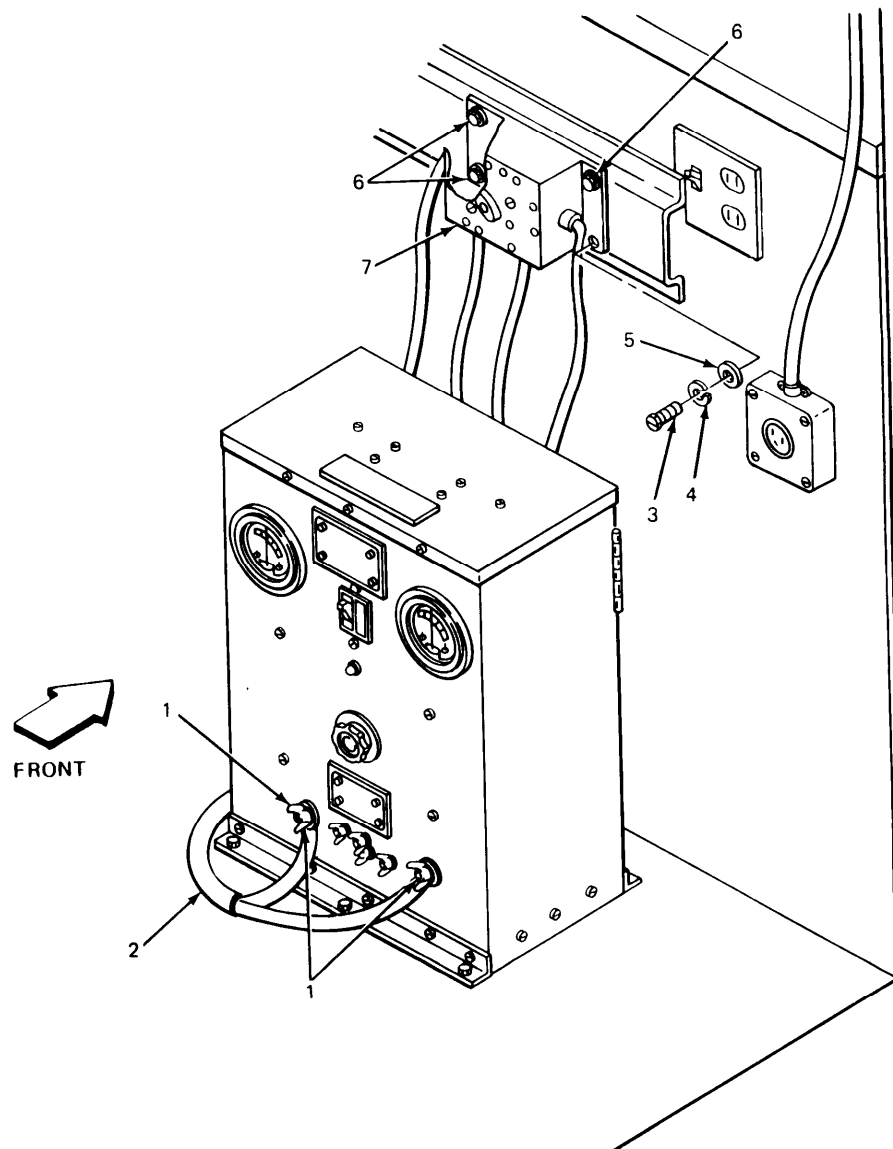

4-78. REMOVING TACFIRE COMPONENTS.

This task covers:

Removal

INITIAL SETUP

Tools

None

Personnel Required

One mechanic

Materials/Parts

None

Equipment Condition

All power in vehicle off.

LOCATION	ITEM	ACTION REMARKS
1. Tacfire rack	Tacfire components (1)	Remove the tacfire components in accordance with TM 11-7440-251-10 and TM 11-7440-253-10-1. For storage, put hardware in cloth bag, attach to tacfire components and pack in original cartons.
2.	Tacfire components (1)	See paragraph 4-30 for installation.

4-78. REMOVING TACFIRE COMPONENTS. (CONT)

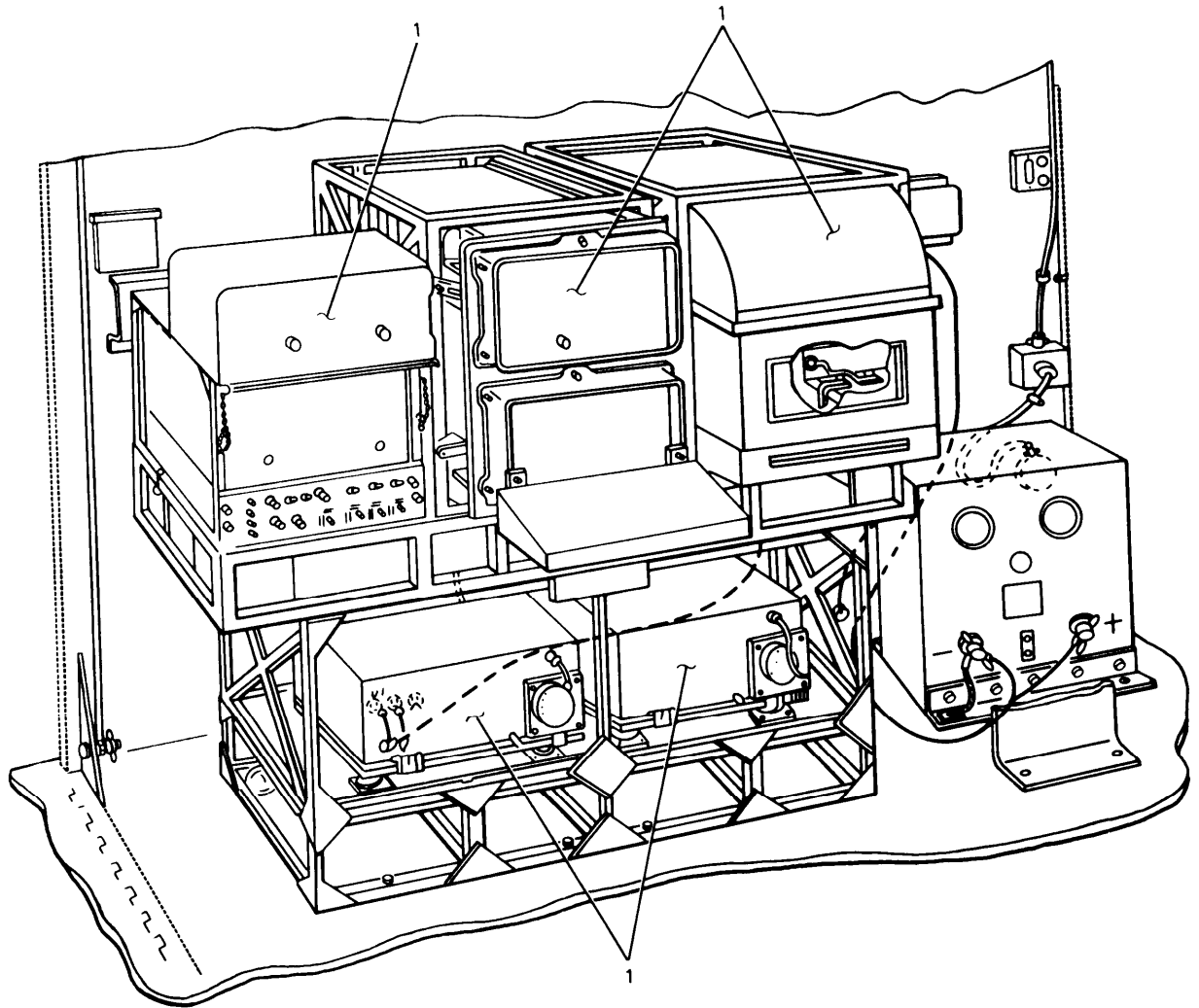

FRONT

EL8KD087

4-79. REMOVING 30-INCH GROUND STRAP.

This task covers:

Removal

INITIAL SETUP

Tools

Pliers
Flat-tip screwdriver

Personnel Required

One mechanic

Materials/Parts

None

Equipment Condition

All power in vehicle off,

LOCATION	ITEM	ACTION REMARKS
1. Lower gusset plate roadside position	Wingnut (1), IT lockwasher (2) and 30-inch ground strap (3)	Using pliers, remove.
2. Rear of power distribution box	Wingnut (4), IT lockwasher (5) and 30 inch ground strap (3)	Using pliers, remove. For storage, put hardware in cloth bag, attach to 30-inch ground strap and pack in original carton.
3. Roadside lower gusset plate and rear of power distribution box	30-inch ground strap (3)	See paragraph 4-36 for installation.
4. Key generator rack	Power distribution box (7)	Using flat-tip screwdriver, loosen.
5.	Captive screws (6) and power distribution box (7)	Remove.

4-79. REMOVING 30-INCH GROUND STRAP. (CONT)

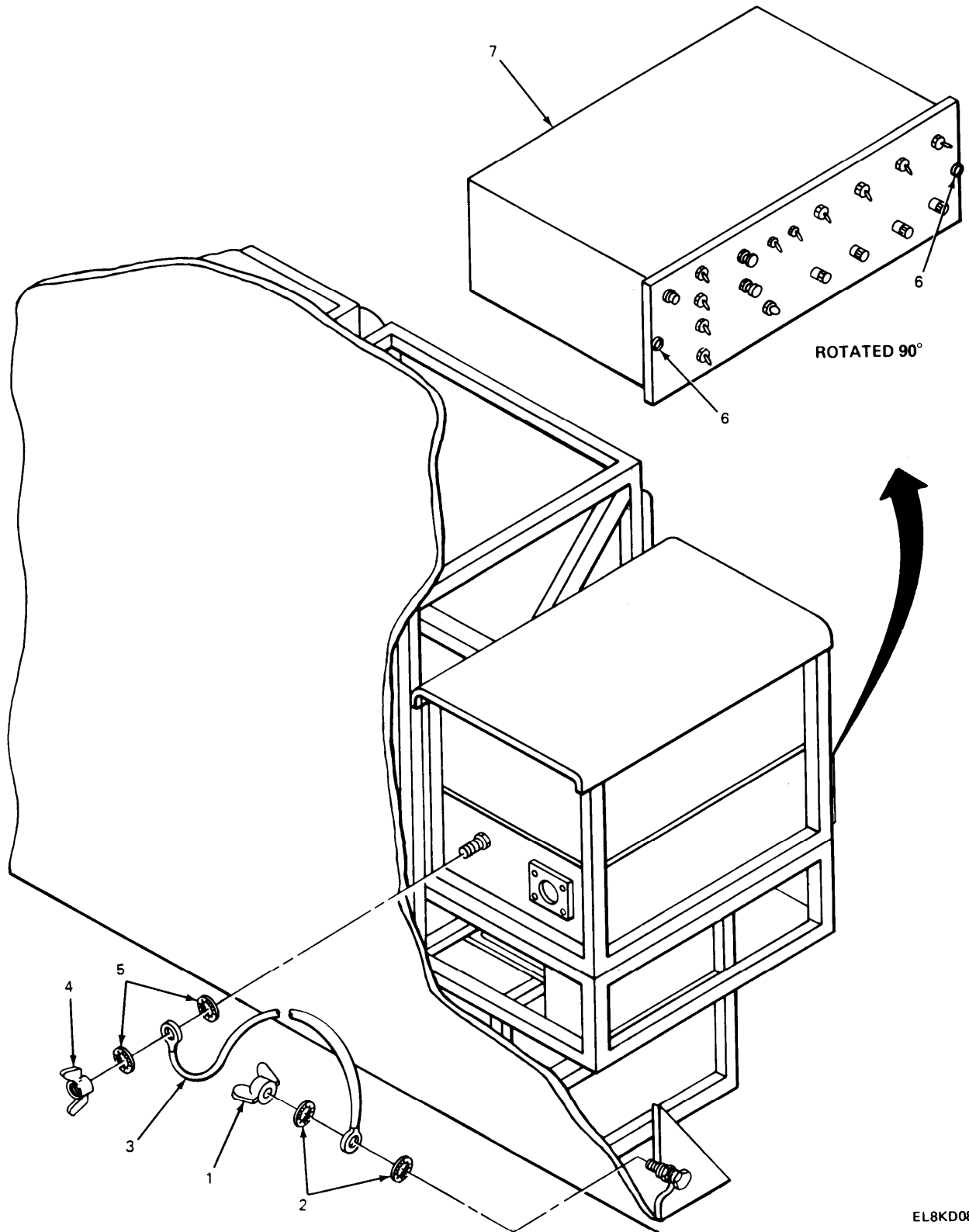

EL8KD088

4-80. REMOVING 4-INCH GROUND STRAPS.

This task covers:

Removal

INITIAL SETUP

Tools

Channel lock pliers

Personnel Required

One mechanic

Materials/Parts

None

Equipment Condition

Tacfire components removed.
(See paragraph 4-78.)

LOCATION	ITEM	ACTION REMARKS
1. Curbside, lower support on electronic line printer rack	Wingnut (1), IT lockwashers (2) and 4-inch ground strap (3)	Using pliers, remove.
2. Curbside, upper support on electronic equipment table	Wingnut (4), IT lockwashers (5) and 4-inch ground strap (3)	Using pliers, remove.
NOTE		
There are seven 4-inch ground straps. Steps 1 and 2 are typical for all seven 4-inch ground straps.		
3. Electronic equipment racks	4-inch ground straps (6)	Do steps 1 and 2 again. For storage, put hardware and 4 inch ground straps in cloth bag, pack in original carton.
4.	4-inch ground straps (6)	See paragraph 4-11 for installation.

4-80. REMOVING 4-INCH GROUND STRAPS. (CONT)

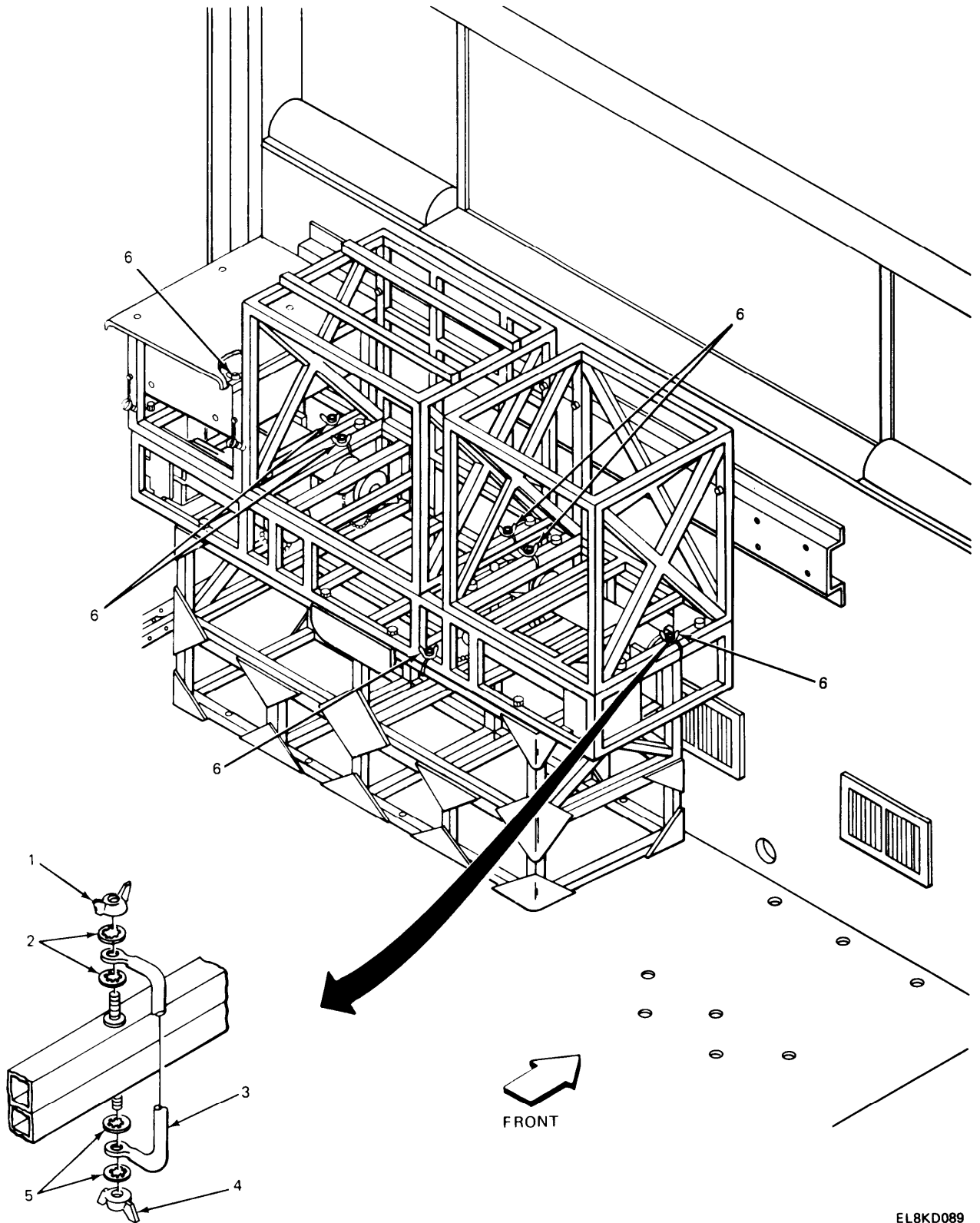

EL8KD089

4-81. REMOVING/INSTALLING ELECTRONIC LINE PRINTER RACK.

This task covers:

1. Removal
2. Installation

INITIAL SETUP

Tools

1/2-inch box wrench (2 required)

Personnel Required

One mechanic

Materials/Parts

Electronic printer rack

Equipment Condition

All power in vehicle off.
4-inch ground straps removed.
(See paragraph 4-80.)

LOCATION	ITEM	ACTION REMARKS
----------	------	-------------------

REMOVAL

NOTE

See TM 11-7440-251-10 and TM 11-7440-253-10-1 for removal of electronic line printer.

- | | | |
|---|---|--|
| 1. Lower supports of electronic line printer rack | Screw (1), flat washers (2) and nut (3) | Using two 1/2-inch box wrenches, remove.
There are four screws. Step 1 is typical for all four screws. |
| 2. | Screws (4) | Do step 1 again. |
| 3. Curbside, vertical support | Screw (5), lock-washer (6) and flat washer (7) | Using 1/2-inch box wrench, remove. |
| 4. Roadside, vertical support | Screw (8), lock-washer (9) and flat washer (10) | Using 1/2-inch box wrench, remove. |
| 5. Curbside, tacfire rack | Electronic line printer rack (11) | Remove.
For storage, put in cloth bag, attach to electronic line printer. |

4-81. REMOVING/INSTALLING ELECTRONIC LINE PRINTER RACK. (CONT)

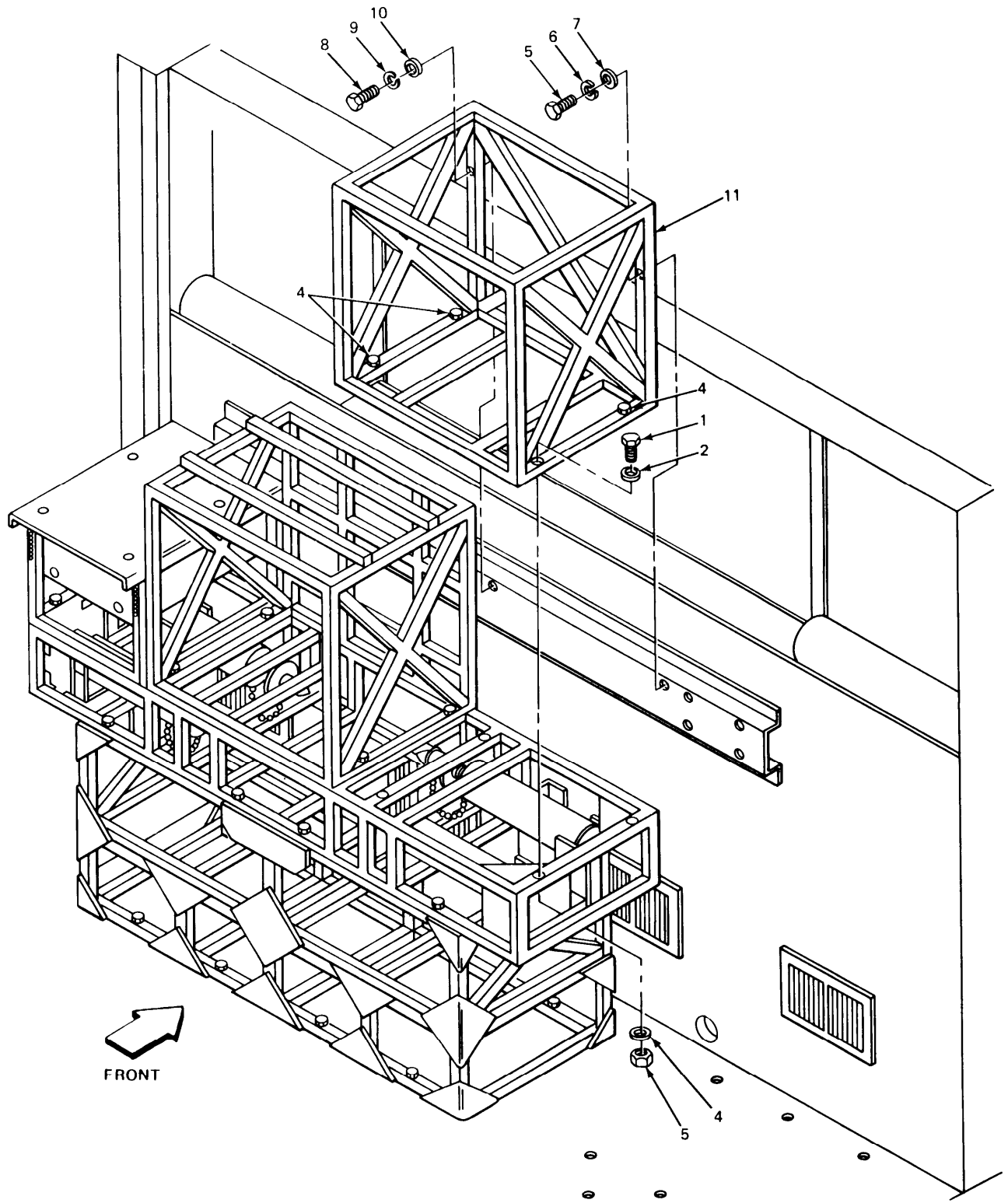

EL8KD090

4-81. REMOVING/INSTALLING ELECTRONIC LINE PRINTER RACK. (CONT)

LOCATION	ITEM	ACTION REMARKS
INSTALLATION		
1. Curbside, on top of electronic equipment table	Electronic line printer rack (1) and electronic equipment table (2)	Put electronic line printer rack on top of electronic equipment table and align holes.
2. Lower supports on electronic line printer rack	Screw (3), flat washers (4) and nut (5)	Install, handtighten. There are four screws. Step 2 is typical for all four screws.
3.	Screw holes (6)	Do step 2 again.
4. Curbside, vertical support	Screw (7), lock-washer (8) and flat washer (9)	Install, handtighten.
5. Roadside, vertical support	Screw (10), lock-washer (11) and flat washer (13)	Install, handtighten.

NOTE

Using two 1/2-inch box wrenches, tighten all screws.

6. Lower supports	4-inch ground straps	See paragraph 4-11 for installation.
-------------------	----------------------	--------------------------------------

NOTE

See TM 11-7440-251-10 and TM 11-7440-253-10-1 for installation of electronic line printer.

4-81. REMOVING/INSTALLING ELECTRONIC LINE PRINTER RACK. (CONT)

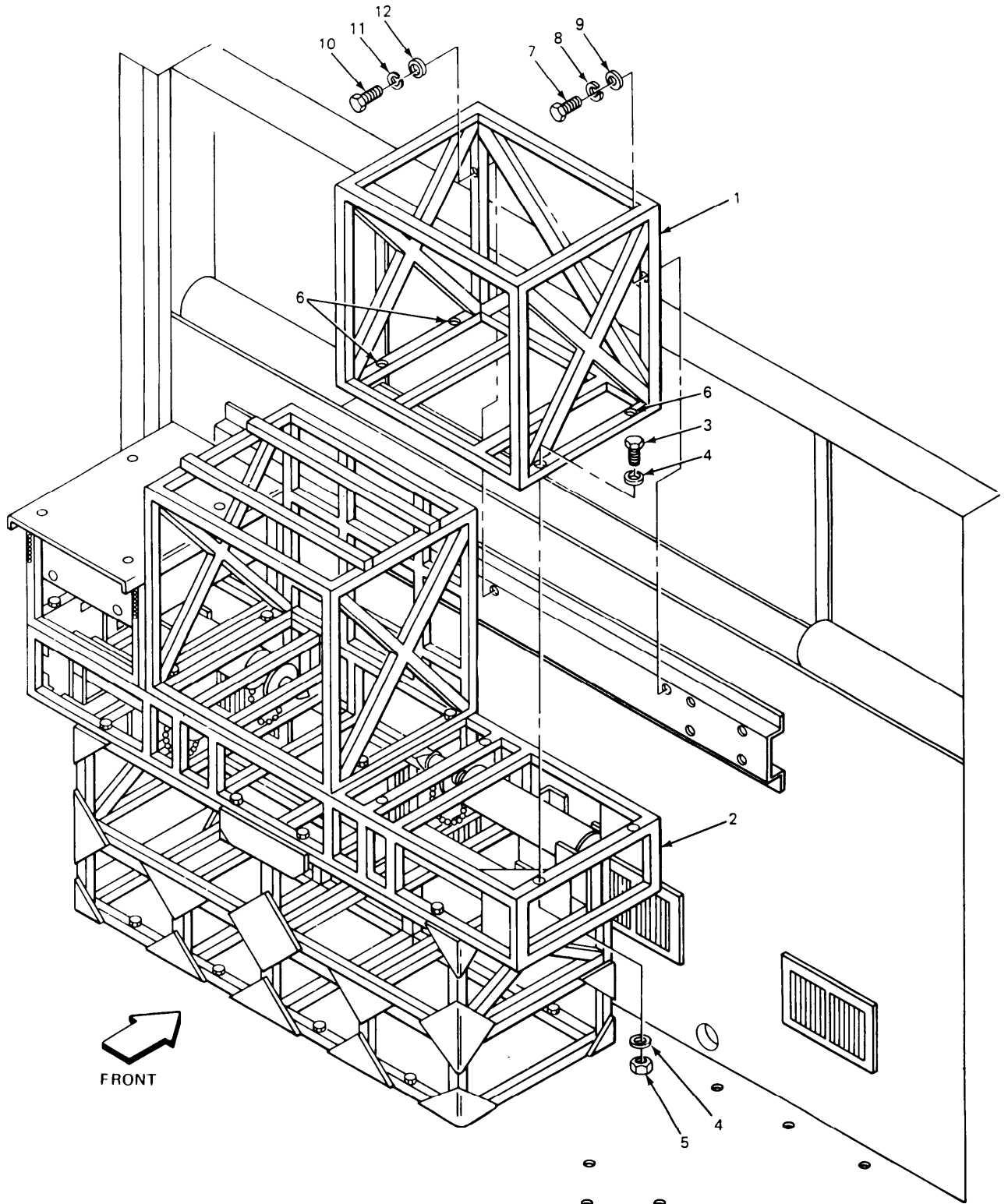

EL8KD091

4-82. REMOVING/INSTALLING MESSAGE ENTRY GROUP RACK.

This task covers:

1. Removal
2. Installation

INITIAL SETUP

Tools

1/2-inch box wrench (2 required)

Personnel Required

One mechanic

Materials/Parts

Message entry group rack

Equipment Condition

All power in vehicle off.
4-inch ground straps removed.
(See paragraph 4-80.)

LOCATION

ITEM

ACTION
REMARKS

REMOVAL

NOTE

See TM 11-7440-251-10 and TM 11-7440-253-10-1 for removal of message entry group.

- | | | | |
|----|--|---|---|
| 1. | Lower supports of message entry group rack | Screw (1), flat washers (2) and nut (3) | Using two 1/2 inch box wrenches, remove.
There are four screws. Step 1 is typical for all four screws. |
| 2. | | Screws (4) | Do step 1 again. |
| 3. | Curbside, vertical support | Screw (5), lock-washer (6) and flat washer (7) | Using 1/2-inch box wrench, remove. |
| 4. | Roadside, vertical support | Screw (8), lock-washer (9) and flat washer (10) | Using 1/2-inch box wrench, remove. |
| 5. | Center position, tacfire rack | Message entry group rack (11) | Remove.
For storage, put hardware in cloth bag. Attach to message entry group rack and pack in original carton. |

4-82. REMOVING/INSTALLING MESSAGE ENTRY GROUP RACK. (CONT)

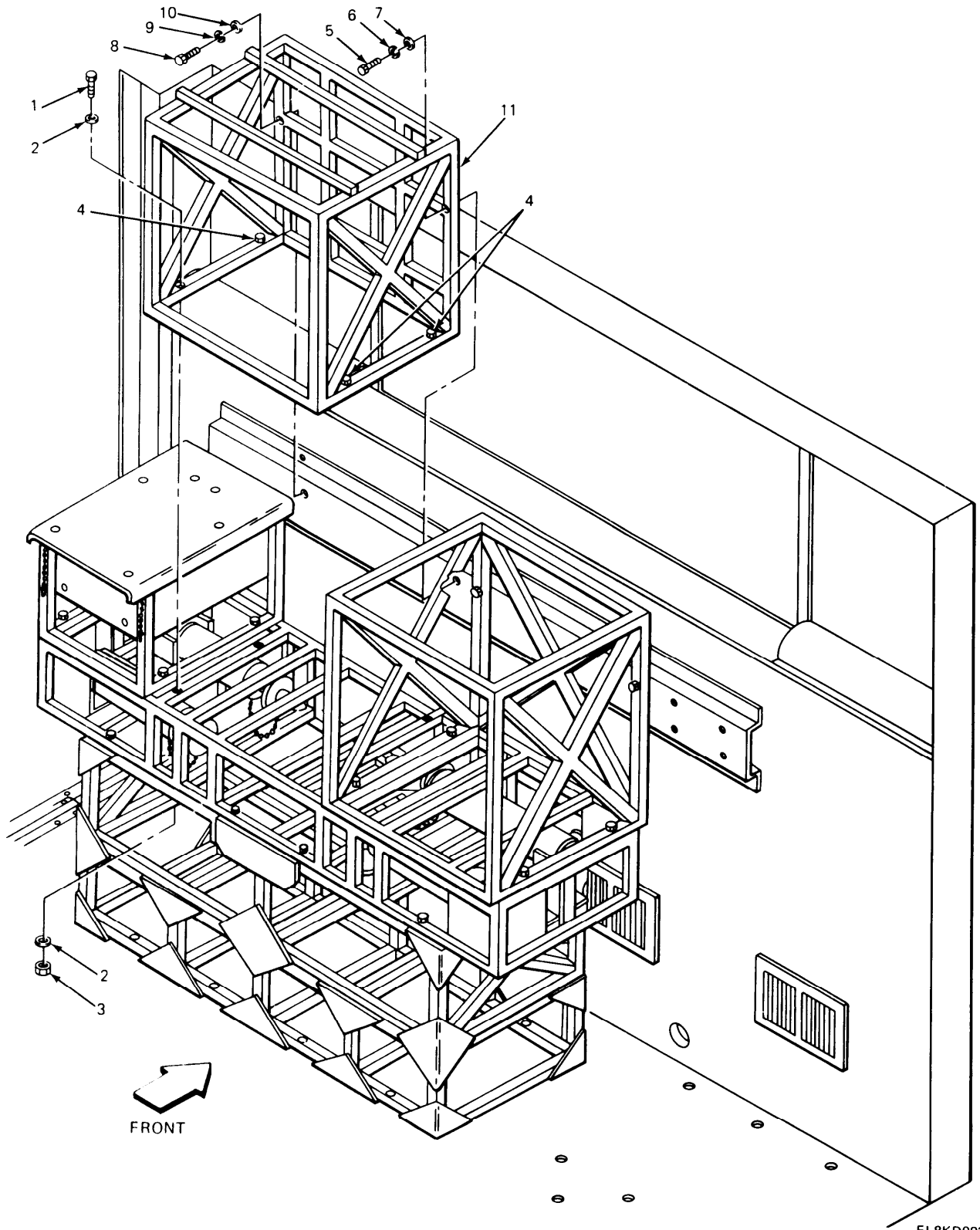

4-82. REMOVING/INSTALLING MESSAGE ENTRY GROUP RACK. (CONT)

LOCATION	ITEM	ACTION REMARKS
INSTALLATION		
1. Center position on electronic equipment table	Message entry group rack (1) and electronic equipment table (2)	Put message entry group rack on electronic equipment table and aline holes.
2. Lower supports on message entry group rack	Screw (3), flat washers (4) and nut (5)	Install, handtighten. There are four screws. Step 1 is typical for all four screws.
3.	Screws (6)	Do step 2 again.
4. Curbside, vertical support	Screw (7), lock-washer (8) and flat washer (9)	Install, handtighten.
6. Roadside, vertical support	Screw (10), lock-washer (11) and flat washer (10)	Install, handtighten.

NOTE

Using two 1/2-inch box wrenches, tighten all screws.

6. Lower supports	4-inch ground straps	See paragraph 4-11 for installation.
-------------------	----------------------	--------------------------------------

NOTE

See TM 11-7440-251-10 and TM 11-7440-253-10-1 for installation of message entry group

4-82. REMOVING/INSTALLING MESSAGE ENTRY GROUP RACK. (CONT)

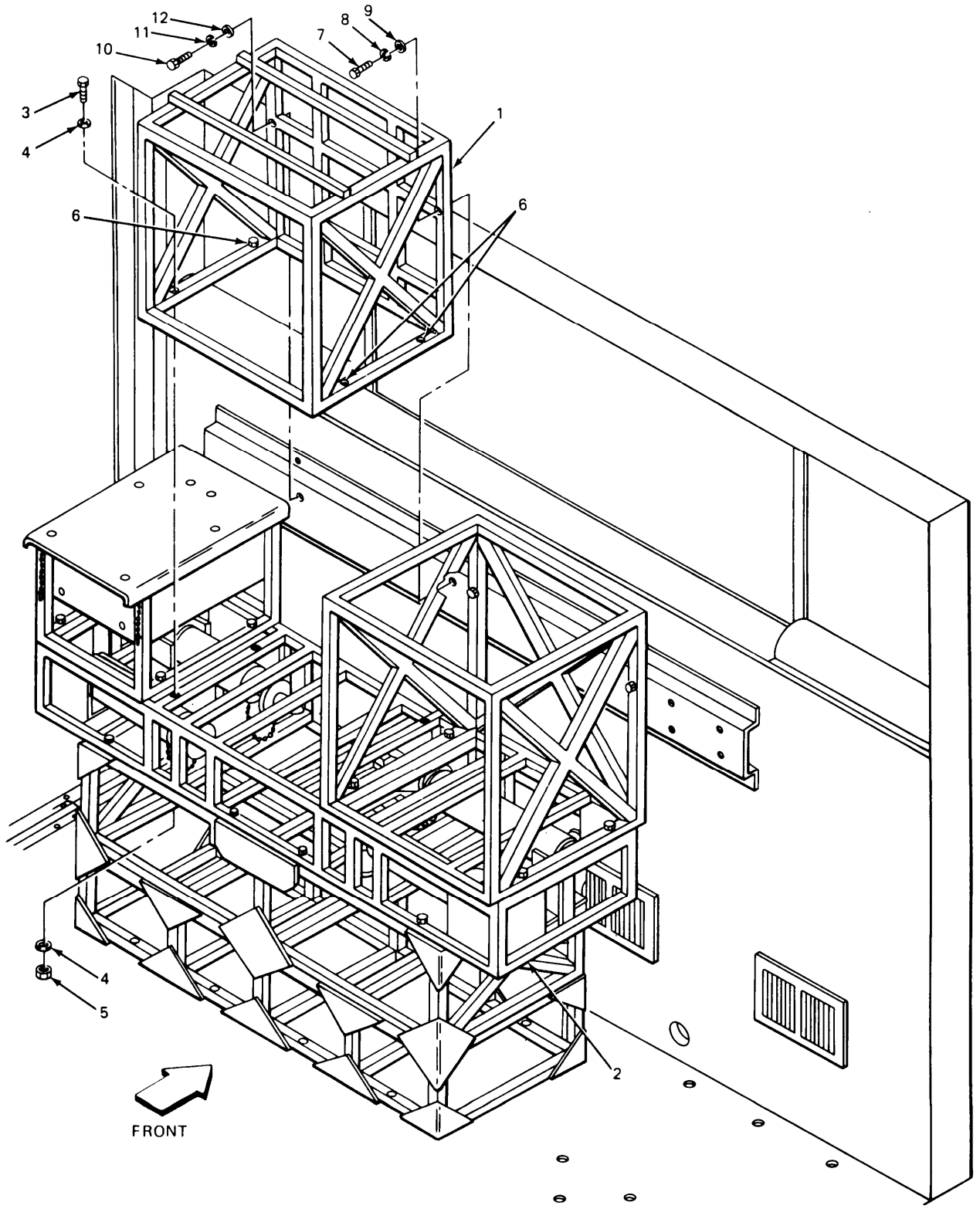

EL8KD093

4-83. REMOVING/INSTALLING KEY GENERATOR RACK.

This task covers:

1. Removal
2. Installation

INITIAL SETUP

Tools

1/2-inch box wrench (2 required)

Personnel Required

One mechanic

Materials/Parts

Key generator rack

Equipment Condition

All power in vehicle off.
 4-inch ground straps removed. (See paragraph 4-80.)
 30-inch grounding strap removed. (See paragraph 4-79.)

LOCATION	ITEM	ACTION REMARKS
----------	------	-------------------

REMOVAL

NOTE

See TM 11-7440-251-10 and TM 11-7440-253-10-1 for removal of key generator and power distribution box.

1. Lower supports of key generator rack	Screw (1), flat washer (2) and nut (3)	Using two 1/2-inch box wrenches, remove. There are four screws. Step 1 is typical for all four screws.
2.	Screws (4)	Do step 1 again.
3. Curbside, vertical support	Screw (5), lock-washer (6) and flat washer (7)	Using 1/2-inch box wrench, remove.
4. Roadside, vertical support	Screw (8), lock-washer (9) and flat washer (10)	Using 1/2-inch box wrench, remove.
5. Roadside, tacfire rack	Key generator rack (11)	Remove. For storage, put hardware in cloth bag, attach to key generator rack and pack in original carton.

4-83. REMOVING/INSTALLING KEY GENERATOR RACK. (CONT)

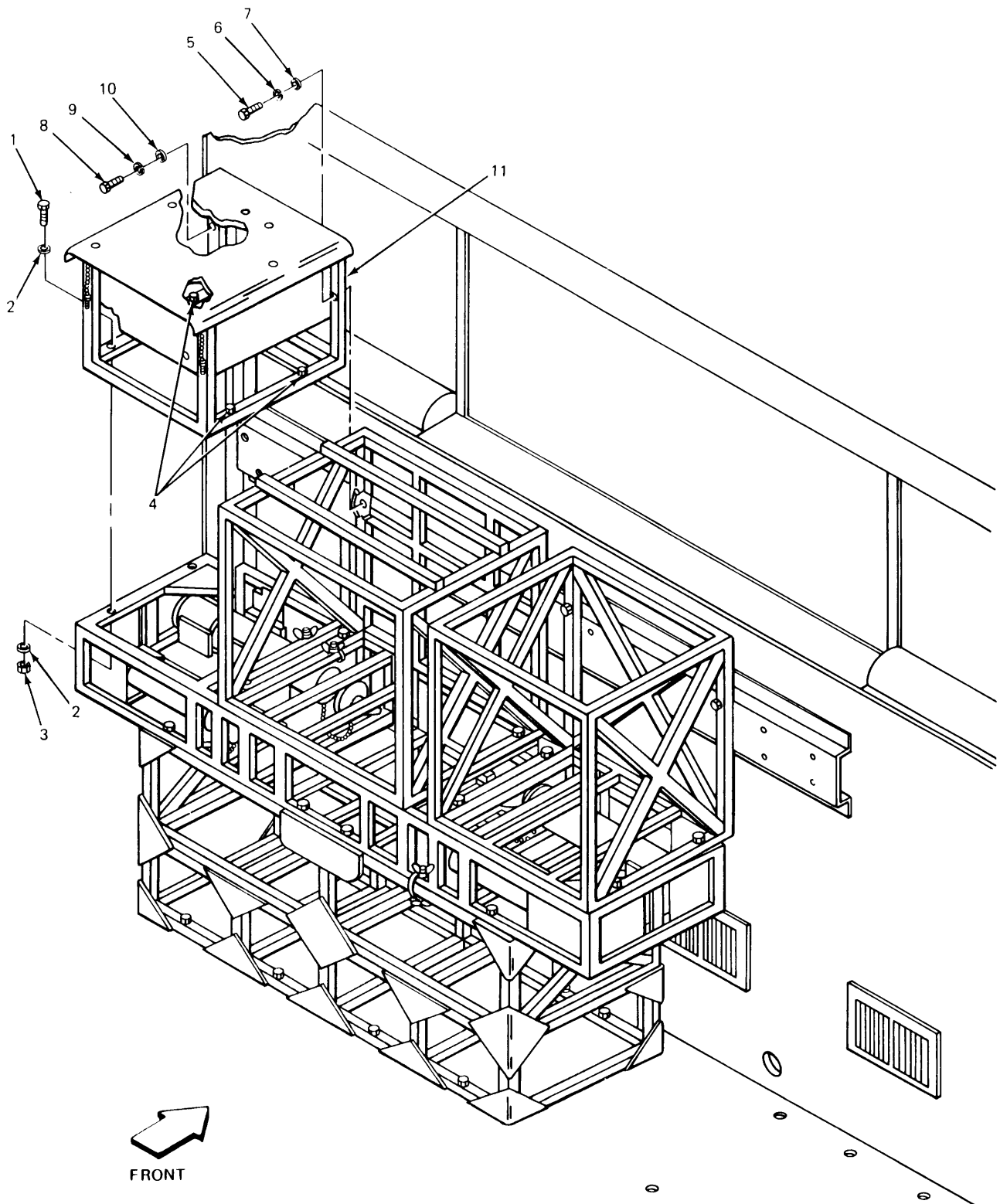

EL8KD094

4-83. REMOVING/INSTALLING KEY GENERATOR RACK. (CONT)

LOCATION	ITEM	ACTION REMARKS
INSTALLATION		
1. Roadside on top of electronic equipment table	Key generator rack (1) and electronic equipment table (2)	Put key generator rack on top of electronic equipment table and aline holes.
2. Lower supports on key generator rack	Screw (3), flat washers (4) and nut (5)	Install, handtighten. There are four screws. Step 2 is typical for all four screws.
3.	Screw holes (6)	Do step 2 again.
4.	Screw (7), lock-washer (8) and flat washer (9)	Install, handtighten.
5.	Screw (10), lock-washer (11) and flat washer (12)	Install, handtighten.

NOTE

Using two 1/2-inch box wrenches, tighten all screws.

6. Lower supports	4-inch ground straps	See paragraph 4-11 for installation.
-------------------	----------------------	--------------------------------------

NOTE

See TM 11-7440-251-10 and TM 11-7440-253-10-1 for installation of key generator and power distribution box. See paragraph 4-36 for installation of 30-inch grounding strap.

4-83. REMOVING/INSTALLING KEY GENERATOR RACK. (CONT)

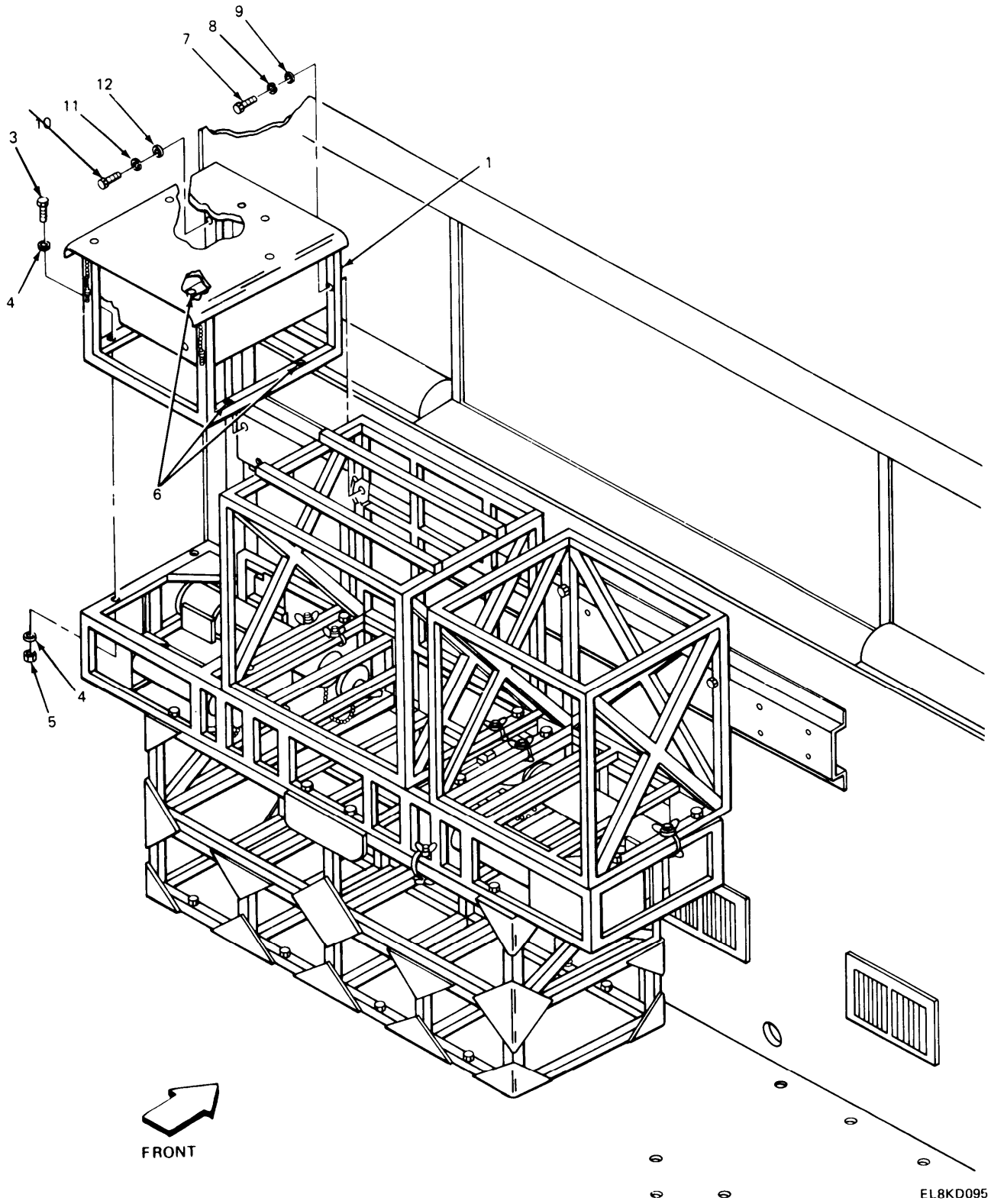

4-84. REMOVING/INSTALLING ELECTRONIC EQUIPMENT TABLE.

This task covers:

- 1. Removal
- 2. Installation

INITIAL SETUP

Tools

1/2-inch box wrench
(2 required)

Materials/Parts

Electronic equipment table

Personnel Required

Two mechanics

Equipment Condition

Electronic line printer rack removed. (See paragraph 4-81.)
Message entry group rack removed. (See paragraph 4-82.)
Key generator rack removed. (See paragraph 4-83.)

LOCATION	ITEM	ACTION REMARKS
----------	------	-------------------

REMOVAL

NOTE

Two mechanics are needed to lift electronic equipment table. See TM 11-7440-251-10 and TM 11-7440-253-10-1 for removal of tacfire components.

1. Top of radio mount	Screw (1), flat washers (2), and nut (3)	Using two 1/2-inch box wrenches, remove. There are eight screws. Step 1 is typical for all eight screws.
2.	Screws (4)	Do step 1 again.
3.	Electronic equipment table (5)	Remove. For storage, put hardware in cloth bag, attach to electronic equipment table and pack in original carton.

4-84. REMOVING/INSTALLING ELECTRONIC EQUIPMENT TABLE. (CONT)

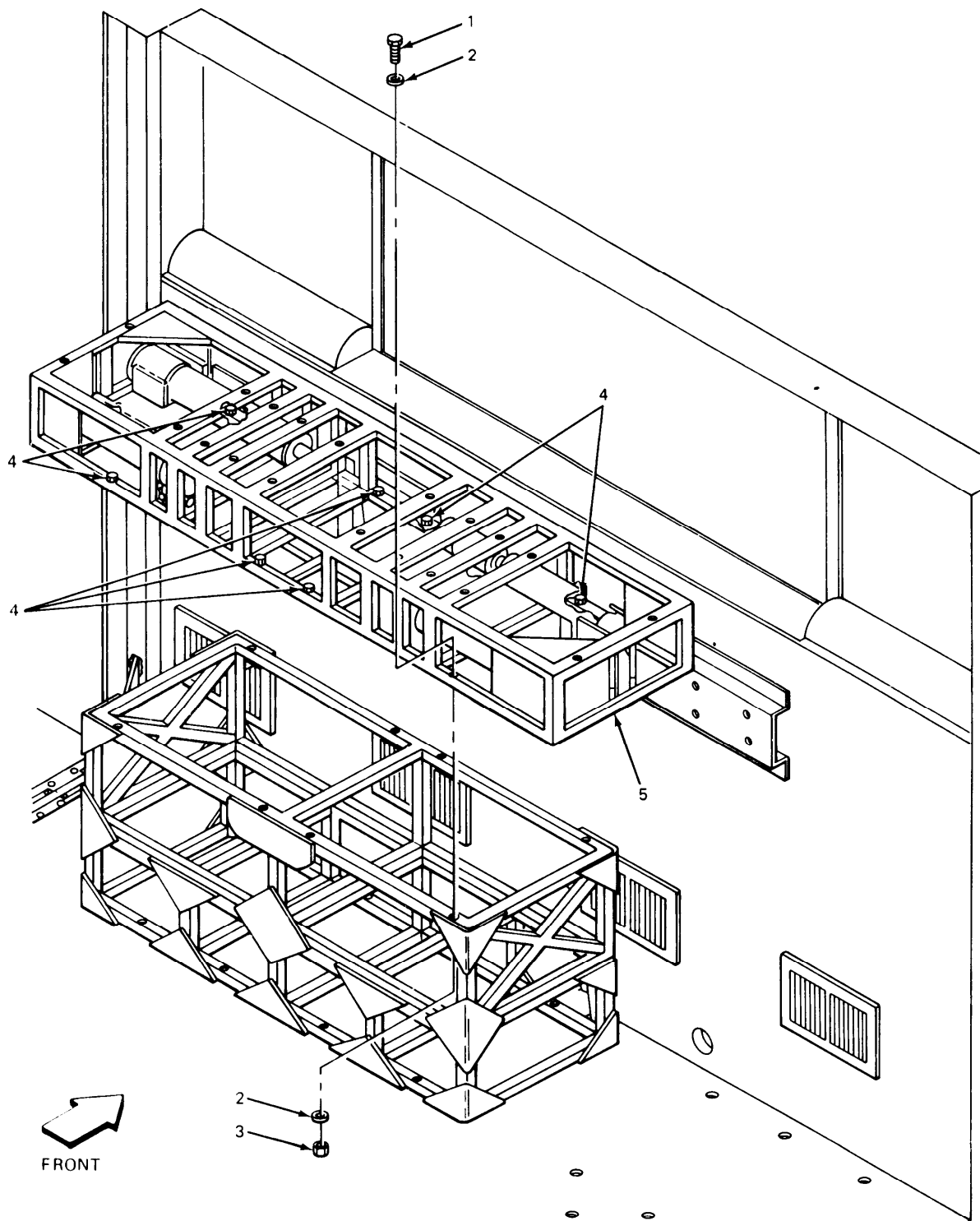

EL8KD096

4-84. REMOVING/INSTALLING ELECTRONIC EQUIPMENT TABLE. (CONT)

LOCATION	ITEM	ACTION REMARKS
INSTALLATION		
1.	Electronic equip- ment table (1) and radio mount (2)	Put electronic equipment table on radio mount and aline holes.
2.	Screw (3), flat washers (4) and nut (5)	Install, handtighten. There are eight screws. Step 2 is typical for all eight screws.
3.	Screw holes (6)	Do step 1 again.
4.	Screw (3) and nut (5)	Using two 1/2-inch box wrenches, tighten.. There are eight screws. Step 3 is typical for all eight screws.
5.	Screws (3) and nuts (5)	Do step 3 again.

NOTE

See paragraph 4-83 for installation of key generator rack.
See paragraph 4-82 for installation of message entry group
rack. See paragraph 4-61 for installation of electronic line
printer rack. See TM 11-7440-251-10 and TM 11-7440-253-10-1
for installation of tacfire components.

4-84. REMOVING/INSTALLING ELECTRONIC EQUIPMENT TABLE. (CONT)

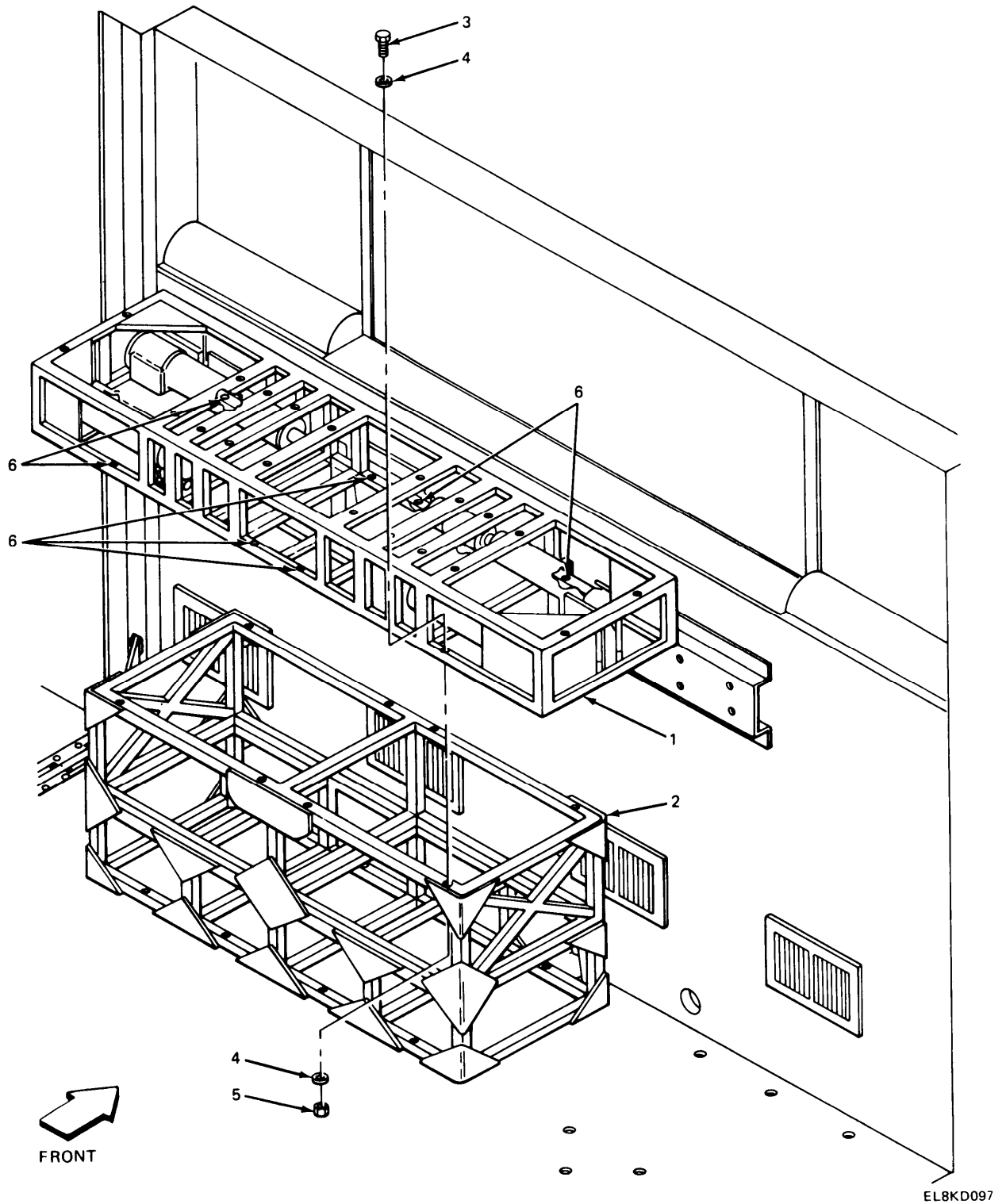

EL8KD097

4-85. REMOVING/INSTALLING RADIO MOUNT.

This task covers:

1. Removal
2. Installation

INITIAL SETUP

Tools	Personnel Required
1/2-inch box wrench	Two mechanics
Materials/Parts	Equipment Condition
Radio mount	Electronic equipment table removed. (See paragraph 4-84.)

LOCATION	ITEM	ACTION REMARKS
REMOVAL		
1. Base of radio mount	Screw (1), lock-washer (2) and flat washer (3)	Using 1/2-inch box wrench, remove. There are eight screws. Step 1 is typical for all eight screws.
2.	Screws (4)	Do step 1 again.
3.	Radio mount (5)	Remove. For storage, put hardware in cloth bag, attach to radio mount and pack in original carton.

INSTALLATION

1. Center position, next to forward wall	Radio mount (5)	Put in place and aline holes.
2.	Screw (1), lock-washer (2) and flat washer (3)	Install, handtighten. There are eight screws. Step 2 is typical for all eight screws.
3.	Screw holes (4)	Do step 2 again.

4-85. REMOVING/INSTALLING RADIO MOUNT. (CONT)

LOCATION	ITEM	ACTION REMARKS
INSTALLATION (CONT)		
4.	Screw (1)	Using 1/2-inch box wrench, tighten. There are eight screws. Step 4 is typical for all eight screws.
5.	Screws (1)	Do step 4 again.

NOTE

See paragraph 4-84 for installation of electronic equipment table.

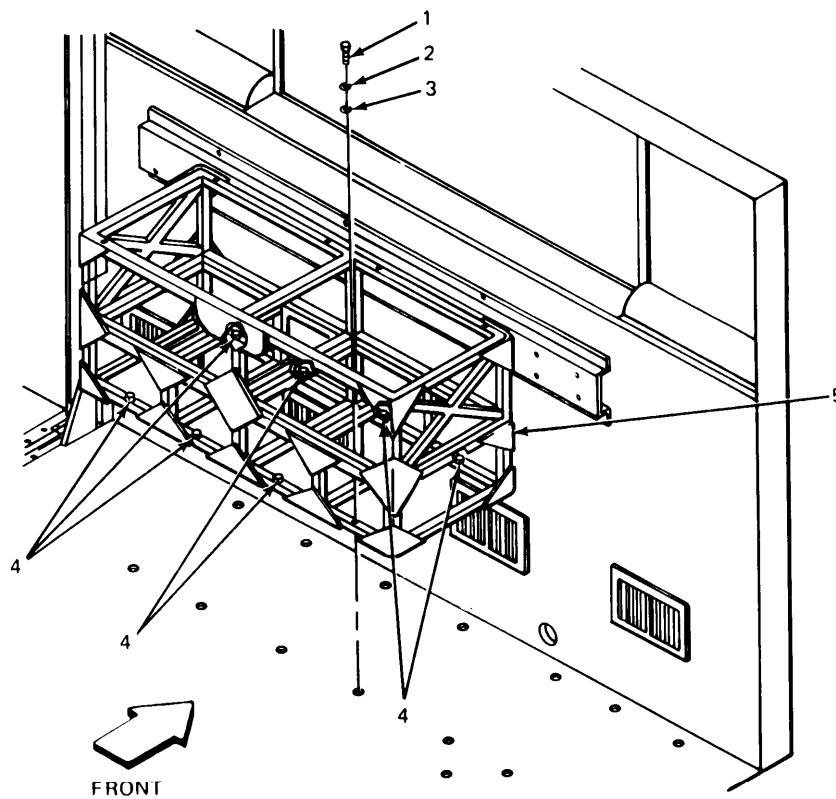

EL8KD098

4-86. REMOVING RADIO MOUNTING BASES MT-1029 /VRC.

This task covers:

Removal

INITIAL SETUP

Tools

1/2-inch box wrench

Personnel Required

One mechanic

Materials/Parts

Radio mounting bases 1029/VRC
(2 required)

Equipment Condition

Radio receiver transmitters
removed. (See paragraph 4-78.)

	LOCATION	ITEM	ACTION REMARKS
1.	Roadside, radio mount	Nut (1) and lockwasher (2)	Using 1/2-inch box wrench, remove. There are five nuts. Step 1 is typical for all five nuts.
2.	Mounting studs	Studs (3)	00 step 1 again.
3.		Radio mounting base MT-1029/VRC (4)	Remove.
4.	Curbside, radio mount	Radio mounting base MT-1029/VRC (5)	Do steps 1, 2 and 3 for second radio mounting base.
5.		Radio mounting bases MT-1029/VRC	See paragraph 4-31 for

4-86. REMOVING RADIO MOUNTING BASES MT-1029/VRC. (CONT)

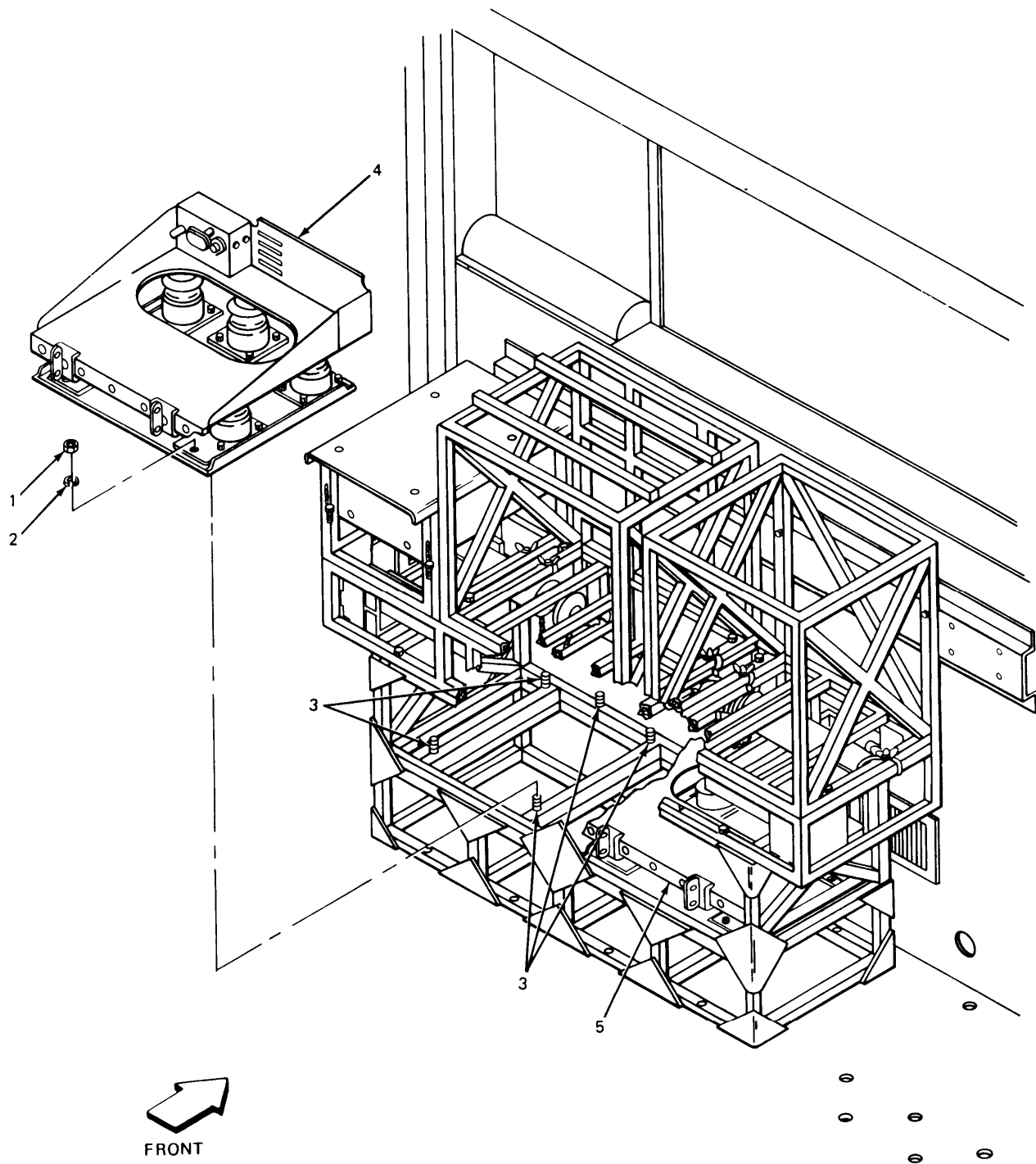

EL8KD099

4-87. REMOVING/INSTALLING WALL SUPPORT.

This task covers:

1. Removal
2. Installation

INITIAL SETUP

Tools	Equipment Condition
1/2-inch box wrench	Electronic line printer rack removed. (See paragraph 4-81.)
Materials/Parts	Message entry group rack removed. (See paragraph 4-80.)
Wall support	Key generator rack removed. (See paragraph 4-83.)
Personnel Required	DC/DC switch removed. (See paragraph 4-77.)
One mechanic	

LOCATION	ITEM	ACTION REMARKS
----------	------	-------------------

REMOVING

1. Wall support	Screw (1), lock-washer (2) and flat washer (3)	Using 1/2-inch box wrench, remove. There are six screws. Step 1 is typical for all six screws.
2.	Screws (4)	Do step 1 again.
3. Forward wall	Wall support (5)	Remove. For storage, put hardware in cloth bag, attach to wall support and pack in original carton.

INSTALLATION

1.	Wall support (5)	Put wall support in place and aline holes.
2.	Screw (1), lock-washer (2) and flat washer (3)	Install, handtighten. There are six screws. Step 2 is typical for all six screws.
3.	Screw holes (4)	Do step 2 again.

4-87. REMOVING/INSTALLING WALL SUPPORT. (CONT)

LOCATION	ITEM	ACTION REMARKS
INSTALLATION (CONT)		
4.	Screw (1)	Using 1/2-inch box wrench, tighten. There are six screws. Step 4 is typical for all six screws.
5.	Screws (1)	Do step 4 again.

NOTE

See paragraph 4-77 for installation of DC/DC switch. See paragraph 4-81 for installation of electronic line printer rack. See paragraph 4-82 for installation of message entry group rack. See paragraph 4-83 for installation of key generator rack.

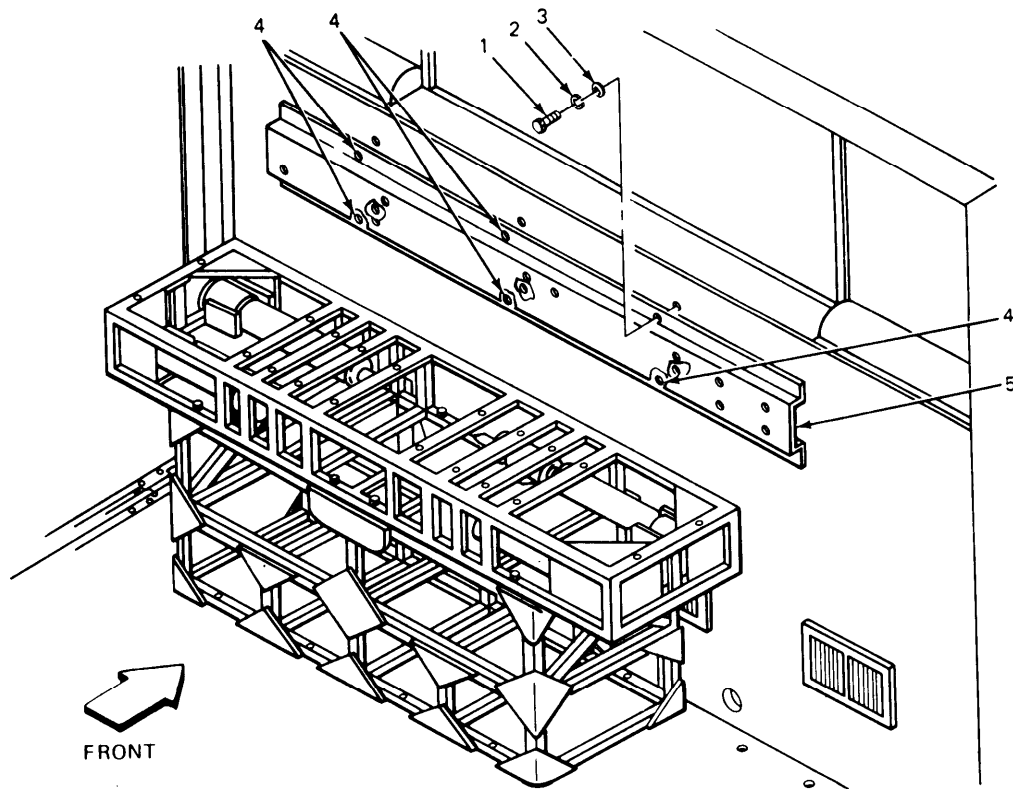

4-88. REMOVING CURBSIDE OR ROADSIDE ANTENNA CABLES.

This task covers:

Removal

INITIAL SETUP

Tools

Flat-tip screwdriver

Materials/parts

Cable Assembly CX-4722/VRC
 Cable Assembly CX-1773B/U

Personnel Required

One mechanic

Equipment Condition

Antenna cables disconnected.
 See SB 11-131 for removal.

LOCATION	ITEM	ACTION REMARKS
----------	------	-------------------

NOTE

See SB 11-131 for removal of antenna cables from radio receiver transmitter and antenna mount.

1. Curbside	Nylon ties (1)	Remove.
2. Curbside, under door	Screws (2) and cable clamps (3)	Using flat-tip screwdriver, remove.
3. Curbside	Antenna cables (4)	Remove. For storage, put hardware in cloth bag, attach to antenna cables and pack in original cartons.

NOTE

Curbside and roadside antenna cables are the same. Location of nylon ties and direction of routing cables is different, method of removing cables is same. See paragraphs 4-40 and 4-41 for routing and installation of curbside antenna cables. See paragraphs 4-45 and 4-46 for routing and installation of roadside antenna cables.

4-88. REMOVING CURBSIDE OR ROADSIDE ANTENNA CABLES. (CONT)

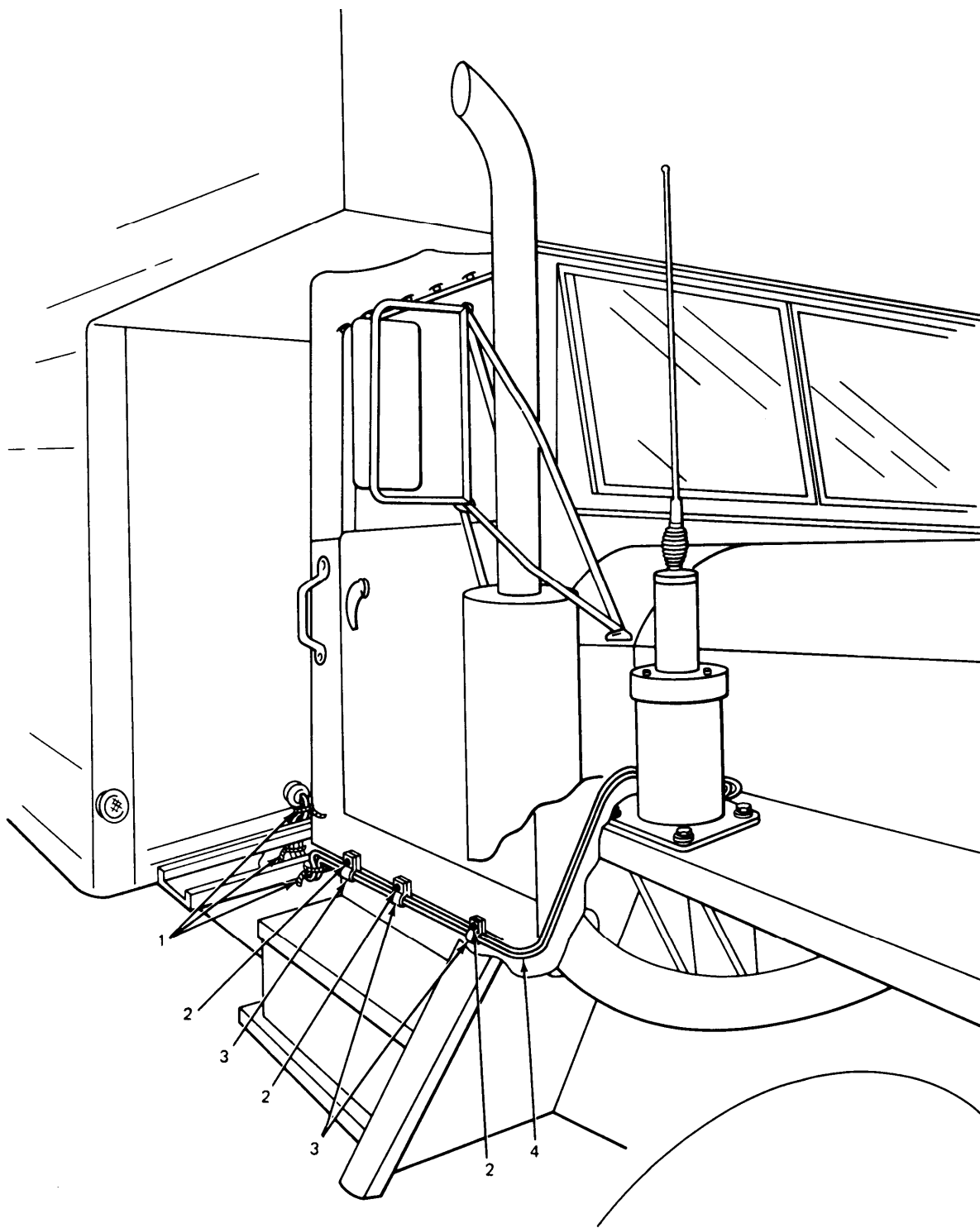

EL8KD101

4-89. REMOVING ANTENNA MASTS.

This task covers:

Removal

INITIAL SETUP

Tools

Adjustable crescent wrench
1/8-inch hex wrench

Materials/Parts

Antenna mast (2 required)

Personnel Required

One mechanic

Equipment Condition

Radio receiver transmitter off.

LOCATION	ITEM	ACTION REMARKS
1.	Antenna mast (1)	Using adjustable wrench, remove. For storage, put hardware in cloth bag, attach to antenna masts and store in original carton.
NOTE		
Curbside and roadside antenna masts are the same. Repeat step 1 for roadside antenna mast.		
2.	Antenna mast (1)	See paragraph 4-47 for installation.
NOTE		
Curbside and roadside antenna masts are the same. Repeat step 1 for roadside antenna mast.		

4-89. REMOVING ANTENNA MASTS. (CONT)

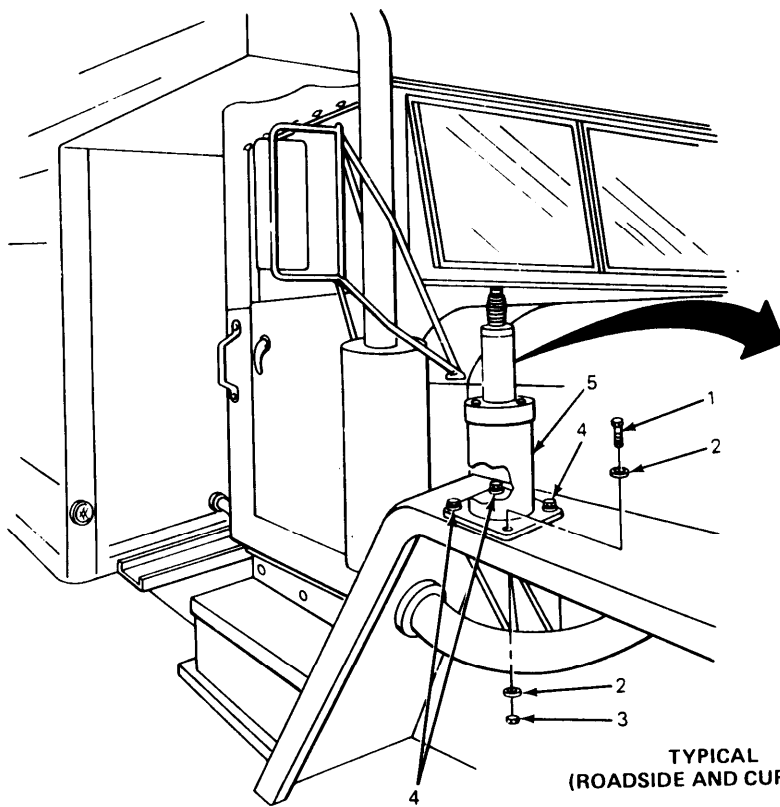

TYPICAL
(ROADSIDE AND CURBSIDE)

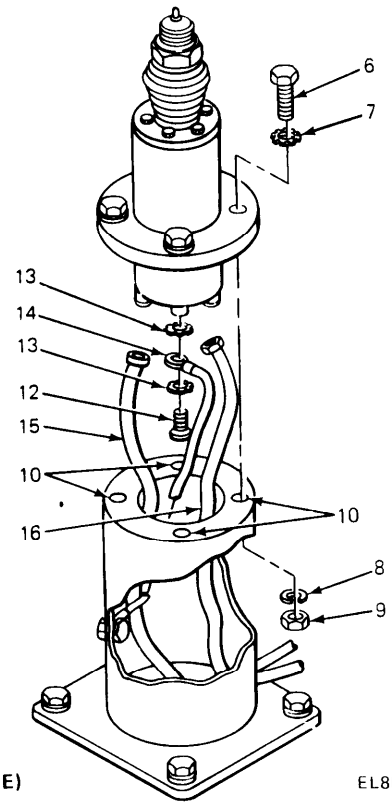

EL8KD102

4-90. REMOVING CURBSIDE OR ROADSIDE ANTENNA MOUNT ASSEMBLIES.

This task covers:

Removal

INITIAL SETUP

Tools

- 9/16-inch box wrench
(2 required)
- 3/8-inch box wrench

Personnel Required

One mechanic

Equipment Condition

Materials/parts

- Antenna Assembly AS-1729/VRC
- Antenna mount

Antenna cables removed. (See paragraph 4-88.)
Antenna mast removed. (See paragraph 4-89.)

LOCATION	ITEM	ACTION REMARKS
1. Curbside antenna mount	Screw (1), flat washers (2) and nut (3)	Using two 9/16-inch box wrenches, remove. There are four screws. Step 1 is typical for all four screws.
2.	Screws (4)	Do step 1 again.
3. Curbside	Antenna mount assembly (5)	Lift away.
4. Antenna mount	Screw (6), IET lockwasher (7), lockwasher (8) and nut (9)	Using 9/16-inch box wrench, 9/16-inch socket extension and ratchet, remove. There are four screws. Step 3 is typical for all four screws.
5.	Screws (10)	Do step 3 again.
6.	Antenna assembly (11)	Lift away.
7. Antenna Assembly AS-1729/VRC	Screw (12), IET lockwashers (13) and bonding jumper (14)	Using 3/8-inch box wrench, remove.
8.	Cable assembly rf (15) and cable assembly sp (16)	Disconnect.

4-90. REMOVING CURBSIDE OR ROADSIDE ANTENNA MOUNT ASSEMBLIES. (CONT)

LOCATION	ITEM	ACTION REMARKS
9. Antenna mount	Cable assembly rf (15) and cable assembly Sp (16)	Remove.
10.	Antenna mount (5) and antenna assembly (11)	Remove. For storage, put hardware in cloth bag. Attach to antenna mount and pack in original carton.

NOTE

Curbside and roadside antenna mounts are the same. Method of removing is the same. See paragraphs 4-37 and 4-42 for installation of curbside and roadside antenna mounts.

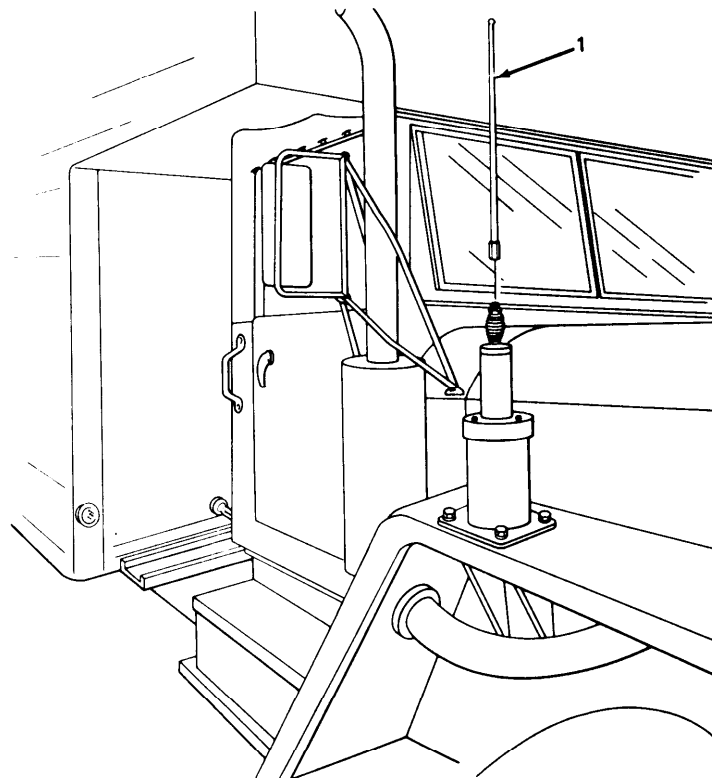

EL8KD103

4-91. REMOVING EXTERNAL GROUNDING ROD.

This task covers:

Removal

INITIAL SETUP

Tools

Flat-tip screwdriver
 8-pound sledge hammer
 Pliers

Personnel Required

One mechanic

Equipment Condition

Materials/Parts

Ground rod installed.

None

LOCATION	ITEM	ACTION REMARKS
1. Roadside, lower gusset	Wingnut (1), IT lockwasher (2) and 10-foot grounding strap (3)	Using pliers, remove.
2.	IT lockwasher (2) and wingnut (1)	Using pliers, install.
3. Grounding rod	Screws (4) and ground rod clamp (5)	Using flat tip screwdriver, loosen.
4. Outside of vehicle	Grounding rod (6)	Using 8-pound sledge hammer, remove. Hit grounding rod from side to side. Pour water over grounding rod to soften ground. Continue to hit and pour water over grounding rod until it can be pulled from ground.

NOTE

The grounding rod comes in three sections. Uncouple three sections and place in canvas bag with 10-foot ground strap and ground rod clamp. Store under radio mount. See paragraph 4-63 for installation of external ground rod kit.

4-91. REMOVING EXTERNAL GROUNDING ROD. (CONT)

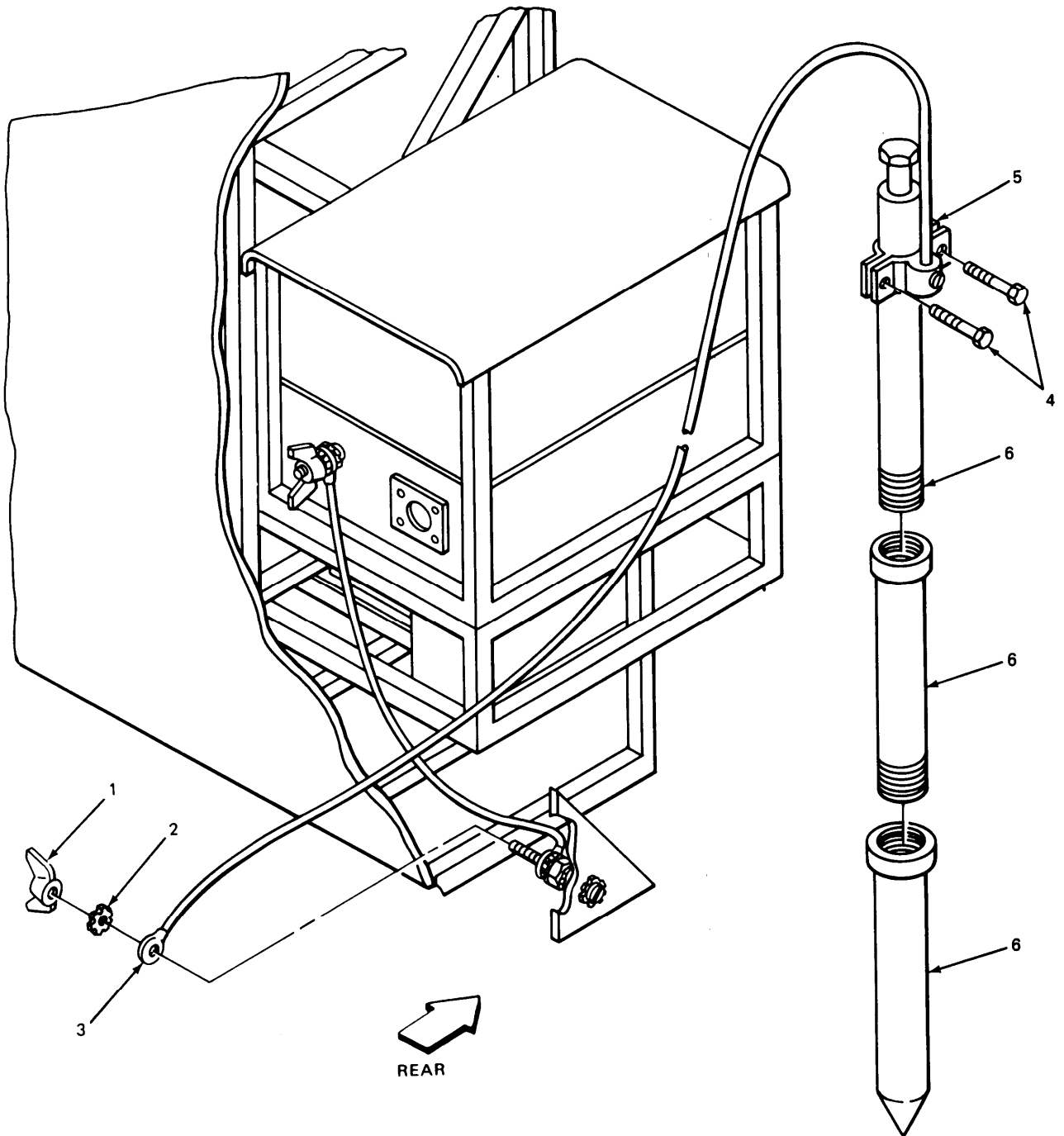

EL8KD104

Section VIII PREPARATION FOR STORAGE AND SHIPMENT

Refer to SB 38-100 for preservation, packaging, packing and marking materials, supplies, and equipment used by the Army.

CHAPTER 5

DIRECT SUPPORT AND GENERAL SUPPORT MAINTENANCE

There are no direct support and general support maintenance procedures required for Electronic Equipment Installation Kit, MK-1818/GSG-10(V) in truck, van (expansive) 5-ton, M820.

APPENDIX A

REFERENCES

A-1. SCOPE.

The following publications contain information applicable to the installation of Electronics Equipment Installation Kit MK-1818/GSG-10(V) in truck, van (expandable), 5-ton, M820.

A-2. PAMPHLETS.

Consolidated index of Army Publications and Blank Forms	DA Pam 310-1
Report of Packaging and Handling Deficiencies	AR 700-58

A-3. SUPPLY BULLETINS.

Vehicular Radio Sets and Authorized Installations	SB 11-131
Painting and Preservation Supplies Available for Field Use for Electronics Command Equipment	SB 11-573
Preservation, Packaging, Packing and Marking Materials, Supplies, and Equipment Used by the Army	SB 38-100

A-4. TECHNICAL BULLETINS.

Field Instructions for Painting and Preserving Electronics Command Equipment, Including Camouflage Pattern Painting of Electrical Equipment Shelters	TB 43-0118
Safety Measures to be Observed when Installing and Using Whip Antennas, Field Type Masts, Towers, Antennas, and Metal Poles that are used with Communication, Radar and Direction Finder Equipment	TB SIG 291

A-5. TECHNICAL MANUALS.

Operator's Manual: Data Display, Artillery, Battery, AN/GSQ-122 (BDU) (NSN 7010-01 -017-3741)	TM 11-7440-251-10
Operator's Manual: Message Entry Device, Variable Format, AN/GSC-21 (VFMED) (NSN 7010-01-017-6967)	TM11-7440-253-101

A-5. TECHNICAL MANUALS. (CONT)

The Army Maintenance Management System (TAMMS)	TM 38-750
Administrative Storage of Equipment	TM 740-90-1
Procedures for Destruction of Electronics Materiel to Prevent Enemy Use (Electronics Command)	TM 750-244-2

APPENDIX B

MAINTENANCE ALLOCATION CHART

Section I INTRODUCTION

B-1. SCOPE.

a. This section provides a general explanation of all maintenance and repair functions authorized at various maintenance categories.

b. The Maintenance Allocation Chart (MAC) in section II designates overall authority and responsibility for the performance of maintenance functions on the identified end item or component. The application of the maintenance functions to the end item or component will be consistent with the capacities and capabilities of the designated maintenance categories.

c. Section III lists the tools and test equipment (both special tools and common tool sets) required for each maintenance function as referenced from section II.

d. Section IV contains supplemental instructions and explanatory notes for a particular maintenance function.

B-2. MAINTENANCE FUNCTIONS.

Maintenance functions will be limited to and defined as follows:

a. Inspect. To determine the serviceability of an item by comparing its physical, mechanical, and/or electrical characteristics, with established standards through examination (e.g., by sight, sound, or feel.)

b. Test. To verify serviceability by measuring the mechanical, pneumatic, hydraulic, or electrical characteristics of an item and comparing those characteristics with prescribed standards.

c. Service. Operations required periodically to keep an item in proper operating condition, i.e., to clean (includes decontaminate, when required), to preserve, to drain, to paint, or to replenish fuel, lubricants, chemical fluids, or gases.

d. Adjust. To maintain or regulate, within prescribed limits, by bringing into proper or exact position, or by setting the operating characteristics to specified parameters.

e. Aline. To adjust specified variable elements of an item to bring about optimum or desired performance.

f. Calibrate. To determine and cause corrections to be made or to be adjusted on instrument or test, measuring and diagnostic equipment used in precision measurement. Consists of comparisons of two instruments, one of which is a certified standard of known accuracy, to detect and adjust any discrepancy in the accuracy of the instrument being compared.

B-2. MAINTENANCE FUNCTIONS. (CONT)

g. Remove/Install. To remove and install the same item when required to perform service or other maintenance functions. Install may be the act of emplacing, seating, or fixing into position a spare, repair part, or module (component or assembly) in a marine; to allow the proper functioning of a piece of equipment or system.

h. Replace. To remove an unserviceable item and install a serviceable counterpart in its place. 'Replace' is authorized by the MAC and is shown as the 3rd position code of the SMR code.

i. Repair. The application of maintenance services, including fault location/troubleshooting, removal/ installation, and disassembly/assembly procedures, and maintenance actions to identify troubles and restore serviceability to an item by correcting specific damage, fault, malfunction, or failure in a part, subassembly, module (component or assembly), end item or system.

j. Overhaul. That maintenance effort (service or action) prescribed to restore an item to a completely serviceable/operational condition as required by maintenance standards in appropriate technical publications (i.e., DMWR). Overhaul is normally the highest degree of maintenance performed by the Army. Overhaul does not normally return an item to like new condition.

k. Rebuild. Consists of those services/actions necessary for the restoration of unserviceable equipment to a like new condition in accordance with original manufacturing standards. Rebuild is the highest degree of materiel maintenance applied to Army equipment. The rebuild operation includes the act of returning to zero those age measurements (hours/miles, etc) considered in classifying Army equipment/components.

B-3. EXPLANATION OF COLUMNS IN THE MAC, SECTION II.

a. Column 1, Group Number. Column 1 lists functional group code numbers, the purpose of which is to identify maintenance significant components, assemblies, subassemblies, and modules with the next higher assembly. End item group number shall be '00'.

b. Column 2, Component/Assembly. Column 2 contains the names of components, assemblies, subassemblies, and modules for which maintenance is authorized.

c. Column 3, Maintenance Function. Column 3 lists the functions to be performed on the item listed in column 2. For detailed explanation of these functions, see paragraph B-2.

B-3. EXPLANATION OF COLUMNS IN THE MAC, SECTION II. (CONT)

d. Column 4, Maintenance Category. Column 4 specifies, by the listing of a work time figure in the appropriate subcolumn(s), the category of maintenance authorized to perform the function listed in column 3. This figure represents the active time required to perform that maintenance function at the indicated category of maintenance. If the number or complexity of the tasks within the listed maintenance function vary at different maintenance categories, appropriate work time figures will be shown for each category. The work time figure represents the average time required to restore an item (assembly, subassembly, component, module, end item, or system) to a serviceable condition under typical field operating conditions. This time includes preparation time (including any necessary disassembly/assembly time), troubleshooting/fault location time, and quality assurance/quality control time in addition to the time required to perform the specific tasks identified for the maintenance functions authorized in the maintenance allocation chart. The symbol designations for the various maintenance categories are as follows:

C - Operator or Crew

O - Organizational Maintenance

F - Direct Support Maintenance

H - General Support Maintenance

D - Depot Maintenance

e. Column 5, Tools and Equipment. Column 5 specifies, by code, those common tool sets (not individual tools) and special tools, TM DE, and support equipment required to perform the designated function.

f. Column 6, Remarks. This column shall, when applicable contain a letter code, in alphabetical order, which shall be keyed to the remarks contained in section IV.

B-4. EXPLANATION OF COLUMNS IN TOOL AND TEST EQUIPMENT REQUIREMENTS, SECTION III.

a. Column 1, Reference Code. The tool and test equipment reference code correlates with a code used in the MAC, section 11, column 5.

b. Column 2, Maintenance Category. The lowest category of maintenance authorized to use the tool or test equipment.

c. Column 3, Nomenclature. Name or identification of the tool or test equipment.

d. Column 4, National Stock Number. The national stock number of the tool or test equipment.

e. Column 5, Tool Number. The manufacturer's part number.

B-5. EXPLANATION OF COLUMNS IN REMARKS, SECTION IV.

a. Column 1, Reference Code. The code recorded in column 6, section II.

b. Column 2, Remarks. This column lists information pertinent to the maintenance function being performed as indicated in the MAC, section III.

**Section II. MAINTENANCE ALLOCATION CHART FOR ELECTRONICS EQUIPMENT
INSTALLATION KIT MK-1818/GSG-10(V)**

(1) GROUP NUMBER	(2) COMPONENT/ ASSEMBLY	(3) MAINTENANCE FUNCTION	(4) MAINTENANCE CATEGORY					(5) TOOLS AND EQPT	(6) REMARKS
			C	O	F	H	D		
00	Installation Kit MK 1818/ GSG-10(V)	Install		10.5				1,2	
01	Tacfire rack	Inspect Service Replace Repair	0.3 0.3	0.1	1.5			1,2	A,D
0101	Radio Mount	Inspect Service Replace Repair	0.1 0.2	2.0	2.75			1,2,5	A
0102	Table Mount	Inspect Service Replace Repair	0.1 0.2	1.5	2.0			1,2	A
0103	Key Generator Rack	Inspect Service Replace Repair	0.1 0.2	0.5	0.75			1,2	A
0104	Message Entry Group Rack	Inspect Service Replace Repair	0.1 0.2	0.5	0.75			1,2	A
0105	Electronic Line Printer Rack	Inspect Service Replace Repair	0.1 0.2	0.5	0.75			1,2	A

**Section II. MAINTENANCE ALLOCATION CHART FOR ELECTRONICS EQUIPMENT
INSTALLATION KIT MK-1818/GSG-10(V)**

(1) GROUP NUMBER	(2) COMPONENT/ ASSEMBLY	(3) MAINTENANCE FUNCTION	(4) MAINTENANCE CATEGORY					(5) TOOLS AND EQPT	(6) REMARKS
			C	O	F	H	D		
0106	Wall Support	Inspect Service Replace Repair	0.1 0.2	0.4	0.5			1,2,5	A
02	Tacfire Components								E,F
0201	Electronic Line Printer								E,F
0202	Message Entry Group								E,F
0203	Key Generator								B,E, F
0204	Radio Receiver Transmitter								C
03	DC/DC Switch	Inspect Service Replace Repair	0.1 0.2	0.5	1.0			1,2	A
04	Antenna Assemblies	Inspect Service Replace Repair	0.25 0.25	1.0	1.5			1,2	A
05	Power Supply	Inspect Service Replace Repair	0.1 0.2	1.0	2.0			1,2,5	A

**Section III. TOOLS AND TEST EQUIPMENT REQUIREMENTS FOR ELECTRONICS
EQUIPMENT INSTALLATION KIT MK-1818/GSG-10(V)**

TOOLS OR TEST EQUIPMENT REF CODE	MAINTENANCE CATEGORY	NOMENCLATURE	NATIONAL/NATO STOCK NUMBER	TOOL NUMBER
1	C,O,F,H	Tool Kit, Mechanic	5180-00-754-0641	
2	C,O,F,H	No. 2 Common Organi- zational Maintenance Tool Kit	591 0-00-754-0654	
3	C,O	Methyl Ethyl Ketone	6810-00-264-8983	
4	C,O	Cleaning Cloth		
5	C,O,F,H	Rivnut Tool		

Section IV REMARKS

REFERENCE CODE	REMARKS
A	Preventive maintenance
B	See KAM-240B/TSEC Vol. I
C	See TM 11-5820-401-12
D	See TB 43-0118
E	See TM 11-7440-251-10
F	See TM 11-7440-253-10-1

GLOSSARY

A collection of words or terms and their definitions are given in this section.

Aline	Arrange or bring into line.
Alternating Current (ac)	An electric current that reverses its direction at regularly recurring intervals.
Clockwise	Moving in the direction traveled by the hands of a clock. (Right)
Counterclockwise	Opposite the direction of the hands traveled by a clock. (Left)
Crimp	To bend into shape, to fasten.
Direct Current (dc)	An electric current flowing in one direction only and substantially constant in value.
Engaged	To apply, to make connection with.
Expansible	Capable of being expanded.
External	Outside of subject.
Flush	Up against.
Gusset	A reinforcing plate.
Hardware	Manufactured articles of metal, like lockwashers, flat washers, nuts bolts.
Install	To put in place or position.
Pilot drill	To make ready for final drilling.
Preparation	To make ready.

GLOSSARY (CONT)

Route	To put in place on a specific path or course.
Stud	A headless screw.
Terminal Lug	A device attached to the end of a wire or cable to make an electrical connection.
Ventilate	To expose to air.
Visibility	To be seen.

INDEX

Subject	Page
A	
Abbreviations, list of	1-4
Administrative storage	1-2
Angle brackets, PP-1104, installation	4-18
removal	4-124
PP-4763, installation	4-20
removal	4-128
Antenna masts, installation	4-88
removal	4-188
Assembly, tacfire rack	4-6
electronic equipment table to radio mount	4-6
electronic line printer rack to electronic equipment table	4-12
key generator rack to electronic equipment table	4-8
message entry group to electronic equipment table	4-10
wall support to electronic equipment racks	4-14
Assembly and installation of electronic equipment kit	4-4

C

Cables, curbside antenna	4-76
dc/dc switch routing	4-64
power cable (26-foot)	4-94
power supply power cable	4-108
roadside antenna	4-86
Cable connector, 90°	4-92
Cable connector to power supply outlet box	4-106
Cable connector to 4 x 4-inch outlet box	4-102
Checking unpacked materiel	4-4
Circuit breaker, installation	4-92
removal	4-150
Common tools and equipment	B-1
Curbside antenna mount assembly, installation	4-72
removal	4-190

D

DC/DC switch, installation	4-62
---	------

INDEX (CONT)

Subject	Page
D (CONT)	
removal	4-156
routing of de/de switch cables	4-64
Description and use of operator's controls and indicators	2-1
Destruction of army electronic materiel to prevent enemy use	1-2
Drilling instructions,	
cable connector, 90°	4-48
for flush mounting of rivnuts	4-46
ground straphole	4-44
pilot drilling	4-40
pipe nipple	4-44
rivnut holes.	4-44
E	
Electronics equipment table,	
installation	4-6
removal	4-162
Electronic line printer rack,	
installation	4-56
removal	4-164
Equipment,	
capabilities and features	1-5
location and description of major components,	1-6
purpose	1-5
safety, care and handling	1-8
Equipment capabilities and features	1-5
Equipment description	1-5
External grounding rod,	
installation	4-118
removal	4-190
G	
General information.	1-1
Ground strap,	
4-inch,	
installation	4-16
removal	4-162
30-inch,	
installation	4-66
removal	4-160
Guard assembly,	
installation	4-116
removal	4-122

INDEX (CONT)

Subject	Page
H	
How to use the manual	ii
Hubbell connector plug, installation	4-104
removal	4-136
I	
Installation, angle brackets, PP-1104	4-18
angle bracket, PP-4763	4-20
antenna masts	4-88
antenna assembly AS-1729/VRC to antenna mount	4-68
cable connector to 4 x 4-inch outlet box	4-100
cable connector to power supply	4-108
cable connector, 90°, to circuit breaker box	4-92
circuit breaker, 30 amp	4-92
curbside antenna cable	4-76
curbside antenna mount	4-72
dc/dc switch	4-64
electronic equipment table	4-6
electronic line printer rack	4-12
external grounding rod	4-118
face plate	4-102
ground strap to gusset	4-66
ground strap to power distribution box	4-66
guard assembly	4-116
Hubbell connector plug	4-104
key generator rack	4-8
message entry group rack	4-10
pipe nipple	4-54
powercable	4-94
power cable, 6-foot, to circuit breaker box	4-94
power cable to power supply	4-98
powercable, 26-foot, to 4 x 4-inch outlet box	4-102
power supply, PP-1104	4-110
power supply, PP-4763	4-112
power supply cable from dc/dc switch to power supply	4-114
radio mount	4-6
radio mounting bases MT-1029/VRC	4-58
receptacle	4-102
roadside antenna cable	4-86
roadside antenna mount	4-82
rivnuts	4-50
tacfire components	4-60
tacfire rack	4-6
wall support	4-14
4 x 4-inch outlet box	4-100
Introduction	1-1

INDEX (CONT)

Subject	Page
K	
Key generator rack, installation	4-8
removal	4-172
L	
Location and description of major components	1-4
M	
Maintenance, maintenance forms, records, and reports	1-2
reports of maintenance and unsatisfactory equipment	1-1
reports of packaging and handling deficiencies	1-1
Maintenance allocation chart	B-1
Maintenance forms, records, and reports	1-1
Maintenance procedures	3-1
Message entry group rack, installation	4-10
removal	4-168
N	
Nomenclature cross-reference	1-2
O	
Operating instructions	2-1
Operator maintenance	3-1
Operator preventive maintenance checks and services	2-1
Organizational maintenance	4-120
Organizational troubleshooting	4-120
Outlet box, 4 x 4-inch, installation	4-100
removal	4-142
P	
Pilot drilling	4-40
Pipe nipple, installation	4-54
removal	4-154

INDEX (CONT)

Subject	Page
P (CONT)	
Power cable, 26-foot,	
installation	4-94
removal	4-144
routing	4-144
Power supply,	
PP-1104,	
installation	4-110
removal	4-130
PP-4763,	
installation	4-112
removal	4-134
Preparing for drilling,	
cable connector, 90°, mounting hole.	4-30
curbside antenna cable mounting holes.	4-32
ground strap mounting hole	4-28
pipe nipple mounting hole,	4-28
power supply and guard assembly mounting holes	4-24
roadside antenna cable mounting holes.	4-34
tacfire rack mounting holes	4-20
Preparation for storage and shipment	4-120
Preventive maintenance checks and services	4-120
Principles of operation	1-6
Purpose of installation kit	1-4

R

Radio mount,	
installation	4-180
removal	4-180

INDEX (CONT)

Subject	Page
R (CONT)	
Radio mounting bases 1029/VRC, installation	4-58
removal	4-182
References	A-1
Removal, angle brackets, PP-1104	4-124
angle brackets, PP-4763	4-128
antenna masts	4-188
cable connector from 4 x 4-inch outlet box.	4-142
cable connector from power supply	4-138
cable connector, 90°, from circuit breaker box	4-150
circuit breaker, 30 amp	4-148
curbside antenna cable	4-182
curbside antenna mount assembly	4-190
dc/dc switch	4-156
electronic equipment kit	4-121
electronic equipment table	4-176
electronic line printer rack	4-164
external grounding rod	4-190
faceplate	4-140
ground strap from gusset	4-160
ground strap from powerdistribution box	4-160
guard assembly	4-122
Hubbell connector plug	4-136
key generator rack	4-172
message entry group rack	4-168
pipe nipple	4-154
power cable, 26-foot	4-144
power cable, 26-foot, from circuit breaker box	4-144
power cable from power supply	4-138
power cable, 26-foot, from 4 x 4-inch outlet box.	4-144
power supply, PP-1104.	4-130
power supply, PP-4763.	4-134
power supply cable fromd c/dc switch	4-156
radio mount	4-180
radio mounting bases MT-1029/VRC	4-182
receptacle.	4-140
roadside antenna cable	4-186
roadside antenna mount assembly	4-190
tacfire components	4-158
wall support	4-184
4 x 4-inch outlet box	4-142

INDEX (CONT)

Subject	Page
R (CONT)	
Repair parts and special tools list	C-1
Repair parts, special tools, TMDE and support equipment	C-1
Report of packaging and handling deficiencies	1-1
Reporting equipment improvement recommendations (EIRs)	1-2
Reports of maintenance and unsatisfactory equipment	1-1
Rivnuts, installation	4-50
Roadside antenna cables, installation	4-86
removal	4-186
Roadside antenna mount assembly, installation	4-82
removal	4-190
Routing of cables, curbside antenna	4-74
dc/dc switch	4-64
roadside antenna	4-84
power cable, 26-foot	4-98
S	
Safety care and handling,	1-6
Scope	1-1
Service upon receipt	4-1
Special tools, TMDE and support equipment	4-1
T	
Tacfire Components, installation	4-60
removal	4-158
Tacfire rack, electronic line printer rack	4-12
key generator rack	4-8
message entry group rack	4-10
radio mount	4-
electronics equipment table	4-6
wall support	4-14
Troubleshooting	4-120

INDEX (CONT)

Subject	Page
U	
Unpacking	4-2
W	
Wall support	
installation	4-14
removal	4-184



THEN... JOT DOWN THE DOPE ABOUT IT ON THIS FORM. CAREFULLY TEAR IT OUT, FOLD IT AND DROP IT IN THE MAIL!

SOMETHING WRONG WITH THIS PUBLICATION?

FROM (PRINT YOUR UNIT'S COMPLETE ADDRESS)
 Commander
 Stateside Army Depot
 ATTN: AMSTA-US
 Stateside, N.J. 07703

DATE SENT
 10 July 1975

PUBLICATION NUMBER TM 11-5840-340-12	PUBLICATION DATE 23 Jan 74	PUBLICATION TITLE Radar Set AN/PRC-76
---	-------------------------------	--

BE EXACT PIN-POINT WHERE IT IS				IN THIS SPACE TELL WHAT IS WRONG AND WHAT SHOULD BE DONE ABOUT IT:
PAGE NO	PARA-GRAPH	FIGURE NO	TABLE NO	
2-25	2-28			<p>Recommend that the installation antenna alignment procedure be changed throughout to specify a 2° IFF antenna lag rather than 1°.</p> <p>REASON: Experience has shown that with only a 1° lag, the antenna servo system is too sensitive to wind gusting in excess of 25 knots, and has a tendency to rapidly accelerate and decelerate as it hunts, causing strain to the drive train. Hunting is minimized by adjusting the lag to 2° without degradation of operation.</p>
3-10	3-3		3-1	<p>Item 5, Function column. Change "2 db" to "3db."</p> <p>REASON: The adjustment procedure the the TRANS POWER FAULT indicator calls for a 3 db (500 watts) adjustment to light the TRANS POWER FAULT indicator.</p>
5-6	5-8			<p>Add new step f.1 to read, "Replace cover plate removed in step e.1, above."</p> <p>REASON: To replace the cover plate.</p>
		F03		<p>Zone C 3. On J1-2, change "+24 VDC to "+5 VDC."</p> <p>REASON: This is the output line of the 5 VDC power supply. +24 VDC is the input voltage.</p>

TEAR ALONG PERFORATED LINE

PRINTED NAME, GRADE OR TITLE, AND TELEPHONE NUMBER
 SSG I. M. DeSpiritof 999-1776

SIGN HERE



SOMETHING WRONG WITH THIS PUBLICATION?

THEN...JOT DOWN THE DOPE ABOUT IT ON THIS FORM. CAREFULLY TEAR IT OUT, FOLD IT AND DROP IT IN THE MAIL.

FROM: (PRINT YOUR UNIT'S COMPLETE ADDRESS)

DATE SENT

PUBLICATION NUMBER

TM 11-7440-293-14

PUBLICATION DATE

15 Jun 83

PUBLICATION TITLE

Electronics Equipment Installation Kit MK-1818/GSG-10(V)

BE EXACT PIN-POINT WHERE IT IS

PAGE NO.	PARA-GRAPH	FIGURE NO.	TABLE NO.

IN THIS SPACE TELL WHAT IS WRONG AND WHAT SHOULD BE DONE ABOUT IT:

TEAR ALONG PERFORATED LINE

PRINTED NAME GRADE OR TITLE AND TELEPHONE NUMBER

SIGN HERE

FILL IN YOUR
UNIT'S ADDRESS

FOLD BACK

DEPARTMENT OF THE ARMY

OFFICIAL BUSINESS
PENALTY FOR PRIVATE USE \$300

Commander
US Army Communications-Electronics Command
and Fort Monmouth
ATTN: DRSEL-ME-MP
Fort Monmouth, New Jersey 07703

TEAR ALONG PERFORATED LINE

FILL IN YOUR
UNIT'S ADDRESS

FOLD BACK

DEPARTMENT OF THE ARMY

OFFICIAL BUSINESS
PENALTY FOR PRIVATE USE \$300

Commander
US Army Communications-Electronics Command
and Fort Monmouth
ATTN: DRSEL-ME-MP
Fort Monmouth, New Jersey 07703

TEAR ALONG PERFORATED LINE

RECOMMENDED CHANGES TO EQUIPMENT TECHNICAL PUBLICATIONS



SOMETHING WRONG WITH THIS PUBLICATION?

THEN...JOT DOWN THE DOPE ABOUT IT ON THIS FORM. CAREFULLY TEAR IT OUT, FOLD IT AND DROP IT IN THE MAIL.

FROM: (PRINT YOUR UNIT'S COMPLETE ADDRESS)

DATE SENT

PUBLICATION NUMBER

TM 11-7440-293-14

PUBLICATION DATE

15 Jun 83

PUBLICATION TITLE

Electronics Equipment Installation Kit MK-1818/GSG-10(V)

BE EXACT PIN-POINT WHERE IT IS

PAGE NO.	PARA-GRAPH	FIGURE NO.	TABLE NO.

IN THIS SPACE TELL WHAT IS WRONG AND WHAT SHOULD BE DONE ABOUT IT:

TEAR ALONG PERFORATED LINE

PRINTED NAME GRADE OR TITLE AND TELEPHONE NUMBER

SIGN HERE

DA FORM 2028-2
1 JUL 79

PREVIOUS EDITIONS ARE OBSOLETE

P.S.--IF YOUR OUTFIT WANTS TO KNOW ABOUT YOUR RECOMMENDATION MAKE A CARBON COPY OF THIS AND GIVE IT TO YOUR HEADQUARTERS.

FILL IN YOUR
UNIT'S ADDRESS

FOLD BACK

DEPARTMENT OF THE ARMY

OFFICIAL BUSINESS
PENALTY FOR PRIVATE USE \$300

Commander
US Army Communications-Electronics Command
and Fort Monmouth
ATTN: DRSEL-ME-MP
Fort Monmouth, New Jersey 07703

TEAR ALONG PERFORATED LINE

By Order of the Secretary of the Army:

E. C. MEYER
General, United State Army
Chief of Staff

Official:

ROBERT M. JOYCE
Major General, United States Army
The Adjutant General

DISTRIBUTION:

To be distributed in accordance with Special List.

PIN: 046185-000