

This copy is a reprint which includes current pages from Change 1.

TM 9-2320-209-20-1  
T.O. 36A12-1B-1092-1-1

**TECHNICAL MANUAL**

**VOLUME 1 OF 3**

**SCHEDULED MAINTENANCE**

**ORGANIZATIONAL LEVEL**

**2-1/2-TON, 6X6, M44A1 AND M44A2 SERIES TRUCKS**

**(MULTIFUEL)**

**TRUCK, CARGO: M35A1,  
M35A2, M35A2C, M36A2; TRUCK,  
TANK, FUEL: M49A1C, M49A2C; TRUCK, TANK,  
WATER: M50A1, M50A2, M50A3; TRUCK, VAN,  
SHOP: M109A2, M109A3; TRUCK, REPAIR SHOP:  
M185A2, M185A3; TRUCK, TRACTOR: M275A1,  
M275A2; TRUCK, DUMP: M342A2; TRUCK,  
MAINTENANCE, PIPELINE CONSTRUCTION:  
M756A2; TRUCK, MAINTENANCE,  
EARTH BORING AND POLESETTING: M764**

**Chapter 1  
Preventive  
Maintenance**

**Chapter 2  
Checkout,  
Alinement, and  
Adjustment**

**Chapter 3  
Lubrication**

**Chapter 4  
Scheduled  
Maintenance of  
Material Used  
in Conjunction  
with Major Items**

**Appendix A  
References**

**Appendix B  
Maintenance  
Allocation Chart**

**NOTE:  
THE STYLE OF THIS TM IS  
EXPERIMENTAL. IT IS BEING  
TRIED  
BY THE ARMY ONLY ON  
A LIMITED BASIS**

**DEPARTMENTS OF THE ARMY AND THE AIR FORCE  
MAY 1981**

**WARNING**

**EXHAUST GASES CAN BE DEADLY**

Exposure to exhaust gases produces symptoms of headache, dizziness, loss of muscular control, apparent drowsiness, and coma. Permanent brain damage or death can result from severe exposure.

Carbon monoxide occurs in the exhaust fumes of fuel burning heaters and internal combustion engines, and becomes dangerously concentrated under conditions of inadequate ventilation. The following precautions must be observed to insure the safety of personnel whenever fuel burning heater(s) or engine of any vehicle is operated for maintenance purposes or tactical use.

Do not operate heater or engine of vehicle in an enclosed area unless it is adequately ventilated.

Do not idle engine for long periods without maintaining adequate ventilation in personnel compartments.

Do not drive any vehicle with inspection plates or cover plates removed unless necessary for maintenance purposes.

Be alert at all times during vehicle operation for exhaust odors and exposure symptoms if either are present, immediately ventilate personnel compartments. If symptoms persist, remove affected personnel from vehicle and treat as follows: expose to fresh air; keep warm; do not permit physical exercise; if necessary, administer artificial respiration.

If exposed, seek prompt medical attention for possible delayed onset of acute lung congestion. Administer oxygen if available.

The best defense against exhaust gas poisoning is adequate ventilation.

**WARNING**

**Serious or fatal injury to personnel may result if the following instructions are not complied with.**

Use extreme care when removing radiator cap, especially when temperature gage shows above 180° F.

Always wear leather gloves when handling winch cable. Never allow cable to slip through hands. Do not operate winch with less than four turns of cable on drum.

Do not drive truck until the low air pressure warning buzzer is silent and the air pressure gage shows at least 65 PSI. This is the minimum pressure required for safe braking action.

Do not use hand throttle to drive the vehicle.

Do not park truck with front transmission gearshift lever in gear.

If your vehicle class number is greater than the bridge class number, do not cross.

CHANGE

NO. 1

HEADQUARTERS  
DEPARTMENT OF THE ARMY  
Washington D.C., 4 December 1990

TECHNICAL MANUAL  
VOLUME 1 OF 3  
**SCHEDULED MAINTENANCE**  
ORGANIZATIONAL LEVEL  
**2-1/2 - TON, 6X6, M44A1 AND M44A2 SERIES TRUCKS**  
**(MULTIFUEL)**

**TRUCK, CARGO: M35A1  
M35A2, M35A2C M36A2; TRUCK,  
TANK, FUEL: M49A1C, M49A2C, TRUCK,  
WATER: M50A1, M50A2, M50A3, TRUCK VAN,  
SHOP: M109A2, M109A3.; TRUCK, REPAIR SHOP:  
M185A2, M185A3; TRUCK, TRACTOR: M275A1,  
M275A2; TRUCK, DUMP: M342A2; TRUCK,  
MAINTENANCE, PIPELINE CONSTRUCTION:  
M756A2; TRUCK, MAINTENANCE,  
EARTH BORING AND POLE SETTING: M764**

TM 9-2320-209-20-1, dated 27 May 1981 is changed as follows:

1. Remove old pages and insert new pages as indicated below.
2. New or changed material is indicated by a vertical bar in the margin of the page.

Remove Pages  
1-9 and 1-10

Insert Pages  
1-8.1 thru 1-10

File this change sheet in front of the publication for reference purposes.

By Order of the Secretary of the Army

CARL E. VUONO  
*General, United States Army*  
*Chief of Staff*

THOMAS F. SIKORA  
*Brigadier General, United States Army*  
*The Adjutant General*

Distribution:

To be distributed in accordance with DA Form 12-38-E (Block 0186) Unit maintenance requirements for TM 9-2320-209-20-1

TECHNICAL MANUAL  
No. 9-2320-209-20-1  
TECHNICAL ORDER  
No. 36A12-1B-1092-1-1

DEPARTMENTS OF THE ARMY  
AND  
THE AIR FORCE  
Washington, DC, 27 May 1981

TECHNICAL MANUAL  
VOLUME 1 OF 3  
**SCHEDULED MAINTENANCE**  
ORGANIZATIONAL LEVEL  
**2-1/2-TON, 6X6, M44A1 AND M44A2 SERIES TRUCKS**  
**(MULTIFUEL)**

Model		NSN without Winch	NSN with Winch
Truck, Cargo	M35A1	2320-00-542-5633	2320-00-542-5634
	M35A2	2320-00-077-1616	2320-00-077-1617
	M35A2C	2320-00-926-0873	2320-00-926-0875
	M36A2	2320-00-077-1618	2320-00-077-1619
Truck, Tank, Fuel	M49A1C	2320-00-440-3349	2320-00-440-3346
	M49A2C	2320-00-077-1631	2320-00-077-1632
Truck, Tank, Water	M50A1	2320-00-440-8307	2320-00-440-8305
	M50A2	2320-00-077-1633	2320-00-077-1634
	M50A3	2320-00-937-4036	2320-00-937-5264
Truck, Van, Shop	M109A2	2320-00-440-8313	2320-00-440-8308
	M109A3	2320-00-077-1636	2320-00-077-1637
Truck, Repair Shop	M185A2	4940-00-987-8799	4940-00-987-8800
	M185A3	4940-00-077-1638	4940-00-077-1639
Truck, Tractor	M275A1	2320-00-446-2479	
	M275A2	2320-00-077-1640	2320-00-077-1641
Truck, Dump	M342A2	2320-00-077-1643	2320-00-077-1644
Truck, Maintenance, Pipeline Construction	M756A2		2320-00-904-3277
Truck, Maintenance, Earth Boring and Polesetting	M764		2320-00-937-5980

\*This manual, together with TM 9-2320-209-20-2-1, 27 May 1981; TM 9-2320-209-20-2-2, 27 May 1981; TM 9-2320-209-20-3-1, 27 May 1981; TM 9-2320-209-20-3-2, 27 May 1981; TM 9-2320-209-20-3-3, 27 May 1981; and TM 9-2320-209-20-3-4, 27 May 1981, supersedes TM 9-2320-209-20-1, 31 August 1978.

**REPORTING OF ERRORS AND RECOMMENDING IMPROVEMENTS**

You can help improve this manual. If you find any mistake or if you know of a way to improve the procedure, please let us know. Mail your letter, DA Form 2028 (Recommended Changes to Publication and Blank Forms), or DA Form 2028-2 located in the back of this manual direct to: Commander, U.S. Army Tank Automotive Materiel Readiness Command, ATTN: DRSTA-MB, Warren, Michigan 48090. A reply will be furnished to you.

**TABLE OF CONTENTS**

	Paragraph	Page
CHAPTER 1. PREVENTIVE MAINTENANCE		
General .....	1-1	1-1
Procedures for Services and Inspection.....	1-2	1-1
PMCS Procedures .....	1-3	1-2
CHAPTER 2. CHECKOUT, ALINEMENT, AND ADJUSTMENT		
General .....	2-1	2-1
CHAPTER 3. LUBRICATION		
General .....	3-1	3-1
Special Instructions .....	3-2	3-1
CHAPTER 4. SCHEDULED MAINTENANCE OF MATERIAL USED IN CONJUNCTION WITH MAJOR ITEMS		
General .....	4-1	4-1
PMCS Procedures .....	4-2	4-1
APPENDIX A. REFERENCES .....		A-1
APPENDIX B. MAINTENANCE ALLOCATION CHART.....		B-1

VOLUME 2 OF 3

Part 1 of 2  
( TM 9-2320-209-20-2-1 )

CHAPTER 1. GENERAL INFORMATION.....	1-1
CHAPTER 2. TROUBLESHOOTING APPROACH.....	2-1
CHAPTER 3. TROUBLESHOOTING INDEX.....	3-1
CHAPTER 4. TEST EQUIPMENT PROCEDURES INDEX.....	4-1
CHAPTER 5. TROUBLESHOOTING ROADMAPS .....	5-1
CHAPTER 6. FAULT SYMPTOM INDEXES.....	6-1
CHAPTER 7. SAMPLE TROUBLESHOOTING PROCEDURE.....	7-1
CHAPTER 8. ENGINE SYSTEM TROUBLESHOOTING.....	8-1
CHAPTER 9. ENGINE SYSTEM TROUBLESHOOTING SUMMARY .....	9-1
CHAPTER 10. ENGINE DRIVELINE SUBSYSTEM TROUBLESHOOTING.....	10-1
CHAPTER 11. CLUTCH SYSTEM TROUBLESHOOTING.....	11-1
CHAPTER 12. CLUTCH SYSTEM TROUBLESHOOTING SUMMARY .....	12-1
CHAPTER 13. FUEL SYSTEM TROUBLESHOOTING.....	13-1
CHAPTER 14. FUEL SYSTEM TROUBLESHOOTING SUMMARY .....	14-1
CHAPTER 15. FUEL SYSTEM SUPPORT DIAGRAMS.....	15-1
CHAPTER 16. FUEL SYSTEM TEST PROCEDURES.....	16-1
CHAPTER 17. EXHAUST SYSTEM TROUBLESHOOTING .....	17-1
CHAPTER 18. EXHAUST SYSTEM TROUBLESHOOTING SUMMARY .....	18-1

TABLE OF CONTENTS-CONT

	Paragraph	Page
CHAPTER 19. EXHAUST SYSTEM SUPPORT DIAGRAMS.....		19-1
CHAPTER 20. COOLING SYSTEM TROUBLESHOOTING .....		20-1
CHAPTER 21. COOLING SYSTEM TROUBLESHOOTING SUMMARY .....		21-1
CHAPTER 22. COOLING SYSTEM SUPPORT DIAGRAMS .....		22-1
CHAPTER 23. COOLING SYSTEM TEST PROCEDURES.....		23-1
CHAPTER 24. COOLING SYSTEM CHECKOUT PROCEDURES.....		24-1
CHAPTER 25. ELECTRICAL SYSTEM TROUBLESHOOTING.....		25-1

Part 2 of 2  
( TM 9-2320-209-20-2-2 )

CHAPTER 26. ELECTRICAL SYSTEM TROUBLESHOOTING SUMMARY .....		26-1
CHAPTER 27. ELECTRICAL SYSTEM SUPPORT DIAGRAMS.....		27-1
CHAPTER 28. MULTIMETER TEST PROCEDURES .....		28-1
CHAPTER 29. OPERATING AND PRELIMINARY PROCEDURES .....		29-1
CHAPTER 30. ELECTRICAL SYSTEM CHECKOUT PROCEDURES.....		30-1
CHAPTER 31. TRANSMISSION SYSTEM TROUBLESHOOTING .....		31-1
CHAPTER 32. TRANSMISSION SYSTEM TROUBLESHOOTING SUMMARY .....		32-1
CHAPTER 33. TRANSFER SYSTEM TROUBLESHOOTING.....		33-1
CHAPTER 34. TRANSFER SYSTEM TROUBLESHOOTING SUMMARY .....		34-1
CHAPTER 35. TRANSFER SYSTEM CHECKOUT PROCEDURES .....		35-1
CHAPTER 36. PROPELLER SHAFT SYSTEM TROUBLESHOOTING.....		36-1
CHAPTER 37. PROPELLER SHAFT SYSTEM TROUBLESHOOTING SUMMARY .....		37-1
CHAPTER 38. PROPELLER SHAFT SYSTEM SUPPORT DIAGRAMS.....		38-1
CHAPTER 39. FRONT AXLE SYSTEM TROUBLESHOOTING.....		39-1
CHAPTER 40. FRONT AXLE SYSTEM TROUBLESHOOTING SUMMARY .....		40-1
CHAPTER 41. FRONT AXLE SYSTEM CHECKOUT PROCEDURES .....		41-1
CHAPTER 42. REAR AXLE SYSTEM TROUBLESHOOTING .....		42-1
CHAPTER 43. REAR AXLE SYSTEM SUPPORT DIAGRAMS.....		43-1
CHAPTER 44. BRAKE SYSTEM TROUBLESHOOTING .....		44-1
CHAPTER 45. BRAKE SYSTEM TROUBLESHOOTING SUMMARY .....		45-1
CHAPTER 46. BRAKE SYSTEM SUPPORT DIAGRAMS .....		46-1
CHAPTER 47. HANDBRAKE SUBSYSTEM TROUBLESHOOTING.....		47-1
CHAPTER 48. COMPRESSED AIR SUBSYSTEM TROUBLESHOOTING.....		48-1
CHAPTER 49. BRAKE SYSTEM TEST PROCEDURES.....		49-1
CHAPTER 50. BRAKE SYSTEM CHECKOUT PROCEDURES.....		50-1
CHAPTER 51. WHEEL SYSTEM TROUBLESHOOTING.....		51-1

## TABLE OF CONTENTS-CONT

	Paragraph	Page
CHAPTER 52. STEERING SYSTEM TROUBLESHOOTING.....		52-1
CHAPTER 53. STEERING SYSTEM TROUBLESHOOTING SUMMARY.....		53-1
CHAPTER 54. STEERING SYSTEM SUPPORT DIAGRAMS .....		54-1
CHAPTER 55. SPRING AND SHOCK ABSORBERS SYSTEM TROUBLESHOOTING.....		55-1
CHAPTER 56. SPRING AND SHOCK ABSORBERS SYSTEM TROUBLE- SHOOTING SUMMARY .....		56-1
CHAPTER 57. DUMP BODY TROUBLESHOOTING.....		57-1
CHAPTER 58. DUMP BODY TROUBLESHOOTING SUMMARY .....		58-1
CHAPTER 59. DUMP BODY SUPPORT DIAGRAMS.....		59-1
CHAPTER 60. DUMP BODY CHECKOUT PROCEDURES.....		60-1
CHAPTER 61. WATER TANK BODY TROUBLESHOOTING.....		61-1
CHAPTER 62. WATER TANK BODY TROUBLESHOOTING SUMMARY .....		62-1
CHAPTER 63. WATER TANK BODY SUPPORT DIAGRAMS.....		63-1
CHAPTER 64. WATER TANK BODY CHECKOUT PROCEDURES .....		64-1
CHAPTER 65. FUEL TANK BODY (TRUCK M49A1C) TROUBLESHOOTING .....		65-1
CHAPTER 66. FUEL TANK BODY (TRUCK M49A1C) TROUBLESHOOTING SUMMARY .....		66-1
CHAPTER 67. FUEL TANK BODY (TRUCK M49A1C) SUPPORT DIAGRAMS.....		67-1
CHAPTER 68. FUEL TANK BODY (TRUCK M49A1C) CHECKOUT PROCEDURES .....		68-1
CHAPTER 69. FUEL TANK BODY (TRUCK M49A2C) TROUBLESHOOTING .....		69-1
CHAPTER 70. FUEL TANK BODY (TRUCK M49A2C) TROUBLESHOOTING SUMMARY .....		70-1
CHAPTER 71. FUEL TANK BODY (TRUCK M49A2C) SUPPORT DIAGRAMS.....		71-1
CHAPTER 72. FUEL TANK BODY (TRUCK M49A2C) CHECKOUT PROCEDURES .....		72-1
CHAPTER 73. EARTH BORING MACHINE TROUBLESHOOTING.....		73-1
CHAPTER 74. EARTH BORING MACHINE TROUBLESHOOTING SUMMARY .....		74-1
CHAPTER 75. EARTH BORING MACHINE SUPPORT DIAGRAMS .....		75-1
CHAPTER 76. EARTH BORING MACHINE SUPPORT PROCEDURES.....		76-1
CHAPTER 77. FRONT WINCH TROUBLESHOOTING.....		77-1
CHAPTER 78. FRONT WINCH TROUBLESHOOTING SUMMARY.....		78-1
CHAPTER 79. FRONT WINCH CHECKOUT PROCEDURES .....		79-1
CHAPTER 80. EARTH BORING MACHINE REAR WINCH TROUBLE- SHOOTING .....		80-1

TABLE OF CONTENTS-CONT

	Paragraph	Page
CHAPTER 81. PIPELINE CONSTRUCTION TRUCK REAR WINCH TROUBLESHOOTING .....		81-1
CHAPTER 82. ENGINE COOLANT HEATER TROUBLESHOOTING .....		82-1
CHAPTER 83. ENGINE COOLANT HEATER TROUBLESHOOTING SUMMARY .....		83-1
CHAPTER 84. ENGINE COOLANT HEATER SUPPORT DIAGRAMS.....		84-1
CHAPTER 85. ENGINE COOLANT HEATER TEST PROCEDURES.....		85-1
CHAPTER 86. ENGINE COOLANT HEATER CHECKOUT PROCEDURES .....		86-1
CHAPTER 87. FUEL BURNING PERSONNEL HEATER TROUBLESHOOTING.....		87-1
CHAPTER 88. FUEL BURNING PERSONNEL HEATER TROUBLESHOOTING SUMMARY .....		88-1
CHAPTER 89. FUEL BURNING PERSONNEL HEATER SUPPORT DIAGRAMS .....		89-1
CHAPTER 90. FUEL BURNING PERSONNEL HEATER CHECKOUT PROCEDURES .....		90-1
CHAPTER 91. HOT WATER HEATER TROUBLESHOOTING.....		91-1
CHAPTER 92. HOT WATER HEATER TROUBLESHOOTING SUMMARY .....		92-1
CHAPTER 93. HOT WATER HEATER CHECKOUT PROCEDURES .....		93-1
CHAPTER 94. DEEP WATER FORDING KIT TROUBLESHOOTING.....		94-1
CHAPTER 95. DEEP WATER FORDING KIT TROUBLESHOOTING SUMMARY .....		95-1
CHAPTER 96. DEEP WATER FORDING KIT SUPPORT DIAGRAMS.....		96-1
CHAPTER 97. DEEP WATER FORDING KIT CHECKOUT PROCEDURES .....		97-1
CHAPTER 98. NON-ELECTRICAL GAGES TROUBLESHOOTING.....		98-1
CHAPTER 99. NON-ELECTRICAL GAGES TROUBLESHOOTING SUMMARY .....		99-1
CHAPTER 100. NON-ELECTRICAL GAGES SUPPORT DIAGRAMS .....		100-1

VOLUME 3 OF 3

Part 1 of 4  
( TM 9-2320-209-20-3-1 )

CHAPTER 1. GENERAL MAINTENANCE INFORMATION .....	1-1
CHAPTER 2. ENGINE SYSTEM GROUP MAINTENANCE	
Section I. Scope .....	2-1
Section II. Engine Assembly.....	2-1



TABLE OF CONTENTS-CONT

	Paragraph	Page
Section III. Engine Lubrication System.....		2-13
CHAPTER 3. CLUTCH SYSTEM GROUP MAINTENANCE		
Section I. Scope .....		3-1
Section II. Clutch Linkage Assembly .....		3-1
CHAPTER 4. FUEL SYSTEM GROUP MAINTENANCE		
Section I. Scope .....		4-1
Section II. Air Cleaner.....		4-1
Section III. Fuel Tanks and Fuel Lines .....		4-8
Section IV. Fuel Filter.....		4-55
Section V. Engine Starting Aids.....		4-71
Section VI. Accelerator, Throttle, and Engine Stop Controls.....		4-157
CHAPTER 5. EXHAUST SYSTEM GROUP MAINTENANCE		
Section I. Scope .....		5-1
Section II. Exhaust Pipes and Mufflers .....		5-1
CHAPTER 6. COOLING SYSTEM GROUP MAINTENANCE		
Section I. Scope .....		6-1
Section II. Radiator Assembly.....		6-1
Section III. Thermostat.....		6-31
Section IV. Water Pump .....		6-39
Section V. Fan Assembly and Related Parts.....		6-42
Section VI. Cooling System Service .....		6-49
CHAPTER 7. ELECTRICAL GROUP MAINTENANCE		
Section I. Scope .....		7-1
Section II. Charging System.....		7-1
Section III. Starting System.....		7-29
Section IV. Instrument Panel Components.....		7-64
Section V. Lighting System.....		7-88
Section VI. Sending Unit Gages and Warning Buzzers .....		7-181
Section VII. Horn Assembly .....		7-190
Section VIII. Battery System.....		7-204
Section IX. Chassis Harness.....		7-227
Section X. Miscellaneous Items.....		7-242
CHAPTER 8. TRANSMISSION GROUP MAINTENANCE		
Section I. Scope .....		8-1
Section II. Transmission Breather .....		8-1
CHAPTER 9. TRANSMISSION TRANSFER GROUP MAINTENANCE		
Section I. Scope .....		9-1
Section II. Transmission Transfer Control and Linkage Assembly .....		9-1
CHAPTER 10. PROPELLER SHAFTS GROUP MAINTENANCE		
Section I. Scope .....		10-1
Section II. Propeller Shafts Assemblies.....		10-1
CHAPTER 11. FRONT AXLE GROUP MAINTENANCE		
Section I. Scope .....		11-1
Section II. Front Axle Assembly .....		11-1
Section III. Steering Mechanism .....		11-18

TABLE OF CONTENTS-CONT

	Paragraph	Page
CHAPTER 12. REAR AXLE GROUP MAINTENANCE		
Section I. Scope .....		12-1
Section II. Rear Axle Assembly.....		12-1
Part 2 of 4 ( TM 9-2320-209-20-3-2 )		
CHAPTER 13. BRAKE SYSTEM GROUP MAINTENANCE		
Section I. Scope .....		13-1
Section II. Handbrake Assembly and Related Parts .....		13-1
Section III. Service Brake.....		13-49
Section IV. Hydraulic Brake System.....		13-73
Section V. Mechanical Brake System.....		13-134
Section VI. Air Brake System.....		13-148
Section VII. Compressed Air System.....		13-237
Section VIII. Trailer Brake Connections .....		13-267
CHAPTER 14. WHEEL GROUP MAINTENANCE		
Section I. Scope .....		14-1
Section II. Front Wheel Assembly .....		14-1
Section III. Rear Wheel Assembly.....		14-46
Section IV. Tires .....		14-73
CHAPTER 15. STEERING SYSTEM GROUP MAINTENANCE		
Section I. Scope .....		15-1
Section II. Mechanical Steering Gear Assembly.....		15-1
CHAPTER 16. FRAME AND TOWING ATTACHMENTS GROUP MAINTENANCE		
Section I. Scope .....		16-1
Section II. Pintle and Towing Attachments.....		16-1
Section III. Spare Wheel Carrier .....		16-17
Section IV. Fifth Wheel Assembly.....		16-48
CHAPTER 17. SPRINGS AND SHOCK ABSORBERS GROUP MAINTENANCE		
Section I. Scope .....		17-1
Section II. Springs .....		17-1
Section III. Shock Absorbers .....		17-57
Section IV. Torque Rods.....		17-61
Part 3 of 4 (TM 9-2320-209-20-3-3 )		
CHAPTER 18. BODY, CAB, HOOD, AND HULL GROUP MAINTENANCE		
Section I. Scope .....		18-1
Section II. Cab Components.....		18-1
Section III. Windshield Assembly .....		18-14
Section IV. Seats .....		18-18
Section V. Brackets and Straps.....		18-46
Section VI. Cargo Body Components .....		18-48
Section VII. Tank Body Components.....		18-67
Section VIII. Special Purpose Bodies .....		18-359

TABLE OF CONTENTS-CONT

Part 4 of 4  
( TM 9-2320-209-20-3-4 )

	Paragraph	Page
CHAPTER 19. WINCH AND HOIST ASSEMBLIES AND POWER TAKEOFF CONTROLS AND LINKAGE GROUP MAINTENANCE		
Section I. Scope .....		19-1
Section II. Winch and Hoist Assemblies .....		19-1
Section III. Power Takeoff Controls and Linkage.....		19-129
CHAPTER 20. BUMPER GUARDS GROUP MAINTENANCE		
Section I. Scope .....		20-1
Section II. Bumper Brackets, Guards, and Protective Devices .....		20-1
CHAPTER 21. BODY ACCESSORY ITEMS GROUP MAINTENANCE		
Section I. Scope .....		21-1
Section II. Canvas Accessory Items .....		21-1
Section III. Cab Accessory Items .....		21-4
Section IV. Data Plates .....		21-24
CHAPTER 22. NONELECTRICAL GAGES GROUP MAINTENANCE		
Section I. Scope .....		22-1
Section II. Nonelectrical gages.....		22-1
CHAPTER 23. MAINTENANCE OF MATERIAL USED IN CONJUNCTION WITH MAJOR ITEMS		
Section I. Scope .....		23-1
Section II. Winterization Kits.....		23-1
Section III. Deep Water Fording Kit.....		23-103
Section IV. Special Purpose Kits.....		23-120
APPENDIX A. REFERENCES .....		A-1
INDEX.....		Index 1

## CHAPTER 1 PREVENTIVE MAINTENANCE

---

1-1. GENERAL. Preventive maintenance checks and services (PMCS) are done to find and to fix problems before they can cause major damage to the vehicle. These checks and services are done by organizational maintenance personnel every six months or 6,000 miles, whichever comes first. To save time and make sure that all items are checked, do the PMCS in the order given in the tables. Write down any problems on the proper forms. Refer to TM 38-750.

1-2. PROCEDURES FOR SERVICES AND INSPECTIONS. The following general procedures are for organizational maintenance PMCS and for all inspections. They are just as important as the specific procedures. In addition to the specific procedures, any of these general procedures that apply to PMCS items will be done automatically.

a. Check to see if items are in good condition, properly assembled or stowed, not leaking, loose, or excessively worn, and properly lubricated.

(1) Check that items are in good condition is usually a visual check to see if the items are safe and usable. Good condition means not bent or twisted, not chafed or burred, not broken or cracked, not bare or frayed, not dented or collapsed, not torn or cut, not rusted or rotted, and not leaking.

(2) Check that items are properly assembled or stowed usually is a visual inspection also. See if the items are in normal positions on the vehicle, and if all parts are present.

(3) Excessively worn means worn beyond usable limits and likely to fail before the next scheduled inspection. This includes too much play (lash or lost motion) in linkages and mating parts. This also includes unreadable markings, data and caution plates, and other printed matter.

b. The specific PMCS procedures do not say "adjust if necessary" or "replace if necessary." It is understood that whenever inspection shows the need for adjustments, repairs, or replacements that work will be done.

c. Any special cleaning instructions for certain items are in the maintenance sections for those items. General cleaning instructions are as follows:

### **WARNING**

**Dry cleaning solvent is flammable. Do not use near an open flame. Keep a fire extinguisher nearby when solvent is used. Use only in well-ventilated places. Failure to do this may result in injury to personnel and damage to equipment.**

(1) Use dry cleaning solvent, Type II (SD-2), Fed. Spec P-D-680 to clean or wash grease or oil from all metal parts.

(2) A solution of one part grease cleaning compound to four parts of dry cleaning solvent may be used for cleaning grease and oil from engine blocks, engine compartments, and other parts.

(3) After cleaning, rinse and dry parts well. Coat all polished metal surfaces with a light grade of oil to stop rust.

(4) When putting in new parts, take off any rust-preventive compound or protective grease. For those parts needing lubrication, refer to LO 9-2320-209-12/1.

d. To stop mildew from forming, shake out and air canvas covers often for several hours at a time. Have any loose grommets or rips in the fabric fixed right away. Failure to do so may cause minor damage to become major damage. Clean mildew from canvas with a dry brush. If water is needed to wash off dirt, it must not be used until all mildew has been brushed off. If mildew is present, carefully check the canvas for weak spots. If weak spots are found, the canvas is probably not worth retreatment. Otherwise, have the canvas retreated. Clean off oil and grease with issue soap and warm water. Rinse well with clean water and dry.

e. Steel nameplates, caution plates, and instruction plates may rust rapidly. If rusty, clean plates well and coat heavily with clear lacquer. Refer to TM 43-0139.

f. General precautions for cleaning are in the maintenance sections.

g. The vehicle operator usually helps organizational maintenance personnel in doing the PMCS. The operator should make sure the vehicle is fairly clean. However, the vehicle should not be washed right before inspection. Certain problems, such as loose parts or oil leaks may not show up after a wash.

h. The only organizational maintenance services are those general procedures listed below, unless approval is given for other service.

(1) Adjust. Make all adjustments by following the procedures given in this manual or in bulletins.

(2) Clean. Clean items by following the general cleaning procedures given in paragraph c., above.

(3) Service. Normally, service includes filling the battery with water, draining and refilling items with oil, and changing or cleaning the oil filter, air cleaner or cartridges.

(4) Tighten. Tighten items with enough force on the wrench handle to tighten according to good mechanical practice. Do not overtighten; this may strip threads or cause distortion. Tightening includes using lockwashers, locknuts, lock wire, or cotter pins when needed. Use a torque wrench when the procedure calls for one.

(5) Modification work order application. Write all needed modification work orders (MWO) for the vehicle on DA Form 2408-5.

i. When it is hard to do all of the PMCS procedures at one time, they can sometimes be done in parts. If possible, plan to do all the procedures within one week. All available time at halts and in bivouac areas must be used, if needed, to make sure that the PMCS is done.

1-3. PMCS PROCEDURES. Figure 1-1 gives location of components and table 1-1 gives the PMCS procedures for the basic vehicle. Figures and tables which follow cover PMCS special to the various vehicle models, and not listed in Table 1-1. The PMCS tables are made up of the following columns:

a. Item No. Column. This column gives the order in which the checks and services are to be done. Use these item numbers when filling out equipment inspection and maintenance forms.

b. Item to be Inspected Column. This column names the item or system to be checked or serviced.

c. Blank Column. You should ignore this column because it is not required for organizational maintenance PMCS. Contents were deleted, at the time of printing, due to policy changes.

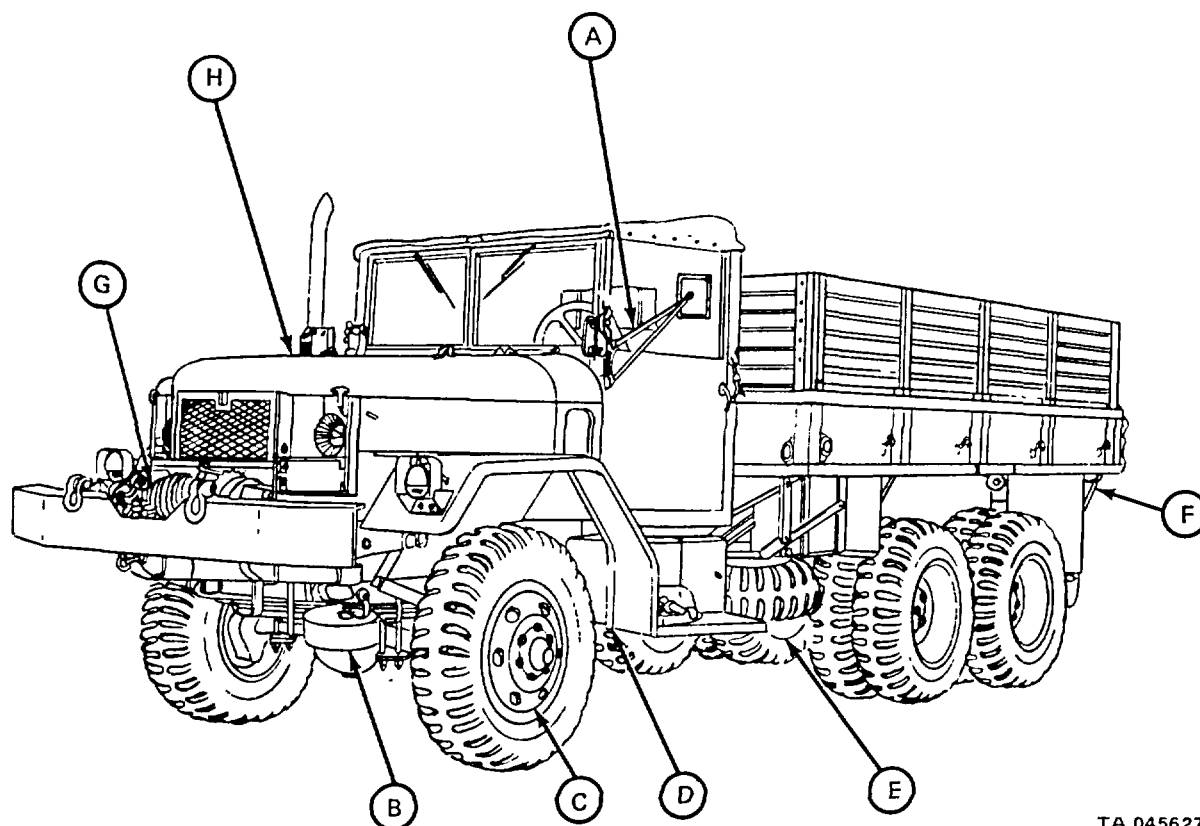

TA 045627

- |   |   |
|---|---|
| <p>A. Controls</p>  | <p>E. Rear axles<br/>Rear differentials<br/>Rear springs</p>  |
| <p>B. Front axle<br/>Front differential<br/>Front springs and shock absorbers</p>                           | <p>F. Body and frame</p>  |
| <p>C. Wheel hubs<br/>Brake drums<br/>Wheels and tires</p>   | <p>G. Front winch</p>   |
| <p>D. Transmission<br/>Transfer case<br/>Propeller shafts<br/>Air reservoirs<br/>Air-hydraulic cylinder</p> | <p>H. Air cleaner system<br/>Engine crankcase breather<br/>Manifold preheater<br/>Fuel filters and fuel lines<br/>Oil filters</p> |

Figure 1-1. Preventive Maintenance Locators.

Table 1-1. Organizational Preventive Maintenance Checks and Services Semiannual Schedule

Item No.	Item To Be Inspected	Procedures Check for and Have Repaired, Replaced, Adjusted as Necessary	
1		<p style="text-align: center;">BEFORE ROAD TEST</p> <p>Check that all before operation checks listed in TM 9-2320-209-10 have been done.</p>	
2	Lubrication	<p>Refer to Lubrication Order LO 9-2320-209-12/1 for lubrication of truck.</p>	
3	THROTTLE control	<p style="text-align: center;">DURING ROAD TEST</p> <p>1. Check travel and free movement of THROTTLE control (1) by watching accelerator pedal (2). When THROTTLE control is pulled out all the way, accelerator pedal will be down against stop screw. Check that THROTTLE control does not bind or stick in any position.</p> <div style="text-align: center;">  <p style="text-align: right;">TA 080484</p> </div>	

Table 1-1. Organizational Preventive Maintenance Checks and Services Semiannual Schedule - Cont

Item No.	Item To Be Inspected	Procedures Check for and Have Repaired, Replaced, Adjusted as Necessary	
3 (cont)		<ol style="list-style-type: none"> <li>2. Start engine. Refer to TM 9-2320-209-10.</li> <li>3. Look at tachometer (3) and check that engine does not go faster than governed speed (2850 rpm).</li> </ol>	
4	Clutch	<ol style="list-style-type: none"> <li>1. Push down on clutch pedal (1), and listen for bad clutch release bearing or other noises.</li> </ol> <div style="text-align: center;"> <p>TA 080485</p> </div> <ol style="list-style-type: none"> <li>2. Check that free travel of clutch pedal (1) is about 1-1/2 to 2 inches.</li> <li>3. Put truck in motion and check that clutch does not slip, grab, or chatter.</li> </ol>	

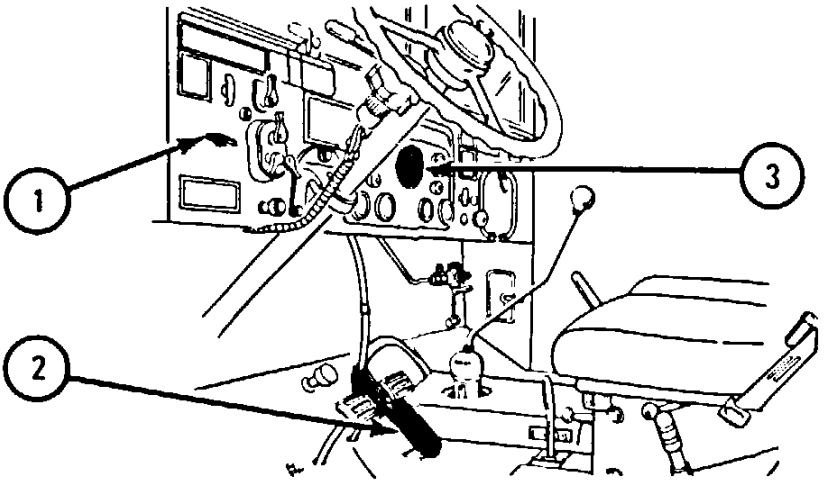

Table 1-1. Organizational Preventive Maintenance Checks and Services Semiannual Schedule - Cont

Item No.	Item To Be Inspected	Procedures Check for and Have Repaired, Replaced, Adjusted as Necessary	
5	Brake system	<ol style="list-style-type: none"> <li>1. Raise truck speed until speedometer (2) reads about 40 mph and brake to a stop. Check that truck stops smoothly without sidepull, chatter, or unusual noise.</li> <li>2. Check that brake pedal (3) does not bind.</li> <li>3. Check that brake pedal (3) stops about two inches above floor.</li> </ol>	
6	Steering system	<ol style="list-style-type: none"> <li>1. Check that free play at steering wheel (4) is not more than one inch.</li> <li>2. Check that there is no shimmy, wander or pull to one side.</li> <li>3. Turn steering wheel (4) through full range and check that there is no binding in steering system.</li> </ol>	
7	Transmission and transfer case	<ol style="list-style-type: none"> <li>1. Shift FRONT TRANSMISSION gear shift lever (1) and TRANSFER CASE shift lever (2) into all gears. Check that there is no unusual stiffness when shifting and no slipping out of gear.</li> </ol>	

Table 1-1. Organizational Preventive Maintenance Checks and Services Semiannual Schedule - Cont

Item No.	Item To Be Inspected	Procedures Check for and Have Repaired, Replaced, Adjusted as Necessary	
7 (cont)		 <p style="text-align: right;">TA 080486</p>	
8	Engine power	<p>2. Be alert for unusual noises or vibrations in power train.</p> <p>1. Check that engine has normal power and acceleration in all speeds.</p> <p>2. Be alert for unusual engine noises.</p> <p style="text-align: center;">AFTER ROAD TEST</p>	
9	Wheel hubs, brake drums, and power train	<p>1. Stop engine. Refer to TM 9-2320-209-10.</p> <p style="text-align: center;"><b><u>WARNING</u></b></p> <p style="text-align: center;"><b>Use care when touching these units with your hands right after road test. These units may be very hot.</b></p>	

Table 1-1. Organizational Preventive Maintenance Checks and Services Semiannual Schedule - Cont

Item No.	Item To Be Inspected	Procedures Check for and Have Repaired, Replaced, Adjusted as Necessary	
9 (cont)		<p>2. Right after road test, carefully feel wheel hubs (1), brake drums (2), transmission (3), transfer case (4), and differentials (5).</p>  <p style="text-align: center;">TA 080579</p> <p>(a) If wheel hubs (1) are very hot, wheel bearings may be bad, not properly adjusted, or not properly greased.</p> <p>(b) If brake drums (2) are cool or very hot, brakes are not properly adjusted.</p>	

Table 1-1. Organizational Preventive Maintenance Checks and Services Semiannual Schedule - Cont

Item No.	Item To Be Inspected	Procedures Check for and Have Repaired, Replaced, Adjusted as Necessary	
9 (cont)		<p>(a) If Transmission (3) or differential (5) are very hot, they may be bad or not properly lubricated.</p> <p>(b) It is normal for the transfer case (4) to be hot after truck has been run for a while. If it is properly lubricated and did not make noise, it is good.</p>	
9.1	Brake system	<p>(a) Check brakeshoe (5) condition. If brakeshoes (5) are worn beyond .331 in. (8.4 mm), replace. Refer to Vol 3, para 13-8, 13-9, and 13-10.</p> <p>(b) Inspect master cylinder (6) and wheel cylinders (10) to make sure they are not loose, leaking or damaged. If loosen tighten. If damaged, replace. Refer to Vol 3, para 13-11 and 13-12.</p> <div data-bbox="625 776 1348 1110" style="text-align: center;"> </div>	

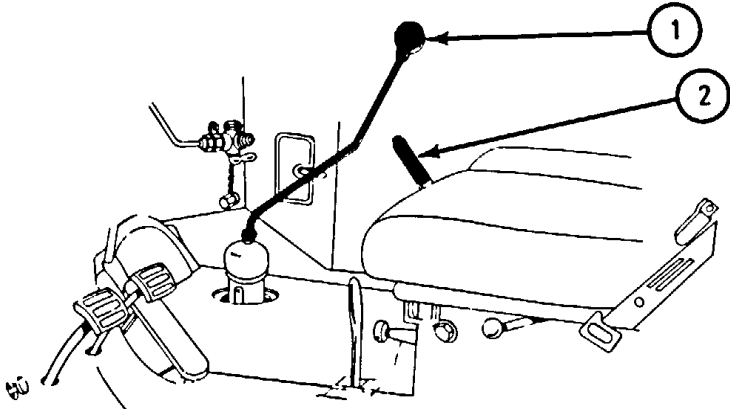
Table 1-1. Organizational Preventive Maintenance Checks and Services Semiannual Schedule - Cont

Item No.	Item To Be Inspected	Procedures Check for and Have Repaired, Replaced, Adjusted as Necessary	
9.1 (cont)	Brake system	<p>(c) Inspect air-hydraulic cylinder (7) to make sure it is not loose, leaking, or damaged. If loose, tighten. If damaged, replace. Refer to Vol 3, para 13-14.</p> <p style="text-align: center;"><b><u>WARNING</u></b></p> <p style="text-align: center;"><b>Make sure new longer front brake shoe hoses, currently used on 5 ton trucks are installed on all 2 1/2 ton trucks. Old, shorter front brake hoses are subject to failure during full steering travel and must be replaced with new, longer front brake hoses. Failure to do this could result in injury or death to personnel.</b></p> <p>(d) Inspect all flexible hydraulic brake hoses for bulges, pinches, cracks, crimping chafing, abrasions, or leaks. If any of these conditions exist, replace or reposition hoses to prevent failure. Check front brake hoses (11) for loose or missing fittings, and make sure they are long enough to allow full steering travel. If brake hose (11) is too short, it must be replaced with new, longer hose. Refer to Vol 3, para 13-13.</p> 	

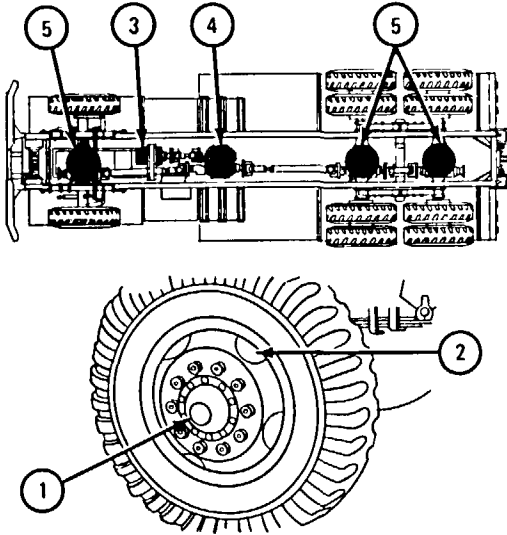
Table 1-1. Organizational Preventive Maintenance Checks and Services Semiannual Schedule - Cont

Item No.	Item To Be Inspected	Procedures Check for and Have Repaired, Replaced, Adjusted as Necessary	
9.1 (cont)		<p>(e) Inspect parking brakeshoes for wear. Replace both if lining thickness is 3/16 in. (4.76 mm) or less. Refer to Vol 3, para 13-4.</p> <p>(f) Inspect parking brake cable, lever, and brakeshoe assembly for binding and loose or missing components. Tighten components if loose or replace if missing or damaged. Refer to Vol 3, para 13-5 and 13-6.</p>  <p style="text-align: center;">Parking Brake Drum</p> <p>(g) Check parking brakeshoe clearance between inner and outer parking brake linings and parking brake drum at both ends (A and B), at the same time. If parking brakeshoe clearance is not 0.015 in. (0.397 mm), adjust parking brake as necessary. Refer to Vol 3, para 13-7.</p>	
10	Front Axle	<p>1. Using torque wrench with 3/4-inch socket, tighten front axle drive flange bolts (1) to 60 to 80 lb-ft (81-108 Nm).</p> 	

Table 1-1. Organizational Preventive Maintenance Checks and Services Semiannual Schedule - Cont

Item No.	Item To Be Inspected	Procedures Check for and Have Repaired, Replaced, Adjusted as Necessary	
10 (cont)	Front axle	 <ol style="list-style-type: none"> <li>2. Check that springs (1) and shock absorbers (2) are not loose or damaged.</li> <li>3. Check that steering knuckle boots (3) are not torn.</li> </ol>	
11	Air pressure relief valves	<ol style="list-style-type: none"> <li>1. Remove air pressure valve from transmission, transfer, front axle, and both rear axles. Refer to Vol. 3, para 8-3, 9-7 and 12-4.</li> </ol> <p style="text-align: center;"><b><u>WARNING</u></b></p> <p style="text-align: center;"><b>Dry cleaning solvent, SD-2, used to clean parts is potentially dangerous to personnel and property. Do not use near open flame or excessive heat. Flash point of solvent is 100°F.</b></p> <ol style="list-style-type: none"> <li>2. Using dry cleaning solvent, clean air pressure relief valves. Dry well using compressed air.</li> <li>3. Replace air pressure relief valves. Refer to Vol 3, para 8-3, 9-7, and 12-4.</li> </ol>	

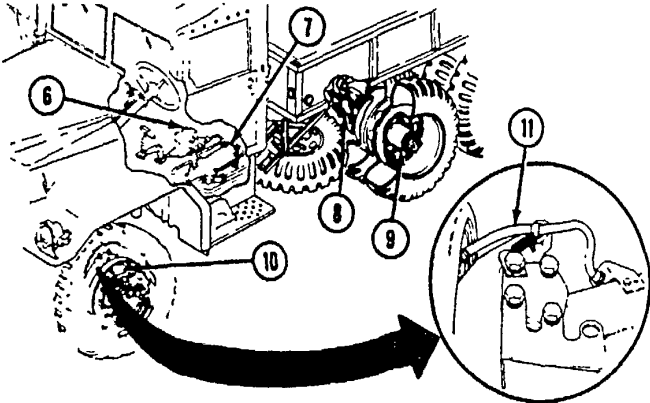
Table 1-1. Organizational Preventive Maintenance Checks and Services Semiannual Schedule - Cont

Item No.	Item To Be Inspected	Procedures Check for and Have Repaired, Replaced, Adjusted as Necessary	
12	Propeller shafts	<p>1. Check that propeller shafts (1 through 4) are not damaged.</p>  <p style="text-align: center;">TA 080488</p> <p>2. Check that all universal joints (5) are not worn. Shake propeller shafts (1 through 4) from side to side and up and down. There should be no noise or looseness in universal joints .</p>	

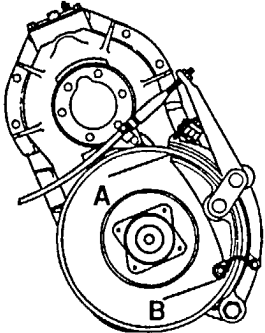
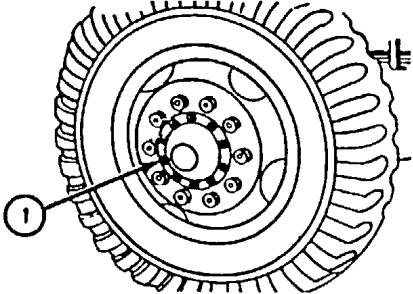

Table 1-1. Organizational Preventive Maintenance Checks and Services Semiannual Schedule - Cont

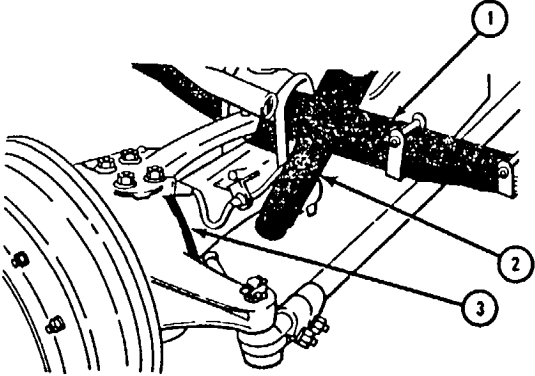
Item No.	Item To Be Inspected	Procedures Check for and Have Repaired, Replaced, Adjusted as Necessary	
12 (cont )		<ol style="list-style-type: none"> <li>3. Using 3/4-inch wrenches, tighten companion mounting nuts (6).</li> <li>4. Using 7/16-inch wrench, tighten universal joint mounting bolts (7) on propeller shafts (2 and 3).</li> </ol>	
13	Rear axles	<ol style="list-style-type: none"> <li>1. Using a torque wrench with 3/4-inch socket, tighten rear axle drive flange bolts (1) to 70 to 80 pound-feet.</li> </ol> <div data-bbox="619 662 1339 1144" style="text-align: center;"> </div> <p style="text-align: right; margin-right: 100px;">TA 080489</p> <ol style="list-style-type: none"> <li>2. Check that springs (2) are not loose or damaged.</li> <li>3. Check that torque rods (3) are not loose or damaged.</li> </ol>	

Table 1-1. Organizational Preventive Maintenance Checks and Services Semiannual Schedule - Cont

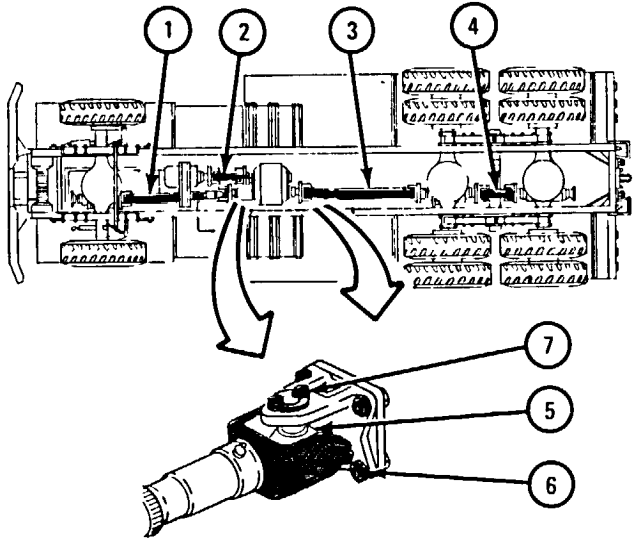
Item No.	Item To Be Inspected	Procedures Check for and Have Repaired, Replaced, Adjusted as Necessary	
14	Brake system	<p>1. Drain water from air reservoirs (1) as follows:</p> <p>(a) Turn petcocks (2) on bottom of air reservoirs (1) to open position.</p>  <p style="text-align: center;">TA 045316</p> <p>(b) Let air and condensation drain off.</p> <p>(c) Turn petcocks (2) to closed position.</p>	

Table 1-1. Organizational Preventive Maintenance Checks and Services Semiannual Schedule - Cont

Item No.	Item To Be Inspected	Procedures Check for and Have Repaired, Replaced, Adjusted as Necessary	
14 (cont)		<p>2. Check that air-hydraulic cylinder (1) is not loose, damaged, or leaking.</p>  <p style="text-align: right;">TA 080586</p>	

Table 1-1. Organizational Preventive Maintenance Checks and Services Semiannual Schedule - Cont

Item No.	Item To Be Inspected	Procedures Check for and Have Repaired, Replaced, Adjusted as Necessary	
14 (cont)		<p>3. Check that all flexible brake hoses (1) are not pinched, worn, or leaking.</p>  <p style="text-align: right;">TA 080587</p> <p>4. Adjust brakes. Refer to Vol 3, chapter 13, para 13-9 and 13-10.</p>	

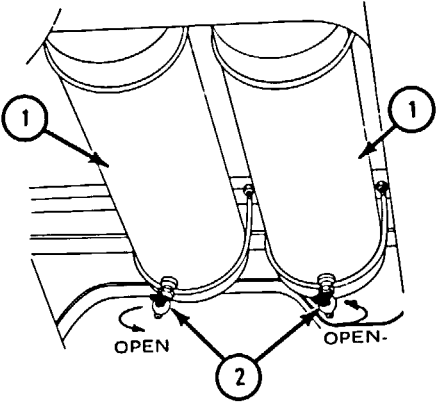
Table 1-1. Organizational Preventive Maintenance Checks and Services Semiannual Schedule - Cont

Item No.	Item To Be Inspected	Procedures Check for and Have Repaired, Replaced, Adjusted as Necessary	
15	Wheel and tire assemblies	<p>Rotate tires (change wheel and tire assemblies from front to rear, side to side, etc.) as shown in following diagram. Match tires to their tread design and degree of wear.</p> <p>Refer to TM 9-1870-1 for specific instructions for matching tires.</p> <p>Check that tread depth of any one tire is less than 1/8-inch; or that one or more tires is not cut to cord.</p> <p>Refer to TM 9-2320-209-10 for removal and replacement procedures for wheel and tire assemblies.</p> <div data-bbox="617 743 1352 1198" style="text-align: center;"> <p>The diagram illustrates a tire rotation schedule for a vehicle with a spare tire. It shows a top-down view of the vehicle's chassis with eight tires: two at the front, two at the rear, and a spare on the right side. Dashed arrows indicate the rotation path: front-left to rear-left, front-right to rear-right, rear-left to front-right, and rear-right to front-left. The spare tire on the right is shown with arrows indicating it should be rotated to the rear-right position. The diagram is labeled 'TA 045626' at the bottom right.</p> </div>	

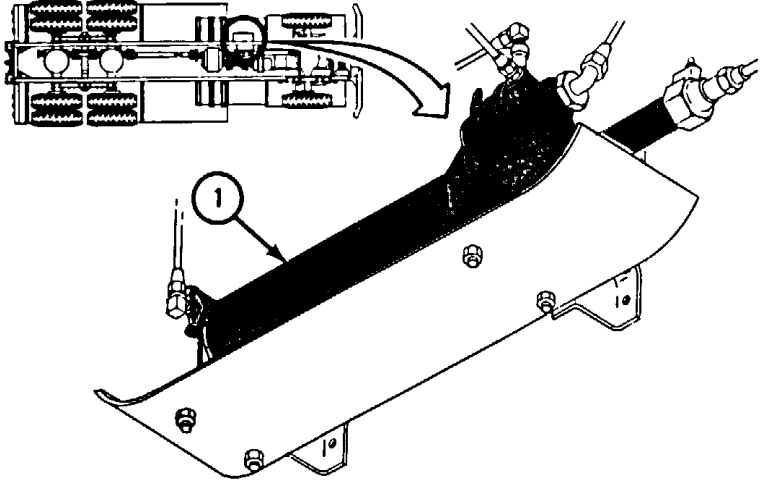
Table 1-1. Organizational Preventive Maintenance Checks and Services Semiannual Schedule - Cont

Item No.	Item To Be Inspected	Procedures Check for and Have Repaired, Replaced, Adjusted as Necessary	
16	Body and frame	<ol style="list-style-type: none"> <li>1. Using a wrench, tighten all body and frame mounting bolts.</li> <li>2. Check that frame members, welds, bolts, and rivets are not cracked, loose, or broken.</li> </ol>	
17	Front winch	<ol style="list-style-type: none"> <li>1. Test adjustment of winch drag brake as follows:               <ol style="list-style-type: none"> <li>(a) Pull 3 to 4 feet of winch cable (1) off drum (2). Refer to TM 9-2320-209-10.</li> </ol> </li> </ol> <div data-bbox="611 818 1346 1182" style="text-align: center;"> </div> <p style="text-align: center;">TA 080490</p> <ol style="list-style-type: none"> <li>(b) Stop pulling on cable (1) and check that drum (2) stops turning right away.</li> </ol>	

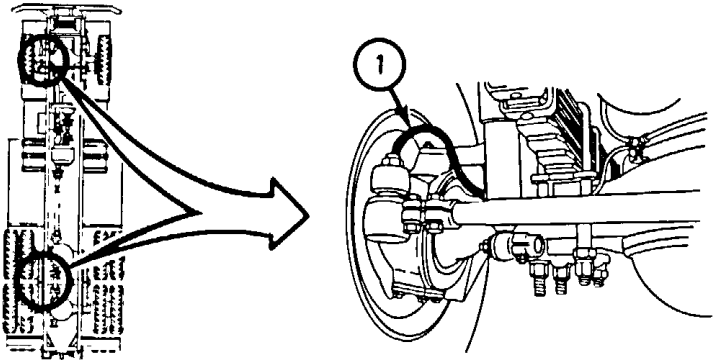
Table 1-1. Organizational Preventive Maintenance Checks and Services Semiannual Schedule - Cont

Item No.	Item To Be Inspected	Procedures Check for and Have Repaired, Replaced, Adjusted as Necessary	
17 (cont)		<p>(c) If drum (2) does not stop turning right away, turn adjusting screw (3) a little to the right. Test drag brake again, following steps (a) and (b).</p> <p>(d) When drag brake is properly adjusted, unwind rest of cable (1). Check that cable is not kinked, and does not have broken wires or broken/loose clamps.</p> <p>(e) Wind cable (1) back on drum (2). Refer to TM 9-2320-209-10.</p>	
18	Air cleaner system	<p>2. Test that winch automatic brake will hold a load on a hill. Refer to Vol 3, chapter 19, para 19-3 for test and adjustment procedures.</p> <p>1. Open hood. Refer to TM 9-2320-209-10.</p> <p>2. Check that air cleaner (1) and air intake tubes (2 and 3) are not loose or damaged.</p> <div data-bbox="779 873 1220 1339" style="text-align: center;"> <p>The diagram shows a top-down view of an engine compartment. Callout 1 points to a large, dark, cylindrical air filter. Callout 2 points to a curved air intake tube on the left side. Callout 3 points to another curved air intake tube on the right side. Callout 4 points to a circular component, likely a pressure cap or filter, located at the top of the engine compartment.</p> </div>	

TA 080491

Table 1-1. Organizational Preventive Maintenance Checks and Services Semiannual Schedule - Cont

Item No.	Item To Be Inspected	Procedures Check for and Have Repaired, Replaced, Adjusted as Necessary	
18 (cont)		3. Check that air cleaner indicator tube (4) is not bent or kinked.	
19	Engine crankcase breather assembly	<p>Clean engine crankcase breather assembly (1). Refer to Vol 3, chapter 2, para 2-6.</p>  <p style="text-align: right;">TA 080492</p>	
20	Manifold preheater	Check that manifold preheater tubing (2) and wiring (3) are not loose or damaged.	



Table 1-1. Organizational Preventive Maintenance Checks and Services Semiannual Schedule - Cont

Item No.	Item To Be Inspected	Procedures Check for and Have Repaired, Replaced, Adjusted as Necessary	
21	Fuel filters and fuel lines	<p>Check that fuel filters (1, 2, and 3) and all fuel lines (4) are not leaking, loose, or damaged. Refer to Vol 2, chapter 15, figs. 15-1 through 15-5 for locations of fuel lines.</p>  <p style="text-align: right;">TA 080493</p>	
22	Oil filters	<ol style="list-style-type: none"> <li>1. Check that oil filters (5) are not leaking.</li> <li>2. Close hood. Refer to TM 9-2320-209-10.</li> </ol>	

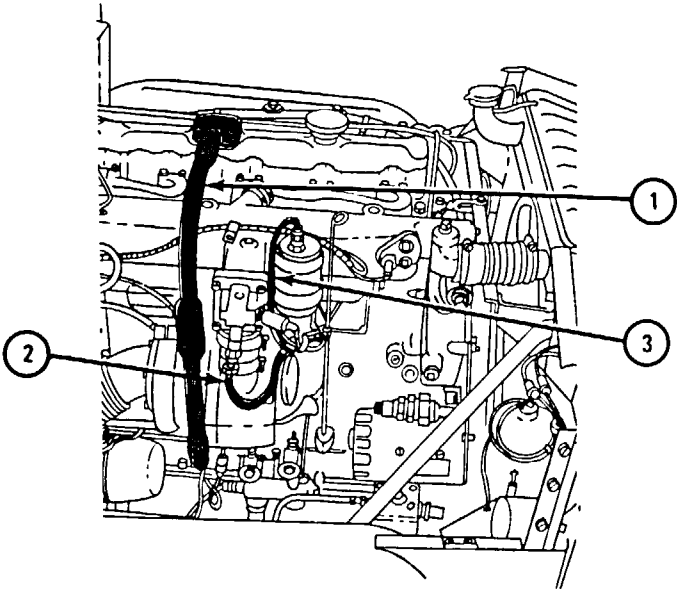
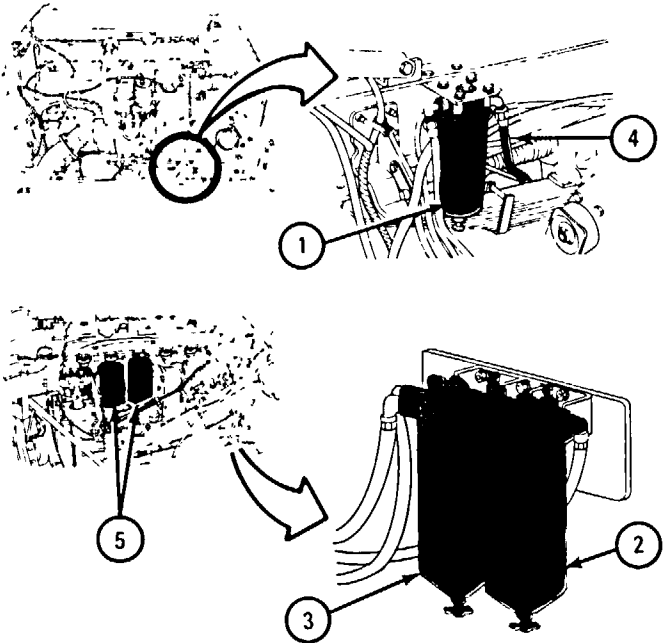
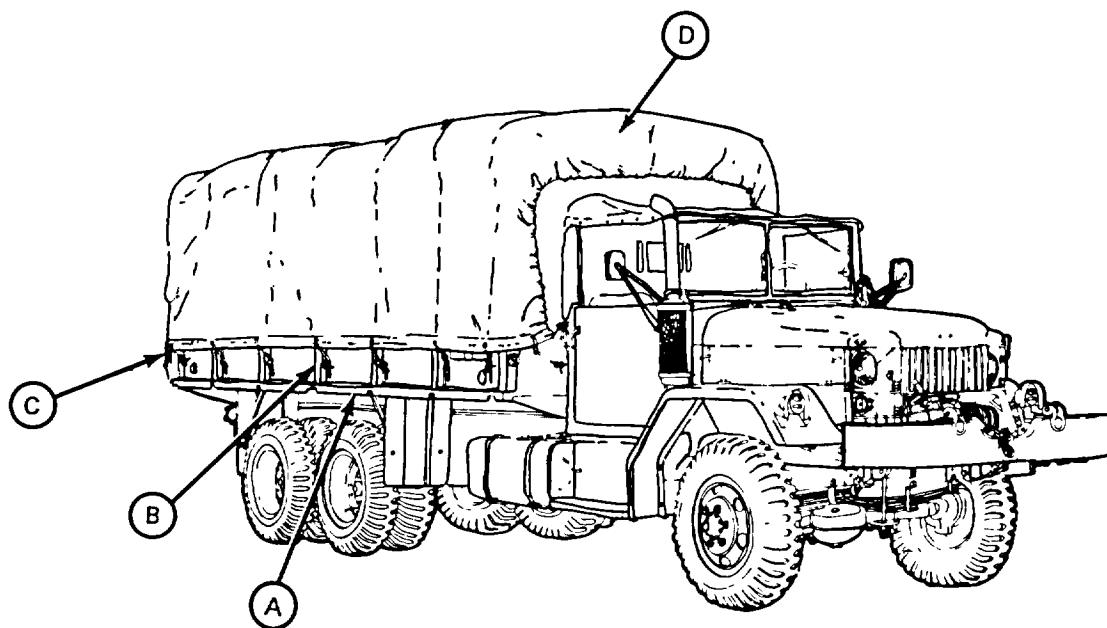

TA 045629

A. Bed plate  
B. Side panels

C. Tailgate  
D. Tarpaulin

*Figure 1-2. M35A1, M35A2, M35A2C, and M36A2 Cargo Trucks,  
Preventive Maintenance Locators.*

Table 1-2. Organizational Preventive Maintenance Checks and Services Semiannual Schedule for M35A1, M35A2, M35A2C, and M36A2 Cargo Trucks

Item No.	Item To Be Inspected	Procedures Check for and Have Repaired, Replaced, Adjusted as Necessary	
1	Cargo body	<ol style="list-style-type: none"> <li>1. Check that bed plate, side panels, and tail-gate are not loose, warped, rusted, or otherwise damaged.</li> <li>2. Using a wrench, tighten all assembly and mounting bolts.</li> <li>3. Check that body tarpaulin fits properly and is not torn.</li> </ol>	

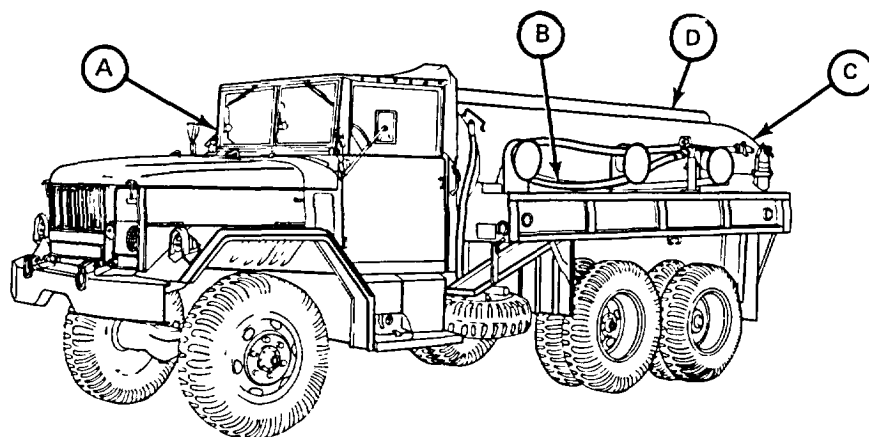

TA 045630

- |                          |                   |
|--------------------------|-------------------|
| A. Fire extinguisher     | D. Manhole covers |
| B. Dispenser line        | Filler caps       |
| C. Fire extinguisher     |                   |
| Suction hoses            |                   |
| Fuel pump system         |                   |
| Gravity discharge system |                   |

Figure 1-3. M49A1C and M49A2C Fuel Tank Trucks,  
Preventive Maintenance Locators.

Table 1-3. Organizational Preventive Maintenance Checks and Services Semiannual Schedule for M49A1C and M49A2C Fuel Tank Trucks

Item No.	Item To Be Inspected	Procedures Check for and Have Repaired, Replaced, Adjusted as Necessary	
1	Fire extinguishers	<p>Check that seals on fire extinguishers (1, 2, and 3) are not broken.</p>  <p style="text-align: right;">TA 080494</p>	
2	Dispenser line assembly	<p>Check that dispenser line assembly (4) is not missing or damaged.</p>	

Table 1-3. Organizational Preventive Maintenance Checks and Services Semiannual Schedule for M49A1C and M49A2C Fuel Tank Trucks - Cont

Item No.	Item To Be Inspected	Procedures Check for and Have Repaired, Replaced, Adjusted as Necessary	
3	Suction hoses	<p>1. Open both hose compartment doors (1).</p>  <p style="text-align: right;">TA 080495</p> <p>2. Check that two suction hoses (2) are not missing or damaged.</p> <p>3. Close hose compartment doors (1).</p>	
4	Fuel pump system and gravity discharge system	<p>1. Open both rear compartment doors (3).</p> <p>2. Check that all pipes (4), couplings (5), and caps (6) are not loose, damaged, or leaking.</p> <p style="text-align: center;"><b>NOTE</b></p> <p style="text-align: center;"><b>Refer to TM 9-2320-209-10 for operating procedures when doing the following checks.</b></p>	

Table 1-3. Organizational Preventive Maintenance Checks and Services Semiannual Schedule for M49A1C and M49A2C Fuel Tank Trucks - Cont

Item No.	Item To Be Inspected	Procedures Check for and Have Repaired, Replaced, Adjusted as Necessary	
4 (cont)		<p>3. Pump enough fuel from one compartment to another to make sure that fuel pump system works properly. Do this for all compartments (three on M49A1C, two on M49A2C). Check that there are no leaks or unusual noise or vibrations.</p> <p>4. (a) Gravity discharge fuel from one compartment to a clean container. Empty enough fuel to check that gravity discharge system works properly and does not leak.</p> <p>(b) Pump fuel back into compartment.</p> <p>5. Close rear compartment doors (3).</p>	

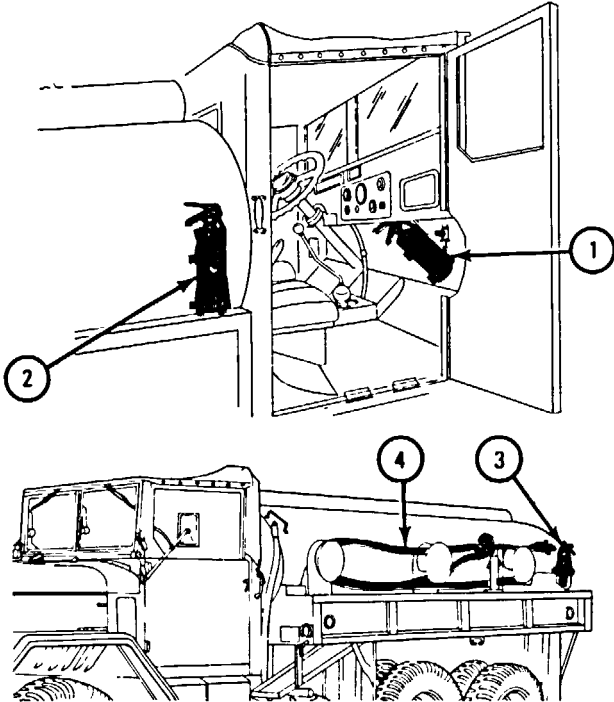
Table 1-3. Organizational Preventive Maintenance Checks and Services Semiannual Schedule for M49A1C and M49A2C Fuel Tank Trucks - Cont

Item No.	Item To Be Inspected	Procedures Check for and Have Repaired, Replaced, Adjusted as Necessary	
5	Tank body	<p>1. Check that manhole covers (1) and filler caps (2) seal properly and are not damaged. Check that chains (3) and locks (4) are not damaged.</p>  <p style="text-align: right;">TA 080496</p> <p>2. Check that tank body is not leaking and that paint is not scraped.</p>	
6	Water segregator filter assembly	Put in new filter elements and go-no-go fuses at every other semiannual check. Refer to Vol 3, chapter 18, para 18-42.	

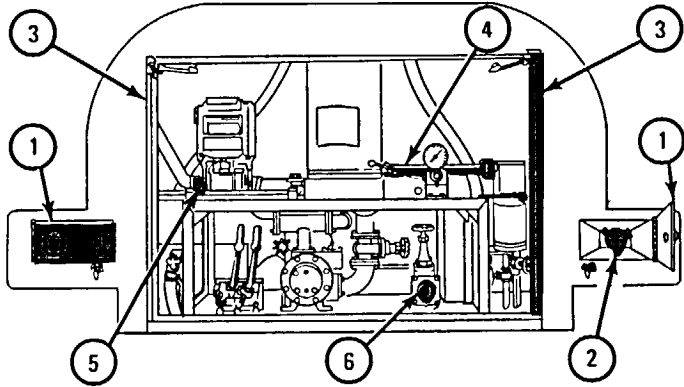
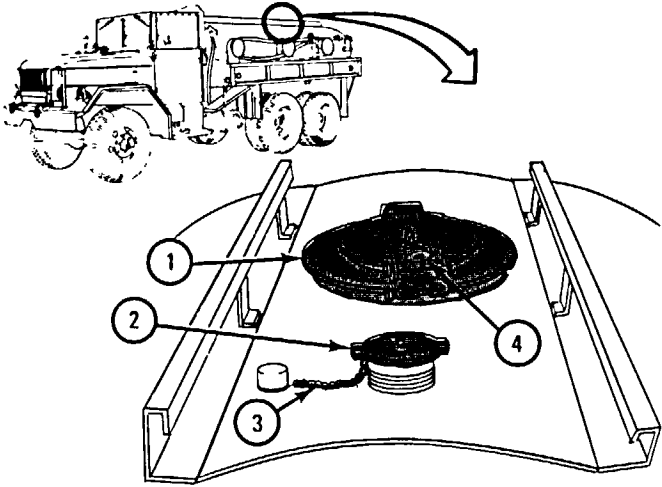

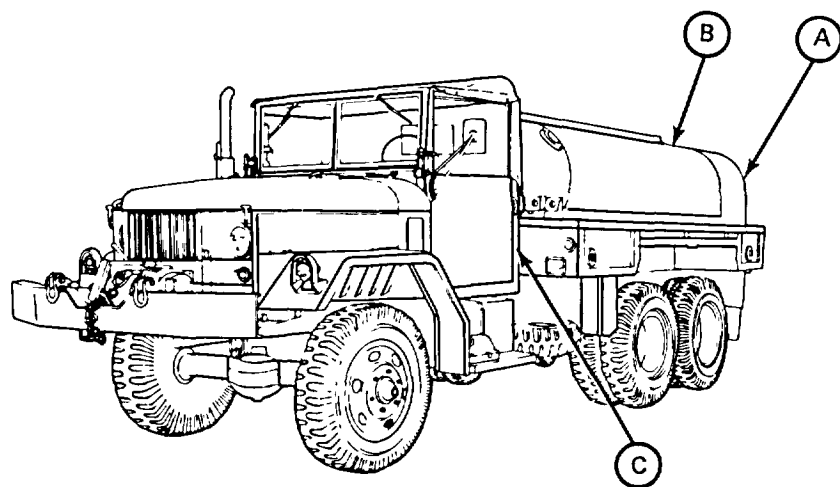

TA 045631

- |   |   |
|---|---|
| <p>A. Nozzle coupling, hoses<br/>Water pump system<br/>Gravity discharge system</p> | <p>C. Exhaust bypass valve control (in cab)<br/>Exhaust bypass fording valve<br/>(M50A2 only - between cab and<br/>tank body)</p> |
| <p>B. Manhole covers<br/>Filler caps</p>  |   |

*Figure 1-4. M50A1, M50A2, and M50A3 Water Tank Trucks,  
Preventive Maintenance Locators*

Table 1-4. Organizational Preventive Maintenance Checks and Services Semiannual Schedule for M50A1, M50A2, and M50A3 Water Tank Trucks

Item No.	Item To Be Inspected	Procedures Check for and Have Repaired, Replaced, Adjusted as Necessary	
1	Nozzle, coupling, cap, and hoses	<p>1. Open both rear compartment doors (1).</p>  <p style="text-align: right;">TA 080497</p>	
2	Water pump system and gravity discharge system	<p>2. Check that dispenser nozzle (2), Y coupling (3), gate valve caps (4), and hoses (5) are not missing or damaged.</p> <p style="text-align: center;"><b>NOTE</b></p> <p style="text-align: center;"><b>Refer to TM 9-2320-209-10 for operating procedures when doing the following checks.</b></p>	

Table 1-4. Organizational Preventive Maintenance Checks and Services Semiannual Schedule for M50A1, M50A2, and M50A3 Water Tank Trucks - Cont

Item No.	Item To Be Inspected	Procedures Check for and Have Repaired, Replaced, Adjusted as Necessary	
2		<ol style="list-style-type: none"> <li>1. Pump enough water from one compartment to another to make sure that water pump system works properly. Do this for both compartments. Check that there are no leaks or unusual noise or vibration.                             <ol style="list-style-type: none"> <li>(a) Gravity discharge water from one compartment to a clean container. Empty enough water to check that gravity discharge system works properly and does not leak.</li> <li>(b) Pump water back into compartment.</li> </ol> </li> <li>2. Close rear compartment doors (1).</li> </ol>	
3	Tank body	<ol style="list-style-type: none"> <li>1. Check that manhole covers (1) and filler caps (2) seal properly and are not damaged. Check that locks (3) are not damaged.</li> </ol>  <p style="text-align: right; font-size: small;">TA 080498</p>	

Table 1-4. Organizational Preventive Maintenance Checks and Services Semiannual Schedule for M50A1, M50A2, and M50A3 Water Tank Trucks - Cont

Item No.	Item To Be Inspected	Procedures Check for and Have Repaired, Replaced, Adjusted as Necessary	
3 (cont)		2. Check that tank body is not leaking and that paint is not scraped.	
4	Exhaust bypass system (M50A2)	<p style="text-align: center;"><b>CAUTION</b></p> <p style="text-align: center;"><b>Exhaust bypass system will overheat tank body if there is less than 10 inches of water in either compartment. Do this check as quickly as possible if water level is lower than 10 inches.</b></p> <p>Check exhaust bypass system for proper operation as follows:</p> <ol style="list-style-type: none"> <li>1. Start engine. Refer to TM 9-2320-209-10.</li> <li>2. Pull exhaust bypass valve control (1) to out position.</li> </ol> <div style="text-align: center;">  </div> <p style="text-align: right;">TA 080499</p>	

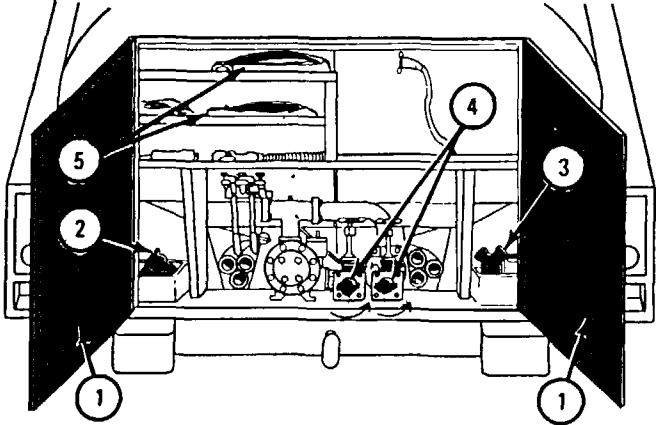
Table 1-4. Organizational Preventive Maintenance Checks and Services Semiannual Schedule for M50A1, M50A2, and M50A3 Water Tank Trucks - Cont

Item No.	Item To Be Inspected	Procedures Check for and Have Repaired, Replaced, Adjusted as Necessary	
4 (cont)		<ol style="list-style-type: none"> <li>3. Check that exhaust gases are bypassing exhaust system and are coming out at rear of tank body.</li> <li>4. Turn exhaust bypass fording valve handle (2) all the way to right. Check that exhaust gases have stopped coming out at rear of tank body.</li> <li>5. Turn exhaust bypass fording valve handle (2) all the way to left.</li> <li>6. Push exhaust bypass valve control (1) to in position.</li> <li>7. Stop engine. Refer to TM 9-2320-209-10.</li> </ol>	
5	Exhaust bypass system (M50A3)	<p style="text-align: center;"><b>CAUTION</b></p> <p style="text-align: center;"><b>Exhaust bypass system will overheat tank body if there is less than 10 inches of water in either compartment. Do this check as quickly as possible, if water level is lower than 10 inches.</b></p> <p>Check exhaust bypass system for proper operation as follows:</p> <ol style="list-style-type: none"> <li>1. Start engine. Refer to TM 9-2320-209-10.</li> <li>2. Pull exhaust bypass valve control (1) to out position.</li> </ol>	

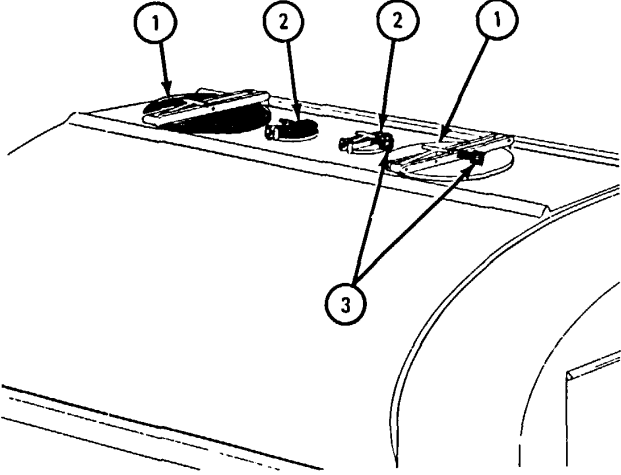
Table 1-4. Organizational Preventive Maintenance Checks and Services Semiannual Schedule for M50A1, M50A2, and M50A3 Water Tank Trucks - Cont

Item No.	Item To Be Inspected	Procedures Check for and Have Repaired, Replaced, Adjusted as Necessary	
5 (cont)		 <p style="text-align: center;">TA 080500</p> <ol style="list-style-type: none"> <li>3. Check that exhaust gases are bypassing exhaust system and are coming out at rear of tank body.</li> <li>4. Push exhaust bypass valve control (1) to in position.</li> <li>5. Stop engine. Refer to TM 9-2320-209-10.</li> </ol>	

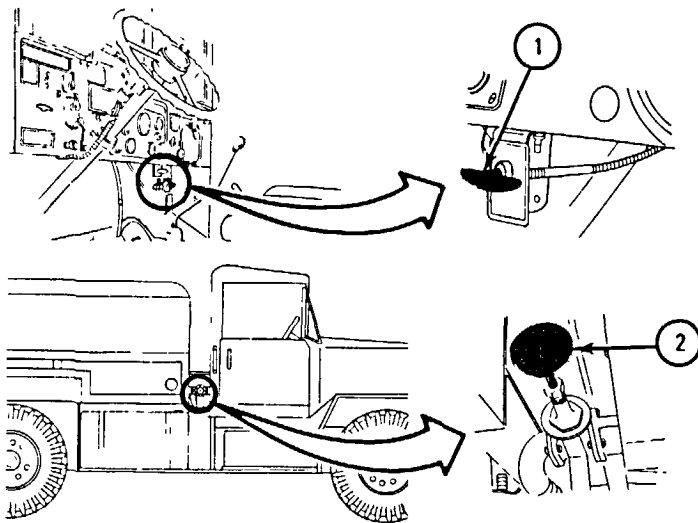
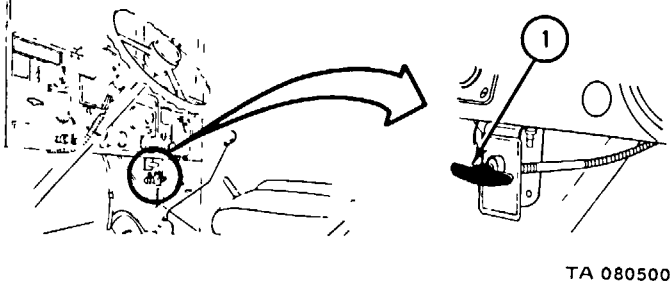
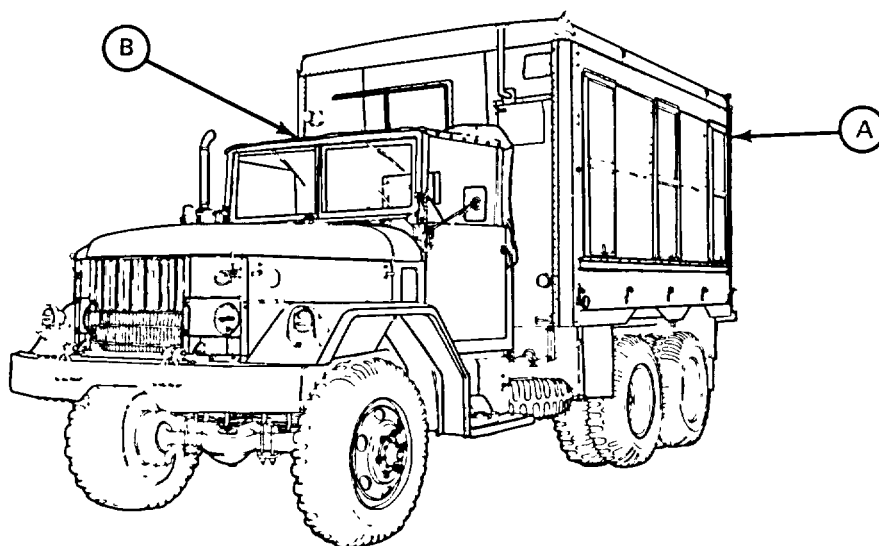

TA 045633

- A. Van body and hardware  
Van electrical system
- B. Heater fuel pump

*Figure 1-5. M109A2, M109A3, M185A2, and M185A3 Shop Van Trucks,  
Preventive Maintenance Locators.*

Table 1-5. Organizational Preventive Maintenance Checks and Services Semiannual Schedule for M109A2, M109A3, M185A2, and M185A3 Shop Van Trucks

Item No.	Item To Be Inspected	Procedures Check for and Have Repaired, Replaced, Adjusted as Necessary	
1	Van body and hardware	<p style="text-align: center;"><b>NOTE</b></p> <p style="text-align: center;"><b>Refer to TM 9-2320-209-10 for operating procedures when doing the following checks.</b></p> <ol style="list-style-type: none"> <li>1. Check that all blackout panels (1) slide freely and are not damaged.</li> </ol> <div style="text-align: center;">  <p style="text-align: center;">TA 080501</p> </div> <ol style="list-style-type: none"> <li>2. Check that access ladder (2) and mounting hardware (3) are not damaged. Put access ladder in place to enter van body.</li> <li>3. Open doors (4 and 5). Check that doors and door locks, latches, and hinges are not damaged.</li> </ol>	



Table 1-5. Organizational Preventive Maintenance Checks and Services Semiannual Schedule for M109A2, M109A3, M185A2, and M185A3 Shop Van Trucks - Cont

Item No.	Item To Be Inspected	Procedures Check for and Have Repaired, Replaced, Adjusted as Necessary	
<p>1 (cont)</p> <p>2</p>	<p>Van electrical system</p>	<p>4. Using a wrench, tighten all mounting bolts and connections.</p> <p>1. Check exhaust blower (1) for proper operation.</p>  <p style="text-align: center;">TA 080502</p> <p>2. Check all other AC and DC switches, circuits, and equipment for proper operation.</p> <p>3. Check that all exposed wiring is not worn, frayed, or otherwise damaged.</p>	

Table 1-5. Organizational Preventive Maintenance Checks and Services Semiannual Schedule for M109A2, M109A3, M185A2, and M185A3 Shop Van Trucks - Cont

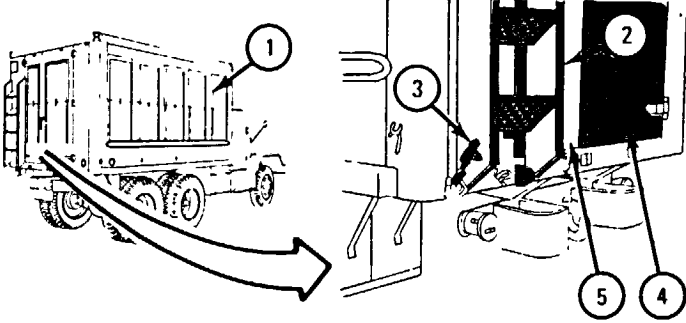
Item No.	Item To Be Inspected	Procedures Check for and Have Repaired, Replaced, Adjusted as Necessary	
3	Van body	<p>1. Check that van body personnel heaters (1 and 2), electrical connections (3 and 4), fuel connections (5 and 6) are not leaking, loose, or damaged.</p>  <p style="text-align: right;">TA 080503</p>	

Table 1-5. Organizational Preventive Maintenance Checks and Services Semiannual Schedule for M109A2, M109A3, M185A2, and M185A3 Shop Van Trucks - Cont

Item No.	Item To Be Inspected	Procedures Check for and Have Repaired, Replaced, Adjusted as Necessary	
3 (cont)		<p>2. Check that heater fuel pump (1) and fuel lines (2 and 3) are not leaking, loose, or damaged. (Fuel pump is mounted outside front wall of van body.)</p>  <p style="text-align: right;">TA 080504</p> <p>3. Close rear doors and put access ladder back in place.</p>	

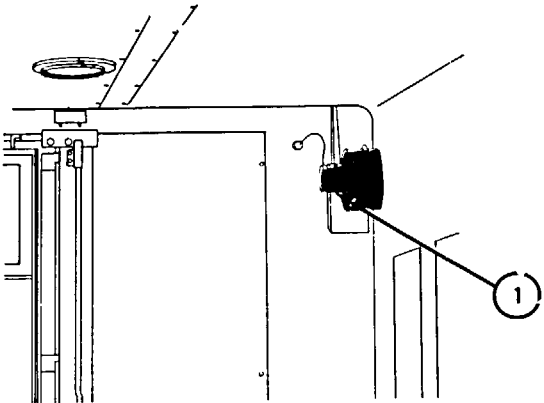

TA 045634

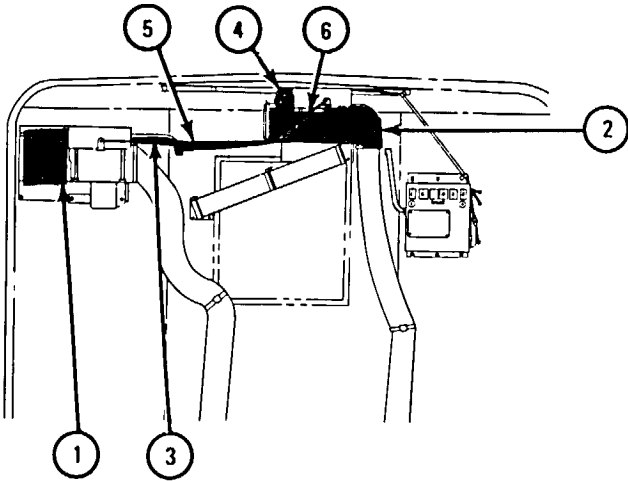
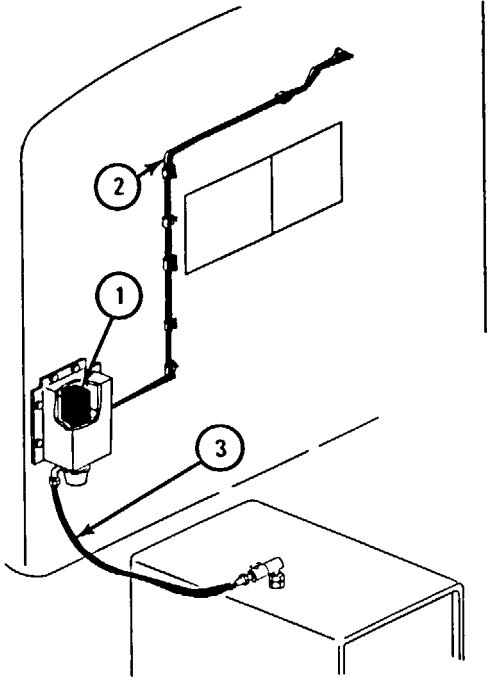
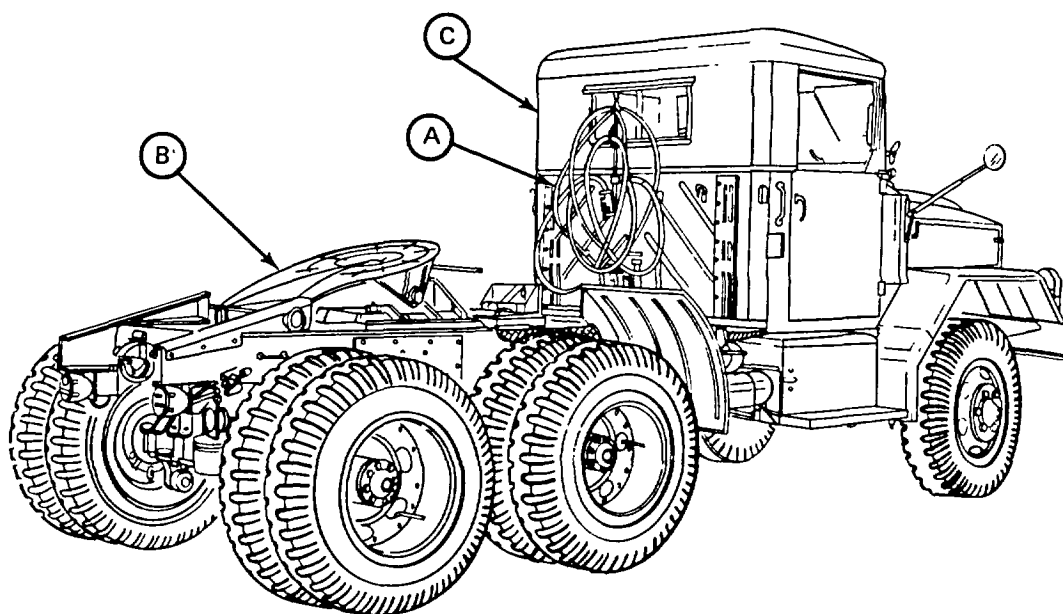
A. Airbrake hoses

Electrical cable and connector

B. Fifth wheel

C. Airbrake hand control valve

Figure 1-6. M275A1 and M275A2 Tractor Truck,  
Preventive Maintenance Locators.

Table 1-6. Organizational Preventive Maintenance Checks and Services Semiannual Schedule for M275A1 and M275A2 Tractor Trucks

Item No.	Item To Be Inspected	Procedures Check for and Have Repaired, Replaced, Adjusted as Necessary	
1	Airbrake hoses and electrical cable	<p>Check that airbrake hoses (1) and electrical cable (2) are not loose, damaged, or worn.</p>  <p style="text-align: right;">TA 045339</p>	
2	Fifth wheel and airbrake hand control valve	<p>1. Check that face of fifth wheel (1) is not worn, cracked, or otherwise damaged.</p>	

Table 1-6. Organizational Preventive Maintenance Checks and Services Semiannual Schedule for M275A1 and M275A2 Tractor Trucks - Cont

Item No.	Item To Be Inspected	Procedures Check for and Have Repaired, Replaced, Adjusted as Necessary	
2 (cont)		<div style="text-align: center;">  <p>TA 045640</p> </div> <ol style="list-style-type: none"> <li>2. Check that fifth wheel (1) does not bind at pivot points as follows:             <ol style="list-style-type: none"> <li>(a) Push up and pull down at point (A) to check that shaft (2) does not bind.</li> <li>(b) Push up and pull down at (B) to check that shaft (3) does not bind.</li> </ol> </li>   <li>3.             <ol style="list-style-type: none"> <li>(a) Couple tractor to a trailer, and check that fifth wheel (1) couples properly. Refer to TM 9-2320-209-10.</li> <li>(b) Hook up airbrake hoses and check airbrake hand control valve for proper operation. Refer to TM 9-2320-209-10.</li> <li>(c) Unhook airbrake hoses and uncouple tractor from trailer. Check that fifth wheel (1) uncouples properly. Refer to TM 9-2320-209-10.</li> </ol> </li>   <li>4. Using a wrench, tighten all mounting bolts.</li> </ol>	

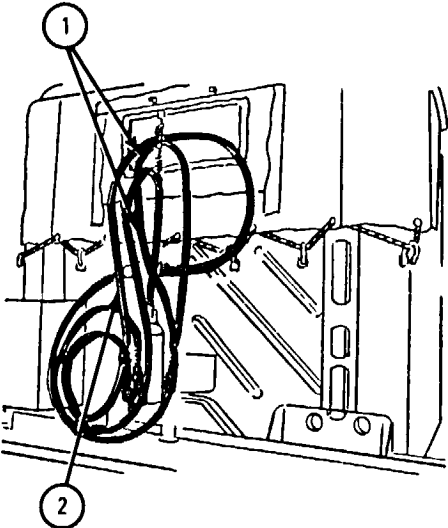
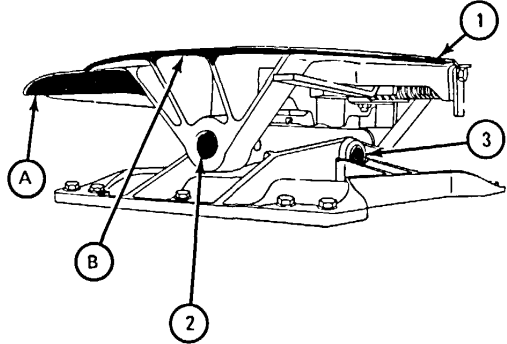
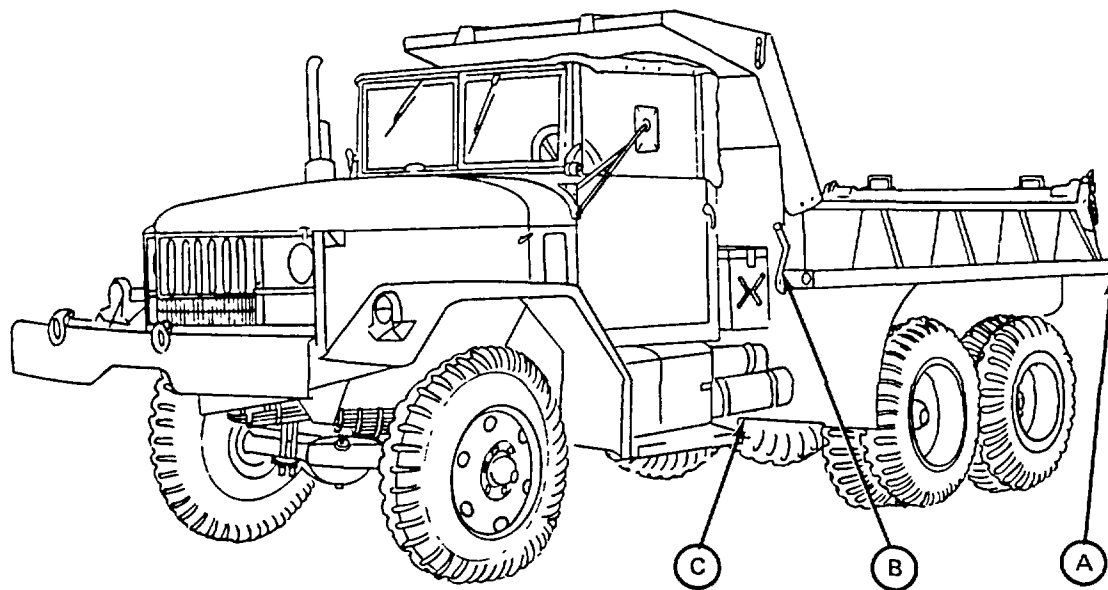

TA 045635

- A. Dump body
- B. Tailgate control lever
- C. Hydraulic system

Figure 1-7. M342A2 Dump Truck, Preventive Maintenance Locators.

Table 1-7. Organizational Preventive Maintenance Checks and Services Semiannual Schedule for M342A2 Dump Truck

Item No.	Item To Be Inspected	Procedures Check for and Have Repaired, Replaced, Adjusted as Necessary	
1	Dump body	<ol style="list-style-type: none"> <li>1. Check that dump body is aligned with truck frame.</li> <li>2. Check that tailgate control lever rod hand (1) locks and unlocks tailgate lower latch (2).</li> </ol> <div style="text-align: center;">  <p>TA 080527</p> </div>	
2	Hydraulic hoist system	<ol style="list-style-type: none"> <li>3. Using a wrench, tighten all mounting bolts.</li> <li>1. Check that hydraulic hoist pump (1), control valve (2), reservoir (3), four control valve hoses (4), and two cylinders (5) are not leaking, loose, or damaged.</li> </ol>	



Table 1-7. Organizational Preventive Maintenance Checks and Services Semiannual Schedule for M342A2 Dump Truck - Cont

Item No.	Item To Be Inspected	Procedures Check for and Have Repaired, Replaced, Adjusted as Necessary	
2 (cont)		 <p style="text-align: right;">TA 080505</p> <ol style="list-style-type: none"> <li>2. Raise dump body. Check that body goes up smoothly and stays in raised position. Refer to TM 9-2320-209-10.</li> <li>3. Lower dump body. Check that dump body comes down smoothly to fully lowered position. Refer to TM 9-2320-209-10.</li> </ol>	

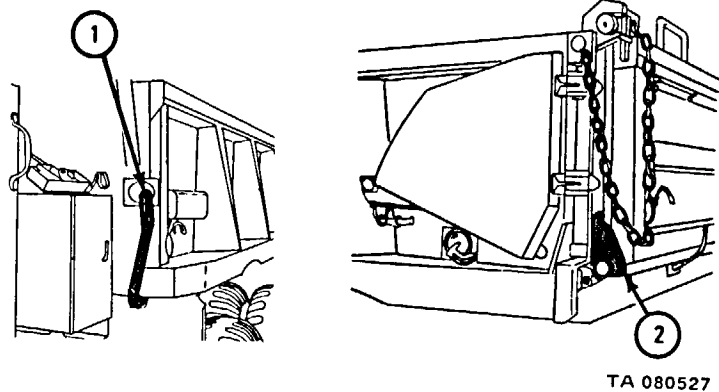
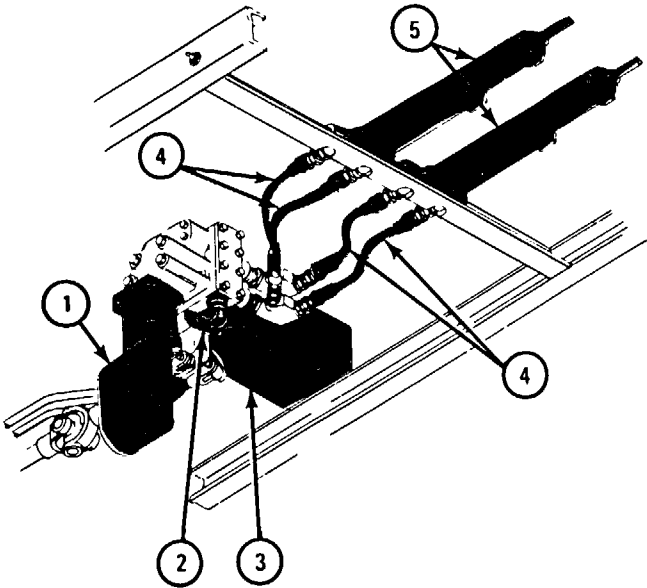
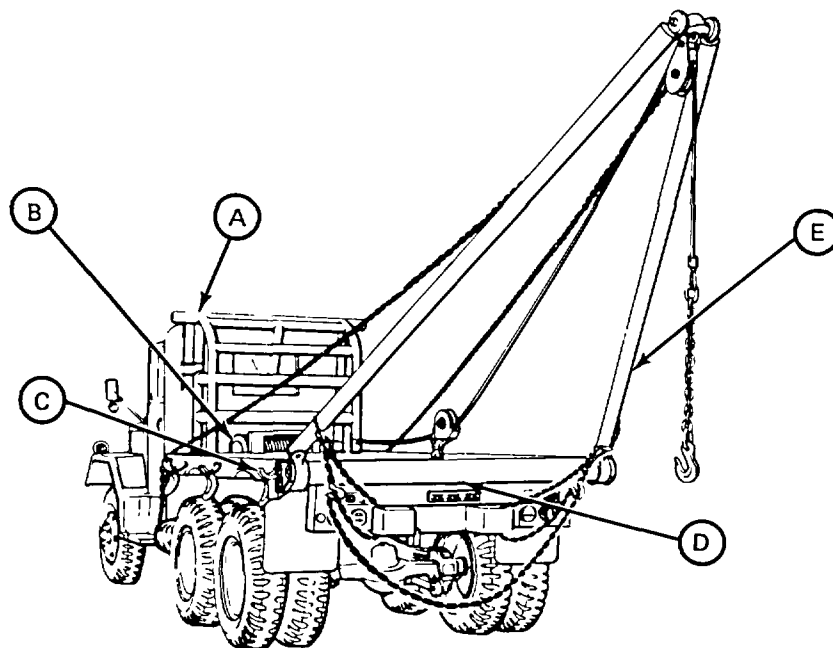

TA 045636

- A. Winch and cab protector
- B. Rear winch
- C. Stiff leg jacks
- D. Tailboard roller assembly
- E. A-frame assembly

Figure 1-8. M756A2 Pipeline Construction Truck, Preventive Maintenance Locators.

Table 1-8. Organizational Preventive Maintenance Checks and Services Semiannual Schedule for M756A2 Pipeline Construction Truck

Item No.	Item To Be Inspected	Procedures Check for and Have Repaired, Replaced, Adjusted as Necessary	
1	Winch and cab protector	<p>Check that winch and cab protector (1) is not damaged. Check that there are no broken welds or loose/missing bolts.</p>  <p style="text-align: right;">TA 080506</p>	
2	Rear winch	<ol style="list-style-type: none"> <li>1. Check that winch (2) is not leaking oil.</li> <li>2. Check that winch parts and mounting bolts (3) are not loose/missing.</li> </ol>	

Table 1-8. Organizational Preventive Maintenance Checks and Services Semiannual Schedule for M756A2 Pipeline Construction Truck - Cont

Item No.	Item To Be Inspected	Procedures Check for and Have Repaired, Replaced, Adjusted as Necessary	
2 (cont)		<p>3. Test adjustment of winch drag brake as follows:</p> <p>(a) Pull 3 to 4 feet of cable (1) off drum (2). Refer to TM 9-2320-209-10.</p>  <p style="text-align: right;">TA 080507</p> <p>(b) Stop pulling on cable (1) and check that drum (2) stops turning right away.</p> <p>(c) If drum (2) does not stop turning right away, turn adjusting screw (3) 1/2-turn to the right. Test drag brake again, following steps (a) and (b).</p>	

Table 1-8. Organizational Preventive Maintenance Checks and Services Semiannual Schedule for M756A2 Pipeline Construction Truck - Cont

Item No.	Item To Be Inspected	Procedures Check for and Have Repaired, Replaced, Adjusted as Necessary	
2 (cont)		<p>(d) When drag brake is properly adjusted, unwind rest of cable (1). Refer to TM 9-2320-209-10.</p> <p>4. Check that cable (1) is not kinked, does not have broken wires, or broken/loose clamps.</p> <p>5. Check that drum (2) is not cracked, and does not have broken welds.</p> <p>6. Wind cable back on drum. Refer to TM 9-2320-209-10.</p> <p>7. Check adjustment of winch automatic brake. Automatic brake should hold a 1,000 pound load without slipping. Refer to Vol 3, chapter 19, para 19-3 for test and adjustment procedures.</p>	

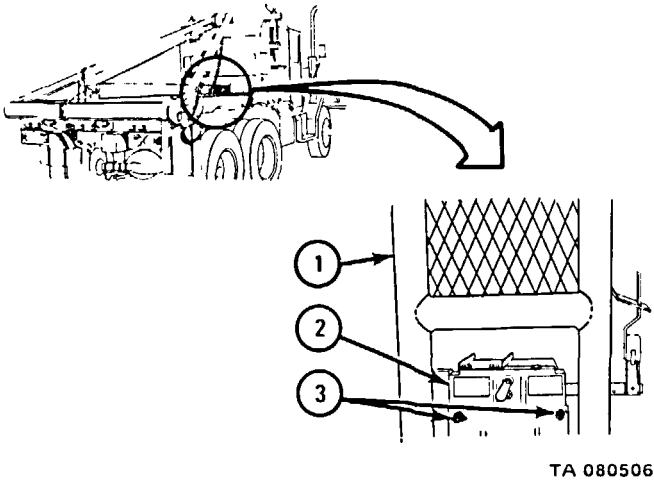
Table 1-8. Organizational Preventive Maintenance Checks and Services Semiannual Schedule for M756A2 Pipeline Construction Truck - Cont

Item No.	Item To Be Inspected	Procedures Check for and Have Repaired, Replaced, Adjusted as Necessary	
3	Body	<p>1. Check that body subframe (1) is not cracked, broken, and does not have broken welds. Check that subframe is aligned with truck chassis.</p>  <p>The diagram consists of two parts. The left part is a side-view sketch of the truck's body assembly with callouts: (6) points to a rack or seat hardware, (3) points to a floorboard, and (5) points to a body panel. The right part is a close-up sketch of the subframe (1) and mounting sill (2) above a tire, with callouts (1) and (2) pointing to these specific components. A large arrow points from the side view to the close-up view.</p> <p style="text-align: right;">TA 080508</p> <p>2. Check that mounting sills (2) and floorboards (3) are not cracked, split, rotten, and do not have loose or missing hardware.</p> <p>3. Check that tailgate (4) and body panels (5) are not bent, broken, and do not have broken welds.</p> <p>4. Check that hardware for racks and troop seats (6) is not loose or missing.</p>	

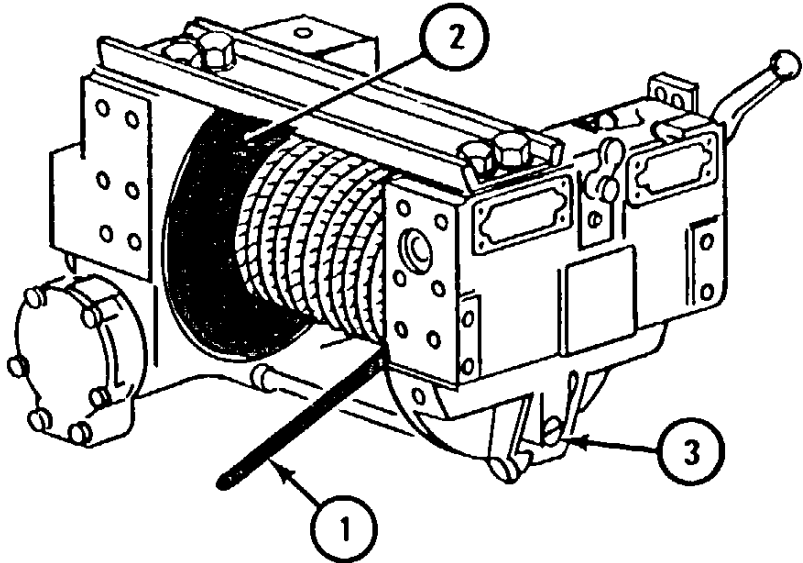
Table 1-8. Organizational Preventive Maintenance Checks and Services Semiannual Schedule for M756A2 Pipeline Construction Truck - Cont

Item No.	Item To Be Inspected	Procedures Check for and Have Repaired, Replaced, Adjusted as Necessary	
4	Stiff leg jacks	<p>1. Check that stiff leg jacks (1) are not broken, bent, or missing mounting pins (2).</p>  <p style="text-align: center;">TA 080509</p> <p>2. Check stiff leg jacks (1) for proper operation. Refer to TM 9-2320-209-10.</p>	

Table 1-8. Organizational Preventive Maintenance Checks and Services Semiannual Schedule for M756A2 Pipeline Construction Truck - Cont

Item No.	Item To Be Inspected	Procedures Check for and Have Repaired, Replaced, Adjusted as Necessary	
5	Tailboard roller assembly	<p>1. Check that tailboard roller (1) does not bind by turning it two or three turns.</p>  <p style="text-align: right;">TA 080510</p> <p>2. Check that tailboard roller (1) end play (movement from side to side) is between 0 and 1/4-inch.</p> <p>3. Check that clearance between tailboard roller (1) and support rollers (2) is between 0 and 1/4-inch.</p>	

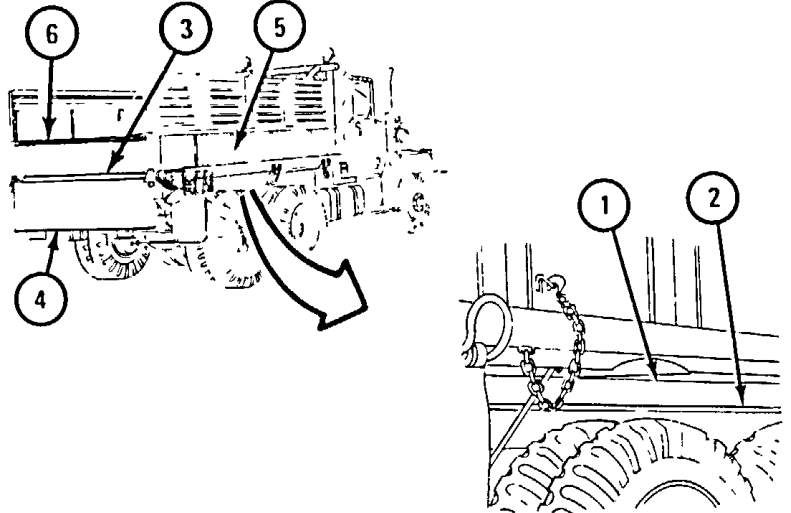

Table 1-8. Organizational Preventive Maintenance Checks and Services Semiannual Schedule for M756A2 Pipeline Construction Truck - Cont

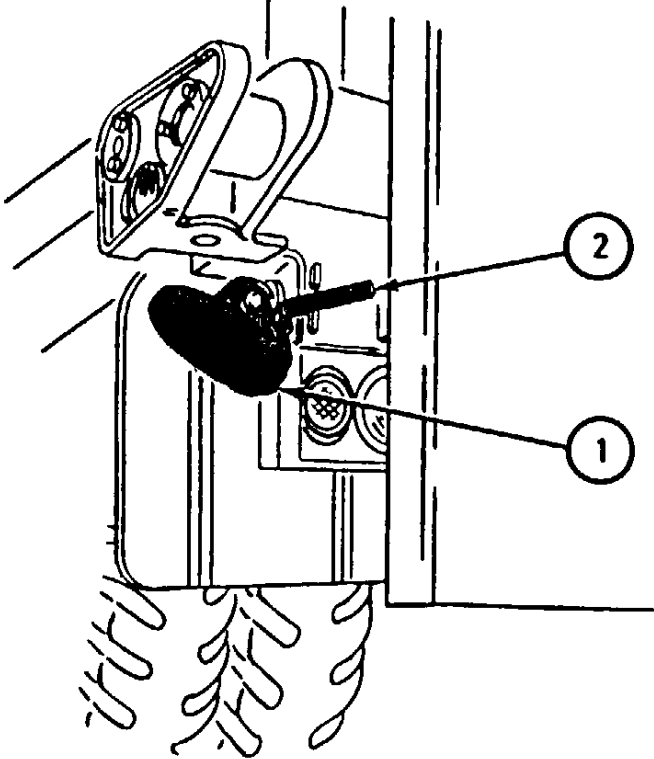
Item No.	Item To Be Inspected	Procedures Check for and Have Repaired, Replaced, Adjusted as Necessary	
6	A-frame assembly	<p>1. Check that boom chains (1), gin poles (2), and trunnion (3) are not damaged.</p>  <p style="text-align: center;">TA 080511</p> <p>2. Put gin poles (2) in rear operating position and take out trunnion (3). Refer to TM 9-2320-209-10.</p>	

Table 1-8. Organizational Preventive Maintenance Checks and Services Semiannual Schedule for M756A2 Pipeline Construction Truck - Cont

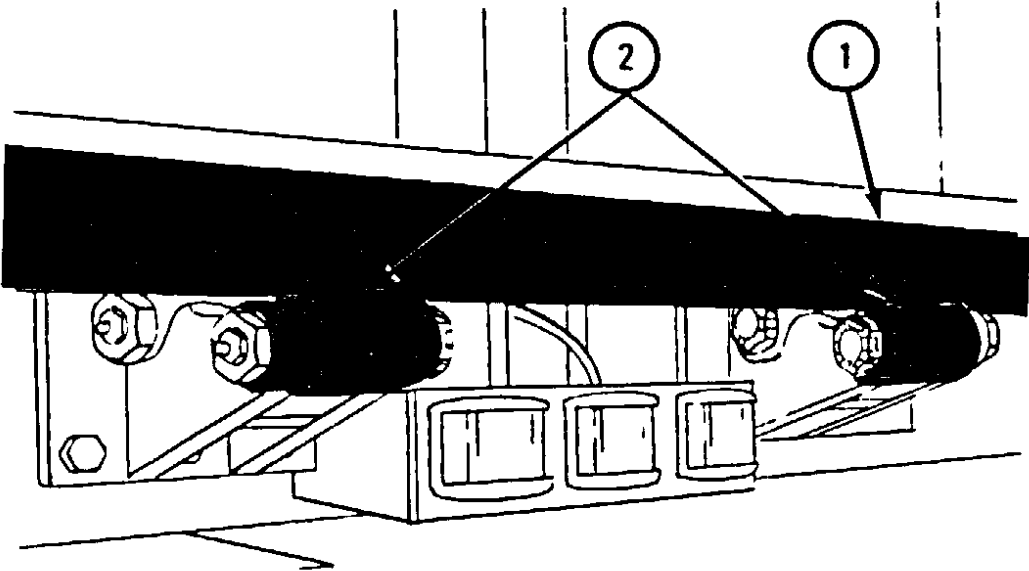
Item No.	Item To Be Inspected	Procedures Check for and Have Repaired, Replaced, Adjusted as Necessary	
6 (cont)		<p>3. Check that gin poles (1) are not bent and do not overlap more than 6-inches.</p>  <p style="text-align: center;">TA 045638</p> <p>4. Put gin poles (1) back in place. Refer to TM 9-2320-209-10.</p>	

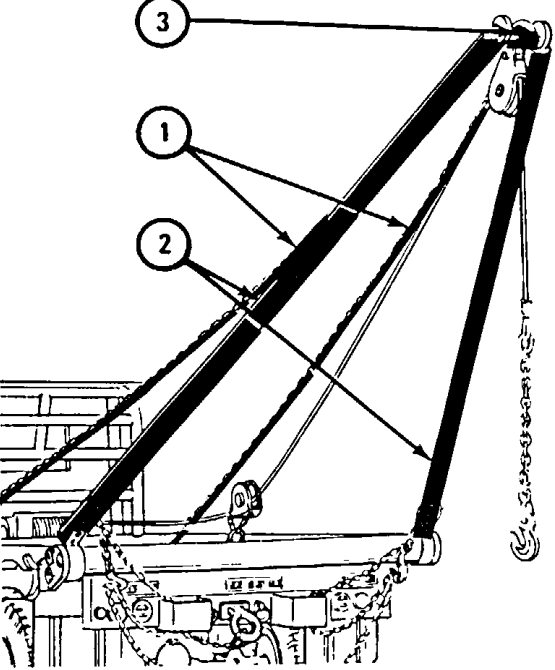
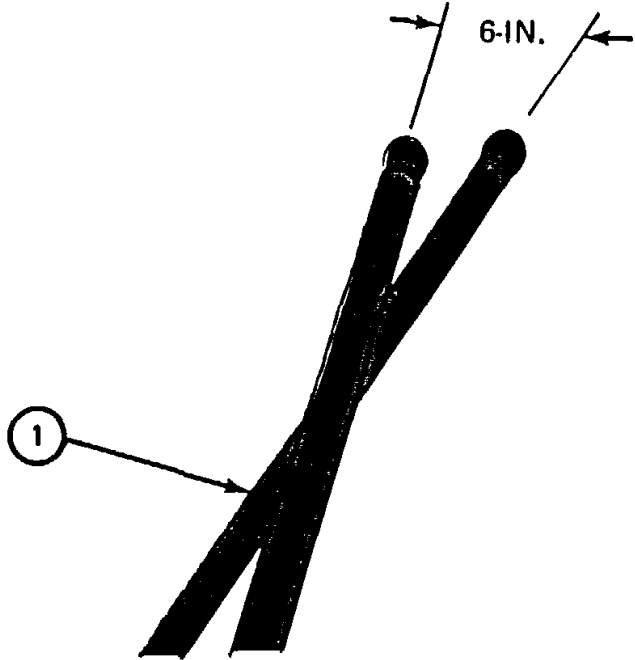
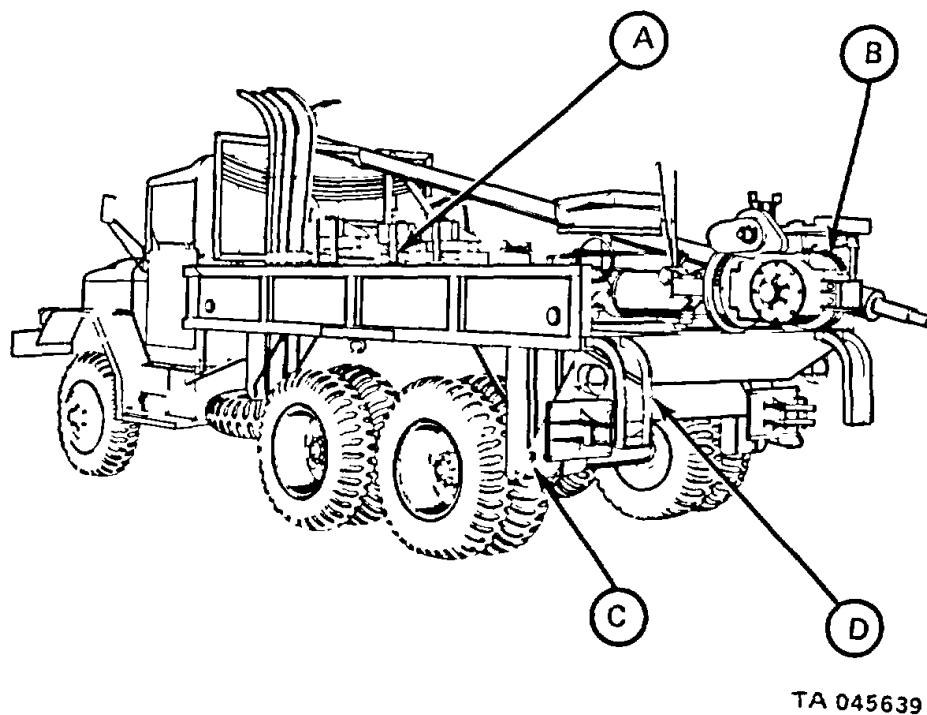

- A. Rear winch
- B. Earth boring machine

- C. Outriggers
- D. Outrigger hydraulic system

Figure 1-9. M764 Earth Boring Machine and Polesetter Truck, Preventive Maintenance Locators.

Table 1-9. Organizational Preventive Maintenance Checks and Services Semiannual Schedule for M764 Earth Boring Machine and Polesetter Truck

Item No.	Item To Be Inspected	Procedures Check for and Have Repaired, Replaced, Adjusted as Necessary	
1	Rear winch	<p>1. Check that rear winch control linkage (1) is not loose or damaged.</p>  <p style="text-align: right;">TA 080512</p> <p>2. Check rear winch control lever and POWER DIVIDER control lever for proper operation. Refer to TM 9-2320-209-10.</p> <p>3. Check that idler pulley (1) is not damaged and is tight against worm drive chain (2). There should be no slack in worm drive chain.</p>	

Table 1-9. Organizational Preventive Maintenance Checks and Services Semiannual Schedule for M764 Earth Boring Machine and Polesetter Truck - Cont

Item No.	Item To Be Inspected	Procedures Check for and Have Repaired, Replaced, Adjusted as Necessary	
1 (cont)		 <p style="text-align: center;">TA 080513</p> <p>4. Check tension on cable level winder drive chains as follows:</p> <p>(a) Take off level winder drive chain covers. Refer to Vol 3, chapter 19, para 19-17.</p>	

Table 1-9. Organizational Preventive Maintenance Checks and Services Semiannual Schedule for M764 Earth Boring Machine and Polesetter Truck - Cont

Item No.	Item To Be Inspected	Procedures Check for and Have Repaired, Replaced, Adjusted as Necessary	
1 (cont)		<p>(b) Reduction drive chains (1 and 2) should have no more than 1/2-inch slack.</p>  <p style="text-align: right;">TA 083211</p> <p>(c) Carriage cross chain (3) should have no slack.</p> <p>(d) Put level winder drive chain covers back in place. Refer to Vol 3, chapter 19, para 19-17.</p> <p>5. Unwind winch cable (4). Refer to TM 9-2320-209-10.</p>	

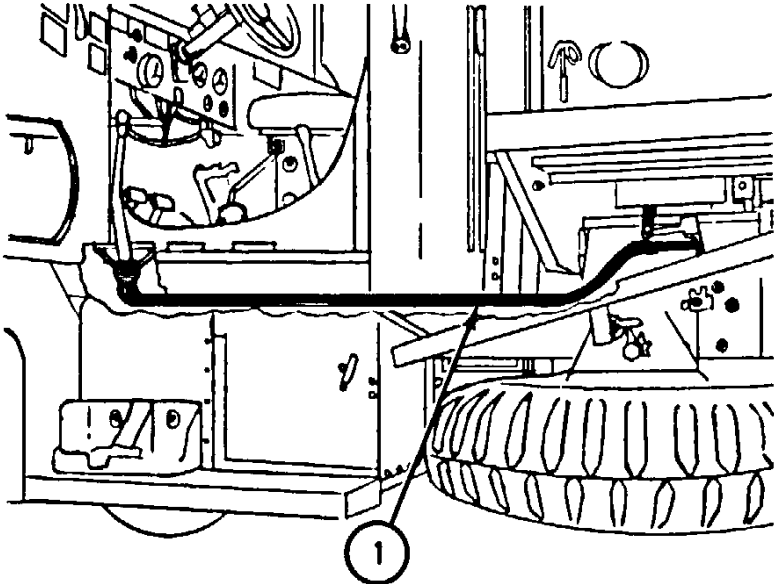
Table 1-9. Organizational Preventive Maintenance Checks and Services Semiannual Schedule for M764 Earth Boring Machine and Polesetter Truck - Cont

Item No.	Item To Be Inspected	Procedures Check for and Have Repaired, Replaced, Adjusted as Necessary	
1 (cont)		<ul style="list-style-type: none"> <li>6. Check that winch cable (4) is not kinked, and does not have broken wires or broken and loose clamps.</li> <li>7. Wind winch cable (4) back on drum (5). Refer to TM 9-2320-209-10.</li> <li>8. Check adjustment of winch automatic brake. Automatic brake should hold a 1,000 pound load without slipping. Refer to Vol 3, chapter 19, para 19-3 for test and adjustment procedures.</li> </ul>	
2	Earth boring machine	<ul style="list-style-type: none"> <li>1. Check tension on horizontal and vertical drive chains as follows:                             <ul style="list-style-type: none"> <li>(a) Take off drive chain covers. Refer to Vol 3, chapter 19, para 19-17.</li> <li>(b) Check that there is 1/8-inch slack in leveling worm drive chains (1 through 4).</li> </ul> </li> </ul>	

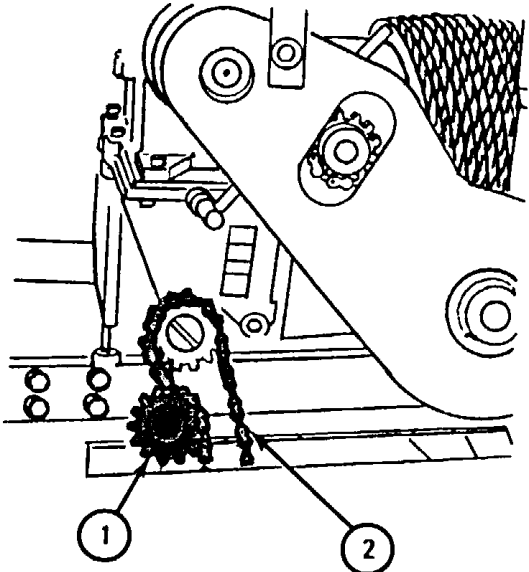
Table 1-9. Organizational Preventive Maintenance Checks and Services Semiannual Schedule for M764 Earth Boring Machine and Polesetter Truck - Cont

Item No.	Item To Be Inspected	Procedures Check for and Have Repaired, Replaced, Adjusted as Necessary	
2 (cont)		 <p style="text-align: right;">TA 083212</p> <p>(c) Put drive chain covers back on. Refer to Vol 3, chapter 19, para 19-17.</p> <ol style="list-style-type: none"> <li>2. Check that earth boring machine is not leaking oil.</li> <li>3. Tell direct support maintenance to check rack thrust plates and adjustments on leveling worms and clutch assembly.</li> </ol>	

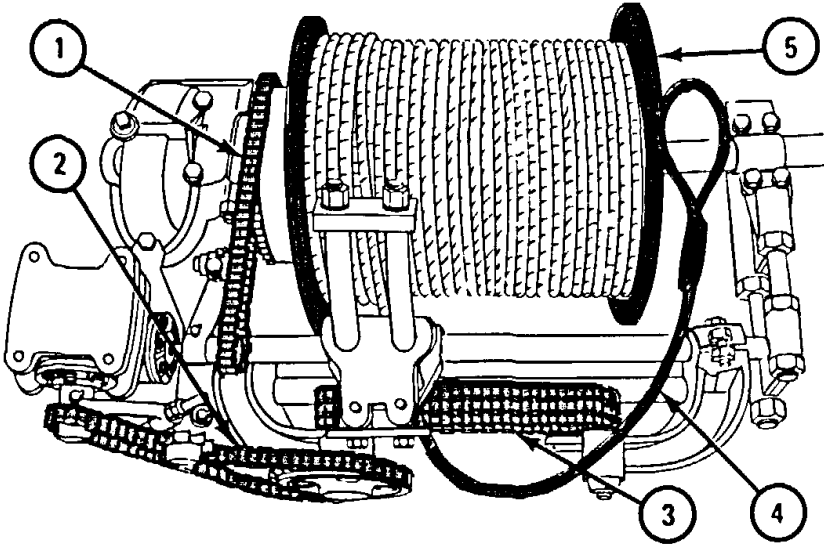

Table 1-9. Organizational Preventive Maintenance Checks and Services Semiannual Schedule for M764 Earth Boring Machine and Polesetter Truck - Cont

Item No.	Item To Be Inspected	Procedures Check for and Have Repaired, Replaced, Adjusted as Necessary	
3	Outriggers and hydraulic system	<p>1. Check that outrigger pump (1), control valve (2), and hoses (3) are not leaking. Hydraulic system parts are mounted under truck body at the rear.</p>  <p style="text-align: right;">TA 083213</p> <p style="text-align: center;"><b>NOTE</b></p> <p style="text-align: center;">Refer to TM 9-2320-209-10 for operating procedures when doing the following check.</p>	

Table 1-9. Organizational Preventive Maintenance Checks and Services Semiannual Schedule for M764 Earth Boring Machine and Polesetter Truck - Cont

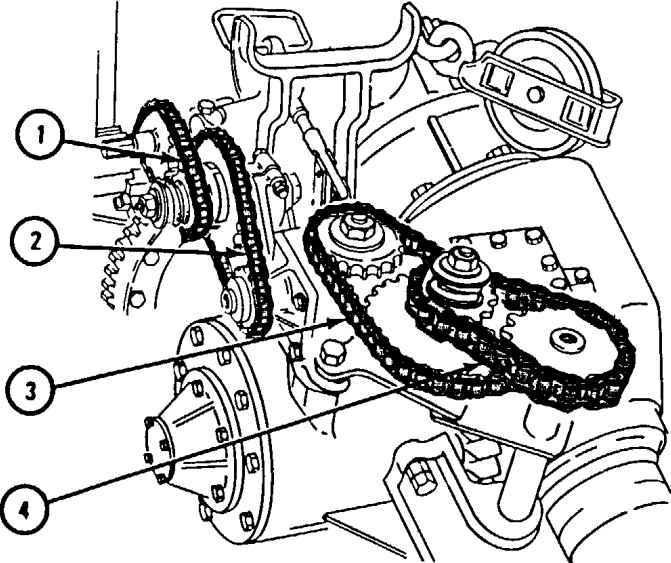
Item No.	Item To Be Inspected	Procedures Check for and Have Repaired, Replaced, Adjusted as Necessary	
3 (cont)		<p>2. Check outrigger legs for proper operation as follows:</p> <ul style="list-style-type: none"> <li>(a) Lower each leg so that leg lifts truck off ground.</li> <li>(b) Put control levers in NEUTRAL position. Legs should hold truck up without leaking back down.</li> <li>(c) Raise legs and put them back in stowed position.</li> </ul>	

## CHAPTER 2

### CHECKOUT, ALINEMENT, AND ADJUSTMENT

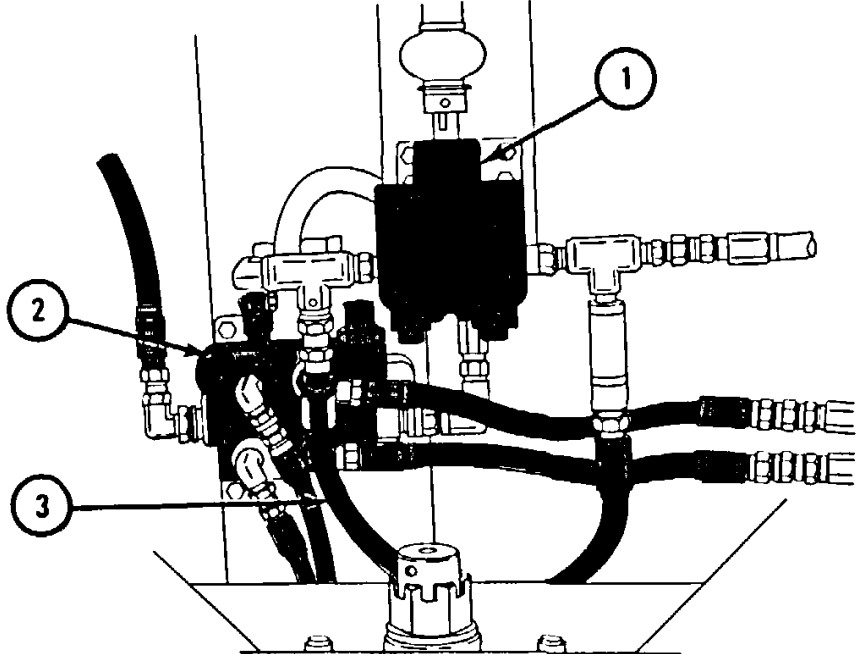
---

2-1. GENERAL. There are no scheduled checkout, alinement, or adjustment procedures to be done at organizational level of maintenance other than those in PMCS tables.

## CHAPTER 3

### LUBRICATION

---

3-1. GENERAL. Refer to LO 9-2320-209-12/1 for lubrication of the truck.

3-2. SPECIAL INSTRUCTIONS. There are no special lubrication instructions for trucks operating under unusual conditions other than those given in LO 9-2320-209-12/1.

## CHAPTER 4

### SCHEDULED MAINTENANCE OF MATERIAL USED IN CONJUNCTION WITH MAJOR ITEMS

---

4-1. GENERAL. These preventive maintenance checks and services (PMCS) cover the special purpose kits supplied as part of the truck. The special purpose kits include the bow and tarp kit, hot water personnel heater kit, arctic winterization kit, deep water fording kit, electric brake kit, and A-frame kit.

4-2. PMCS PROCEDURES. Refer to TM 9-2320-209-10 for preventive maintenance checks and services for the special purpose kits.

APPENDIX A

REFERENCES

A-1. PUBLICATION INDEXES AND GENERAL REFERENCE.

Indexes should be checked often for the latest changes or revisions of references given in this appendix and for new publications on materiel covered in this technical manual.

a. Military Publications Indexes.

Index of Army Motion Pictures and Related Audio-Visual Aids .....	DA Pam 108-1
Index of Administrative Publications .....	DA Pam 310-1
Index of Blank Forms .....	DA Pam 310-2
Index of Doctrinal Training and Organizational Publications .....	DA Pam 310-3

Military Publications:

Index of Technical Manuals, Technical Bulletins, Supply Bulletins, and Lubrications Orders.....	DA Pam 310-4
Index of Supply Catalogs and Supply Manuals (excluding types 7, 8, and 9) .....	DA Pam 310-6
Index of Modification Work Orders .....	DA Pam 310-7
Common Tools and Equipment .....	DA Supply Manuals SC-4910-95-CL-A01, A02, A50, -A31, -A32, A63, A64, A65, A67, A68, A72, A73, and A74.

b. General Reference.

Authorization Abbreviations and Brevity Codes .....	AR 310-50
Dictionary of United States Army Terms .....	AR 310-25

A-2. FORMS.

The following forms are for this materiel (refer to DA pamphlet 310-2 for index of blank forms and to TM 38-750 for explanation of their use).

Recommended Changes to Publications .....	DA Form 2028
Maintenance Request - Continuation Sheet .....	DA Form 2407-1
Equipment Log Assembly (Records) .....	DA Form 2408
Modification Work Order .....	DA Form 2408-5

A-3. OTHER PUBLICATIONS.

a. Vehicle.

Lubrication Order .....	LO 9-2320-209-12/1
Operator's Manual .....	TM 9-2320-209-10
Direct Support and General Support Maintenance Manual .....	TM 9-2320-209-34
Organizational Maintenance Repair Parts and Special Tool List .....	TM 9-2320-209-20P
Direct Support and General Support Maintenance Repair Parts and Special Tool List .....	TM 9-2320-209-34P

b. General.

Camouflage .....	FM 5-20
Camouflage of Vehicles .....	TB 43-0209
Chemical, Biological, and Radiological (CBR) Decontamination .....	TM 3-220
Chemical, Biological, Radiological, and Nuclear Defense.....	FM 21-40
Rigging.....	TM 5-725
Accident Reporting and Records .....	AR 385-40
Basic Cold Weather Manual .....	FM 31-70
Cooling Systems: Tactical Vehicles .....	TM 750-254
Manual for the Wheeled Vehicle Driver .....	FM 21-305
Driver Selection and Training (Wheeled Vehicles).....	TM 21-300
The Army Maintenance Management System .....	TM 38-750
Painting Instructions for Field Use.....	TM 43-0139
Materials Used for Cleaning, Preserving, Abrading and Cementing Ordnance Materiel and Related Materials Including Chemicals .....	TM 9-247

**APPENDIX B****MAINTENANCE ALLOCATION CHART**

---

## Section I. INTRODUCTION

**B-1. GENERAL.**

a. This section provides a general explanation of all maintenance and repair functions authorized at various maintenance levels.

b. The Maintenance Allocation Chart (MAC) in section II designates overall responsibility for the performance of maintenance functions on the identified end item or component. The implementation of the maintenance functions upon the end item or component will be consistent with the assigned maintenance functions.

c. Section III lists the special tools and test equipment required for each maintenance function as referenced from section II.

d. Section IV contains supplemental instructions on explanatory notes for a particular maintenance function.

**B-2. MAINTENANCE FUNCTIONS.**

a. Inspect. To determine the serviceability of an item by comparing its physical, mechanical and/or electrical characteristics with established standards through examination.

b. Test. To verify serviceability and detect incipient failure by measuring the mechanical or electrical characteristics of an item and comparing those characteristics with prescribed standards.

c. Service. Operations required periodically to keep an item in proper operating condition, i.e., to clean (decontaminate), to preserve, to drain, to paint, or to replenish fuel, lubricants, hydraulic fluids, or compressed air supplies.

d. Adjust. To maintain, within prescribed limits, by bringing into proper or exact position, or by setting the operating characteristics to specified parameters.

e. Align. To adjust specified variable elements of an item to bring about optimum or desired performance.

f. Calibrate. To determine and cause corrections to be made or to be adjusted on instruments or test measuring and diagnostic equipments used in precision measurement. Consists of comparisons of two instruments, one of which is a certified standard of known accuracy, to detect and adjust any discrepancy in the accuracy of the instrument being compared.

g. Install. The act of emplacing, seating, or fixing into position an item, part, or module (component or assembly) in a manner to allow the proper functioning of an equipment or system.

h. Replace. The act of substituting a serviceable like type part, subassembly, or module (component or assembly) for an unserviceable counterpart.

i. Repair. The application of maintenance services<sup>1</sup> or other maintenance actions<sup>2</sup> to restore serviceability to an item by correcting specific damage, fault, malfunction, or failure in a part, subassembly, module (component or assembly), end item, or system.

j. Overhaul. That maintenance effort (services/actions) necessary to restore an item to a completely serviceable/operational condition as prescribed by maintenance standards (i.e., DMWR) in appropriate technical publications. Overhaul is normally the highest degree of maintenance performed by the Army. Overhaul does not normally return an item to like new condition.

k. Rebuild. Consists of those services/actions necessary for the restoration of unserviceable equipment to a like new condition in accordance with original manufacturing standards. Rebuild is the highest degree of materiel maintenance applied to Army equipment. The rebuild operation includes the act of returning to zero those age measurements (hours/miles), etc.) considered in classifying Army equipments/ components.

**B-3. COLUMN ENTRIES USED IN THE MAC.**

a. Column 1, Group Number. Column 1 lists group numbers, the purpose of which is to identify components, assemblies, subassemblies, and modules with the next higher assembly.

b. Column 2, Component/Assembly. Column 2 contains the names of components, assemblies, subassemblies, and modules for which maintenance is authorized.

c. Column 3, Maintenance Functions. Column 3 lists the functions to be performed on the item listed in column 2. (For detailed explanation of these functions, see para B-2.)

d. Column 4, Maintenance Level. Column 4 specifies, by the listing of a "work time" figure in the appropriate subcolumn(s), the lowest level of maintenance authorized to perform the function listed in column 3. This figure represents the active time required to perform the maintenance function at the indicated level of maintenance. If the number or complexity of the tasks within the listed maintenance function vary at different maintenance levels, appropriate "work time" figures will be shown for each level. The number of manhours specified by the "work time" figure represents the average time required to restore an item (assembly, subassembly, component, module, end item, or system) to a serviceable condition under typical field operating conditions. This time includes preparation time, troubleshooting time, and quality assurance/quality control time in addition to the time required to perform the specific tasks identified for the maintenance functions authorized in the maintenance allocation chart. The symbol designations for the various maintenance levels are as follows:

- C .....Operator or crew
- O .....Organization maintenance
- F .....Direct support maintenance
- H .....General support maintenance
- D .....Depot maintenance

e. Column 5, Tools and Equipment. Column 5 specifies, by code, those common tools sets (not individual tools) and special tools, test, and support equipment required to perform the designated function.

f. Column 6, Remarks. This column contains a letter code in alphabetic order which is keyed to the remarks contained in section IV.

<sup>1</sup>Services-inspect, test, service, adjust, align, calibrate, or replace.

<sup>2</sup>Action-welding, grinding, riveting, straightening, facing, remachining, or resurfacing.

B-4. COLUMN ENTRIES USED IN TOOL AND TEST EQUIPMENT REQUIREMENTS.

- a. Column 1, Tool or Test Equipment Reference Code. The tool and test equipment reference code correlates with a maintenance function on the identified end item or component.
- b. Column 2, Maintenance Level. The lowest level of maintenance authorized to use the tool or test equipment.
- c. Column 3, Nomenclature. Name or identification of the tool or test equipment.
- d. Column 4, National/NATO Stock Number. The National or NATO stock number of the tool or test equipment.
- e. Column 5, Tool Number. The manufacturer's part number.

B-5. EXPLANATION OF COLUMNS IN SECTION IV.

- a. Reference Code. The code scheme recorded in column 6, section II.
- b. Remarks. This column lists information pertinent to the maintenance function being performed as indicated on the MAC in section II.



Section II. MAINTENANCE ALLOCATION CHART

(1) Group Number	(2) Component/Assembly	(3) Maintenance Function	(4) Maintenance Level					(5) Tools and Equipment	(6) Remarks
			C	O	F	H	D		
01	ENGINE								
0100	Engine Assembly (Multifuel)	Service Replace Repair	2.0		8.0 13.7			6,7,15,16,17, 32,33,34,35	
	Overhaul					38.5		1,2,3,4,5,6,7, 15,16,17,18, 19,32,33,34, 35,72,73	
	Pad, Engine Mounting	Replace		1.0					
0101	Crankcase, Block and Cylinder Head								
	Head, Cylinder Assembly	Replace Repair			2.0			9,10,11,12	
0102	Crankshaft	Replace					3.0	13,14	
0103	Flywheel Assembly	Replace Repair			3.5				
						2.0		66	
0104	Pistons, Connecting Rods								
	Connecting Rod	Replace Repair				2.0 1.0			
	Piston & Cylinder Sleeve Assembly	Replace					5.9	16,17,74,75, 76	
0105	Valves, Camshaft and Timing System								
	Valves, Intake and Exhaust	Adjust Replace			1.5 15.1			12,67	
	Guides, Valve Intake & Exhaust	Replace				3.0		70,71	
	Camshaft and Bearings	Replace				12.0		8	
	Gears, Timing	Replace				2.0			
0106	Engine Lubrication System							13,14,15	
	Oil Pump	Replace Repair Overhaul			3.0		1.0 3.0		

Section II. MAINTENANCE ALLOCATION CHART - Cont

(1) Group Number	(2) Component/Assembly	(3) Maintenance Function	(4) Maintenance Level					(5) Tools and Equipment	(6) Remarks
			C	O	F	H	D		
01	ENGINE - cont								
	Filter, Oil	Service Replace Repair		1.0 1.2	1.0			20,21	
	Pan, Oil	Replace Repair			3.0 2.0				
0108	Manifolds	Replace			2.0				
02	CLUTCH								
0200	Clutch Assembly								
	Plate, Pressure, Friction	Replace Repair			4.4 1.0			7	
	Disk, Clutch	Replace			4.4				
0202	Clutch Release Mechanism								
	Bearings, Clutch Release	Replace			4.2				
	Controls & Linkage Clutch	Service Adjust Replace	0.2	0.3 0.4					
03	FUEL SYSTEM								
0301	Carburetor, Fuel Injector								
	Nozzle and Holder, Fuel Injector	Replace Repair			2.0 4.0			30	
	Lines & Connections	Replace			0.5			68	
0302	Fuel Pump	Test Service Calibrate Replace Repair				1.5 1.0 2.0 1.5 2.5		31	
		Overhaul				20.1		22,23,24,25, 26,27,28,29, 31 As above	
0304	Air Cleaner	Service Replace Repair	0.3	0.8 0.5					

Section II. MAINTENANCE ALLOCATION CHART - Cont

(1) Group Number	(2) Component/Assembly	(3) Maintenance Function	(4) Maintenance Level					(5) Tools and Equipment	(6) Remarks
			C	O	F	H	D		
03	FUEL SYSTEM - cont								
0305	Turbocharger	Replace Repair  Overhaul			0.7  1.5 3.0			77,78,79,80, 81,82,83 As above	
0306	Tanks, Lines, Fittings, Headers								
	Tank, Fuel	Service Replace Repair	0.2	0.5	1.0				
	Lines, Connections and Fittings	Replace Repair		0.5 0.5					
0311	Fuel Filter	Service Replace Repair Test	0.1	0.3 1.0	0.5			69	
0311	Engine Starting Aids								
	Manifold Heater	Replace Repair		0.5 0.8					
0312	Accelerator, Throttle or Choke Controls								
	Controls and Linkage, Accelerator	Replace Repair		0.9 0.5					
	Throttle Controls and Engine Stop	Replace Repair		0.5 0.5					
04	EXHAUST PIPES								
0401	Muffler and Pipes	Replace		1.5					
05	COOLING SYSTEM								
0501	Radiator	Test Service Replace Repair	1.5	1.9	0.1  1.5				
	Cap, Radiator	Inspect Replace	0.1	0.1					

Section II. MAINTENANCE ALLOCATION CHART - Cont

(1) Group Number	(2) Component/Assembly	(3) Maintenance Function	(4) Maintenance Level					(5) Tools and Equipment	(6) Remarks
			C	O	F	H	D		
05	COOLING SYSTEM - cont								
0502	Shroud, Radiator Fan	Replace		0.3					
0503	Water Manifold, Headers, Thermostats and Housing Gasket								
	Hose, Lines and Fittings	Replace Repair		0.4 0.3					
	Manifold, Water (Multifuel)	Replace			0.8				
	Thermostat	Test Replace		0.5 0.5					
0504	Water Pump	Replace		0.8					
0505	Fan Assembly								
	Belt, Fan	Inspect Adjust Replace		0.1 0.2 1.0					
	Fan	Replace		0.2					
06	ELECTRICAL SYSTEM								
0601	Generator, Alternator	Test Replace Repair		0.2 0.5	2.0				
0602	Regulator	Test Replace		0.2 0.4					
0603	Starting Motor	Test Replace Repair		0.2 0.8	2.0				
0607	Instrument or Engine Control Panel								
	Instruments	Replace		0.2					
0608	Miscellaneous Items								
	Switches, Light	Replace		0.2					
	Flasher, Solid State	Replace		0.3					

Section II. MAINTENANCE ALLOCATION CHART - Cont

(1) Group Number	(2) Component/Assembly	(3) Maintenance Function	(4) Maintenance Level					(5) Tools and Equipment	(6) Remarks
			C	O	F	H	D		
06	ELECTRICAL SYSTEM - cont								
0609	Lights	Aline Replace Repair		0.3 0.5 0.7					
0610	Sending Units and Warning Switches	Test Replace		0.1 0.2					
0611	Horn	Adjust Replace Repair		0.1 0.2 0.5					
0612	Batteries, Storage	Test Service Replace	0.1	0.2 0.4					
0613	Hull or Chassis Wiring Harness	Test Inspect Replace Repair		0.2 0.5 2.0 2.2	4.0				
0615	Radio Interference Suppression Strap, Ground	Replace		0.2					
07	TRANSMISSION								
0700	Transmission Assembly	Service Replace Repair Overhaul		0.3	4.0 1.0	4.0 8.0	13 13,36 13,36		
0701	Transmission Shafts Transmission Top Cover Assembly	Replace Replace Repair				2.6 0.5 0.9			
08	TRANSFER AND FINAL DRIVE ASSEMBLIES								
0801	Power Transfer  Airlock Assembly	Service Replace Repair  Overhaul  Repair		0.3	1.0 1.0	6.0	13,39,41 13,37,38,39, 40,41 13,37,38,39, 40,41		
						11.2			

Section II. MAINTENANCE ALLOCATION CHART - Cont

(1) Group Number	(2) Component/Assembly	(3) Maintenance Function	(4) Maintenance Level					(5) Tools and Equipment	(6) Remarks
			C	O	F	H	D		
08	TRANSFER AND FINAL DRIVE ASSEMBLIES - cont								
0803	Gear Shift, Vacuum Booster and Controls								
	Controls and Linkage	Adjust Replace Repair		0.3 1.0 0.5					
09	PROPELLER SHAFTS								
0900	Shaft, Propeller, Assembly	Replace Repair		0.8 1.4					
	Joint, Universal	Service Replace Repair	0.1	0.7 1.5					
10	FRONT AXLE								
1000	Front Axle Assembly	Service Replace Repair Overhaul	0.5		4.5 5.2		57 57 57,61,62 57,61,62		
					3.2				
						20.5			
1002	Carrier, Differential	Service Replace Repair	0.3		7.5		45,47,56 40,42,44,45, 46,47,48,49, 55,56,64		
		Overhaul				19.5	40,42,43,44, 45,46,47,48, 49,55,56		
1004	Steering Mechanism	Service Replace Repair	0.1	1.5 0.5	2.2				
11	REAR AXLE								
1100	Rear Axle Assembly	Service Replace Repair Overhaul	0.3		6.0 4.0		57 57 57 57		
					2.0				
						38.9			
1102	Carrier, Differential	Service Replace Repair Overhaul	0.3		7.5		56 42,49,55,56 42,43,49,55,56		
						7.0 19.5			

Section II. MAINTENANCE ALLOCATION CHART - Cont

(1) Group Number	(2) Component/Assembly	(3) Maintenance Function	(4) Maintenance Level					(5) Tools and Equipment	(6) Remarks
			C	O	F	H	D		
12	BRAKES								
1201	Hand Brakes								
	Drum, Hand Brake	Replace Repair		1.2	2.0				
	Shoe, Hand Brake	Replace Repair		0.5	0.8				
	Linkage, Parking	Service Adjust Replace	0.1	0.1 0.5					
1202	Service Brakes								
	Shoe, Brake Service	Adjust Replace Repair		0.1 1.4	1.7				
1204	Hydraulic Brake System								
	Cylinder, Master	Service Replace		0.1 2.0					
	Cylinder, Air Hydraulic	Replace Repair Overhaul		0.9	1.5	3.0	53 50,51,52		
1206	Mechanical Brake System								
	Brake Pedal	Adjust Replace		0.2 0.2					
1208	Air Brake System								
	Lines and Fittings	Replace		0.1					
	Reservoir, Air	Service Replace	0.1	1.6					
1209	Air Compressor Assembly								
	Belt, Drive	Service Replace		0.1 1.6					
		Inspect Adjust Replace		0.1 0.2 1.1					

Section II. MAINTENANCE ALLOCATION CHART - Cont

(1) Group Number	(2) Component/Assembly	(3) Maintenance Function	(4) Maintenance Level					(5) Tools and Equipment	(6) Remarks
			C	O	F	H	D		
12	BRAKES - cont								
	Governor, Air	Adjust Replace		0.4 0.3					
1211	Trailer Brake Connections and Controls								
	Coupling, Trailer Brake	Replace Repair		0.4 0.2					
13	WHEELS								
1311	Wheel Assembly								
	Hub Assembly	Service Replace Repair		0.1 1.3 1.8			57 54,63,64		
	Drum, Service Brake	Replace Repair		1.2	0.5		57 57		
1313	Tires	Service Replace Repair	0.1	1.2		0.8			
14	STEERING								
1401	Mechanical Steering Gear Assembly								
	Drag Link Assembly	Adjust Replace Repair		0.1 0.3 0.5					
	Gear, Steering	Adjust Service Replace Repair	0.1	0.3 3.2		4.3	58,59,60,65		
	Tie Rod Assembly	Replace Repair		1.2 1.5					
15	FRAME TOWING ATTACHMENTS AND DRAWBARS								
1501	Frame Assembly	Repair		1.0			20.0		
1503	Pintles and Towing Attachments	Replace Repair		0.2 0.7					



Section II. MAINTENANCE ALLOCATION CHART - Cont

(1) Group Number	(2) Component/Assembly	(3) Maintenance Function	(4) Maintenance Level					(5) Tools and Equipment	(6) Remarks
			C	O	F	H	D		
15	FRAME TOWING ATTACHMENTS AND DRAWBARS - cont								
1504	Spare Wheel Carrier and Tire Lock	Replace		0.8					
		Repair		1.2					
16	SPRINGS AND SHOCK ABSORBERS								
1601	Springs								
	Springs, Front	Replace		1.6					
		Repair		2.4					
	Springs, Rear	Replace		1.0					
		Repair		1.8					
	Springs, Rear Seat	Repair			1.0				
1604	Shock Absorber Equipment	Replace		0.3					
1605	Torque, Radius and Stabilizer Rods	Replace		0.4					
18	BODY, CAB, HOOD, AND HULL								
1801	Body, Cab, Hood and Hull Assemblies								
	Cab	Repair			12.0				
	Door	Replace			0.4				
		Repair		0.2	0.5				
	Hood	Replace		0.2					
		Repair		0.7					
1802	Fenders, Running Boards with Mounting and Attaching Parts, Outriggers, Windshield, Glass, etc.								
	Fender	Replace			0.8				
	Windshield	Service	0.1						
		Replace		0.4					
		Repair		0.2	0.8				
1806	Upholstery, Seats and Carpets	Replace		0.6					
		Repair		0.2	0.3				

Section II. MAINTENANCE ALLOCATION CHART - Cont

(1) Group Number	(2) Component/Assembly	(3) Maintenance Function	(4) Maintenance Level					(5) Tools and Equipment	(6) Remarks
			C	O	F	H	D		
18	BODY, CAB, HOOD AND HULL - cont								
1808	Stowage Racks, Boxes, Straps Carrying Cases, Cable Reels, Hose Reels, etc.	Replace Repair		0.2 0.5					
1810	Cargo Body	Replace Repair			1.0	3.0 3.0			
	Rack and Seat Assembly	Replace Repair		0.4 0.6					
	Tailgate	Service Replace Repair	0.1	0.6	0.3				
20	HOIST, WINCH, CAPSTAN, WINDLASS, POWER CONTROL UNIT AND POWER TAKEOFF								
2001	Hoist, Capstan, Windlass, Crane or Winch Assembly								
	Winch	Service Adjust Replace Repair Overhaul	0.3	0.3 1.6 1.0	1.6	3.0 5.6			
	Band, Automatic Brake	Adjust Replace Repair		0.2	0.3 1.0				
	Cable, Winch	Service Inspect Replace Repair	0.4 0.2	0.8 1.0					
	Shaft Assembly, Drive	Service Replace	0.1	0.8					
	Shear Pin	Replace		0.2					
2004	Power Takeoff Assembly	Replace Repair			1.0	2.4			
	Controls and Linkage	Adjust Replace Repair		0.3 0.3					
					0.4				

Section II. MAINTENANCE ALLOCATION CHART - Cont

(1) Group Number	(2) Component/Assembly	(3) Maintenance Function	(4) Maintenance Level					(5) Tools and Equipment	(6) Remarks
			C	O	F	H	D		
21	BUMPERS AND GUARDS								
2101	Bumpers, Brackets, Guards and Protective Devices	Replace Repair			0.6 0.8				
	Guard, Radiator	Replace Repair			0.6 0.8				
22	BODY, CHASSIS AND ACCESSORY ITEMS								
2201	Canvas, Rubber or Plastic Items								
	Bows	Replace Repair	0.1	0.2					
	Cover, Body	Replace Repair	0.1		0.5				
	Curtain, Body	Replace Repair	0.1		0.3				
2202	Accessory Items								
	Motor, Windshield Wiper	Replace		0.2					
	Mirror Assembly	Service Replace Repair	0.1		0.2 0.2				
	Windshield Washer Kit	Install Repair			2.0				
				1.0					
2210	Data Plates and Instruction Holders	Replace		0.1					
33	SPECIAL PURPOSE KITS								
3301	Reusable Shipping Container	Repair				1.0			
3303	Winterization Kits	Install Inspect Service Repair	0.2 0.2			25.0			
				2.0	8.0				
3305	Deep Water Fording Kits	Install Inspect Repair	0.2		12.0				
				0.5	6.0				

Section II. MAINTENANCE ALLOCATION CHART - Cont

(1) Group Number	(2) Component/Assembly	(3) Maintenance Function	(4) Maintenance Level					(5) Tools and Equipment	(6) Remarks
			C	O	F	H	D		
33	SPECIAL PURPOSE KITS - cont								
3307	Special Purpose Kits								
	A-Frame Kit	Install Inspect Repair	0.2		2.0				
	Decontamination Bracket Kit	Install Replace		0.5	1.0				
				0.3					
47	GAGES (NON-ELECTRICAL)								
4701	Instruments (Speed and Distance)								
	Speedometer	Replace		0.4					
	Shaft Assembly, Flexible	Replace		0.4					
	Tachometer	Replace		0.4					
	Shaft Assembly, Flexible	Replace		0.4					
	Joint, Angle Drive	Replace Repair		0.6 0.6					
	SUPPLEMENT NUMBER 1								
	Truck, Dump, 2-1/2 Ton, 6x6, M342A2								
	<b>NOTE: This supplement pertains to maintenance operations peculiar to the Truck, Dump, M342A2, and must be used in conjunction with basic allocation chart.</b>								
18	BODY								
	Body, Dump	Repair			3.0				
	Tailgate	Replace Repair			0.6 1.0				

Section II. MAINTENANCE ALLOCATION CHART - Cont

(1) Group Number	(2) Component/Assembly	(3) Maintenance Function	(4) Maintenance Level					(5) Tools and Equipment	(6) Remarks
			C	O	F	H	D		
20	HOIST, WINCH, CAPSTAN, WINDLASS, POWER CONTROL UNIT AND POWER TAKEOFF								
2001	Hoist, Capstan, Windlass, Crane or Winch Assembly								
	Cylinder Assembly, Hoist	Replace Repair			2.0 3.0				
	Pump Assembly	Replace Repair			2.0 4.5				
	Shaft Assembly, Drive	Service Replace Repair	0.1	0.8 1.4					
	Valve, Control	Replace Repair			2.7	3.2			
2004	Power Takeoff Assembly	Replace Repair			1.0	2.4			
	Controls and Linkage	Adjust Replace Repair		0.3 0.3	0.4				
	SUPPLEMENT NUMBER 2								
	Truck Tractor, 2-1/2 Ton, 6x6, M275A1 and M275A2								
	<b>NOTE: This supplement pertains to maintenance operations peculiar to the Truck, Tractor, M275A1/M275A2 and must be used in connection with basic allocation chart.</b>								
12	BRAKES								
1211	Trailer Brake Connections and Controls								
	Valve, Hand Control	Replace Repair		0.4 0.2	1.0				
	Hose, Trailer Brake	Replace Repair		0.1 0.3					

Section II. MAINTENANCE ALLOCATION CHART - Cont

(1) Group Number	(2) Component/Assembly	(3) Maintenance Function	(4) Maintenance Level					(5) Tools and Equipment	(6) Remarks
			C	O	F	H	D		
15	FRAME TOWING ATTACHMENTS AND DRAWBARS								
1506	Fifth Wheel	Service Replace Repair	0.1	1.0 0.2	2.0				
	SUPPLEMENT NUMBER 3								
	Truck, Tank, Fuel, 2-1/2 Ton, 6x6, 1200 Gallons, M49A1C, M49A2C								
	<b>NOTE: This supplement pertains to maintenance operations peculiar to the Truck, Tank, Fuel M49A1C/M49A2C, and must be used in conjunction with basic allocation chart.</b>								
18	BODY, CAB, HOOD AND HULL								
1811	Tank Bodies								
	Body, Tank	Repair				6.0			
	Cover, Manhole	Replace Repair		0.2 0.7					
	Pump, Delivery	Service Replace Repair	0.2	0.5		1.5			
	Reel Assembly, Static Ground	Replace Repair		0.2 0.2					
	Segregator (M49A1C)	Service Replace Repair		0.2 0.9 1.1					
	Filter Separator (M49A2C)	Service Replace Repair		0.2 0.9 1.1					
	Shaft Assembly, Drive	Service Replace Repair	0.1	0.8 1.4					
	Valve, Discharge	Replace Repair		0.5 0.3	1.0				

Section II. MAINTENANCE ALLOCATION CHART - Cont

(1) Group Number	(2) Component/Assembly	(3) Maintenance Function	(4) Maintenance Level					(5) Tools and Equipment	(6) Remarks
			C	O	F	H	D		
20	HOIST, WINCH, CAPSTAN, WINDLASS, POWER CONTROL UNIT AND POWER TAKEOFF								
2004	Power Takeoff Assembly	Replace Repair			1.0		2.4		
	Controls and Linkage	Adjust Replace Repair		0.3 0.3			0.4		
22	BODY, CHASSIS AND ACCESSORY ITEMS								
2202	Accessory Items								
	Hose Assembly, Dispenser	Replace Repair		0.2			0.3		
	Nozzle Assembly	Replace Repair		0.1			0.5		
47	GAGES (NON-ELECTRICAL)								
4705	Flow Meters and Regulators								
	Meter, Liquid	Replace			0.5				
	SUPPLEMENT NUMBER 4								
	Truck, Tank, Water, 2-1/2 Ton, 6x6, 1000 Gallons, M50A1, M50A2, M50A3								
	<b>NOTE: This supplement pertains to maintenance operations peculiar to the Truck, Tank, Water, M50A1, M50A2, M50A3, and must be used in conjunction with basic allocation chart.</b>								
04	EXHAUST SYSTEM								
0401	Muffler and Pipes								
	Pipe, Flexible, Exhaust, Heater	Replace		0.2					
	Valve, Bypass, Water Tank Body, Heater	Replace Repair		0.5 0.7					

Section II. MAINTENANCE ALLOCATION CHART - Cont

(1) Group Number	(2) Component/Assembly	(3) Maintenance Function	(4) Maintenance Level					(5) Tools and Equipment	(6) Remarks
			C	O	F	H	D		
18	BODY, CAB, HOOD AND HULL								
1811	Tank Bodies								
	Body, Tank	Repair				6.0			
	Cover, Manhole	Replace Repair		0.2 0.3					
	Pump, Delivery	Service Replace Repair	0.2	0.5		1.5			
	Shaft Assembly, Drive	Service Replace Repair	0.1	0.8 1.4					
	Valve, Discharge	Replace Repair		0.5	1.0				
22	BODY, CHASSIS AND ACCESSORY ITEMS								
2202	Accessory Items								
	Hose Assembly	Replace		0.1					
	Nozzle Assembly	Replace Repair		0.1	0.5				
	SUPPLEMENT NUMBER 5								
	Truck, Shop Van, 2-1/2 Ton, 6x6, M109A2, M109A3, M185A2, M185A3								
	<b>NOTE: This supplement pertains to maintenance operations peculiar to the Truck Shop Van M109A2, M109A3, M185A2, M185A3, and must be used in conjunction with basic allocation chart for Truck, Cargo, 2-1/2 Ton, 6x6, SNL G- 742.</b>								
18	BODY, CAB, HOOD AND HULL								
1812	Special Purpose Bodies	Repair			3.0				
	Blower, Exhaust and Ventilator	Replace		0.5					



Section II. MAINTENANCE ALLOCATION CHART - Cont

(1) Group Number	(2) Component/Assembly	(3) Maintenance Function	(4) Maintenance Level					(5) Tools and Equipment	(6) Remarks
			C	O	F	H	D		
18	BODY, CAB, HOOD AND HULL - cont								
	Converter	Replace			0.5				
	Door	Replace Repair		0.4 1.0					
	Harness, Main Wiring	Replace Repair		1.0	5.0				
	Lights	Replace Repair		1.0 0.2					
	Multi-breaker Assembly	Replace Repair		0.1	1.0				
	Sash Assembly, Window	Replace Repair			0.5 0.5				
	Switches	Replace		0.4					
	SUPPLEMENT NUMBER 6								
	Truck, Earth Boring Machine and Pole Setter, 2-1/2 Ton, 6x6, M764								
	<b>NOTE: This supplement pertains to maintenance operations peculiar to the Truck, Earth Boring Machine and Pole Setter M764, and must be used in conjunction with the basic allocation chart.</b>								
18	BODY, CAB, HOOD AND HULL								
1812	Special Purpose Bodies								
	Auger	Replace Repair	0.1 0.2						
	Body	Repair			4.0				
	Boring Case and Gears	Service Replace Repair	0.1			2.0 6.0		66	
	Clutch and Brake Assembly (Input)	Service Replace Repair	0.1			4.0 8.0			

Section II. MAINTENANCE ALLOCATION CHART - Cont

(1) Group Number	(2) Component/Assembly	(3) Maintenance Function	(4) Maintenance Level					(5) Tools and Equipment	(6) Remarks
			C	O	F	H	D		
18	BODY, CAB, HOOD AND HULL - cont								
	Clutch and Brake (Feed)	Repair				4.0		68	
	Derrick Assembly	Service Replace Repair	0.1		1.0 3.0				
	Leveling Worm Assembly, Horizontal	Service Replace Repair	0.1			1.4 3.0		67	
	Leveling Worm Assembly, Vertical	Service Replace Repair	0.1			1.5 3.0		67	
	Intermediate Case and Gears	Service Replace Repair	0.1			2.5 3.0			
	Lever Assembly, Operation	Service Replace Repair	0.1		2.0 1.5				
	Gears and Housing, Main Drive Idler	Service Replace Repair	0.1			2.0 3.0			
	Power Leveler Assembly	Service Replace Repair	0.1			1.0 3.0	0.5		
	Shaft, Propeller Drive	Service Replace Repair	0.1		0.4 0.8				
	Sheave Assembly	Service Replace Repair	0.1	0.2	0.5				
	OUTRIGGERS AND HYDRAULIC SYSTEMS								
	Cylinder Outrigger Legs	Replace Repair			1.0	2.0			
Hose and Fittings	Replace		0.5						

Section II. MAINTENANCE ALLOCATION CHART - Cont

(1) Group Number	(2) Component/Assembly	(3) Maintenance Function	(4) Maintenance Level					(5) Tools and Equipment	(6) Remarks
			C	O	F	H	D		
18	BODY, CAB, HOOD AND HULL - cont								
	Leg Assembly, Outrigger	Replace Repair			0.4 1.0				
	Shaft Assembly, Pump	Service Replace Repair	0.1						
	Pump Assembly, Hydraulic	Replace			0.5				
	Valve, Outrigger Control	Replace			0.6				
20	HOIST, WINCH, CAPSTAN, WINDLASS, POWER CONTROL UNIT AND POWER TAKEOFF								
2001	Hoist, Winch, Capstan, Windlass, Crane or Winch Assembly								
	Winch Assembly (Rear)	Service Adjust Replace Repair	0.1	1.0	1.6	3.0			
2004	Power Takeoff Assembly								
	Power Divider	Replace Repair			1.2	2.5			
	Controls and Linkage	Adjust Replace Repair		0.3 0.3	0.4				
	Shaft, Propeller Drive	Service Replace Repair	0.1	0.8 1.4					
	SUPPLEMENT NUMBER 7  Truck, Pipeline Construction, 2- 1/2 Ton, 6x6, M756A2  <b>NOTE: This supplement pertains to maintenance operations peculiar to the truck. Pipeline Construction M756A2, and must be used in conjunction with basic allocation chart for Truck, Cargo, 2-1/2 ton, 6x6.</b>								

Section II. MAINTENANCE ALLOCATION CHART - Cont

(1) Group Number	(2) Component/Assembly	(3) Maintenance Function	(4) Maintenance Level					(5) Tools and Equipment	(6) Remarks
			C	O	F	H	D		
18	BODY, CAB, HOOD AND HULL								
1812	Special Purpose Bodies								
	Body, Pipeline Construction	Repair			4.0				
20	HOIST, WINCH, CAPSTAN, WINDLASS, POWER CONTROL UNIT AND POWER TAKEOFF								
2001	Hoist, Capstan, Windlass, Crane or Winch Assembly								
	Winch Assembly (Rear)	Service Adjust Replace Repair	0.3	1.0	1.6				
				2.0		3.0			
2004	Power Takeoff	Replace Repair			1.0				
	Sprocket, Transfer PTO	Replace		0.2		2.4			

## Section III. TOOL AND TEST EQUIPMENT REQUIREMENTS

(1) Reference Code	(2) Maintenance Level	(3) Nomenclature	(4) National/NATO Stock Number	(5) Tool Number
1	HD	Stand, Maintenance, Automotive Engine: Engine Overhaul (Used with Cradle 4910-00-795-0198)	4910-00-795-0189	7950189
2	HD	Cradle Assembly: Engine Universal (Used with Stand 4910-00-795-0189)	4910-00-795-0198	7950198
3	HD	Bracket Angle: Engine Mounting, Right and left Front (Used with Cradle 4910-00-795-0198) (2 Required per Operation)	5340-00-043-5264	10935299
4	HD	Bracket, Double Angle: Engine Mounting Right Rear (Used with Cradle 4910-00-795-0198)	4910-00-873-1926	10899188
5	HD	Bracket Double Angle: Engine Mounting Left Rear (Used with Cradle 4910-00-795-0198)	4910-00-873-1925	10912239
6	OFHD	Wrench, Pulley Adjusting: Air Compressor Pulley	5120-00-070-7809	10935288
7	FHD	Socket, Wrench, Face Spanner: Clutch Release Lever Adjusting Nut	5120-00-034-8443	8390134
8	HD	Remover and Replacer Kit, Bushing: Camshaft Bearings	5120-00-870-6919	10899154
9	HD	Replacing Tool: Intake Valve Seat Insert	5120-00-134-7473	11642007
10	HD	Remover, Valve Guide: Removing or Installing Valve Guides (Used w/Replacer 5120-00-870-6921)	5120-00-871-3513	10999157
11	HD	Replacer, Valve Guide: Install Valve Guides (Used with Remover 5120-00-871-3515)	5120-00-870-6921	10899158
12	FHD	Compressor Assembly, Valve: Compressing Valve Springs or Rotors while Engine is in Vehicle	5120-00-933-6057	10951361
13	FHD	Puller Kit Mechanical: (Crankshaft Pulley: Use w/5120-00-870-6914 Adapter: Crankshaft Gear, Camshaft Gear, Com- pressor or Water Pump Pulley)	5120-00-338-6721	8708724

## Section III. TOOL AND TEST EQUIPMENT REQUIREMENTS - Cont

(1) Reference Code	(2) Maintenance Level	(3) Nomenclature	(4) National/NATO Stock Number	(5) Tool Number
14	FHD	Plug, Mechanical Puller: Used with Puller 5120-00-338-6721 (Adapter)	5120-00-870-6914	10899178
15	FHD	Replacer, Gear: Crankshaft Gear	5120-00-870-6920	10899179
16	FHD	Expander, Piston Ring	5120-00-068-7234	10935314
17	FHD	Compressor, Piston Ring: Compressing or Gaging Piston Rings	5120-00-068-7238	10935313
18	HD	Ram Kit, Hydraulic: Cylinder Sleeve Removal (Used with 10935312, Remover and Replacer)	4910-00-873-1927	10912249
19	HD	Tool Kit, Cylinder: Remove or Install Cylinder Sleeve (Used with Ram Kit 4910-00-873-1927)	5180-00-071-0736	10935312
20	FHD	Extractor, Coil Thread Insert: Helical Threaded Insert, Oil Filter (7/16 to 1" Thd. Size)	5120-00-251-1527	7751056
21	FHD	Insert, Screw Thread Insert: Helical Threaded Insert, Oil Filter (1-14 Thd)	5120-00-204-0881	10912379
22	HD	Wrench, Spanner: (Bearing Lock Nut)	5120-00-870-6926	10899169
23	HD	Fixture: (Holding Camshaft)	4910-00-870-2131	10899172
24	HD	Fixture: (Holding Pump)	4910-00-870-2128	10899198
25	HD	Compressor, Spring: (Outer Plunger Tappet Spring)	5120-00-870-6925	10899170
26	HD	Puller, Mechanical Bearing Plate: Spider Assembly: Used w/5120-00-793-5055 Remover and Replacer	5120-00-793-5048	10882818
27	HD	Remover and Replacer Plunger Locks: Removing Camshaft from Housing: Replacing Bearing on Camshaft: Replacing Spider Weight Assembly on Camshaft: Removing Weight Assembly from Camshaft: Used w/5120-00-793-5048, Puller	5120-00-793-5055	10882856

## Section III. TOOL AND TEST EQUIPMENT REQUIREMENTS - Cont

(1) Reference Code	(2) Maintenance Level	(3) Nomenclature	(4) National/NATO Stock Number	(5) Tool Number
28	HD	Gage: (Spring Gap)	4910-00-793-5040	10882854
29	HD	Wrench, Spanner: (Spider Clutch Spring Tension Adjusting Nut)	5120-00-793-5046	10882889
30	F	Tester, Nozzle	4910-00-255-8641	11020499
31	H	Tester, Fuel Injector Pump	4910-00-817-7431	11020200
32	FHD	Wrench, Box: Cylinder Head Nuts (Long)	5120-00-937-7834	10951484
33	FHD	Wrench, Box: Cylinder Head Nuts (Short)	5120-00-030-6346	10951485
34	FHD	Adapter, Cylinder Compression Tester: Checking Cylinder Compression (Used w/Gage Assembly 4910-00-870-6283)	4910-00-870-2127	10889183
35	FHD	Gage Assembly. Checking Cylinder Compression (Used with Adapter 4910-00-870-2127)	4910-00-870-6283	10899180
36	HD	Adapter, Mechanical Puller- (Reverse Idler Gear: used w/5120-00-313-9496 Puller)	5120-00-708-3254	70883254
37	HD	Bracket: (Adapting Right Side of Transfer Case to Stand 4910-00-449-4196)	4910-00-610-0920	7010363
38	HD	Bracket: (Adapting Left Side of Transfer Case to Stand 4910-00-449-4196)	5340-00-610-0919	7010362
39	FHD	Fixture, Transfer Case: (Removing and/or Replacing Transfer Case Used with Lift 4910-00-422-8565)	4910-00-694-4777	8708279
40	HD	Remover and Replacer: (Transfer Idler Shaft Front Bearing Cup; Used w/5120-00-708-3241 Handle)	5120-00-708-3247	7083247
41	FHD	Handle, Remover and Replacer: (Used w/Removers and Replacers)	5120-00-708-3241	7083241
42	HD	Puller Screw Type. (Differential Spider Pinion Bushing)	5120-00-836-6689	8366689
43	D	Burnisher: Differential Spider Pinion Bushing)	5120-00-708-3236	7083236

## Section III. TOOL AND TEST EQUIPMENT REQUIREMENTS - Cont

(1) Reference Code	(2) Maintenance Level	(3) Nomenclature	(4) National/NATO Stock Number	(5) Tool Number
44	HD	Replacer, Bearing Cup: (Differential Helical Drive Pinion Bearing Cup; Used w/5120-00-708-3241 Handle)	5120-00-708-3252	7083252
45	FHD	Replacer, Oil Seal: (Differential Carrier Through Shaft Oil Seals; Used w/5120-00-708-3241 Handle)	5120-00-708-3256	7083256
46	HD	Replacer, Gear: (Differential: Carrier Bevel Gear)	5120-00-708-3257	7083257
47	FHD	Remover, Oil Seal: (Differential Carrier Through Shaft Rear Oil Seal; Used w/5210-00-708-3241 Handle)	5120-00-708-3250	7083250
48	HD	Remover, Bearing: (Differential, Helical Drive Pinion Bearing Used w/5120-00-708-3241 Handle)	5120-00-708-3251	7083251
49	HD	Remover and Replacer, Bearing Sleeve. (Differential Carrier Bevel Gear Bearing Sleeve; Used w/5120-00-708-3216 Screw)	5120-00-708-3246	7083246
50	OFHD	Gage Pressure, Dial, Indicating (Air Brake Checking Air Pressure)	6685-00-387-9654	7541305
51	FHD	Wrench, Socket (Wheel Stud Nut)	5120-00-293-2452	7083293 41-W-3843-1
52	HD	Wrench, Hook Spanner: (Differential Side Bearing, Adjusting Ring)	5120-00-708-3260	7083260 41-N-3250-4
53	FHD	Remover, Oil Seal (Differential Carrier Through Shaft Front Oil Seal; Used w/5120-00-708-3241 Handle)	5120-00-708-3249	7083249
54	OFHD	Replacer, Oil Seal: (Front or Rear Wheel Hub Inner Oil Seal)	5120-00-947-2232	10937827
55	HD	Burnisher, Sleeve Bearing Hand: (Steering Gear Housing/Pitman Arm Shaft Bearings)	5120-00-708-3238	7083238
56	OFHD	Adapter Puller: (Steering Wheel, Used with Puller 5120-00-422-8570)	5120-00-473-6919	7078990



## Section III. TOOL AND TEST EQUIPMENT REQUIREMENTS - Cont

(1) Reference Code	(2) Maintenance Level	(3) Nomenclature	(4) National/NATO Stock Number	(5) Tool Number
57	FH	Burnisher: (Steering Knuckle Sleeve Bushing)	5120-00-708-3237	7083237
58	FHD	Replacer, Oil Seal: (Front Axle Universal Joint Oil Seal; Used w/5120-00-708-3241 Handle)	5120-00-708-3258	7083258
59	FHD	Puller, Oil Seal & Retainer: (Front Axle Universal Joint Inner Oil Seal and Retainer: Used w/5120-00-423-1596 Puller)	5120-00-310-4669	782863
60	OFHD	Remover and Replacer: (Wheel Bearing Cup or Rear Seat Bearing Cup, Used w/5120-00-708-3216 Screw)	5120-00-473-7372	7082863
61	OFHD	Screw, Remover and Replacer: Used w/Remover and Replacer 5120-00-473-7372 and 5120-00-708-3246	5120-00-708-3216	7083216 41-S-1047 330
62	HD	Remover and Replacer: (Steering Gear Housing; Pitman Arm Shaft Bushing)	5120-00-708-3248	7083248
63	HD	Wrench, Spanner	5120-00-118-4387	11623221
64	HD	Wrench, Worm Adjusting Bearing	5120-00-118-4402	11623222
65	HD	Wrench, Spanner	5120-00-118-4467	11623223
66	FHD	Extractor, Screw Thread Insert: Helical Insert, Flywheel Housing	5120-00-723-6833	MIL-T- 21309
67	HD	Replacing Tool, Engine: Exhaust Valve Seat Insert	5120-00-134-7480	11642006
68	FHD	Crowfoot Attachment: Used for tightening injector line nuts at injection pump head	5120-00-134-7459	11642001
69	FH	Gage Set, Pressure Dial Indicating: Fuel Pressure Test	4910-00-319-6195	5704365
70	HD	Reamer, Hand: Intake and Exhaust Valve Guides	5110-01-050-2240	12254220

## Section III. TOOL AND TEST EQUIPMENT REQUIREMENTS - Cont

(1) Reference Code	(2) Maintenance Level	(3) Nomenclature	(4) National/NATO Stock Number	(5) Tool Number
71	HD	Replacer, Valve Guide: (Used w/5120-00-871-3513 Valve Guide Remover)	5120-00-134-7461	11642004
72	HD	Bracket, Engine Mounting, Cradle: Mounting Engine, Right Front (Used with cradle 4910-00-795-0198)	4910-00-873-1923	10899191
73	HD	Bracket, Engine Mounting, Cradle: Mounting Engine, Left Front (Used with cradle 4910-00-795-0198)	4910-00-873-1924	10899173
74	FHD	Compressor, Piston: For compressing or gaging piston rings	5120-00-870-6917	10899159
75	FHD	Expander, Piston Ring	5120-00-870-6918	10899196
76	H	Kit, Remover and Replacer: Cylinder Sleeve	5120-00-448-0255	8722925
77	H	Pliers, Retaining Ring	5120-00-792-8624	10935598
78	H	Replacer, Thrust Collar or Compression: For replacing thrust collar or compressor wheel on shaft, (Used w/4910-00-870-3759 replacer)	5120-00-870-6924	10899147
79	H	Sleeve, Installing: For installing rings or thrust collar	4910-00-885-3465	10899148
80	H	Sleeve, Installing: For installing rings on shaft	4910-00-870-2122	10899149
81	H	Spacer, Clearance Checking: For checking compressor wheel back clearance	4910-00-870-2123	10899150
82	H	Support: For removing compressor wheel	4910-00-870-2124	10899152
83	H	Wrench, Box: For applying torque to housing nuts	5120-00-448-0258	8722922
84	OFHD	No. 1 Common Organizational Maintenance Tool Kit	4910-00-754-0654	SC4910- 95-CL-A74

Section III. TOOL AND TEST EQUIPMENT REQUIREMENTS - Cont

(1) Reference Code	(2) Maintenance Level	(3) Nomenclature	(4) National/NATO Stock Number	(5) Tool Number
85	OFHD	No. 1 Supplemental Organizational Maintenance Tool Kit	4910-00-754-0653	SC4910-95-CL-A73
86	OFHD	No. 2 Common Organizational Maintenance Tool Kit	4910-00-754-0650	SC4910-95-CL-A72
87	OFHD	No. 2 Supplemental Organizational Maintenance Tool Kit	4940-00-754-0743	SC4940-95-CL-A08

## Section IV. REMARKS

<u>REFERENCE CODE</u>	<u>REMARKS</u>
A	Items 72 and 73 used for the LDS 427-2 engine only.
B	Items 74, 75 and 76 used on LDS 427-2 engine only.
C	Items 77 through 83 are used on turbocharger model 4D-454C installed on LDS 427-2 engine.

By Order of the Secretaries of the Army and the Air Force:

E. C. MEYER  
General, United States Army  
Chief of Staff

Official:

J. C. PENNINGTON  
Major General, United States Army  
The Adjutant General

LEW ALLEN, JR., General, USAF  
Chief of Staff

Official:

VAN L. CRAWFORD, JR., Colonel, USAF  
Director of Administration

Distribution:

To be distributed in accordance with DA FORM 12-38, Organizational Maintenance requirements for 2-1/2 Ton Truck Cargo, 2-1/2 Ton Truck Van, etc.

RECOMMENDED CHANGES TO EQUIPMENT TECHNICAL PUBLICATIONS



THEN... JOT DOWN THE DOPE ABOUT IT ON THIS FORM, CAREFULLY TEAR IT OUT, FOLD IT AND DROP IT IN THE MAIL!

SOMETHING WRONG WITH THIS PUBLICATION?

FROM (PRINT YOUR UNIT'S COMPLETE ADDRESS)  
 CDR, 1st Bn, 65th ADA  
 Attn: SP4 Jane Idone  
 Key West, FL 33040

DATE SENT Date sent in

PUBLICATION NUMBER  
 TM 9-2320-209-20-1

PUBLICATION DATE  
 27 May 1981

PUBLICATION TITLE ORGANIZATIONAL  
 SCHEDULED MAINTENANCE MANUAL

BE EXACT - PIN-POINT WHERE IT IS

PAGE NO	PARA-GRAPH	FIGURE NO	TABLE NO
1-6			1-1
1-27			1-3
1-45		1-8	

IN THIS SPACE TELL WHAT IS WRONG AND WHAT SHOULD BE DONE ABOUT IT:

Item 5, Brake system -  
 Step 2 reads "Check that pedal (3) does not bind." Should read "Check that brake pedal (3) does not bind."

Item 6, Water segregator filter assembly -  
 refers to Vol 3, chapter 19, para 19-42.  
 Should refer to Vol 3, chapter 18, para 18-42.

Change illustration callouts.  
 Reason: callouts for "B. Rear winch" and "C. Stiff leg jacks" are reversed.

SAMPLE

PRINTED NAME GRADE OR TITLE AND TELEPHONE NUMBER

SP4 Jane Idone Autovon 222-2224

SIGN HERE

Jane Idone

FILL IN YOUR  
UNIT'S ADDRESS



FOL

DEPARTMENT OF THE ARMY

---

---

OFFICIAL BUSINESS

**SAMPLE**

TEAR ALONG PERFORATED LINE

Commander  
U.S. Army Tank-Automotive Command  
ATTN: DRSTA-MB  
Warren, MI 48090

RECOMMENDED CHANGES TO EQUIPMENT TECHNICAL PUBLICATIONS



THEN... JOT DOWN THE DOPE ABOUT IT ON THIS FORM, CAREFULLY TEAR IT OUT, FOLD IT AND DROP IT IN THE MAIL!

**SOMETHING WRONG WITH THIS PUBLICATION?**

FROM (PRINT YOUR UNIT'S COMPLETE ADDRESS)

DATE SENT

PUBLICATION NUMBER

TM 9-2320-209-20-1

PUBLICATION DATE

27 May 1981

PUBLICATION TITLE

ORGANIZATIONAL SCHEDULED MAINTENANCE MANUAL

BE EXACT PIN-POINT WHERE IT IS

PAGE NO

PARA GRAPH

FIGURE NO

TABLE NO

IN THIS SPACE TELL WHAT IS WRONG AND WHAT SHOULD BE DONE ABOUT IT:

PRINTED NAME GRADE OR TITLE AND TELEPHONE NUMBER

SIGN HERE



FILL IN YOUR  
UNIT'S ADDRESS

FOLD BACK

DEPARTMENT OF THE ARMY

OFFICIAL BUSINESS

Commander  
U.S. Army Tank-Automotive Command  
ATTN: DRSTA-MB  
Warren, MI 48090

TEAR ALONG PERFORATED LINE

## THE METRIC SYSTEM AND EQUIVALENTS

### LINEAR MEASURE

1 Centimeter = 10 Millimeters = 0.01 Meters = 0.3937 Inches  
 1 Meter = 100 Centimeters = 1000 Millimeters = 39.37 Inches  
 1 Kilometer = 1000 Meters = 0.621 Miles

### WEIGHTS

1 Gram = 0.001 Kilograms = 1000 Milligrams = 0.035 Ounces  
 1 Kilogram = 1000 Grams = 2.2 Lb  
 1 Metric Ton = 1000 Kilograms = 1 Megagram = 1.1 Short Tons

### LIQUID MEASURE

1 Milliliter = 0.001 Liters = 0.0338 Fluid Ounces  
 1 Liter = 1000 Milliliters = 33.82 Fluid Ounces

### SQUARE MEASURE

1 Sq Centimeter = 100 Sq Millimeters = 0.155 Sq Inches  
 1 Sq Meter = 10,000 Sq Centimeters = 10.76 Sq Feet  
 1 Sq Kilometer = 1,000,000 Sq Meters = 0.386 Sq Miles

### CUBIC MEASURE

1 Cu Centimeter = 1000 Cu Millimeters = 0.06 Cu Inches  
 1 Cu Meter = 1,000,000 Cu Centimeters = 35.31 Cu Feet

### TEMPERATURE

$5/9 (^{\circ}\text{F} - 32) = ^{\circ}\text{C}$   
 212° Fahrenheit is equivalent to 100° Celsius  
 90° Fahrenheit is equivalent to 32° Celsius  
 32° Fahrenheit is equivalent to 0° Celsius  
 $9/5 (^{\circ}\text{C} + 32) = ^{\circ}\text{F}$

## APPROXIMATE CONVERSION FACTORS

TO CHANGE	TO	MULTIPLY BY
Inches	Centimeters	2.540
Feet	Meters	0.305
Yards	Meters	0.914
Miles	Kilometers	1.609
Square Inches	Square Centimeters	6.451
Square Feet	Square Meters	0.093
Square Yards	Square Meters	0.836
Square Miles	Square Kilometers	2.590
Acres	Square Hectometers	0.405
Cubic Feet	Cubic Meters	0.028
Cubic Yards	Cubic Meters	0.765
Fluid	Ounces Milliliters	29.573
Pints	Liters	0.473
Quarts	Liters	0.946
Quarts	Liters	0.946
Gallons	Liters	3.785
Ounces	Grams	28.349
Pounds	Kilograms	0.45
Short Tons	Metric Tons	0.0907
Pound-Feet	Newton-Meters	1.356
Pounds per Square	Inch Kilopascals	6.895
Miles per Gallon	Kilometers per Liter	0.425
Miles per Hour	Kilometers per Hour	1.609

TO CHANGE	TO	MULTIPLY BY
Centimeters	Inches	0.394
Meters	Feet	3.280
Meters	Yards	1.094
Meters	Yards	1.094
Kilometers	Miles	0.621
Square Centimeters	Square Inches	0.155
Square Meters	Square Feet	10.764
Square Meters	Square Yards	1.195
Square Kilometers	Square Miles	0.386
Square Hectometers	Acres	2.471
Cubic Meters	Cubic Feet	35.315
Cubic Meters	Cubic Yards	1.308
Milliliters Fluid	Ounces	0.034
Liters	Pints	2.113
Liters	Quarts	1.057
Liters	Gallons	0.264
Grams	Ounces	0.035
Kilograms	Pounds	2.205
Metric Tons	Short Tons	1.102
Newton-Meters	Pound-Feet	0.738
Kilopascals	Pounds per Square Inch	0.145
Kilometers per Liter	Miles per Gallon	2.354
Kilometers per Hour	Miles per Hour	0.621

