

TM 9-2320-209-20-2-1
T.O. 36A12-1B-1092-1-2

TECHNICAL MANUAL
VOLUME 2 OF 3
PART 1 OF 2
TROUBLESHOOTING
ORGANIZATIONAL LEVEL
2½-TON, 6X6, M44A1 AND M44A2 SERIES TRUCKS
(MULTIFUEL)

TRUCK, CARGO: M35A1,
M35A2, M35A2C, M36A2; TRUCK,
TANK, FUEL: M49A1C, M49A2C; TRUCK, TANK,
WATER: M50A1, M50A2, M50A3; TRUCK, VAN,
SHOP: M109A2, M109A3; TRUCK, REPAIR SHOP:
M185A2, M185A3; TRUCK, TRACTOR: M275A1,
M275A2; TRUCK, DUMP: M342A2; TRUCK,
MAINTENANCE, PIPELINE CONSTRUCTION:
M756A2; TRUCK, MAINTENANCE,
EARTH BORING AND POLESETTING: M764

NOTE:

THE STYLE OF THIS TM IS
EXPERIMENTAL. IT IS BEING TRIED
BY THE ARMY ONLY ON
A LIMITED BASIS

DEPARTMENTS OF THE ARMY AND THE AIR FORCE
MAY 1981

WARNING

Engine cooling system runs under pressure and at very high temperatures. If filler cap is taken off before pressure is set free, scalding coolant will blow out. Due to high temperature of coolant bad burns can occur if contact is made with skin.

Do not touch any part of the exhaust system while engine is running. You can get badly burned. If the engine has just been shut off, wait until the exhaust system has time to cool down before doing any work.

Because of their higher power, 24 volt systems are more dangerous than 6 or 12 volt systems. Do not let a hot wire touch metal parts of the truck at any time. Flash testing by striking a hot wire against a ground will cause an arc that can destroy the lead connector and possibly the lead itself.

Accidental contact of metal tools between positive (+) battery or starter terminal will cause burns on the hand, damaged tools, truck electrical components and batteries. The battery can explode spraying acid and sharp fragments that can cause serious or fatal injuries.

Only properly trained personnel should perform test on 115 volt system. The voltage present in 115 volt system can cause severe or fatal electric shock.

Take off battery ground cable before working near or touching fan. This will make sure that the engine will not be started by accident. Use a rag when touching fan blades because edges on blades can cause cuts.

Eye shields must be worn when using compressed air. Eye injury can occur if eye shields are not used.

***TM 9-2320-209-20-2-1
T.O. 36A12-1B-1092-1-2**

**TECHNICAL MANUAL
NO. 9-2320-209-20-2-1
TECHNICAL ORDER
NO. 36A12-1B-1092-1-2**

**DEPARTMENTS OF THE ARMY
AND
THE AIR FORCE**

Washington, DC, 27 May 1981

**TECHNICAL MANUAL
VOLUME 2 OF 3
PART 1 OF 2
TROUBLESHOOTING
ORGANIZATIONAL LEVEL
2½-TON, 6x6, M44A1 AND M44A2 SERIES TRUCKS
(MULTIFUEL)**

Model		NSN without Winch	NSN with Winch
Truck, Cargo	M35A1	2320-00-542-5633	2320-00-542-5634
	M35A2	2320-00-077-1616	2320-00-077-1617
	M35A2C	2320-00-926-0873	2320-00-926-0875
	M36A2	2320-00-077-1618	2320-00-077-1619
Truck, Tank, Fuel	M49A1C	2320-00-440-3349	2320-00-440-3346
	M49A2C	2320-00-077-1631	2320-00-077-1632
Truck, Tank, Water	M50A1	2320-00-440-8307	2320-00-440-8305
	M50A2	2320-00-077-1633	2320-00-077-1634
	M50A3	2320-00-937-4036	2320-00-937-5264
Truck, Van, Shop	M109A2	2320-00-440-8313	2320-00-440-8308
	M109A3	2320-00-077-1636	2320-00-077-1637
Truck, Repair Shop	M185A2	4940-00-987-8799	
	M185A3	4940-00-077-1638	4940-00-077-1639
Truck, Tractor	M275A1	2320-00-446-2479	
	M275A2	2320-00-077-1640	2320-00-077-1641
Truck, Dump	M342A2	2320-00-077-1643	2320-00-077-1644
Truck, Maintenance, Pipeline Construction	M756A2		2320-00-904-3277
Truck, Maintenance, Earth Boring and Polesetting	M764		2320-00-937-5980

*This manual, together with TM 9-2320-209-20-1, 27 May 1981; TM 9-2320-209-20-2, 27 May 1981; TM 9-2320-209-20-3-1, 27 May 1981; TM 9-2320-209-20-3-2, 27 May 1981; TM 9-2320-209-20-3-3, 27 May 1981; and TM 9-2320-209-20-3-4, 27 May 1981, supersedes TM 9-2320-209-20-1, 31 August 1978.

REPORTING OF ERRORS AND RECOMMENDING IMPROVEMENTS

You can help improve this manual. If you find any mistake or if you know of a way to improve the procedure, please let us know. Mail your letter, DA Form 2028 (Recommended Changes to Publication and Blank Forms), or DA Form 2028-2 located in the back of this manual direct to: Commander, U.S. Army Tank Automotive Materiel Readiness Command, ATTN: DRSTA-MBT, Warren, Michigan 48090. A reply will be furnished to you.

TABLE OF CONTENTS

	Paragraph	Page
CHAPTER 1. GENERAL INFORMATION		
Scope.....	1-1	1-1
Organization.....	1-2	1-1
Troubleshooting Approach.....	1-3	1-1
CHAPTER 2. TROUBLESHOOTING APPROACH		
General Approach.....	2-1	2-1
Troubleshooting Index	2-2	2-1
Test Equipment Procedures Index.....	2-3	2-1
Troubleshooting Roadmaps	2-4	2-1
Fault Symptom Index.....	2-5	2-1
Sample Troubleshooting Procedure	2-6	2-1
CHAPTER 3. TROUBLESHOOTING INDEX		
General	3-1	3-1
Index	3-2	3-1
CHAPTER 4. TEST EQUIPMENT PROCEDURES INDEX		
General	4-1	4-1
Index	4-2	4-1
CHAPTER 5. TROUBLESHOOTING ROADMAPS		
General	5-1	5-1
Roadmaps	5-2	5-1
CHAPTER 6. FAULT SYMPTOM INDEXES		
General	6-1	6-1
Indexes	6-2	6-1
CHAPTER 7. SAMPLE TROUBLESHOOTING PROCEDURE		
General	7-1	7-1
Sample Detailed Procedure	7-2	7-1
Sample Test Equipment Procedure.....	7-3	7-1
Sample Summary Troubleshooting Procedures	7-4	7-2
CHAPTER 8. ENGINE SYSTEM TROUBLESHOOTING		
Equipment Items Covered	8-1	8-1
Equipment Items Not Covered	8-2	8-1
CHAPTER 9. ENGINE SYSTEM TROUBLESHOOTING SUMMARY		
General	9-1	9-1
Procedures	9-2	9-1

TABLE OF CONTENTS-CONT

		Paragraph	Page
CHAPTER 10.	ENGINE DRIVELINE SUBSYSTEM TROUBLESHOOTING		
	Equipment Items Covered		10-1
	Equipment Items Not Covered	10-2	10-1
CHAPTER 11.	CLUTCH SYSTEM TROUBLESHOOTING		
	Equipment Items Covered	11-1	11-1
	Equipment Items Not Covered	11-2	11-1
CHAPTER 12.	CLUTCH SYSTEM TROUBLESHOOTING SUMMARY		
	General	12-1	12-1
	Procedures	12-2	12-1
CHAPTER 13.	FUEL SYSTEM TROUBLESHOOTING		
	Equipment Items Covered	13-1	13-1
	Equipment Items Not Covered	13-2	13-1
CHAPTER 14.	FUEL SYSTEM TROUBLESHOOTING SUMMARY		
	General	14-1	14-1
	Procedures	14-2	14-1
CHAPTER 15.	FUEL SYSTEM SUPPORT DIAGRAMS		
	General	15-1	15-1
CHAPTER 16.	FUEL SYSTEM TEST PROCEDURES		
	General	16-1	16-1
	Test Set-up	16-2	16-1
	Test Procedure	16-3	16-1
CHAPTER 17.	EXHAUST SYSTEM TROUBLESHOOTING		
	Equipment Items Covered	17-1	17-1
	Equipment Items Not Covered	17-2	17-1
CHAPTER 18.	EXHAUST SYSTEM TROUBLESHOOTING SUMMARY		
	General	18-1	18-1
	Procedures	18-2	18-1
CHAPTER 19.	EXHAUST SYSTEM SUPPORT DIAGRAMS		
	General	19-1	19-1
CHAPTER 20.	COOLING SYSTEM TROUBLESHOOTING		
	Equipment Items Covered	20-1	20-1
	Equipment Items Not Covered	20-2	20-1
CHAPTER 21.	COOLING SYSTEM TROUBLESHOOTING SUMMARY		
	General	21-1	21-1
	Procedures	21-2	21-1
CHAPTER 22.	COOLING SYSTEM SUPPORT DIAGRAMS		
	General	22-1	22-1
CHAPTER 23.	COOLING SYSTEM TEST PROCEDURES		
	General	23-1	23-1
	Test Set-Up	23-2	23-1
	Test Procedure	23-3	23-1

TABLE OF CONTENTS-CONT

		Paragraph	Page
CHAPTER 24.	COOLING SYSTEM CHECKOUT PROCEDURES		
	General	24-1	24-1
CHAPTER 25.	ELECTRICAL SYSTEM TROUBLESHOOTING		
	Equipment Items Covered	25-1	25-1
	Equipment Items Not Covered	25-2	25-1
PART 2 OF 2 (TM 9-2320-209-20-2-2)			
CHAPTER 26.	ELECTRICAL SYSTEM TROUBLESHOOTING SUMMARY		
	General	26-1	26-1
	Procedures	26-2	26-1
CHAPTER 27.	ELECTRICAL SYSTEM SUPPORT DIAGRAMS		
	General	27-1	27-1
CHAPTER 28.	MULTIMETER TEST PROCEDURES		
	General	28-1	28-1
	Test Set-Up	28-2	28-1
	Test Procedure	28-3	28-1
CHAPTER 29.	OPERATING AND PRELIMINARY PROCEDURES		
	Equipment Items Covered	29-1	29-1
	Equipment Items Not Covered	29-2	29-1
CHAPTER 30.	ELECTRICAL SYSTEM CHECKOUT PROCEDURES		
	General	30-1	30-1
CHAPTER 31.	TRANSMISSION SYSTEM TROUBLESHOOTING		
	Equipment Items Covered	31-1	31-1
	Equipment Items Not Covered	31-2	31-1
CHAPTER 32.	TRANSMISSION SYSTEM TROUBLESHOOTING SUMMARY		
	General	32-1	32-1
	Procedures	32-2	32-1
CHAPTER 33.	TRANSFER SYSTEM TROUBLESHOOTING		
	Equipment Items Covered	33-1	33-1
	Equipment Items Not Covered	33-2	33-1
CHAPTER 34.	TRANSFER SYSTEM TROUBLESHOOTING SUMMARY		
	General	34-1	34-1
	Procedures	34-2	34-1
CHAPTER 35.	TRANSFER SYSTEM CHECKOUT PROCEDURES		
	General	35-1	35-1
CHAPTER 36.	PROPELLER SHAFT SYSTEM TROUBLESHOOTING		
	Equipment Items Covered	36-1	36-1
	Equipment Items Not Covered	36-2	36-1
CHAPTER 37.	PROPELLER SHAFT SYSTEM TROUBLE- SHOOTING SUMMARY		
	General	37-1	37-1
	Procedures	37-2	37-1

TABLE OF CONTENTS-CONT

	Paragraph	Page
CHAPTER 38. PROPELLER SHAFT SYSTEM SUPPORT DIAGRAMS		
General	38-1	38-1
CHAPTER 39. FRONT AXLE SYSTEM TROUBLESHOOTING		
Equipment Items Covered	39-1	39-1
Equipment Items Not Covered	39-2	39-1
CHAPTER 40. FRONT AXLE SYSTEM TROUBLESHOOTING SUMMARY		
General	40-1	40-1
Procedures	40-2	40-1
CHAPTER 41. FRONT AXLE SYSTEM CHECKOUT PROCEDURES		
General	41-1	41-1
CHAPTER 42. REAR AXLE SYSTEM TROUBLESHOOTING		
Equipment Items Covered	42-1	42-1
Equipment Items Not Covered	42-2	42-1
CHAPTER 43. REAR AXLE SYSTEM SUPPORT DIAGRAMS		
General	43-1	43-1
CHAPTER 44. BRAKE SYSTEM TROUBLESHOOTING		
Equipment Items Covered	44-1	44-1
Equipment Items Not Covered	44-2	44-1
CHAPTER 45. BRAKE SYSTEM TROUBLESHOOTING SUMMARY		
General	45-1	45-1
Procedures	45-2	45-1
CHAPTER 46. BRAKE SYSTEM SUPPORT DIAGRAMS		
General	46-1	46-1
CHAPTER 47. HANDBRAKE SUBSYSTEM TROUBLESHOOTING		
Equipment Items Covered	47-1	47-1
Equipment Items Not Covered	47-2	47-1
CHAPTER 48. COMPRESSED AIR SUBSYSTEM TROUBLESHOOTING		
Equipment Items Covered	48-1	48-1
Equipment Items Not Covered	48-2	48-1
CHAPTER 49. BRAKE SYSTEM TEST PROCEDURES		
General	49-1	49-1
Test Set-Up	49-2	49-1
Test Procedure	49-3	49-1
CHAPTER 50. BRAKE SYSTEM CHECKOUT PROCEDURES		
General	50-1	50-1
CHAPTER 51. WHEEL SYSTEM TROUBLESHOOTING		
Equipment Items Covered	51-1	51-1
Equipment Items Not Covered	51-2	51-1
CHAPTER 52. STEERING SYSTEM TROUBLESHOOTING		
Equipment Items Covered	52-1	52-1
Equipment Items Not Covered	52-2	52-1
CHAPTER 53. STEERING SYSTEM TROUBLESHOOTING SUMMARY		
General	53-1	53-1
Procedures	53-2	53-1
CHAPTER 54. STEERING SYSTEM SUPPORT DIAGRAMS		
General	54-1	54-1

TABLE OF CONTENTS-CONT

		Paragraph	Page
CHAPTER 55.	SPRING AND SHOCK ABSORBERS SYSTEM TROUBLESHOOTING		
	Equipment Items Covered	55-1	55-1
	Equipment Items Not Covered	55-2	55-1
CHAPTER 56.	SPRING AND SHOCK ABSORBERS SYSTEM TROUBLESHOOTING SUMMARY		
	General.....	56-1	56-1
	Procedures	56-2	56-1
CHAPTER 57.	DUMP BODY TROUBLESHOOTING		
	Equipment Items Covered	57-1	57-1
	Equipment Items Not Covered	57-2	57-1
CHAPTER 58.	DUMP BODY TROUBLESHOOTING SUMMARY		
	General	58-1	58-1
	Procedures	58-2	58-1
CHAPTER 59.	DUMP BODY SUPPORT DIAGRAMS		
	General	59-1	59-1
CHAPTER 60.	DUMP BODY CHECKOUT PROCEDURES		
	General	60-1	60-1
CHAPTER 61.	WATER TANK BODY TROUBLESHOOTING		
	Equipment Items Covered	61-1	61-1
	Equipment Items Not Covered	61-2	61-1
CHAPTER 62.	WATER TANK BODY TROUBLESHOOTING SUMMARY		
	General	62-1	62-1
	Procedures	62-2	62-1
CHAPTER 63.	WATER TANK BODY SUPPORT DIAGRAMS		
	General	63-1	63-1
CHAPTER 64.	WATER TANK BODY CHECKOUT PROCEDURES		
	General	64-1	64-1
CHAPTER 65.	FUEL TANK BODY (TRUCK M49A1C) TROUBLESHOOTING		
	Equipment Items Covered	65-1	65-1
	Equipment Items Not Covered	65-2	65-1
CHAPTER 66.	FUEL TANK BODY (TRUCK M49A1C) TROUBLESHOOTING SUMMARY		
	General	66-1	66-1
	Procedures	66-2	66-1
CHAPTER 67.	FUEL TANK BODY (TRUCK M49A1C) SUPPORT DIAGRAMS		
	General	67-1	67-1
CHAPTER 68.	FUEL TANK BODY (TRUCK M49A1C) CHECKOUT PROCEDURES		
	General	68-1	68-1

TABLE OF CONTENTS-CONT

		Paragraph	Page
CHAPTER 69.	FUEL TANK BODY (TRUCK M49A2C) TROUBLESHOOTING		
	Equipment Items Covered	69-1	69-1
	Equipment Items Not Covered	69-2	69-1
CHAPTER 70.	FUEL TANK BODY (TRUCK M49A2C) TROUBLESHOOTING SUMMARY		
	General	70-1	70-1
	Procedures	70-2	70-1
CHAPTER 71.	FUEL TANK BODY (TRUCK M49A2C) SUPPORT DIAGRAMS		
	General	71-1	71-1
CHAPTER 72.	FUEL TANK BODY (TRUCK M49A2C) CHECKOUT PROCEDURES		
	General	72-1	72-1
CHAPTER 73.	EARTH BORING MACHINE TROUBLESHOOTING		
	Equipment Items Covered	73-1	73-1
	Equipment Items Not Covered	73-2	73-1
CHAPTER 74.	EARTH BORING MACHINE TROUBLE- SHOOTING SUMMARY		
	General	74-1	74-1
	Procedures	74-2	74-1
CHAPTER 75.	EARTH BORING MACHINE SUPPORT DIAGRAMS		
	General	75-1	75-1
CHAPTER 76.	EARTH BORING MACHINE CHECKOUT PROCEDURES		
	General	76-1	76-1
CHAPTER 77.	FRONT WINCH TROUBLESHOOTING		
	Equipment Items Covered	77-1	77-1
	Equipment Items Not Covered	77-2	77-1
CHAPTER 78.	FRONT WINCH TROUBLESHOOTING SUMMARY		
	General	78-1	78-1
	Procedures	78-2	78-1
CHAPTER 79.	FRONT WINCH CHECKOUT PROCEDURES		
	General	79-1	79-1
CHAPTER 80.	EARTH BORING MACHINE REAR WINCH TROUBLESHOOTING		
	Equipment Items Covered	80-1	80-1
	Equipment Items Not Covered	80-2	80-1
CHAPTER 81.	PIPELINE CONSTRUCTION TRUCK REAR WINCH TROUBLESHOOTING		
	Equipment Items Covered	81-1	81-1
	Equipment Items Not Covered	81-2	81-1

TABLE OF CONTENTS-CONT

		Paragraph	Page
CHAPTER 82.	ENGINE COOLANT HEATER TROUBLE- SHOOTING		
	Equipment Items Covered	82-1	82-1
	Equipment Items Not Covered.	82-2	82-1
CHAPTER 83.	ENGINE COOLANT HEATER TROUBLE- SHOOTING SUMMARY		
	General	83-1	83-1
	Procedures	83-2	83-1
CHAPTER 84.	ENGINE COOLANT HEATER SUPPORT DIAGRAMS		
	General	84-1	84-1
CHAPTER 85.	ENGINE COOLANT HEATER TEST PROCEDURES		
	General	85-1	85-1
	Test Set-Up	85-2	85-1
	Test Procedure	85-3	85-1
CHAPTER 86.	ENGINE COOLANT HEATER CHECKOUT PROCEDURES		
	General	86-1	86-1
CHAPTER 87.	FUEL BURNING PERSONNEL HEATER TROUBLESHOOTING		
	Equipment Items Covered	87-1	87-1
	Equipment Items Not Covered	87-2	87-1
CHAPTER 88.	FUEL BURNING PERSONNEL HEATER TROUBLESHOOTING SUMMARY		
	General	88-1	88-1
	Procedures	88-2	88-1
CHAPTER 89.	FUEL BURNING PERSONNEL HEATER SUPPORT DIAGRAMS		
	General	89-1	89-1
CHAPTER 90.	FUEL BURNING PERSONNEL HEATER CHECKOUT PROCEDURES		
	General	90-1	90-1
CHAPTER 91.	HOT WATER HEATER TROUBLESHOOTING		
	Equipment Items Covered	91-1	91-1
	Equipment Items Not Covered.	91-2	91-1
CHAPTER 92.	HOT WATER HEATER TROUBLESHOOTING SUMMARY		
	General	92-1	92-1
	Procedures	92-2	92-1
CHAPTER 93.	HOT WATER HEATER CHECKOUT PROCEDURES		
	General	93-1	93-1
CHAPTER 94.	DEEP WATER FORDING KIT TROUBLE- SHOOTING		
	Equipment Items Covered	94-1	94-1
	Equipment Items Not Covered	94-2	94-1

TABLE OF CONTENTS-CONT

		Paragraph	Page
CHAPTER 95.	DEEP WATER FORDING KIT TROUBLE- SHOOTING SUMMARY		
	General	95-1	95-1
	Procedures	95-2	95-1
CHAPTER 96.	DEEP WATER FORDING KIT SUPPORT DIAGRAMS		
	General	96-1	96-1
CHAPTER 97.	DEEP WATER FORDING KIT CHECKOUT PROCEDURES		
	General	97-1	97-1
CHAPTER 98.	NONELECTRICAL GAGES TROUBLESHOOTING		
	Equipment Items Covered	98-1	98-1
	Equipment Items Not Covered	98-2	98-1
CHAPTER 99.	NONELECTRICAL GAGES TROUBLESHOOTING SUMMARY		
	General	98-1	98-1
	Procedures.....	99-2	99-1
CHAPTER 100.	NONELECTRICAL GAGES SUPPORT DIAGRAMS		
	General	100-1	100-1

CHAPTER 1

GENERAL INFORMATION

1-1. SCOPE. This volume tells you how to do troubleshooting at the organizational level of maintenance. The amount of troubleshooting you can do is based on what the Maintenance Allocation Chart says you can fix. Because of this, the only trouble symptoms you will find here are those that could be caused by faulty things you can fix .

1-2. ORGANIZATION. This volume has the information you will need to troubleshoot the truck. Chapter 2 tells you how to use the information in the other chapters of this volume to find what is wrong with the truck, and what you must do to fix it. Chapter 7 has a procedure that takes you step-by-step through a sample troubleshooting procedure and shows you how to use the information to find the trouble and fix it.

1-3. TROUBLESHOOTING APPROACH . In order to find out what is causing the problem in the truck, you must use a good approach. A good approach just means a way of doing troubleshooting so you can find the problem and not get confused or lost. The following chapter describes how you can use the materials in this volume to troubleshoot with a good approach.

CHAPTER 2

TROUBLESHOOTING APPROACH

2-1. GENERAL APPROACH. This chapter gives you instructions on how to use the troubleshooting material to help you find and fix the trouble. In every system of the truck there can be faults or problems which will cause certain symptoms. Symptoms can be such things as unusual noise, vibration, or even complete failure of a system. This volume gives information for each system on which you can do troubleshooting to find faults and fix them. Before you troubleshoot a system, you should look at the troubleshooting indexes which will lead you to the information you need to help make your troubleshooting faster and easier. If you follow the instructions the right way, you will find those troubles you can fix. But, if you fix something and the trouble is still there, it means there is more than one trouble. If this happens, start all over again to find the other trouble.

2-2. TROUBLESHOOTING INDEX. The troubleshooting index, and instructions on how to use it are in chapter 3. Go to this index first because it tells you where to find troubleshooting roadmaps, fault symptom indexes, summary troubleshooting charts and support diagrams for each system.

2-3. TEST EQUIPMENT PROCEDURES INDEX . The test equipment procedures index, and instructions on how to use it are in chapter 4. This index tells you where to find electrical and mechanical tests which you can use to do your troubleshooting. It also tells you what equipment you will need to do the tests. If you have a STE/ICE (Simplified Test Equipment/Internal Combustion Engine) Set (NSN 4910-00-124-2554), you may use it, where applicable, to do your troubleshooting. Refer to TM 9-4910-571-12 & P.

2-4. TROUBLESHOOTING ROADMAPS. Troubleshooting roadmaps for each system are in chapter 5. If the system is made up of subsystems, these subsystems are also on the roadmap. Under the subsystem is a list of things which are the most likely causes of a fault symptom in that subsystem. If you have enough skill, you can troubleshoot these things on the truck without using the detailed troubleshooting procedures. So if you know enough about the truck to work on your own, use the roadmap for the system with the problem before you check the fault symptom index.

2-5. FAULT SYMPTOM INDEX. Fault symptom indexes and instructions on how to use them are in chapter 6. For each system of the truck, there is an index which gives you a list of the fault symptoms for that system. The index also tells you where to find the detailed troubleshooting procedures and what resources (tools/people) you need to do each procedure.

2-6. SAMPLE TROUBLESHOOTING PROCEDURE. A sample troubleshooting procedure is in chapter 7. This sample procedure will help you see the way detailed troubleshooting procedures are to be used.

CHAPTER 3

TROUBLESHOOTING INDEX

3-1. GENERAL. This chapter has a troubleshooting index which covers every system of the truck on which you can do troubleshooting. The index tells you where to find all the other information you need to do your troubleshooting procedures.

3-2. INDEX. The troubleshooting index (fig. 3-1) is divided into five columns that list systems, troubleshooting roadmaps, fault symptoms, summary troubleshooting procedures, and system support diagrams. The following breakdown tells you what is in each column.

a. System Column. This column gives a list of systems on the truck for which troubleshooting can be done at the organizational maintenance level.

b. Troubleshooting Roadmaps Column. This column tells you where to find the troubleshooting roadmap for each listed system. These roadmaps are given in chapter 5.

c. Fault Symptom Index Column. This column tells you where to find the troubleshooting fault symptom index for each listed system. Fault symptom indexes are given in chapter 6.

d. Summary Troubleshooting Procedures Column. This column tells you where to find the summary troubleshooting procedure for each listed system. Some systems do not have summary troubleshooting procedures, so the column will be left blank for those systems.

e. System Support Diagrams Column. This column tells you where to find support diagrams for each listed system. Some systems do not have support diagrams, so the column will be left blank for those systems.

SYSTEM		TROUBLE-SHOOTING ROADMAPS	FAULT SYMPTOM INDEXES	SUMMARY TROUBLE-SHOOTING PROCEDURES	SYSTEM SUPPORT DIAGRAMS
1	ENGINE	Figure 5-1	Table 6-1	Figure 9-1	
2	CLUTCH	Figure 5-2	Table 6-2	Figure 12-1	
3	FUEL	Figure 5-3	Table 6-3	Figure 14-1	Figure 15-1
4	EXHAUST	Figure 5-4	Table 6-4	Figure 18-1	Figure 19-1
5	COOLING	Figure 5-5	Table 6-5	Figure 21-1	Figure 22-1
6	ELECTRICAL	Figure 5-6	Table 6-6	Figure 26-1	Figure 27-1
7	TRANSMISSION	Figure 5-7	Table 6-7	Figure 32-1	
8	TRANSFER	Figure 5-8	Table 6-8	Figure 34-1	
9	PROPELLER SHAFT	Figure 5-9	Table 6-9	Figure 37-1	Figure 38-1
10	FRONT AXLE	Figure 5-10	Table 6-10	Figure 40-1	
11	REAR AXLE	Figure 5-11	Table 6-11		Figure 43-1
12	BRAKES	Figure 5-12	Table 6-12	Figure 45-1	Figure 46-1
13	WHEELS	Figure 5-13	Table 6-13		
14	STEERING	Figure 5-14	Table 6-14	Figure 53-1	Figure 54-1
15	SPRINGS AND SHOCK ABSORBERS	Figure 5-15	Table 6-15	Figure 56-1	
16	DUMP BODY	Figure 5-16	Table 6-16	Figure 58-1	Figure 59-1
17	WATER TANK BODY	Figure 5-17	Table 6-17	Figure 62-1	Figure 63-1
18	FUEL TANK BODY M49A1C	Figure 5-18	Table 6-18	Figure 66-1	Figure 67-1
19	FUEL TANK BODY M49A2C	Figure 5-19	Table 6-19	Figure 70-1	Figure 71-1
20	EARTH BORING MACHINE M764	Figure 5-20	Table 6-20	Figure 74-1	Figure 75-1
21	FRONT WINCH	Figure 5-21	Table 6-21	Figure 78-1	
22	EARTH BORING MACHINE REAR	Figure 5-22	Table 6-22		
	WINCH				
23	PIPELINE CONSTRUCTION TRUCK	Figure 5-23	Table 6-23		
	REAR WINCH				
24	ENGINE COOLANT HEATER	Figure 5-24	Table 6-24	Figure 83-1	Figure 84-1
25	FUEL BURNING PERSONNEL HEATER	Figure 5-25	Table 6-25	Figure 88-1	Figure 89-1
26	HOT WATER HEATER	Figure 5-26	Table 6-26	Figure 92-1	
27	DEEP WATER FORDING KIT	Figure 5-27	Table 6-27	Figure 95-1	Figure 96-1
28	NON ELECTRICAL GAGES	Figure 5-28	Table 6-28	Figure 99-1	Figure 100-1

TA 115210

Figure 3-1. Troubleshooting Index

CHAPTER 4

TEST EQUIPMENT PROCEDURES INDEX

4-1. GENERAL. This chapter has a test equipment procedures index which tells you where to find the tests you need to do your troubleshooting.

4-2. INDEX. The test equipment procedures index is divided into three columns that list test equipment, tests, and figure numbers. The following breakdown tells you what is in each column.

a. Test Equipment Column. This column tells you what kind of equipment you need to do your troubleshooting tests. For all electrical tests, a multimeter is used. The multimeter can be any one of three models fielded for your use. These models are given in the test equipment column. For mechanical tests, test equipment is also given, along with the part number of the equipment.

b. Tests Column. This column tells you what tests are given in this manual. Next to each piece of test equipment are listed the tests that you can do with that equipment. This column also gives troubleshooting tests which can be done without using test equipment.

c. Figure Column. This column tells you where you can find the tests in this manual. The first test given is the DC Voltage test. The figures given for this test are 28-2, 28-8, and 28-14. Three figures are given for each multimeter test because there are three multimeter models.

TEST EQUIPMENT		TESTS	FIGURE
1	MULTIMETER AN/URM-105C SIMPSON 160 TS-352B/U	1. DC Voltage	28-2,28-8,28-14
		2. AC Voltage	28-3,28-9,28-15
		4. Continuity	28-5,28-11,28-17
		5. Short	28-6,28-12,28-18
2	GAGE-fuel system pressure P/N 11600036	Fuel Tank Pump Pressure	16-5
		Flame Heater Fuel Pump	16-1
		Fuel Filter Body	16-2
		Flame Heater Nozzle	16-3
		Fuel Lines and Fittings	16-4
		Thermostat	23-1
		Compressed Air Lines Leakage	49-1
		Master Cylinder Leakage	49-2
		Air Governor Adjustment	49-3
		Hoist Control Linkage	57-6
		Hoist Control Box	57-7
		Control Linkage Woodroof	57-8
		Keyed Shaft	
		Heater Fuel Line Clog	85-1
		Heater Fuel Pump	85-2

Figure 4-1. Test Equipment Procedures Index

TA 115211

CHAPTER 5

TROUBLESHOOTING ROADMAPS

5-1. GENERAL. This chapter gives troubleshooting roadmaps for every system of the truck for which you have detailed troubleshooting procedures. Figures 5-1 through 5-28 cover all the roadmaps for the detailed procedures.

5-2. ROADMAPS. Each roadmap gives a list of things which are most likely to cause a fault symptom in a system or subsystem. At least one of the items listed will be found to be bad when you do the detailed troubleshooting procedures for that system.

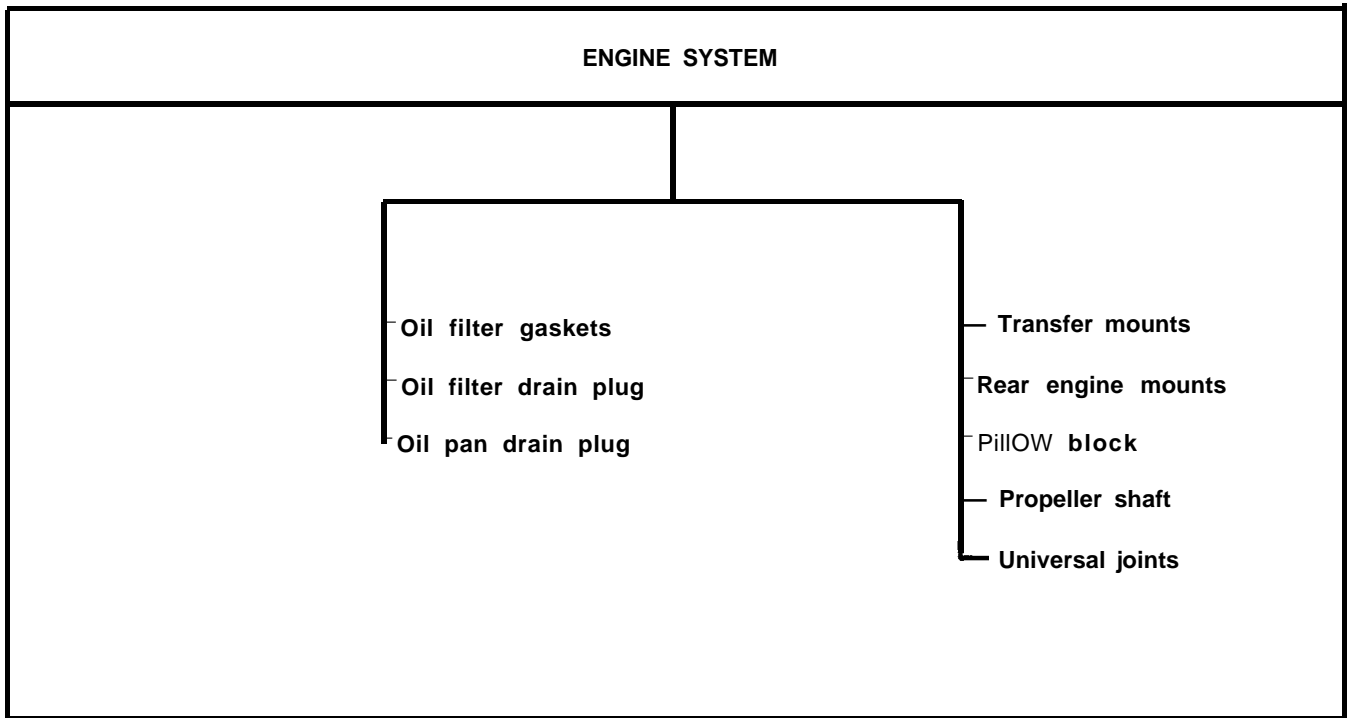

Figure 5-1. Troubleshooting Roadmap, Engine System

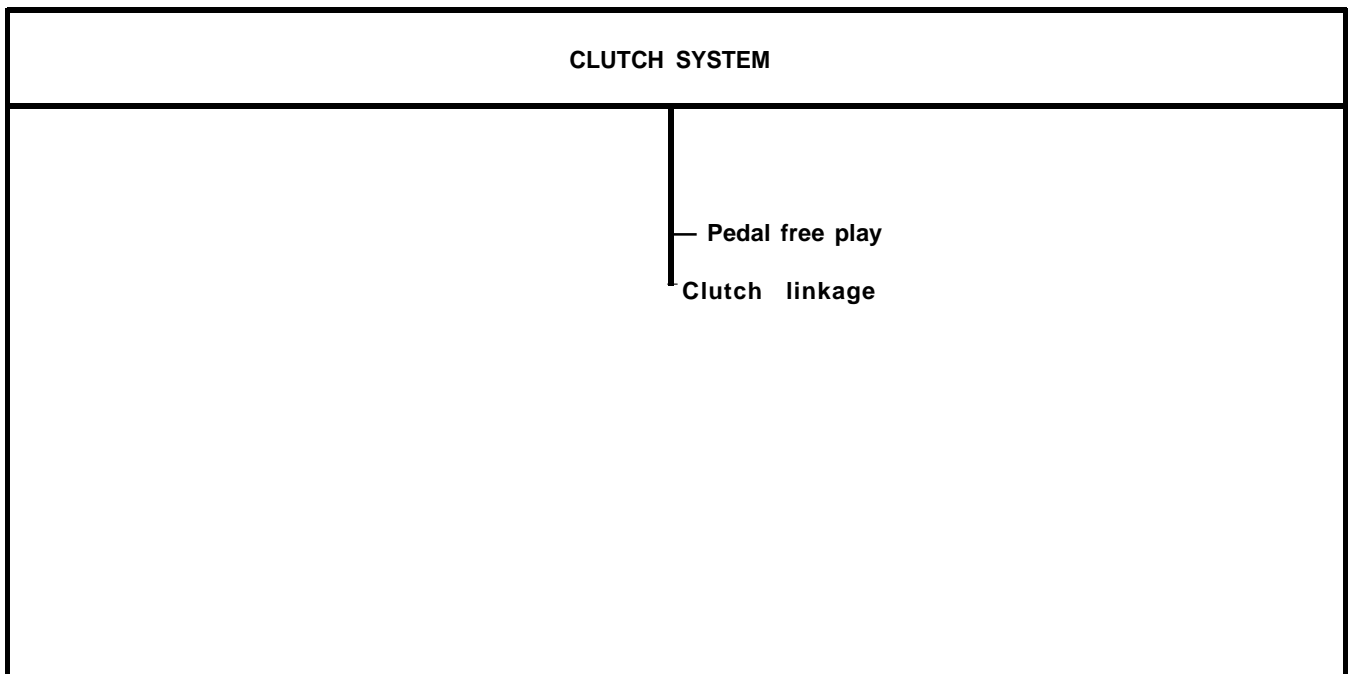

Figure 5-2. Troubleshooting Roadmap, Clutch System

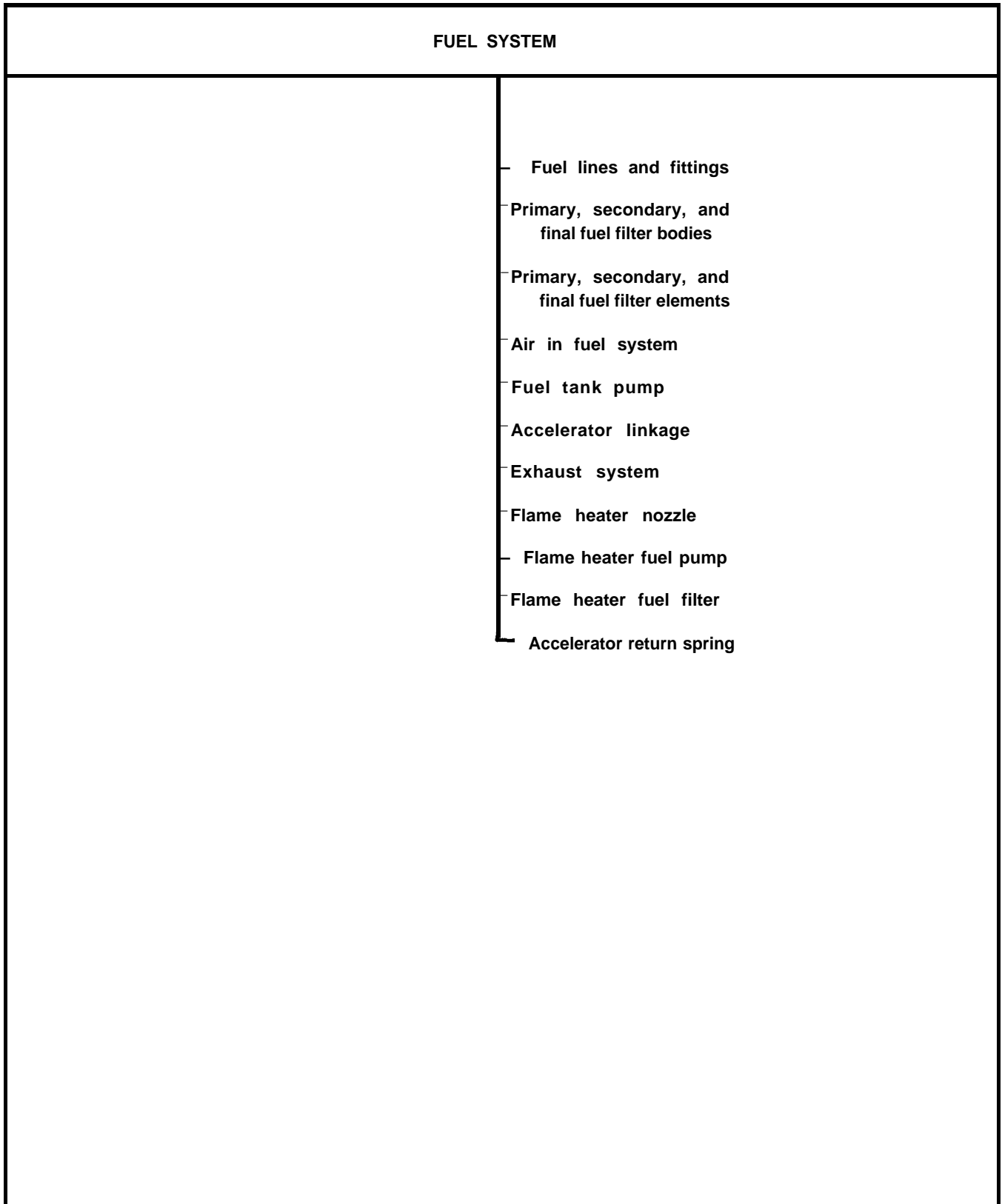

Figure 5-3. Troubleshooting Roadmap, Fuel System

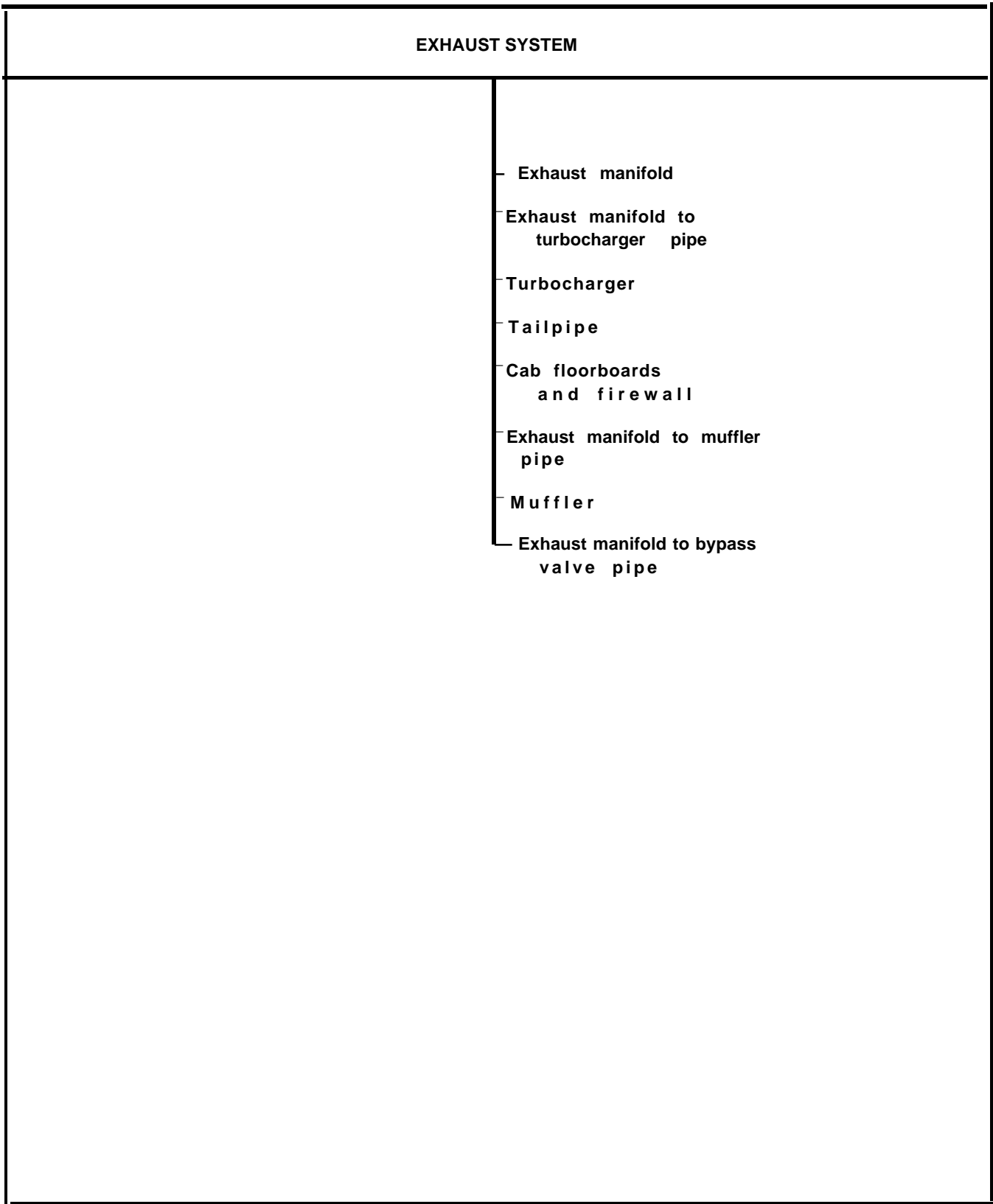

Figure 5-4. Troubleshooting Roadmap, Exhaust System

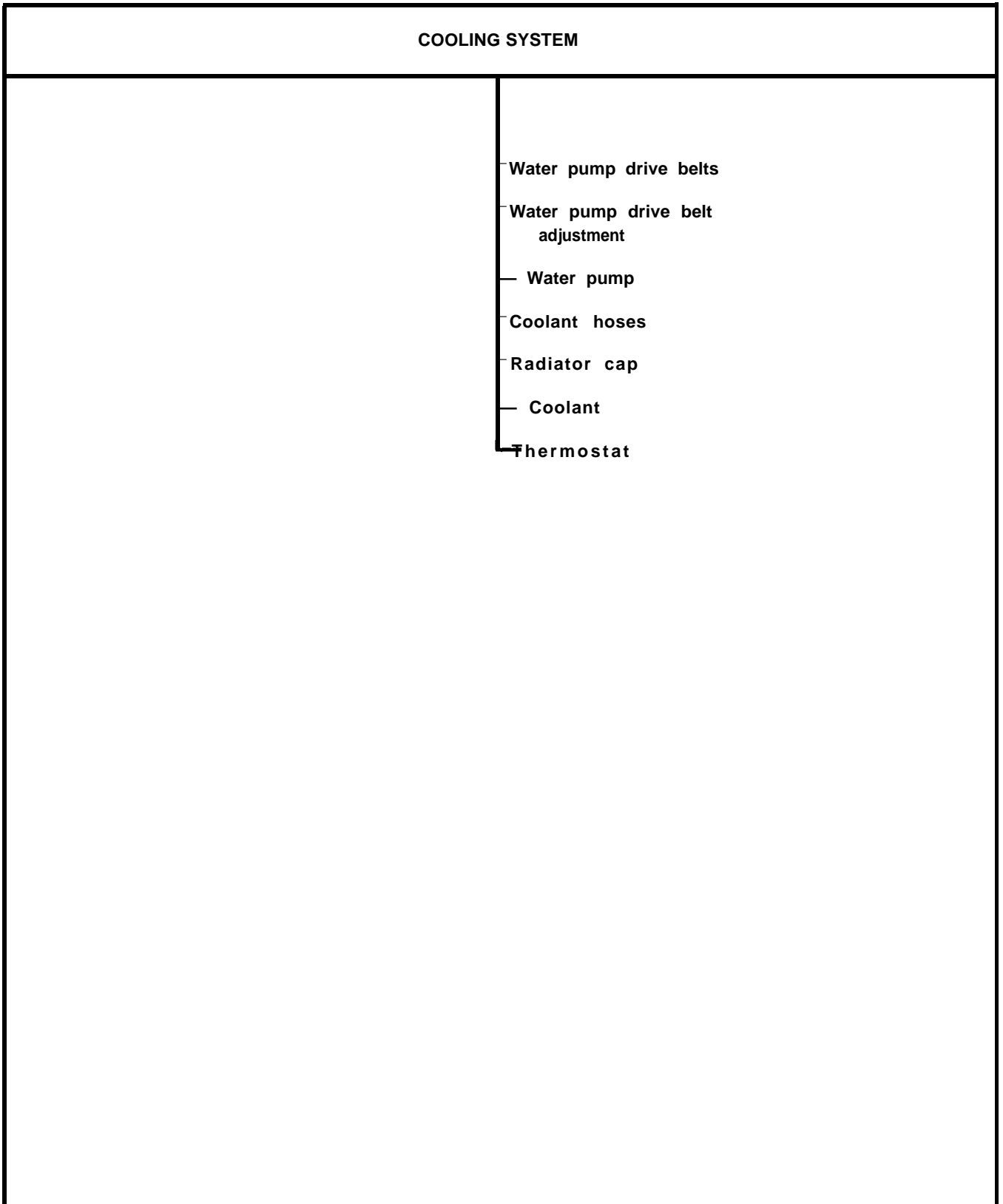

Figure 5-5. Troubleshooting Roadmap, Cooling System

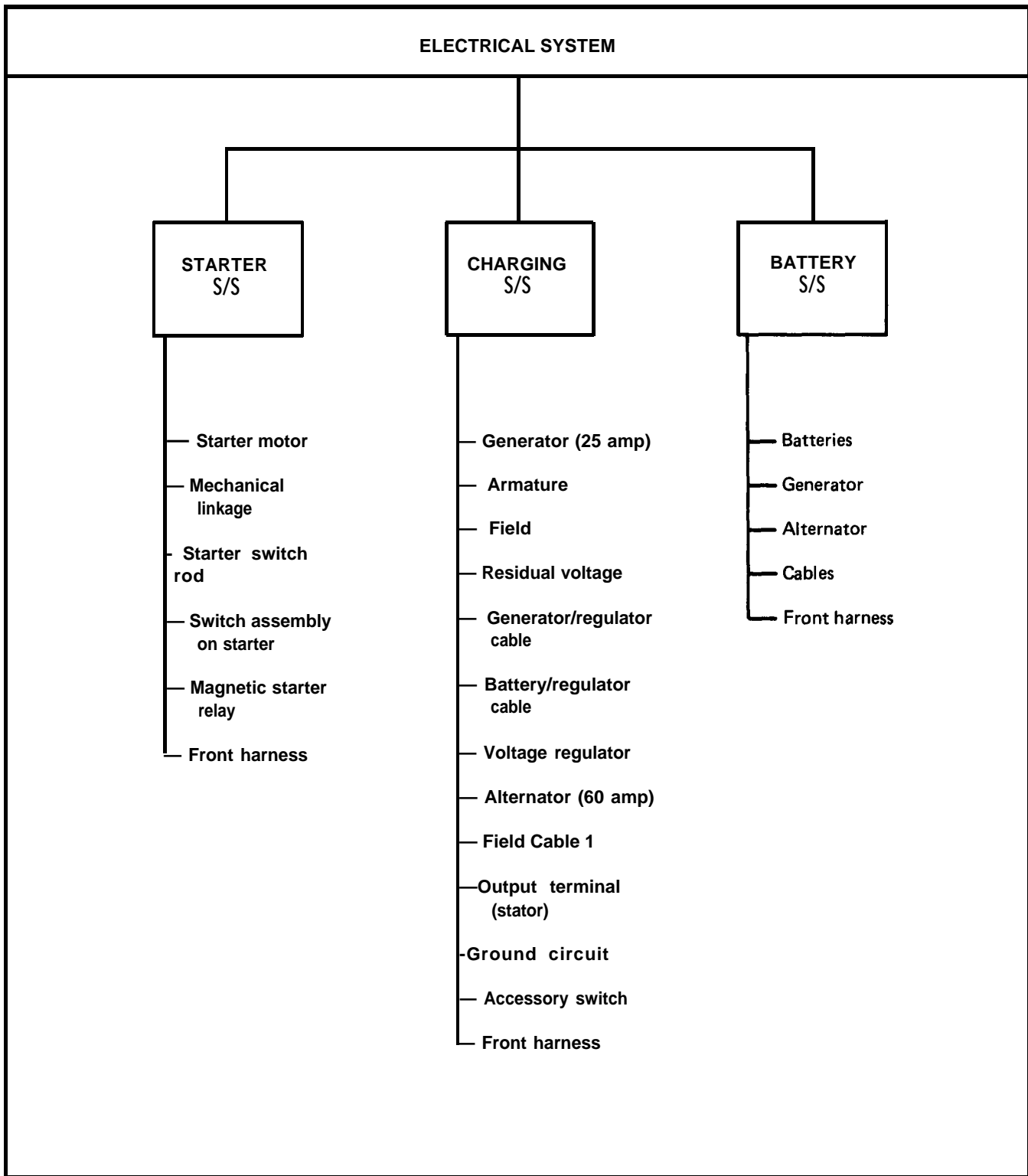

Figure 5-6. Troubleshooting Roadmap, Electrical System (Sheet 1 of 5)

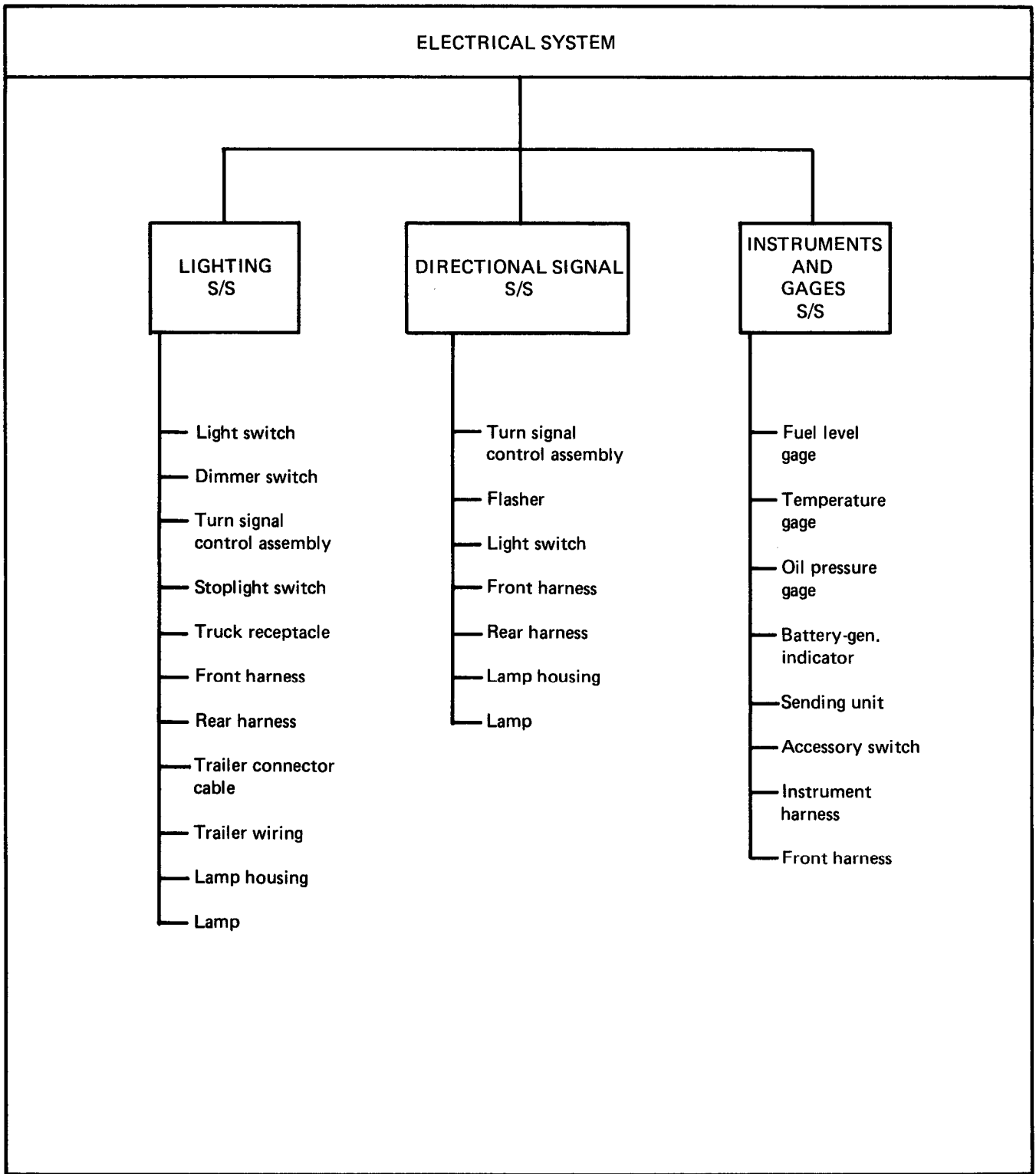

Figure 5-6. Troubleshooting Roadmap, Electrical System (Sheet 2 of 5)

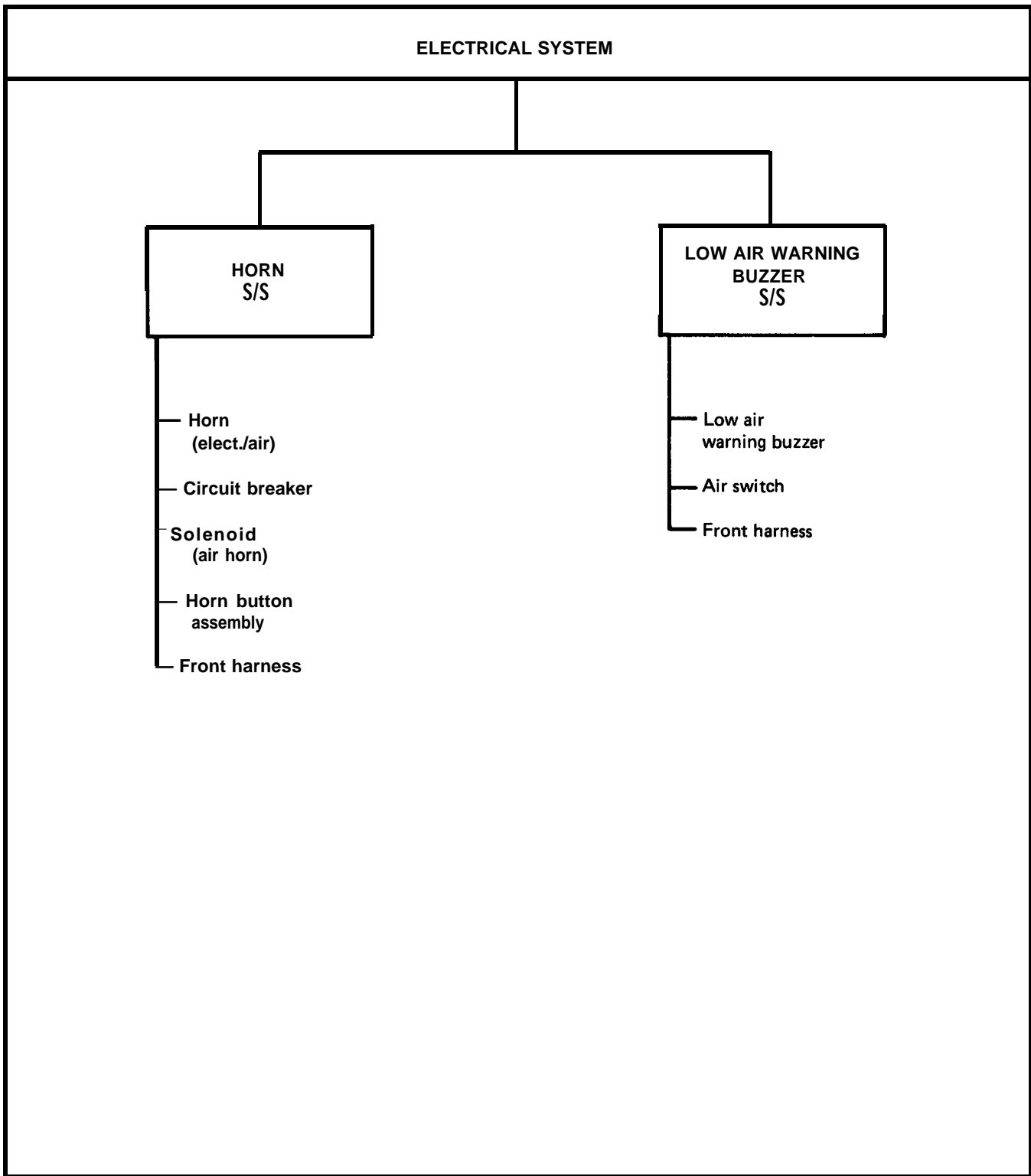

Figure 5-6. Troubleshooting Roadmap, Electrical System (Sheet 3 of 5)

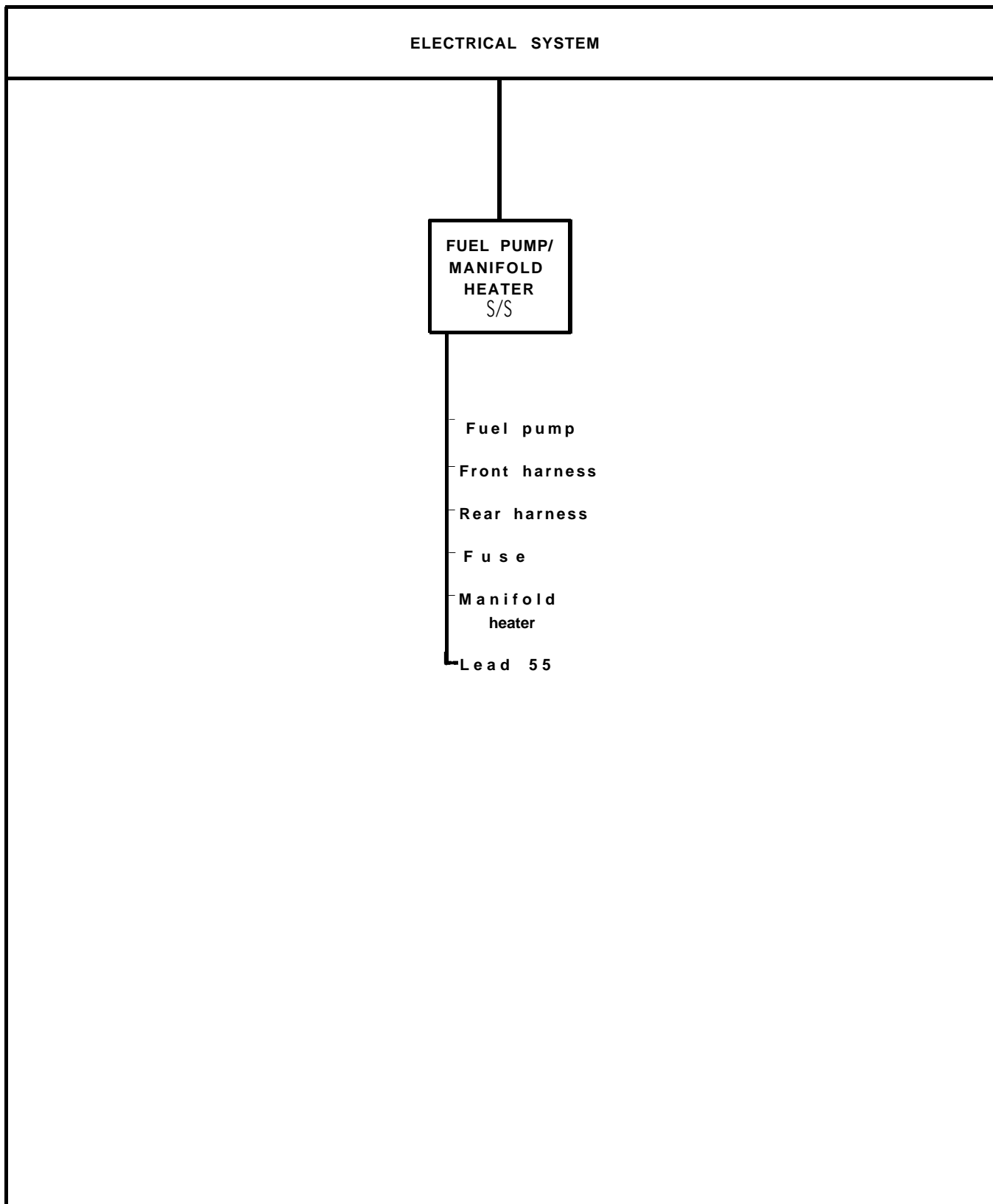

Figure 5-6. Troubleshooting Roadmap, Electrical System (Sheet 4 of 5)

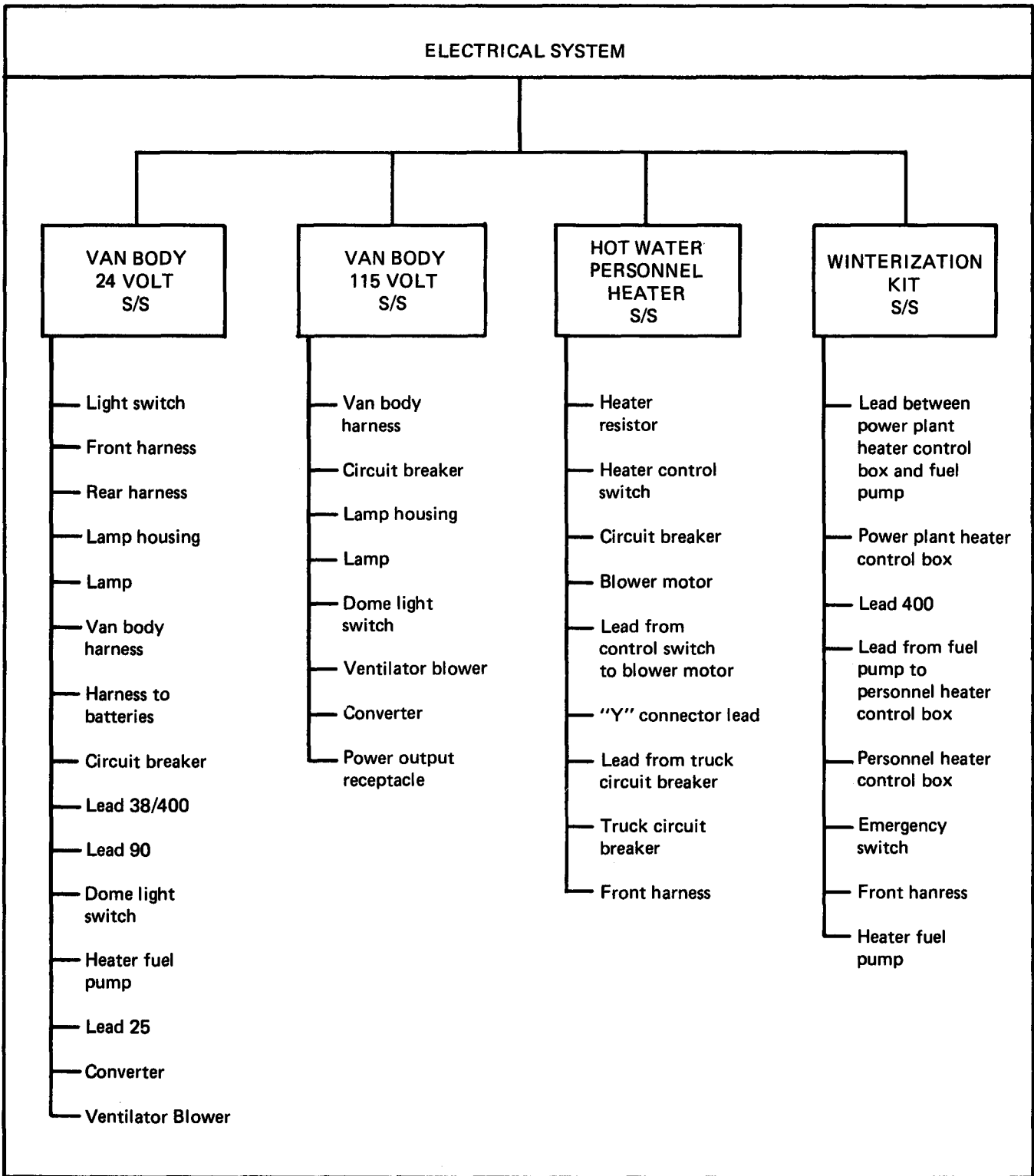

Figure 5-6. Troubleshooting Roadmap, Electrical System (Sheet 5 of 5)

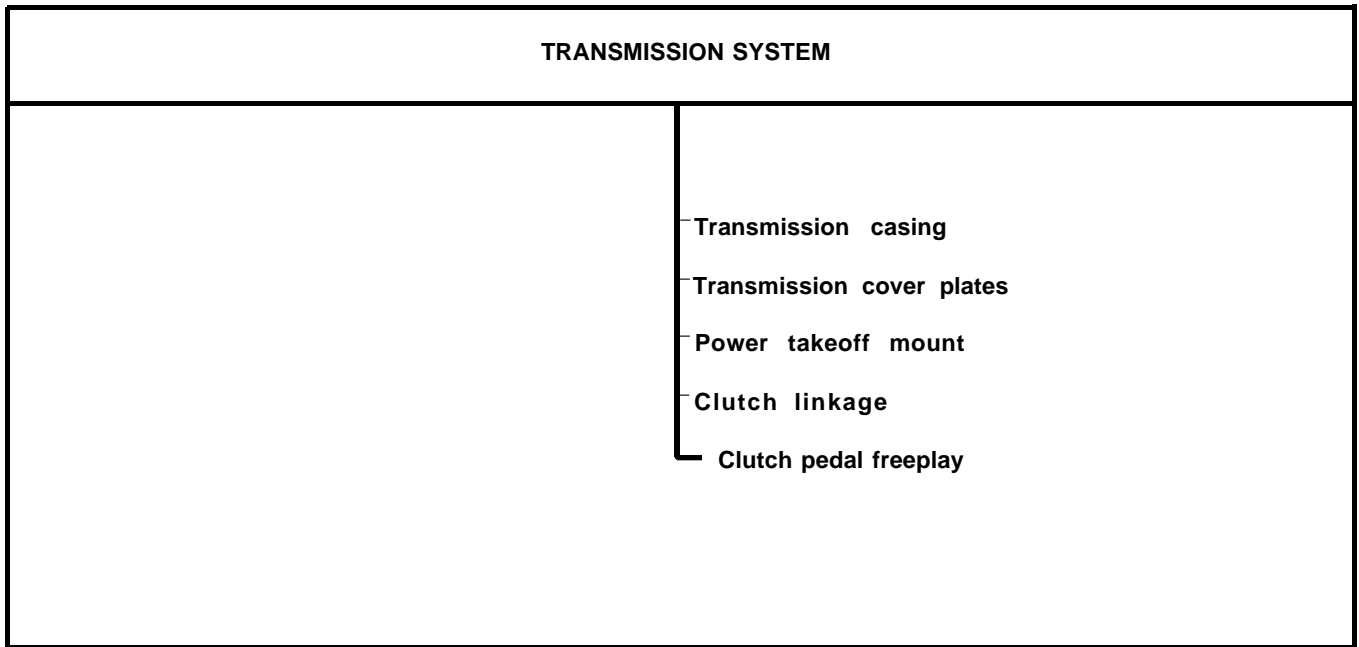

Figure 5-7. Troubleshooting Roadmap, Transmission System

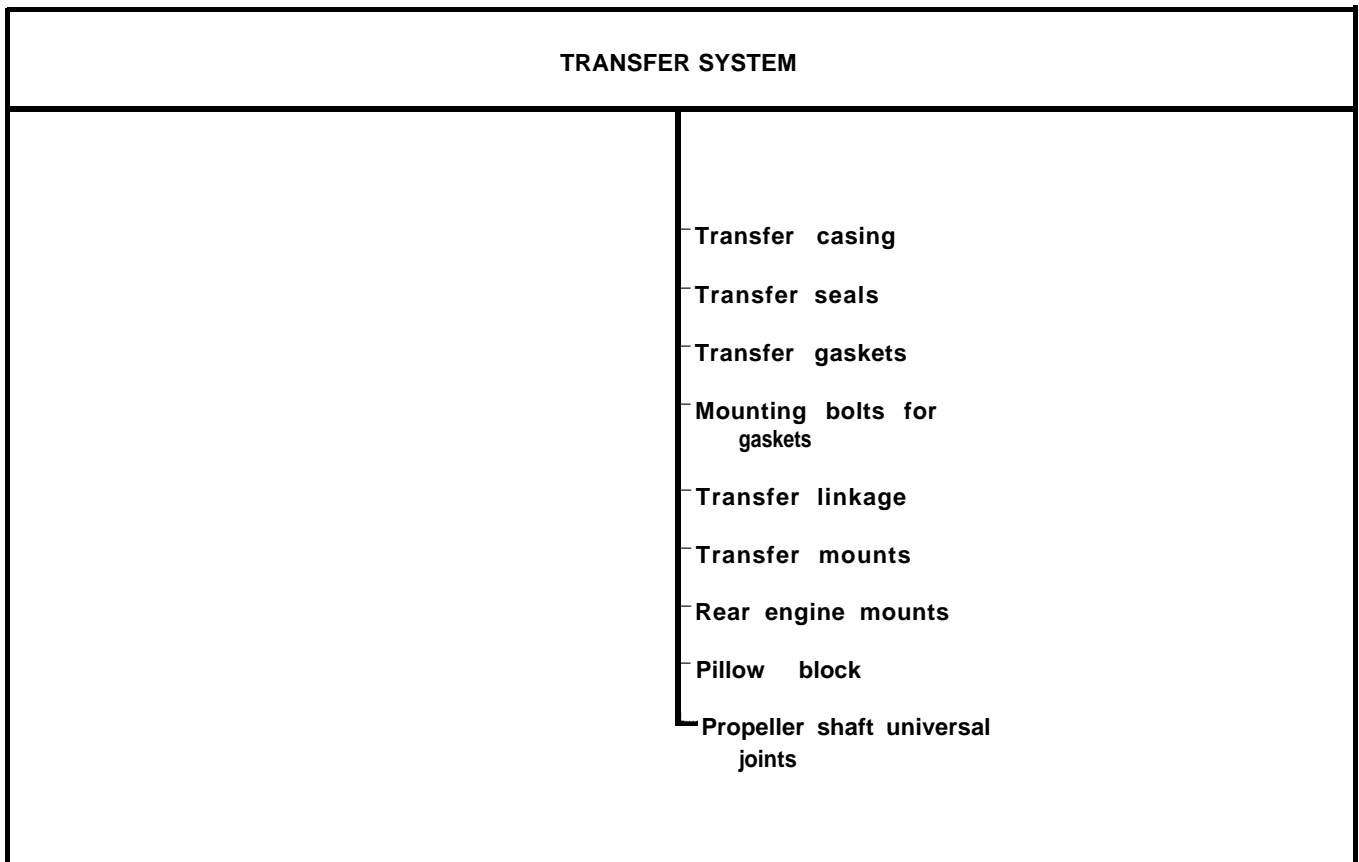

Figure 5-8. Troubleshooting Roadmap, Transfer System

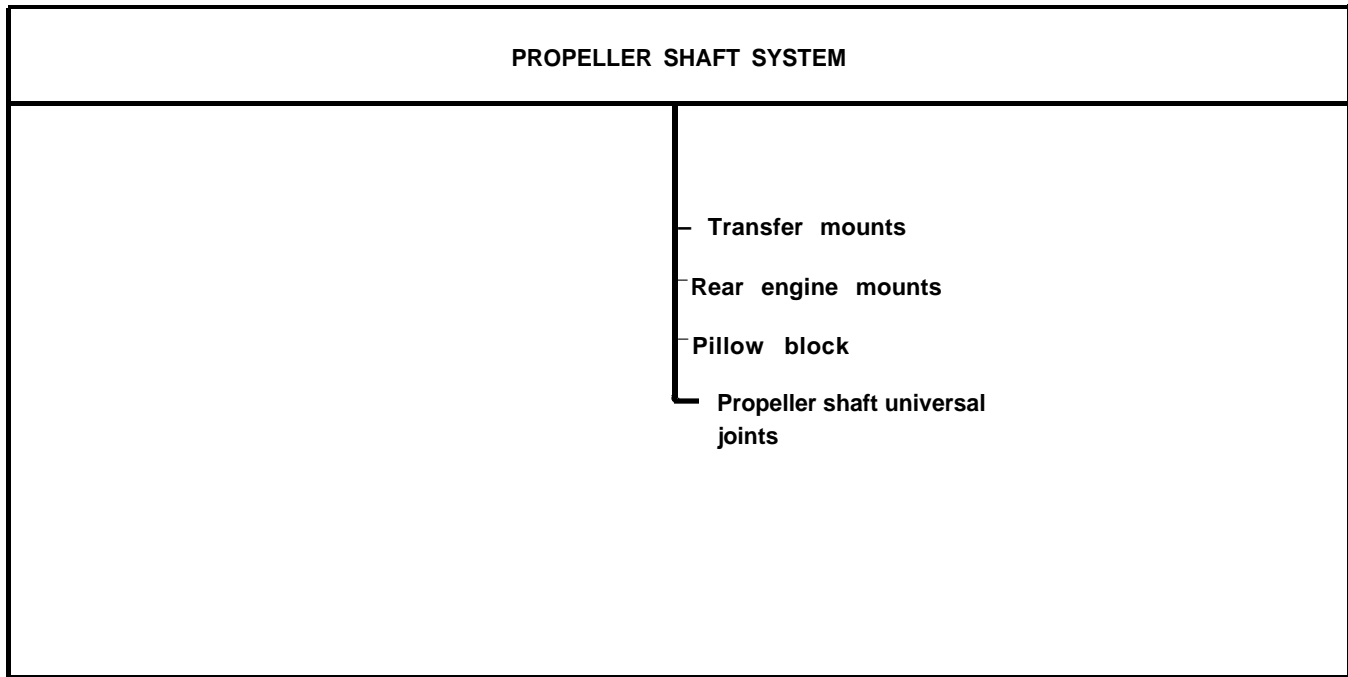

Figure 5-9. Troubleshooting Roadmap, Propeller Shaft System

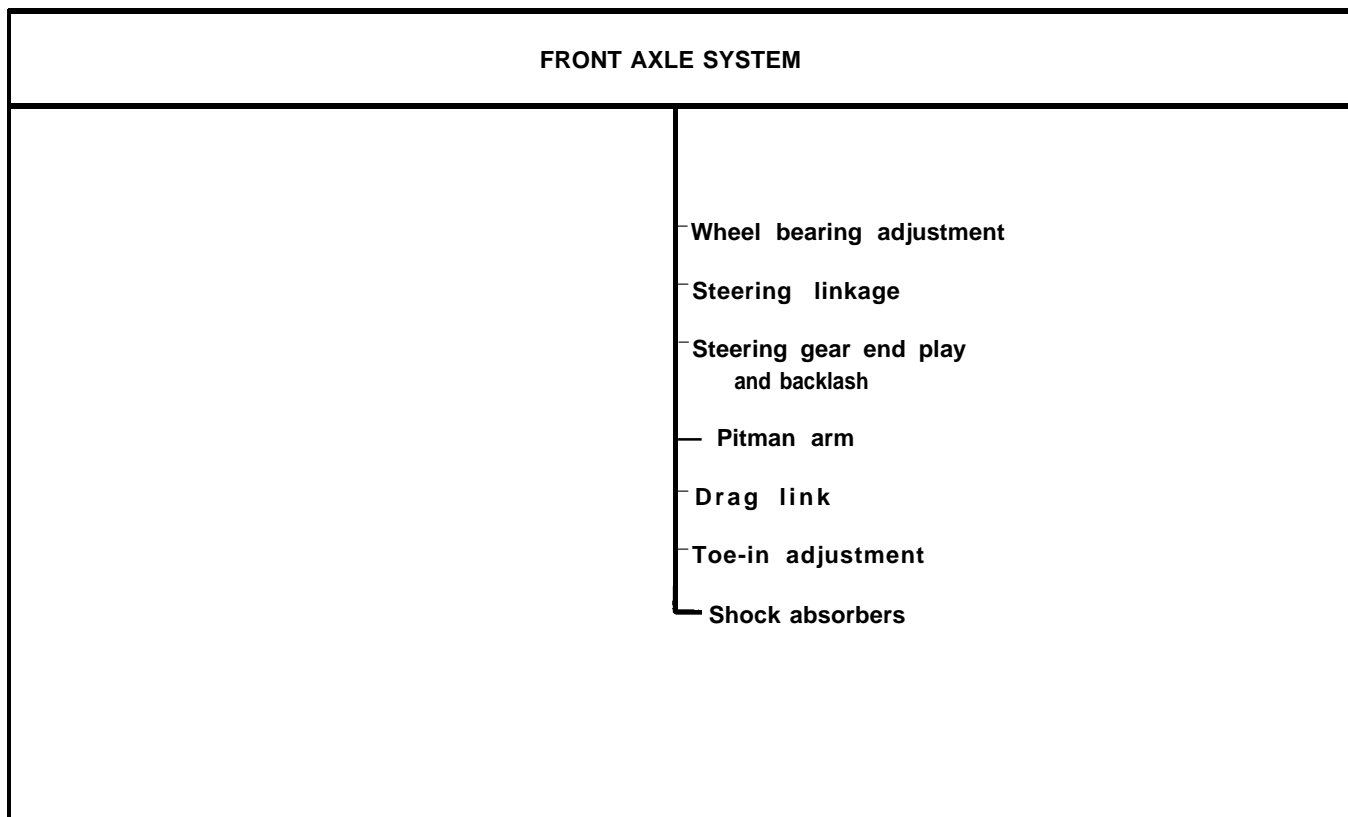

Figure 5-10. Troubleshooting Roadmap, Front Axle System

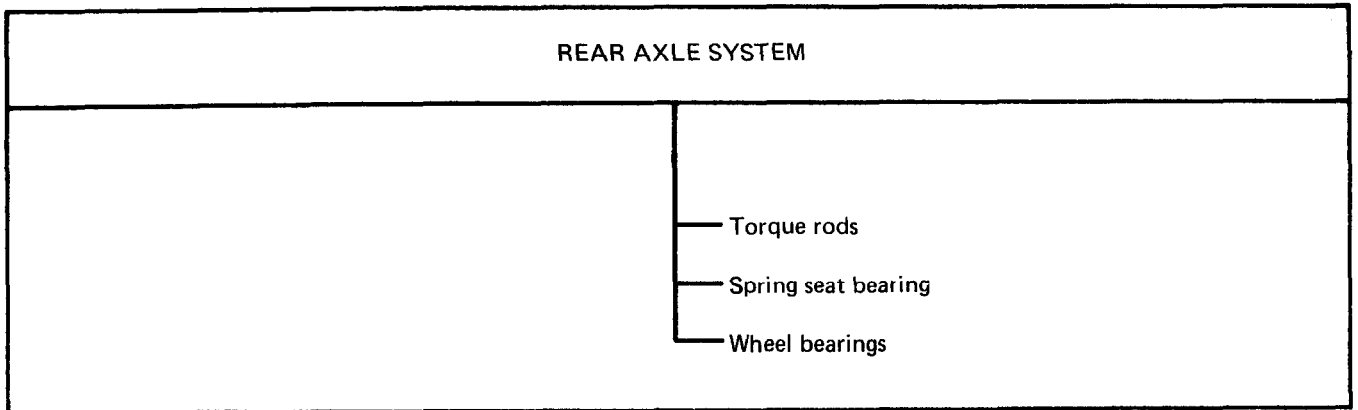

Figure 5-11. Troubleshooting Roadmap, Rear Axle System

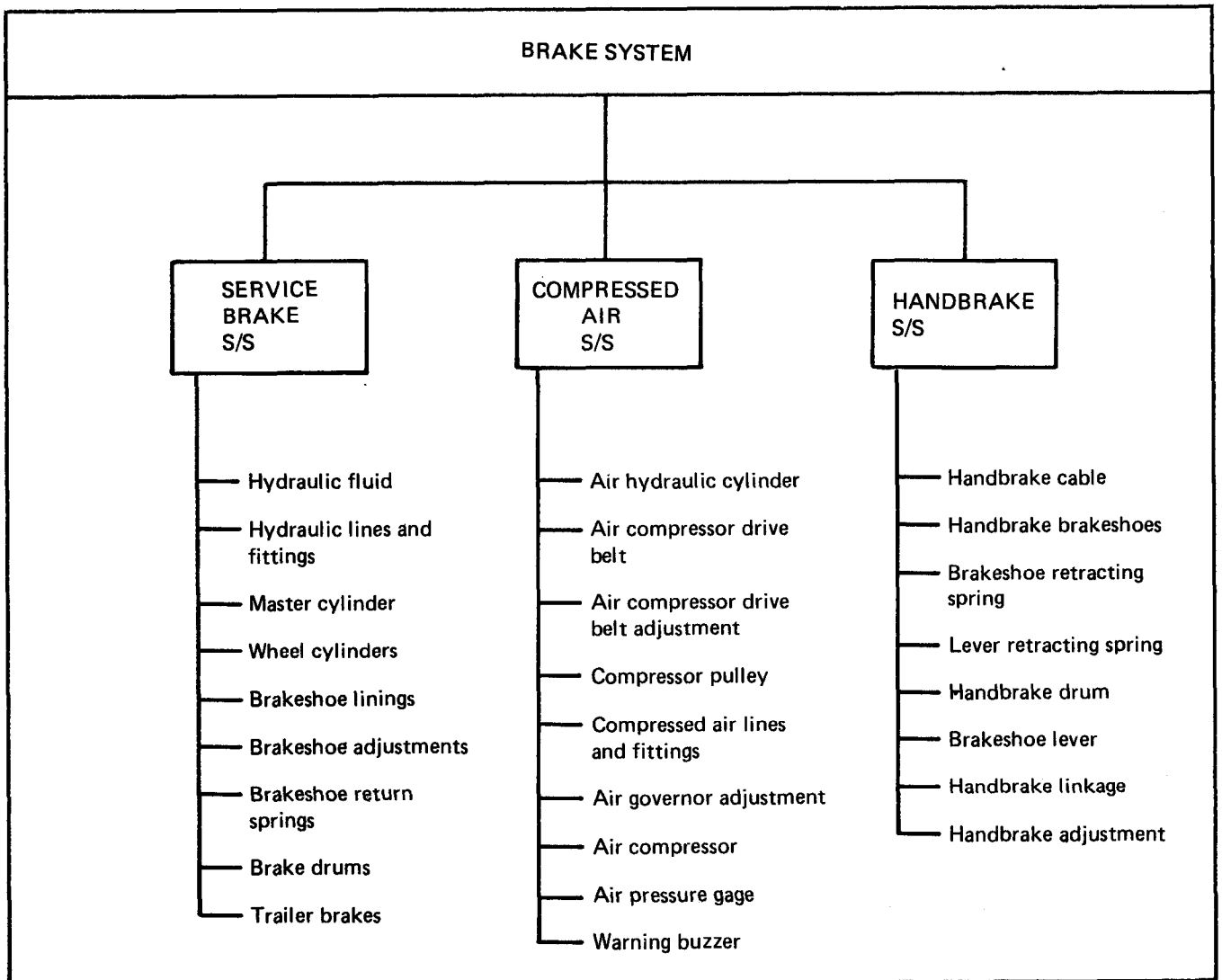

Figure 5-12. Troubleshooting Roadmap, Brake System

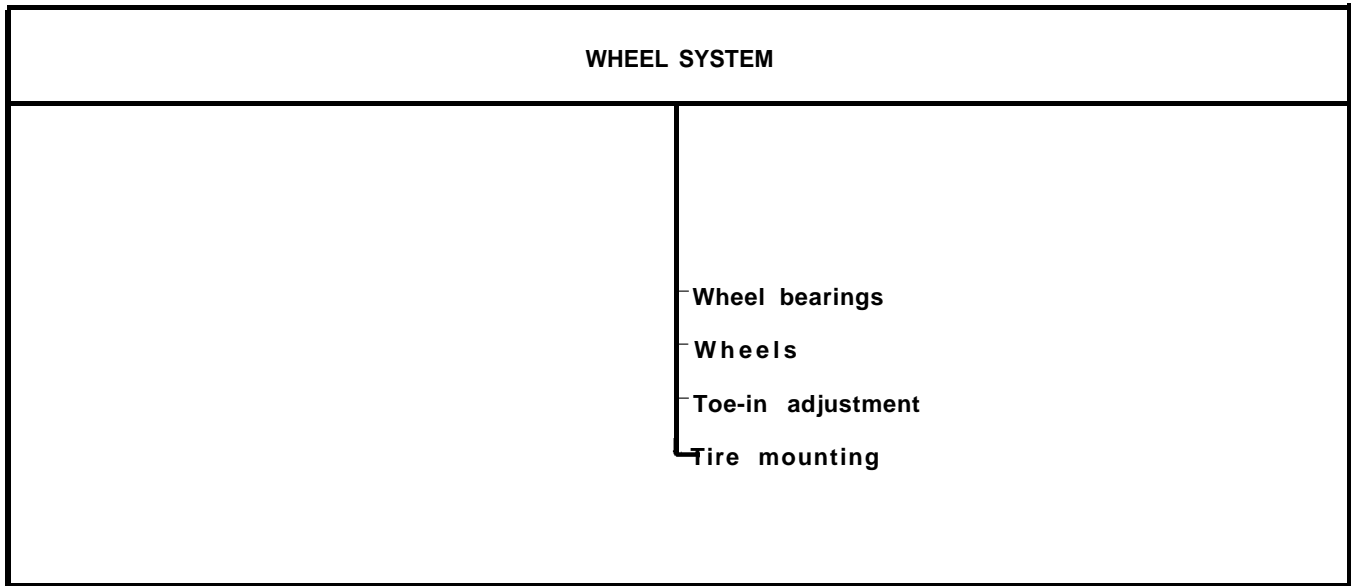

Figure 5-13. Troubleshooting Roadmap, Wheel System

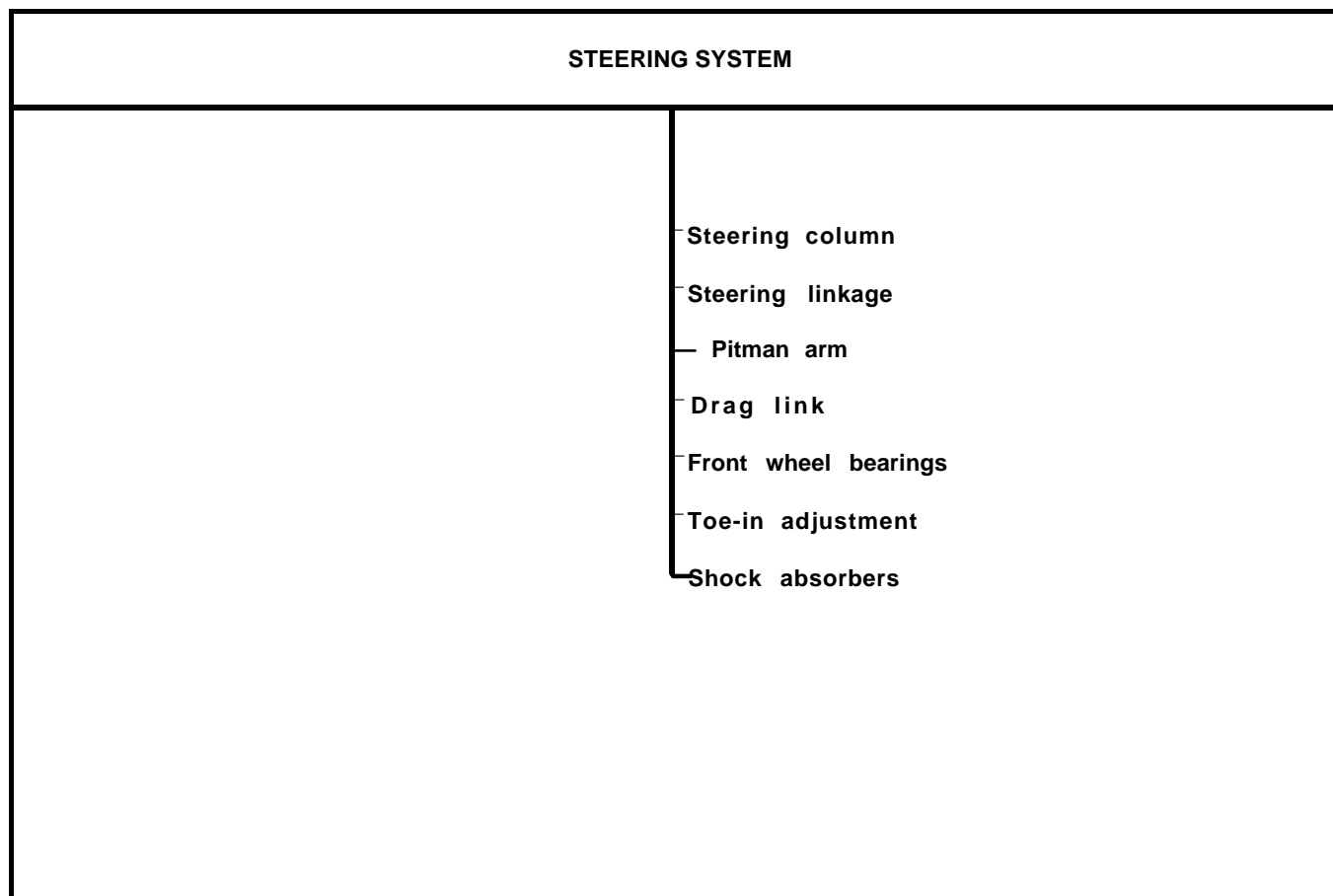

Figure 5-14. Troubleshooting Roadmap, Steering System

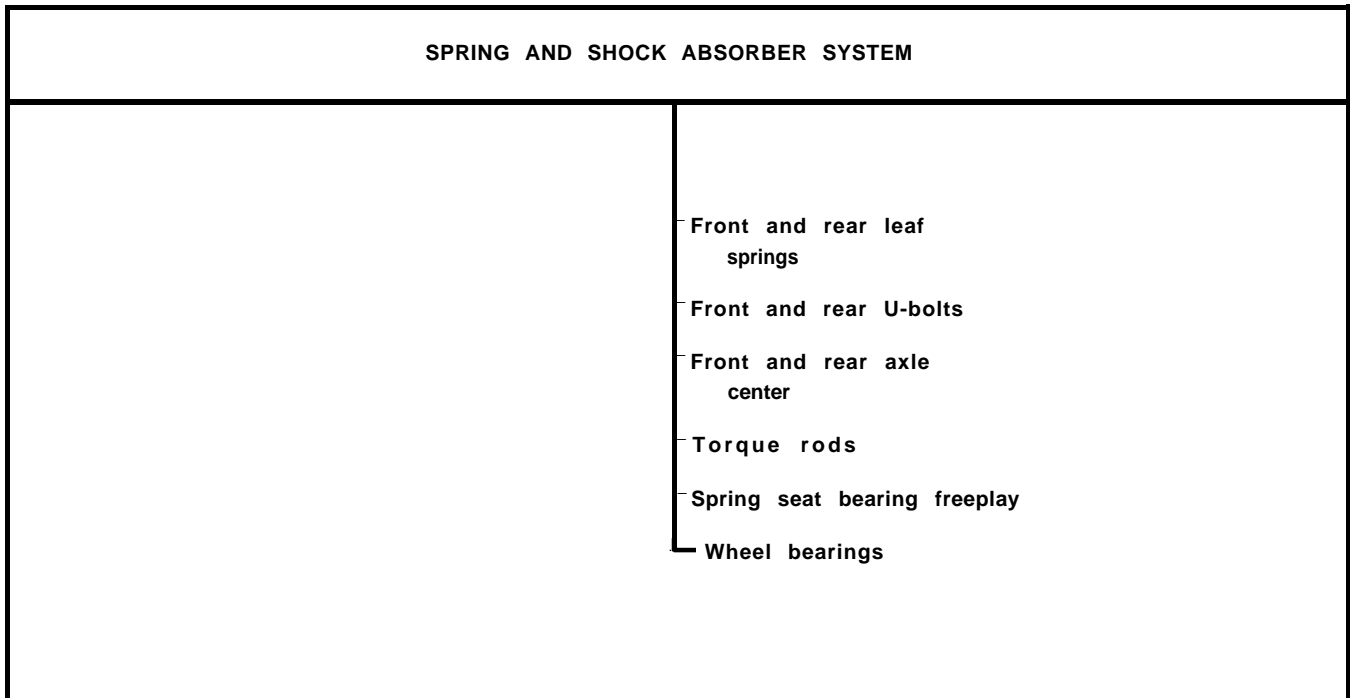

Figure 5-15. Troubleshooting Roadmap, Spring and Shock Absorber System

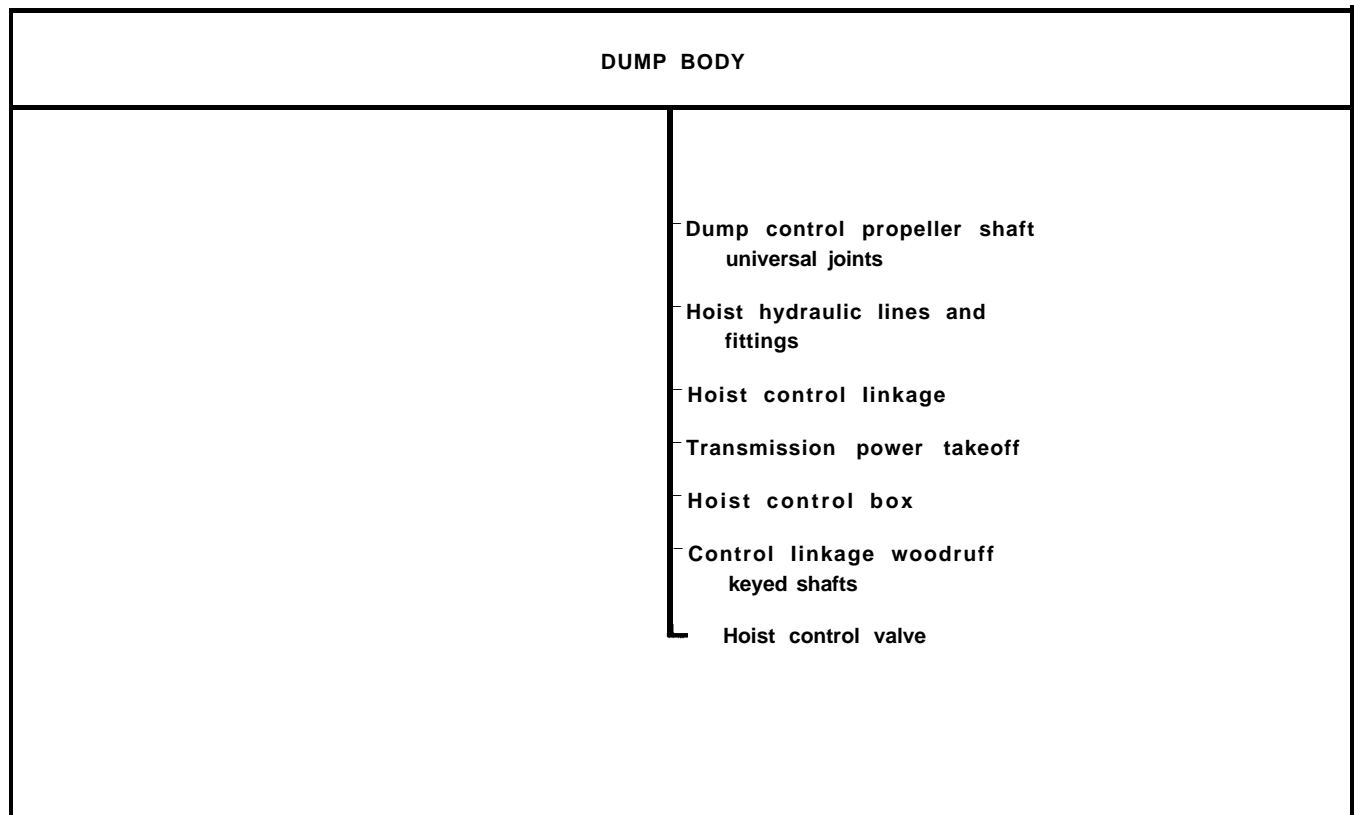

Figure 5-16. Troubleshooting Roadmap, Dump Body

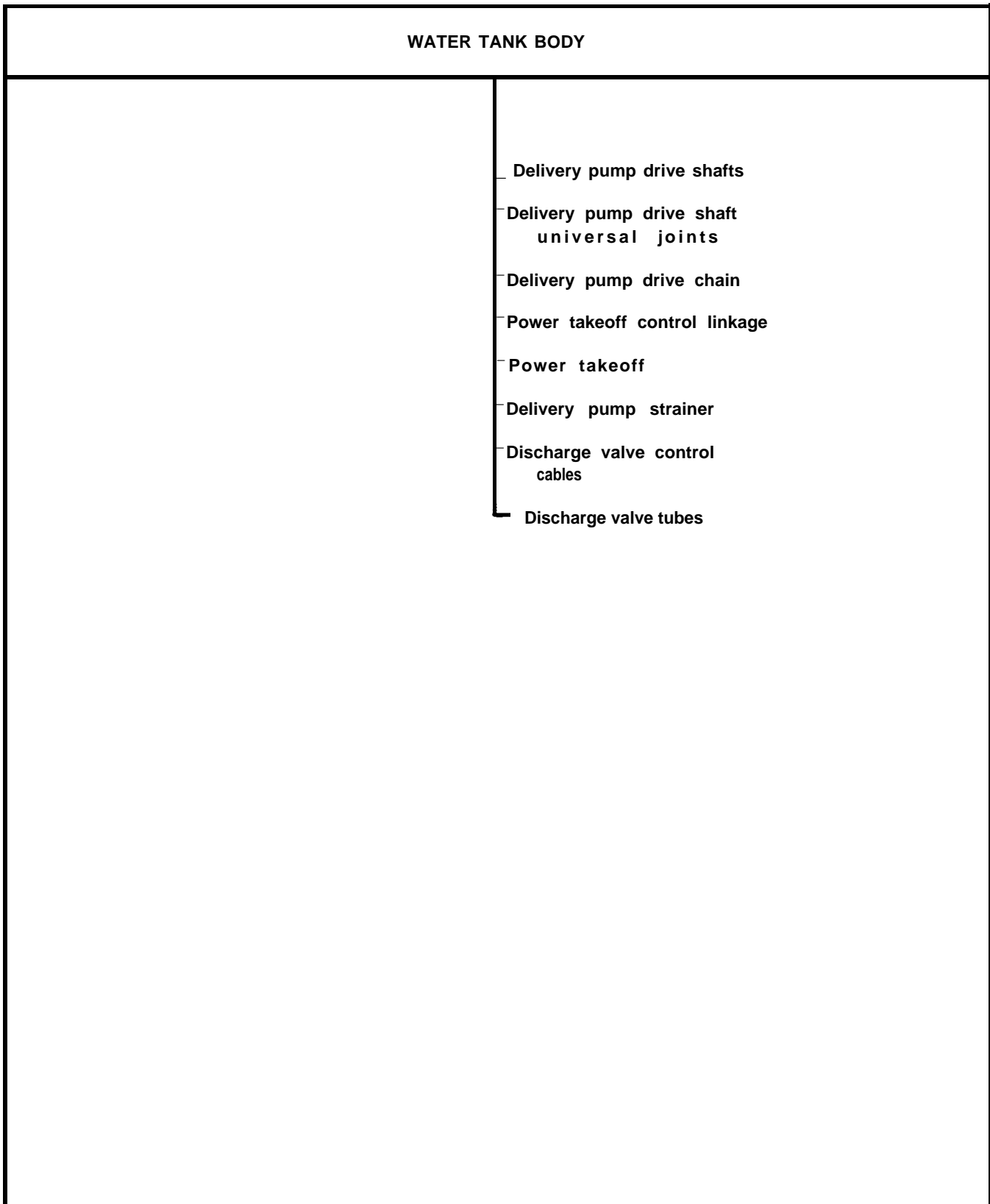

Figure 5-17. Troubleshooting Roadmap, Water Tank Body

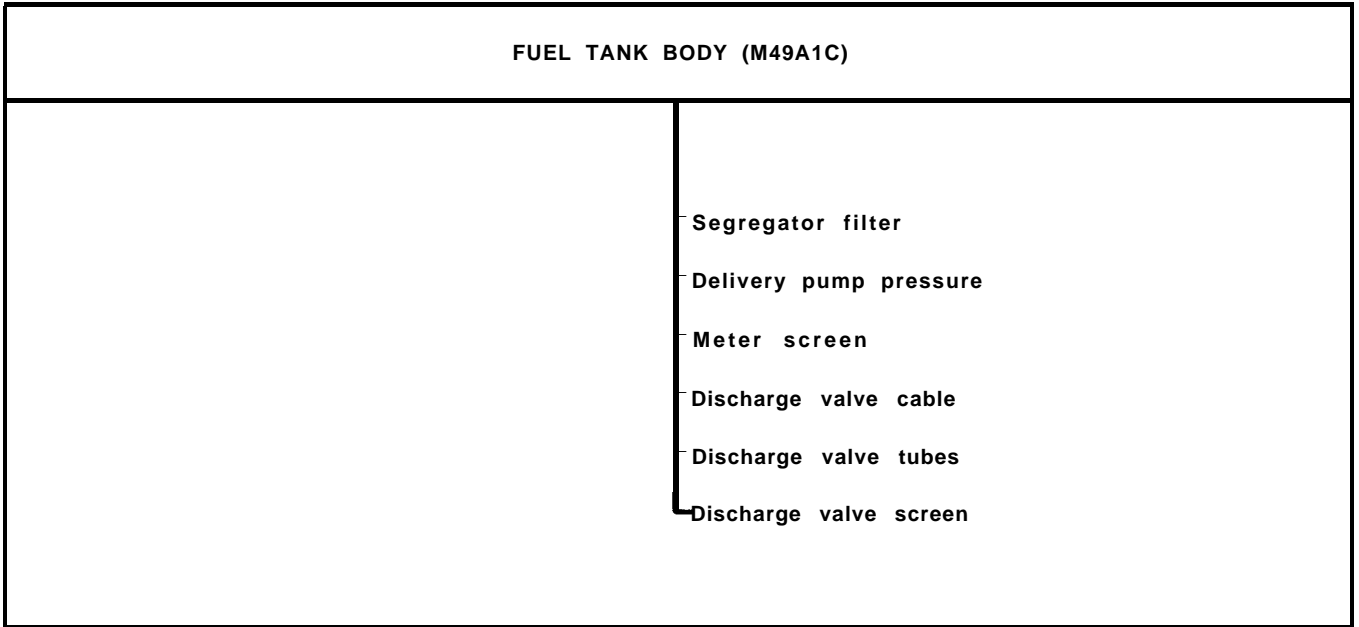

Figure 5-18. Troubleshooting Roadmap, Fuel Tank Body (M49A1C)

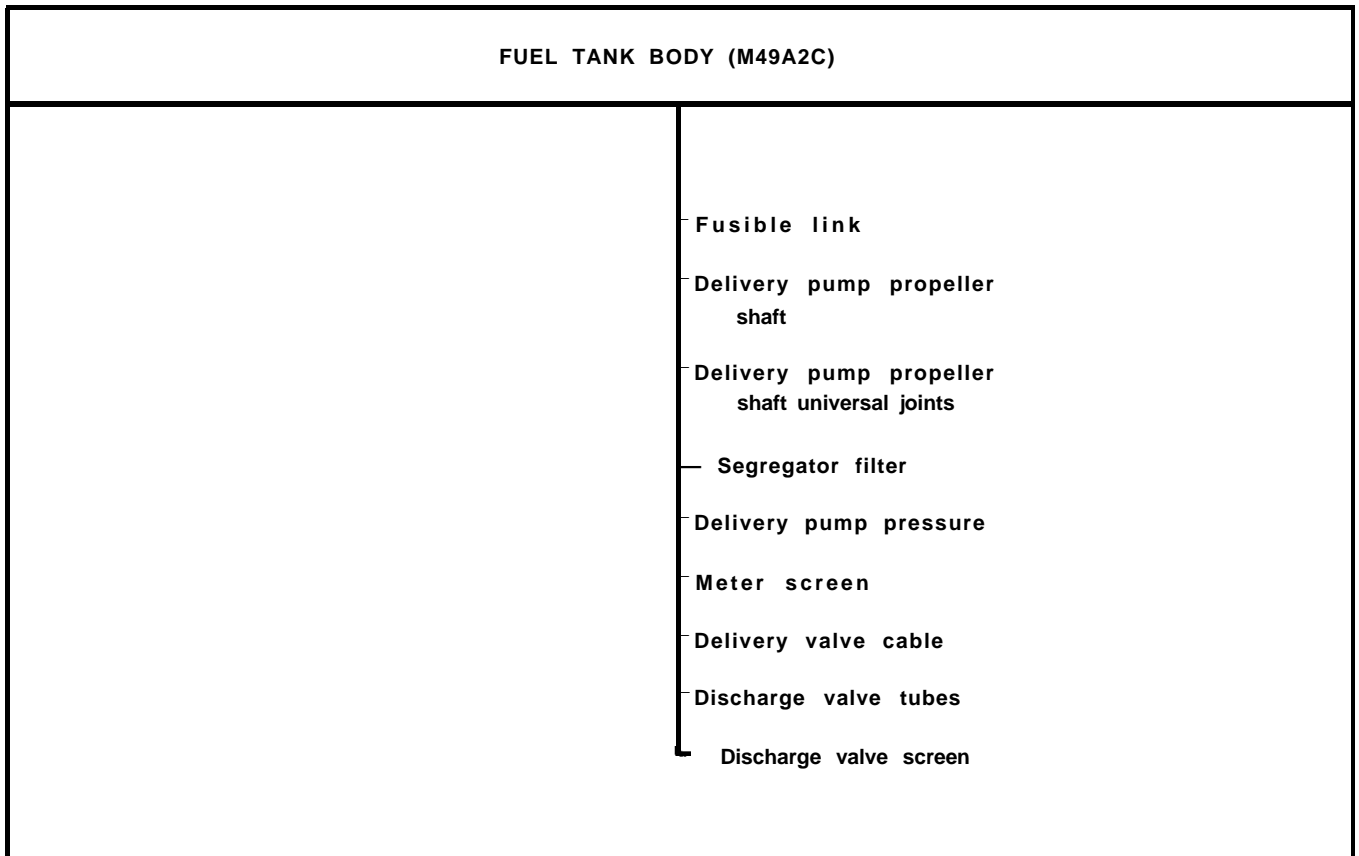

Figure 5-19. Troubleshooting Roadmap, Fuel Tank Body (M49A2C)

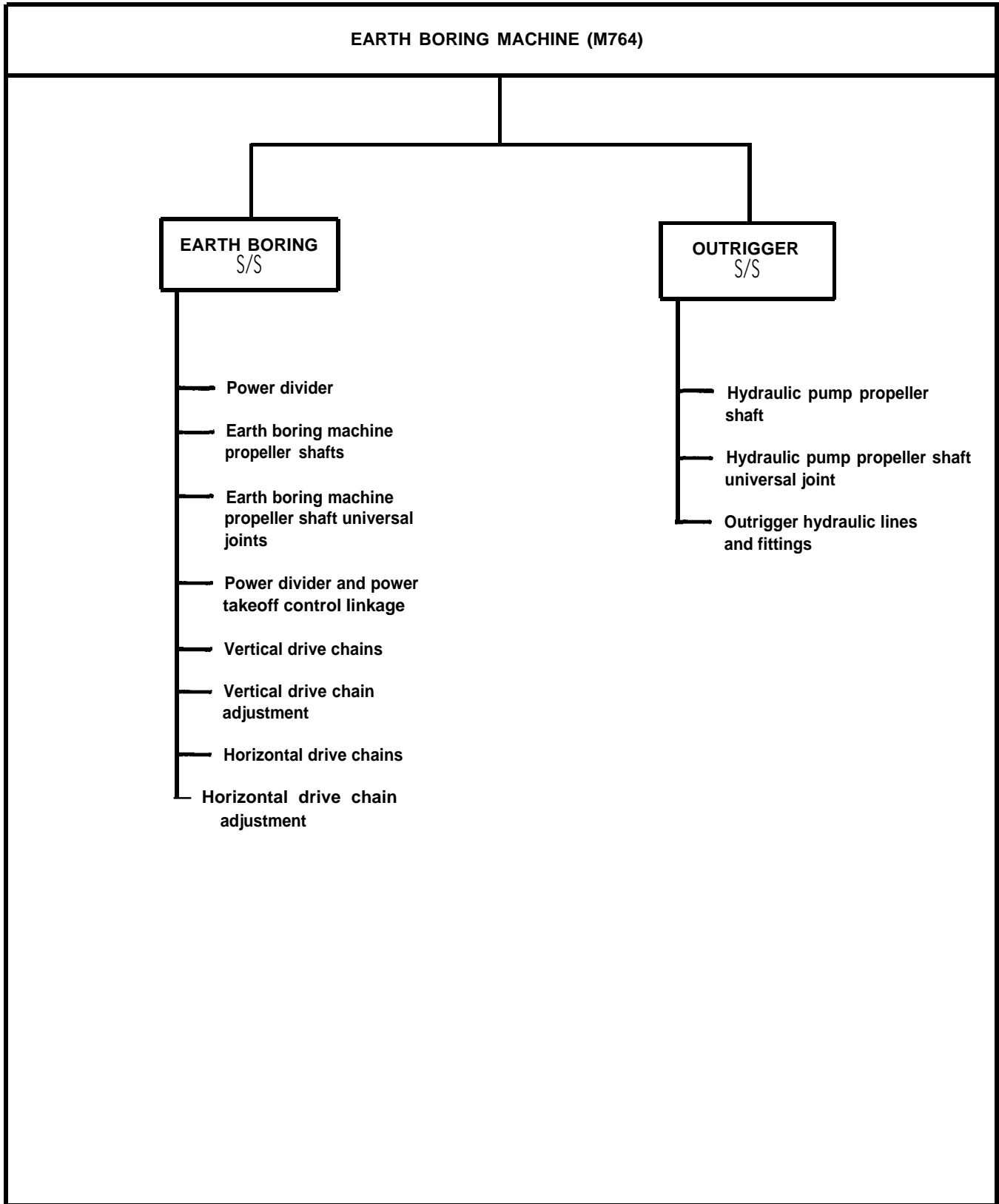

Figure 5-20. Troubleshooting Roadmap, Earth Boring Machine (M764)

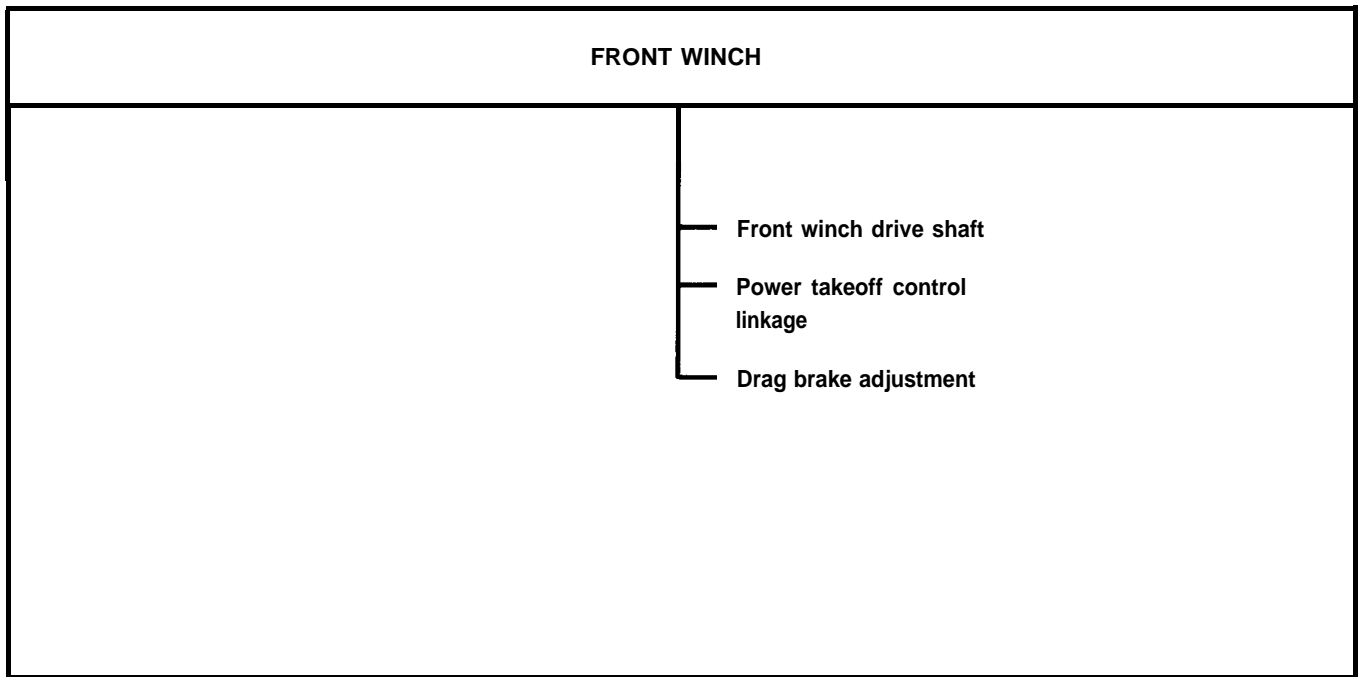

Figure 5-21. Troubleshooting Roadmap, Front Winch

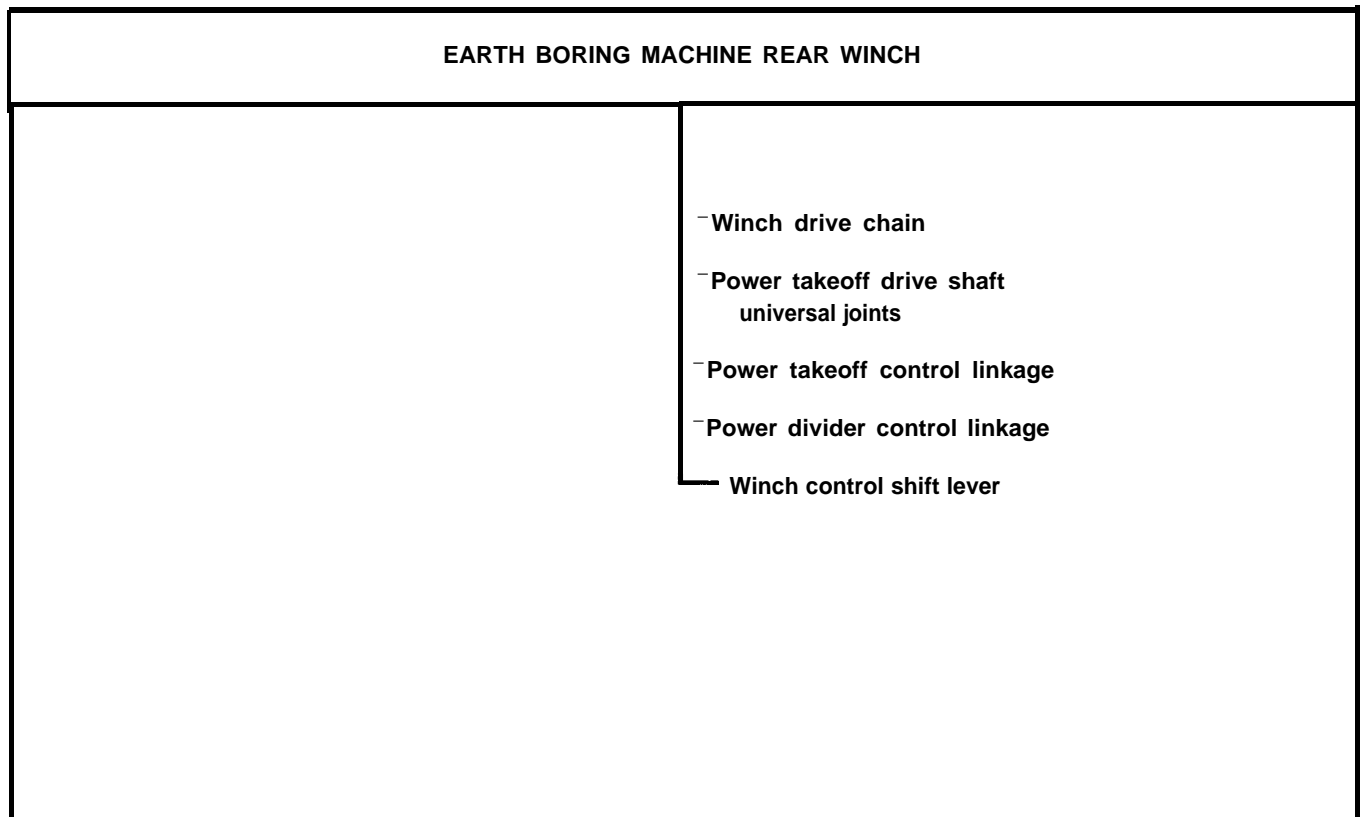

Figure 5-22. Troubleshooting Roadmap, Earth Boring Machine Rear Winch

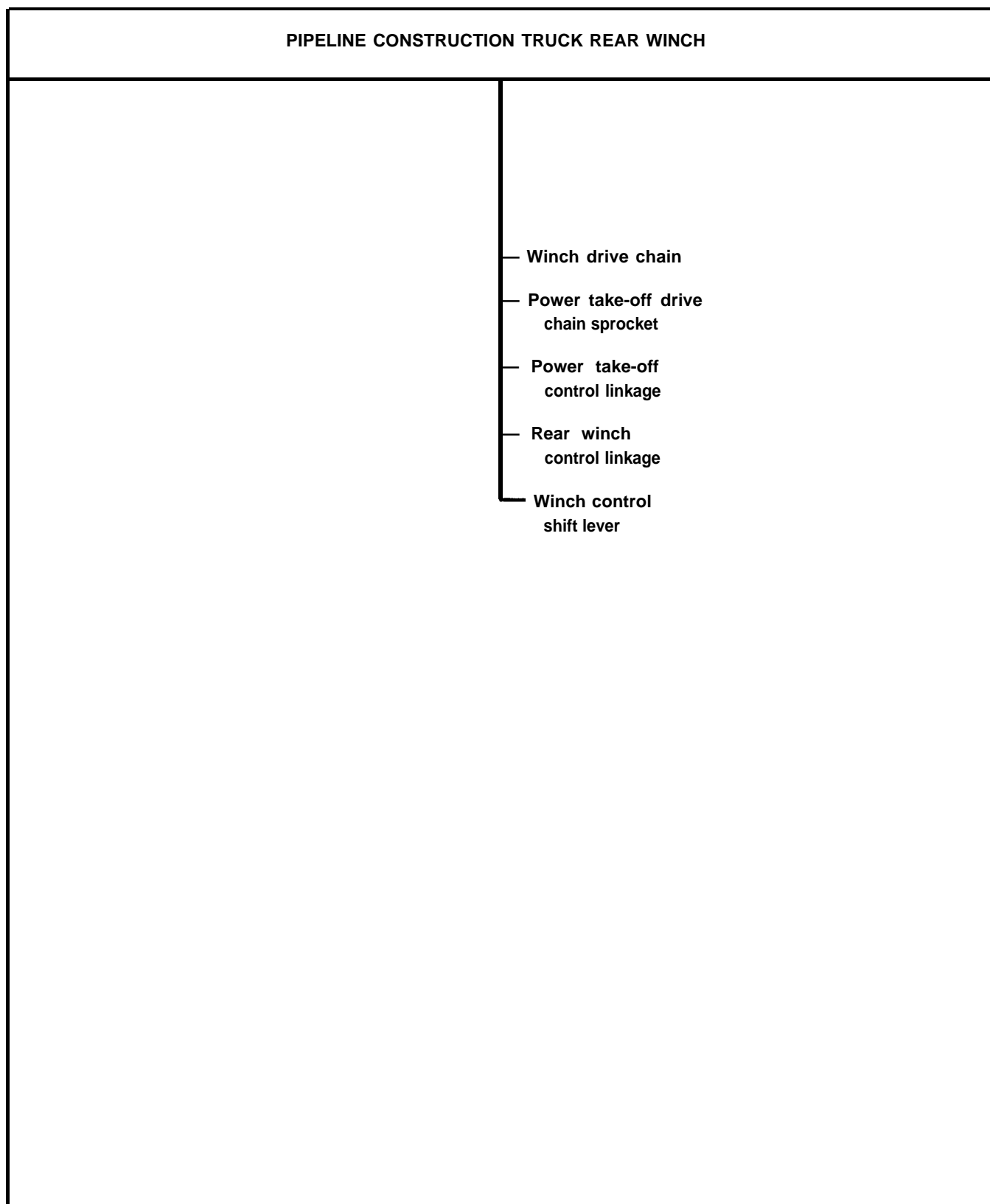

Figure 5-23. Troubleshooting Roadmap, Pipeline Construction Truck, Rear Winch

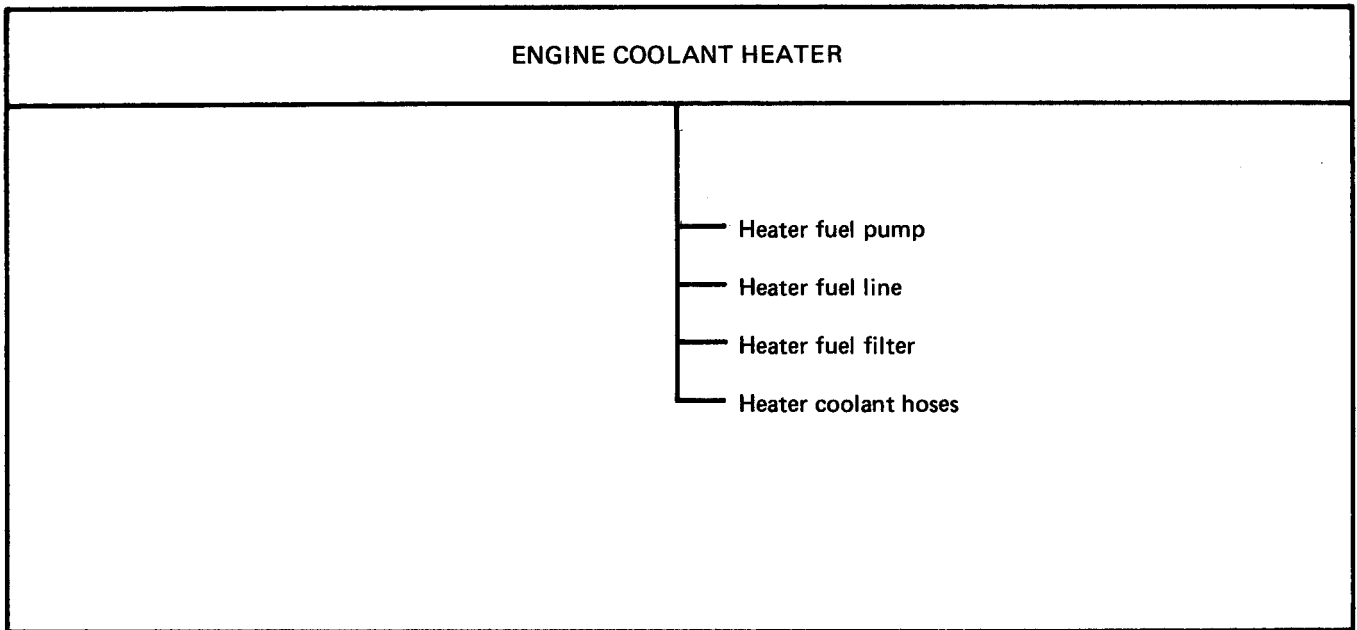

Figure 5-24. Troubleshooting Roadmap, Engine Coolant Heater

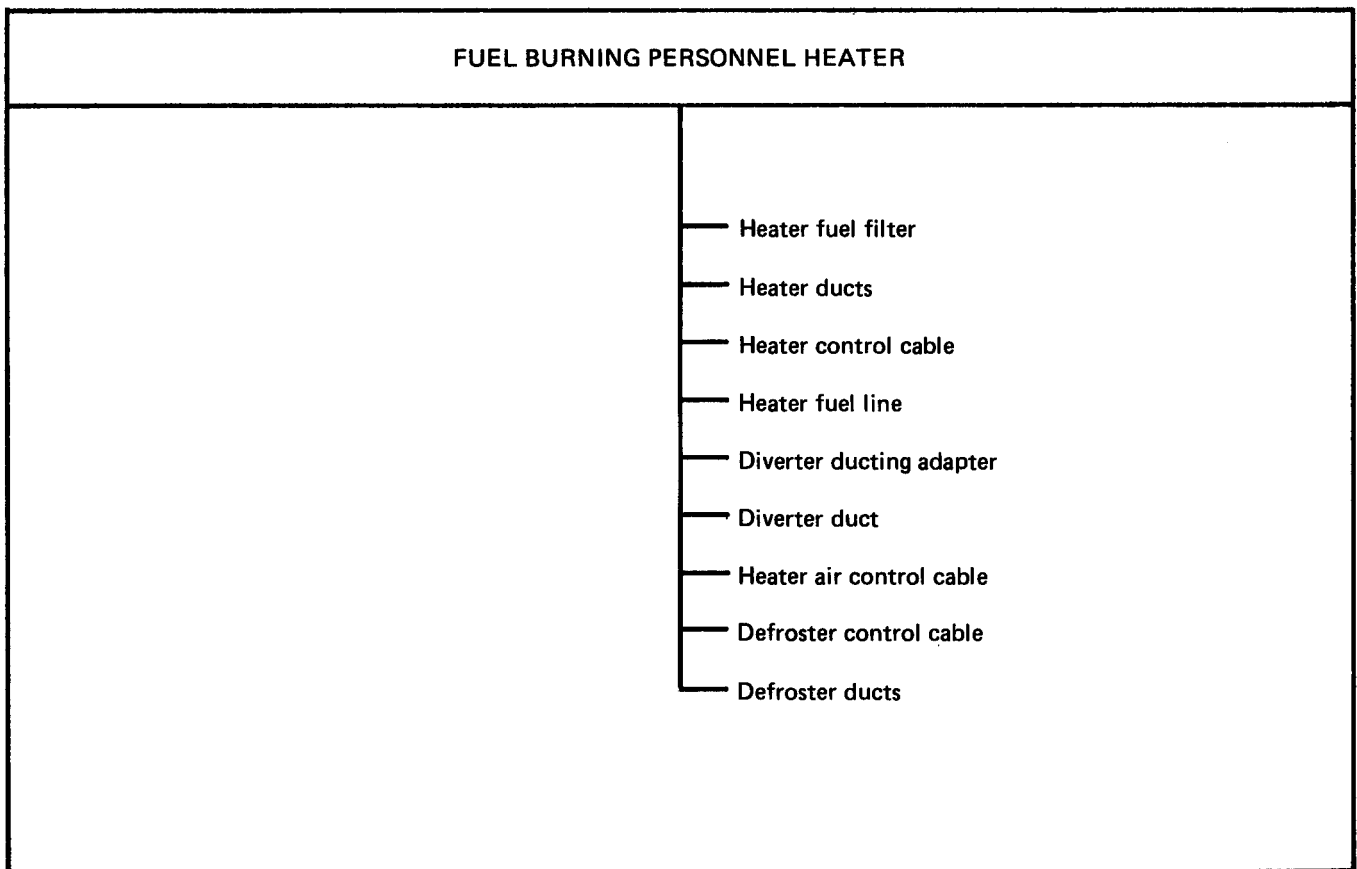

Figure 5-25. Troubleshooting Roadmap, Fuel Burning Personnel Heater

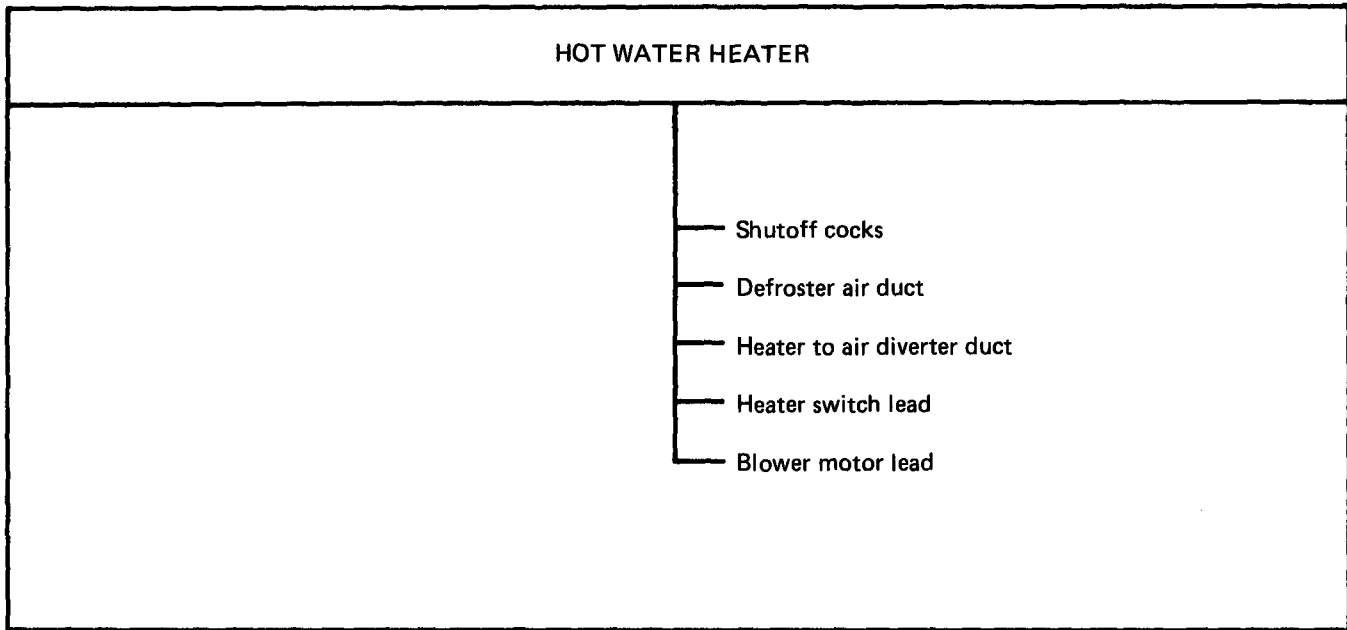

Figure 5-26. Troubleshooting Roadmap, Hot Water Heater

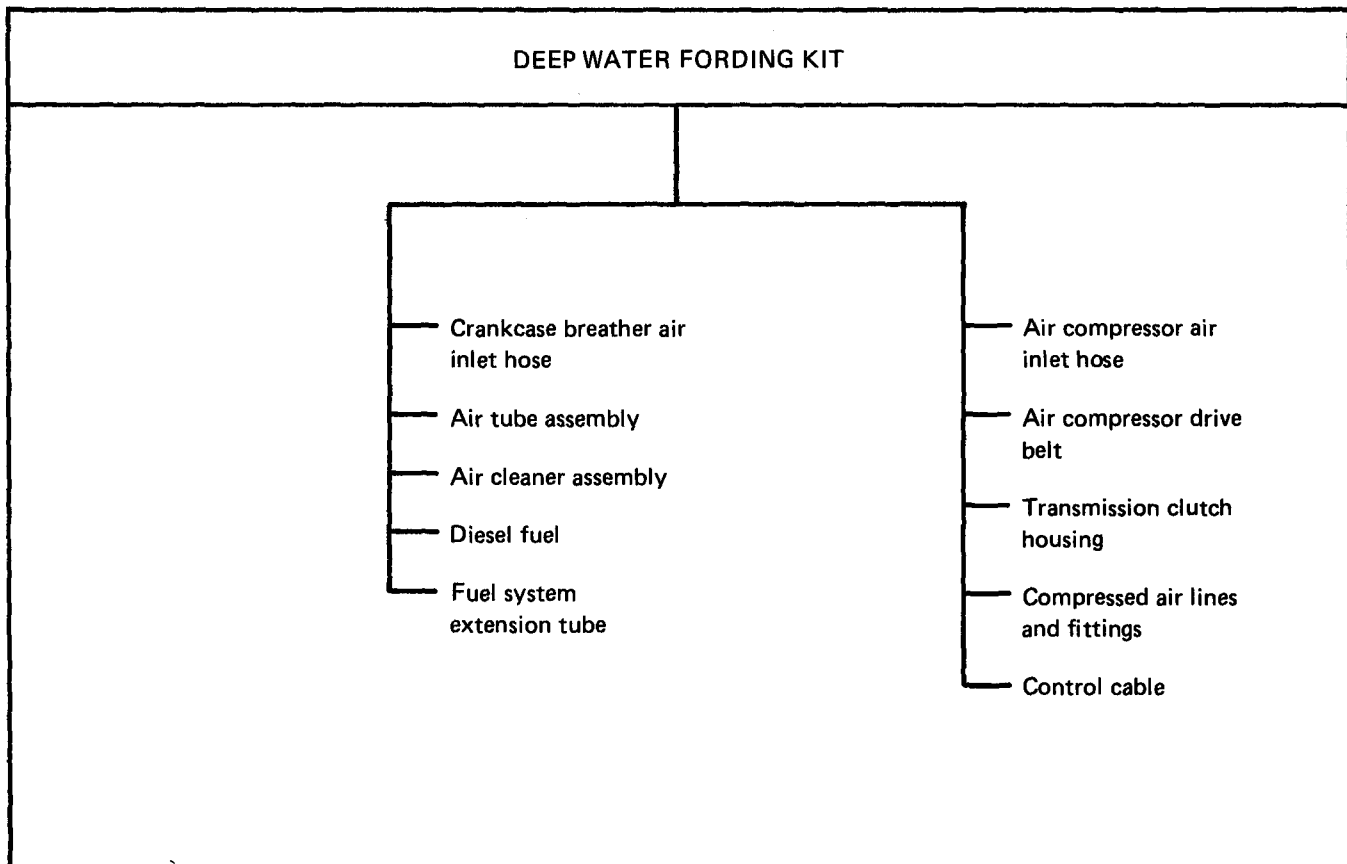

Figure 5-27. Troubleshooting Roadmap, Deep Water Fording Kit

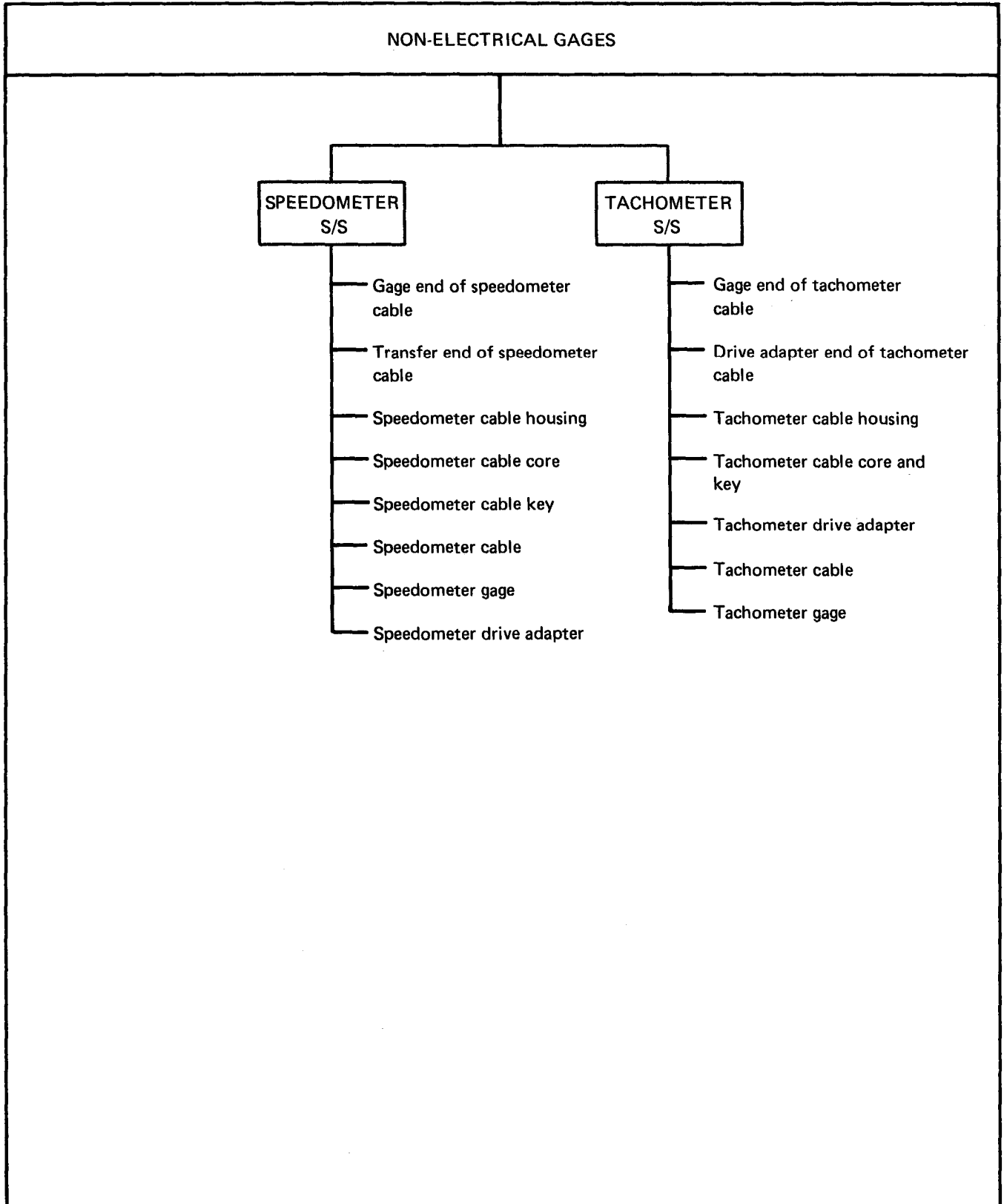

Figure 5-28. Troubleshooting Roadmap, Non-Electrical Gages

CHAPTER 6

FAULT SYMPTOM INDEXES

6-1. GENERAL. This chapter gives troubleshooting fault symptom indexes for every system of the truck for which you have detailed troubleshooting procedures. These indexes are in table form (tables 6-1 through 6-28) which gives you a quick way to check what material you have to use to do your troubleshooting.

6-2. INDEXES. Each index is divided into columns which give you information you need to help you do troubleshooting procedures. The following breakdown tells you what is in each column.

a. Subsystem Column. If the main system is divided into subsystems, the subsystems will be listed in this column.

b. Symptom Column. This column lists the symptoms, or problems for which detailed troubleshooting procedures are given.

c. Summary Column. This column tells you where to find the summary troubleshooting procedures for each symptom.

d. Detailed Column. This column tells you where to find the detailed troubleshooting procedure for each symptom.

e. Persons Column. This column tells you how many people are needed to do the troubleshooting procedure.

f. Special Tools Column. Any tools needed to do the troubleshooting procedure which are not included in your common tool kit are listed in this column.

g. Standard Tools Column. A dot in this column means that tools found in your common tool kit are needed to do the troubleshooting procedure.

h. Materials Column. This column tells you what materials are needed to do the troubleshooting procedure. These materials and how they will be issued will be decided by your maintenance officer.

i. Time Column. This column tells you how much time you will need to do the detailed troubleshooting procedure. The time will be decided by your maintenance officer.

TABLE 6-1. ENGINE SYSTEM								
SUBSYSTEM	SYMPTOM	TS PROCEDURE		RESOURCES REQ'D				
		SUMMARY	DETAILED	PERSONS	TEST EQUIPMENT		MATERIALS	TIME
					SPECIAL TOOLS	STANDARD TOOLS		
LUBRICATION	1. Low oil pressure	Figure 9-1	Figure 8-1	1				
	2. Engine uses more oil than normal	Figure 9-1	Figure 8-2	1				
DRIVELINE MOUNTING	3. Clunking noise heard during acceleration on all trucks except M36A2 and M342A2	Figure 9-2	Figure 10-1	1		•		
	4. Clunking noise heard during acceleration on trucks M36A2 and M342A2	Figure 9-2	Figure 10-2	1		•		

TABLE 6-2. CLUTCH SYSTEM								
SUBSYSTEM	SYMPTOM	TS PROCEDURE		RESOURCES REQ'D				
		SUMMARY	DETAILED	PERSONS	TEST EQUIPMENT		MATERIALS	TIME
					SPECIAL TOOLS	STANDARD TOOLS		
—	1. Truck creeps when clutch pedal is pressed	Figure 12-1	Figure 11-1	1		•		
	2. Clutch drags, slips, or does not engage	Figure 12-1	Figure 11-2	1		•		

TABLE 6-3. FUEL SYSTEM

SUBSYSTEM	SYMPTOM	TS PROCEDURE		RESOURCES REQ'D				
		SUMMARY	DETAILED	PERSONS	TEST EQUIPMENT			TIME
					SPECIAL TOOLS	STANDARD TOOLS	MATERIALS	
—	1. Engine cranks but does not start	Figure 14-1	Figure 13-1	1	—	•		
—	2. Engine lacks power	Figure 14-2	Figure 13-2	1	—	•		
—	3. Engine runs rough	Figure 14-2	Figure 13-3	1	—	•		
—	4. Poor fuel mileage	Figure 14-2	Figure 13-4	1	—			
—	5. Engine does not slow down when accelerator pedal is let go	Figure 14-3	Figure 13-5	1	—			
—	6. Engine runs after being shut off	Figure 14-3	Figure 13-6	1	—			
—	7. Engine stalls	Figure 14-2	Figure 13-7	1	—			
—	8. Hard starting	Figure 14-1	Figure 13-8		—			

TA 115236

TABLE 6-4. EXHAUST SYSTEM								
SUBSYSTEM	SYMPTOM	TS PROCEDURE		RESOURCES REQ'D				
		SUMMARY	DETAILED	PERSONS	TEST EQUIPMENT		MATERIALS	TIME
					SPECIAL TOOLS	STANDARD TOOLS		
—	1. Exhaust system makes noise from horizontal exhaust system with muffler	Figure 18-1,	Figure 17-1	1	—			
—	2. Exhaust fumes enter cab from horizontal exhaust system with muffler	Figure 18-1	Figure 17-2	1	—			
—	3. Exhaust system makes noise from horizontal exhaust system without muffler	Figure 18-2	Figure 17-3	1	—			
—	4. Exhaust fumes enter cab from horizontal exhaust system without muffler	Figure 18-2	Figure 17-4	1	—			
—	5. Exhaust system makes noise from vertical exhaust system with muffler	Figure 18-3	Figure 17-5	1	—			
—	6. Exhaust fumes enter cab from vertical exhaust system, with muffler	Figure 18-3	Figure 17-6	1	—			

FAULT SYMPTOM INDEX

TABLE 6-4. EXHAUST SYSTEM – CONT								
SUBSYSTEM	SYMPTOM	TS PROCEDURE		RESOURCES REQ'D				
		SUMMARY	DETAILED	PERSONS	TEST EQUIPMENT		MATERIALS	TIME
					SPECIAL TOOLS	STANDARD TOOLS		
—	7. Exhaust system makes noise from vertical exhaust system, without muffler	Figure 18-4	Figure 17-7	1	—			
—	8. Exhaust fumes enter cab from vertical exhaust system, without muffler	Figure 18-4	Figure 17-8	1	—			
—	9. Exhaust system makes noise on trucks M50A1, M50A2, and M50A3	Figure 18-5	Figure 17-9	1	—			

FAULT SYMPTOM INDEX

TABLE 6-5. COOLING SYSTEM								
SUBSYSTEM	SYMPTOM	TS PROCEDURE		RESOURCES REQ'D				
		SUMMARY	DETAILED	PERSONS	TEST EQUIPMENT		MATERIALS	TIME
					SPECIAL TOOLS	STANDARD TOOLS		
—	1. Engine temperature gage reads above 200°F while running	Figure 21-1	Figure 20-1	1	Fan hub puller pn 5120-708-3210	•		
—	2. Engine does not reach running temperature 165° to 200°F	Figure 21-1	Figure 20-2	1	—	•		
—	3. Noise coming from engine other than that of normal running	Figure 21-1	Figure 20-3	2	—	•		

TA 115239

FAULT SYMPTOM INDEX

TABLE 6-6. ELECTRICAL SYSTEM									
SUBSYSTEM	SYMPTOM	TS PROCEDURE		RESOURCES REQ'D					
		SUMMARY	DETAILED	PERSONS	TEST EQUIPMENT			MATERIALS	TIME
					MULTIMETER	HYDROMETER	STANDARD TOOLS		
STARTER	1. STARTER MOTOR will not crank engine	Figure 26-1	Figure 25-1	2	•		•		
CHARGING	2. Charging System (25 amp) GENERATOR has too high or low charging rate	Figure 26-2	Figure 25-2	1	•		•		
	3. Charging System (60 amp) ALTERNATOR has too high or low charging rate	Figure 26-2	Figure 25-3	1	•		•		
BATTERY	4. BATTERIES go dead when truck is parked over night or a period of days	Figure 26-3	Figure 25-4	1	•		•		

FAULT SYMPTOM INDEX

TABLE 6-6. ELECTRICAL SYSTEM – CONT									
SUBSYSTEM	SYMPTOM	TS PROCEDURE		RESOURCES REQ'D					
		SUMMARY	DETAILED	PERSONS	TEST EQUIPMENT			MATERIALS	TIME
					MULTIMETER	HYDROMETER	STANDARD TOOLS		
BATTERY	5. BATTERIES do not fully charge or do not hold a charge	Figure 26-3	Figure 25-5	1	•	•	•		
LIGHTING	6. One HEADLIGHT does not light, other headlight lights	Figure 26-4	Figure 25-6	1	•		•		
	7. Both HEADLIGHTS do not light. Other truck running lights light	Figure 26-4	Figure 25-7	1	•		•		
	8. BLACKOUT HEADLIGHT does not light, other truck running lights light	Figure 26-4	Figure 25-8	1	•		•		
	9. One or both FRONT BLACKOUT MARKER LAMPS do not light, other truck running lights light	Figure 26-5	Figure 25-9	1	•		•		

TA 115241

FAULT SYMPTOM INDEX

TABLE 6-6. ELECTRICAL SYSTEM – CONT									
SUBSYSTEM	SYMPTOM	TS PROCEDURE		RESOURCES REQ'D					
		SUMMARY	DETAILED	PERSONS	TEST EQUIPMENT			MATERIALS	TIME
					MULTIMETER	HYDROMETER	STANDARD TOOLS		
LIGHTING	10. One or both front PARKING LIGHTS do not light, other truck running lights light	Figure 26-5	Figure 25-10	1	•		•		
	11. One rear SERVICE STOPLIGHT does not light, other stoplight lights	Figure 26-6	Figure 25-11	2	•		•		
	12. Both SERVICE STOPLIGHTS do not light, other truck running lights light	Figure 26-6	Figure 25-12	2	•		•		
	13. One BLACKOUT STOPLIGHT does not light, other blackout stoplight lights	Figure 26-6	Figure 25-13	2	•		•		

TA 115242

FAULT SYMPTOM INDEX

TABLE 6-6. ELECTRICAL SYSTEM – CONT									
SUBSYSTEM	SYMPTOM	TS PROCEDURE		RESOURCES REQ'D					
		SUMMARY	DETAILED	PERSONS	TEST EQUIPMENT			MATERIALS	TIME
					MULTIMETER	HYDROMETER	STANDARD TOOLS		
LIGHTING	14. Both BLACKOUT STOPLIGHTS do not light, other truck running lights light	Figure 26-6	Figure 25-14	2	•		•		
	15. One or both SERVICE TAILLIGHT LIGHTS do not light, other truck running lights light	Figure 26-7	Figure 25-15	1	•		•		
	16. One or both rear BLACKOUT MARKER lights do not light, other truck running lights light	Figure 26-7	Figure 25-16	1	•		•		
	17. One lamp dim, flickering or lamps that work sometimes	Figure 26-8	Figure 25-17	1	•		•		

TA 115243

FAULT SYMPTOM INDEX

TABLE 6-6. ELECTRICAL SYSTEM – CONT									
SUBSYSTEM	SYMPTOM	TS PROCEDURE		RESOURCES REQ'D					
		SUMMARY	DETAILED	PERSONS	TEST EQUIPMENT			MATERIALS	TIME
					MULTIMETER	HYDROMETER	STANDARD TOOLS		
LIGHTING	18. All or many truck running lights dim, flicker, or work sometimes	Figure 26-8	Figure 25-18	1	•		•		
	19. Lamps burn out too often	Figure 26-8	Figure 25-19	1	•		•		
	20. All or many truck running lights do not light	Figure 26-8	Figure 25-20	1	•		•		
	21. One or more TRAILER SERVICE or BLACKOUT STOPLIGHTS do not light, all other truck lights light	Figure 26-9	Figure 25-21	2	•		•		

TA 115244

TABLE 6-6. ELECTRICAL SYSTEM – CONT									
SUBSYSTEM	SYMPTOM	TS PROCEDURE		RESOURCES REQ'D					
		SUMMARY	DETAILED	PERSONS	TEST EQUIPMENT			MATERIALS	TIME
					MULTIMETER	HYDROMETER	STANDARD TOOLS		
LIGHTING	22. One or more TRAILER LIGHTS do not light, (except SERVICE and BLACKOUT STOPLIGHTS). All other truck running lights light	Figure 26-9	Figure 25-22	2	•		•		
DIRECTIONAL	23. One CONTROL ASSEMBLY DIRECTIONAL SIGNAL LAMP does not light	Figure 26-10	Figure 25-23	1	•		•		
	24. None of the CONTROL ASSEMBLY DIRECTIONAL SIGNAL LAMPS light, other truck lights light	Figure 26-10	Figure 25-24	1	•		•		
	25. When EMERGENCY FLASHER or TURN SIGNAL LAMPS are selected, lamps do not flash or flash at slow and uneven rate	Figure 26-10	Figure 25-25	1	•		•		
	26. TURN SIGNALS do not light in one or more positions of control assembly directional signal lever, all other truck lights light	Figure 26-10	Figure 25-26	1	•				

FAULT SYMPTOM INDEX

TABLE 6-6. ELECTRICAL SYSTEM – CONT									
SUBSYSTEM	SYMPTOM	TS PROCEDURE		RESOURCES REQ'D					
		SUMMARY	DETAILED	PERSONS	TEST EQUIPMENT			MATERIALS	TIME
					MULTIMETER	HYDROMETER	STANDARD TOOLS		
DIRECTIONAL SIGNAL	27. CONTROL ASSEMBLY DIRECTIONAL SIGNAL LAMP does not flash, rest of directional signal system works	Figure 26-10	Figure 25-27	1	•				
INSTRUMENTS AND GAGES	28. FUEL LEVEL GAGE does not work. All other gages work	Figure 26-11	Figure 25-28	1	•		•		
	29. TEMPERATURE GAGE does not work. All other gages work	Figure 26-11	Figure 25-29	1	•		•		
	30. OIL PRESSURE GAGE does not work, all other gages work	Figure 26-11	Figure 25-30	1	•		•		
	31. BATTER-GENERATOR INDICATOR does not work, all other gages work	Figure 26-11	Figure 25-31	1	•		•		
	32. No gages work	Figure 26-11	Figure 25-32	1					
WARNING	33. HORN does not work	Figure 26-12	Figure 25-33	1	•		•		
	34. LOW AIR WARNING BUZZER does not work	Figure 26-12	Figure 25-34	1	•		•		

TA 115246

TABLE 6-6. ELECTRICAL SYSTEM – CONT									
SUBSYSTEM	SYMPTOM	TS PROCEDURE		RESOURCES REQ'D					
		SUMMARY	DETAILED	PERSONS	TEST EQUIPMENT			MATERIALS	TIME
					MULTIMETER	HYDROMETER	STANDARD TOOLS		
FUEL PUMP/ MANIFOLD HEATER	35. FUEL PUMP does not work	Figure 26-13	Figure 25-35	1	•		•		
	36. ENGINE MANIFOLD HEATER does not work	Figure 26-13	Figure 25-36	1	•		•		
VAN BODY 24 VOLT	37. NO 24-VOLT equipment works	Figure 26-14	Figure 25-37	1	•				
	38. 24 volt DOME LIGHTS do not work	Figure 26-14	Figure 25-38	1	•		•		
	39. HEATER FUEL PUMP does not work	Figure 26-14	Figure 25-39	1	•		•		

TA 115247.

FAULT SYMPTOM INDEX

TABLE 6-6. ELECTRICAL SYSTEM – CONT

SUBSYSTEM	SYMPTOM	TS PROCEDURE		RESOURCES REQ'D					
		SUMMARY	DETAILED	PERSONS	TEST EQUIPMENT			MATERIALS	TIME
					MULTIMETER	HYDROMETER	STANDARD TOOLS		
VAN BODY 115 VOLT	40. One DOME LIGHT does not work, other DOME LIGHTS work	Figure 26-15	Figure 25-40	1	•		•		
	41. All DOME LIGHTS do not work	Figure 26-15	Figure 25-41	1	•		•		
	42. No power at POWER OUTPUT RECEPTACLE	Figure 26-15	Figure 25-42	1	•		•		
	43. No power available when CIRCUIT BREAKER is turned on	Figure 26-15	Figure 25-43	1	•		•		

TA 115248

FAULT SYMPTOM INDEX

TABLE 6-6. ELECTRICAL SYSTEM - CONT									
SUBSYSTEM	SYMPTOM	TS PROCEDURE		RESOURCES REQ'D					
		SUMMARY	DETAILED	PERSONS	TEST EQUIPMENT			MATERIALS	TIME
					MULTIMETER	HYDROMETER	STANDARD TOOLS		
VAN BODY 115 VOLT	44. 115 volt AC VENTILATOR BLOWER does not work	Figure 26-15	Figure 25-44	1	•		•		
HOT WATER HEATER	45. HOT WATER PERSONNEL HEATER DEFROSTER operates in "HI" position only	Figure 26-16	Figure 25-45	1	•		•		
	46. HOT WATER PERSONNEL HEATER DEFROSTER operates in "LO" position only	Figure 26-16	Figure 25-46	1	•		•		
	47. HOT WATER HEATER BLOWER does not operate in either blower position	Figure 26-16	Figure 25-47	1	•		•		

TA 115249

FAULT SYMPTOM INDEX

TABLE 6-6. ELECTRICAL SYSTEM – CONT										
SUBSYSTEM	SYMPTOM	TS PROCEDURE		RESOURCES REQ'D						
		SUMMARY	DETAILED	PERSONS	TEST EQUIPMENT			MATERIALS	TIME	
					MULTIMETER	HYDROMETER	STANDARD TOOLS			
HOT WATER HEATER	48. HOT WATER PERSONNEL HEATER does not turn off when switch is in "OFF" position	Figure 26-16	Figure 25-48	1	•		•			
WINTER-IZATION KIT	49. Only one CONTROL BOX will operate the HEATER FUEL PUMP	Figure 26-17	Figure 25-49	1	•		•			
	50. Neither CONTROL BOX will operate the HEATER FUEL PUMP	Figure 26-17	Figure 25-50	1	•		•			

TA 115250

TABLE 6-7. TRANSMISSION SYSTEM								
SUBSYSTEM	SYMPTOM	TS PROCEDURE		RESOURCES REQ'D				
		SUMMARY	DETAILED		TEST EQUIPMENT			
—	1. Transmission leaks oil	Figure 32-1	Figure 31-1	1	—			
—	2. Transmission gears grind when shifting	Figure 32-1	Figure 31-2	1	—			

TABLE 6-8. TRANSFER SYSTEM								
SUBSYSTEM	SYMPTOM	TS PROCEDURE		RESOURCES REQ'D				
		SUMMARY	DETAILED		TEST EQUIPMENT			
—	1. Transfer leaks oil	Figure 34-1	Figure 33-1	1	—	•		
—	2. Transfer is hard to shift, or POPSout of gear	Figure 34-1	Figure 33-2	1	—	•		
—	3. Clunking noise heard during acceleration on trucks M36A2 and M342A2	Figure 34-1	Figure 33-3	1	—	•		
—	4. Clunking noise heard during acceleration on all trucks except M36A2 and M342A2	Figure 34-1	Figure 33-4	1	—	•		

FAULT SYMPTOM INDEX

TABLE 6-9. PROPELLER SHAFT SYSTEM								
SUBSYSTEM	SYMPTOM	TS PROCEDURE		RESOURCES REQ'D				
		SUMMARY	DETAILED	PERSONS	TEST EQUIPMENT		MATERIALS	TIME
					SPECIAL TOOLS	STANDARD TOOLS		
—	1. Clunking noise heard during acceleration on all trucks except M36A2 and M342A2	Figure 37-1	Figure 36-2	1	—	•		
—	2. Clunking noise heard during acceleration on trucks M36A2 and M342A2	Figure 37-1	Figure 36-1	1	—	•		

TA 115252

FAULT SYMPTOM INDEX

TABLE 6-10. FRONT AXLE SYSTEM							
SUBSYSTEM	SYMPTOM	TS PROCEDURE		RESOURCES REQ'D			
		SUMMARY	DETAILED	PERSONS	TEST EQUIPMENT		
					SPECIAL TOOLS	STANDARD TOOLS	MATERIALS
—	1. Front axle makes noise	Figure 40-1	Figure 39-1	1	—	•	
—	2. Shimmy	Figure 40-1	Figure 39-2	1	Toe-in gage	•	
—	3. Front tires do not wear evenly	Figure 40-1	Figure 39-3	1	Toe-in gage		

TABLE 6-11. REAR AXLE SYSTEM							
SUBSYSTEM	SYMPTOM	TS PROCEDURE		RESOURCES REQ'D			
		SUMMARY	DETAILED	PERSONS	TEST EQUIPMENT		
					SPECIAL TOOLS	STANDARD TOOLS	MATERIALS
—	1. Rear axle makes noise	—	Figure 42-1	1	Floor jack	•	

TA 115253

TABLE 6-12. BRAKE SYSTEM								
SUBSYSTEM	SYMPTOM	TS PROCEDURE		RESOURCES REQ'D				
		SUMMARY	DETAILED	PERSONS	TEST EQUIPMENT		MATERIALS	TIME
					SPECIAL TOOLS	STANDARD TOOLS		
SERVICE BRAKES	1. Brake pedal pressure is spongy	Figure 45-1	Figure 44-1	1	—	•		
	2. No braking action	Figure 45-1	Figure 44-2	1	—	•		
	3. Trailer brakes do not work when brake pedal is pressed or hand control is used	Figure 45-1	Figure 44-3	1	—	•		
	4. Brake pedal sinks close to floorboard, or weak braking action	Figure 45-1	Figure 44-4	1	—	•		
	5. One brake drags or truck pulls to one side	Figure 45-1	Figure 44-5	1	—	•		
	6. Brakes drag	Figure 45-1	Figure 44-6	1	—	•		
HANDBRAKE	7. Handbrake does not hold parked truck	Figure 45-2	Figure 47-1	1	—	•		
	B. Handbrake assembly drags after handbrake has been put down	Figure 45-2	Figure 47-2	1	—	•		
COMPRESSED AIR	9. Buzzer does not shut off and air pressure gage reads below 60 psi	Figure 45-3	Figure 48-1	1	—	•		
	10. Low, or no reading on air pressure gage, and warning buzzer shuts off	Figure 45-3	Figure 48-2	1	—	•		
	11. Reading on air pressure gage is above normal	Figure 45-3	Figure 48-3	1	—	•		

FAULT SYMPTOM INDEX

TABLE 6-13. WHEEL SYSTEM								
SUBSYSTEM	SYMPTOM	TS PROCEDURE		RESOURCES REQ'D				
		SUMMARY	DETAILED	PERSONS	TEST EQUIPMENT		MATERIALS	TIME
					SPECIAL TOOLS	STANDARD TOOLS		
—	1. Shimmy	—	Figure 51-1	1	—	•		
—	2. Front tires do not wear evenly	—	Figure 51-2	1	—	•		

TABLE 6-14. STEERING SYSTEM								
SUBSYSTEM	SYMPTOM	TS PROCEDURE		RESOURCES REQ'D				
		SUMMARY	DETAILED	PERSONS	TEST EQUIPMENT		MATERIALS	TIME
					SPECIAL TOOLS	STANDARD TOOLS		
—	1. Hard steering	Figure 53-1	Figure 52-1	1	—	•		
—	2. Shimmy	Figure 53-1	Figure 52-2	1	Toe-in gage	•		
—	3. Truck pulls to one side	Figure 53-1	Figure 52-3	1	Toe-in gage	•		
—	4. Front tires do not wear evenly	Figure 53-1	Figure 52-4	1	Toe-in gage			

FAULT SYMPTOM INDEX

TABLE 6-15. SPRINGS AND SHOCK ABSORBERS SYSTEM								
SUBSYSTEM	SYMPTOM	TS PROCEDURE		RESOURCES REQ'D				
		SUMMARY	DETAILED	PERSONS	TEST EQUIPMENT		MATERIALS	TIME
					SPECIAL TOOLS	STANDARD TOOLS		
—	1. Truck leans to one side	Figure 56-1	Figure 55-1	1	—			
—	2. Rear axle makes noise	Figure 56-1	Figure 55-2	1	Floor jack, wheel bearing nut wrench	•		

TABLE 6-16. DUMP BODY								
SUBSYSTEM	SYMPTOM	TS PROCEDURE		RESOURCES REQ'D				
		SUMMARY	DETAILED	PERSONS	TEST EQUIPMENT		MATERIALS	TIME
					SPECIAL TOOLS	STANDARD TOOLS		
—	1. Dump body does not rise	Figure 58-1	Figure 57-1	2	—	•		
—	2. Dump body rises slowly	Figure 58-1	Figure 57-2	2	—	•		
—	3. Dump body will not hold in raised position	Figure 58-1	Figure 57-3	1	—	•		
—	4. Dump body will not lower	Figure 58-1	Figure 57-4	1	—	•		
—	5. Dump body does not rise all the way	Figure 58-1	Figure 57-5	2	—			

TA 115256

TABLE 6-17. WATER TANK BODY								
SUBSYSTEM	SYMPTOM	TS PROCEDURE		RESOURCES REQ'D				
		SUMMARY	DETAILED		TEST EQUIPMENT			
—	1. Water cannot be pumped from both tanks	Figure 62-1	Figure 61-1	1	—	•		
—	2. Water cannot be pumped from tank selected	Figure 62-1	Figure 61-2	1	—			
—	3. Water pumps out of both tanks slower than normal	Figure 62-1	Figure 61-3	1	—	•		
—	4. Water does not drain using gravity procedures	Figure 62-1	Figure 61-4	1	—			
—	5. Water drains slowly using gravity procedural	Figure 62-1	Figure 61-5	1	—			
—	6. Water pumps from tank selected slower than normal	Figure 62-1	Figure 61-6	1	—			
—	7. Tanks cannot be suction filled	Figure 62-1	Figure 61-7	1	—	•		

FAULT SYMPTOM INDEX

TABLE 6-18. FUEL TANK BODY (M49A1C)								
SUBSYSTEM	SYMPTOM	TS PROCEDURE		RESOURCES REQ'D				
		SUMMARY	DETAILED	PERSONS	TEST EQUIPMENT		MATERIALS	TIME
					SPECIAL TOOLS	STANDARD TOOLS		
---	1. Fuel does not pump out of tanks	Figure 66-1	Figure 65-1	1	—	•		
---	2. Fuel pumps out slowly	Figure 66-1	Figure 65-2	1	—	•		
---	3. Fuel does not pump from tank selected	Figure 66-1	Figure 65-3	1	—			
---	4. Fuel pumps from tank selected slowly	Figure 66-1	Figure 65-4	1	—			
---	5. Fuel does not drain from selected tank using gravity procedures	Figure 66-1	Figure 65-5	1	—			
---	6. Fuel drains from tank selected slowly using gravity procedures	Figure 66-1	Figure 65-6	1	—			
---	7. Tanks cannot be filled by suction	Figure 66-1	Figure 65-7	1	—	•		

TA 115258

TABLE 6-19. FUEL TANK BODY (M49A2C)								
SUBSYSTEM	SYMPTOM	TS PROCEDURE		RESOURCES REQ'D				
		SUMMARY	DETAILED	PERSONS	TEST EQUIPMENT		MATERIALS	TIME
					SPECIAL TOOLS	STANDARD TOOLS		
—	1. Fuel does not pump out of tanks	Figure 70-1	Figure 69-1	1				
—	2. Fuel pumps out slowly	Figure 70-1	Figure 69-2	1	—			
—	3. Fuel does not pump from tank selected	Figure 70-1	Figure 69-3	1	—			
—	4. Fuel pumps from selected tank slowly	Figure 70-1	Figure 69-4	1	—			
—	5. Fuel does not drain from selected tank, using gravity procedures	Figure 70-1	Figure 69-5	1	—			
—	6. Fuel drains from selected tank slowly using gravity procedures	Figure 70-1	Figure 69-6	1	—			
—	7. Tanks cannot be filled by suction	Figure 70-1	Figure 69-7	1	—			

FAULT SYMPTOM INDEX

TABLE 6-20. EARTH BORING MACHINE M764								
SUBSYSTEM	SYMPTOM	TS PROCEDURE		RESOURCES REQ'D				
		SUMMARY	DETAILED	PERSONS	TEST EQUIPMENT		MATERIALS	TIME
					SPECIAL TOOLS	STANDARD TOOLS		
EARTH BORING MACHINE AND POLE SETTER	1. Earth boring machine does not work	Figure 74-1	Figure 73-1	1	—			
	2. Earth boring machine cannot be moved vertically	Figure 74-1	Figure 73-2	1	—	•		
	3. Earth boring machine cannot be moved horizontally	Figure 74-1	Figure 73-3	1	—	•		
OUTRIGGER"	1. Outriggers do not work	Figure 74-2	Figure 73-4	1	—			
	2. Outriggers work slowly	Figure 74-2	Figure 73-5	1	—			

FAULT SYMPTOM INDEX

TABLE 6-21. FRONT WINCH

SUBSYSTEM	SYMPTOM	TS PROCEDURE		RESOURCES REQ'D					
		SUMMARY	DETAILED	PERSONS	TEST EQUIPMENT			MATERIALS	TIME
					SPECIAL TOOLS	STANDARD TOOLS			
—	1 Winch does not pull load	Figure 78-1	Figure 77-1	1		•			
—	2 Winch does not hold load	Figure 78-1	Figure 77-2	1		•			
—	3 Winch drum spins too fast when unwinding cable	Figure 78-1	Figure 77-3	1		•			

TABLE 6-22. EARTH BORING MACHINE REAR WINCH

SUBSYSTEM	SYMPTOM	TS PROCEDURE		RESOURCES REQ'D					
		SUMMARY	DETAILED	PERSONS	TEST EQUIPMENT			MATERIALS	TIME
					SPECIAL TOOLS	STANDARD TOOLS			
—	1. Winch does not pull load	—	Figure 80-1	1	—				
—	2. Winch drum does not engage	—	Figure 80-2	1	—				

TA 115261

FAULT SYMPTOM INDEX

TABLE 6-23. PIPELINE CONSTRUCTION TRUCK REAR WINCH								
SUBSYSTEM	SYMPTOM	TS PROCEDURE		RESOURCES REQ'D				
		SUMMARY	DETAILED		TEST EQUIPMENT		MATERIALS	TIME
					SPECIAL TOOLS	STANDARD TOOLS		
---	1. Winch does not pull load	---	Figure 81-1	1	—	•		
---	2. Winch does not hold load	---	Figure 81-2	1	—			
---	3. Winch drum does not engage	---	Figure 81-3	1	—			

TABLE 6-24. ENGINE COOLANT HEATER								
SUBSYSTEM	SYMPTOM	TS PROCEDURES		RESOURCES REQ'D				
		SUMMARY	DETAILED		TEST EQUIPMENT		MATERIALS	TIME
					SPECIAL TOOLS	STANDARD TOOLS		
---	1. Heater does not start when switch is turned on	Figure 83-1	Figure 82-1	1	—	•		
---	2. Heater works for several minutes then stops	Figure 83-1	Figure 82-2	1	—			
---	3. Heater output is low	Figure 83-1	Figure 82-3	2	—	•		
---	4. Heater has no heat output	Figure 83-1	Figure 82-4	1	—	•		
---	5. Blower works, but there is no heat in system	Figure 83-1	Figure 82-5	2	—	•		

TA 115262

TABLE 6-25. FUEL BURNING PERSONNEL HEATER								
SUBSYSTEM	SYMPTOM	TS PROCEDURES		RESOURCES REQ'D				
		SUMMARY	DETAILED	PERSONS	TEST EQUIPMENT		MATERIALS	TIME
					SPECIAL TOOLS	STANDARD TOOLS		
—	1. Heater does not start	Figure 88-1	Figure 87-1	1	—			
—	2. Heater and defroster do not work	Figure 88-1	Figure 87-2	1	—			
—	3. Heater does not work	Figure 88-1	Figure 87-3	1	—			
—	4. Defroster does not work	Figure 88-1	Figure 87-4	1	—			
—	5. Heater and defroster does not give off enough heat	Figure 88-1	Figure 87-5	1	—			
—	6. Defroster does not give off enough heat	Figure 88-1	Figure 87-6	1	—			
—	7. Heater does not give off enough heat	Figure 88-1	Figure 87-7	1	—			

FAULT SYMPTOM INDEX

TABLE 6-26. HOT WATER HEATER								
SUBSYSTEM	SYMPTOM	TS PROCEDURES		RESOURCES REQ'D				
		SUMMARY	DETAILED		TEST EQUIPMENT			TIME
					SPECIAL TOOLS	STANDARD TOOLS	MATERIALS	
—	1. Cool or cold air at outlets after engine has reached operating temperature	Figure 92-1	Figure 91-1	1	—			
—	2. No air flow at heat outlet	Figure 92-1	Figure 91-2	1	—			
—	3. Blower motor does not work	Figure 92-1	Figure 91-3	1	—			
—	4. Blower motor operates on HI only	Figure 92-1	Figure 91-4	1	—			
—	5. No air flow at defroster	Figure 92-1	Figure 91-5	1	—			
—	6. Blower operates in LO only	Figure 92-1	Figure 91-6	1	—			
—	7. Heat output too low	Figure 92-1	Figure 91-7	1	—			

TA 115264

TABLE 6-27. DEEP WATER FORDING KIT								
SUBSYSTEM	SYMPTOM	TS PROCEDURES		RESOURCES REQ'D				
		SUMMARY	DETAILED		TEST EQUIPMENT		MATERIALS	TIME
					SPECIAL TOOLS	STANDARD TOOLS		
ALL TRUCKS EXCEPT M35A1 AND SOME M35A2	1. Engine stalls while fording or after leaving water	Figure 95-1	Figure 94-1	1	—	•		
	2. Engine runs rough after leaving water	Figure 95-1	Figure 94-2	1	—			
TRUCKS M35A1 AND SOME M35A2	1. Engine stalls while fording or after leaving water	Figure 95-1	Figure 94-3	1	—	•		
	2. Engine runs rough after leaving water	Figure 95-1	Figure 94-4	1	—			
	1. Fording control handle does not pull out or Pulls out stiffly	Figure 95-2	Figure 94-5	1	—			
CLUTCH	1. Clutch slips after leaving water on all trucks with kit	Figure 95-3	Figure 94-6	1	—	•		
BRAKE	1. Warning buzzer sounds, or air compressor makes noise, after leaving water on all trucks with kit	Figure 95-3	Figure 94-7	1	—	•		

FAULT SYMPTOM INDEX

TABLE 6-28. NON-ELECTRICAL GAGES								
SUBSYSTEM	SYMPTOM	TS PROCEDURES		RESOURCES REQ'D				
		SUMMARY	DETAILED		TEST EQUIPMENT			TIME
					SPECIAL TOOLS	STANDARD TOOLS	MATERIALS	
SPEEDOMETER	1. Speedometer does not work	Figure 99-1	Figure 98-1	2	Variable speed drill	•		
	2. Speedometer does not show correct speed	Figure 99-1	Figure 98-2	1	—	•		
	3. Speedometer fluctuates	Figure 99-1	Figure 98-3	2	Variable speed drill	•		
	4. Speedometer is noisy	Figure 99-1	Figure 98-4	2	Variable speed drill	•		
TACHOMETER	1. Tachometer does not work	Figure 99-2	Figure 98-5	1	—	•		
	2. Tachometer fluctuates	Figure 99-2	Figure 98-6	1	—	•		
	3. Tachometer does not show correct reading	Figure 99-2	Figure 98-7	2	Spare tachometer	•		
	4. Tachometer is noisy	Figure 99-2	Figure 98-8	1	—	•		

TA 115266

CHAPTER 7

SAMPLE TROUBLESHOOTING PROCEDURE

7-1. GENERAL. This chapter gives sample troubleshooting procedures. The purpose of the sample procedures is to help you see how detailed troubleshooting procedures test equipment procedures, and summary troubleshooting procedures are used to find faults in a system.

7-2. SAMPLE DETAILED PROCEDURE. The sample detailed procedure given is the fuel system troubleshooting procedure for the symptom, ENGINE CRANKS BUT DOES NOT START. This symptom is one you will have when you try to start your truck and certain parts on the truck are not working correctly. In each numbered box, instructions are given which tell you what to do, and how to do it. A large dot is placed next to the "what to do" instructions, and small dots next to the "how to do it" instructions

a. Box number ① gives general instructions on getting the truck ready before you start to troubleshoot.

b. Box number ② gives fault isolation test instructions. In this case you are told to check flame heater fuel lines, and then all fuel lines and fittings. To help you find the flame heater fuel lines that you must check, you are told to see figure 15-1, given in chapter 15. Figure 15-1 is a support diagram that gives you a detailed picture of the fuel lines. The right way to check fuel lines is given in figure 16-4, in chapter 16. The fuel lines and fittings checks tell you what you must look for to decide if there is a problem in the fuel lines. These support diagrams and tests, or checks, are often referred to in detailed troubleshooting procedures to help you find the problem and fix it. After you do the tests you read the question at the bottom of box number ②. If the fuel lines are leaking, the answer to the question is **NO**, so you go to the next box.

c. Box number ③ gives you a corrective action. In this case the fault is either loose fittings or bent, broken, or cracked fuel lines. The corrective action is what you do to fix the fault, which is to tighten the loose fittings, or replace the bad fuel lines. If the engine still doesn't start after you do this, it could mean that there are other faults in the fuel system besides loose fittings or cracked fuel lines. When this happens, go back to the beginning of the procedure and do each step again until you find the other faults.

d. Sometimes the corrective actions given for a fault will tell you what to do to fix the fault, but will not give you detailed instructions on how to fix it. Instead, you will be told to refer to another volume in this manual for these instructions. Box number ⑤ is an example of this. If the answer to the questions that all the fault isolation test instruction boxes ask is **YES**, it means that the symptom cannot be corrected at the organizational level of maintenance. When this happens you are given the instruction " Tell direct support maintenance. "

7-3. SAMPLE TEST EQUIPMENT PROCEDURE . The sample test equipment procedure given is the Simpson 160 multimeter dc voltage test. This procedure tells you how to use the multieter to do the voltage tests you will need when you do electrical system troubleshooting.

a. The first box gives you the name of the test equipment procedure. It also tells you the kind of troubleshooting for which this procedure is used. In this case, the test equipment procedure is the DC VOLTAGE TEST. This test will be used to troubleshoot faults in the battery system, the charging system, and voltage drops in the electrical system.

b. Box (1) gives you detailed test instructions. Next to the large dot are instructions telling you what to do. In this example you are told to set up the multi-meter test leads. Next to the small dots are instructions telling you how to set up the test leads.

c. The multimeter jack table tells you which jack to plug the red (+) test lead into.

d. The multimeter function table tells you how to set the function/range switch.

7-4. SAMPLE SUMMARY TROUBLESHOOTING PROCEDURE. The sample summary troubleshooting procedure given is the electrical system summary for the problem "CHARGING SYSTEM CHARGING TOO HIGH OR LOW. "

a. The first box tells you what kinds of problems the summary covers. In this example, the summary covers charging system problems.

b. The charging system problems you will see on the truck are the fault symptoms "CHARGING SYSTEM (25 AMP) GENERATOR HAS TOO HIGH OR LOW CHARGING RATE" , and "CHARGING SYSTEM (60 AMP) ALTERNATOR HAS TOO HIGH OR LOW CHARGING RATE . "

c. To do the summary procedure for each fault symptom given, you follow the GO chains to each box. Any notes, cautions, or warnings that are given in the detailed troubleshooting procedures are also given in the summary.

d. General instructions telling you what to do are given in box (A) . Detailed instructions on how to do checks or tests are not given in the summary. If the answer to the question at the bottom of box A is (NO) , then you do the corrective action given in box (B) . If the answer is YES , follow the GO chains to box (C) and box (D) and check the parts of the truck given in those boxes. You then repair or replace the parts that are bad.

e. The note given under the last box in the GO chain means that you should look at the electrical system fault symptom index. This index will tell you where you can find the detailed troubleshooting procedure for the symptom "CHARGING SYSTEM (25 AMP) GENERATOR HAS TOO HIGH OR LOW CHARGING RATE. "

FUEL SYSTEM TROUBLESHOOTING

Symptom

1 ENGINE CRANKS BUT DOES NOT START

WARNING
 Diesel fuel is very flammable. Care must be used when choosing a place to work on fuel system. Keep truck about 50 feet away from an area where open flame, sparks, or smoking may cause a fire. Keep a fire extinguisher close by

1

- Make truck ready for work on fuel system
 - Find a well ventilated area
 - Park truck. Refer to TM 9-2320-209-10

GENERAL INSTRUCTIONS

2

- Check flame heater fuel lines
 - Look for a crushed or broken line. See figure 15-1.
 - Look for signs of fuel leaking from lines or fittings
 - Feel for loose fittings
 - Check all fuel lines and fittings
 - Fuel line and fitting checks are given in figure 16-4
- Are flame heater and engine fuel lines and fittings OK?

FAULT ISOLATION TEST INSTRUCTIONS

GO

Figure 7-1 (Sheet 1 of 6)

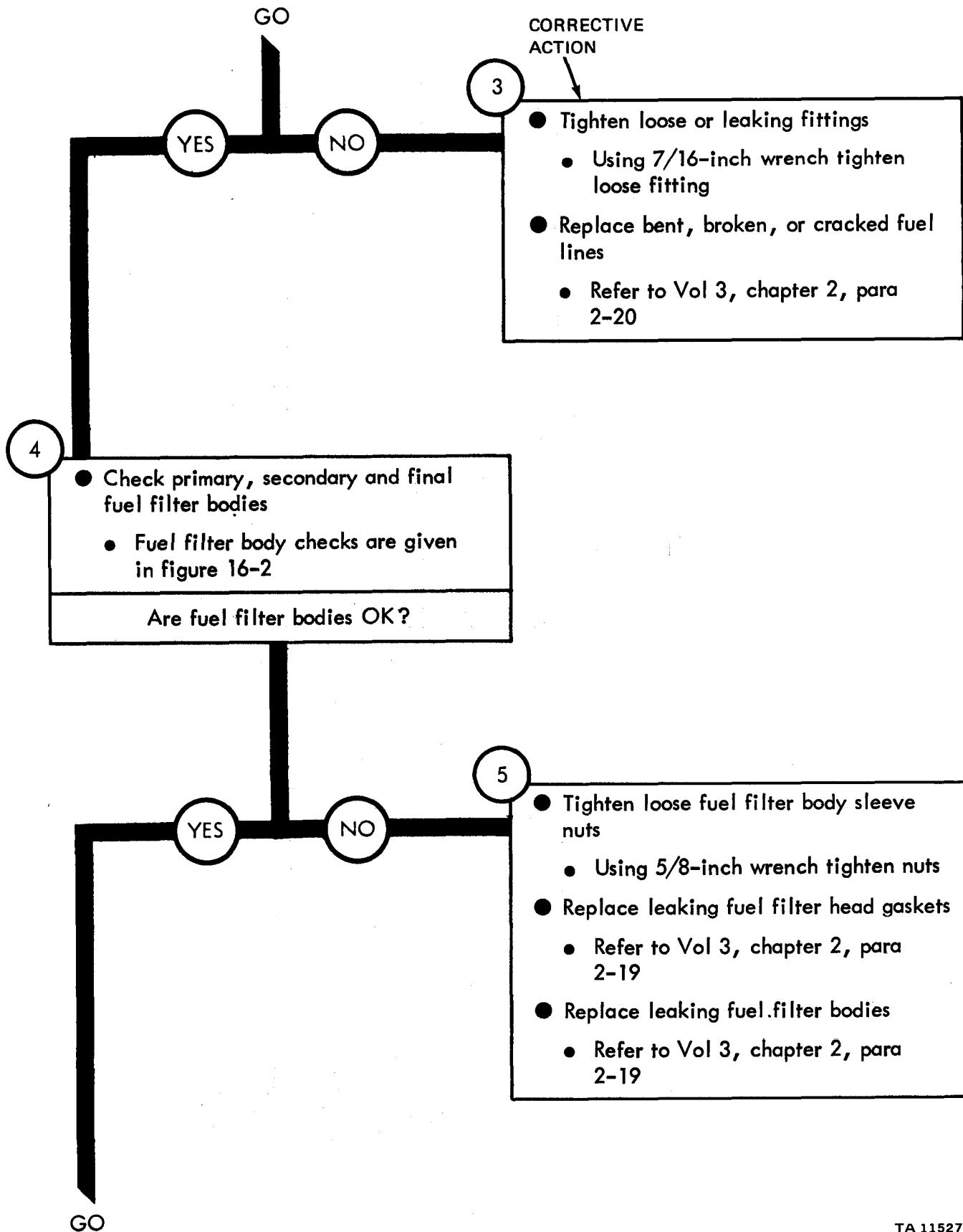

TA 115270

Figure 7-2 (Sheet 2 of 6)

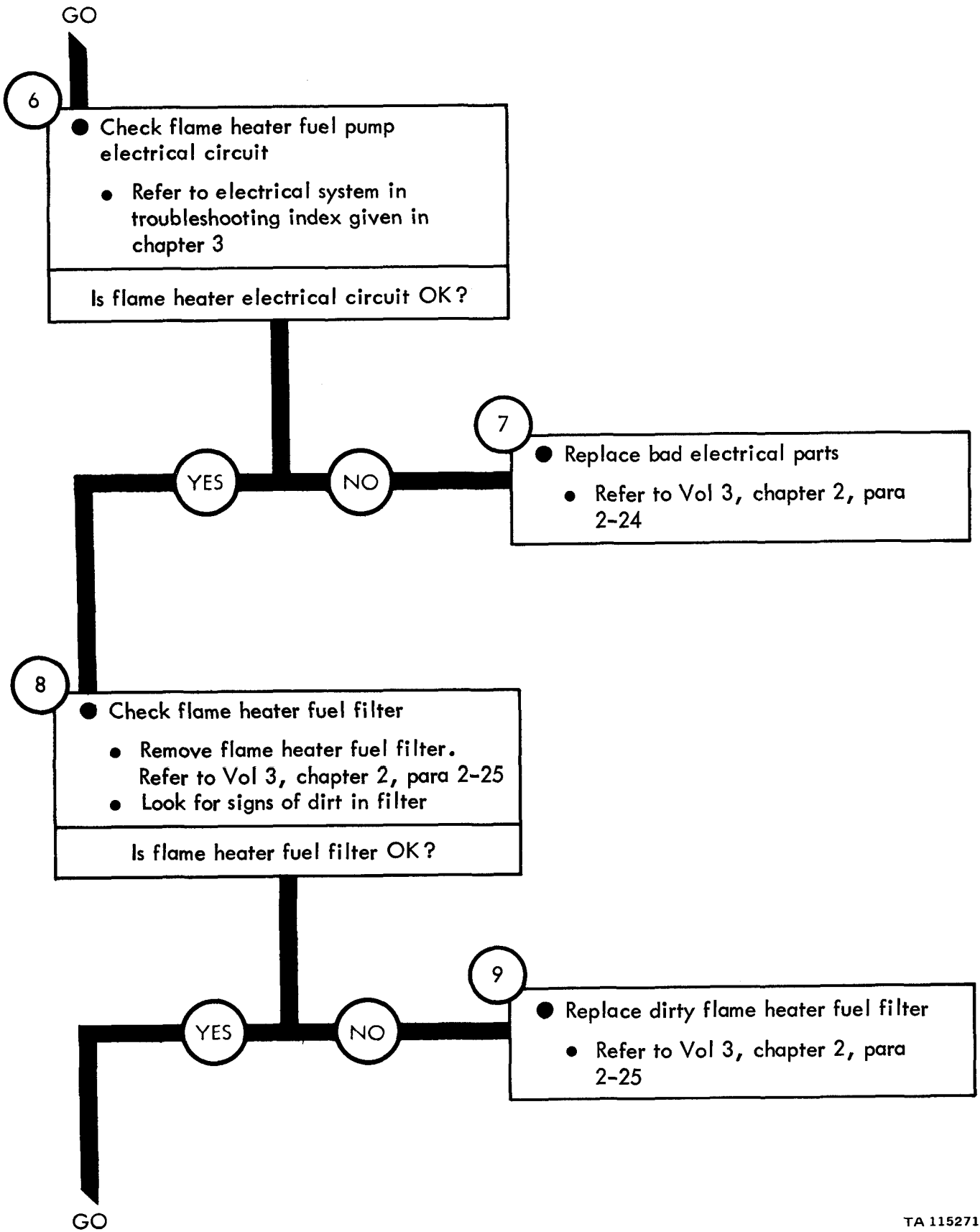

Figure 7-3 (Sheet 3 of 6)

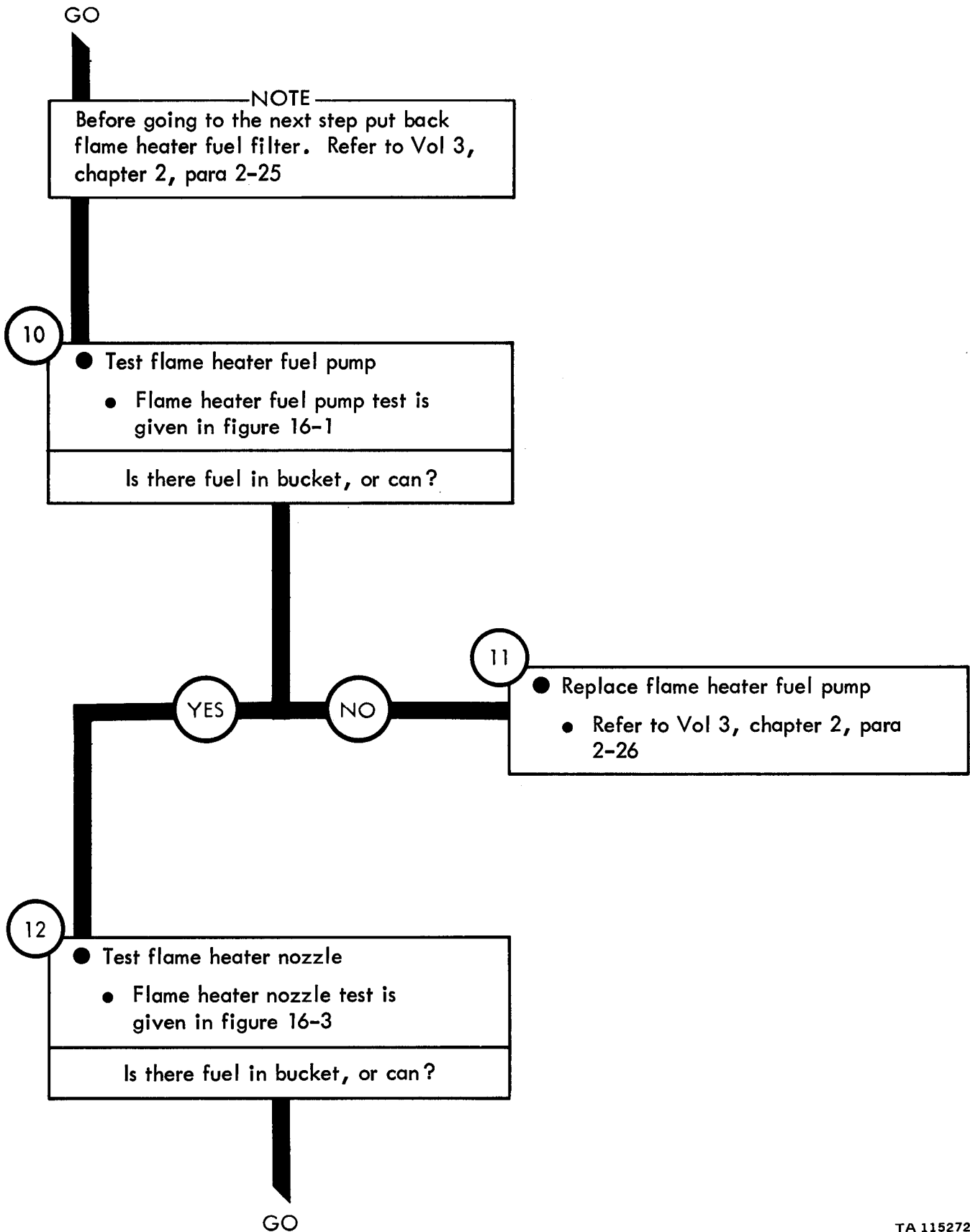

Figure 7-1 (Sheet 4 of 6)

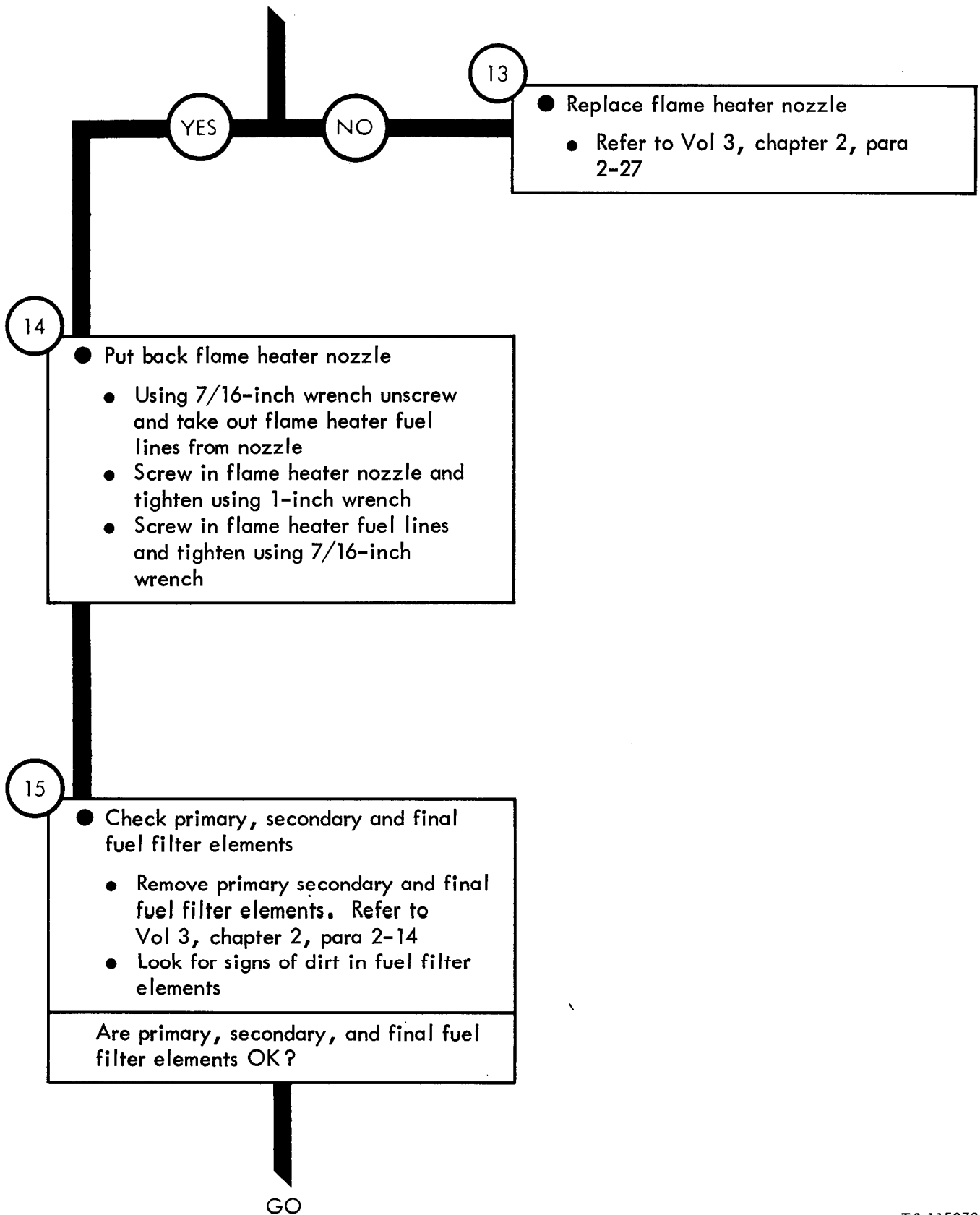

Figure 7-1 (Sheet 5 of 6)

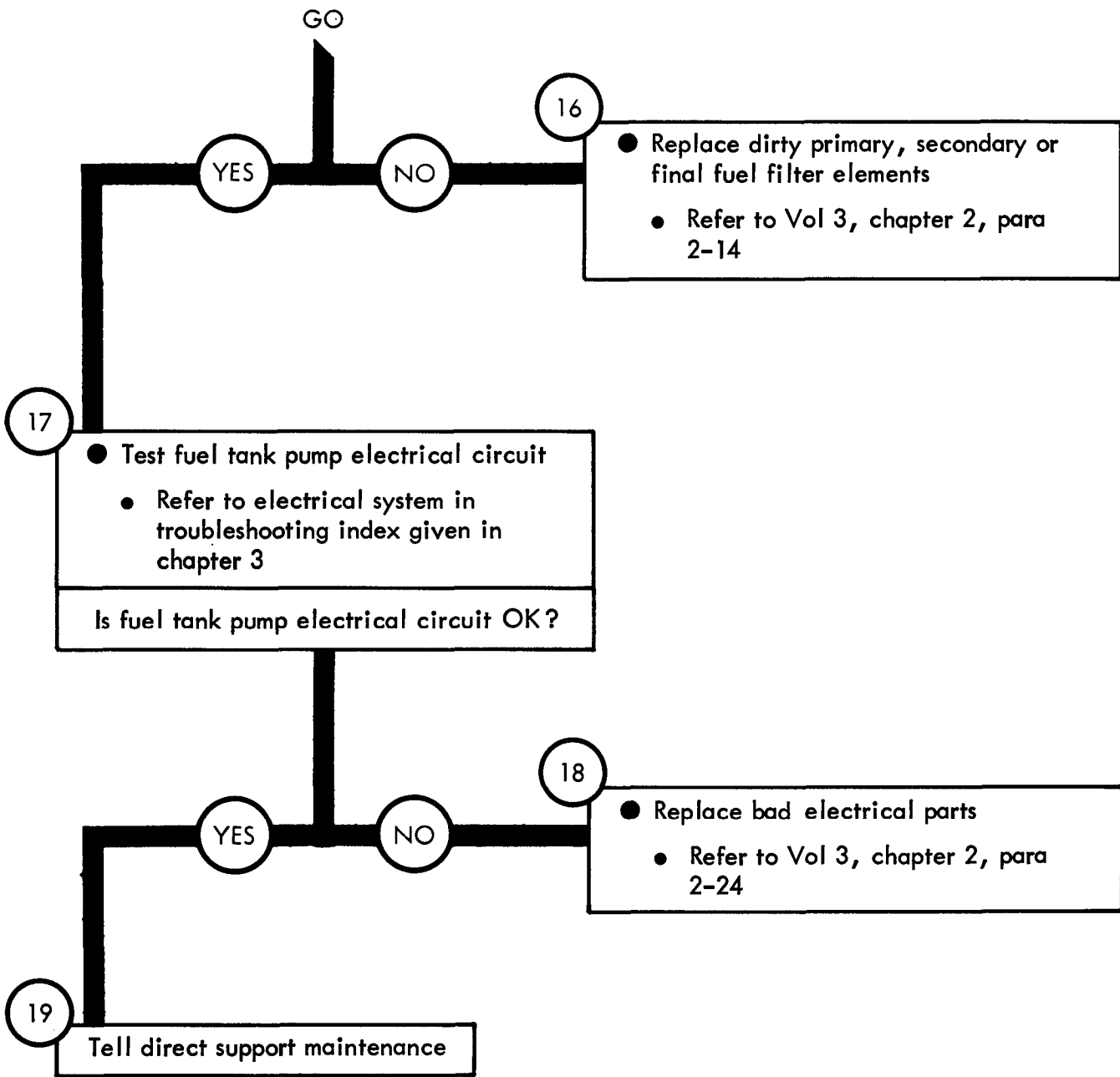

Figure 7-1 (Sheet 6 of 6)

Test

1 DC VOLTAGE TEST - To measure battery voltage, charging system output, and voltage drops at various test points

TEST EQUIPMENT PROCEDURE

DETAILED TEST INSTRUCTIONS

- 1
- Set up multimeter test leads:
 - Put jack plug of black (-) test lead into COM - jack.

Note: The highest truck DC voltage that is measured is about 28 volts. Therefore, the multimeter red (+) lead is never put into the 1000 VDC jack.

 - See table to find out which jack to put red (+) lead into. Table shows which jack to use when normal value of measured voltage is known or unknown.

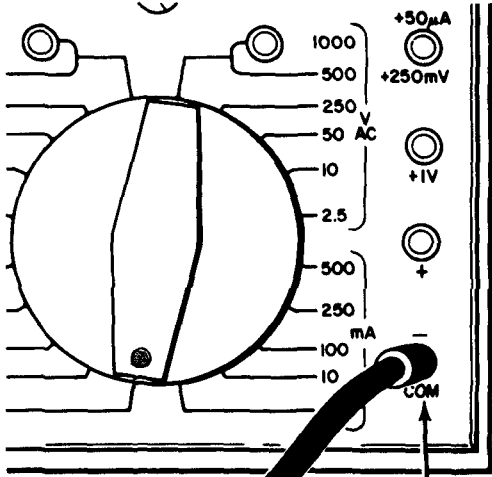

BLACK LEAD

THIS JACK IS THE METER CIRCUIT'S COMMON GROUND

IF NORMAL VALUE OF VOLTAGE BEING MEASURED IS THIS:	PUT RED LEAD INTO THIS JACK ON RIGHT SIDE OF MULTIMETER:
0 TO 230 MILLIVOLTS	+50 µA +250mV
230 MILLIVOLTS TO 0.8 VOLTS	+1V
0.8 TO 2 VOLTS	+
2 TO 8 VOLTS	+
8 TO 40 VOLTS	+
UNKNOWN	+

MULTIMETER JACK TABLE

GO

Figure 7-2 (Sheet 1 of 2)

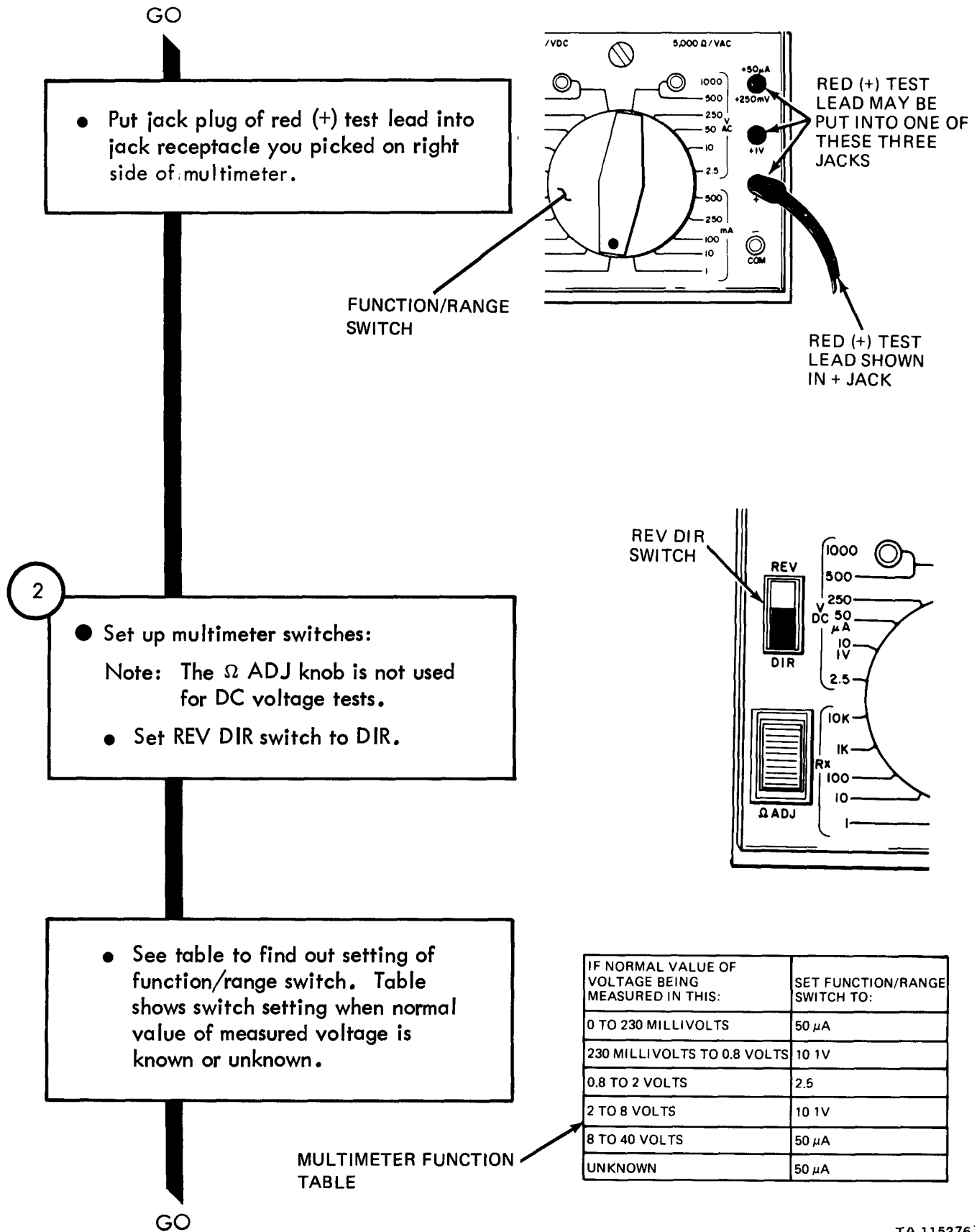

Figure 7-2 (Sheet 2 of 2)

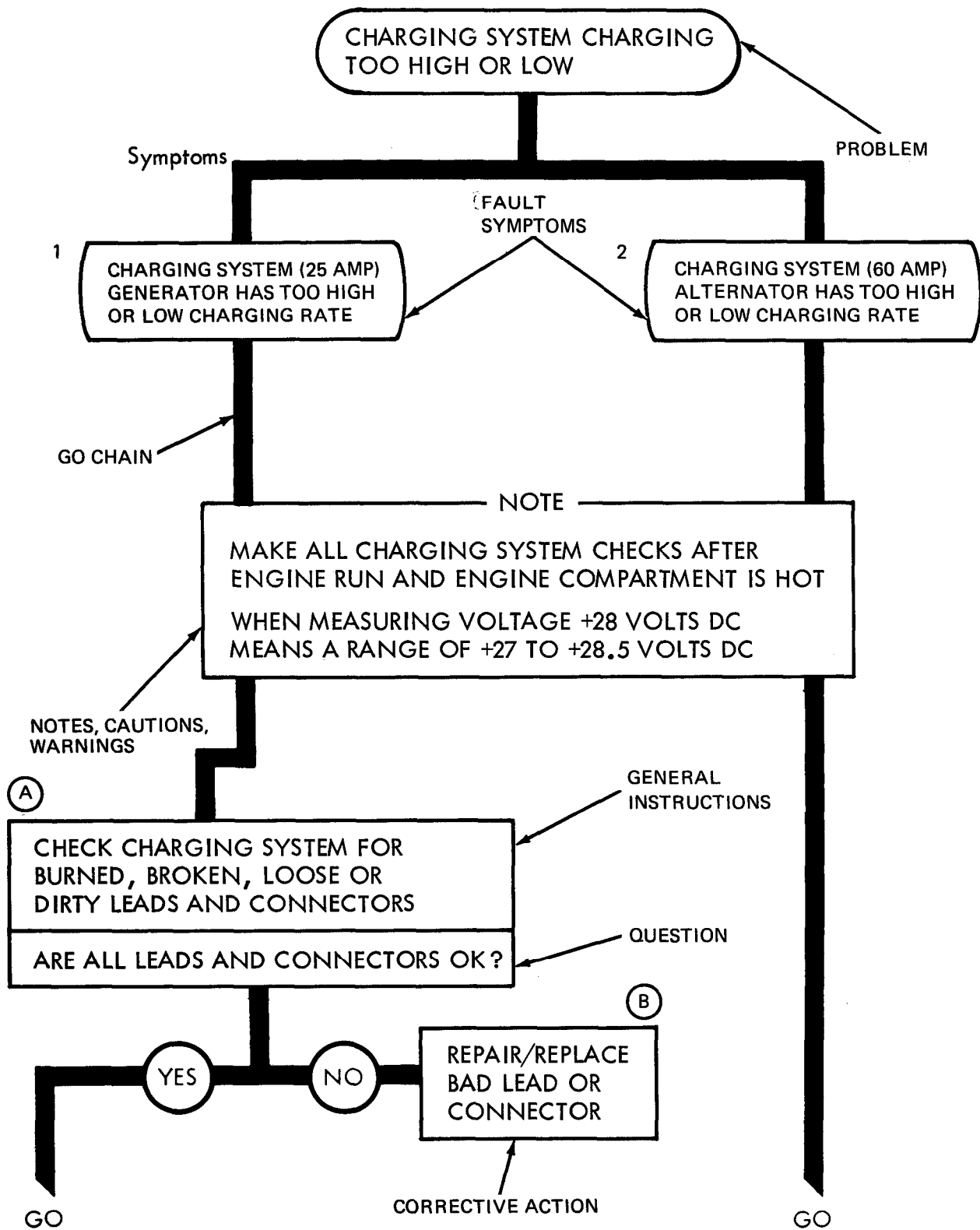

Figure 7-3 (Sheet 1 of 2)

TA 115277

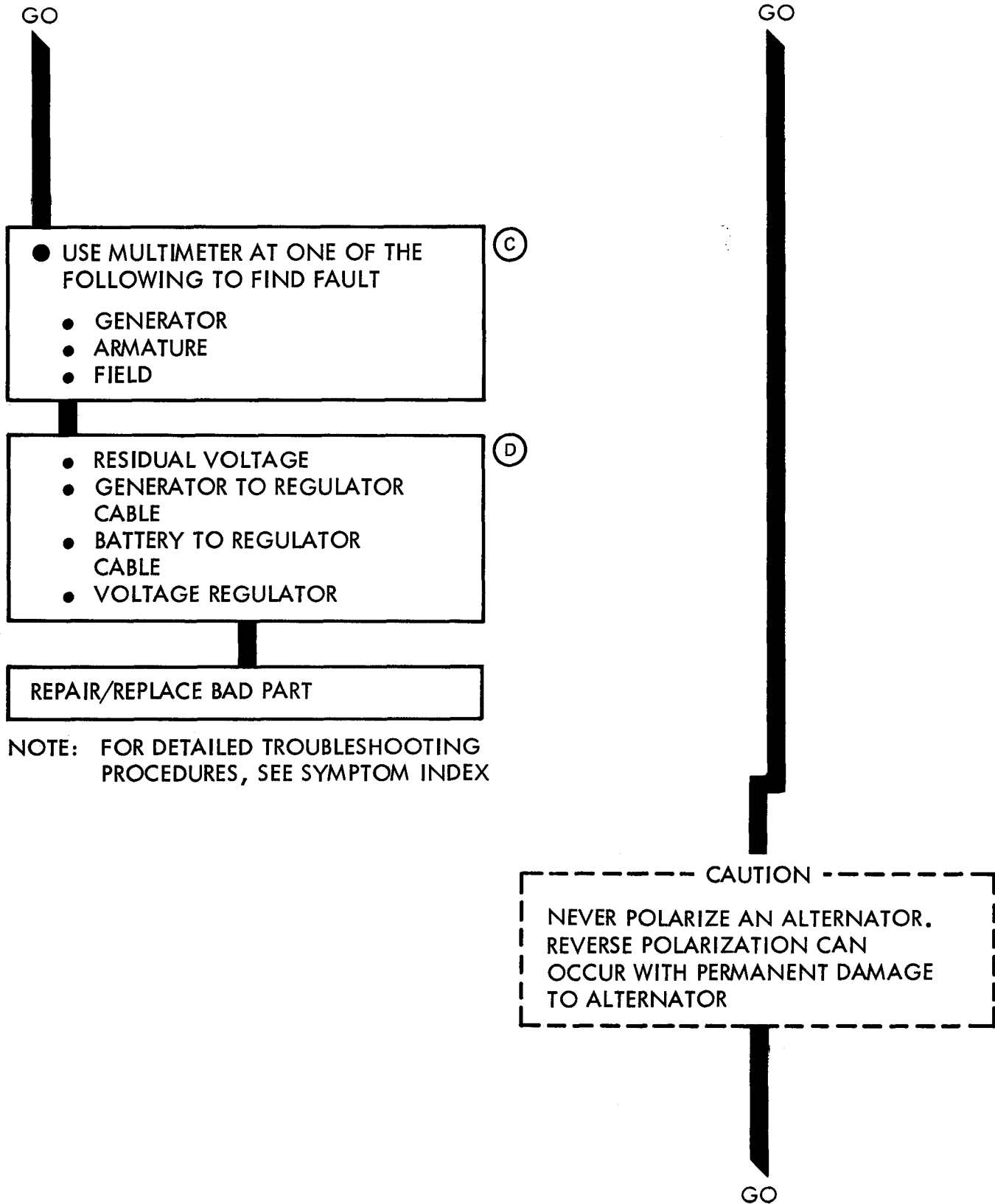

Figure 7-3 (Sheet 2 of 2)

CHAPTER 8

ENGINE SYSTEM TROUBLESHOOTING

8-1. EQUIPMENT ITEMS COVERED. This chapter gives equipment troubleshooting procedures for the engine system, for which there are authorized corrective maintenance tasks at the organizational maintenance level.

8-2. EQUIPMENT ITEMS NOT COVERED. All equipment items for which corrective maintenance is authorized at the organizational maintenance level are covered in this chapter.

ENGINE SYSTEM TROUBLESHOOTING

Symptom

1

LOW OIL PRESSURE

1

- Make truck ready for work on engine
 - Park truck. Refer to TM 9-2320-209-10

2

- Check oil filter gaskets
 - Look for signs of oil leaks at bottom of oil filter body
 - Feel for loose center bolt
- Check oil filter drain plug
 - Look for signs of oil leaking from drain plug

Are oil filter gaskets and oil filter drain plug OK?

GO

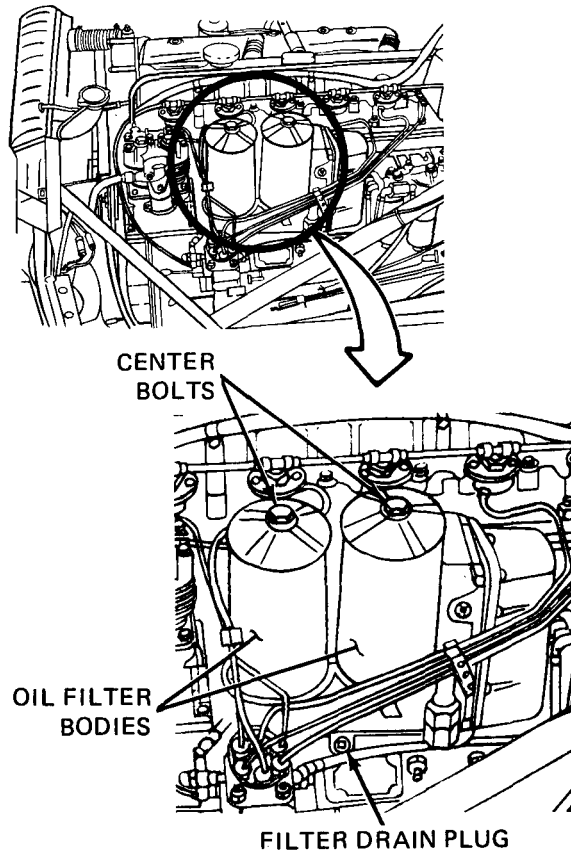

TA 114081

Figure 8-1 (Sheet 1 of 3)

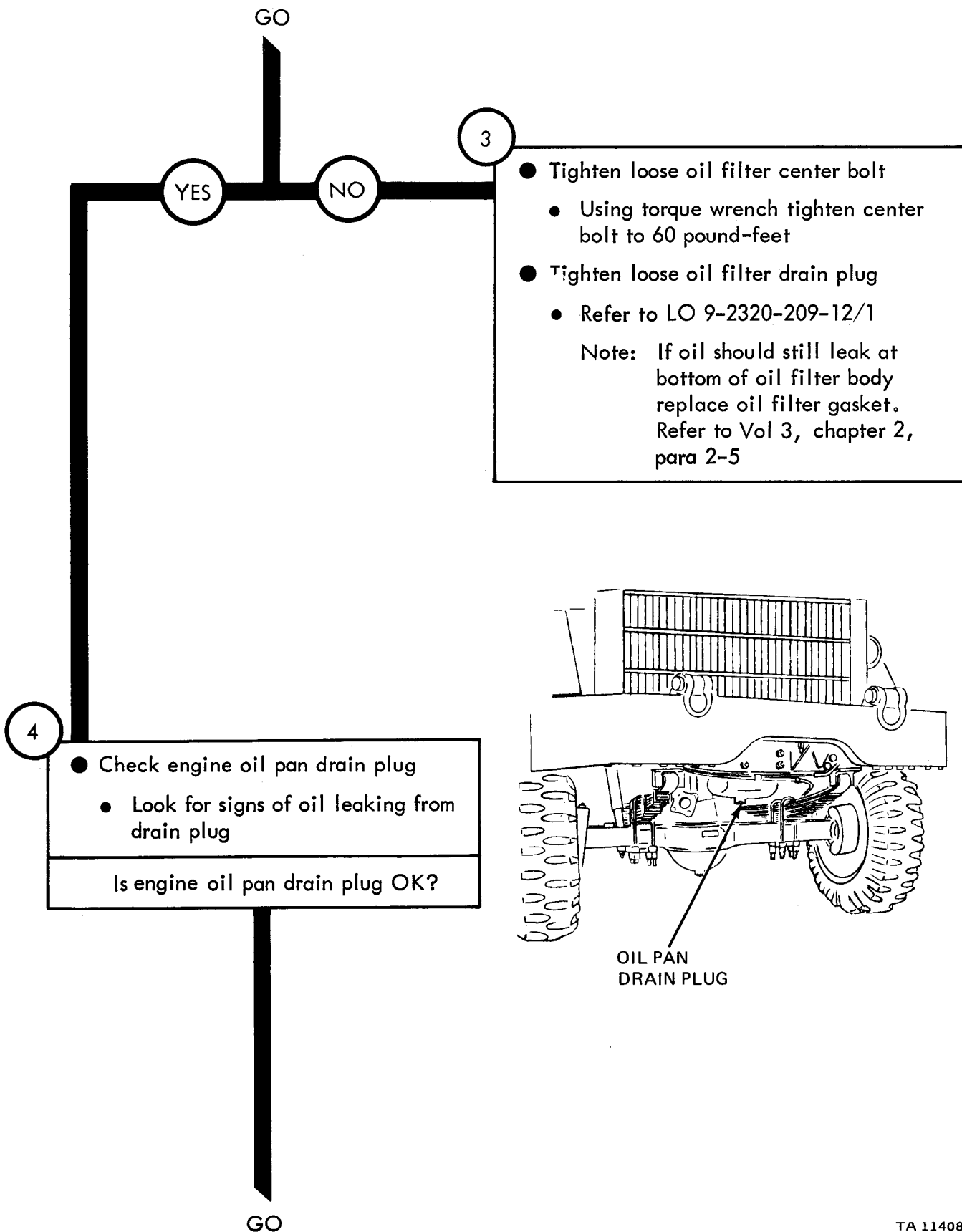

Figure 8-1 (Sheet 2 of 3)

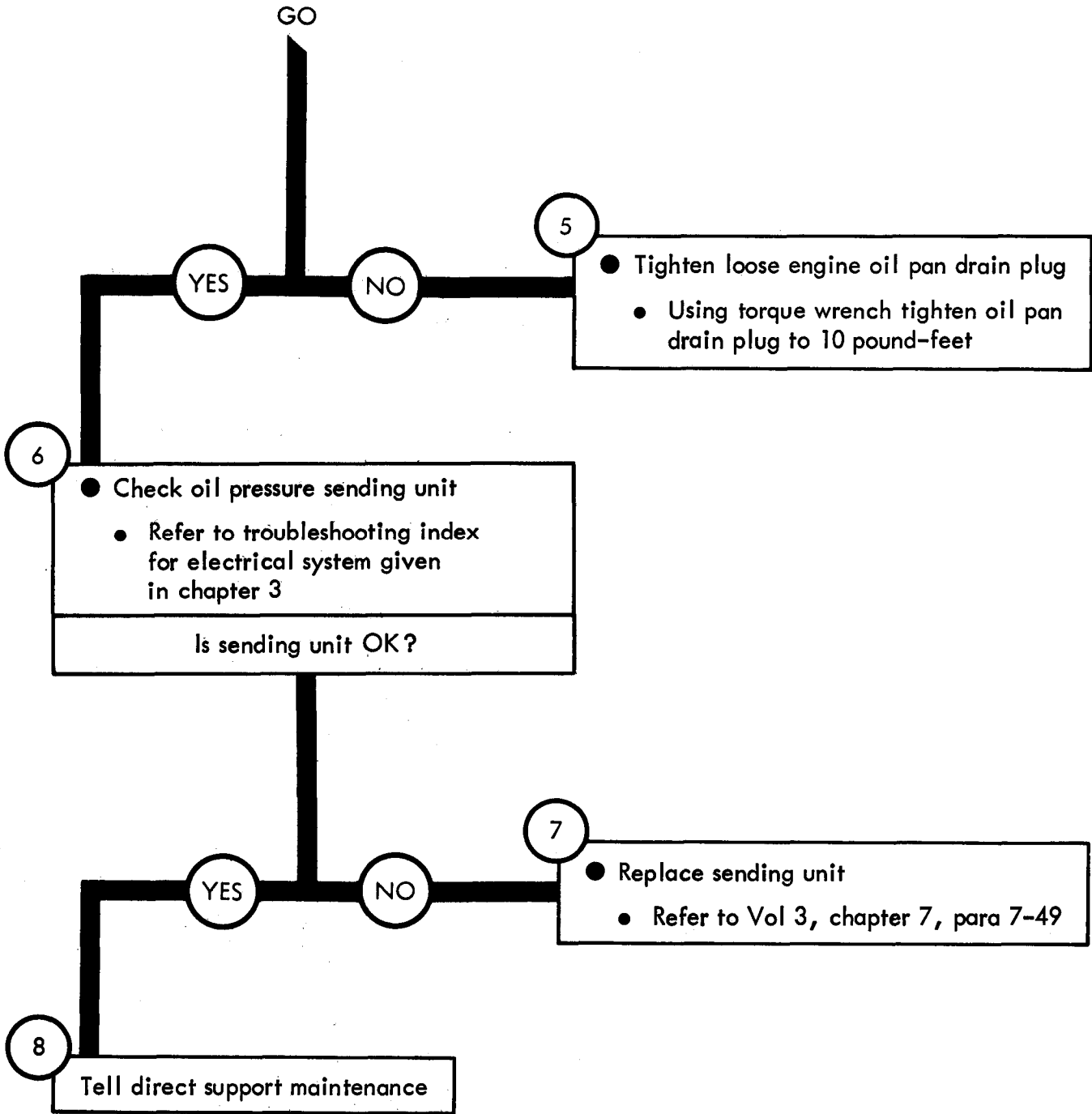

Figure 8-1 (Sheet 3 of 3)

Symptom

2

ENGINE USES MORE OIL THAN NORMAL

1

- Make truck ready for work on engine
 - Park truck. Refer to TM 9-2320-209-10

2

- Check oil filter gaskets
 - Look for signs of oil leaking from bottom of oil filter body
 - Feel for loose center bolt
- Check oil filter drain plug
 - Look for signs of oil leaking from drain plug

Are oil filter gaskets and oil filter drain plug OK?

GO

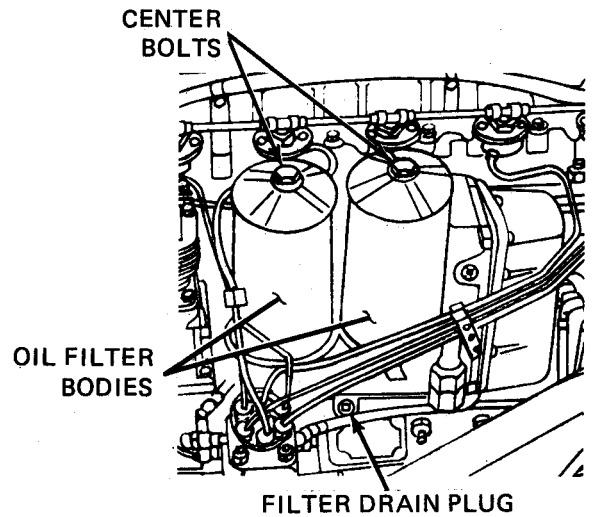
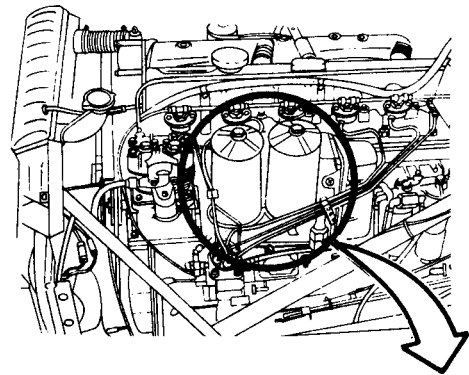
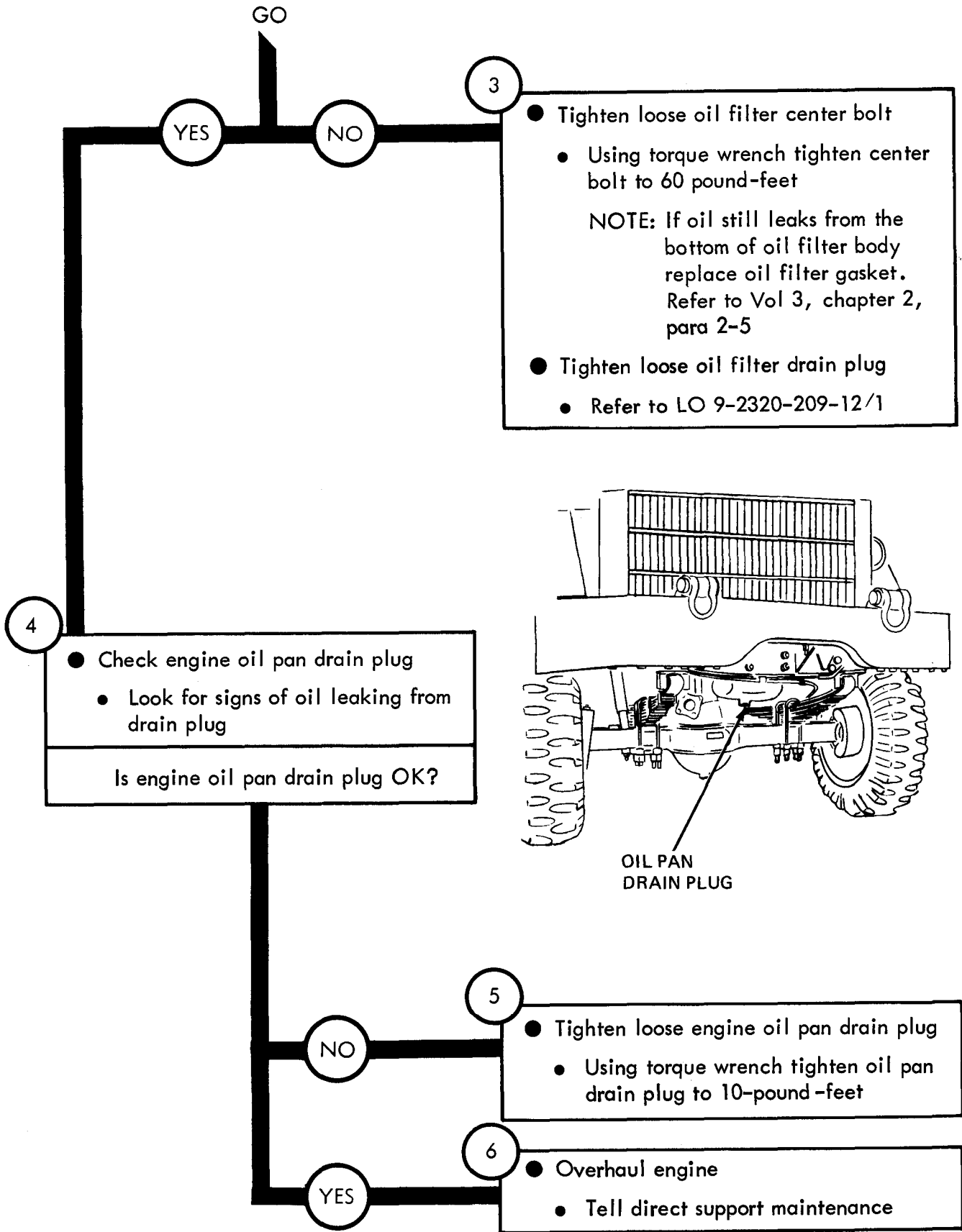

Figure 8-2 (Sheet 1 of 2)



TA 114085

Figure 8-2 (Sheet 2 of 2)

CHAPTER 9

ENGINE SYSTEM TROUBLESHOOTING SUMMARY

9-1. GENERAL. This chapter gives a summary of troubleshooting procedures given in chapter 8 for the engine system.

9-2. PROCEDURES. The summary in this chapter covers all fault symptoms found in the detailed troubleshooting procedures. Chapter 7 outlines a sample troubleshooting procedure. The summary procedures are based on the "what-to-do" portions of the detailed procedures and do not include the "how-to-do-it" instructions. Warnings, cautions, and notes are given where needed.

ENGINE LUBRICATION SUBSYSTEM TROUBLESHOOTING SUMMARY

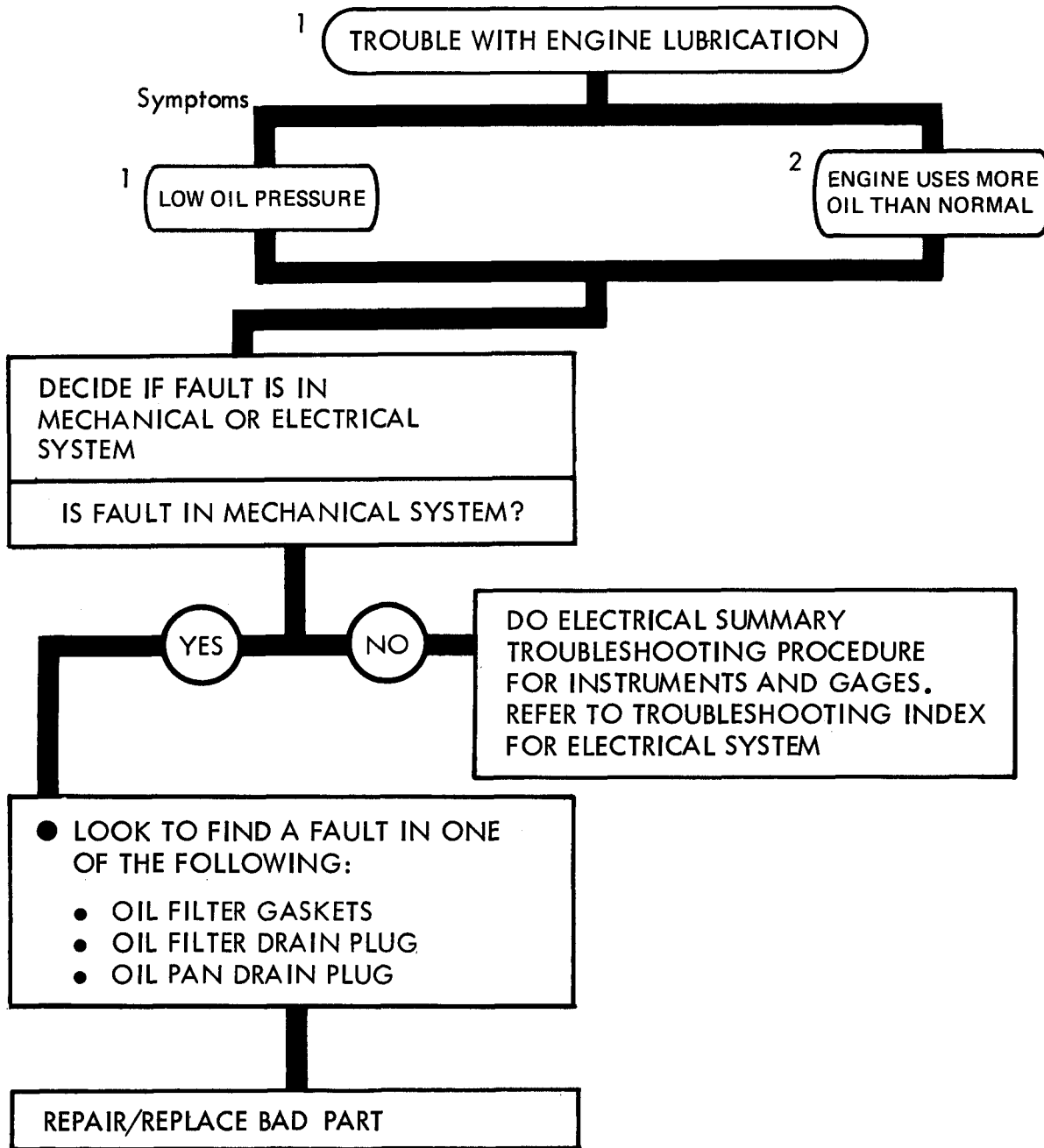

NOTE: FOR DETAILED TROUBLESHOOTING PROCEDURES, SEE SYMPTOM INDEX.

ENGINE SYSTEM - DRIVELINE MOUNTING SUBSYSTEM TROUBLESHOOTING SUMMARY

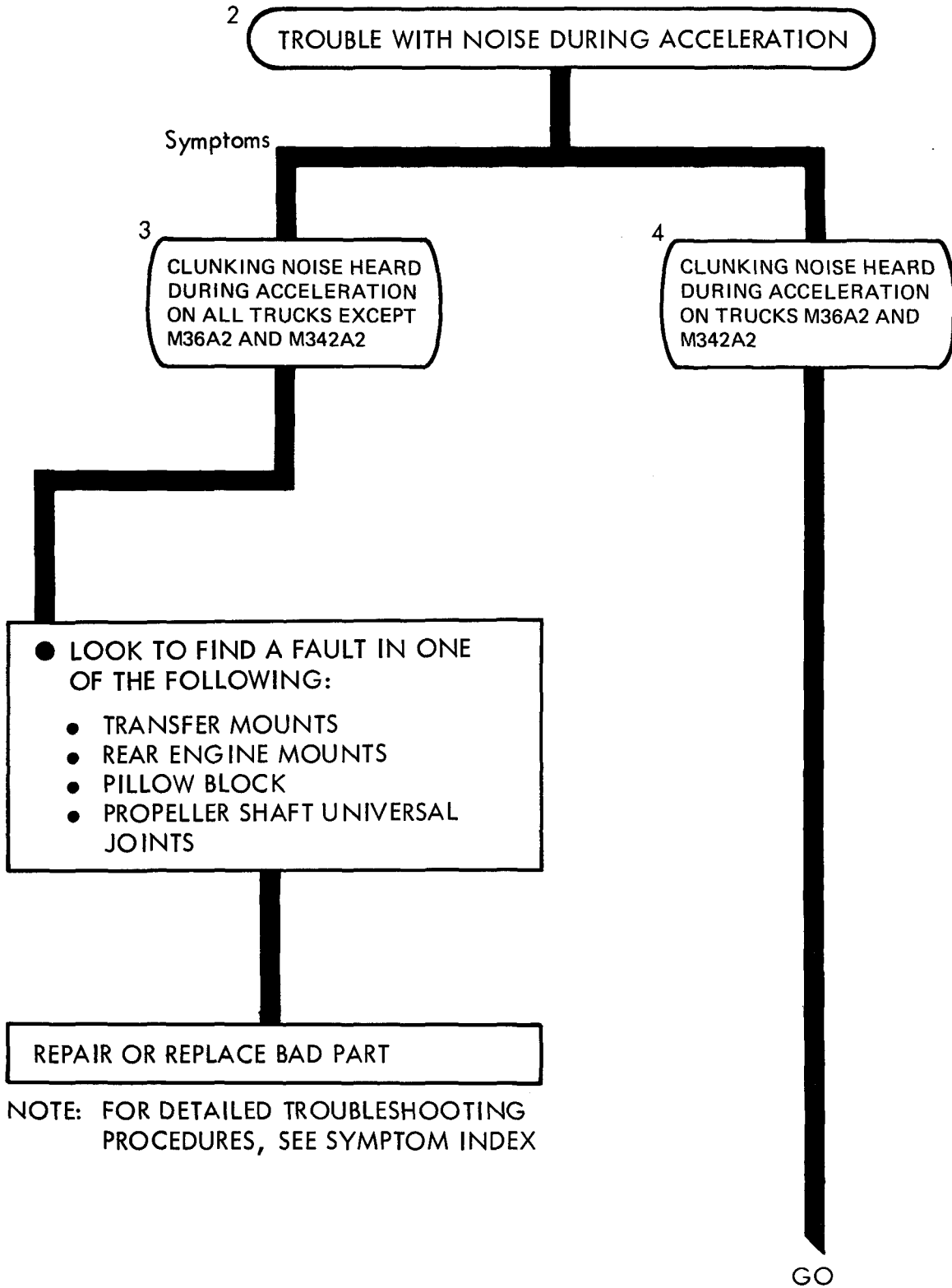

NOTE: FOR DETAILED TROUBLESHOOTING PROCEDURES, SEE SYMPTOM INDEX

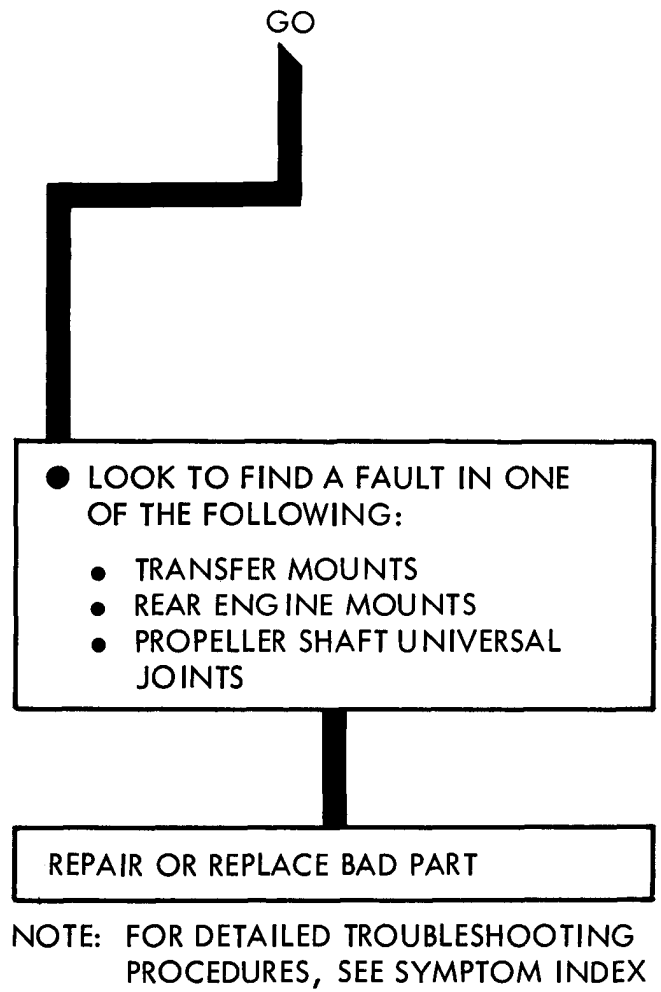

Figure 9-2 (Sheet 2 of 2)

CHAPTER 10

ENGINE DRIVELINE SUBSYSTEM TROUBLESHOOTING

10-1. EQUIPMENT ITEMS COVERED. This chapter gives equipment troubleshooting procedures for the engine driveline subsystem, for which there are authorized corrective maintenance tasks at the organizational maintenance level.

10-2. EQUIPMENT ITEMS NOT COVERED. All equipment items for which corrective maintenance is authorized at the organizational maintenance level are covered in this chapter.

ENGINE DRIVELINE MOUNTING SUBSYSTEM TROUBLESHOOTING

Symptom

1 CLUNKING NOISE HEARD DURING ACCELERATION ON ALL TRUCKS EXCEPT M36A2 AND M342A2

- 1
- Make truck ready for work on engine
 - Park truck. Refer to TM 9-2320-209-10

NOTE

Transfer mounts are not part of the engine system. However the transfer mounts should be checked as a cause of the clunking noise

- 2
- Check transfer mounts
 - Crawl under truck
 - Look for signs that the transfer shifted its position
 - Look for a broken transfer mount
 - Look for missing transfer mounting nuts or bolts
 - Feel for loose transfer mount nuts

Are transfer mounts OK?

GO

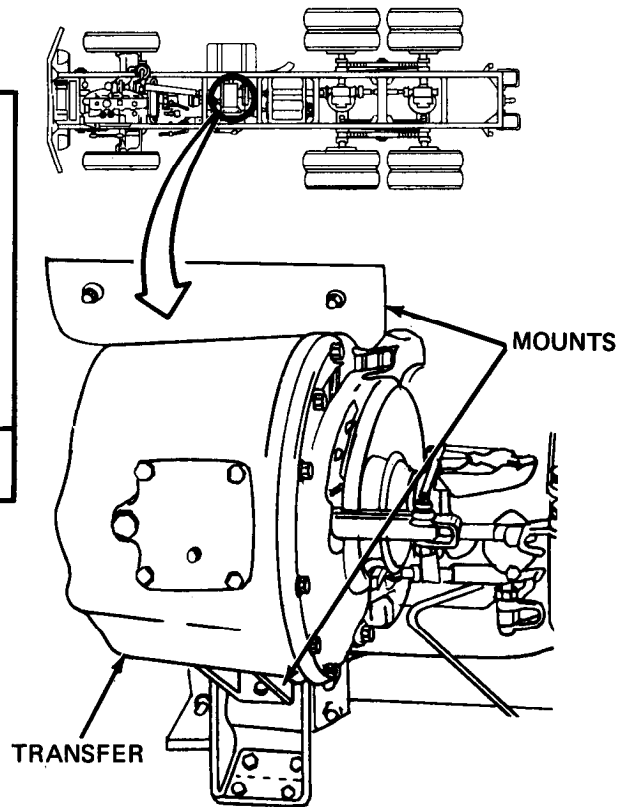

TA 114089

Figure 10-1 (Sheet 1 of 4)

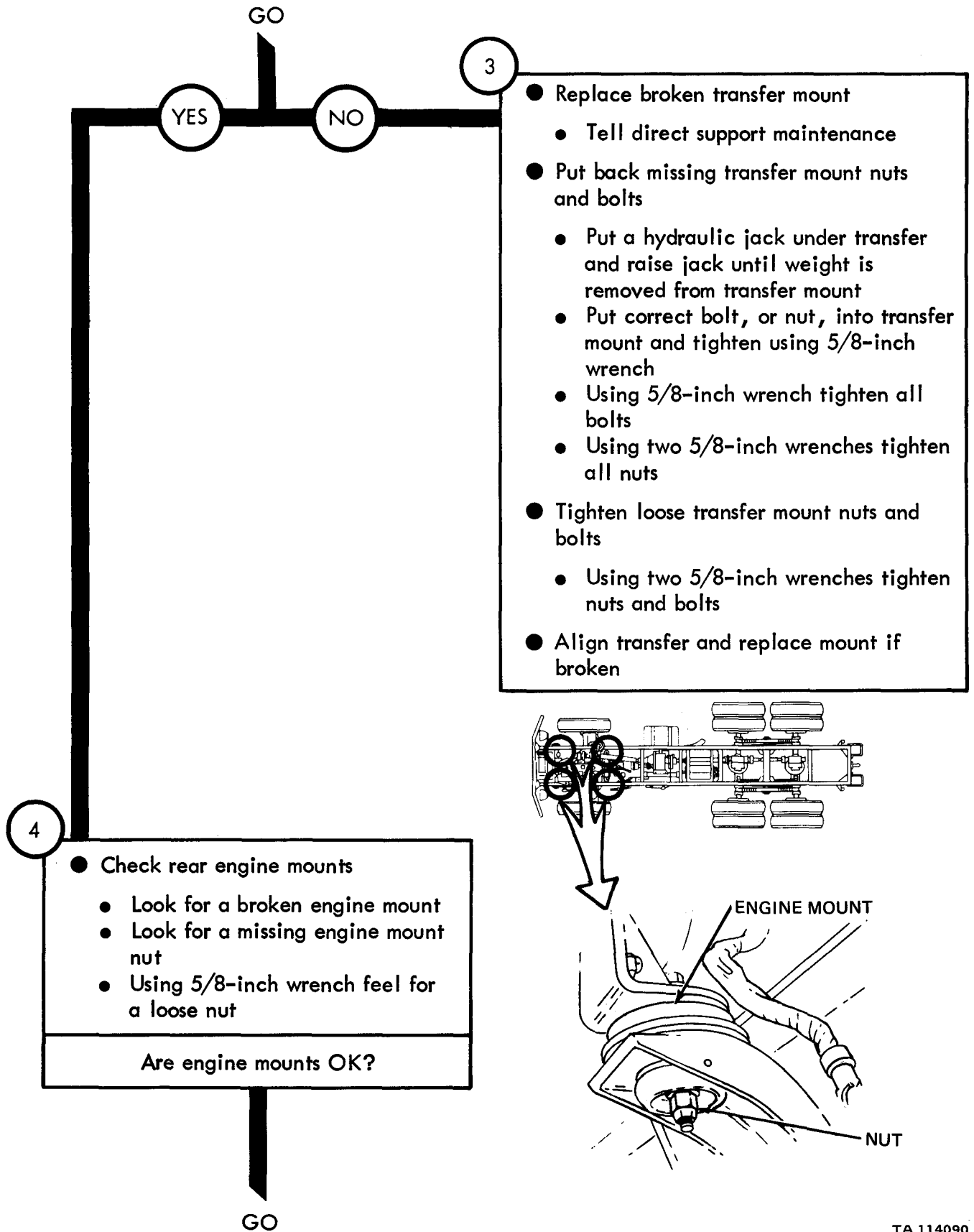
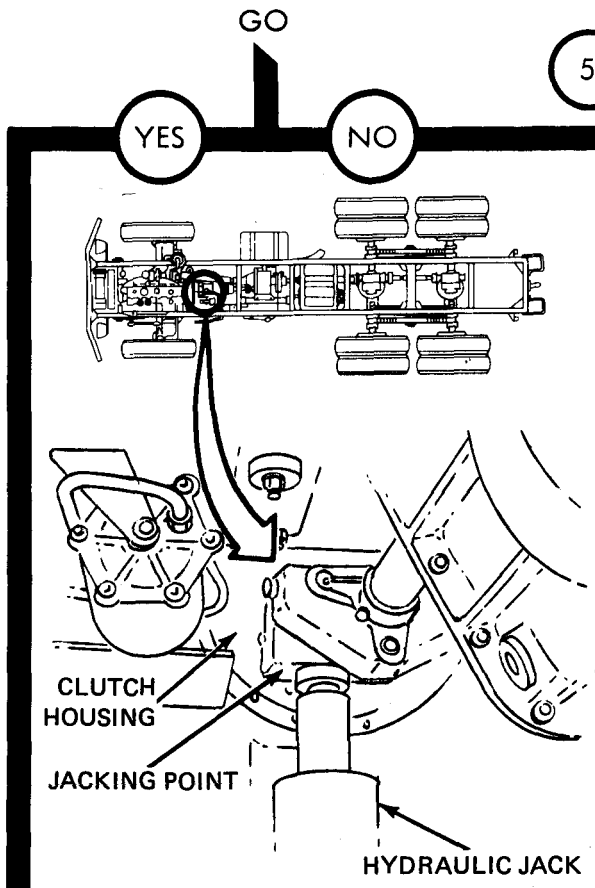

Figure 10-1 (Sheet 2 of 4)

TA 114090



- Replace broken engine mount
 - Refer to Vol 3, chapter 2, para 2-4
- Put back missing engine mount nut
 - Put a hydraulic jack under jacking point and raise jack until weight is removed from engine mount
 - Put correct nut onto engine mount and screw on until hand tight
 - Using two 5/8-inch wrenches tighten engine mount
- Tighten loose engine mount nut
 - Using two 5/8-inch wrenches tighten engine mount

NOTE

Propeller shafts and universal joints are not part of the engine system. However they should be checked as a cause of the clunking noise

GO

Figure 10-1 (Sheet 3 of 4)

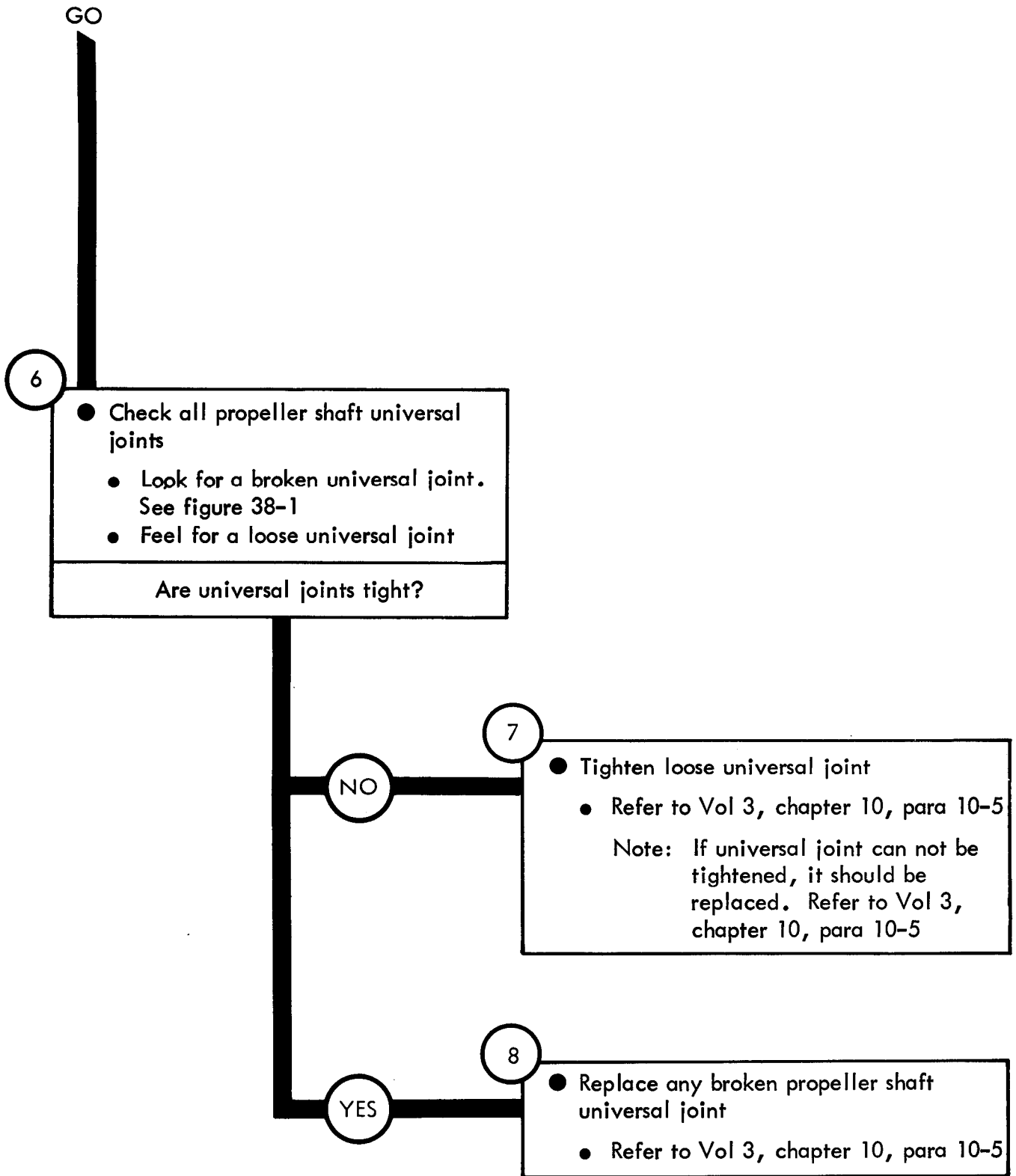

Symptom

2 CLUNKING NOISE HEARD DURING ACCELERATION ON TRUCKS M36A2 AND M342A2

- 1
- Make truck ready for work on propeller shafts
 - Park truck. Refer to TM 9-2320-209-10
 - Chock wheels

NOTE

Transfer mounts are not part of the engine system. However the transfer mounts should be checked as a cause of the clunking noise

- 2
- Check transfer mounts
 - Crawl under truck
 - Look for signs that the transfer shifted its position
 - Look for a broken transfer mount
 - Look for missing transfer mounting nuts or bolts
 - Feel for loose transfer mount nuts
- Are transfer mounts OK?

GO

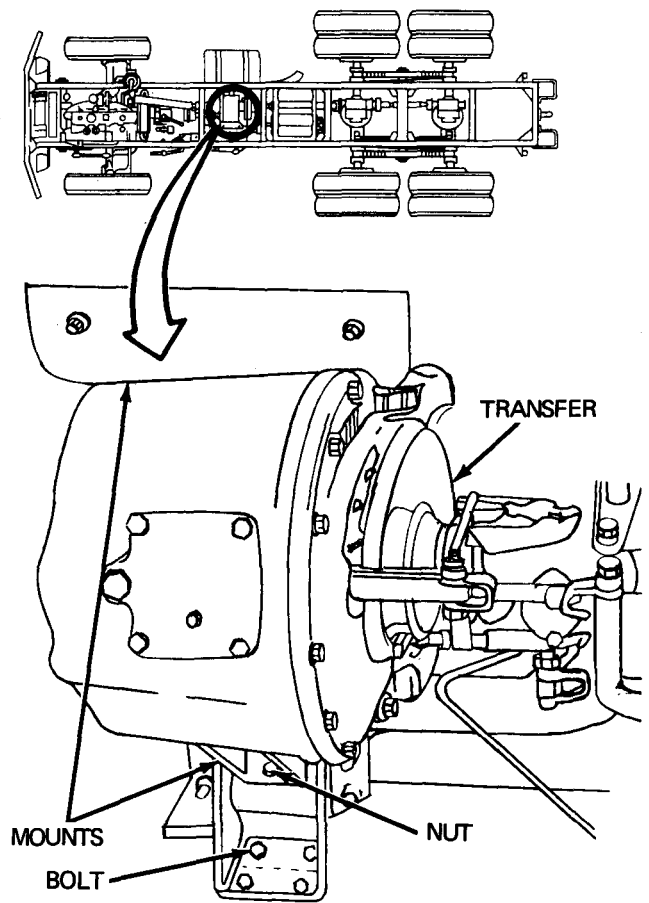

TA 114093

Figure 10-2 (Sheet 1 of 4)

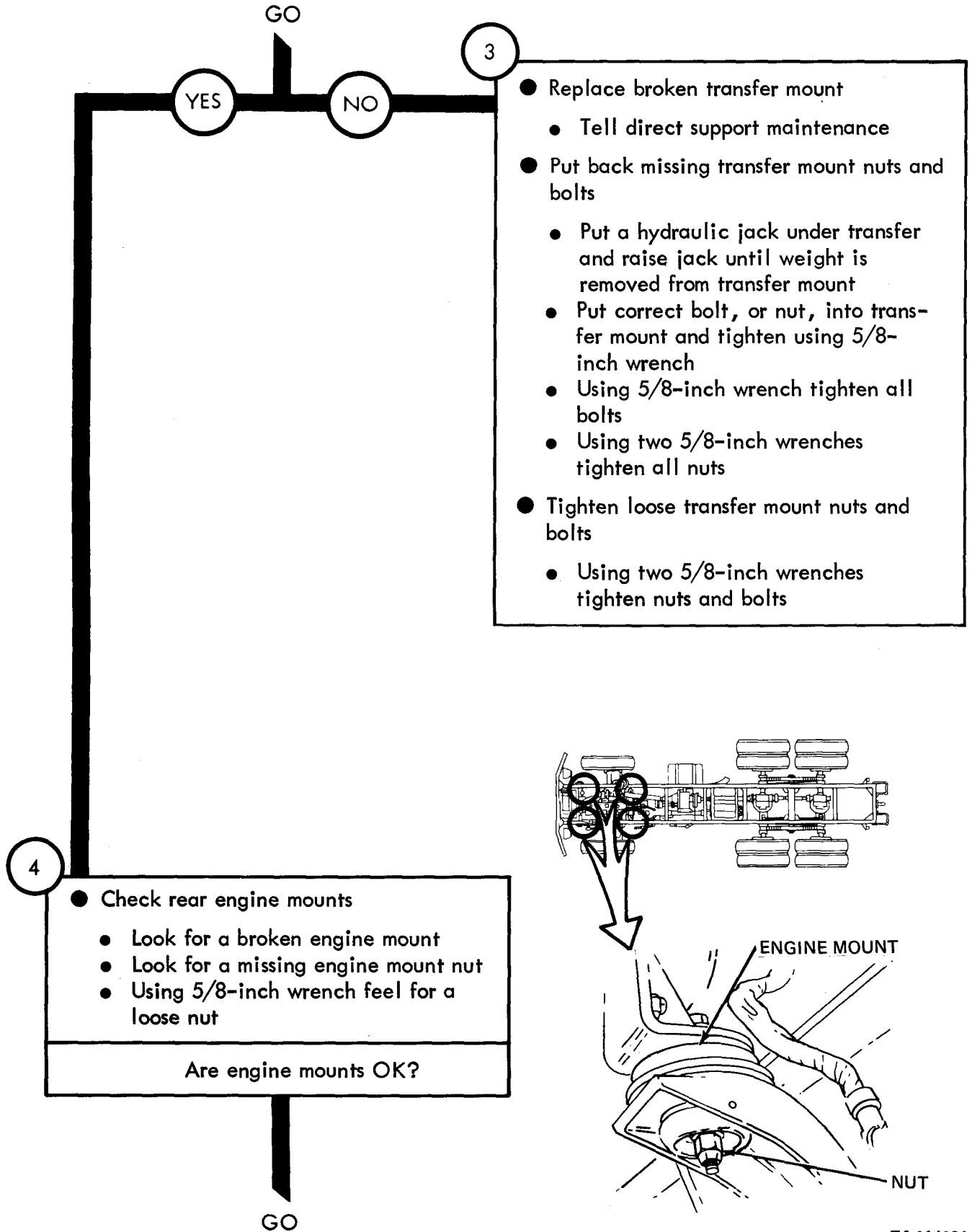

TA 114094

Figure 10-2 (Sheet 2 of 4)

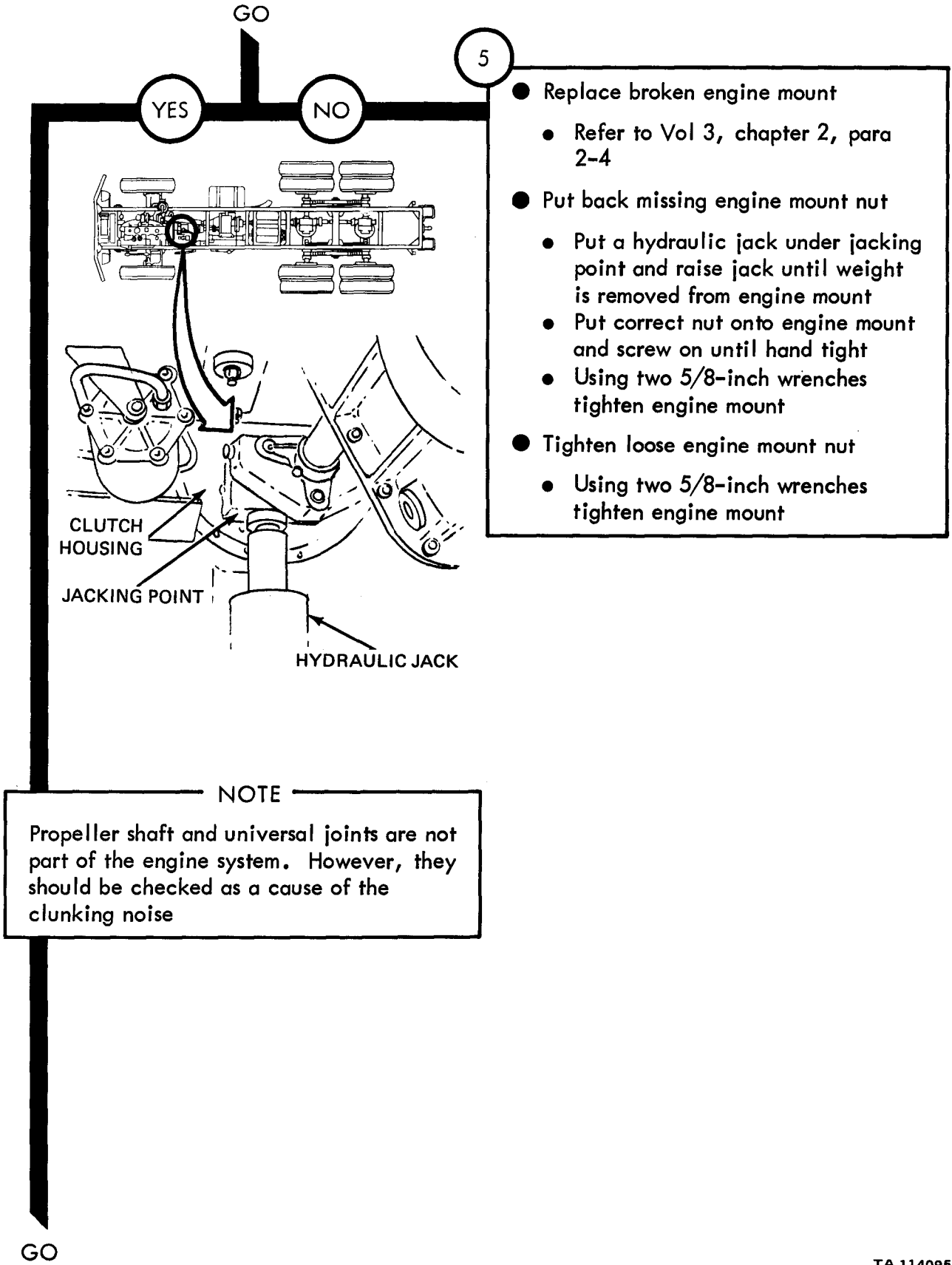

- 5
- Replace broken engine mount
 - Refer to Vol 3, chapter 2, para 2-4
 - Put back missing engine mount nut
 - Put a hydraulic jack under jacking point and raise jack until weight is removed from engine mount
 - Put correct nut onto engine mount and screw on until hand tight
 - Using two 5/8-inch wrenches tighten engine mount
 - Tighten loose engine mount nut
 - Using two 5/8-inch wrenches tighten engine mount

NOTE

Propeller shaft and universal joints are not part of the engine system. However, they should be checked as a cause of the clunking noise

Figure 10-2 (Sheet 3 of 4)

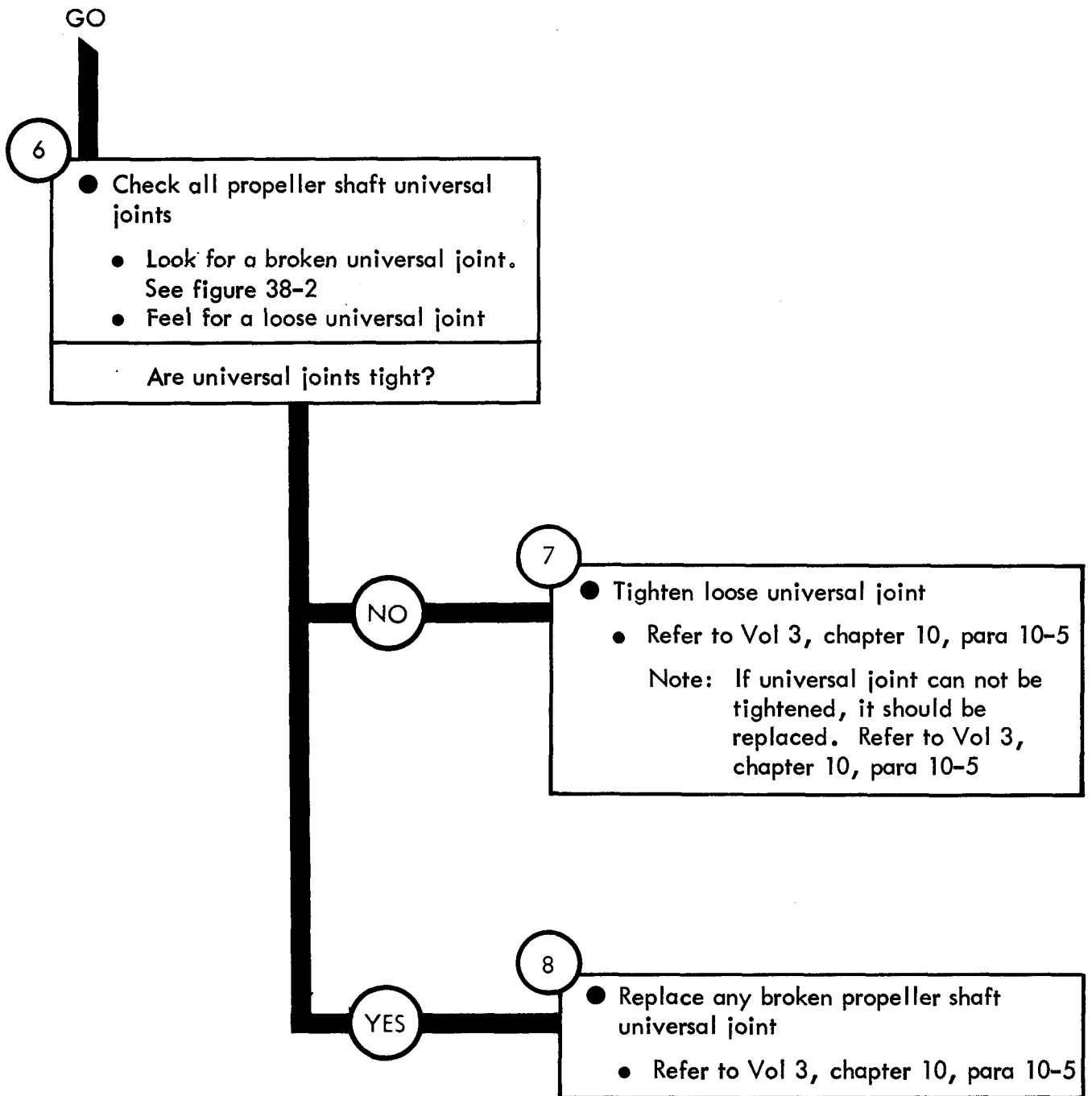

CHAPTER 11

CLUTCH SYSTEM TROUBLESHOOTING

11-1. EQUIPMENT ITEMS COVERED. This chapter gives equipment troubleshooting procedures for the clutch system for which there are authorized corrective maintenance tasks at the organizational maintenance level.

11-2. EQUIPMENT ITEMS NOT COVERED. All equipment items for which corrective maintenance is authorized at the organizational maintenance level are covered in this chapter.

CLUTCH SYSTEM TROUBLESHOOTING

Symptom

1 TRUCK CREEPS WHEN CLUTCH PEDAL IS PRESSED

- 1
- Make truck ready for work on clutch
 - Park truck. Refer to TM 9-2320-209-10
 - Chock wheels

- 2
- Check clutch pedal free travel
 - Slowly push down on clutch pedal
 - Feel if pedal travels freely for about 1 1/2 to 2 inches before clutch lets go
- Is clutch pedal free play OK?

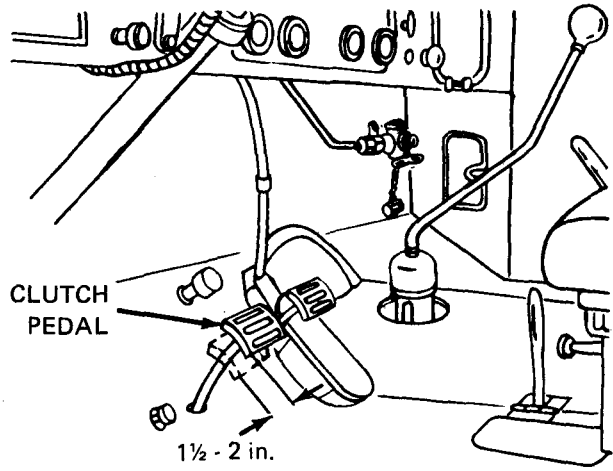

- NO
- 3
- Adjust clutch pedal free play
 - Refer to Vol 3, chapter 3, para 3-3
- YES
- 4
- Replace clutch
 - Tell direct support maintenance

TA 114097

Figure 11-1

Symptom

2

CLUTCH, DRAGS, SLIPS, OR DOES NOT ENGAGE

1

- Make truck ready for work on clutch
 - Park truck. Refer to TM 9-2320-209-10
 - Chock wheels

2

- Check clutch linkage
 - Move clutch linkage to feel if it is binding
 - Look for bent linkage
- Is clutch linkage OK?

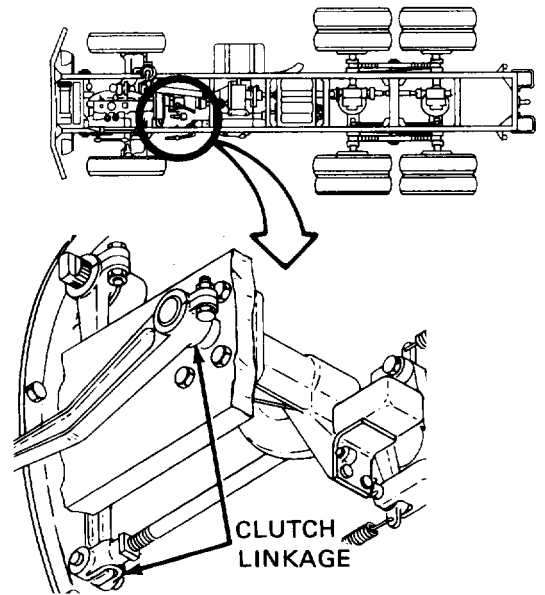

3

- Lubricate binding linkage
 - Refer to LO 9-2320-209-12/1
- Replace bent linkage
 - Refer to Vol 3, chapter 3, para 3-3

YES

NO

GO

TA 114098

Figure 11-2 (Sheet 1 of 2)

GO

4

● Check clutch pedal free play

- Slowly push down on clutch pedal
- Feel if pedal travels freely for about 1 1/2 to 2 inches before clutch lets go

Is clutch pedal free play OK?

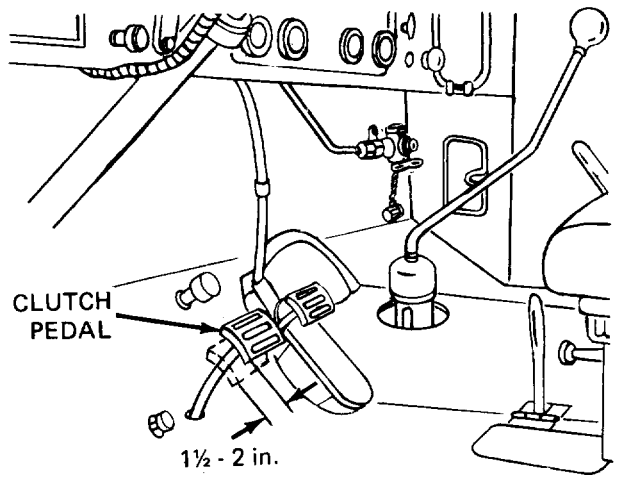

NO

5

● Adjust clutch pedal free play

- Refer to Vol 3, chapter 3, para 3-3

YES

6

● Replace clutch

- Tell direct support maintenance

Figure 11-2 (Sheet 2 of 2)

CHAPTER 12

CLUTCH SYSTEM TROUBLESHOOTING SUMMARY

12-1. GENERAL. This chapter gives a summary of troubleshooting procedures given in chapter 11 for the clutch system.

12-2. PROCEDURES. The summary in this chapter covers all fault symptoms found in the detailed troubleshooting procedures. Chapter 7 outlines a sample troubleshooting procedure. The summary procedures are based on the "what-to-do" portions of the detailed procedures and do not include the "how-to-do-it" instructions. Warnings, cautions, and notes are given where needed.

CLUTCH SYSTEM TROUBLESHOOTING SUMMARY

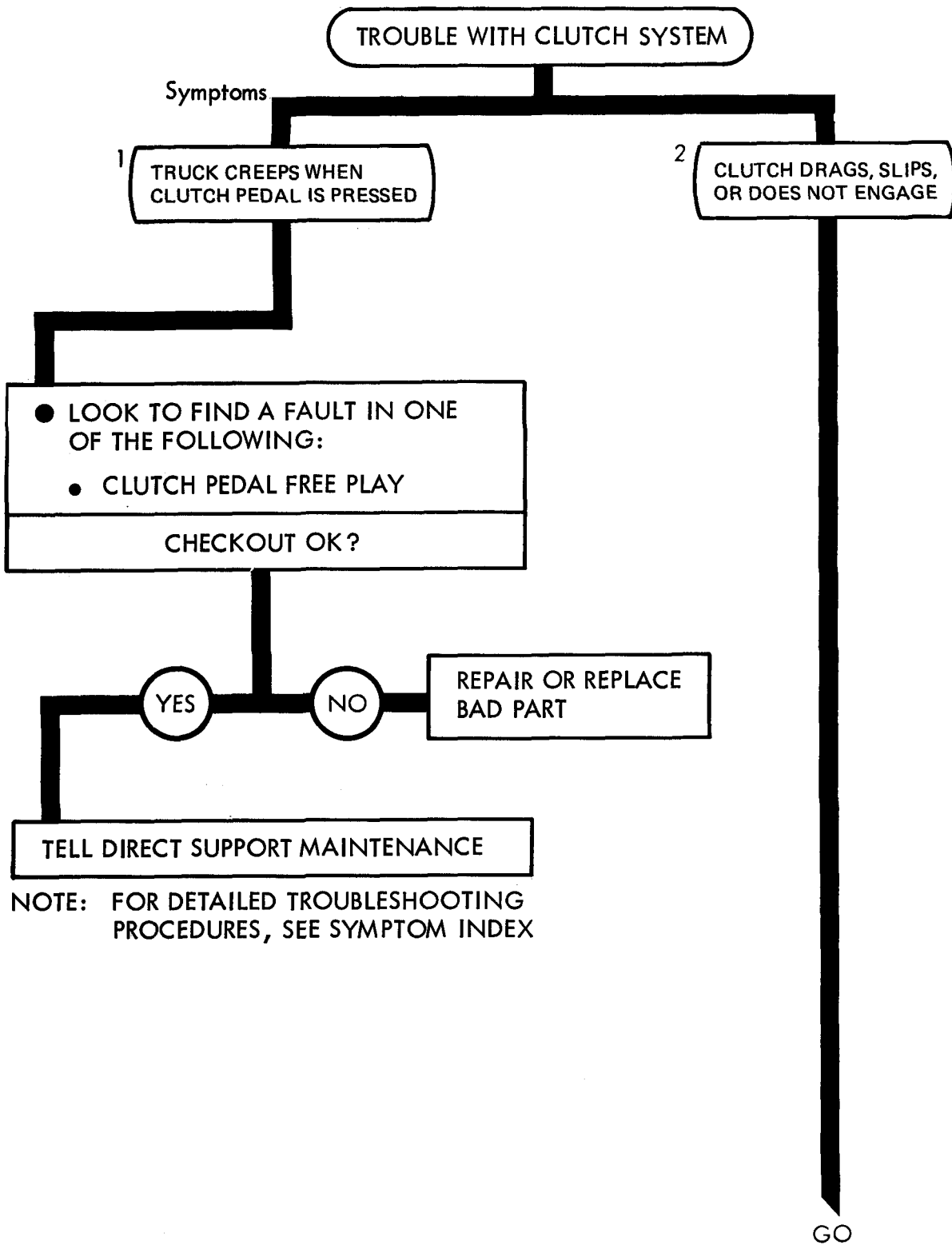

NOTE: FOR DETAILED TROUBLESHOOTING PROCEDURES, SEE SYMPTOM INDEX

Figure 12-1 (Sheet 1 of 2)

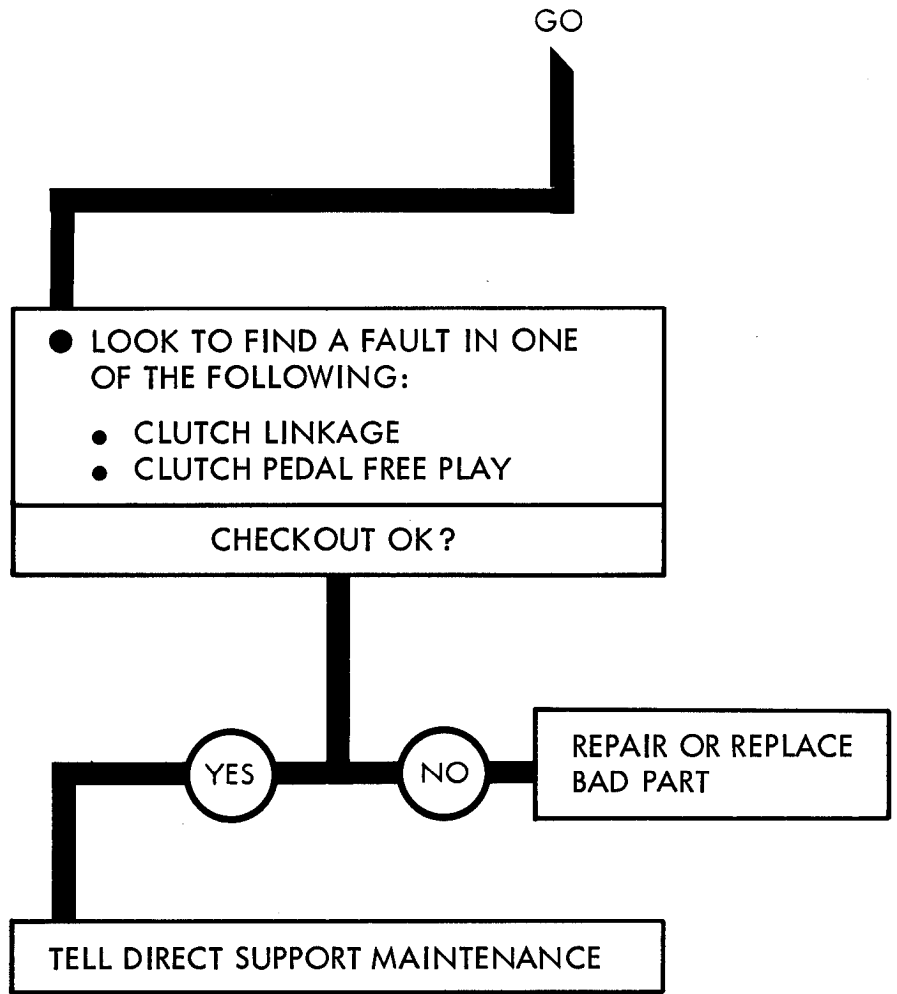

NOTE: FOR DETAILED TROUBLESHOOTING PROCEDURES, SEE SYMPTOM INDEX

CHAPTER 13

FUEL SYSTEM TROUBLESHOOTING

13-1. EQUIPMENT ITEMS COVERED. This chapter gives equipment troubleshooting procedures for the fuel system, for which there are authorized corrective maintenance tasks at the organizational maintenance level.

13-2. EQUIPMENT ITEMS NOT COVERED. All equipment items for which corrective maintenance is authorized at the organizational maintenance level are covered in this chapter.

Symptom

1 ENGINE CRANKS BUT DOES NOT START

WARNING

Diesel fuel is very flammable. Care must be used when choosing a place to work on fuel system. Keep truck about 50 feet away from an area where open flame, sparks, or smoking may cause a fire. Keep a fire extinguisher close by

1

- Make truck ready for work on fuel system
 - Find a well ventilated area
 - *Park truck. Refer to TM 9-2320-209-10*

2

- Check manifold heater fuel lines
 - Look for a crushed or broken line. See fig 15-1
 - Look for signs of fuel leaking from lines or fittings
 - Feel for loose fittings
- Check all fuel lines and fittings
 - Fuel line and fitting checks given in figure 16-4

Are manifold heater and engine fuel lines and fittings OK?

GO

Figure 13-1 (Sheet 1 of 6)

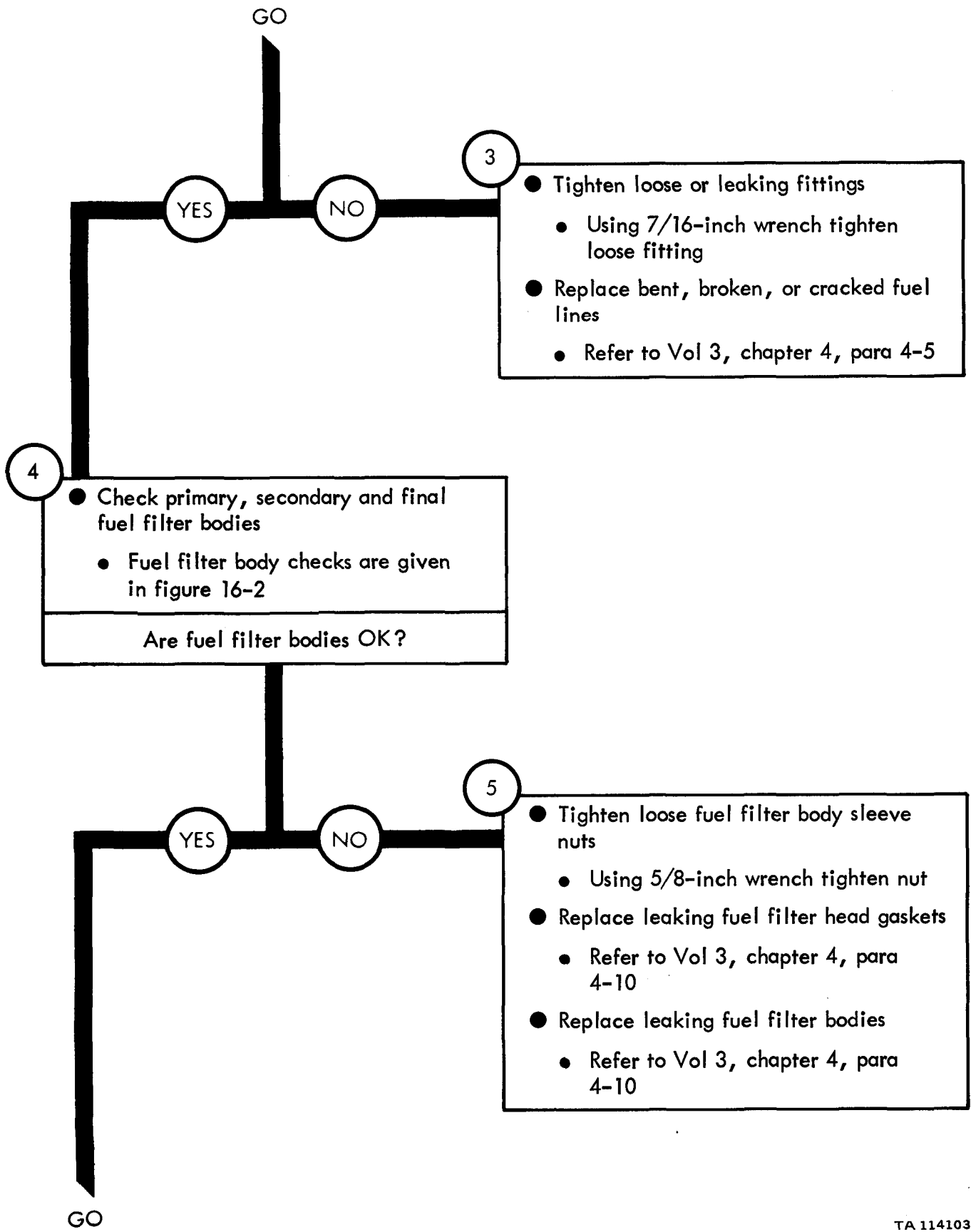

Figure 13-1 (Sheet 2 of 6)

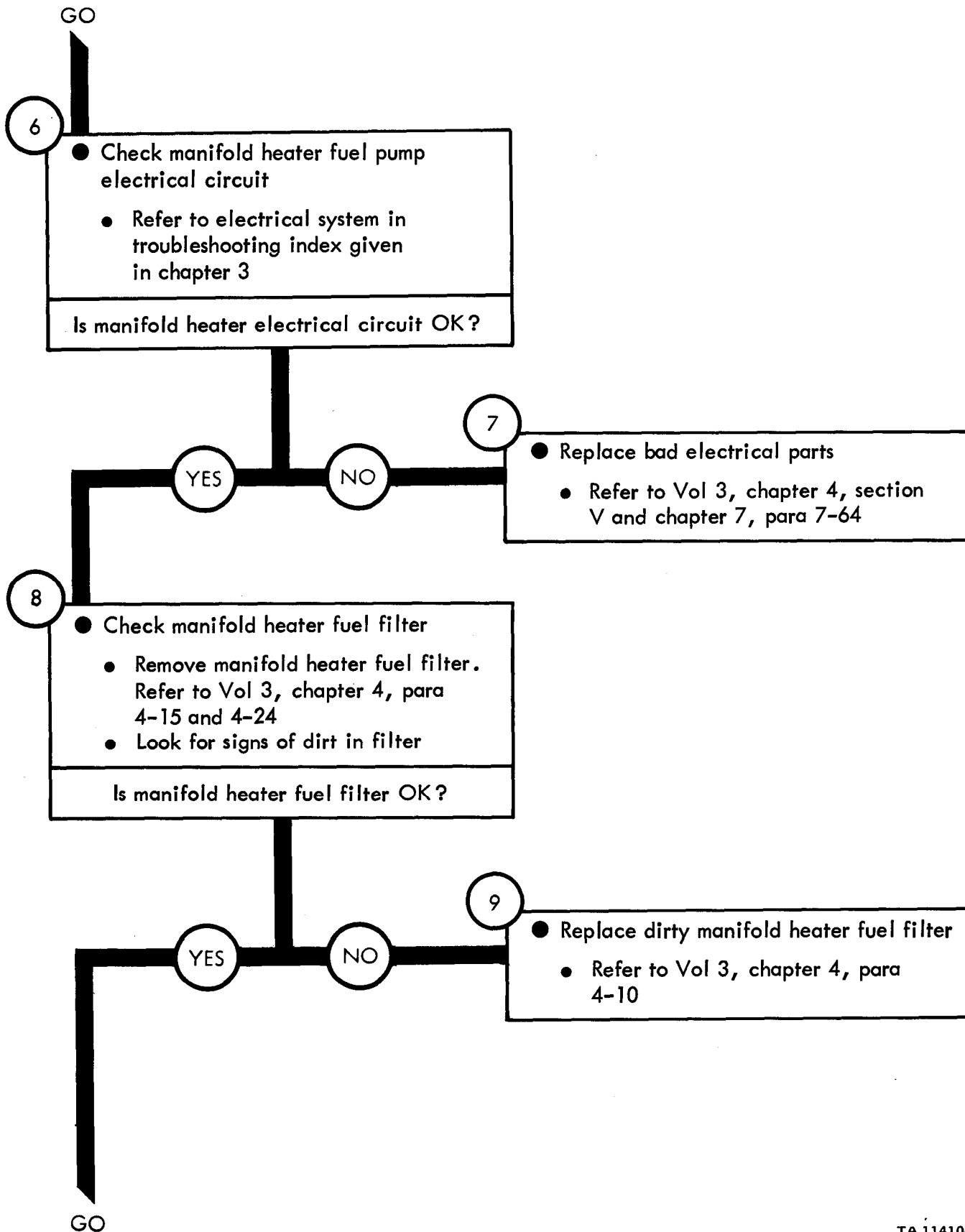
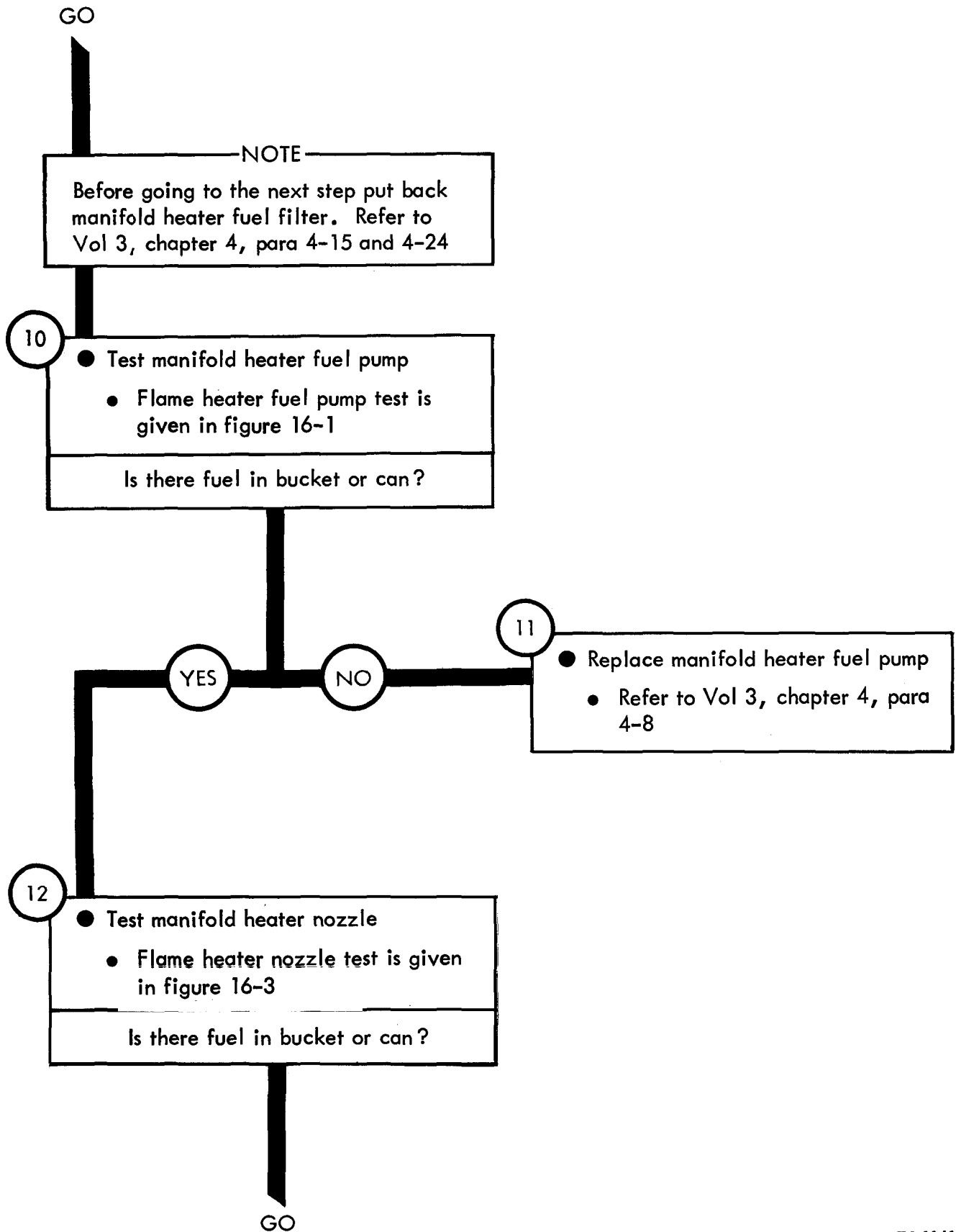
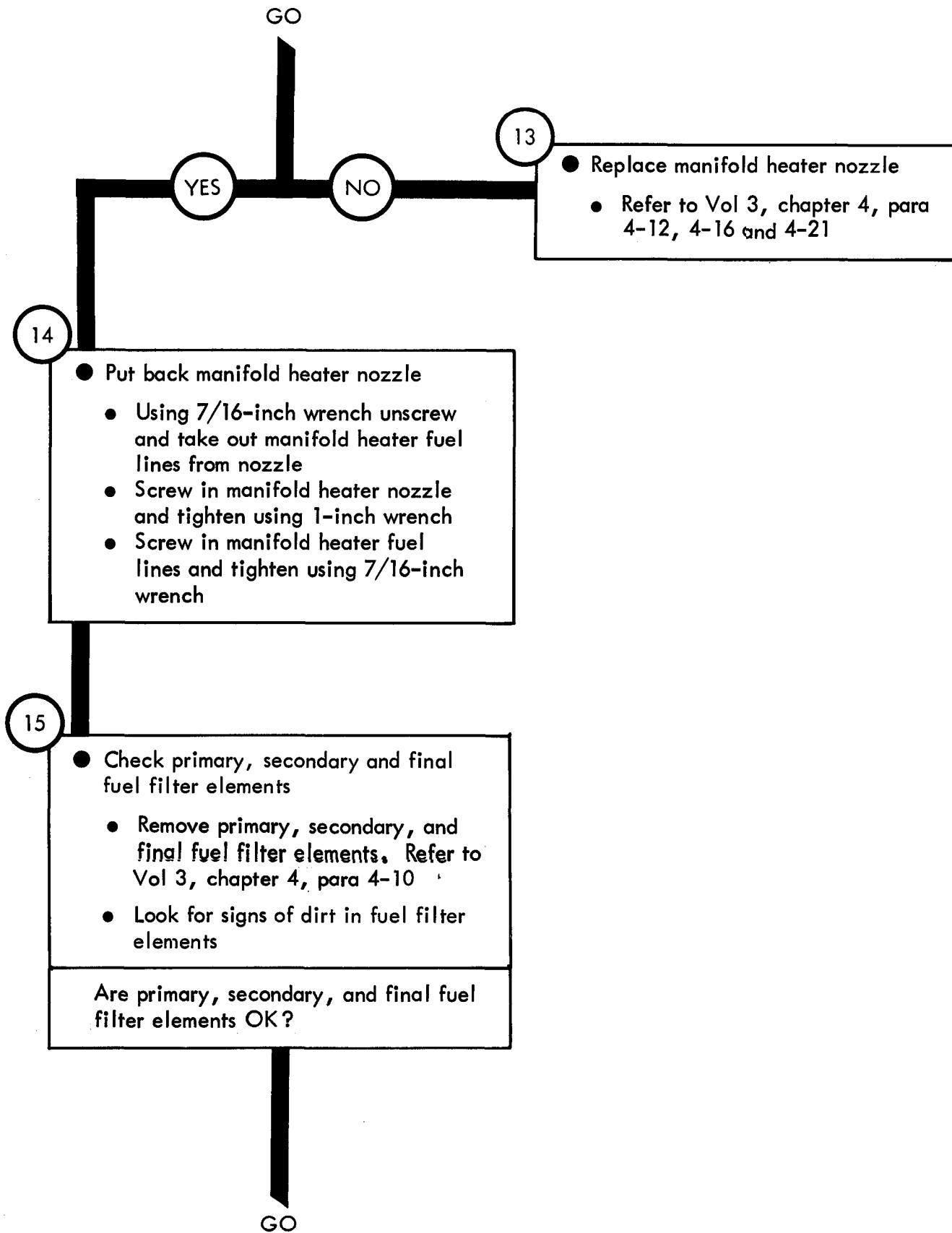

Figure 13-1 (Sheet 3 of 6)



TA 114105

Figure 13-1 (Sheet 4 of 6)



TA 114106

Figure 13-1 (Sheet 5 of 6)

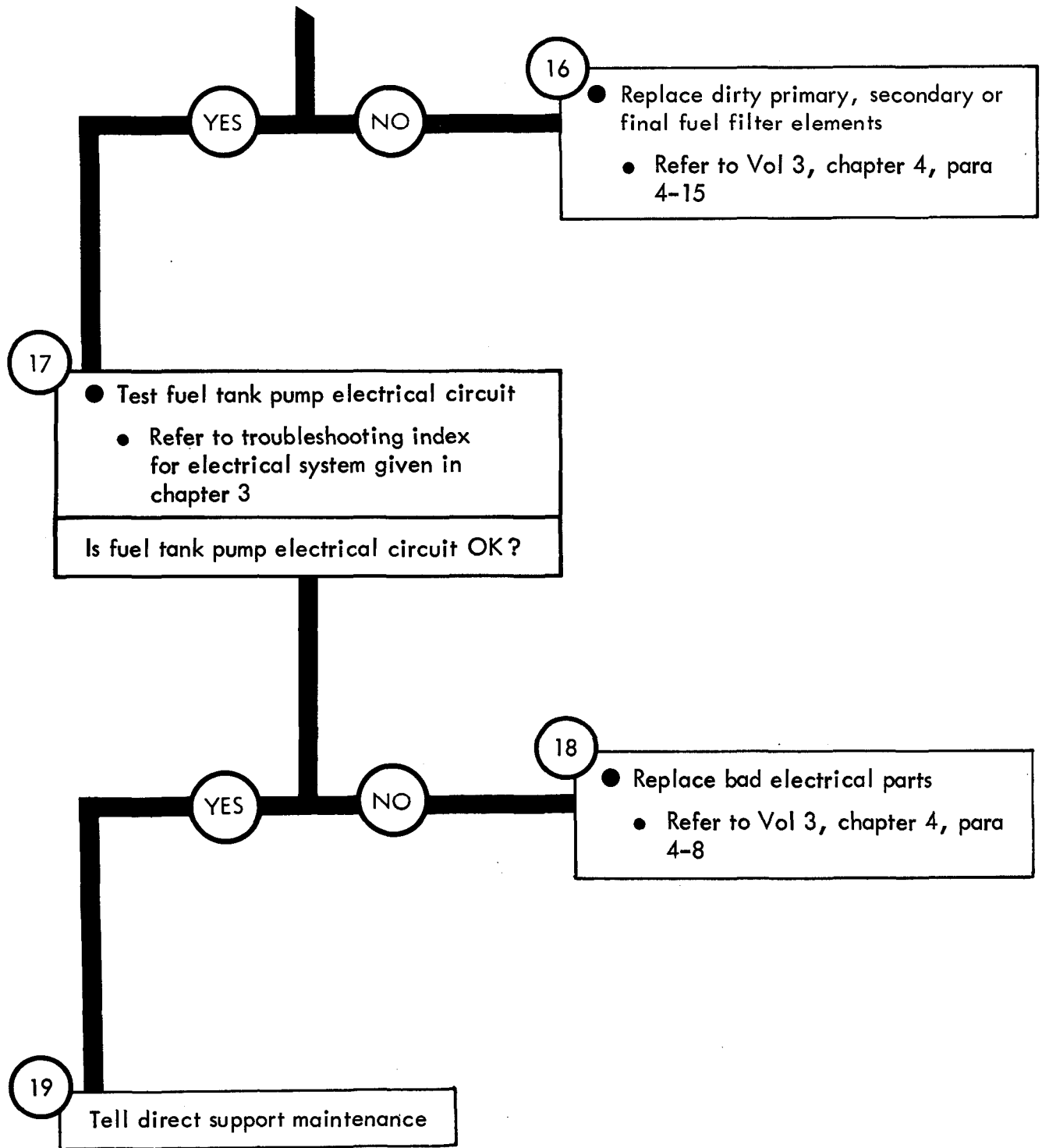

TA 114107

Figure 13-1 (Sheet 6 of 6)

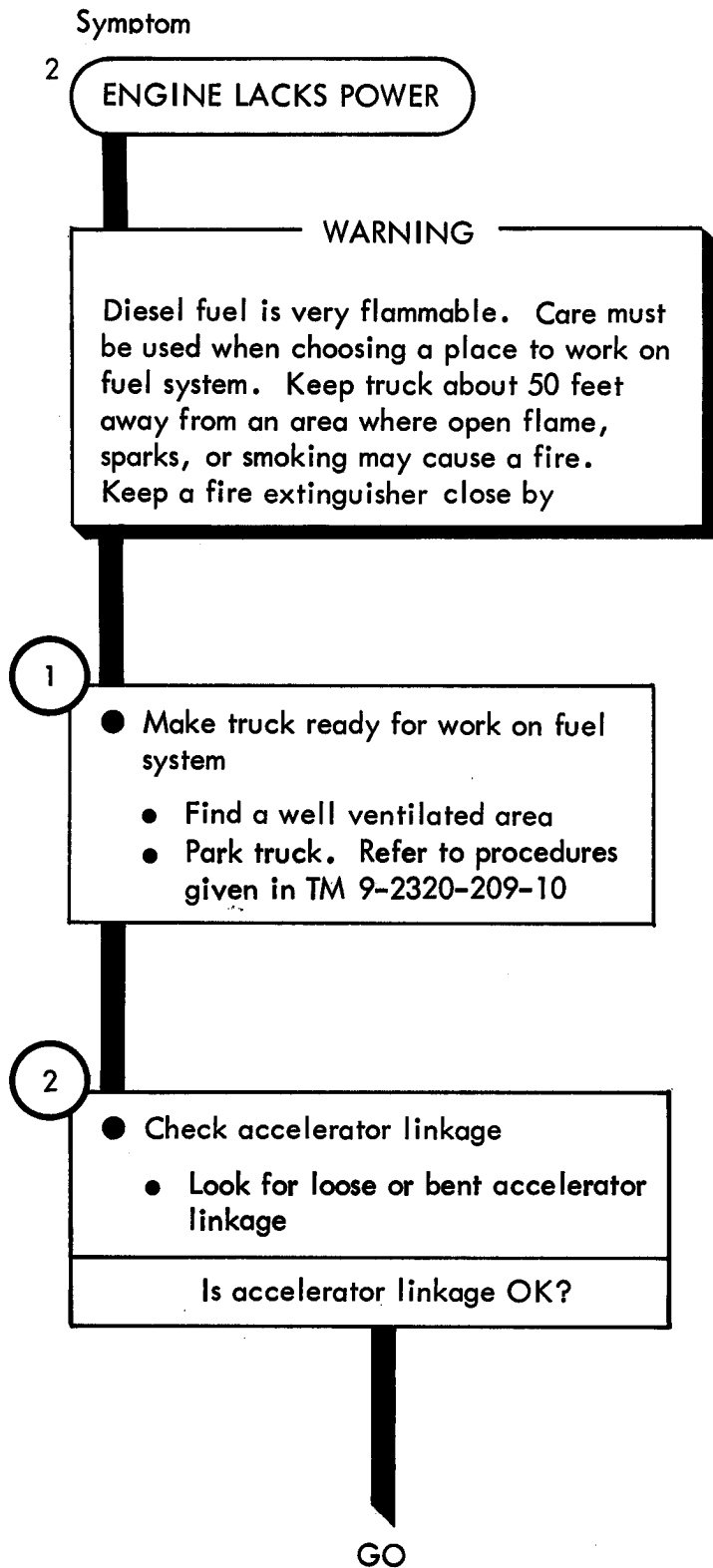
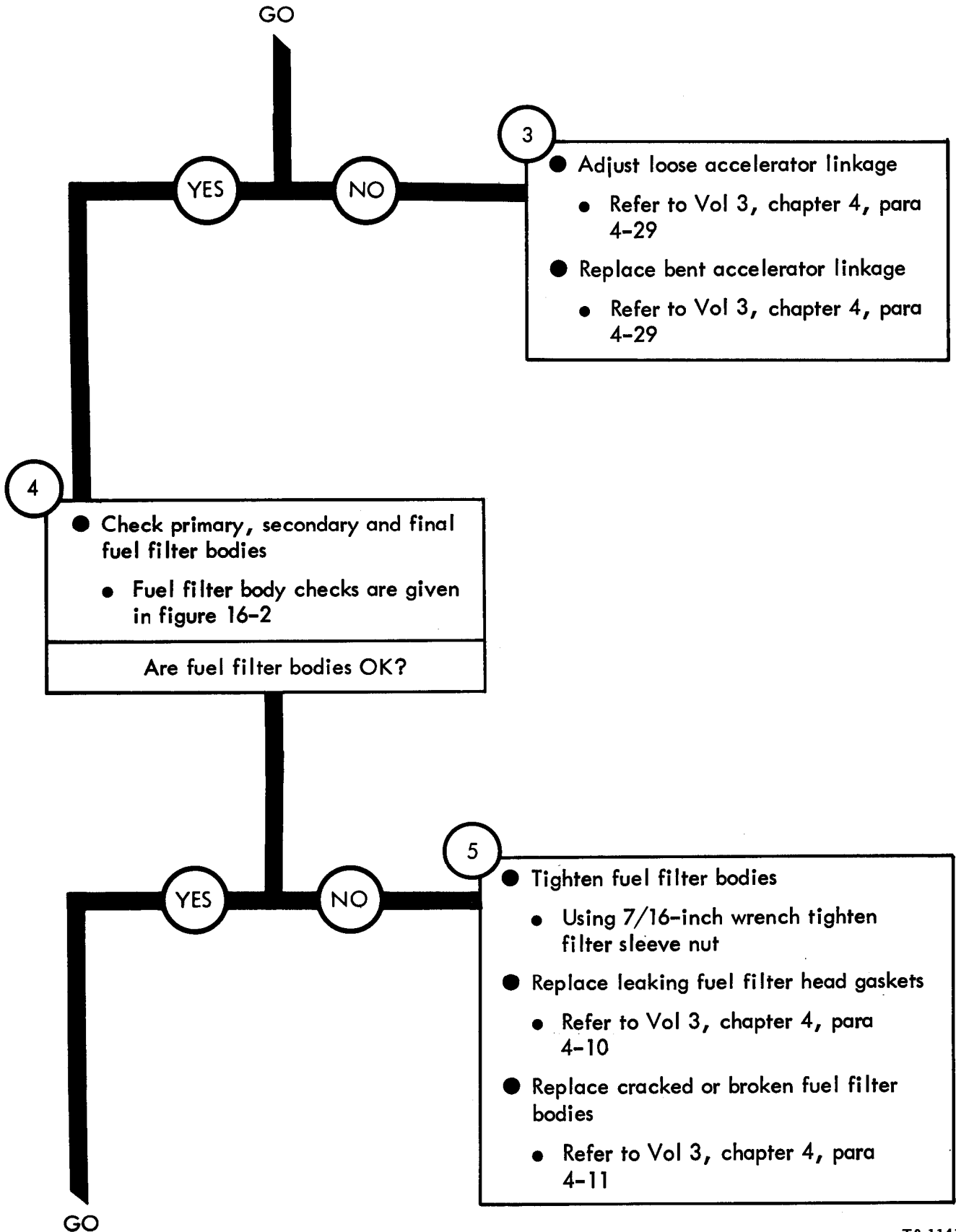
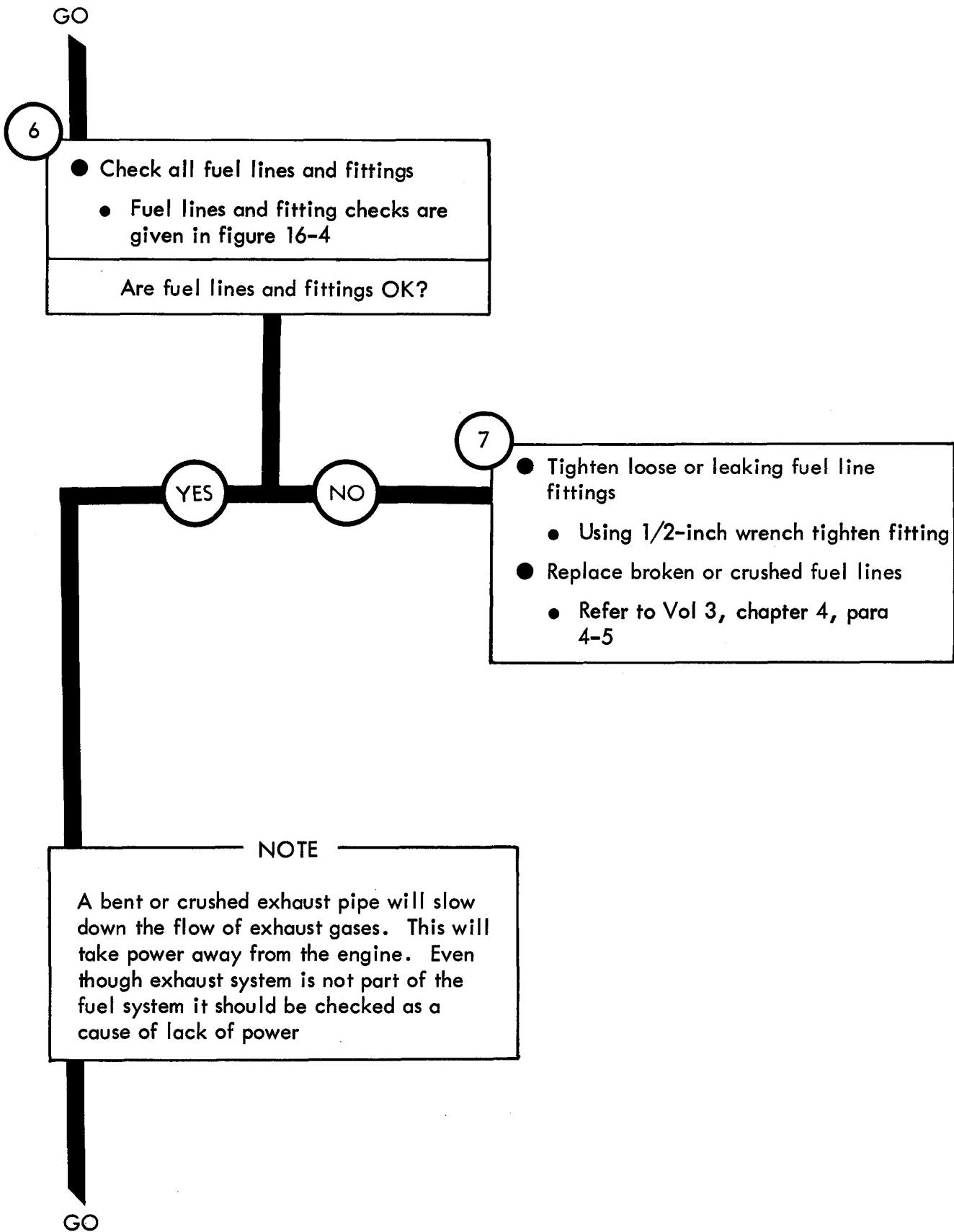

Figure 13-2 (Sheet 1 of 5)



TA 114109

Figure 13-2 (Sheet 2 of 5)



NOTE

A bent or crushed exhaust pipe will slow down the flow of exhaust gases. This will take power away from the engine. Even though exhaust system is not part of the fuel system it should be checked as a cause of lack of power

Figure 13-2 (Sheet 3 of 5)

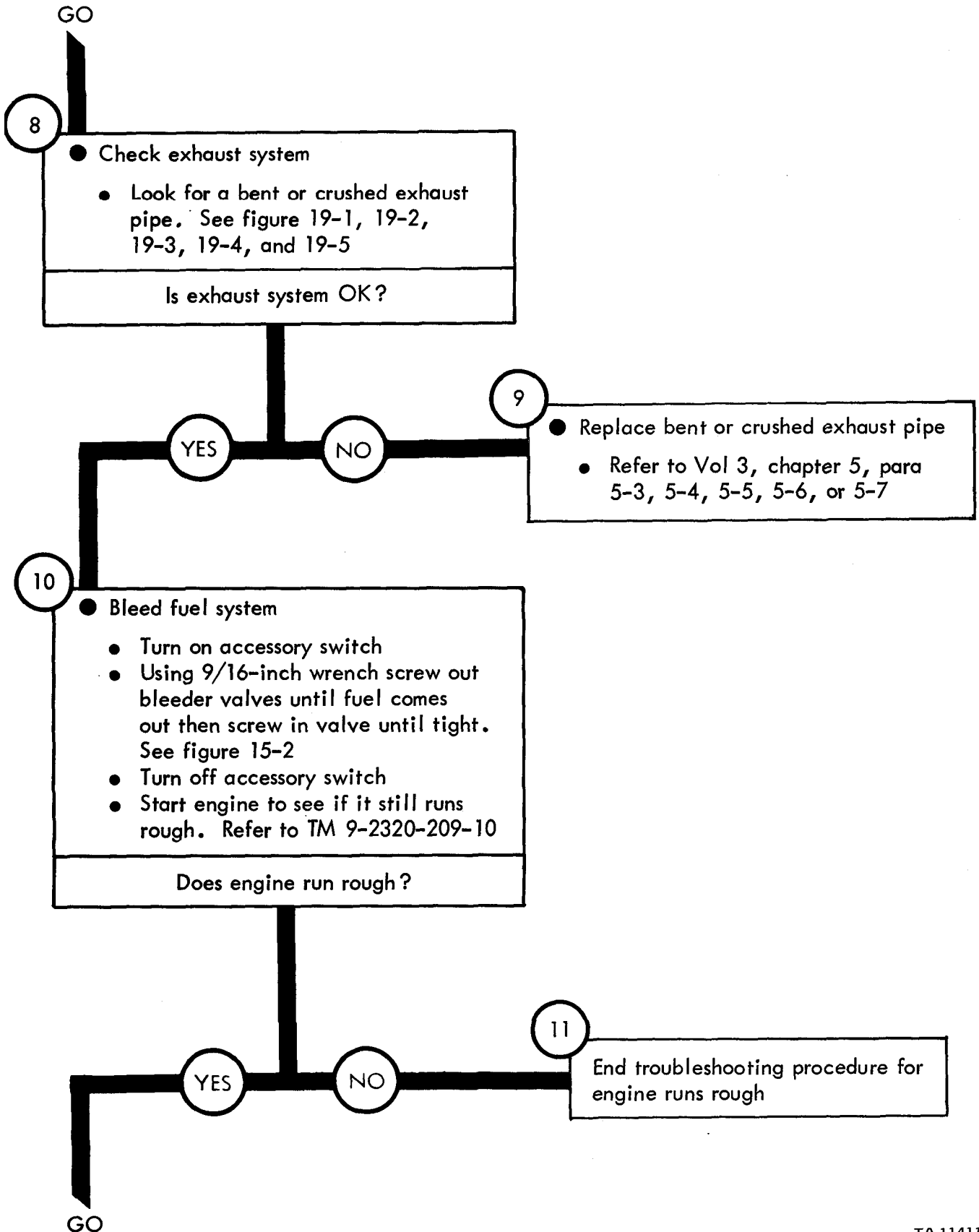

Figure 13-2 (Sheet 4 of 5)

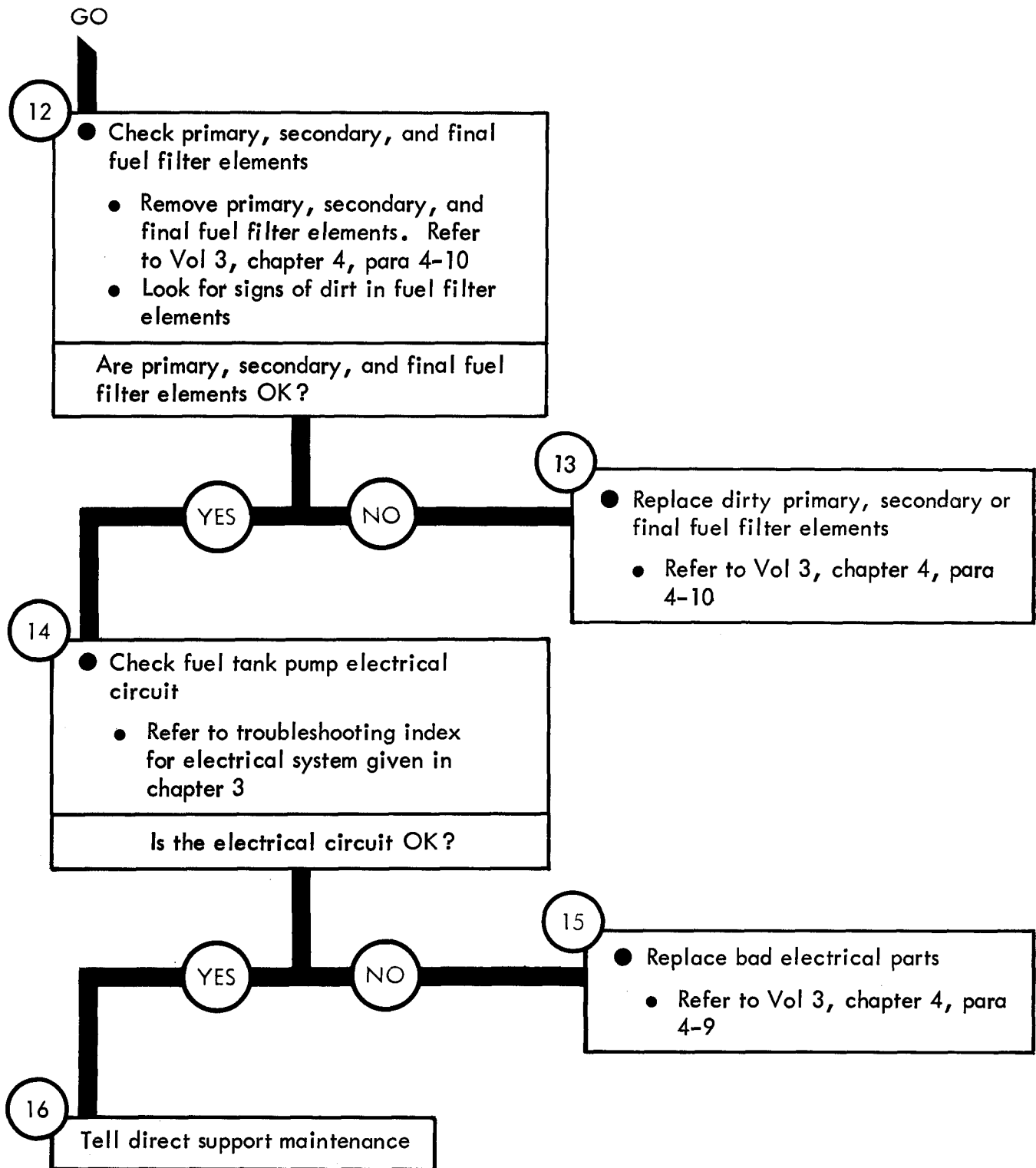

Figure 13-2 (Sheet 5 of 5)

Symptom

3

ENGINE RUNS ROUGH

WARNING

Diesel fuel is very flammable. Care must be used when choosing a place to work on fuel system. Keep truck about 50 feet away from an area where open flame, sparks, or smoking may cause a fire. Keep a fire extinguisher close by

1

- Make truck ready for work on fuel system
 - Find a well ventilated area
 - Park truck. Refer to TM 9-2320-209-10

2

- Check primary, secondary and final fuel filter bodies
 - Fuel filter body checks are given in figure 16-2

Are fuel filter bodies OK?

Figure 13-3 (Sheet 1 of 5)

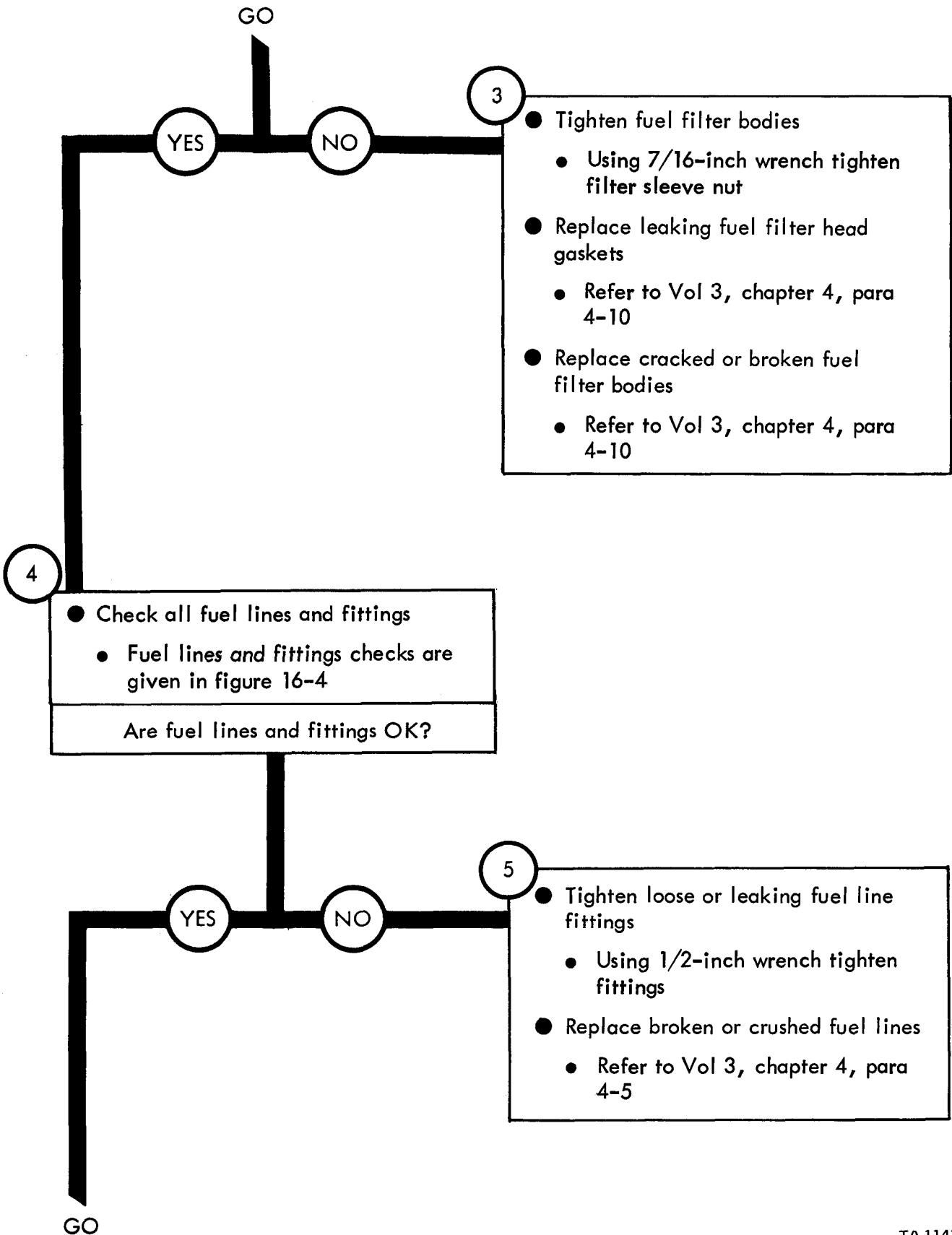

Figure 13-3 (Sheet 2 of 5)

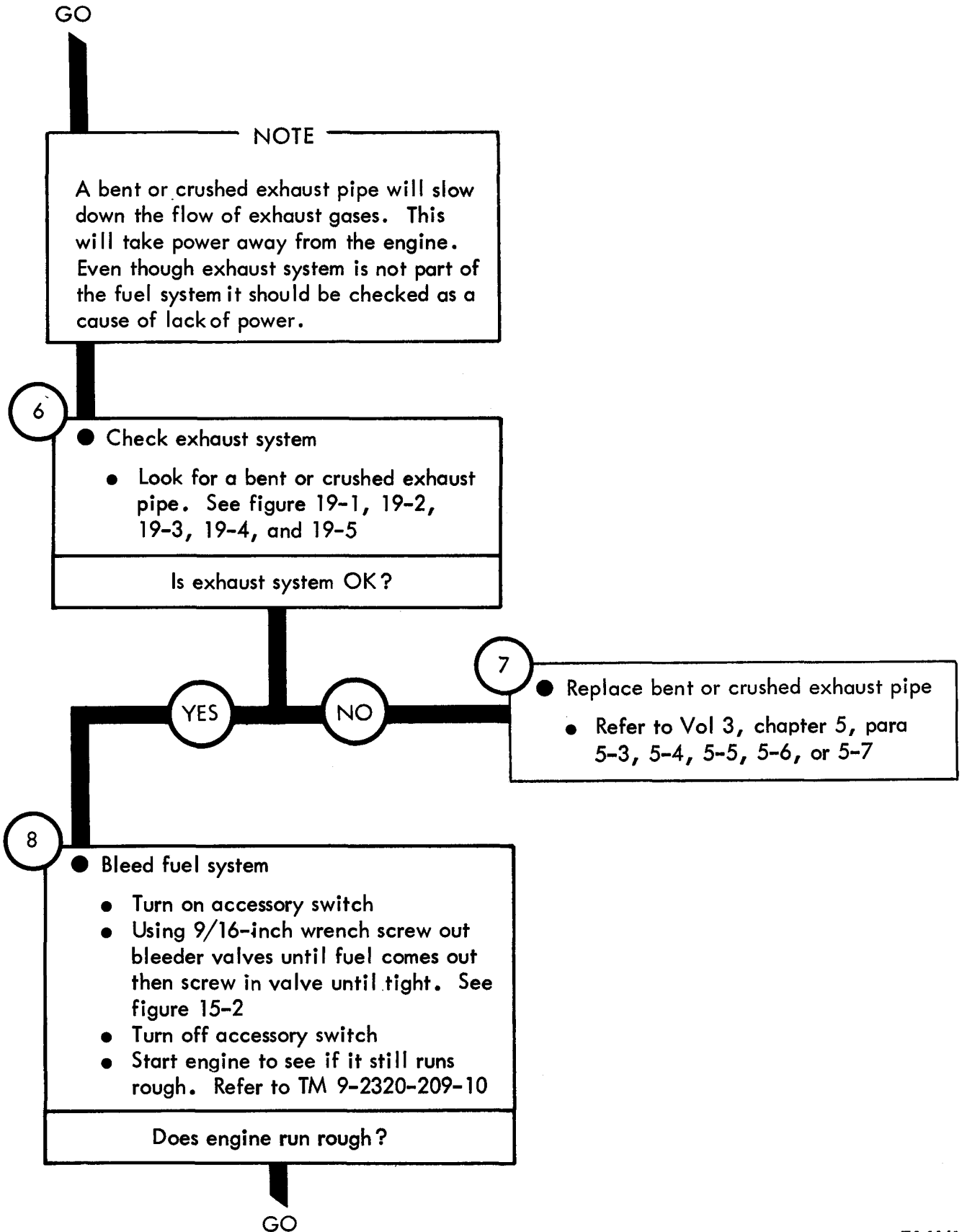
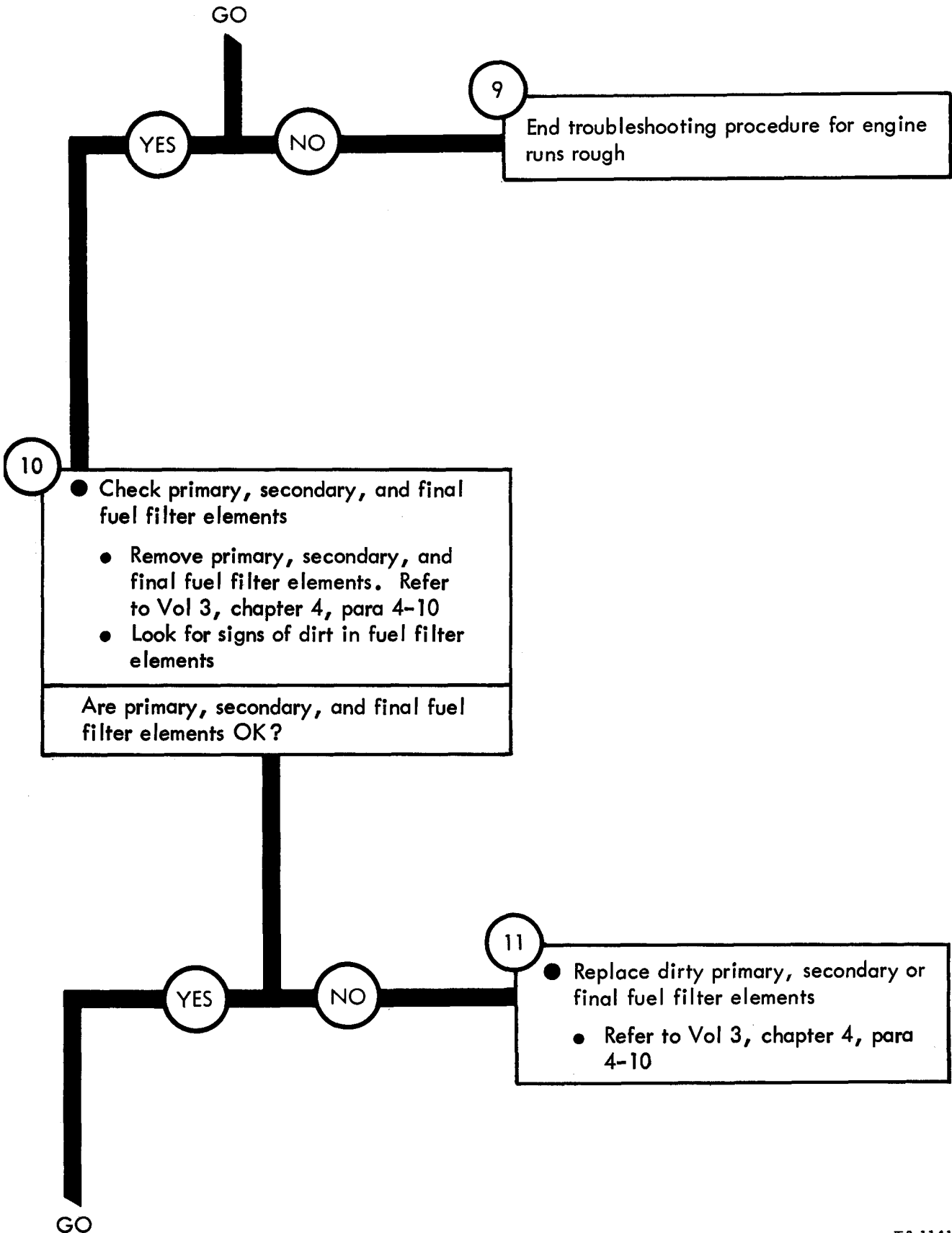
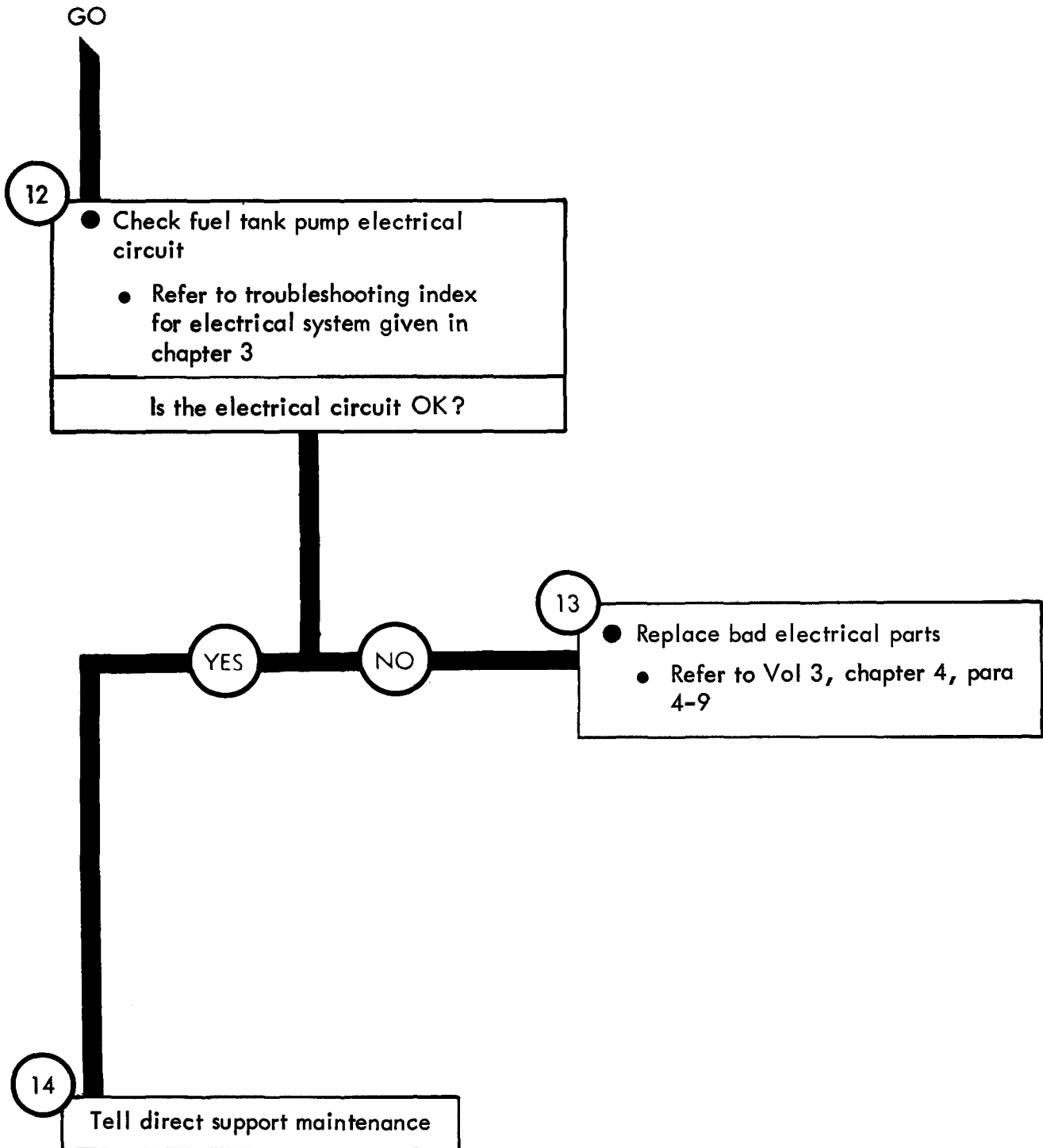
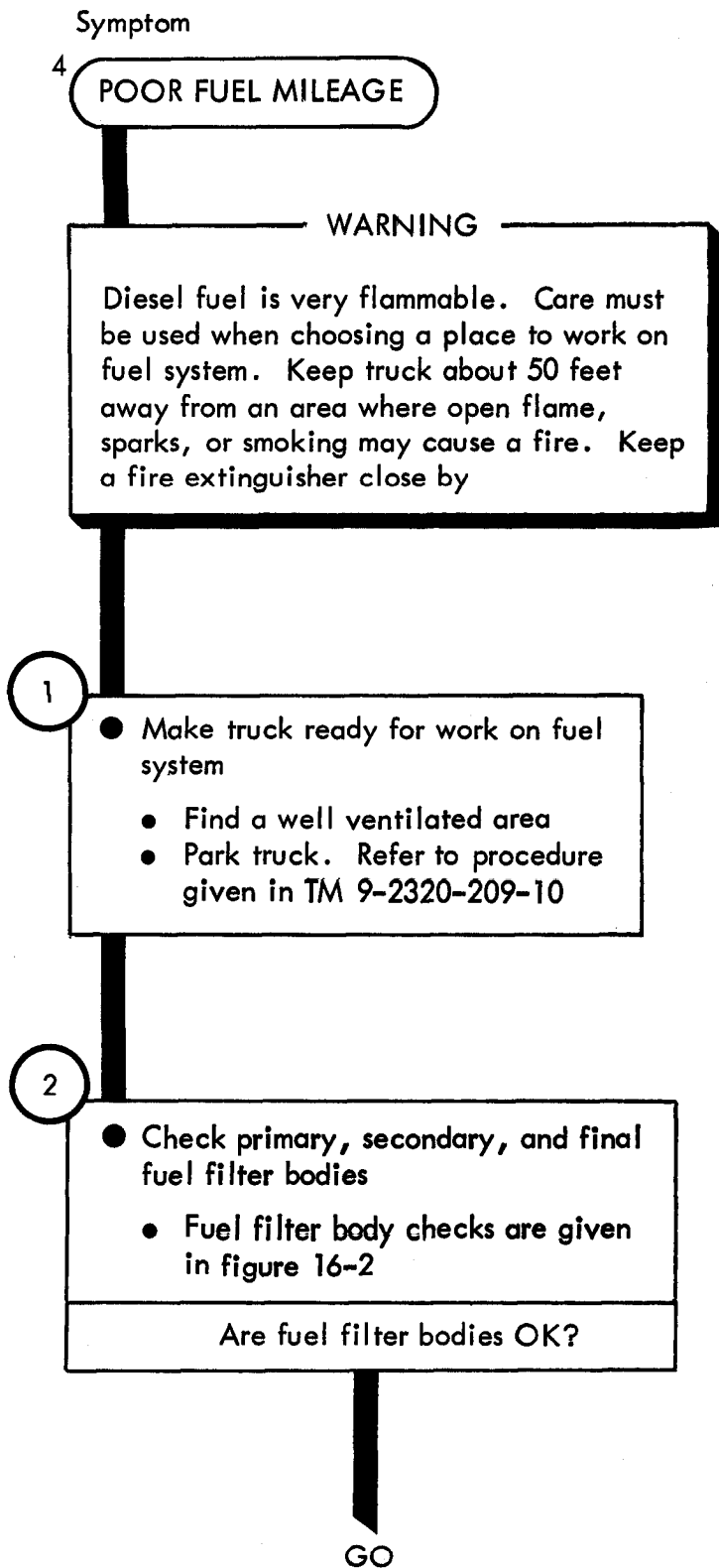
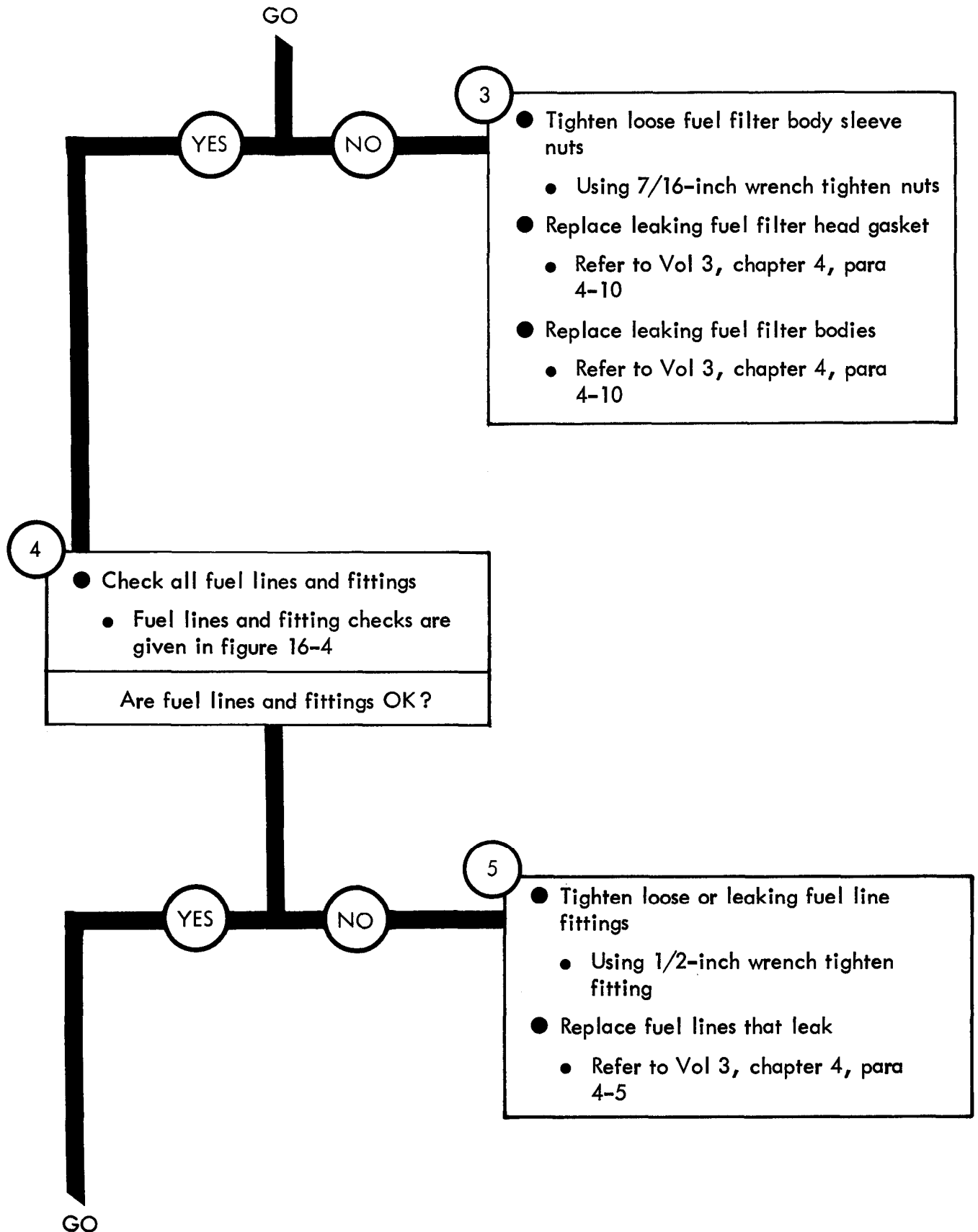

Figure 13-3 (Sheet 3 of 5)









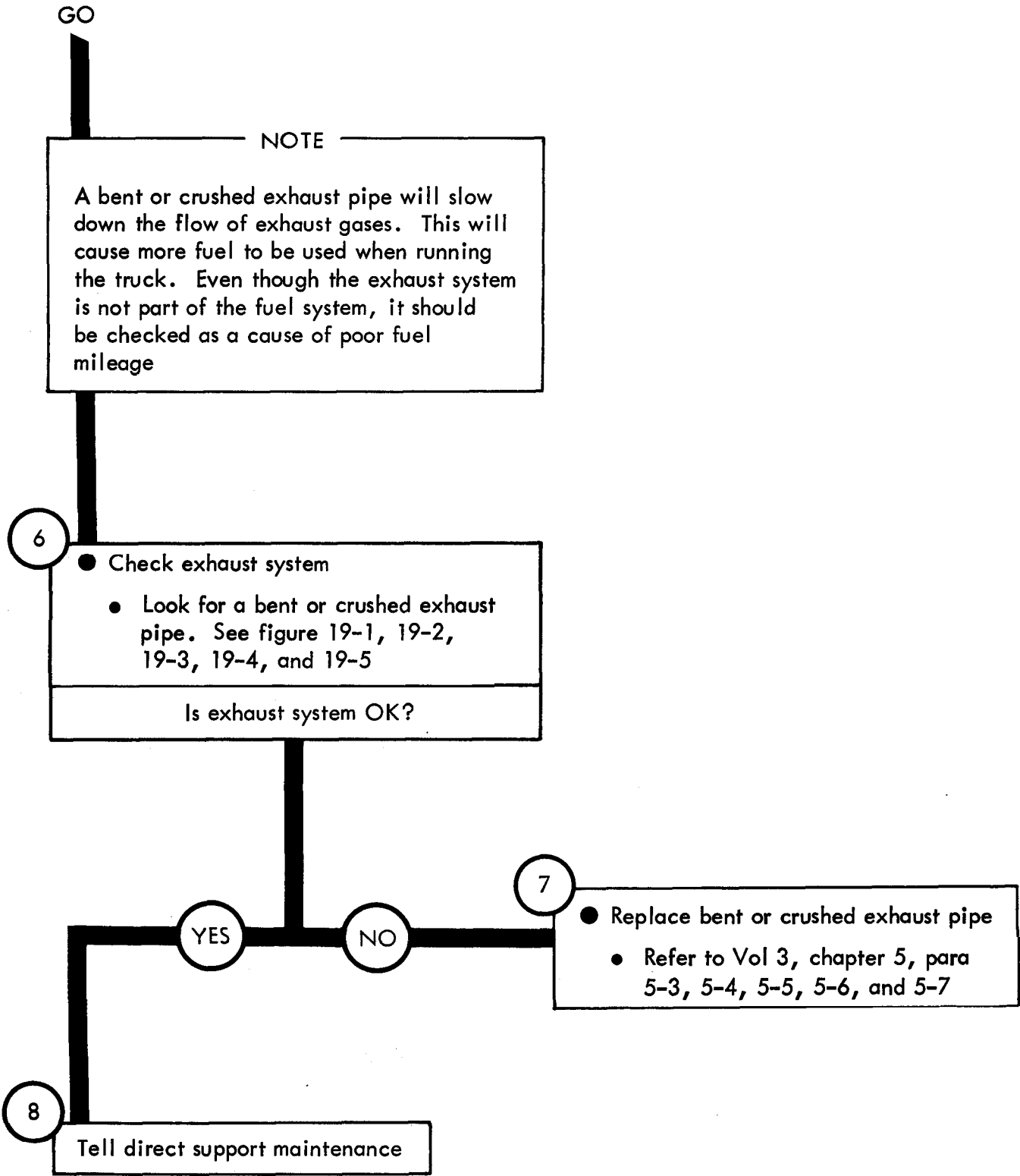

Symptom

5 ENGINE DOES NOT SLOW DOWN WHEN ACCELERATOR PEDAL IS LET GO

WARNING

Diesel fuel is very flammable. Care must be used when choosing a place to work on fuel system. Keep truck about 50 feet away from an area where open flame, sparks, or smoking may cause a fire. Keep a fire extinguisher close by

- 1
- Make truck ready for work on fuel system
 - Find a well ventilated area
 - Park truck. Refer to TM 9-2320-209-10

- 2
- Check accelerator return spring
 - See if both ends of return spring are attached
 - See if return spring is broken

Is accelerator return spring OK?

GO

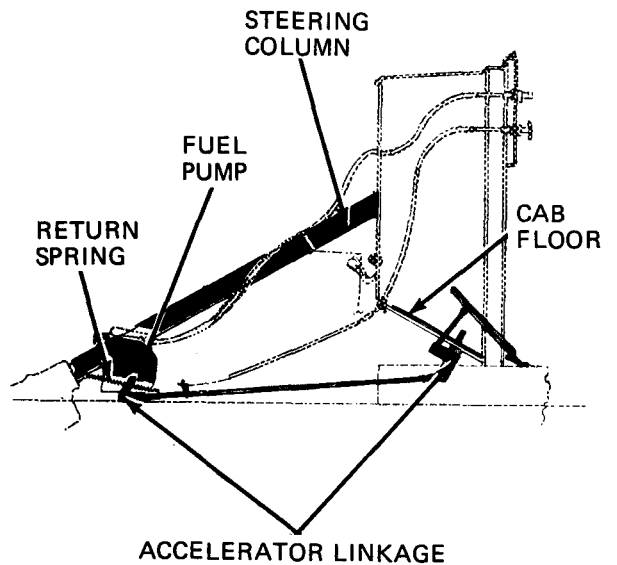

TA 114121

Figure 13-5 (Sheet 1 of 3)

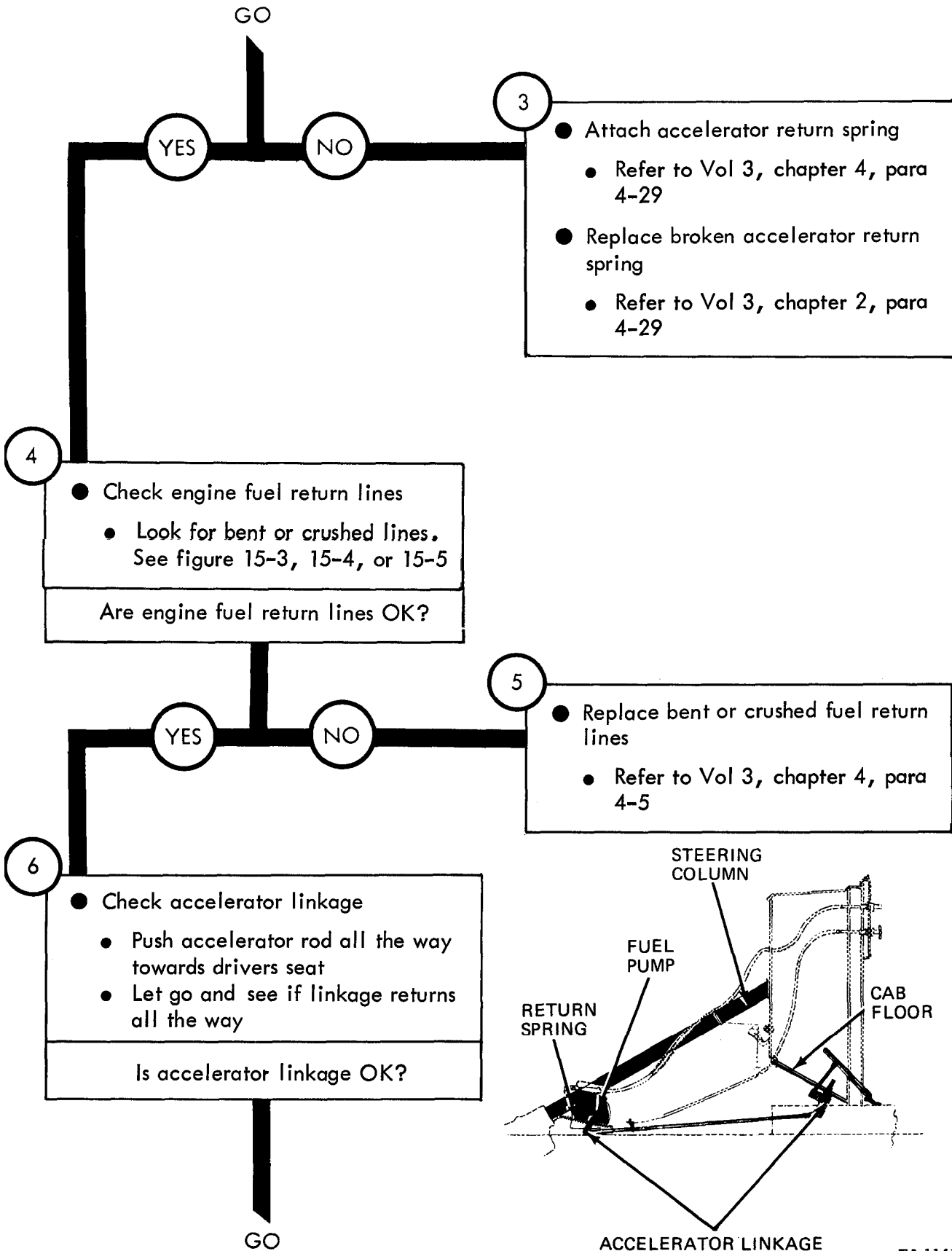

TA 114122

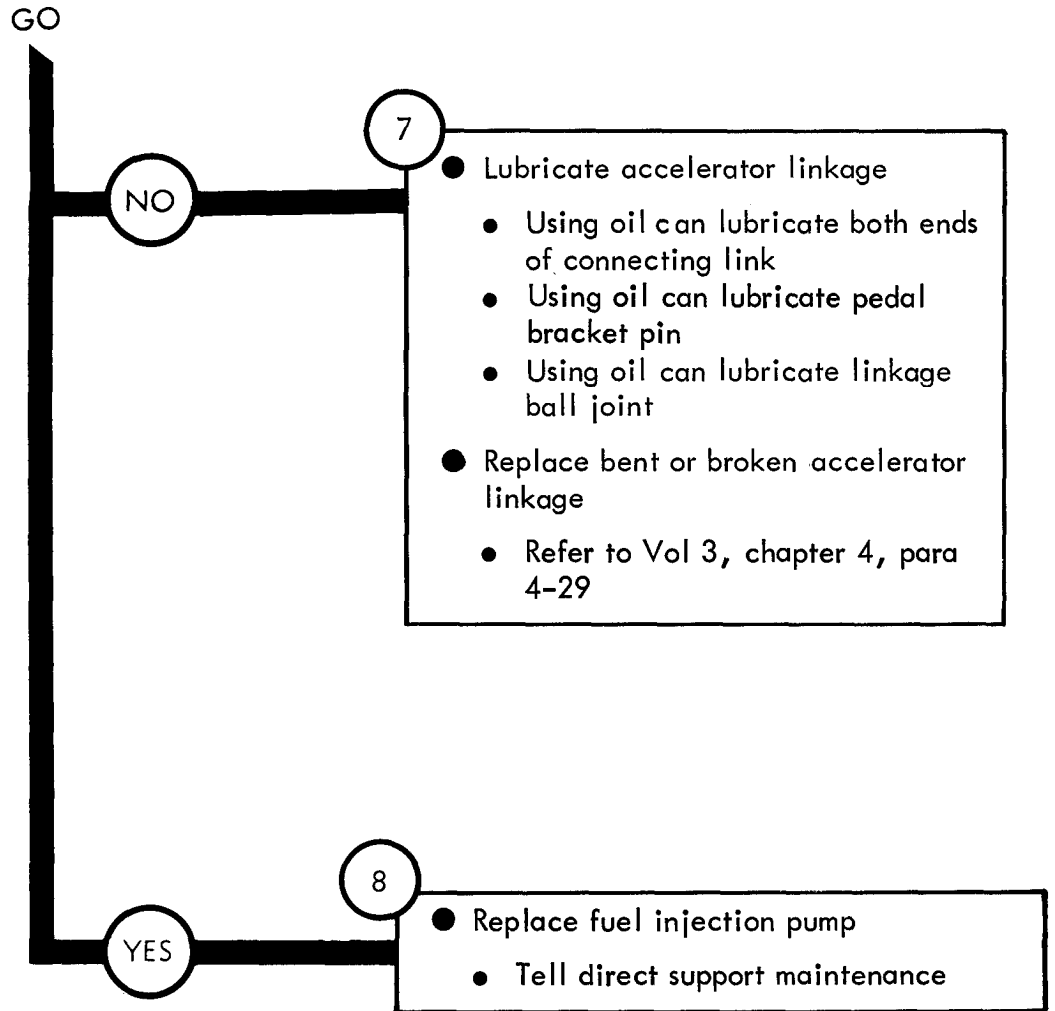

Symptom

6

ENGINE RUNS AFTER BEING SHUT OFF

WARNING

Diesel fuel is very flammable. Care must be used when choosing a place to work on fuel system. Keep truck about 50 feet away from an area where open flame, sparks, or smoking may cause a fire. Keep a fire extinguisher close by

1

- Make truck ready for work on fuel system
 - Find a well ventilated area
 - Park truck. Refer to procedures given in TM 9-2320-209-10

2

- Check engine fuel return lines
 - Look for bent or crushed lines. See figure 15-3, 15-4, or 15-5

Are engine fuel return lines OK?

GO

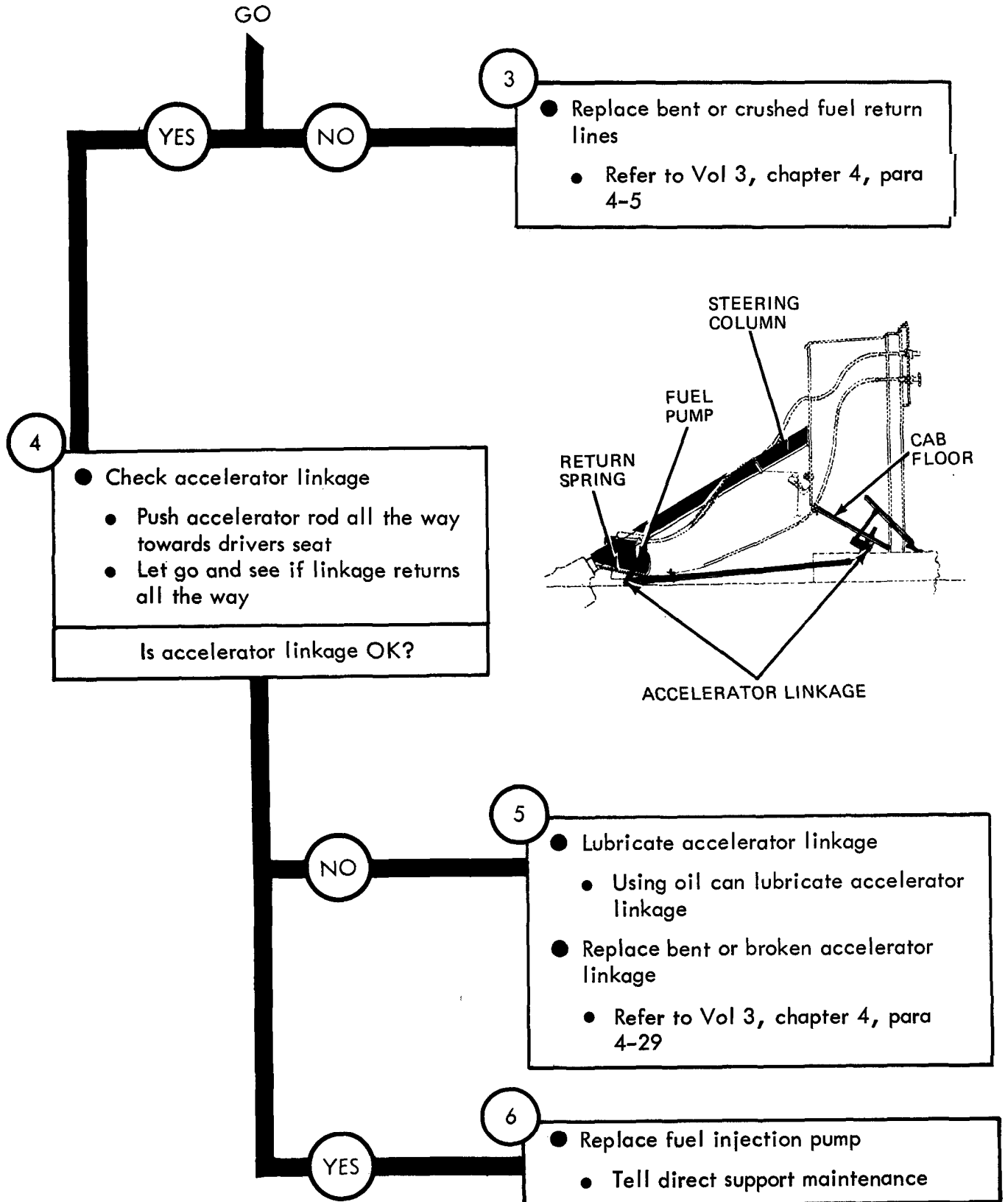

TA 114125

Figure 13-6(Sheet 2 of 2)

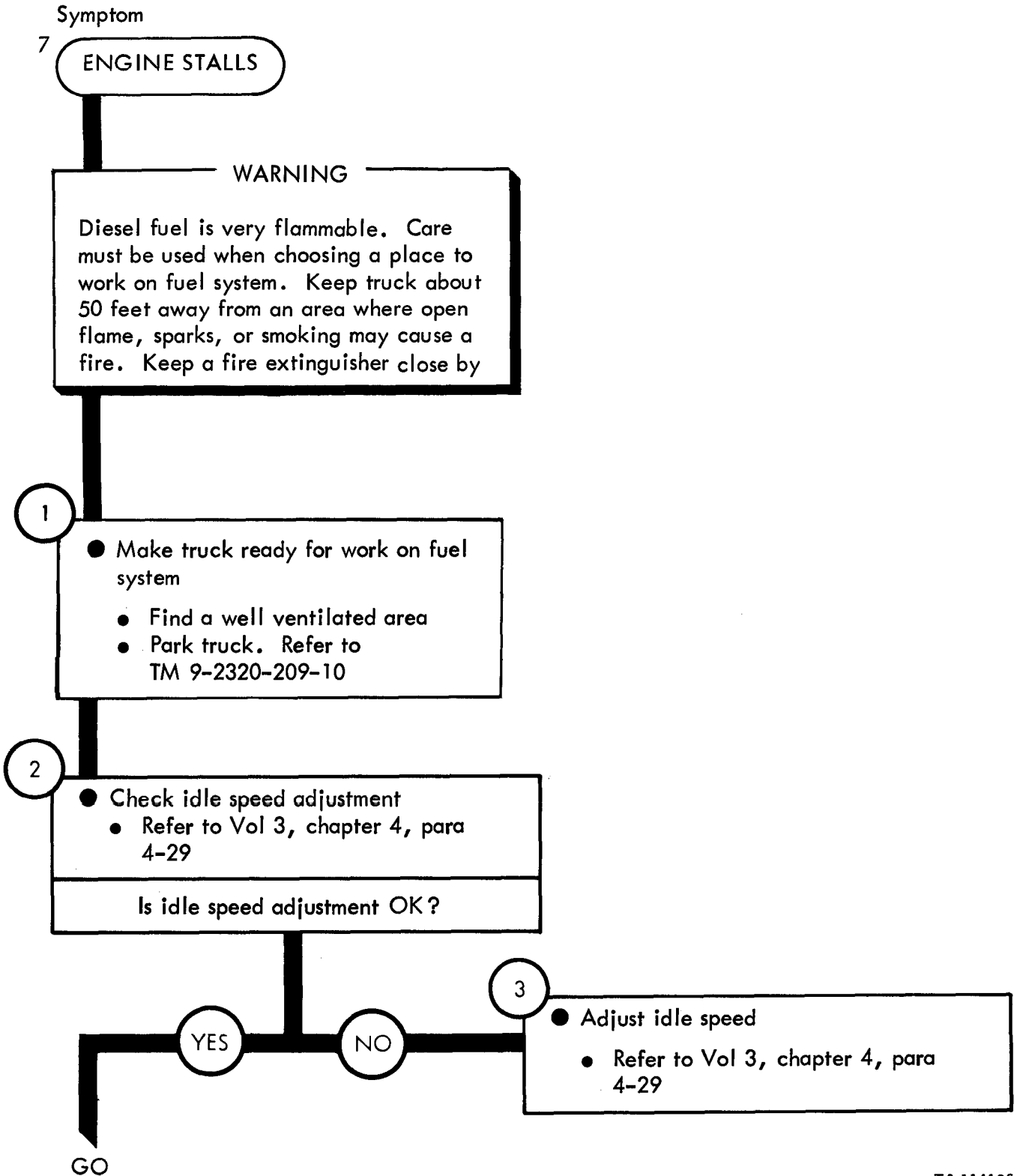

TA 114126

Figure 13-7 (Sheet 1 of 2)

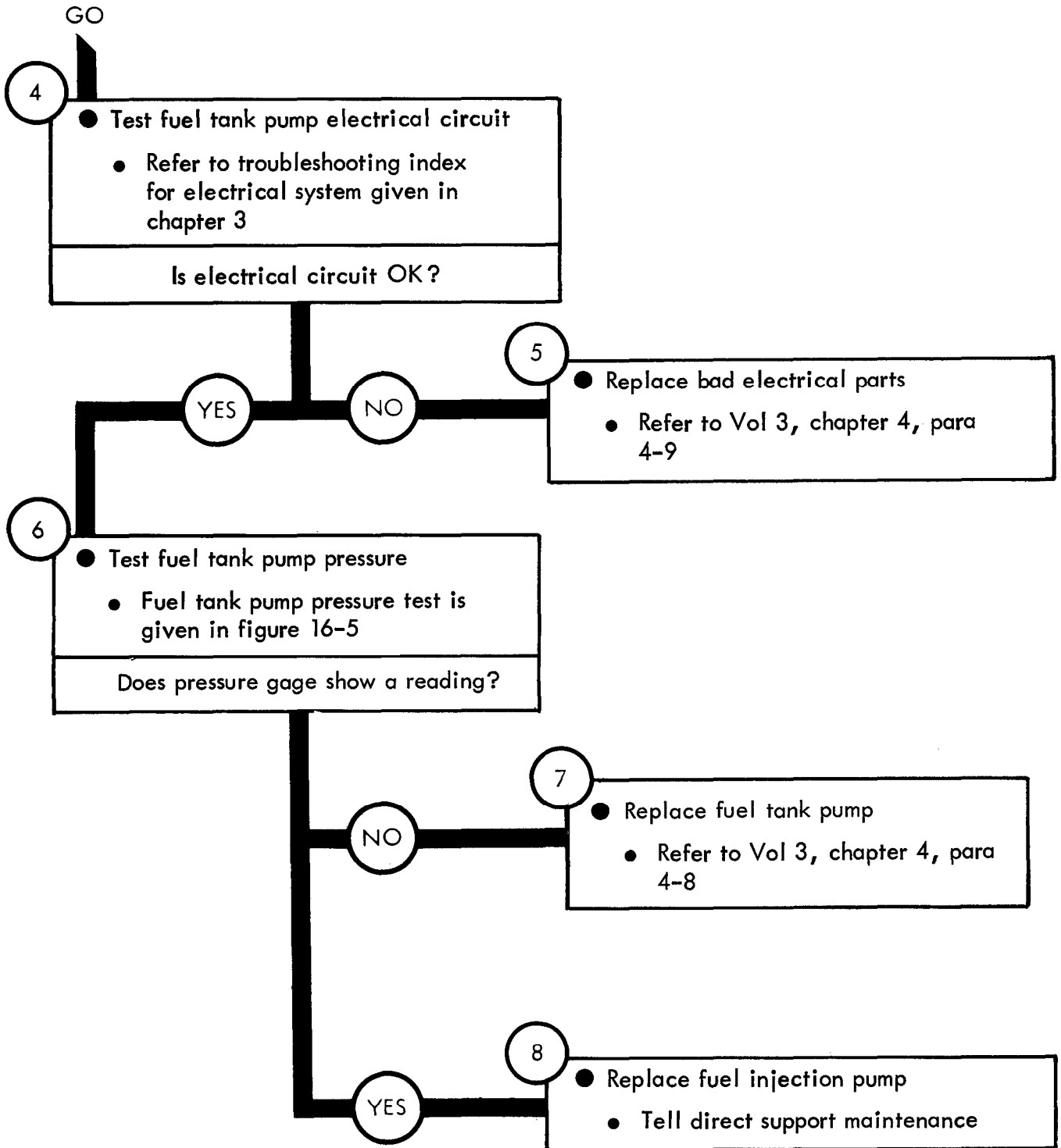

Symptom

8

HARD STARTING

WARNING

Diesel fuel is very flammable. Care must be used when choosing a place to work on fuel system. Keep truck about 50 feet away from an area where open flame, sparks, or smoking may cause a fire. Keep a fire extinguisher close by

1

- Make truck ready for work on fuel system
 - Find a well ventilated area
 - Park truck. Refer to TM 9-2320-209-10

GO

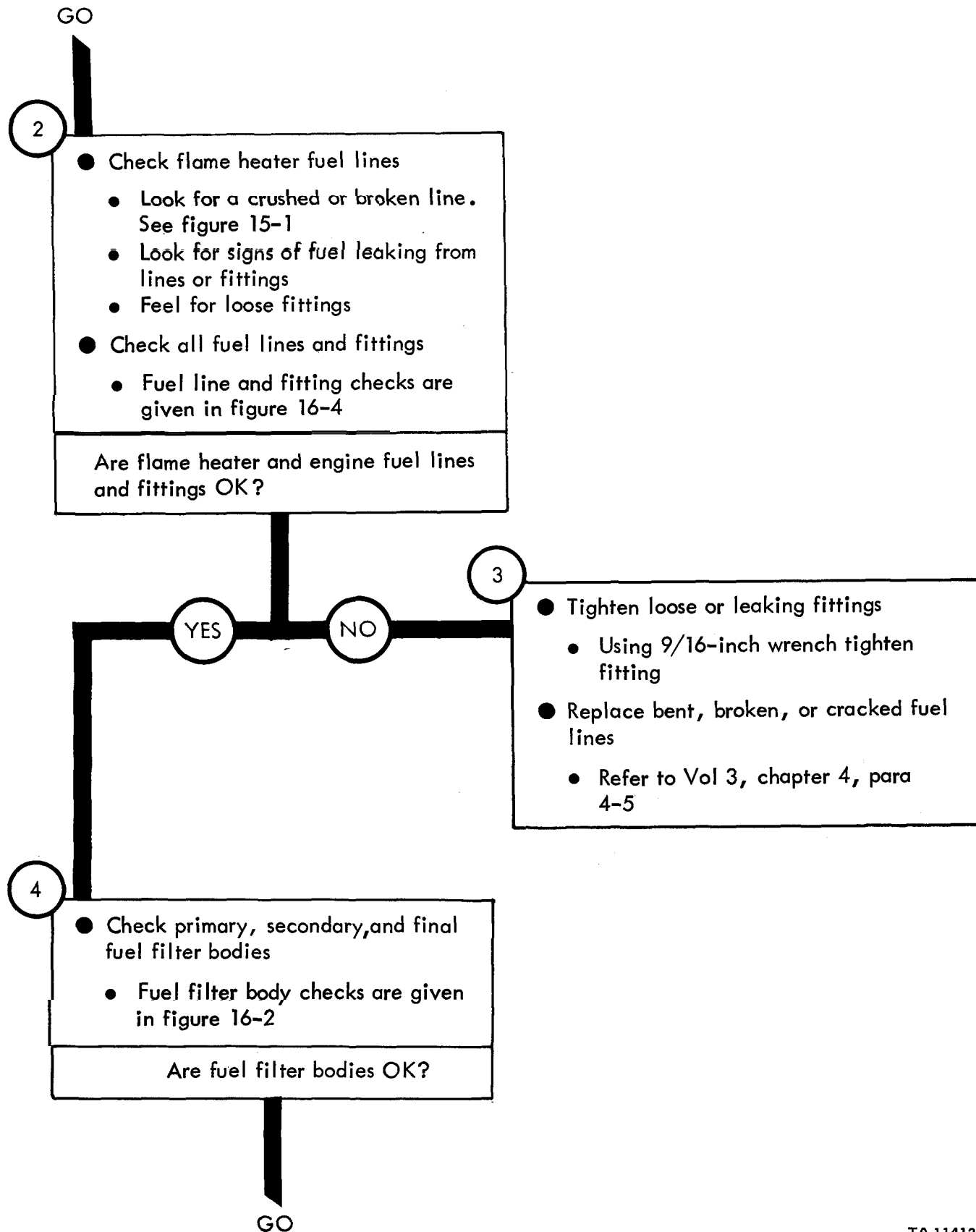

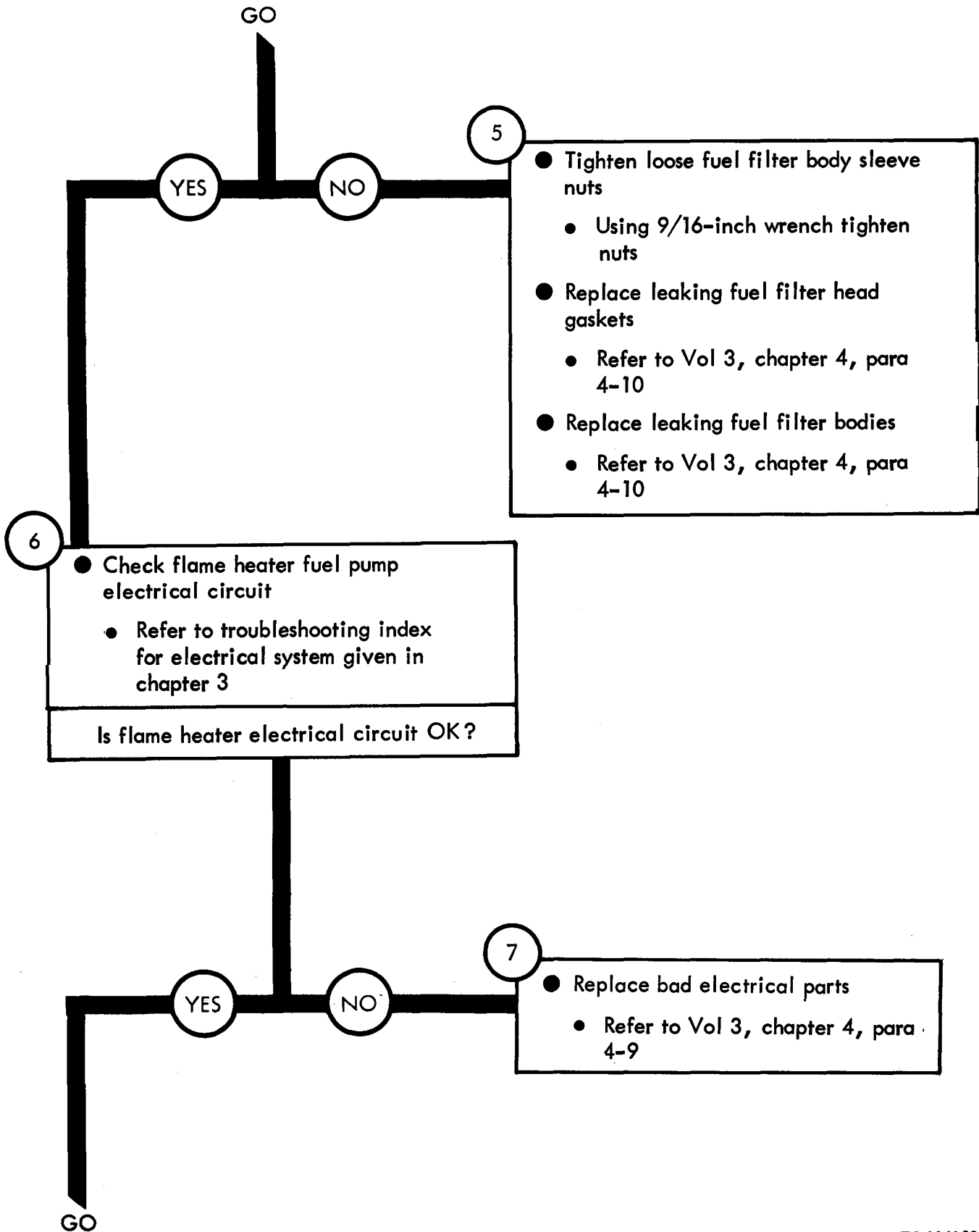

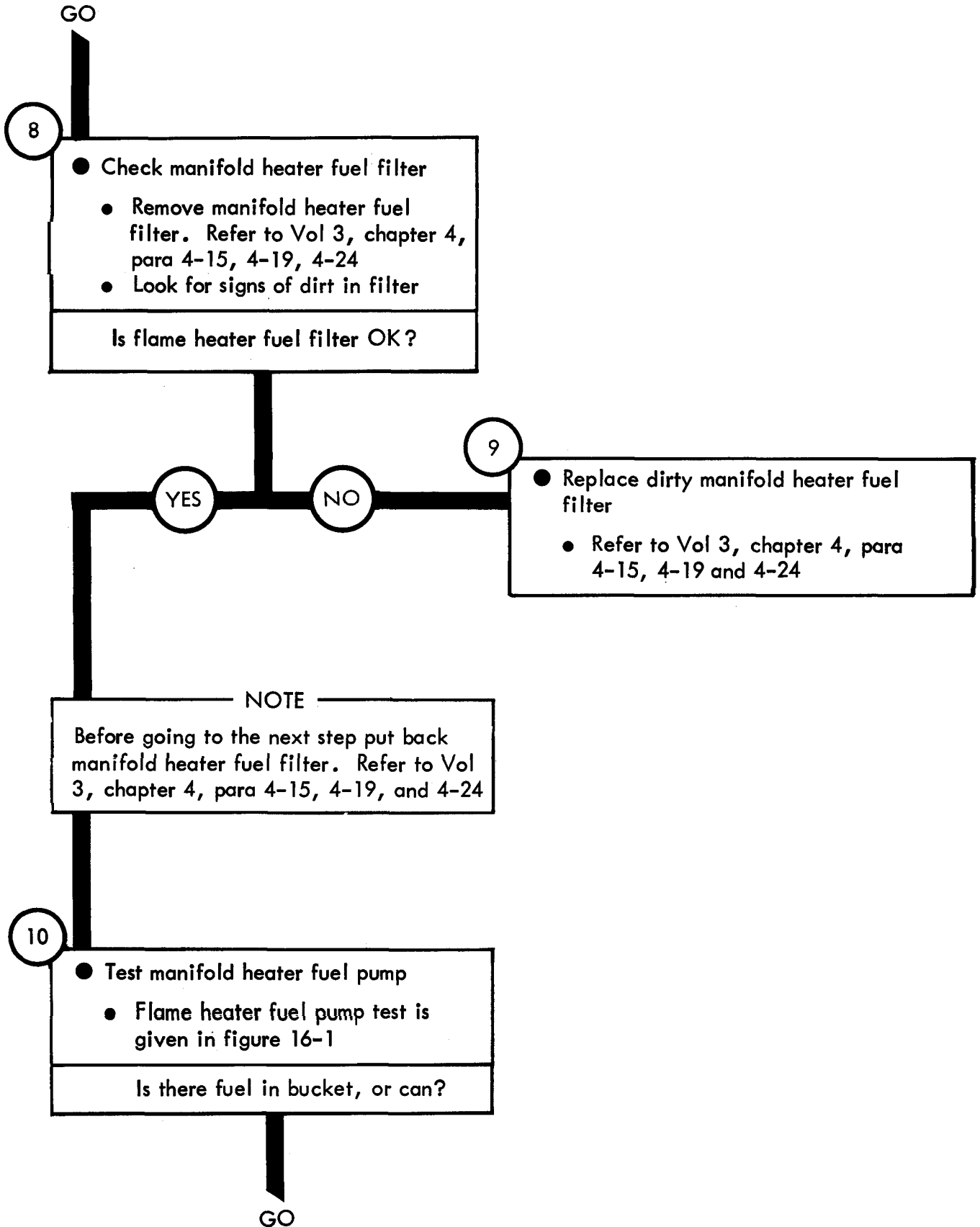

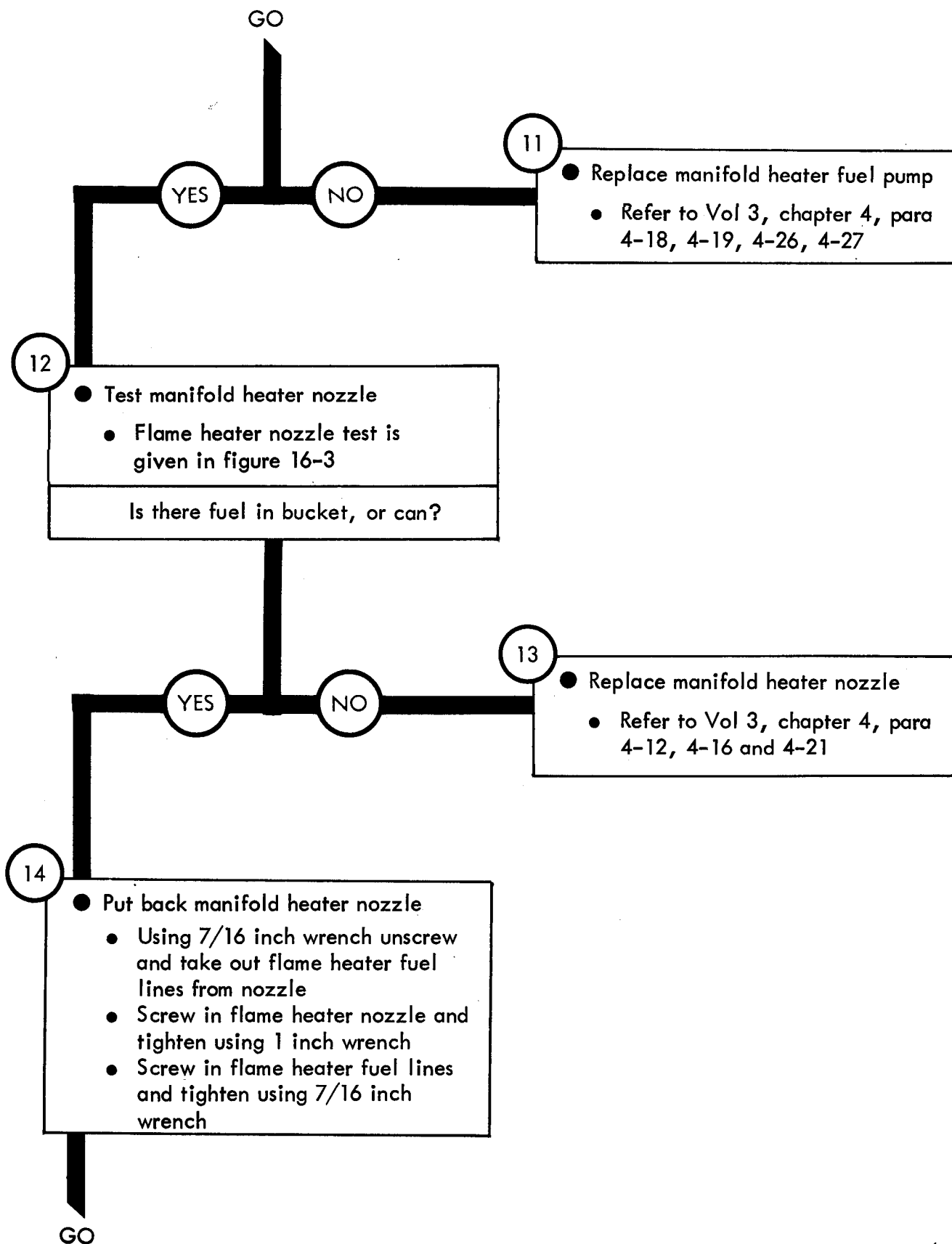

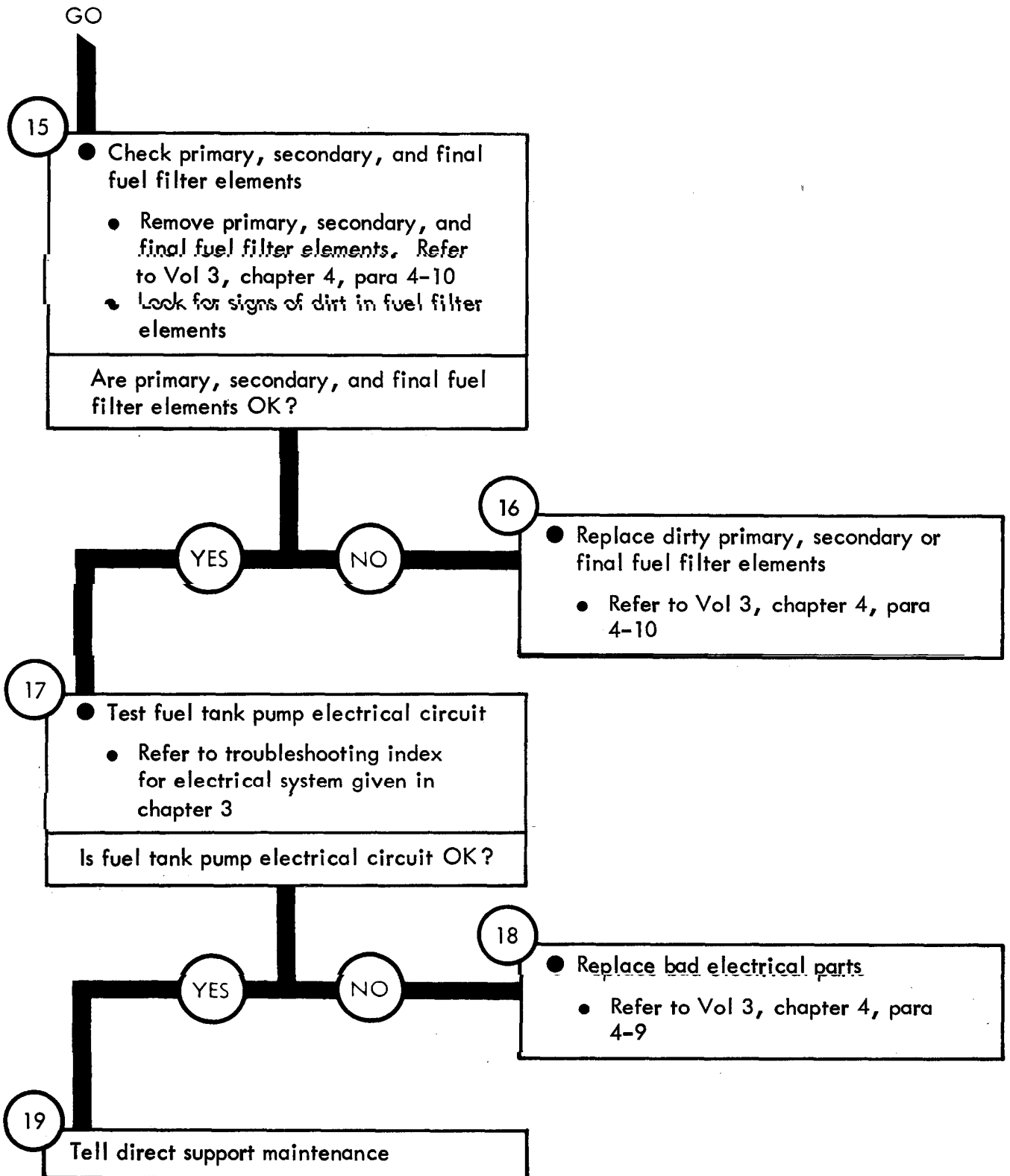

CHAPTER 14

FUEL SYSTEM TROUBLESHOOTING SUMMARY

14-1. GENERAL. This chapter gives a summary of troubleshooting procedures given in chapter 13 for the fuel system.

14-2. PROCEDURES. The summary in this chapter covers all fault symptoms found in the detailed troubleshooting procedures. Chapter 7 outlines a sample troubleshooting procedure. The summary procedures are based on the "what-to-do" portions of the detailed procedures and do not include the "how-to-do-it" instructions. Warning, cautions, and notes are given where needed.

FUEL SYSTEM TROUBLESHOOTING SUMMARY

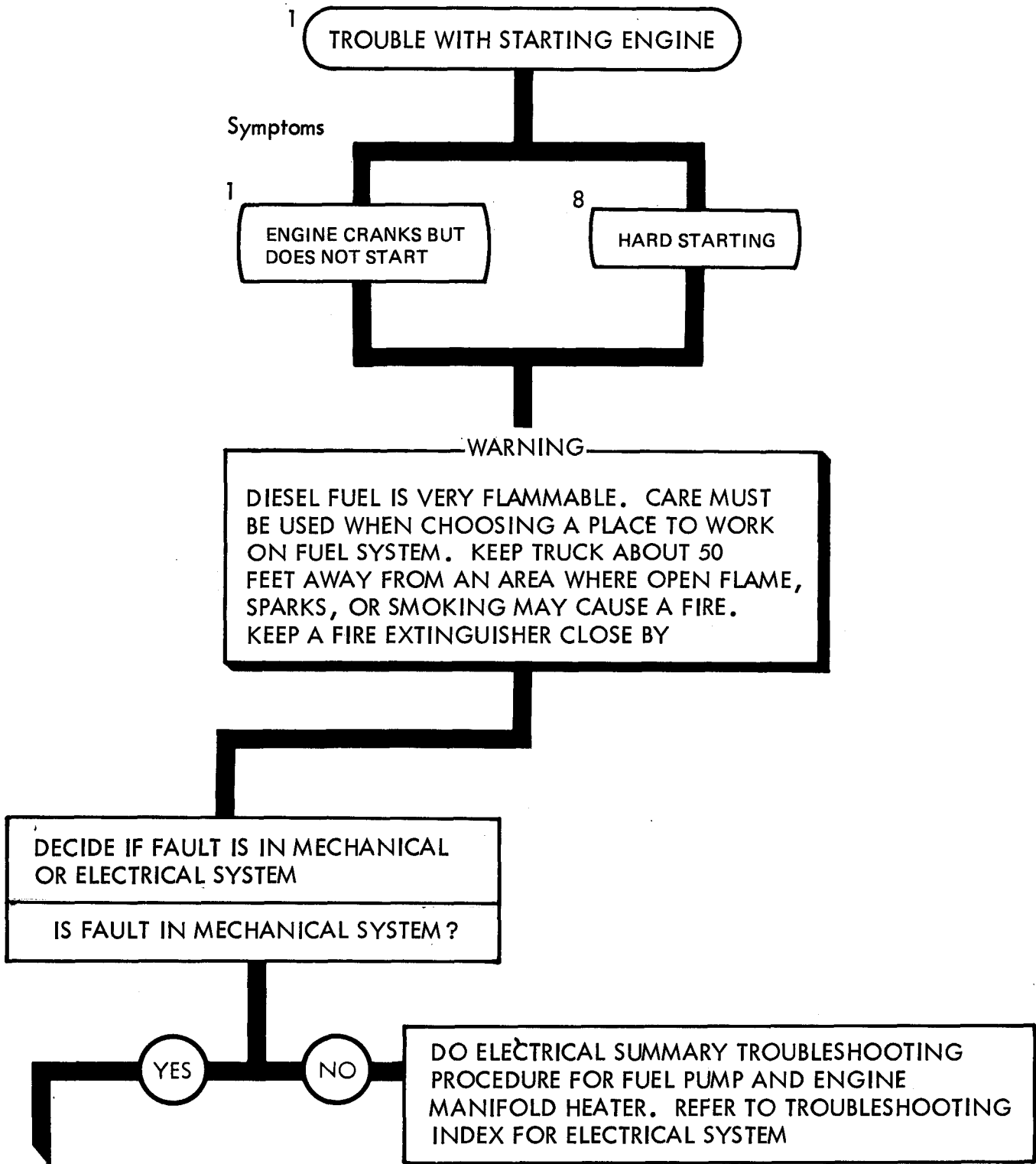
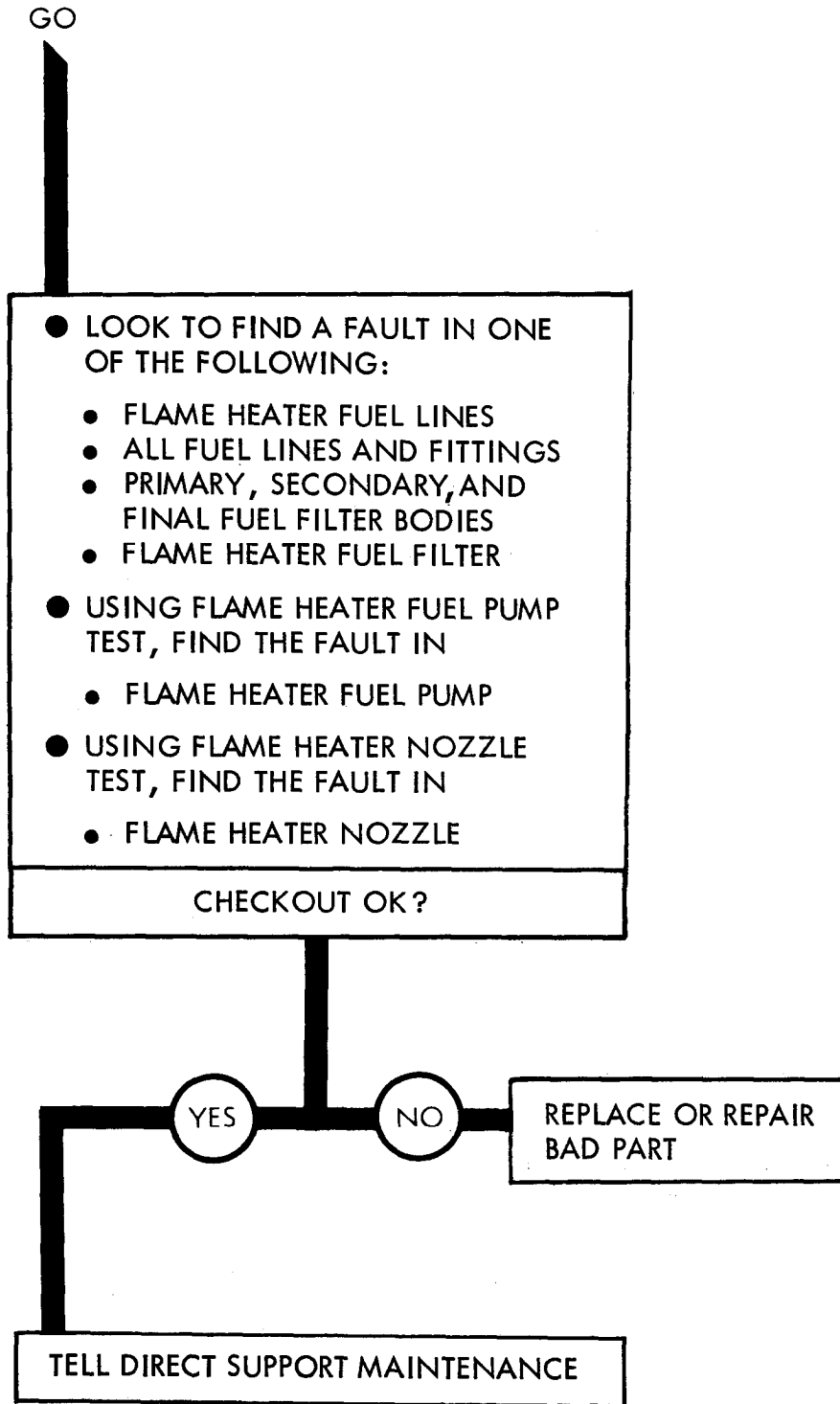
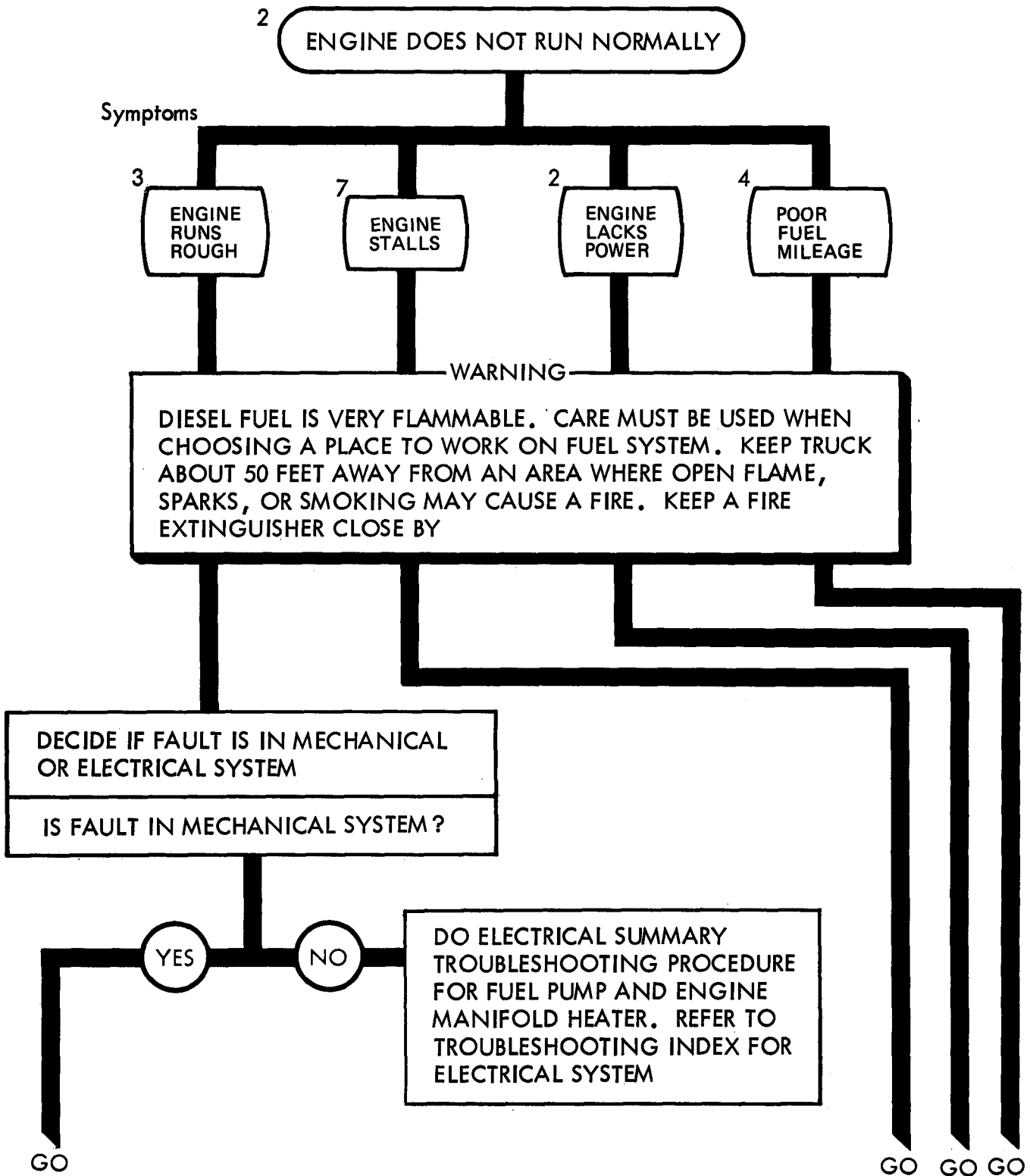

Figure 14-1 (Sheet 1 of 2)



NOTE: FOR DETAILED TROUBLESHOOTING PROCEDURES, SEE SYMPTOM INDEX



TA 114136

Figure 14-2 (Sheet 1 of 5)

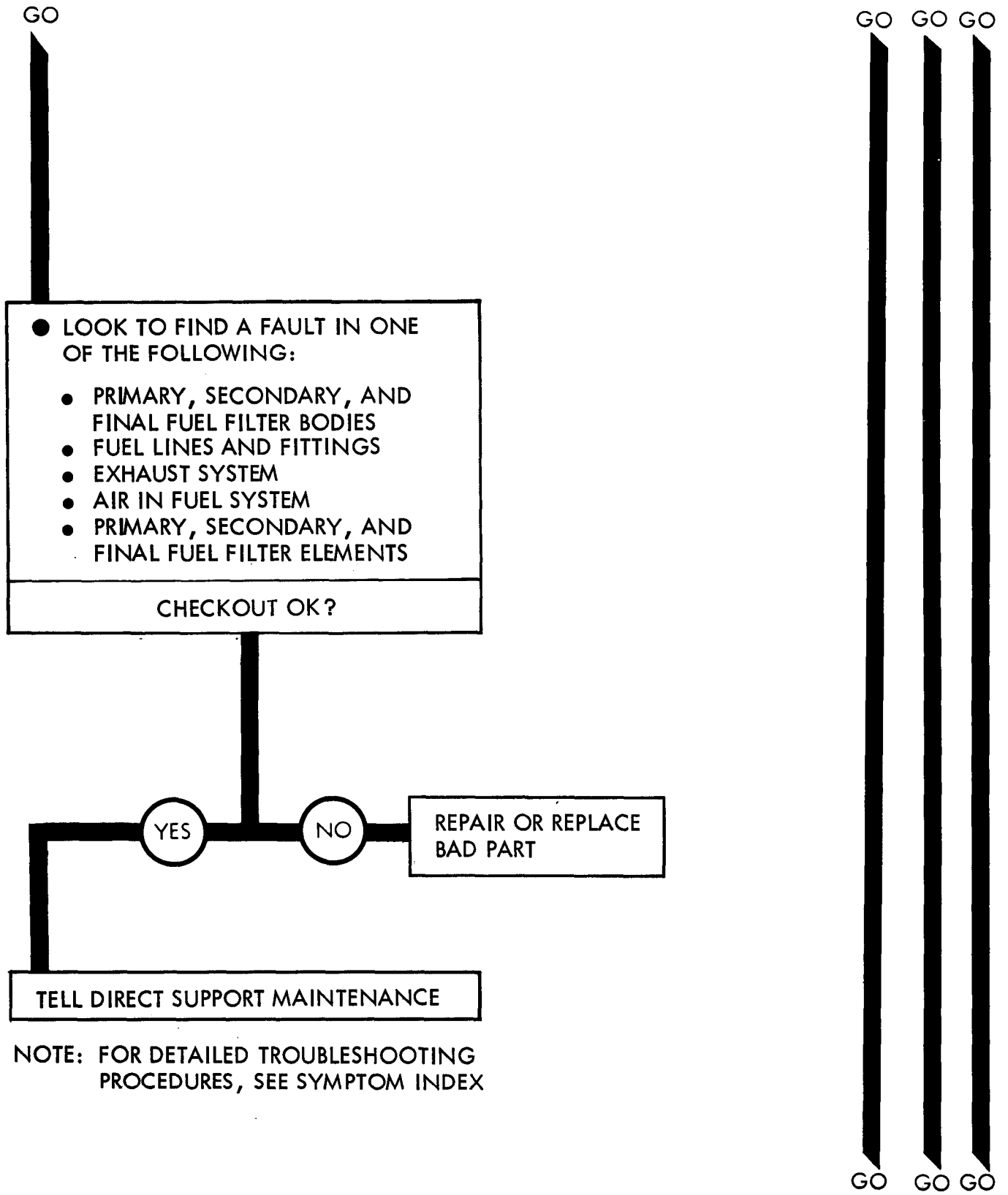
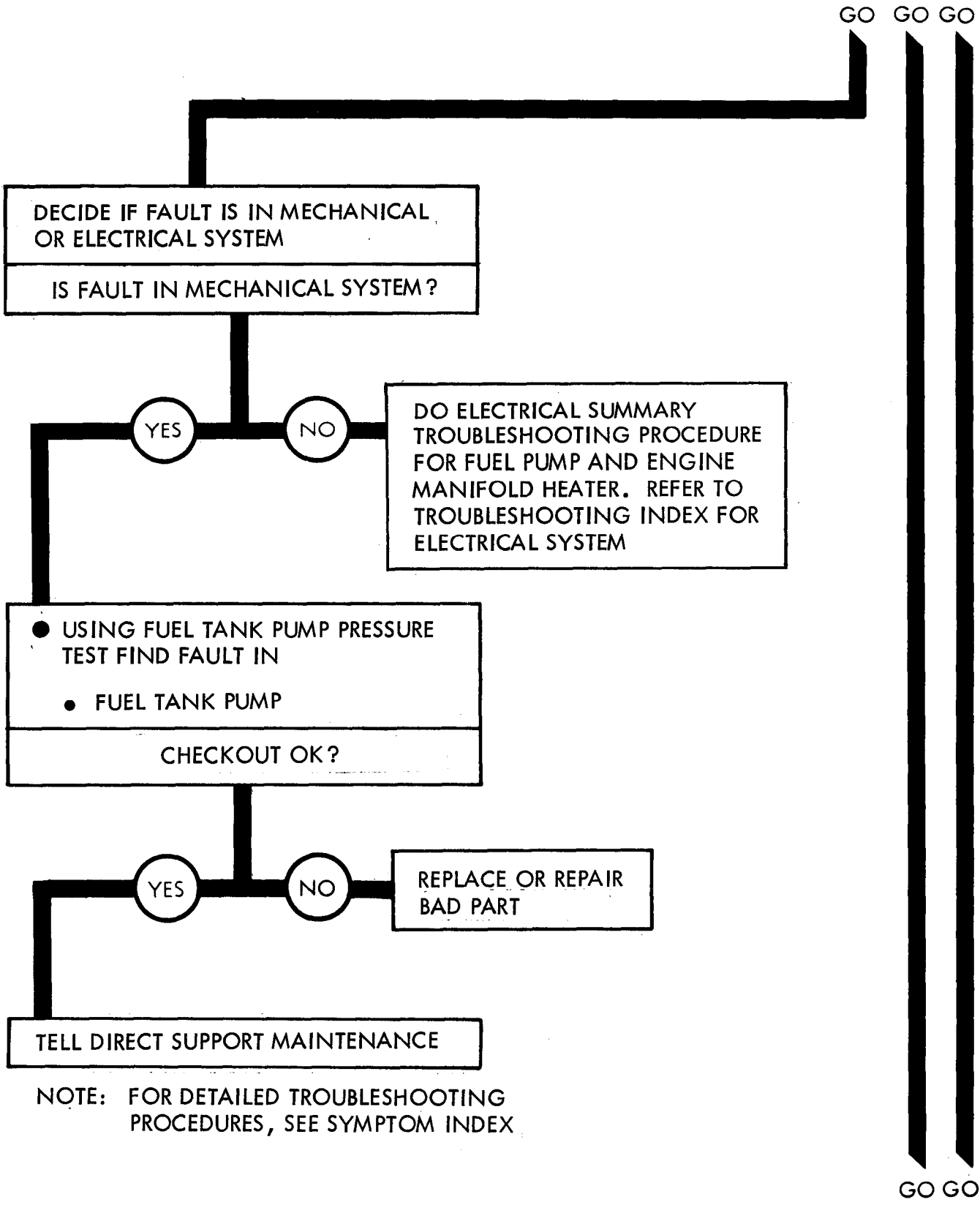

Figure 14-2 (Sheet 2 of 5)



NOTE: FOR DETAILED TROUBLESHOOTING PROCEDURES, SEE SYMPTOM INDEX

Figure 14-2 (Sheet 3 of 5)

TA 114138

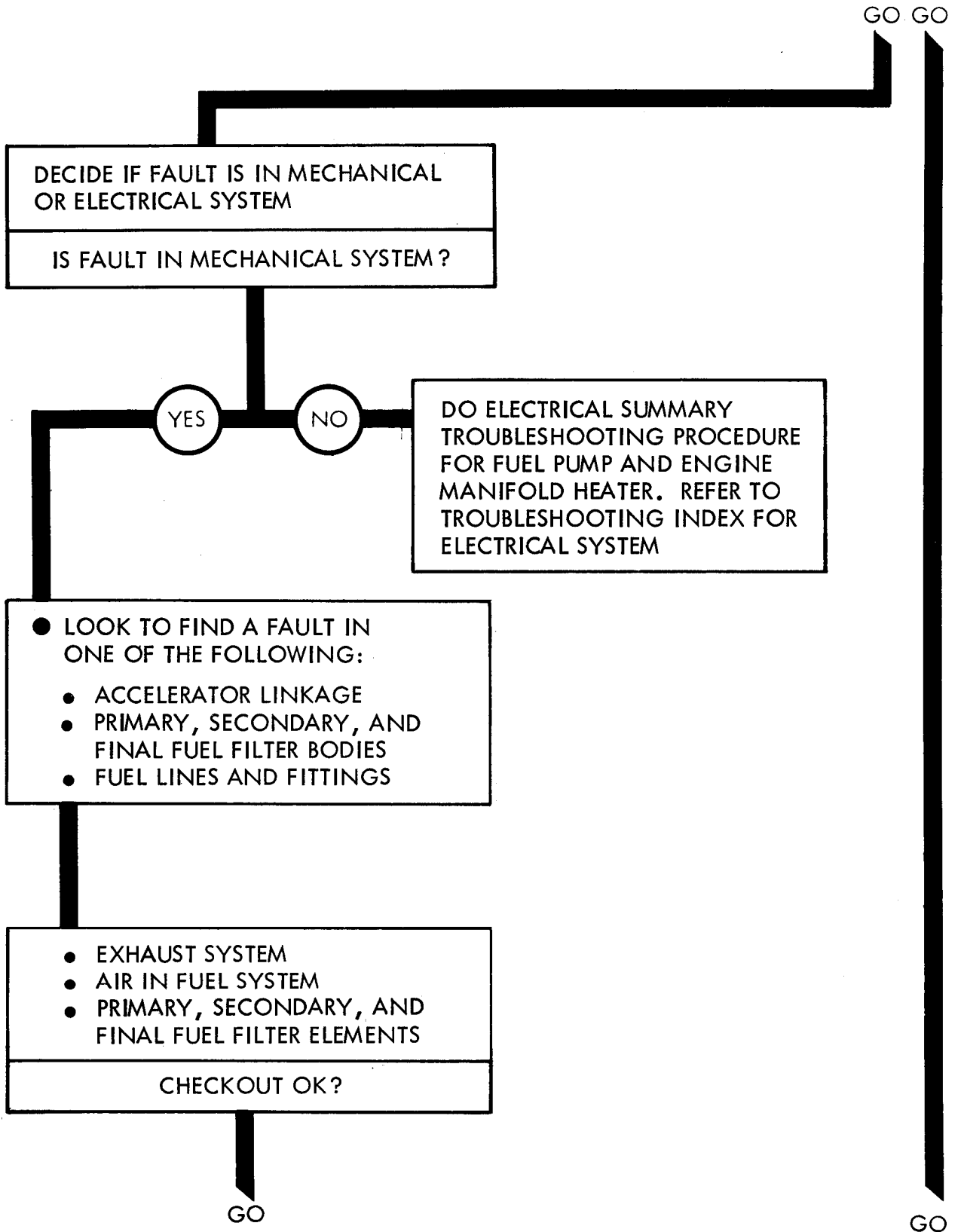
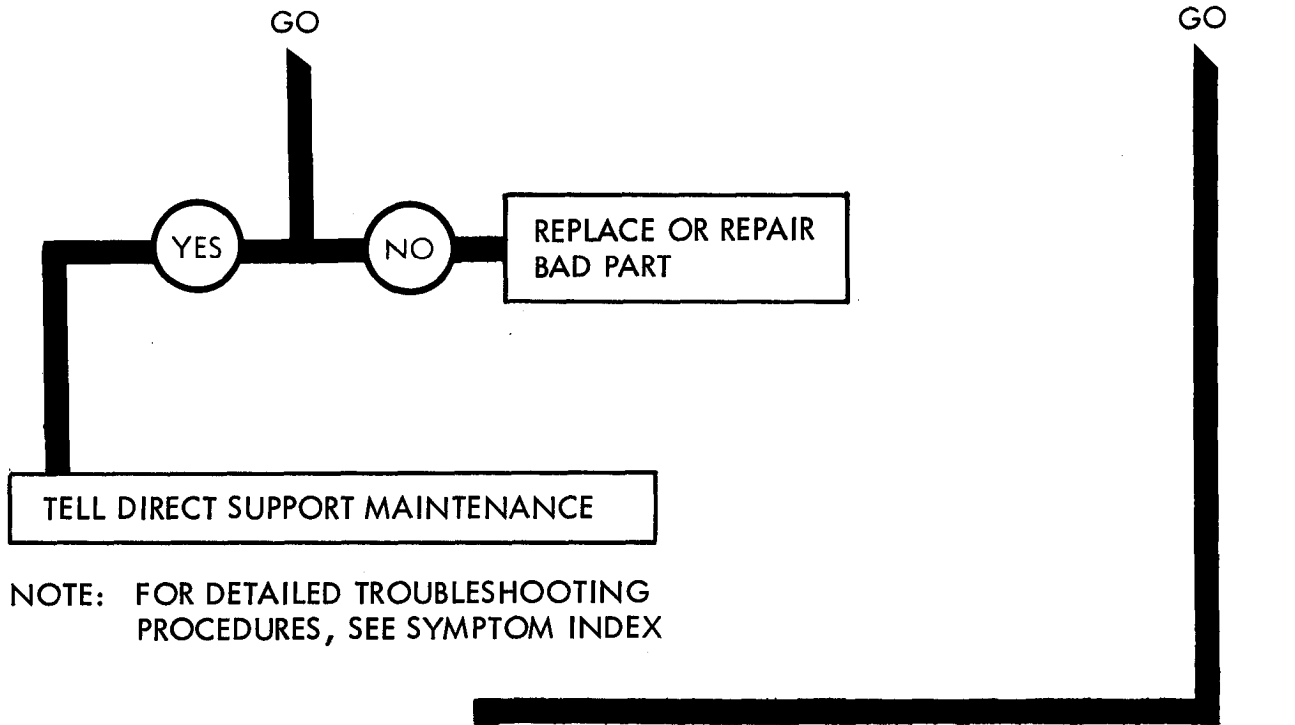
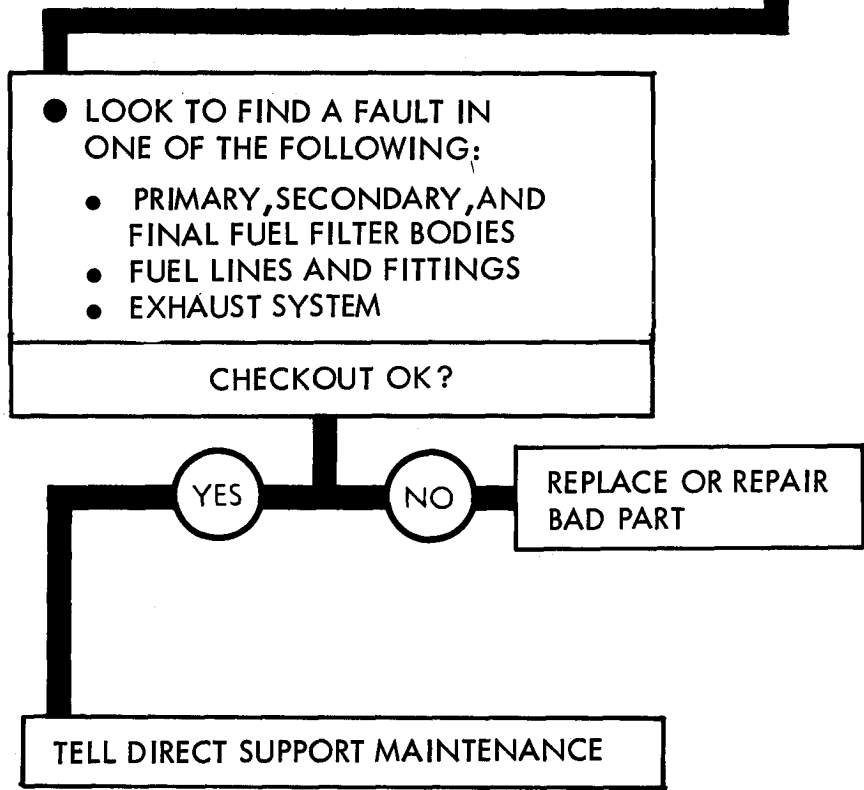

Figure 14-2 (Sheet 4 of 5)



NOTE: FOR DETAILED TROUBLESHOOTING PROCEDURES, SEE SYMPTOM INDEX



NOTE: FOR DETAILED TROUBLESHOOTING PROCEDURES, SEE SYMPTOM INDEX

Figure 14-2 (Sheet 5 of 5)

(TROUBLE WITH SLOWING OR STOPPING ENGINE)

Symptoms

5

ENGINE DOES NOT SLOW
DOWN WHEN ACCELERATOR
PEDAL IS LET GO

ENGINE RUNS AFTER
BEING SHUTOFF



WARNING



DIESEL FUEL IS VERY FLAMMABLE. CARE MUST BE
USED WHEN CHOOSING A PLACE TO WORK ON FUEL
SYSTEM . KEEP TRUCK ABOUT 50 FEET AWAY FROM AN
AREA WHERE OPEN FLAME, SPARKS, OR SMOKING
MAY CAUSE A FIRE. KEEP A FIRE EXTINGUISHER CLOSE BY



GO

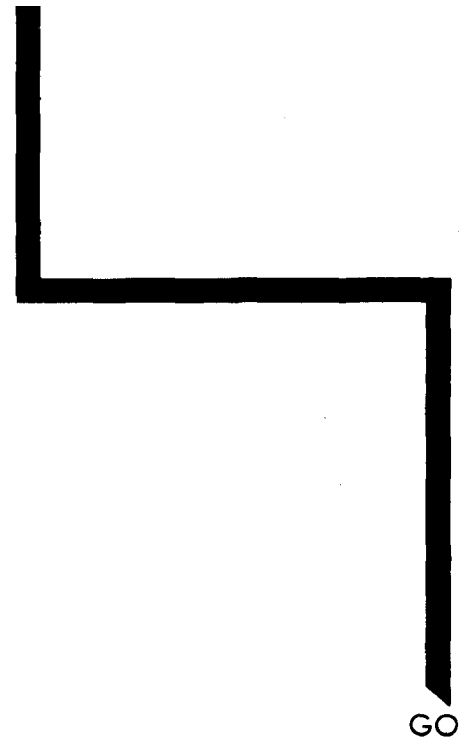

GO

Figure 14-3 (Sheet 1 of 3)

TA 114141

GO

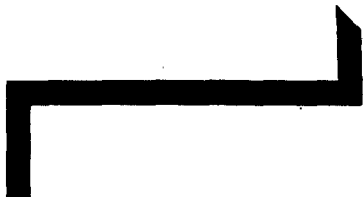

- LOOK TO FIND A FAULT IN ONE OF THE FOLLOWING:
 - ACCELERATOR RETURN SPRING
 - FUEL RETURN LINES
 - ACCELERATOR LINKAGE RETURN

CHECKOUT OK?

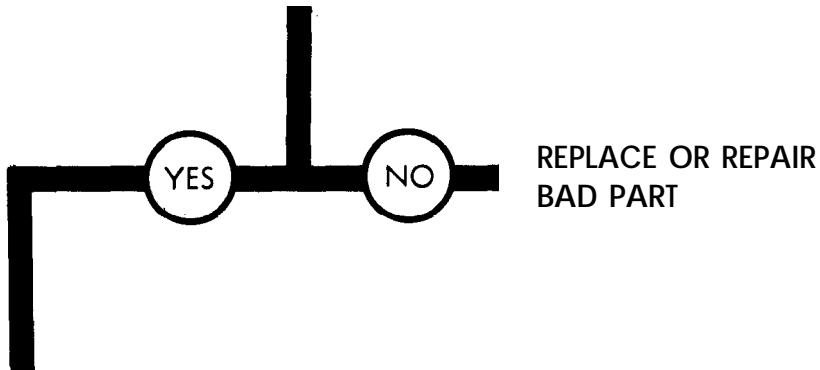

TELL DIRECT SUPPORT MAINTENANCE

NOTE: FOR DETAILED TROUBLESHOOTING PROCEDURES, SEE SYMPTOM INDEX

GO



GO

TA 114142

Figure 14-3 (Sheet 2 of 3)

GO

- LOOK TO FIND A FAULT IN ONE OF THE FOLLOWING:
 - FUEL RETURN LINES
 - ACCELERATOR LINKAGE RETURN

CHECKOUT OK?

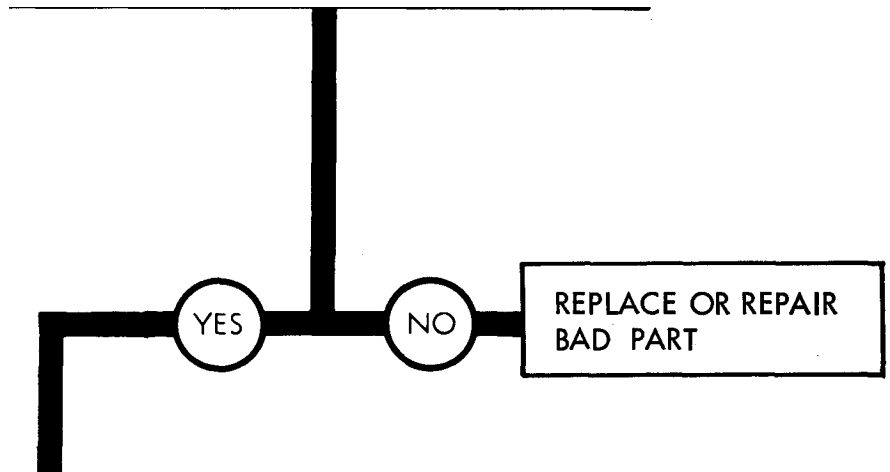

TELL DIRECT SUPPORT MAINTENANCE

NOTE: FOR DETAILED TROUBLESHOOTING PROCEDURES, SEE SYMPTOM INDEX

CHAPTER 15

FUEL SYSTEM SUPPORT DIAGRAMS

15-1. GENERAL. This chapter gives the diagrams you need when doing **trouble-** shooting procedures in chapter 13. Table 3-1 is a complete listing of all support diagrams used in this manual.

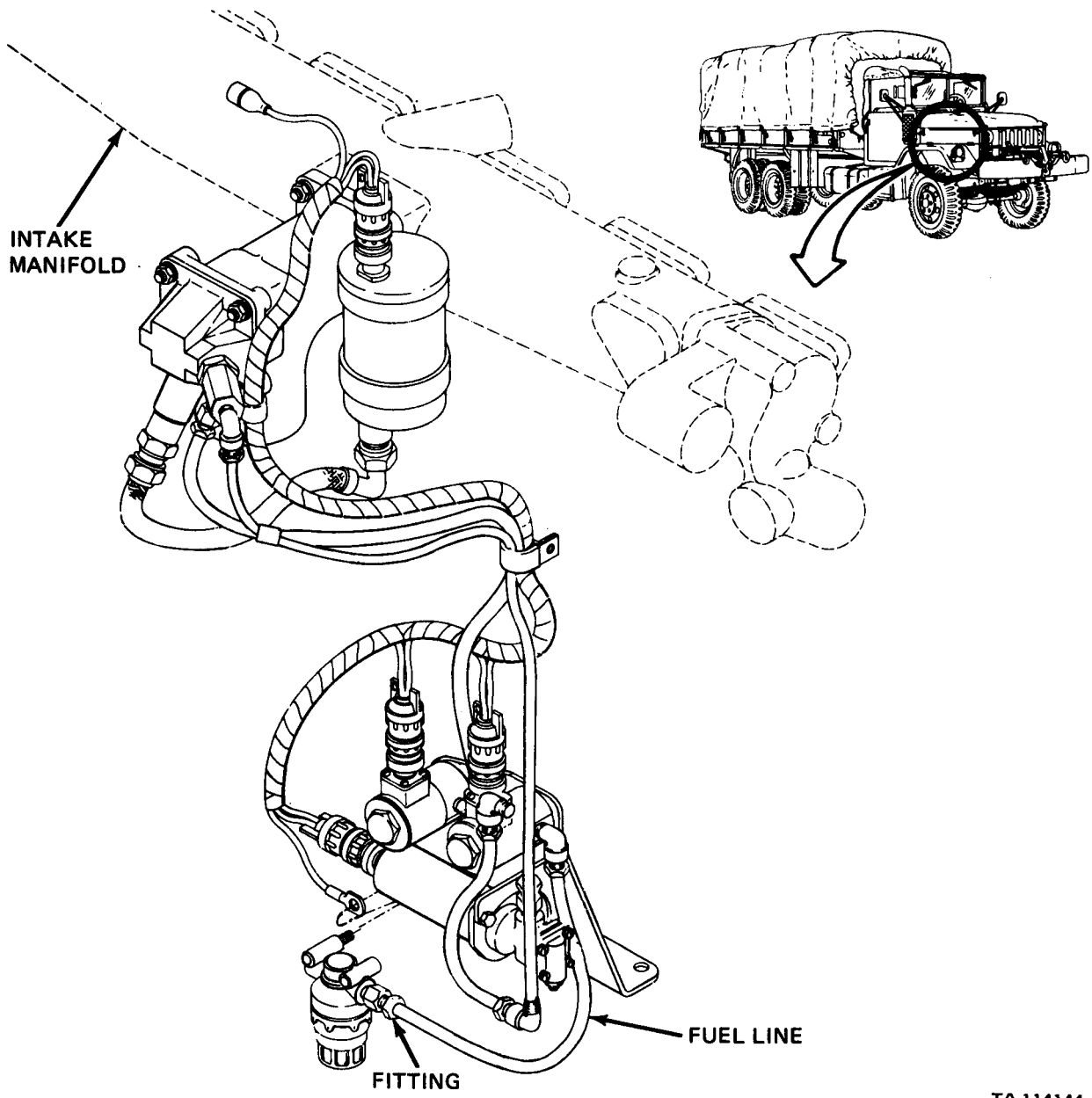

TA 114144

Figure 15-1. Fuel System Support Diagram

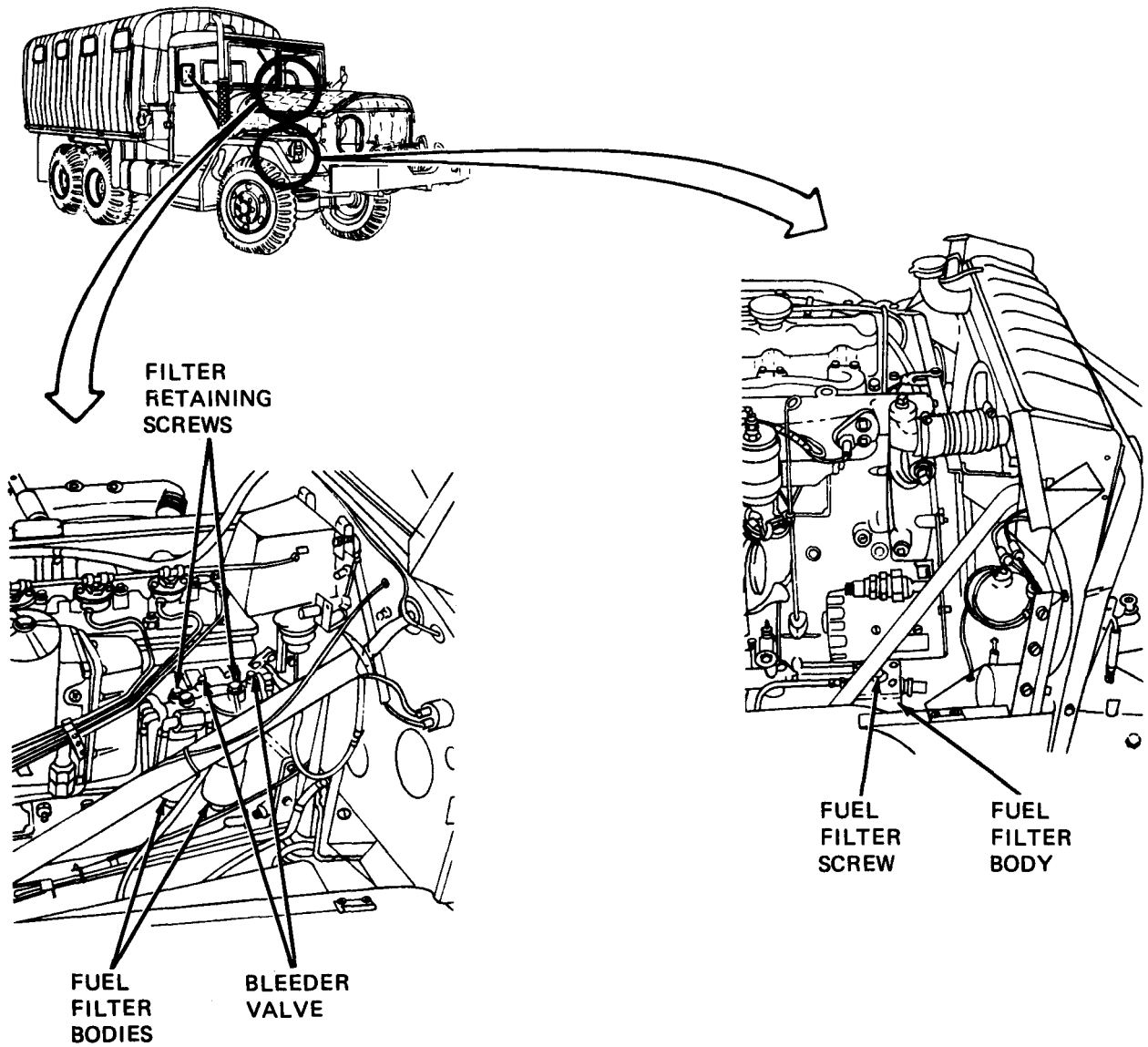

TA 114145

Figure 15-2. Fuel System Support Diagram

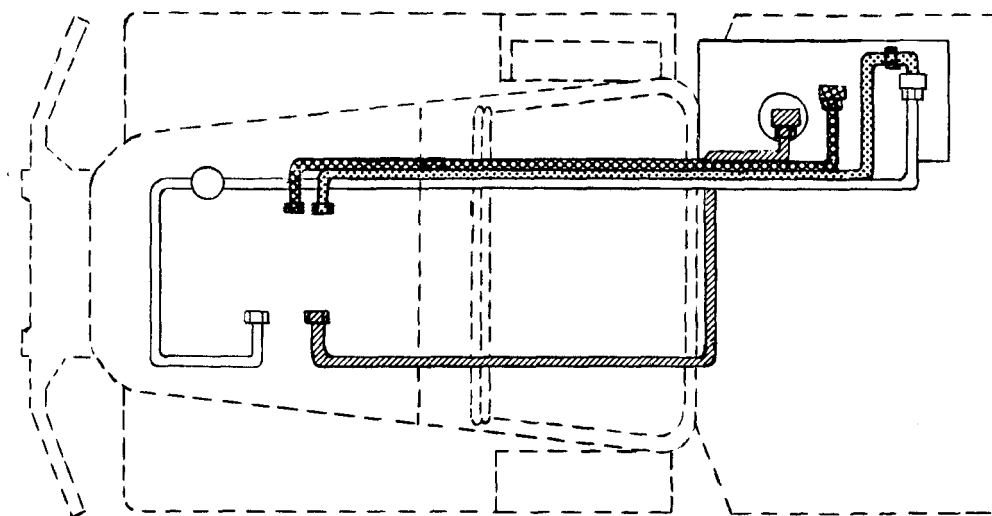
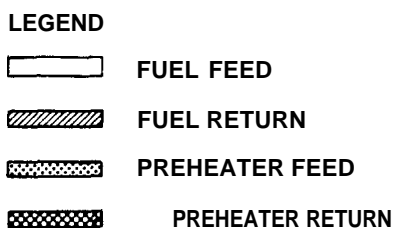

FUEL LINES AND FITTINGS FOR LDS427

TA 114146

Figure 15-3. Fuel System Support Diagram

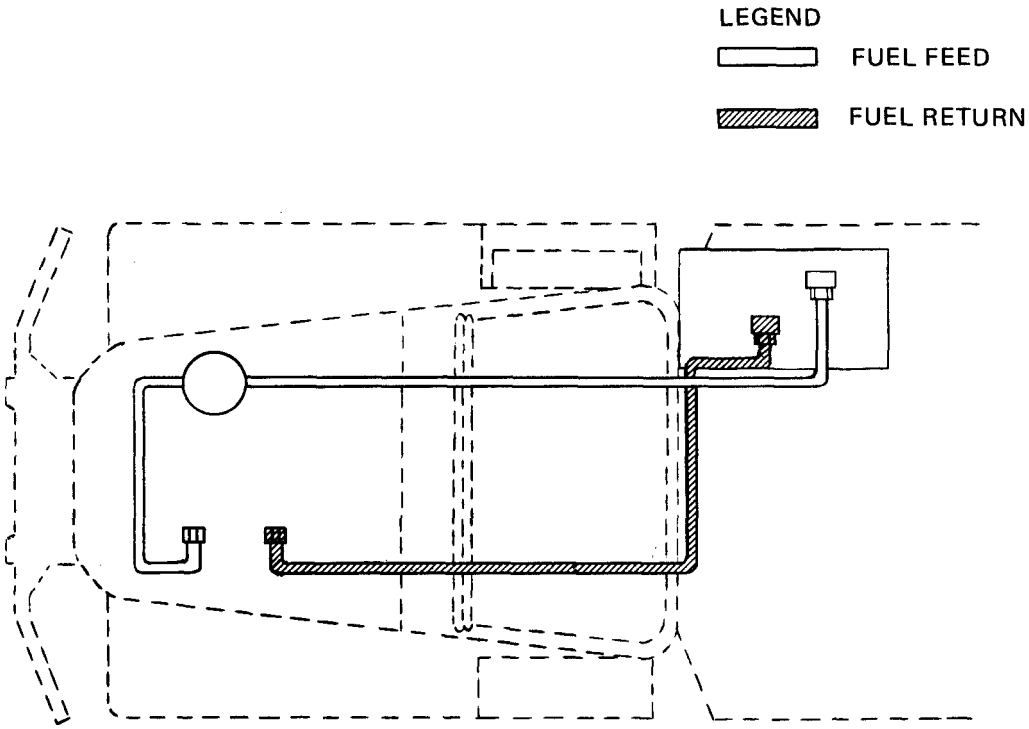

FUEL LINES AND FITTINGS FOR LD465

TA 114147

Figure 15-4. Fuel System Support Diagram

PREHEATER FEED
FUEL FEED
PREHEATER RETURN
FUEL RETURN

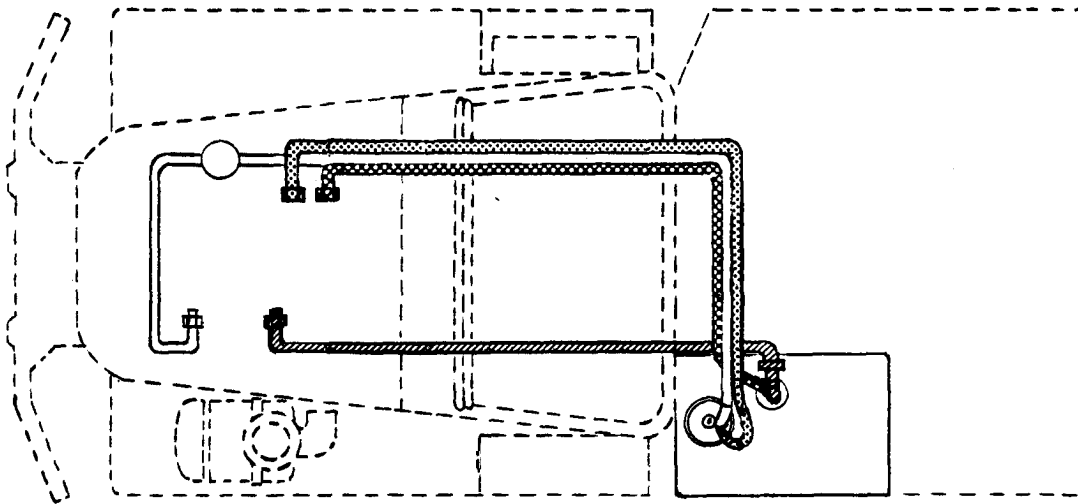

FUEL LINES AND FITTINGS FOR THE M275A1

TA 114148

Figure 15-5. Fuel System Support Diagram

CHAPTER 16

FUEL SYSTEM TEST PROCEDURES

16-1. GENERAL. This chapter gives test procedures for the tests given in chapter 13 for the fuel system.

16-2. TEST SET-UP. Instructions for setup of test equipment and parts to be tested are given before the test procedures. Illustrations are used, when needed, to show you how to hook up the test equipment to the part to be tested.

16-3. TEST PROCEDURE. Detailed step-by-step instructions, in flow chart form, are given for each test. The procedure calls out the type of test and the condition of the truck system for each part of testing. The step-by-step test will lead you to the bad component or to a fault symptom within a related system. Reference is made to the fault symptom index, chapter 6, if the test shows a fault in another system.

FUEL SYSTEM TROUBLESHOOTING TESTS

FLAME HEATER FUEL PUMP TEST

- Test heater fuel pump
 - Using 3/8-inch wrench unscrew and take off fuel lines from nozzle
 - Put fuel line fitting ends into a bucket, or can
 - Turn on heater for about 15 seconds then turn heater off
 - See if there is fuel in bucket, or can

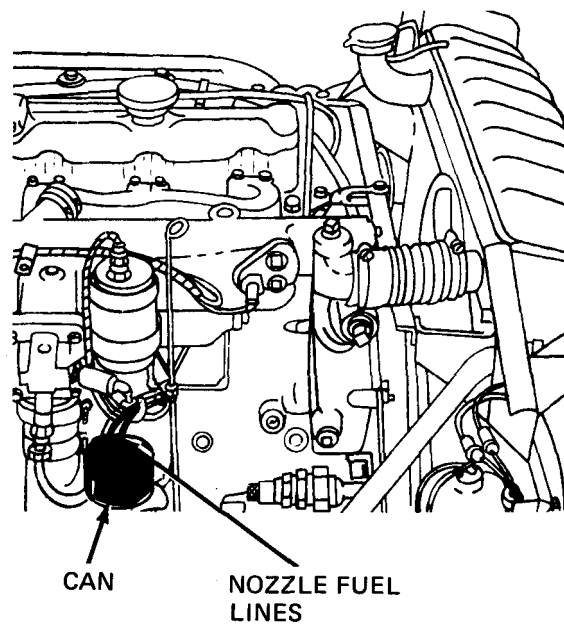
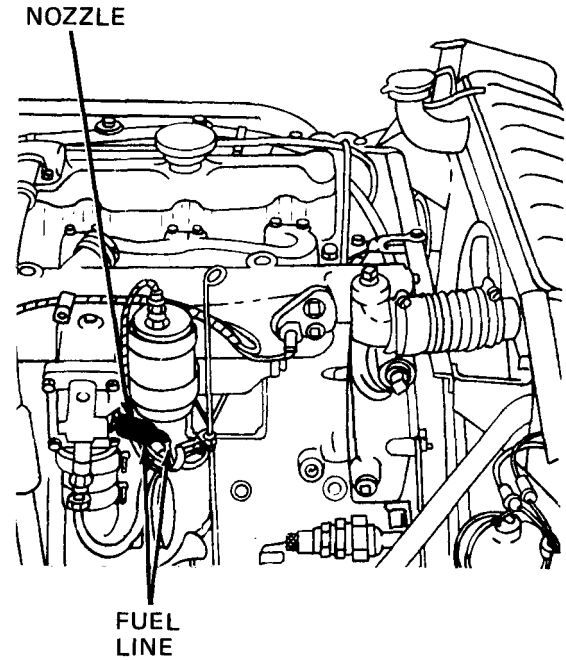

Figure 16-1

TA 114149

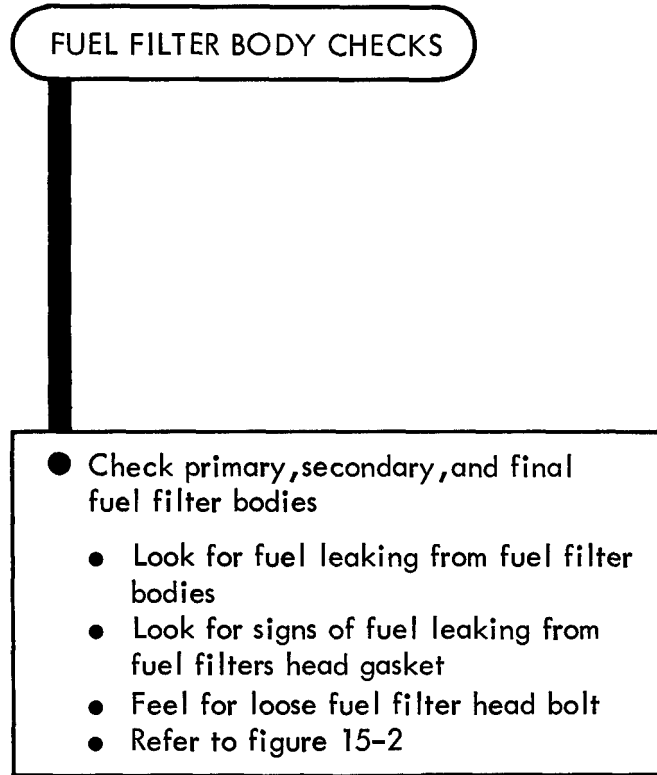

Figure 16-2

FLAME HEATER NOZZLE TEST

- Test flame heater nozzle
 - Using 5/16 and 7/16 inch wrenches unscrew two fuel line fittings
 - Using 1-inch wrench unscrew and shake out flame heater nozzle
 - Screw fuel line fittings into nozzle and tighten using 7/16 and 5/16 inch wrenches

- Put a bucket or can under flame heater nozzle
- Turn on heater for about 15 seconds then turn heater off
- See if there is fuel in bucket or can

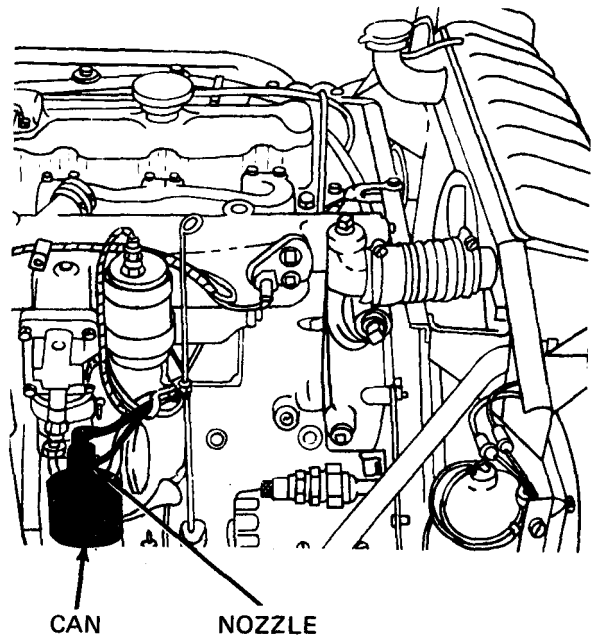

Figure 16-3

TA 114151

FUEL LINES AND FITTINGS CHECKS

- Check all fuel lines and fittings
 - Look for a crushed or broken line.
See figure 15-3, 15-4 and 15-5
 - Look for signs of fuel leaking from lines or fittings
 - Feel for loose fittings

Figure 16-4

FUEL TANK PUMP PRESSURE TEST

● Test fuel tank pump pressure

Remove fuel pump output line from elbow. Refer to Vol 3, chapter 4, para 4-5

Put Pressure gage fitting in elbow and tighten using 1/2-inch wrench

Turn accessory switch to "ON". Refer to TM 9-2320-209-10

See if gage reading is between 5 and 7 psi

Turn switch to "OFF". Refer to TM 9-2320-209- 1.0

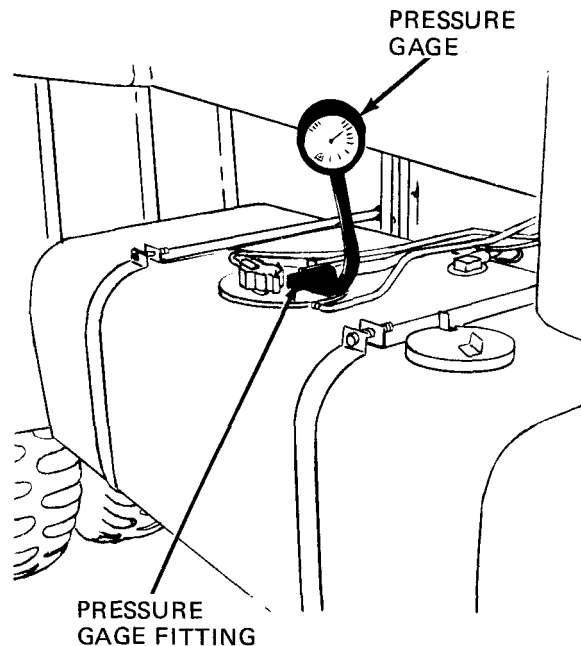

- Using 1/2-inch wrench unscrew and take out pressure gage fitting
- Put back fuel line. Refer to Vol 3, chapter 4, para 4-5

TA 114153

Figure 16-5

CHAPTER 17

EXHAUST SYSTEM TROUBLESHOOTING

17-1. EQUIPMENT ITEMS COVERED. This chapter gives equipment troubleshooting procedures for the exhaust system, for which there are authorized corrective maintenance tasks at the organizational maintenance level.

17-2. EQUIPMENT ITEMS NOT COVERED . All equipment items for which corrective maintenance is authorized at the organizational maintenance level are covered in this chapter.

EXHAUST SYSTEM TROUBLESHOOTING

Symptom

1 EXHAUST SYSTEM MAKES NOISE FROM HORIZONTAL EXHAUST SYSTEM WITH MUFFLER

1

- Make truck ready for work on exhaust system
 - Park truck. Refer to TM 9-2320-209-10
 - Chock wheels

WARNING

Do not touch any part of the exhaust system while engine is running. You can get badly burned. If the engine has just been shut off, wait until the exhaust system has time to cool down before doing any work

NOTE

Exhaust manifold is not part of the exhaust system group. However the exhaust manifold should be checked as a cause of the exhaust system making noise

GO

Figure 17-1 (Sheet 1 of 3)

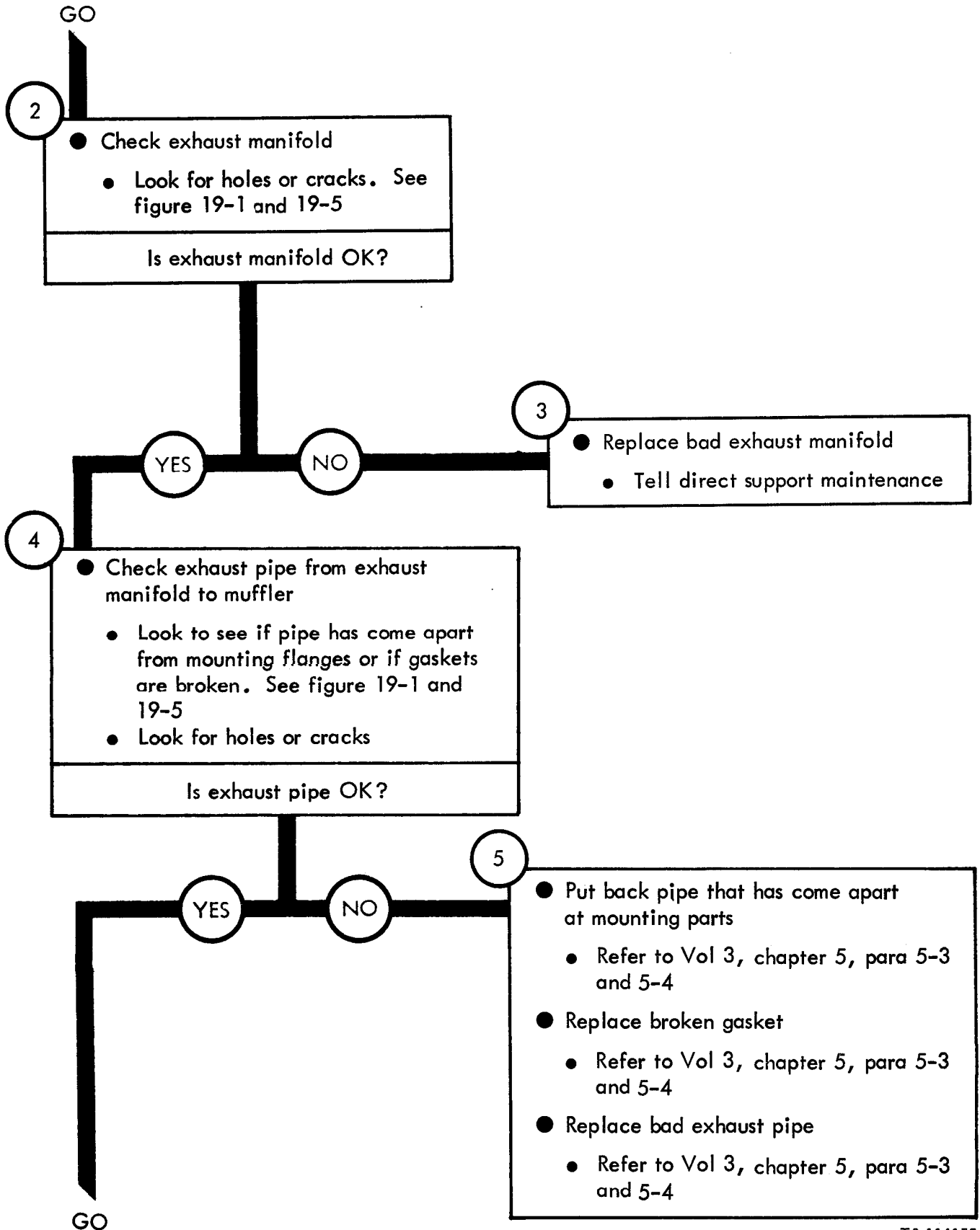

Figure 17-1 (Sheet 2 of 3)

TA 114155

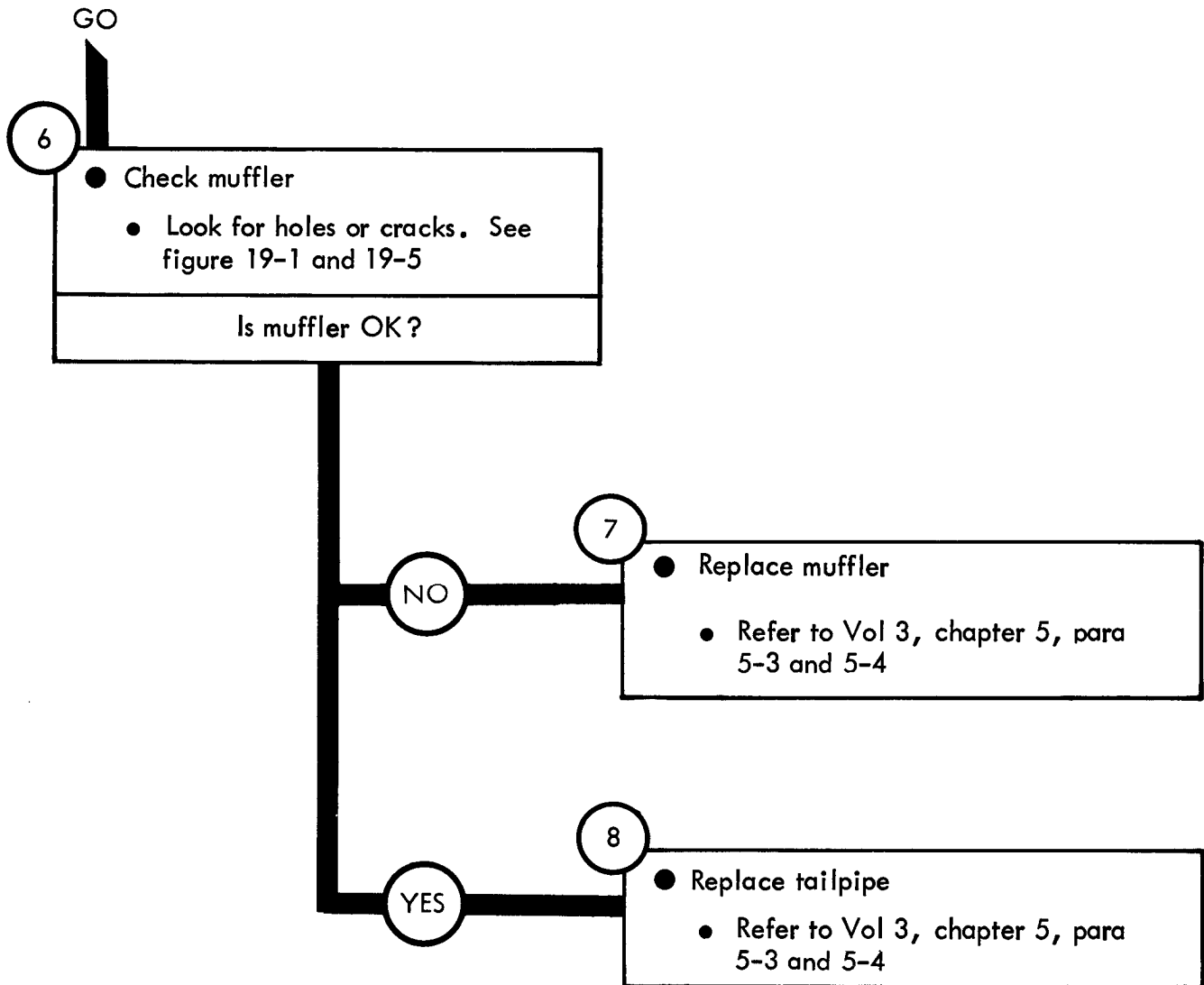

Figure 17-1 (Sheet 3 of 3)

Symptom

2

EXHAUST FUMES ENTER CAB FROM HORIZONTAL EXHAUST SYSTEM WITH MUFFLER

1

- Make truck ready for work on exhaust system
 - Park truck. Refer to TM 9-2320-209-10
 - Chock wheels

WARNING

Do not touch any part of the exhaust system while engine is running. You can get badly burned. If the engine has just been shut off, wait until the exhaust system has time to cool down before doing any work

NOTE

Truck body is not part of the exhaust system group. Holes or cracks in the truck body floor or fire wall can cause fumes to enter cab

GO

Figure 17-2 (Sheet 1 of 2)

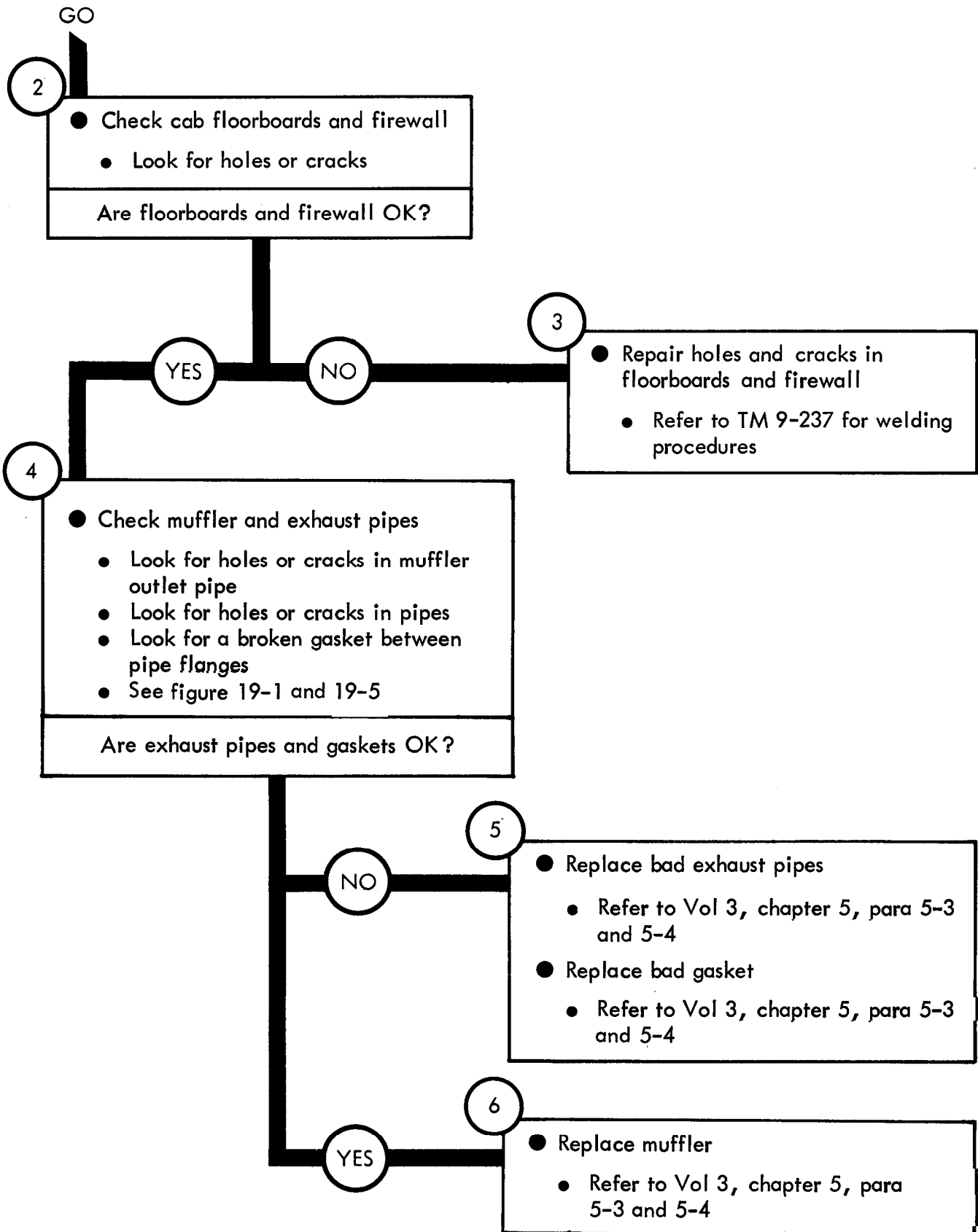

Figure 17-2 (Sheet 2 of 2)

TA 114158

Symptom

3 EXHAUST SYSTEM MAKES NOISE FROM HORIZONTAL EXHAUST SYSTEM WITHOUT MUFFLER

1

- Make truck ready for work on exhaust system
 - Park truck. Refer to TM 9-2320-209-10
 - Chock wheels

WARNING

Do not touch any part of the exhaust system while engine is running. You can get badly burned. If the engine has just been shut off, wait until the exhaust system has time to cool down before doing any work

NOTE

Exhaust manifold and turbocharger are not part of the exhaust system group. However the exhaust manifold and turbocharger should be checked as a cause of the exhaust system making noise

GO

Figure 17-3 (Sheet 1 of 3)

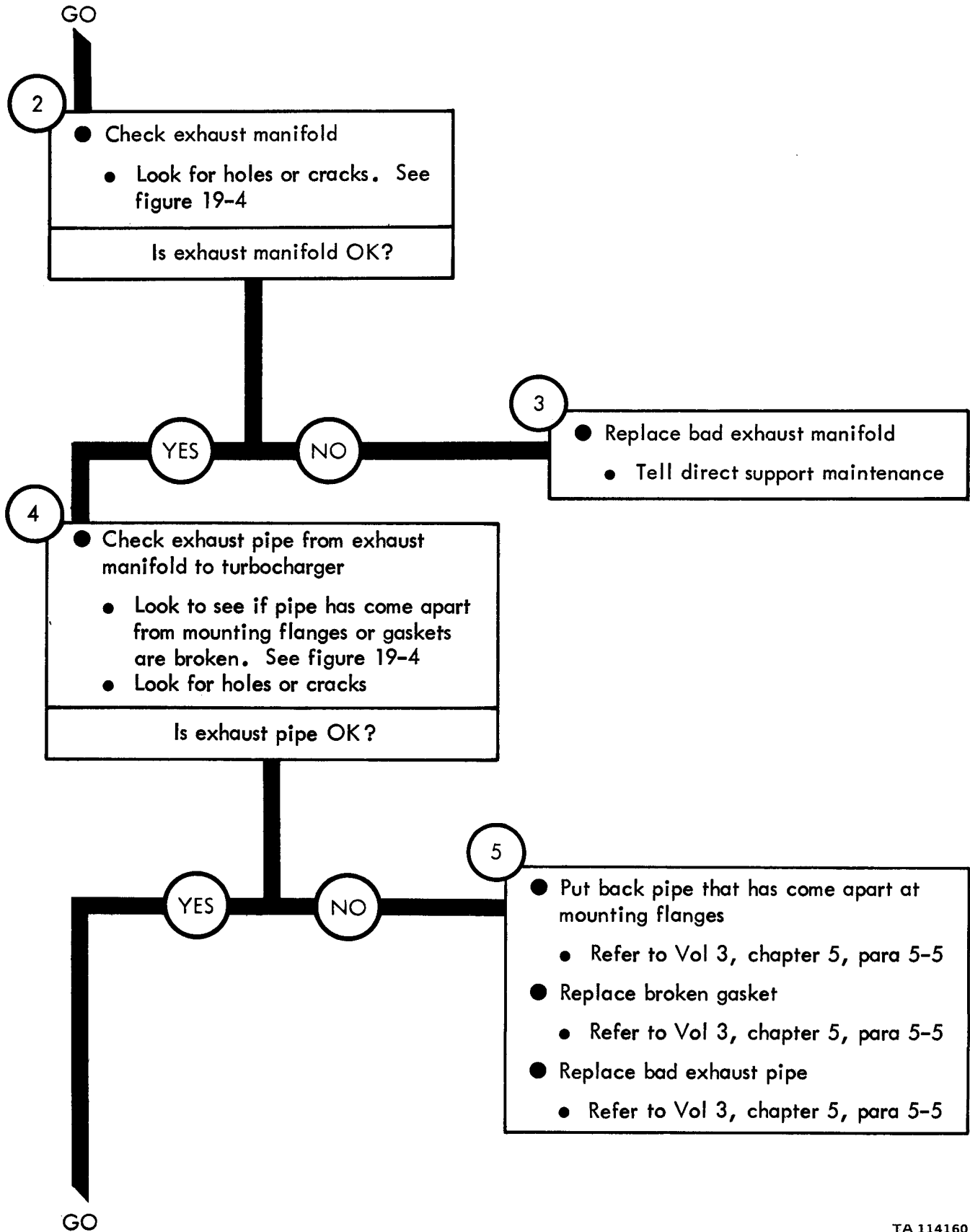

TA 114160

Figure 17-3 (Sheet 2 of 3)

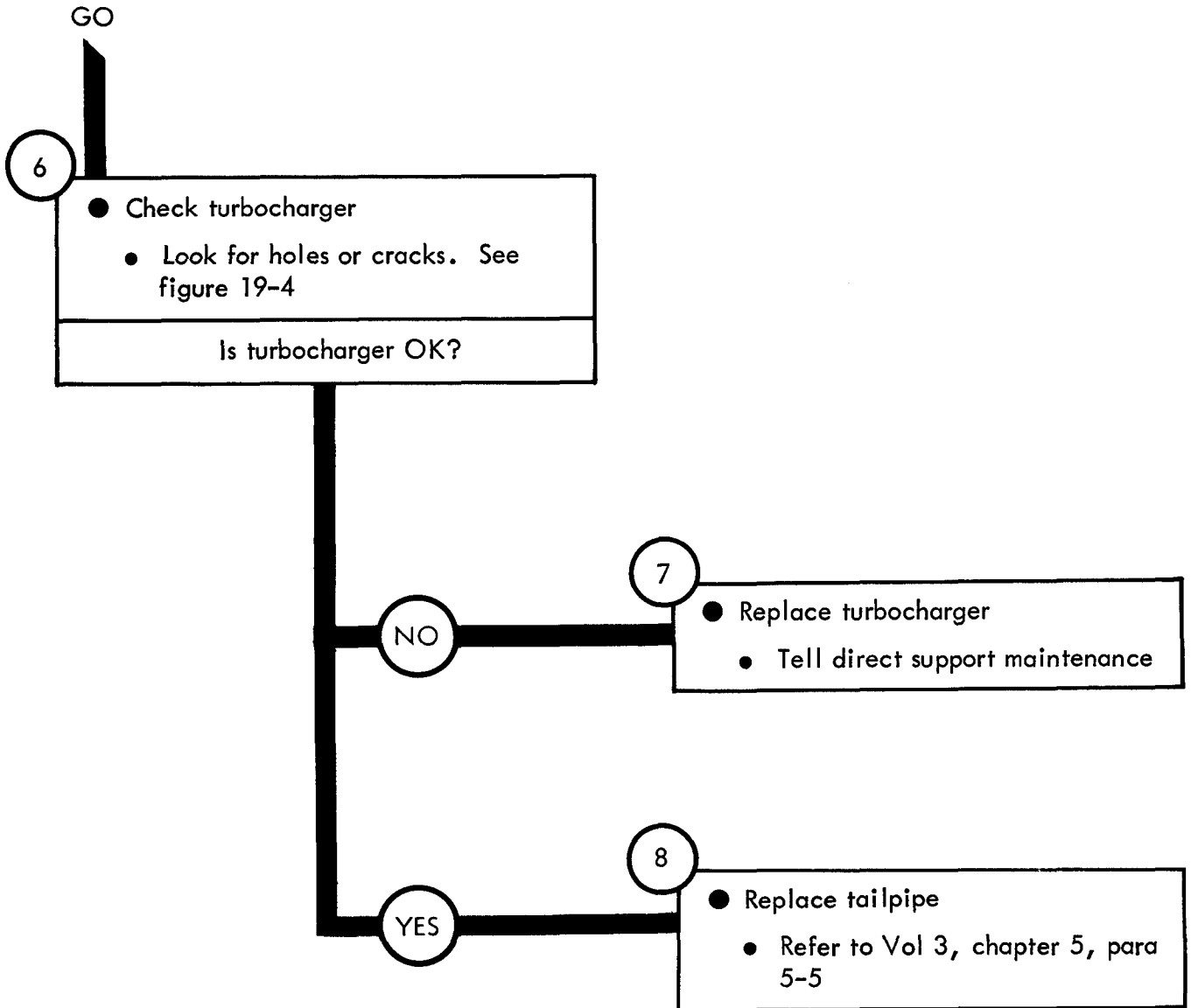

Figure 17-3 (Sheet 3 of 3)

Symptom

4

EXHAUST FUMES ENTER CAB FROM HORIZONTAL EXHAUST SYSTEM WITHOUT MUFFLER

1

- Make truck ready for work on exhaust system
 - Park truck. Refer to TM 9-2320-209-10
 - Chock wheels

WARNING

Do not touch any part of the exhaust system while engine is running. You can get badly burned. If the engine has just been shut off, wait until the exhaust system has time to cool down before doing any work

NOTE

Truck body is not part of the exhaust system group. Holes or cracks in the truck body floor or firewall can cause fumes to enter cab

2

- Check cab floorboards and firewall
 - Look for holes or cracks

Are floorboards and firewall OK?

GO

Figure 17-4 (Sheet 1 of 2)

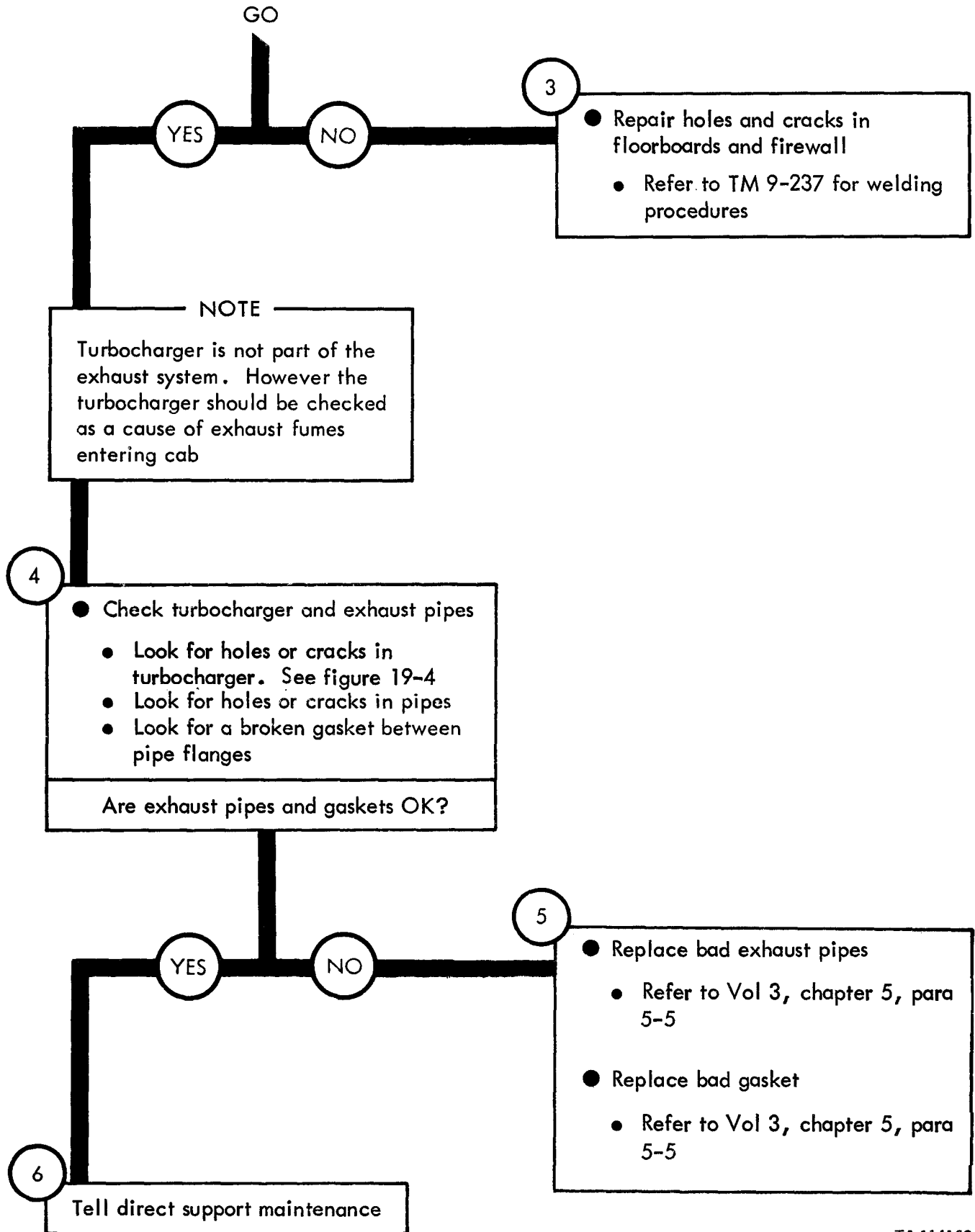

' Figure 17-4 (Sheet 2 of 2)

TA 114163

Symptom

5 EXHAUST SYSTEM MAKES NOISE FROM VERTICAL EXHAUST SYSTEM WITH MUFFLER

1

- Make truck ready for work on exhaust system
 - Park truck. Refer to TM 9-2320-209-10
 - Chock wheels

WARNING

To not touch any part of the exhaust system while engine is running. You can get badly burned. If the engine has just been shut off, wait until the exhaust system has time to cool down before doing any work

NOTE

Exhaust manifold is not part of the exhaust system group. However the exhaust manifold should be checked as a cause of the exhaust system making noise

GO

Figure 17-5 (Sheet 1 of 3)

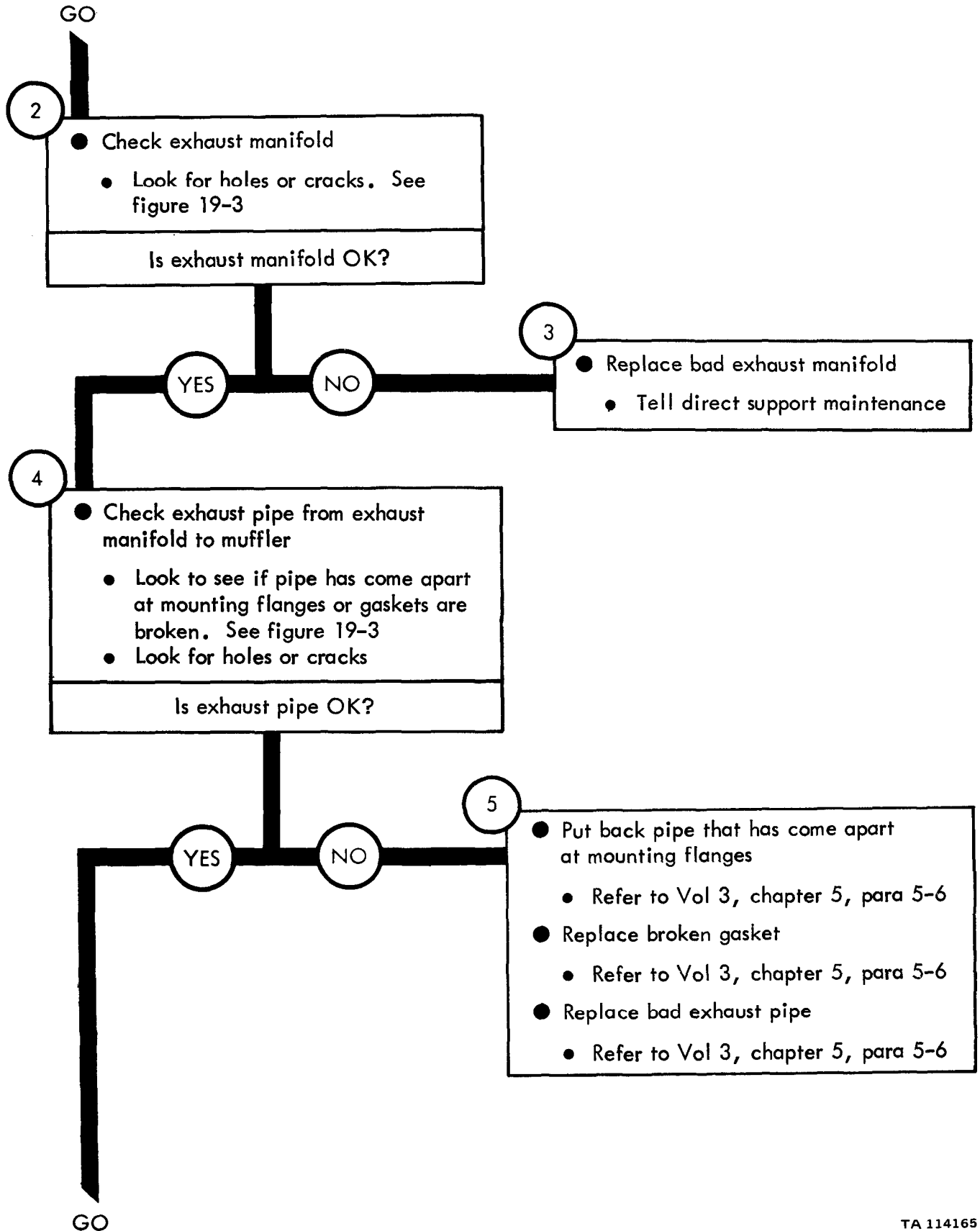

Figure 17-5 (Sheet 2 of 3)

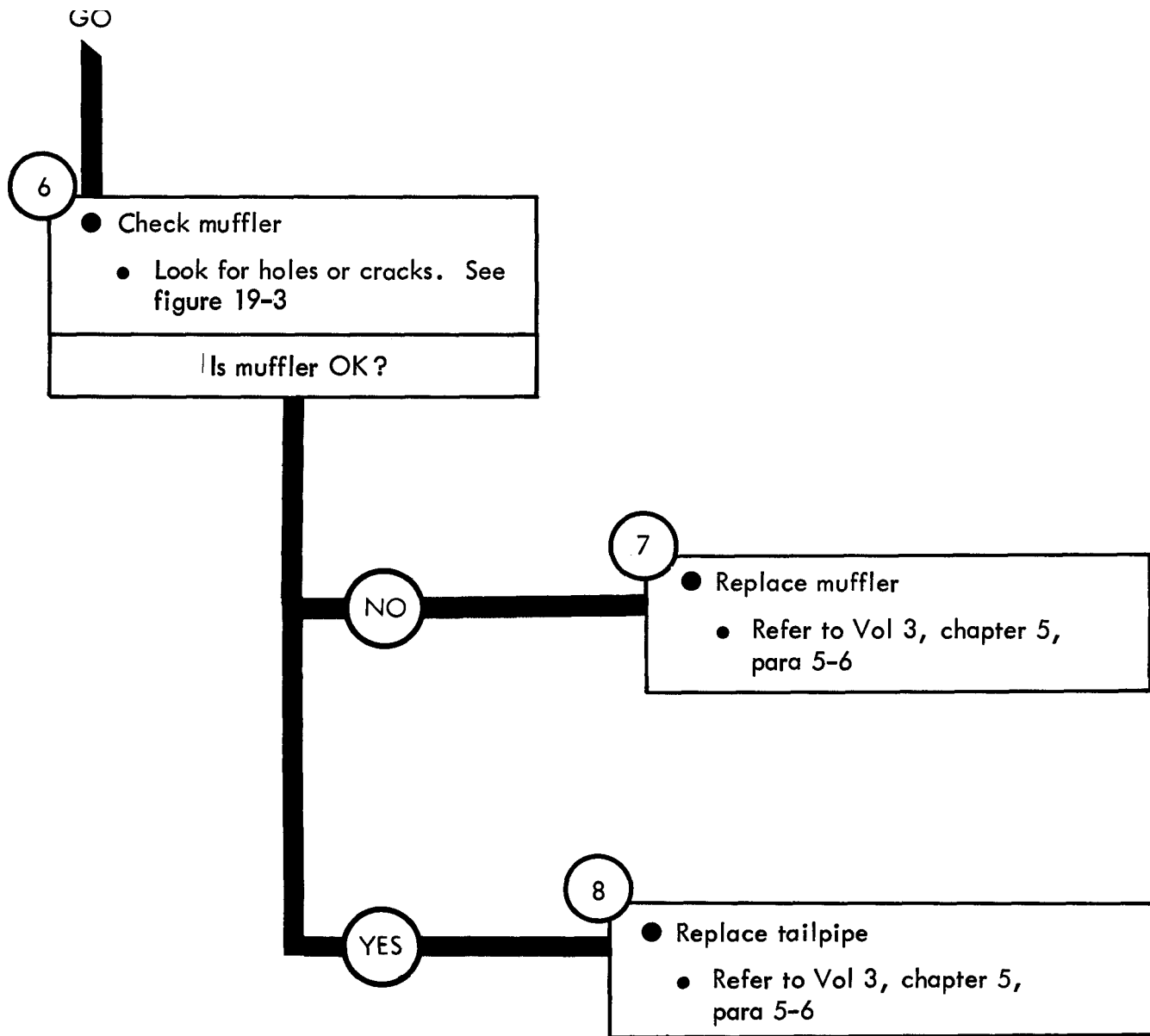

Figure 17-5 (Sheet 3 of 3)

Symptom

6

EXHAUST FUMES ENTER CAB FROM VERTICAL EXHAUST SYSTEM WITH MUFFLER

1

- Make truck ready for work on exhaust system
 - Park truck. Refer to TM 9-2320-209-10
 - Chock wheels

— WARNING —

Do not touch any part of the exhaust system while engine is running. You can get badly burned. If the engine has just been shut off, wait until the exhaust system has time to cool down before doing any work

— NOTE —

Truck body is not part of the exhaust system group. Holes or cracks in the truck body floor or firewall can cause fumes to enter cab

GO

Figure 17-6 (Sheet 1 of 2)

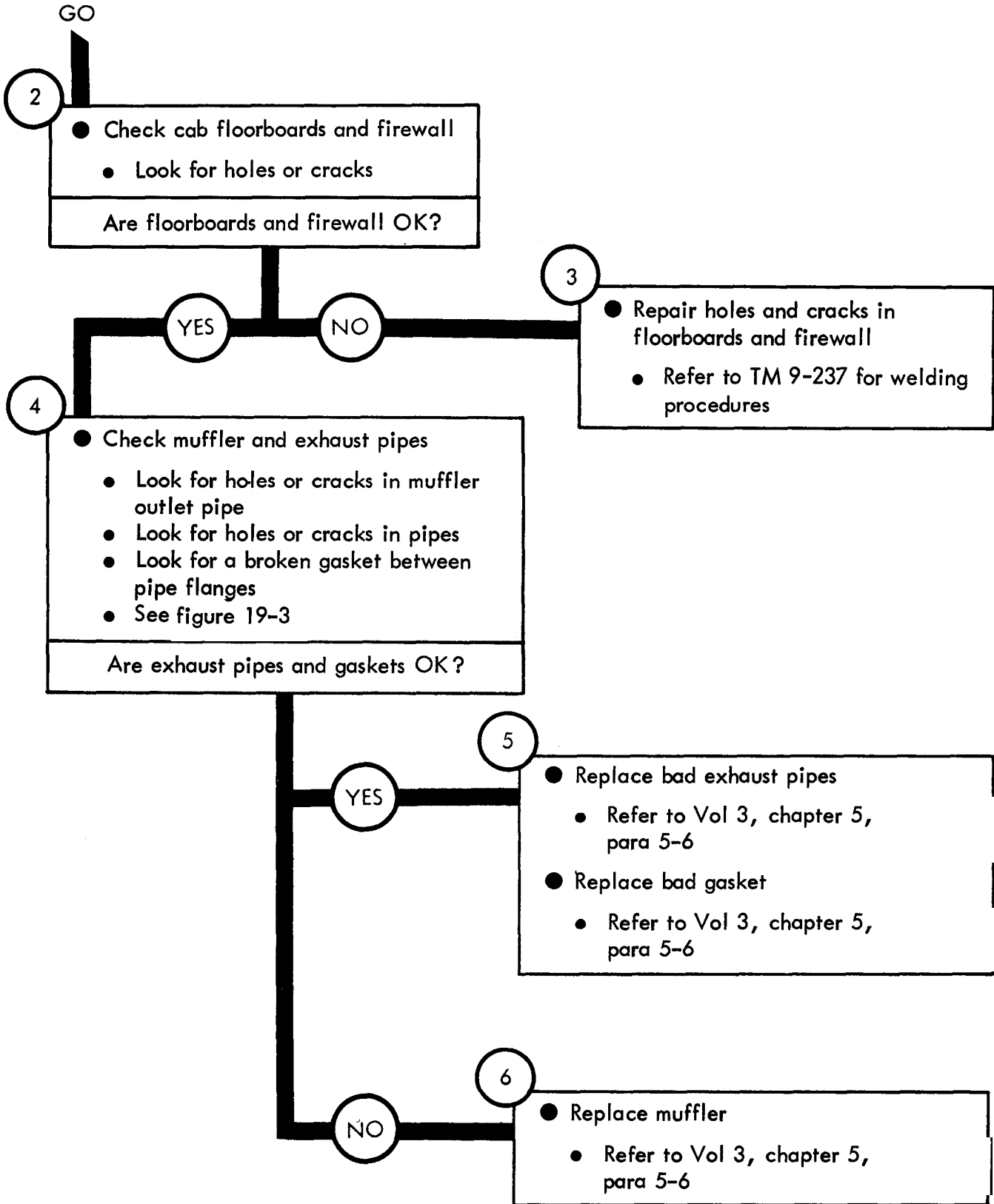

Figure 17-6 (Sheet 2 of 2)

Symptom

7

EXHAUST SYSTEM MAKES NOISE FROM VERTICAL EXHAUST SYSTEM WITHOUT MUFFLER

1

- Make truck ready for work on exhaust system
 - Park truck. Refer to TM 9-2320-209-10
 - Chock wheels

WARNING

Do not touch any part of the exhaust system while engine is running. You can get badly burned. If the engine has just been shut off, wait until the exhaust system has time to cool down before doing any work

NOTE

Exhaust manifold and turbocharger are not part of the exhaust system group. However the exhaust manifold and turbocharger should be checked as a cause of the exhaust system making noise

GO

Figure 17-7 (Sheet 1 of 3)

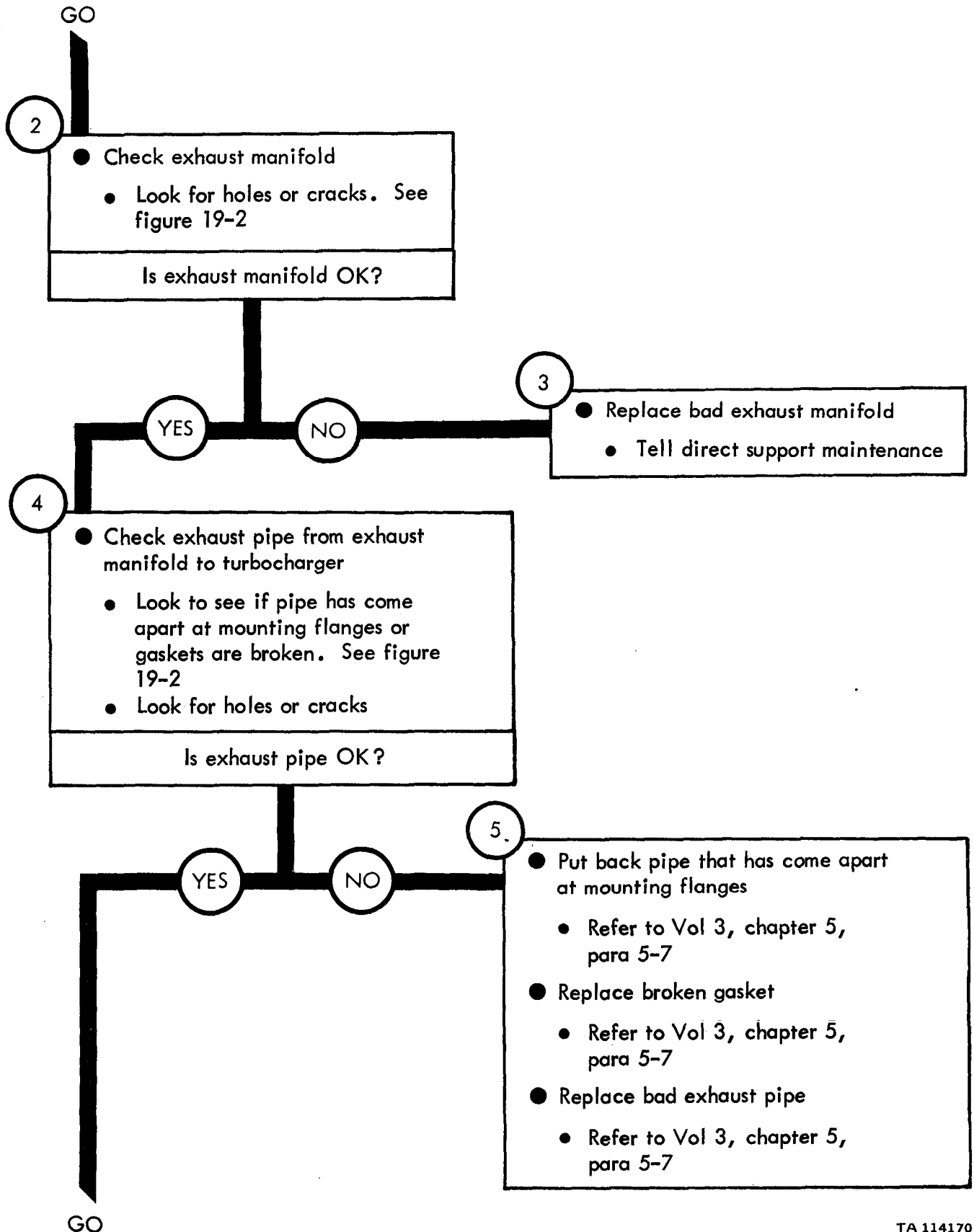
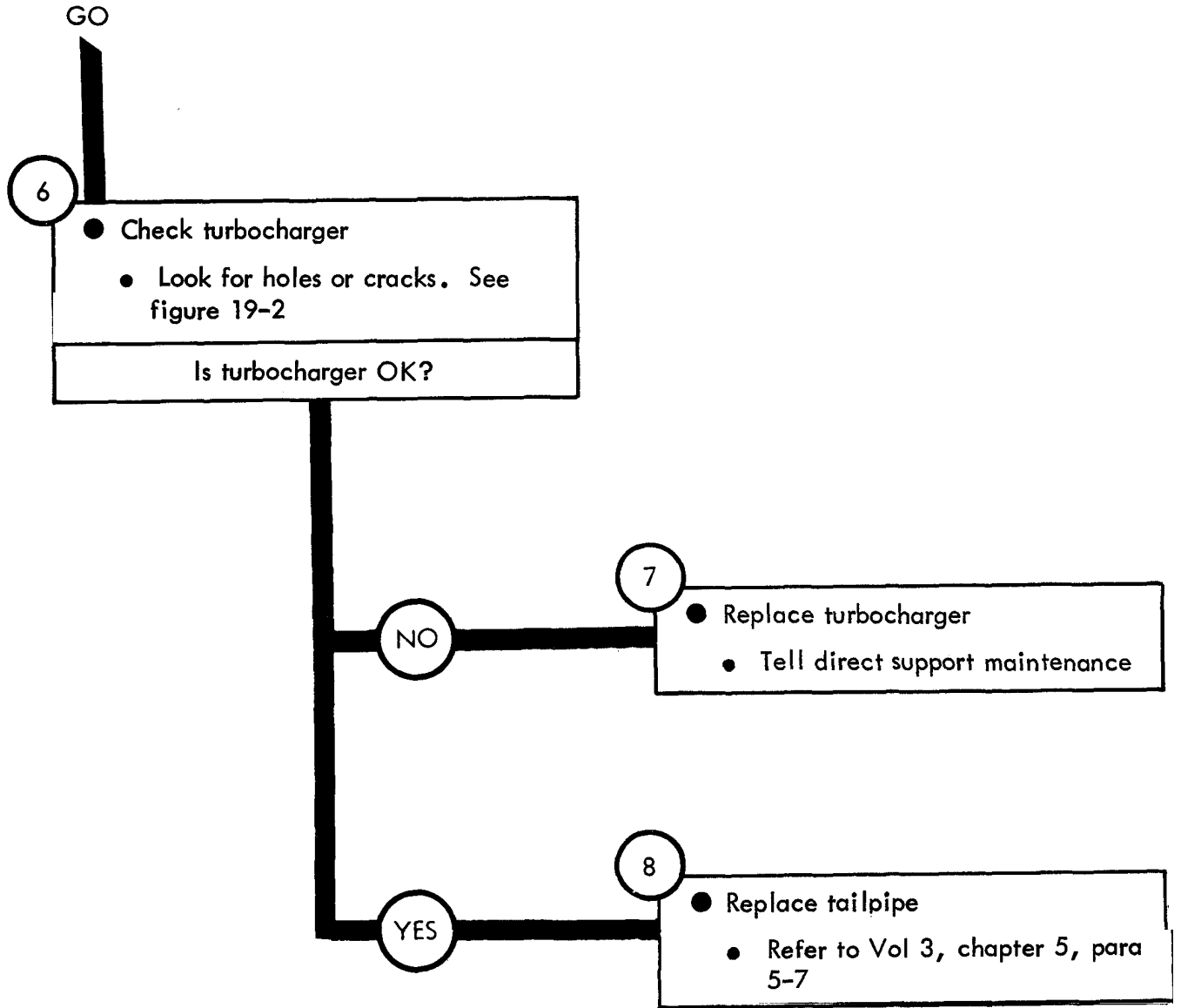

Figure 17-7 (Sheet 2 of 3)

TA 114170



Symptom

8 EXHAUST FUMES ENTER CAB FROM VERTICAL EXHAUST SYSTEM WITHOUT MUFFLER

- 1
- Make truck ready for work on exhaust system
 - Park truck. Refer to TM 9-2320-209-10
 - Chock wheels

WARNING

Do not touch any part of the exhaust system while engine is running. You can get badly burned. If the engine has just been shut off, wait until the exhaust system has time to cool down before doing any work

NOTE

Truck body is not part of the exhaust system group. Holes or cracks in the truck body floor or firewall can cause fumes to enter cab

- 2
- Check cab floorboards and firewall
 - Look for holes or cracks

Are floorboards and firewall OK?

GO

Figure 17-8 (Sheet 1 of 2)

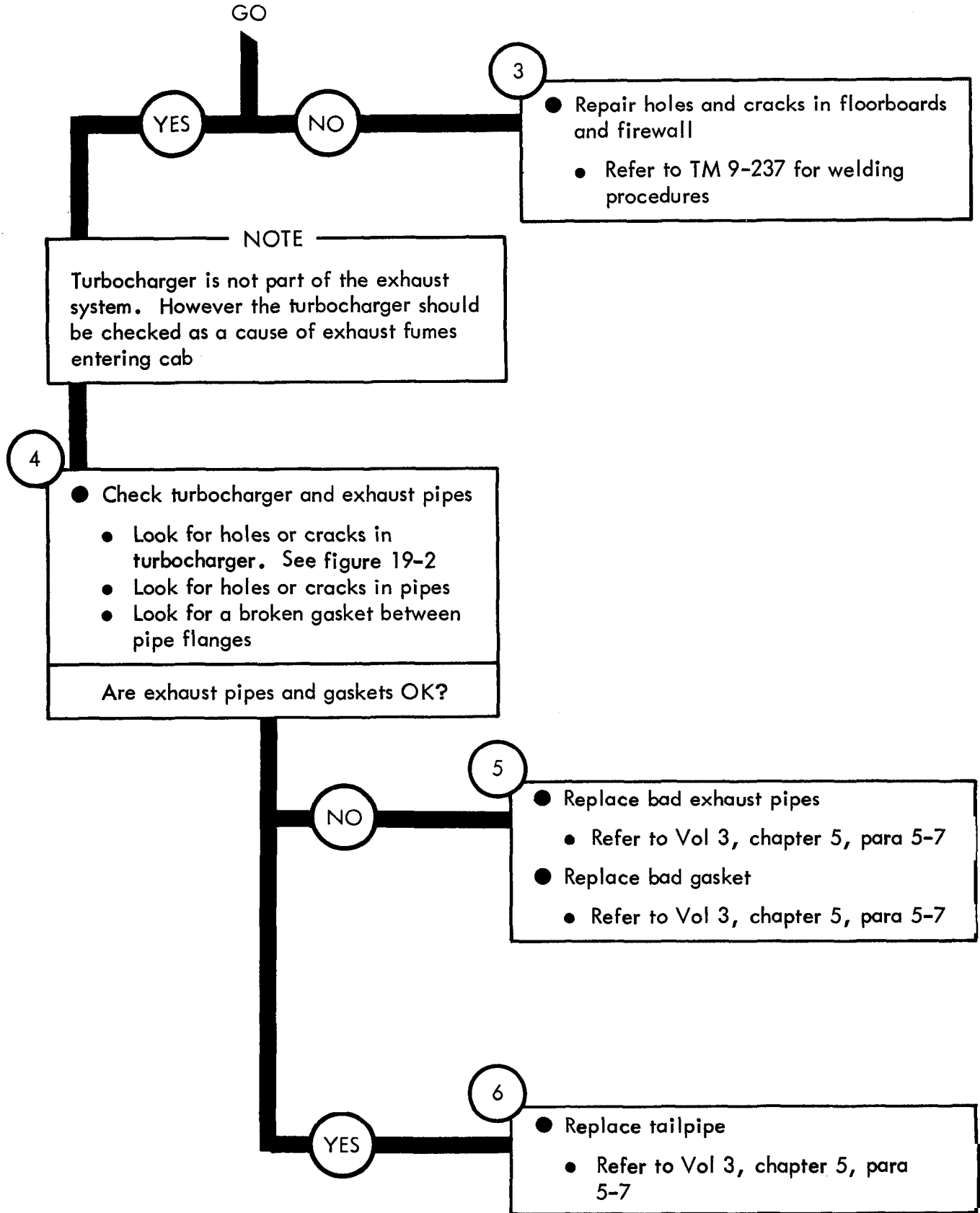

Figure 17-8 (Sheet 2 of 2)

Symptom

9 EXHAUST SYSTEM MAKES NOISE ON TRUCKS M50A1, M50A2, AND M50A3

- 1
- Make truck ready for work on exhaust system
 - Park truck. Refer to TM 9-2320-209-10
 - Chock wheels

— WARNING —

Do not touch any part of the exhaust system while engine is running. You can get badly burned. If the engine has just been shut off, wait until the exhaust system has time to cool down before doing any work

— NOTE —

Exhaust manifold is not part of the exhaust system group. However the exhaust manifold should be checked as a cause of the exhaust system making noise

- 2
- Check exhaust manifold
 - Look for holes or cracks. See figure 19-5
- Is exhaust manifold OK?

GO

Figure 17-9 (Sheet 1 of 3)

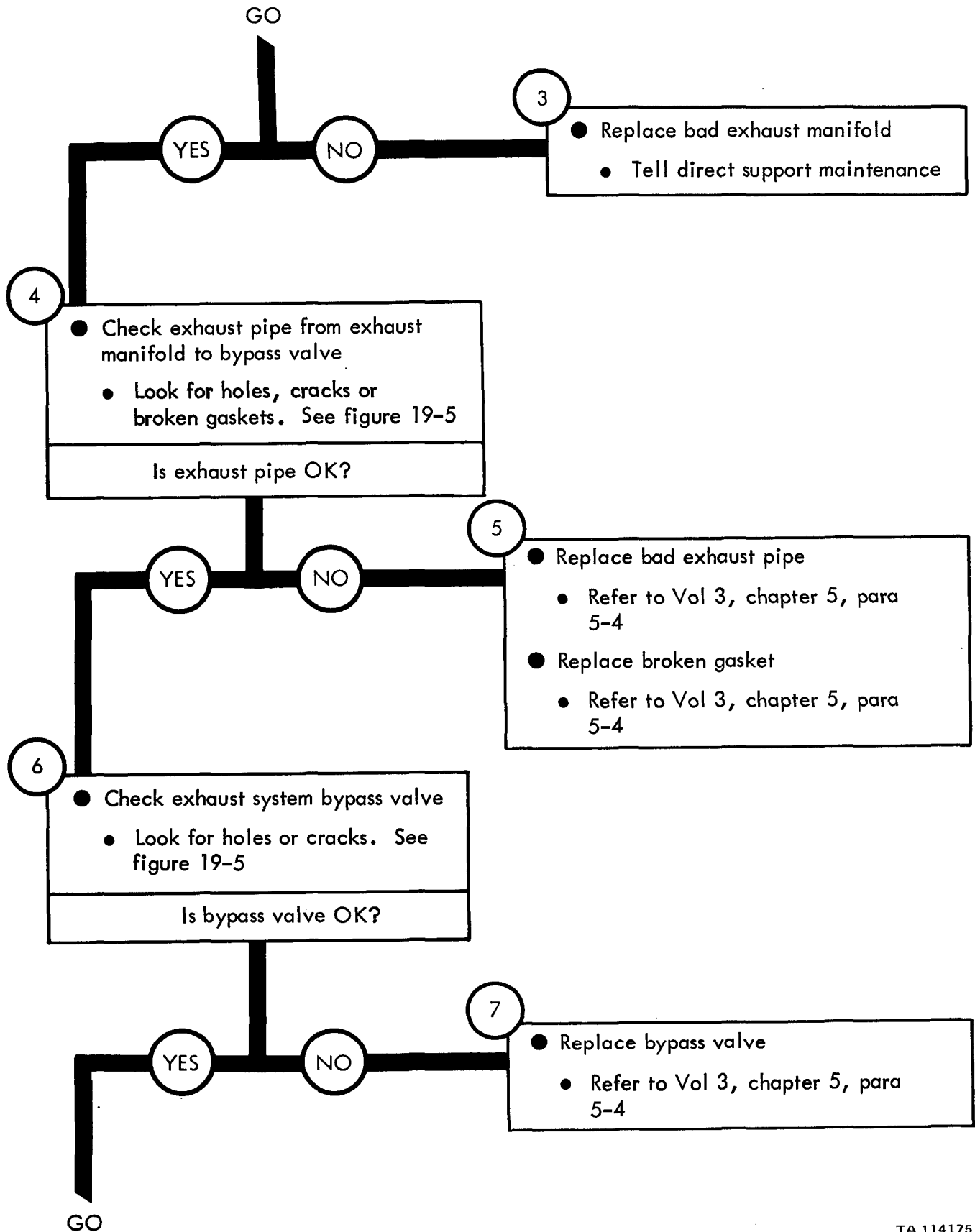

Figure 17-9 (Sheet 2 of 3)

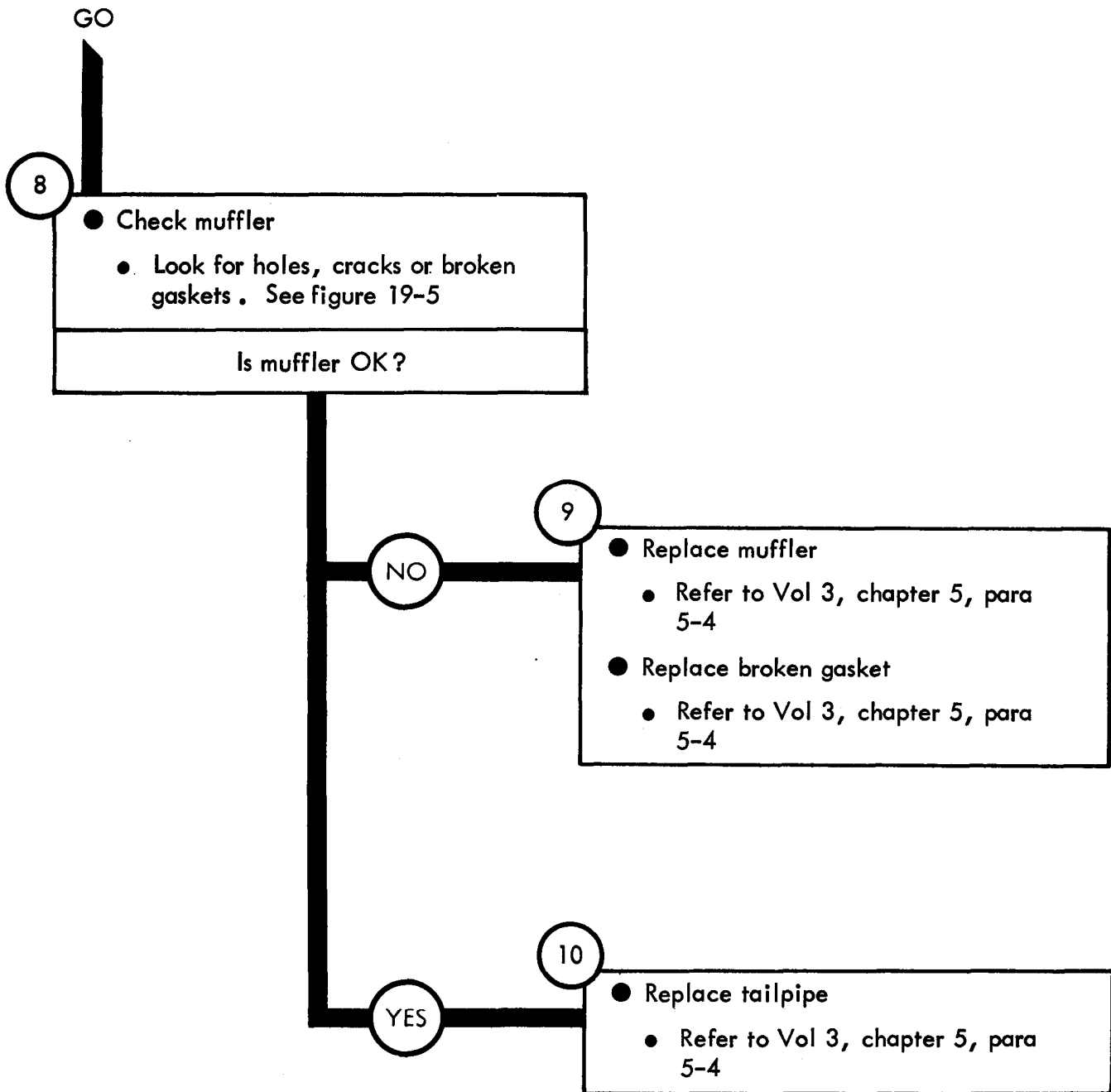

Figure 17-9 (Sheet 3 of 3)

TA 114176

CHAPTER 18

EXHAUST SYSTEM TROUBLESHOOTING SUMMARY

18-1. GENERAL. This chapter gives a summary of troubleshooting procedures given in chapter 17 for the exhaust system.

18-2. PROCEDURES. The summary in this chapter covers all fault symptoms found in the detailed troubleshooting procedures. Chapter 7 outlines a sample troubleshooting procedure. The summary procedures are based on the "what-to-do" portions of the detailed procedures and do not include the "how-to-do-it" instructions. Warnings, cautions, and notes are given where needed.

EXHAUST SYSTEM TROUBLESHOOTING SUMMARY

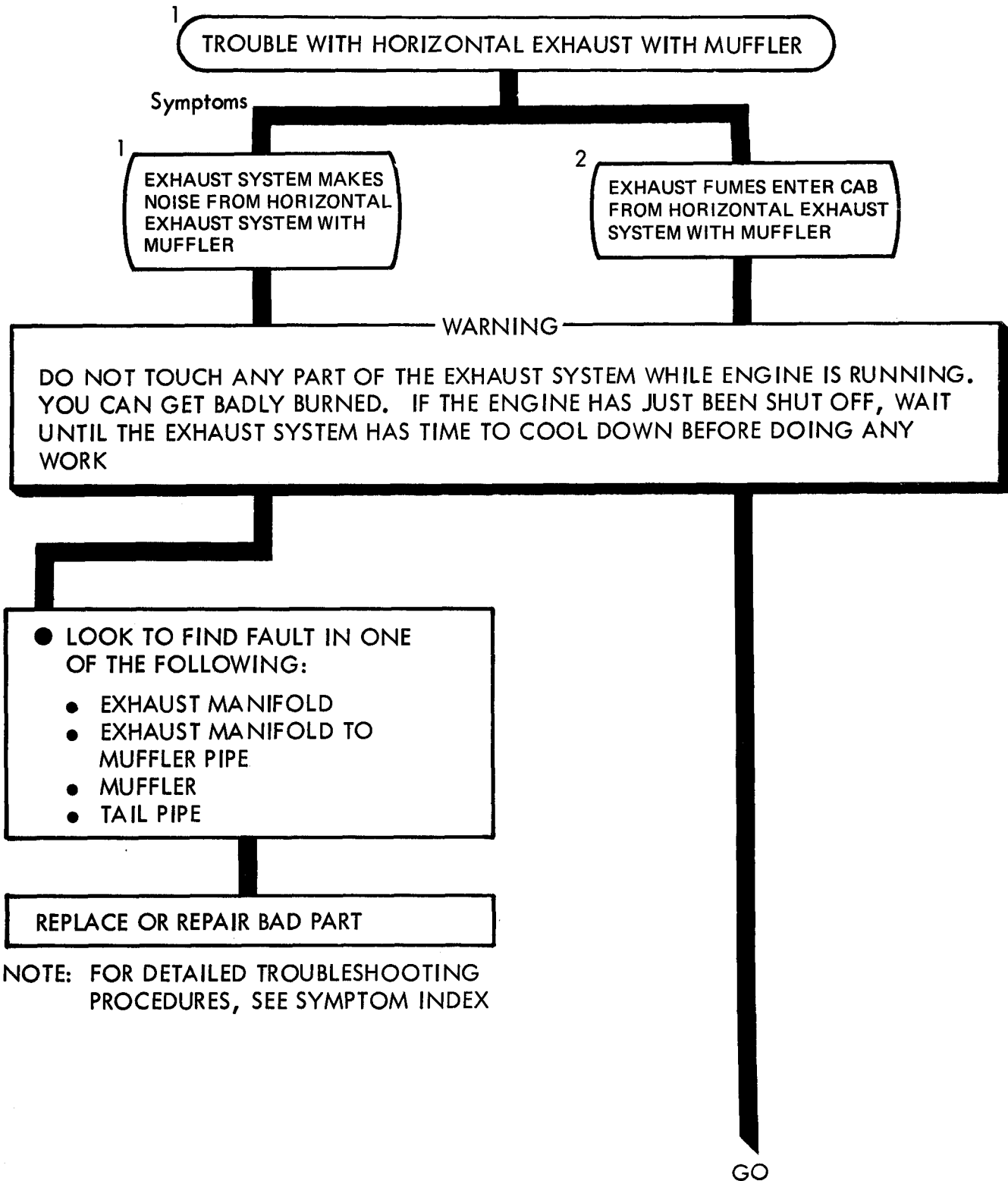
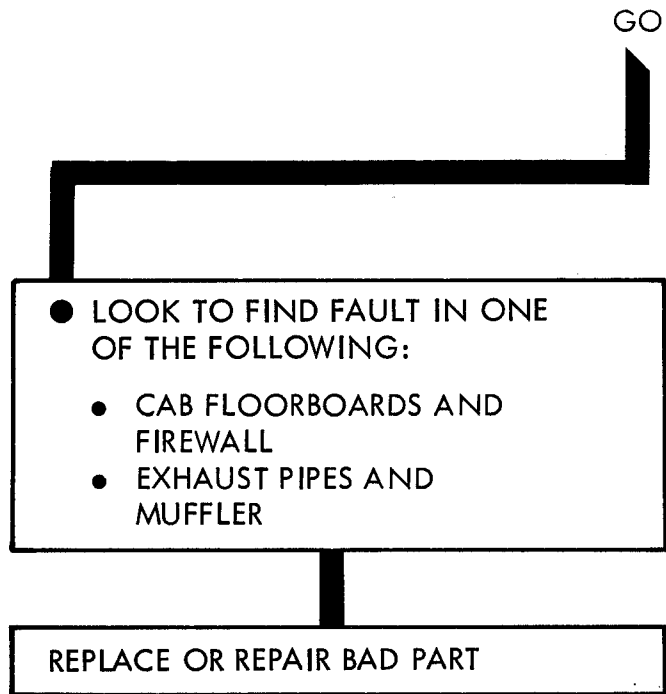

Figure 18-1 (Sheet 1 of 2)



NOTE: FOR DETAILED TROUBLESHOOTING PROCEDURES, SEE SYMPTOM INDEX

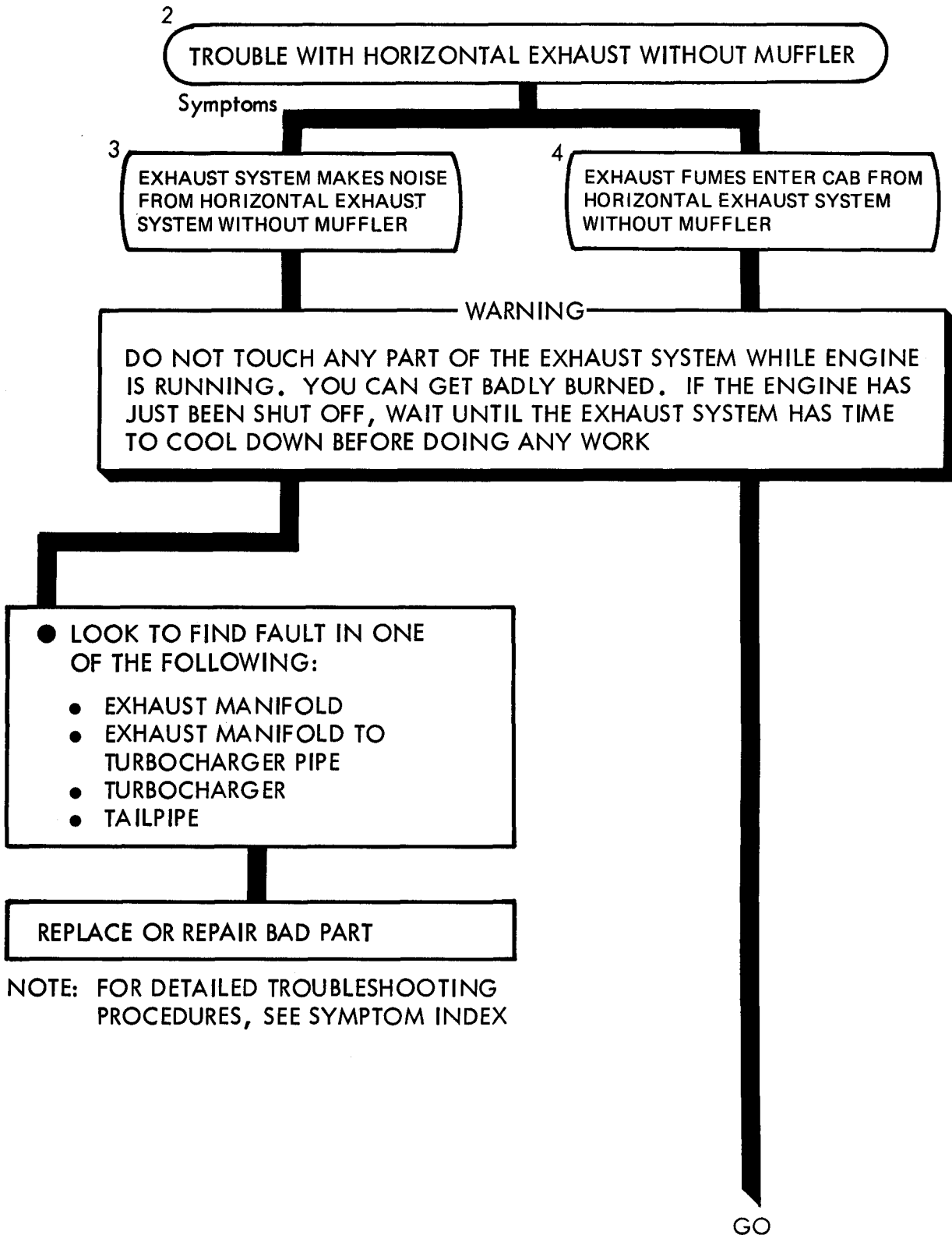
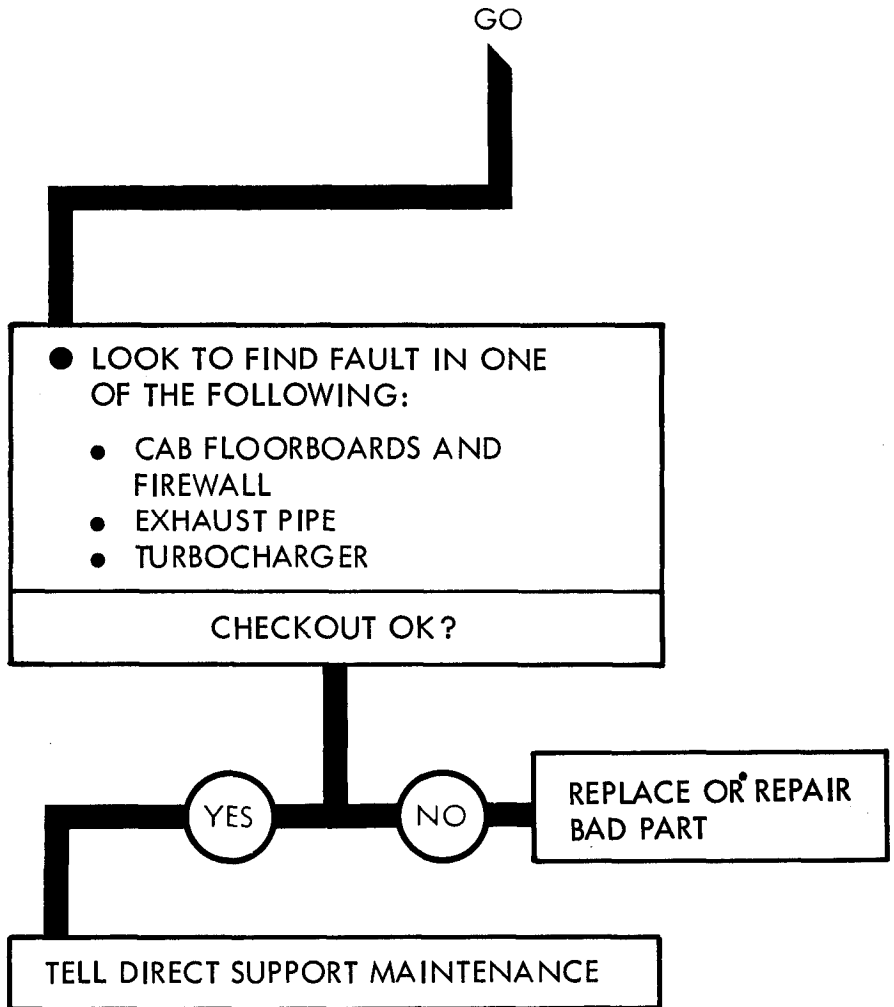
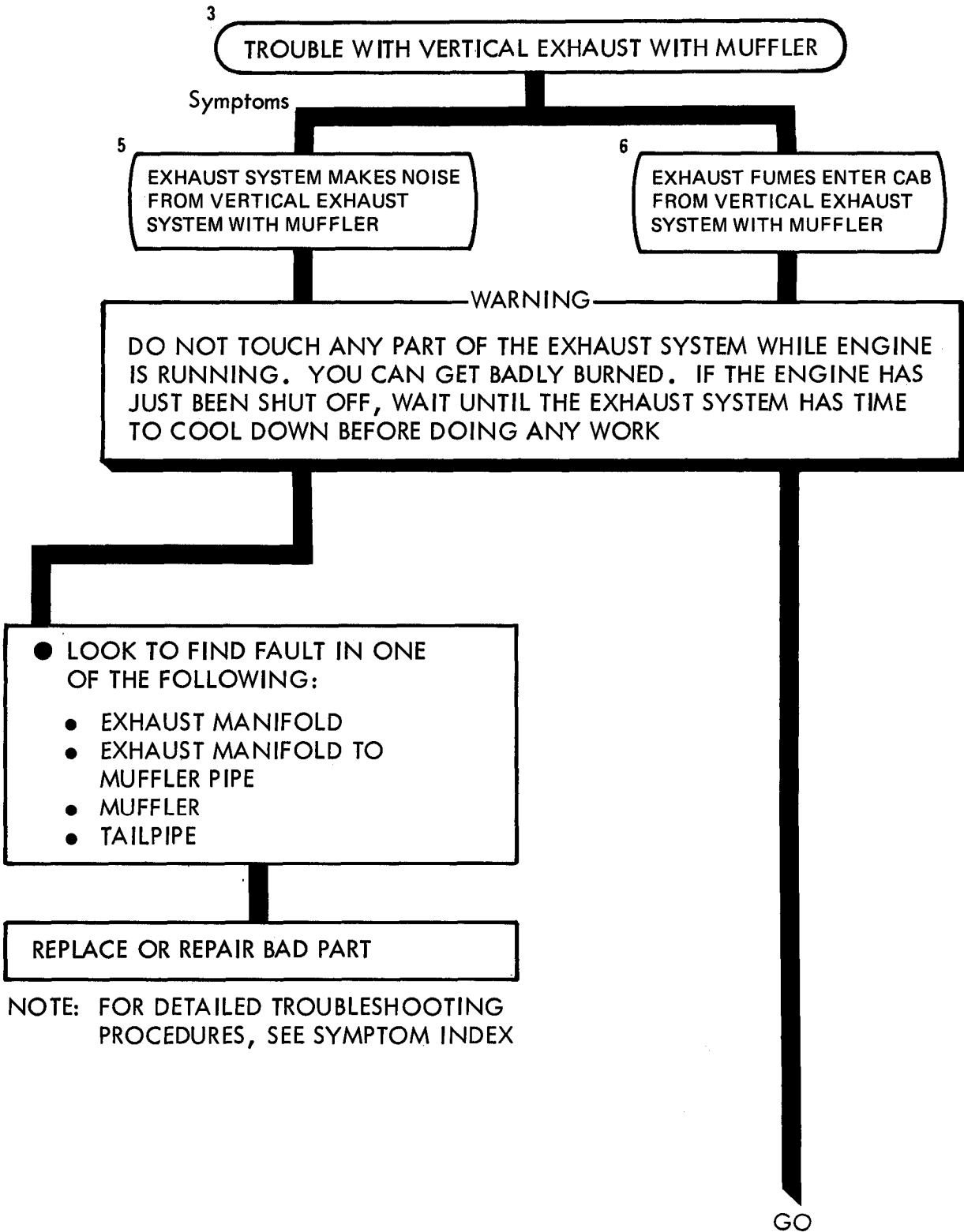

Figure 18-2 (Sheet 1 of 2)



NOTE: FOR DETAILED TROUBLESHOOTING PROCEDURES, SEE SYMPTOM INDEX

Figure 18-2 (Sheet 2 of 2)



TA 114181

Figure 18-3 (Sheet 1 of 2)

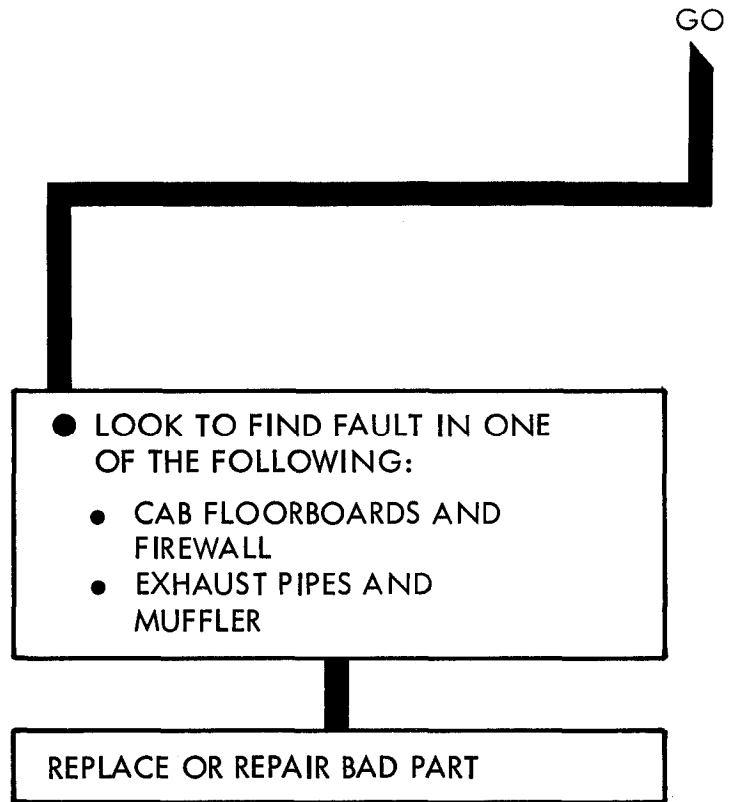

NOTE: FOR DETAILED TROUBLESHOOTING PROCEDURES, SEE SYMPTOM INDEX

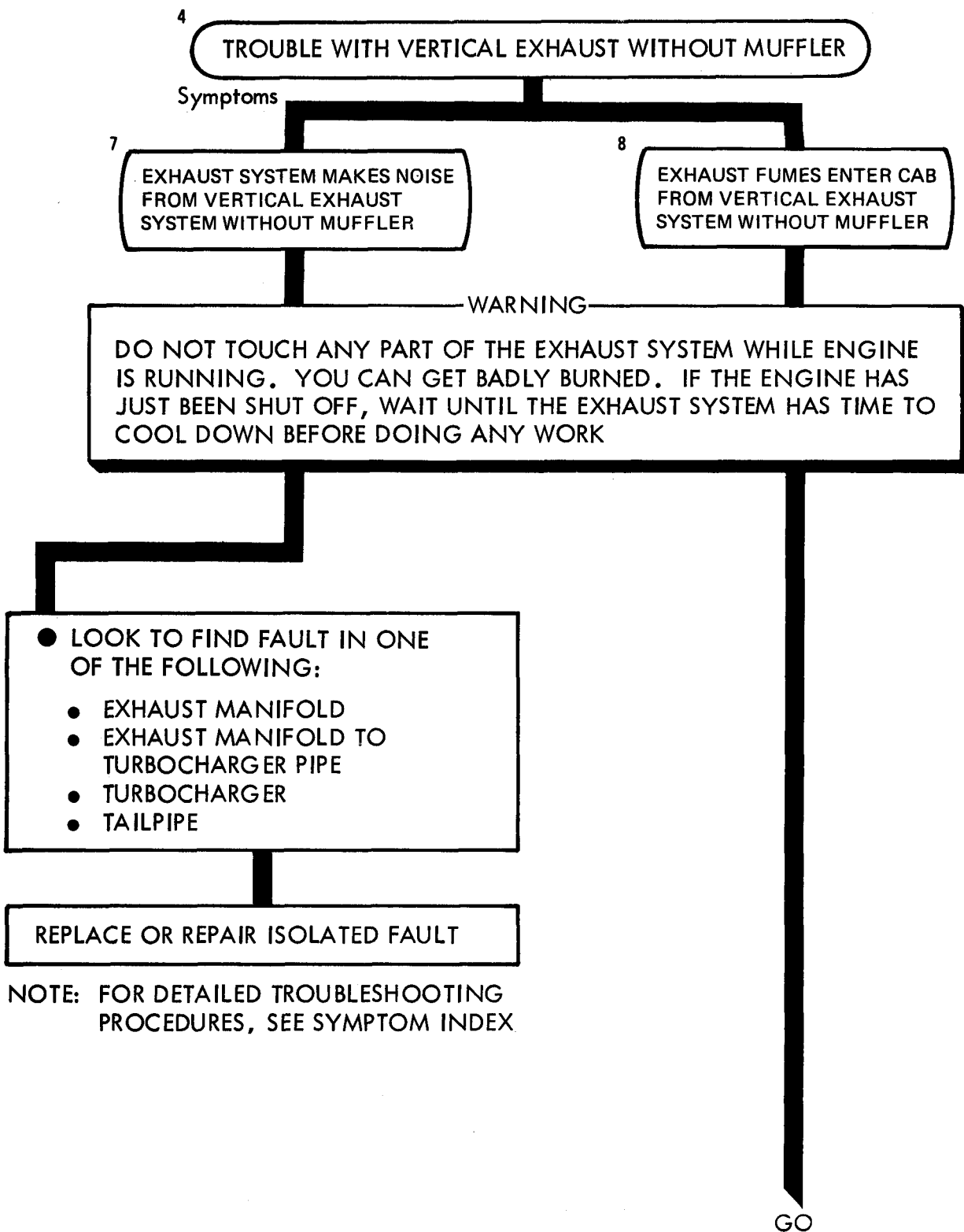
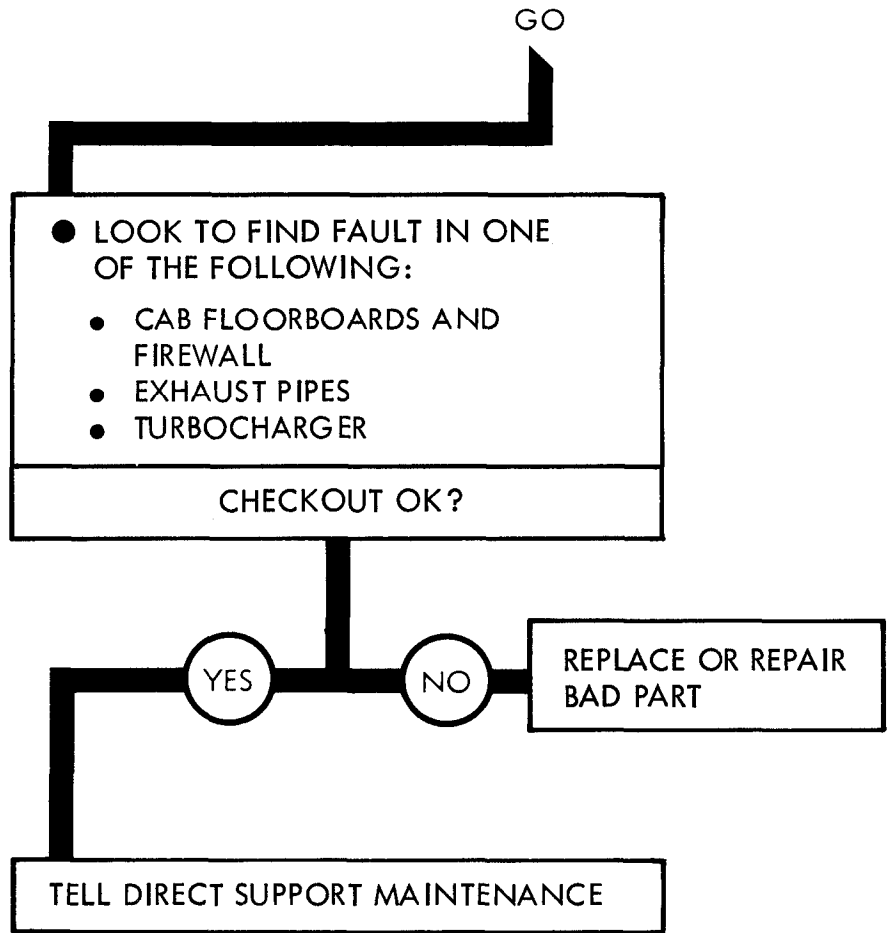

Figure 18-4 (Sheet 1 of 2)

TA 114183



NOTE: FOR DETAILED TROUBLESHOOTING PROCEDURES, SEE SYMPTOM INDEX

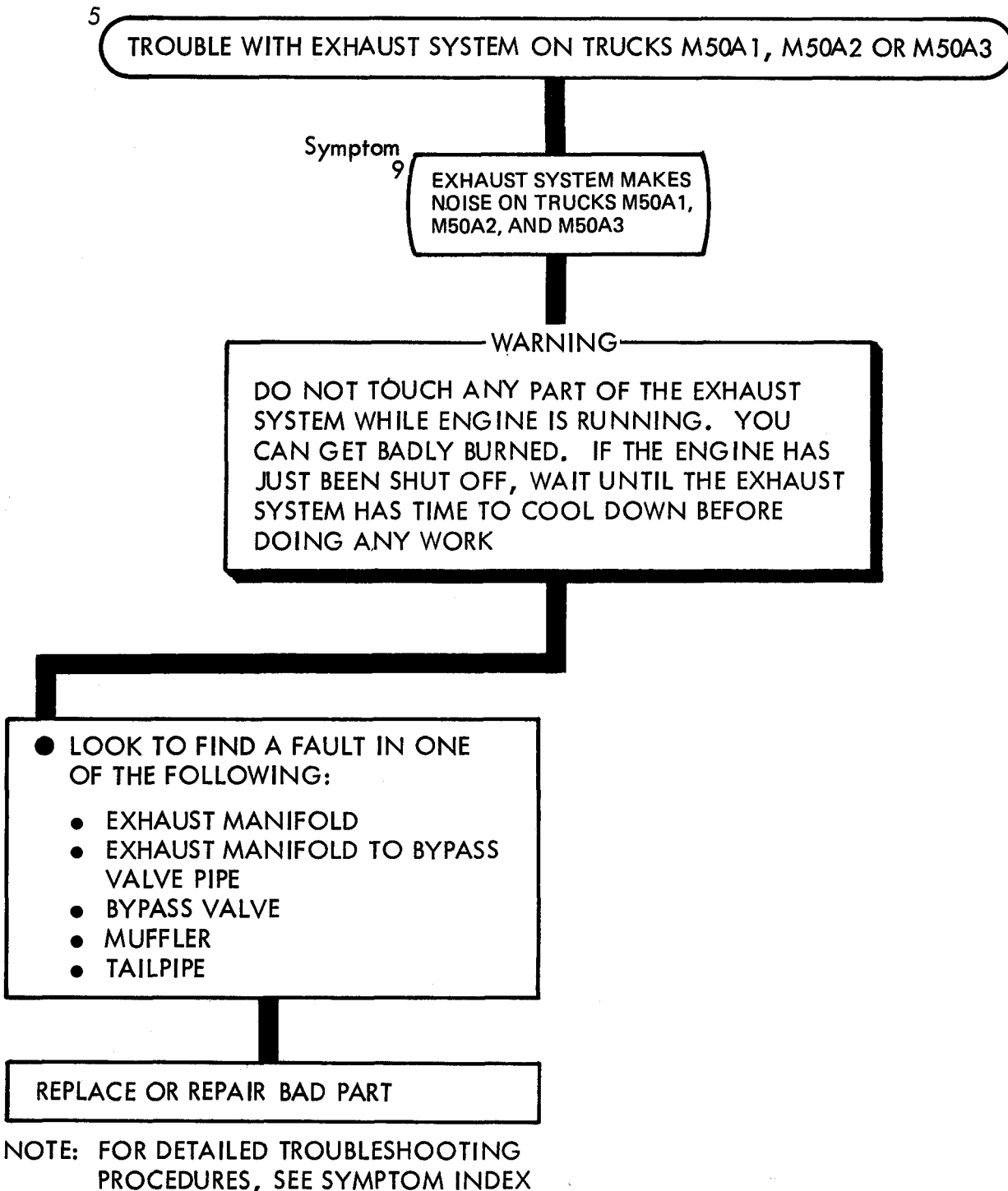

FIGURE 18-5

TA 114185

CHAPTER 19

EXHAUST SYSTEM SUPPORT DIAGRAMS

19-1. GENERAL. This chapter gives the diagrams you need when doing troubleshooting procedures in chapter 17. Table 3-1 is a complete listing of all support diagrams used in this manual.

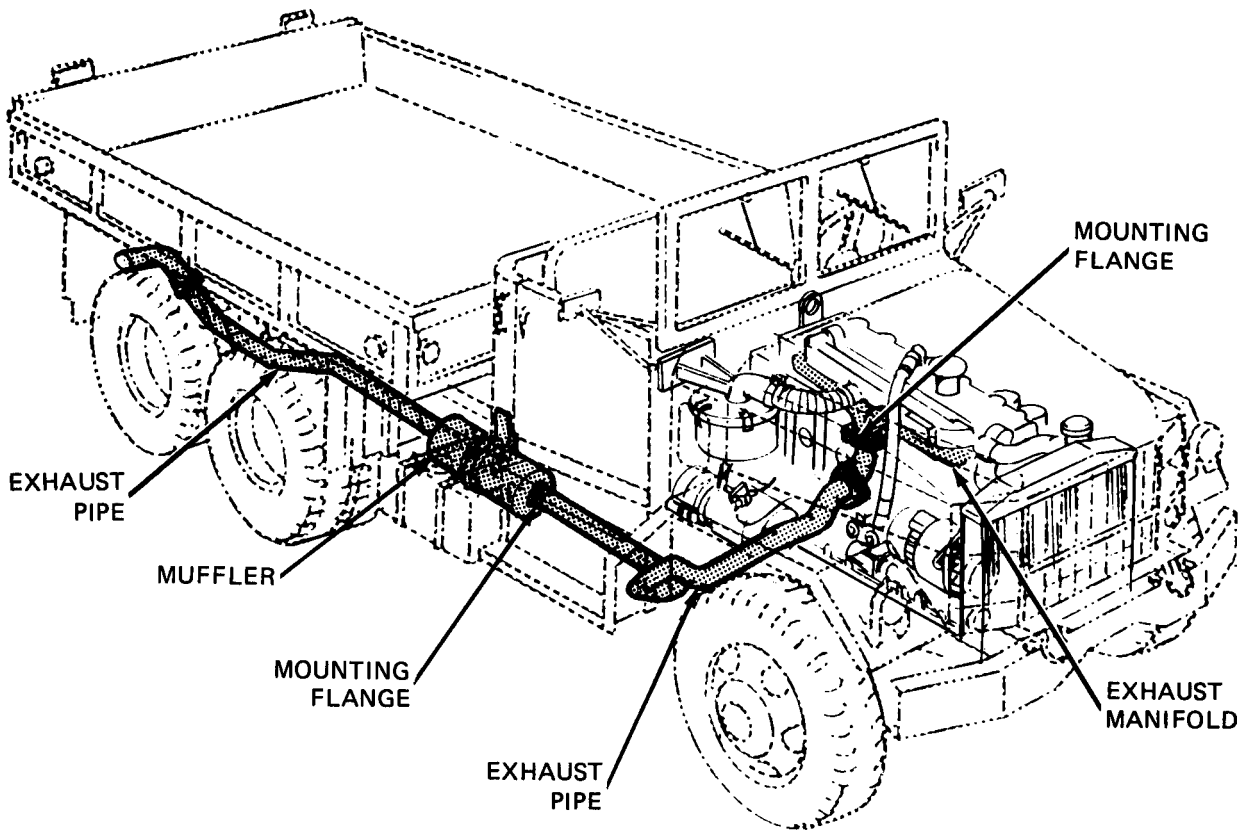

TA 114186

Figure 19-1. Exhaust System Support Diagram

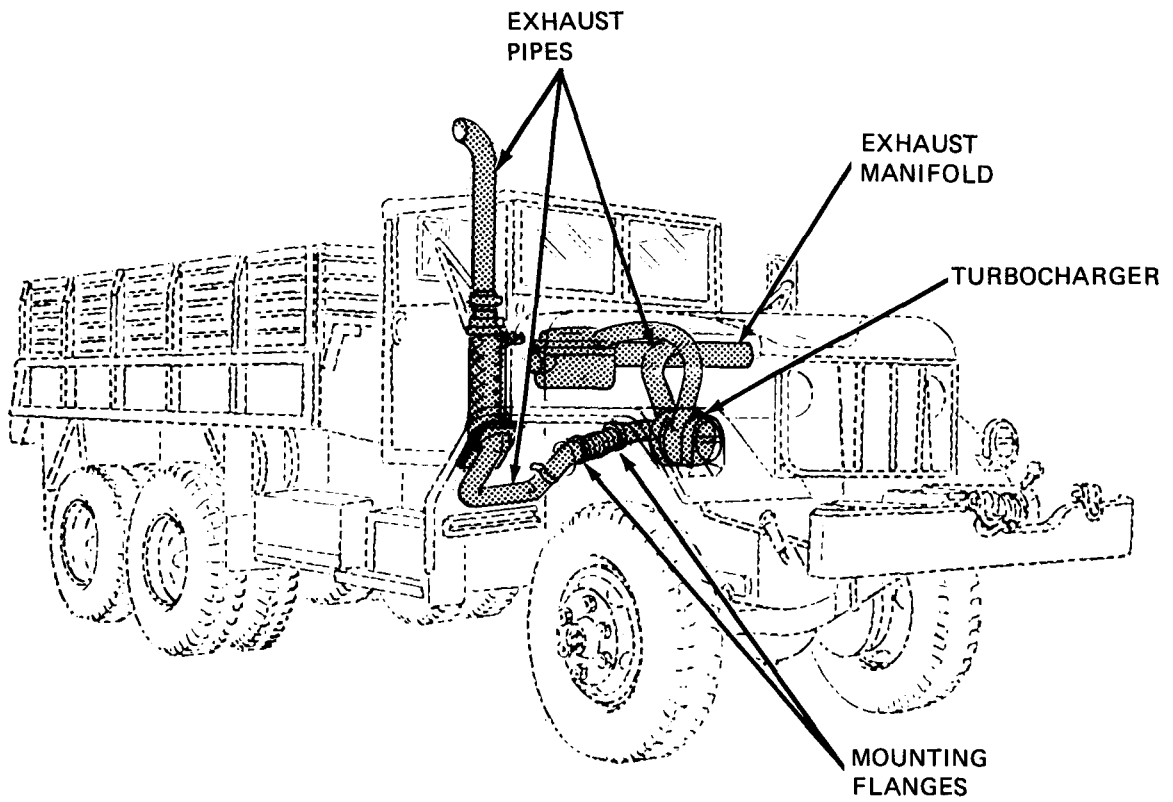

TA 114187

Figure 19-2. Exhaust System Support Diagram

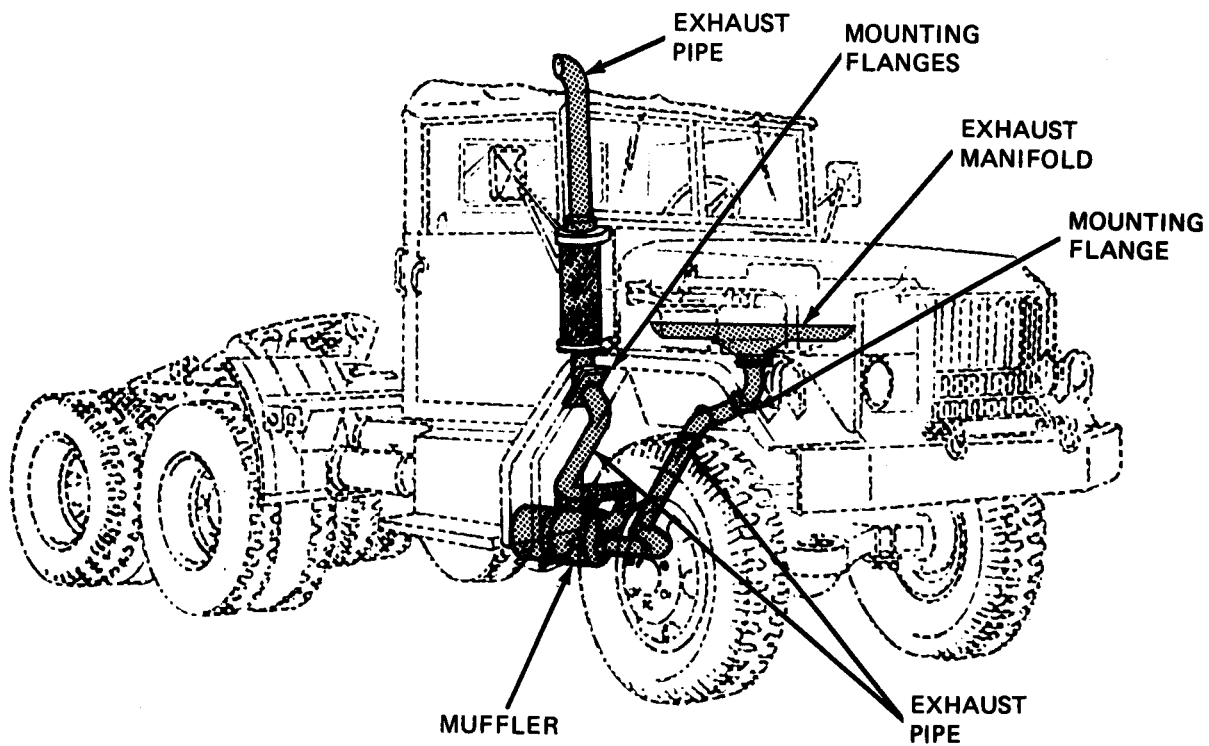

TA 114188

Figure 19-3. Exhaust System Support Diagram

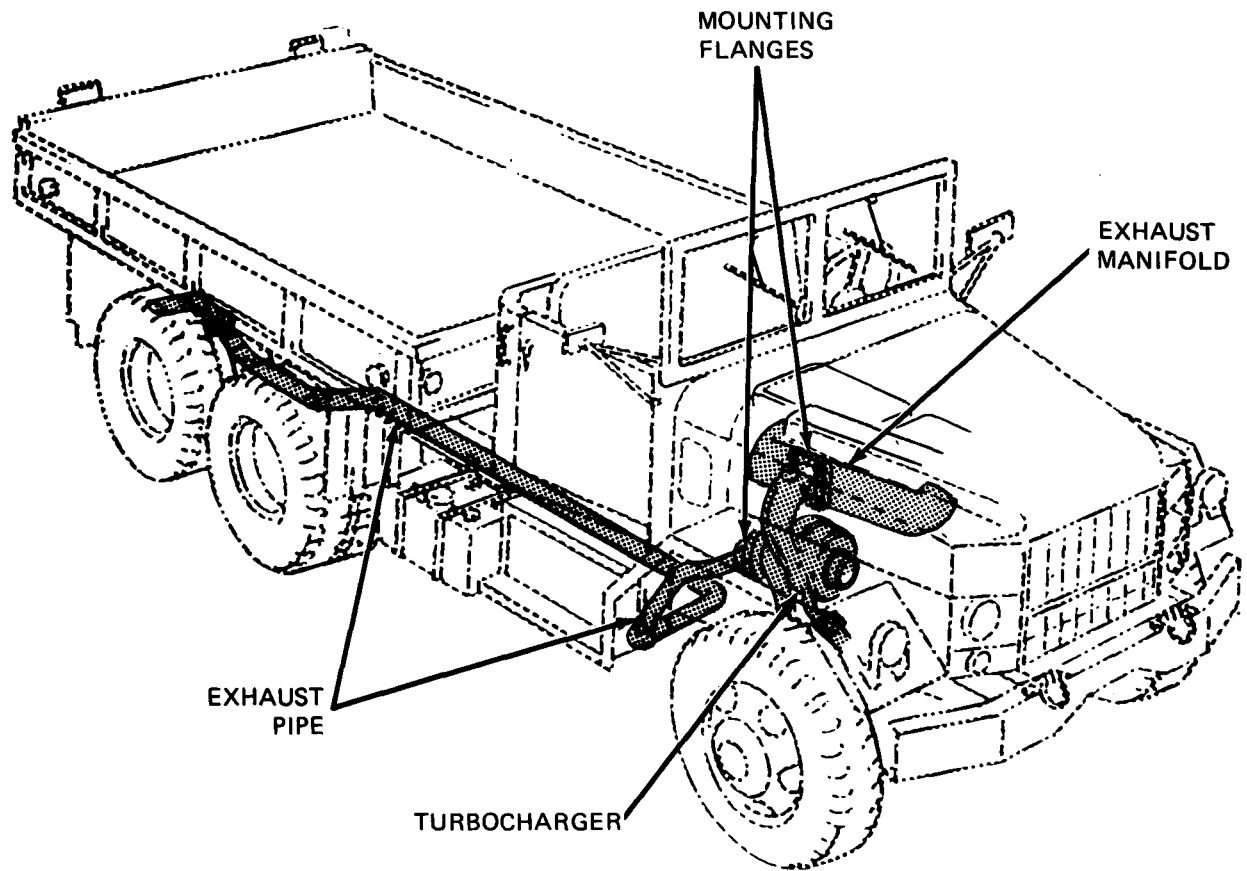

TA 114189

Figure 19-4. Exhaust System Support Diagram

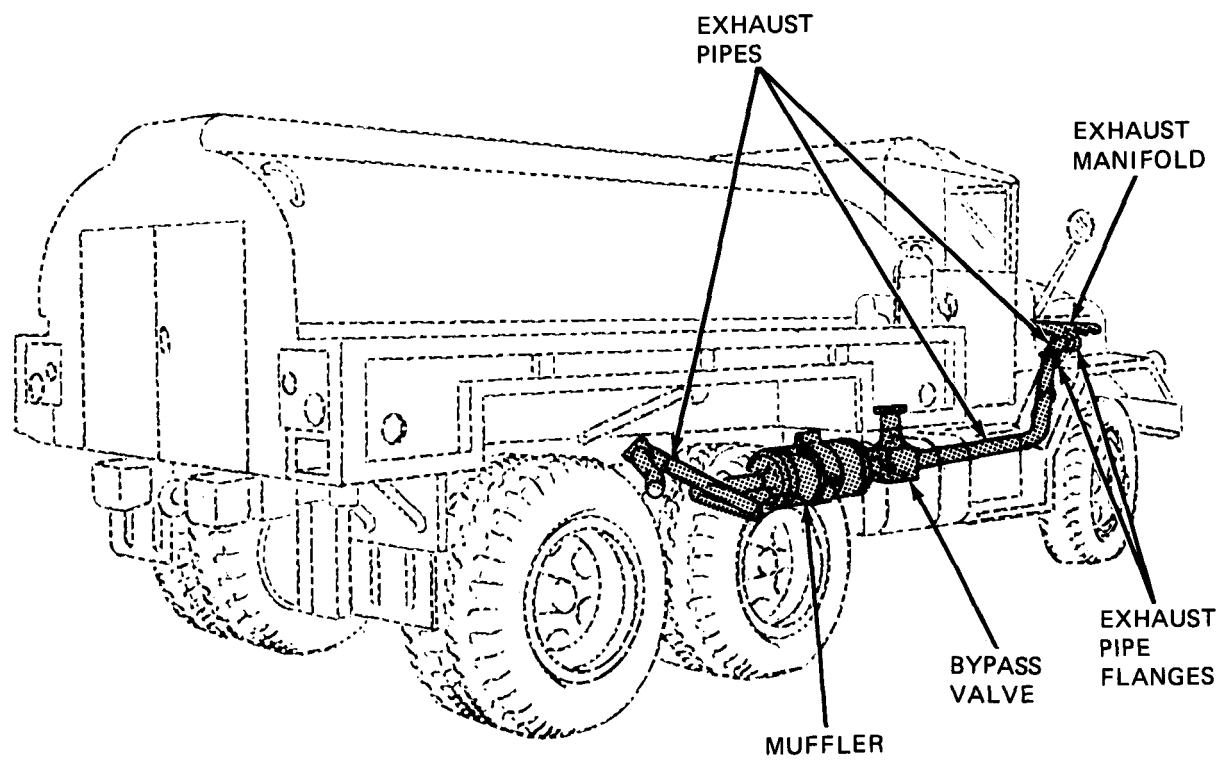

TA 114190

Figure 19-5. Exhaust System Support Diagram

CHAPTER 20

COOLING SYSTEM TROUBLESHOOTING

20-1. EQUIPMENT ITEMS COVERED. This chapter gives equipment troubleshooting procedures for the cooling system, for which there are authorized corrective maintenance tasks at the organizational maintenance level.

20-2. EQUIPMENT ITEMS NOT COVERED. All equipment items for which corrective maintenance is authorized at the organizational maintenance level are covered in this chapter.

COOLING SYSTEM TROUBLESHOOTING

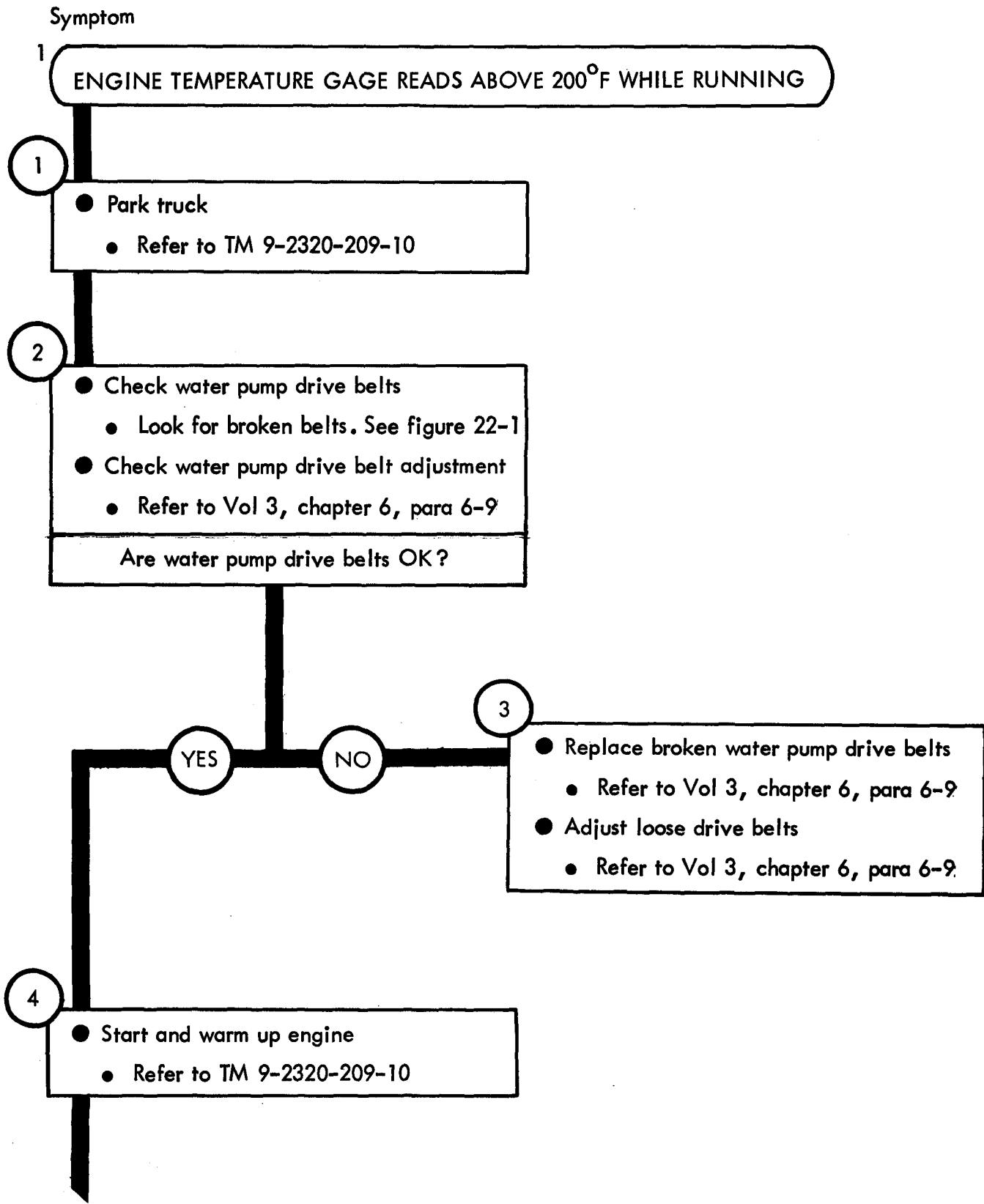

Figure 20-1 (Sheet 1 of 7)

GO

5

- Check water pump
 - See if water pump leaks
- Check upper and lower coolant hoses
 - Look for signs of coolant leaking from hose ends. See figure 22-1
 - Look for bent or crushed hoses
 - Turn off engine. Refer to TM 9-2320-209-10

Are water pump and coolant hoses OK?

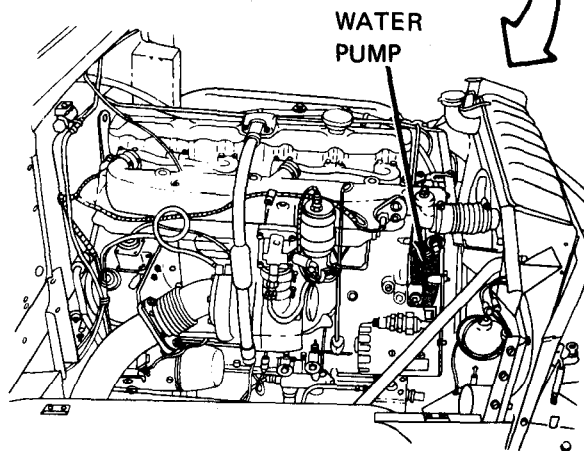
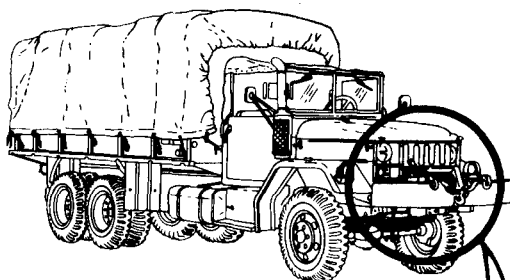

Figure 20-1 (Sheet 2 of 7)

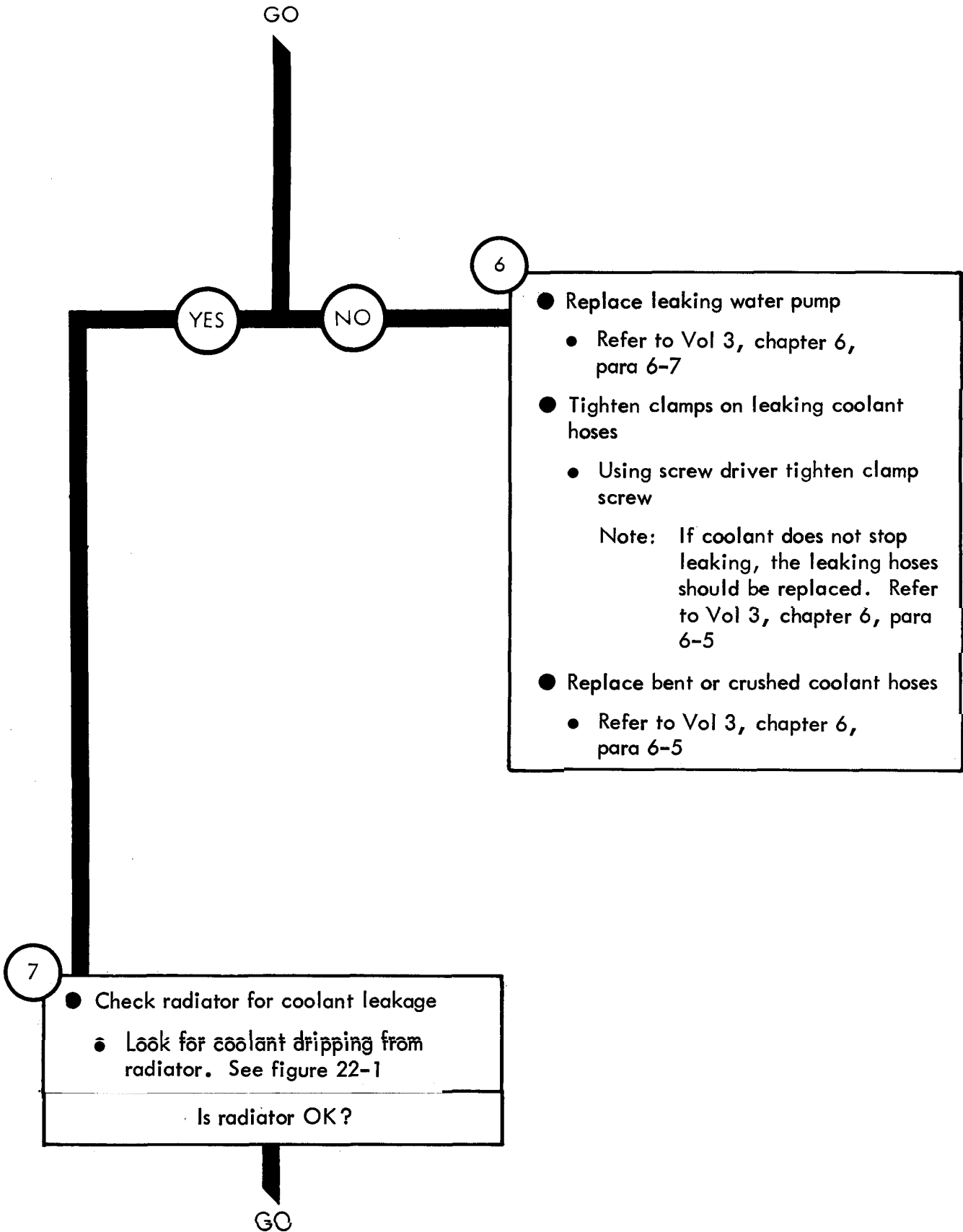

Figure 20-1 (Sheet 3 of 7)

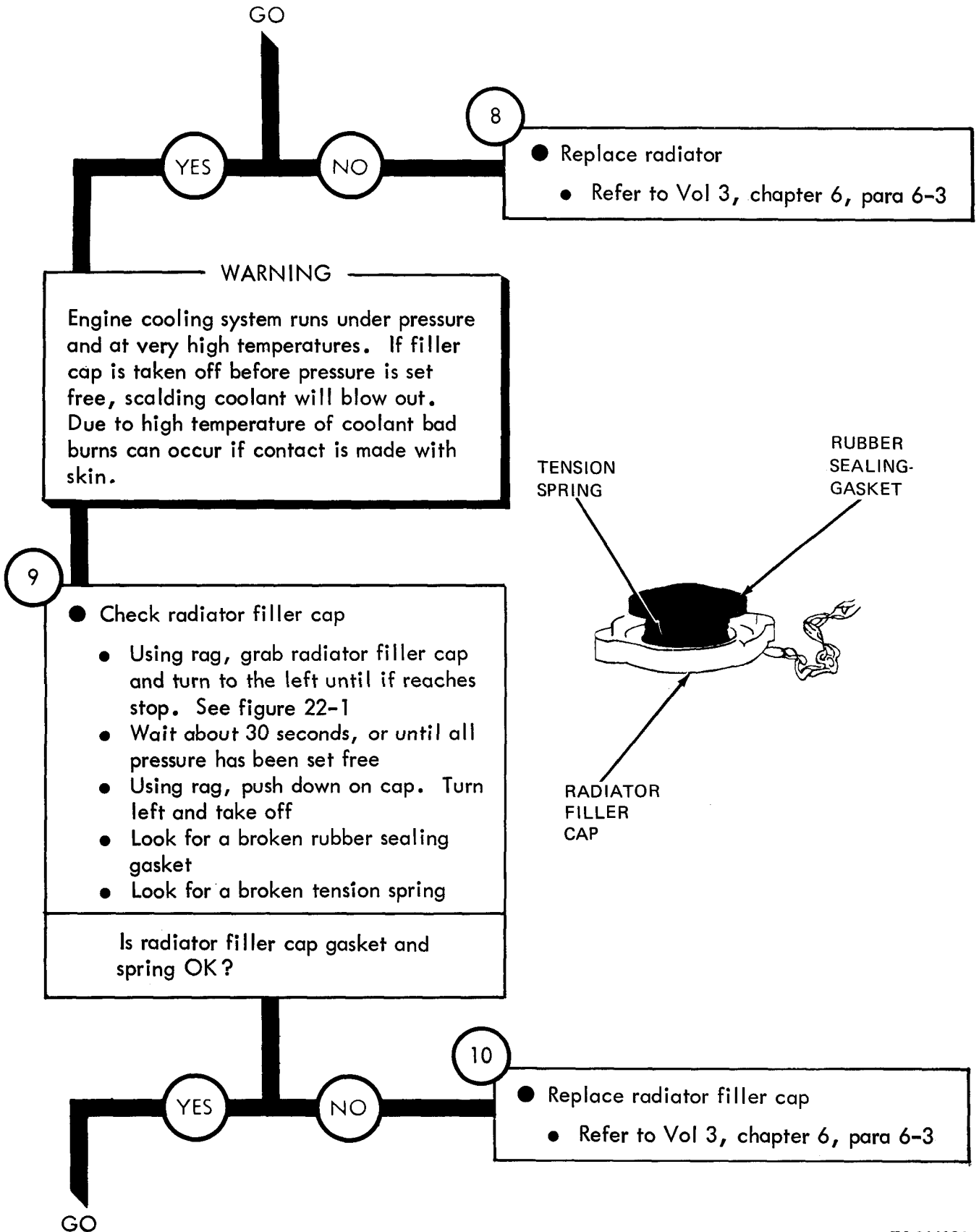

Figure 20-1 (Sheet 4 of 7)

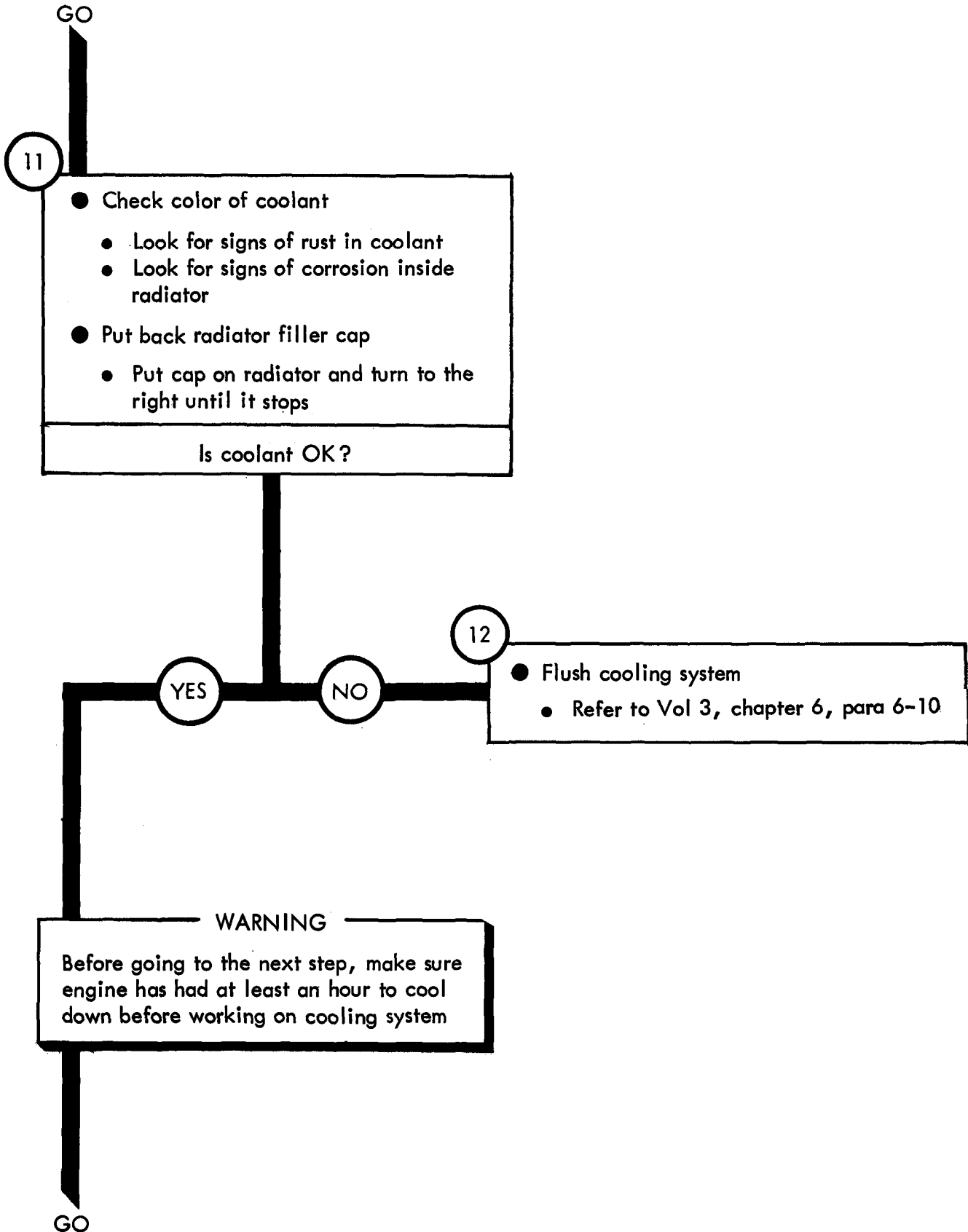

Figure 20-1 (Sheet 5 of 7)

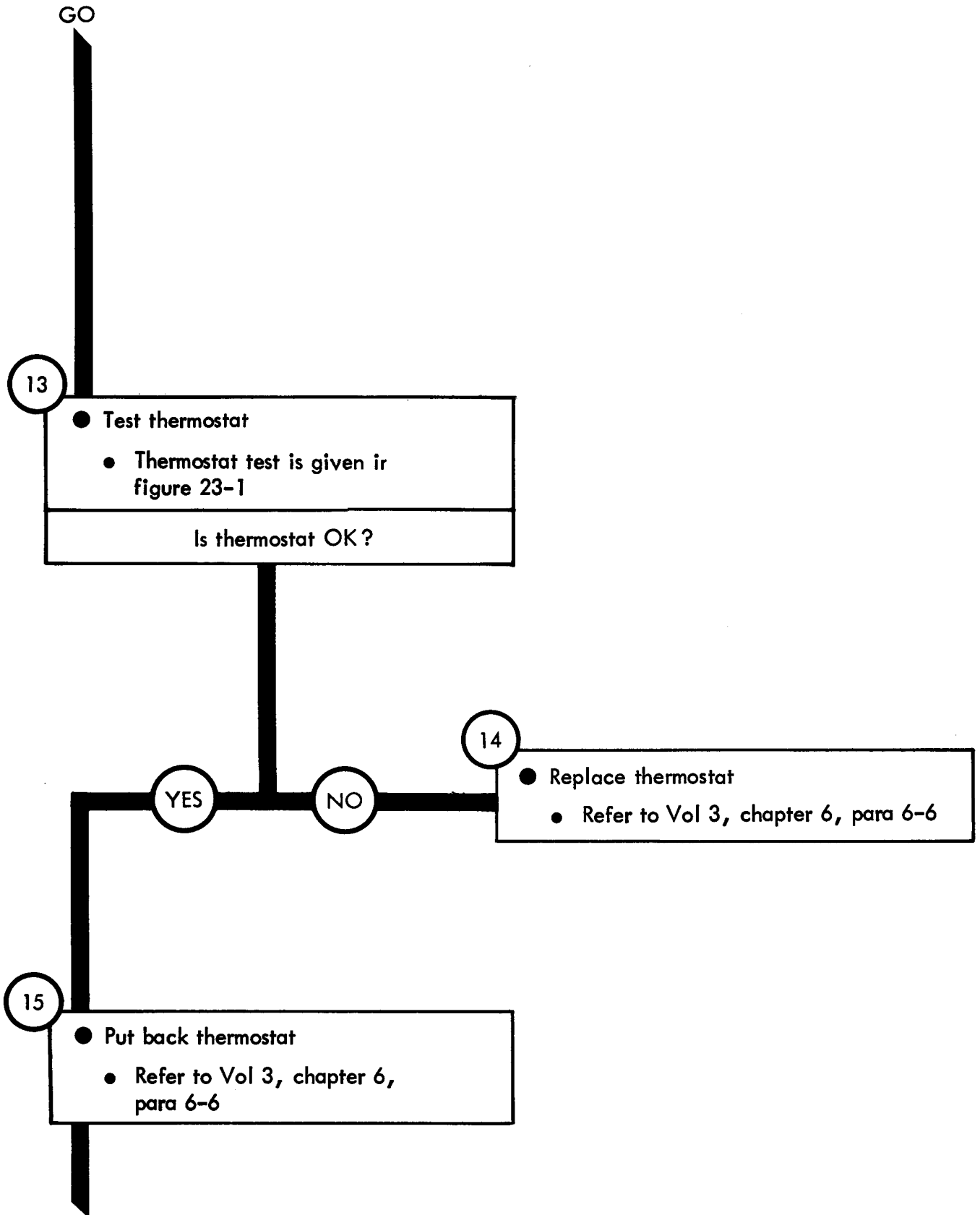

Figure 20-1 (Sheet 6 of 7)

GO

16

- Start and warm up engine
 - Refer to TM 9-2320-209-10
- Do exhaust gas leakage test
 - Pump accelerator pedal lightly three times
 - Using rag, grab radiator filler cap and turn to left until it reaches stop. See figure 22-1
 - Wait about 30 seconds, or until all pressure has been set free
 - Using rag, push down on radiator filler cap, turn to left and take off
 - Look for bubbles in radiator

Is coolant free of bubbles?

NO

17

- Put back radiator filler cap
 - Put radiator filler cap on radiator and turn to right until it stops
- Take off and inspect head
 - Tell direct support maintenance

YES

18

- Put back radiator filler cap
 - Put radiator filler cap on radiator and turn to right until it stops
- Flush cooling system
 - Refer to Vol 3, chapter 6, para 6-10

Figure 20-1 (Sheet 7 of 7)

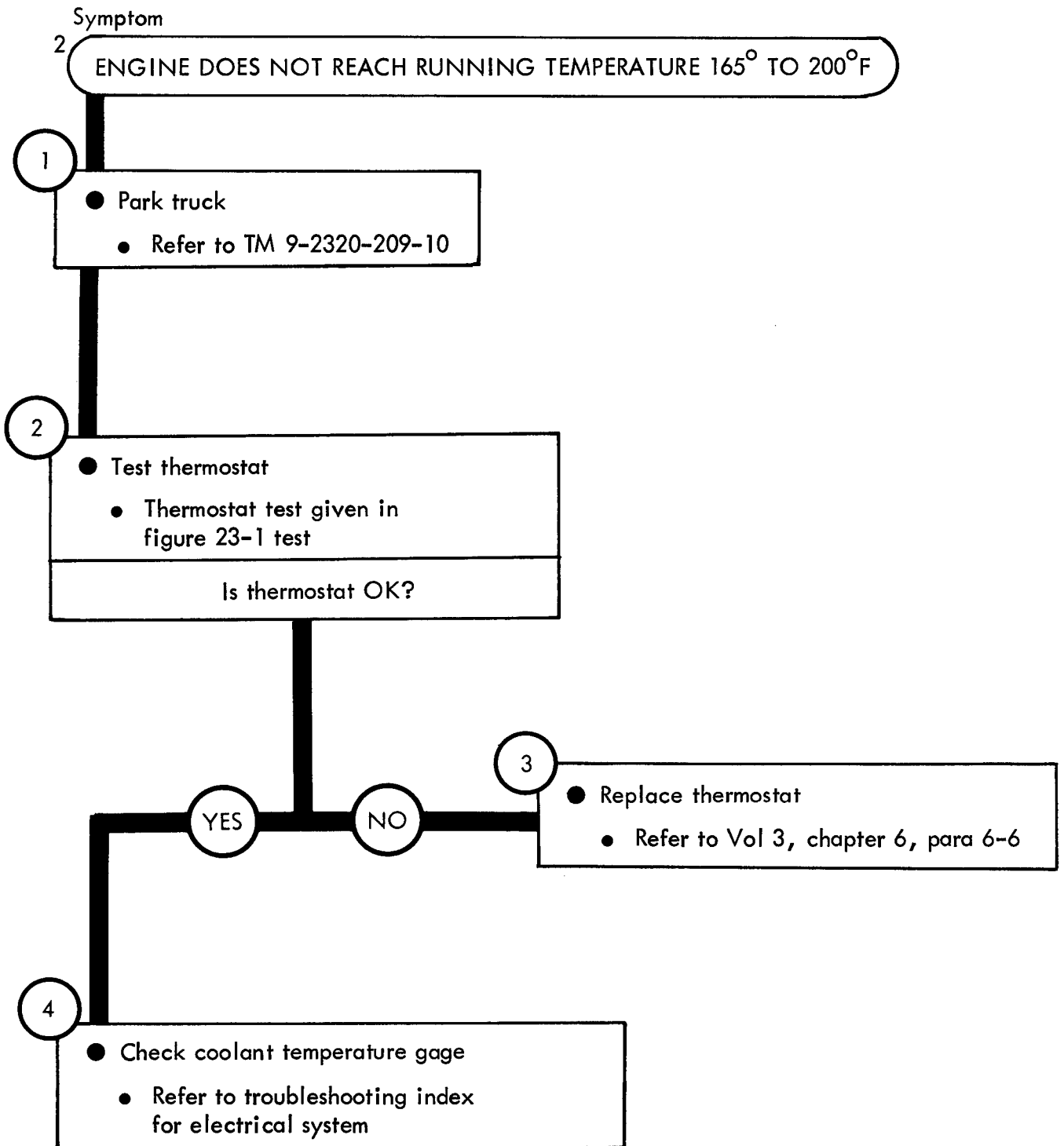

Figure 20-2

Symptom

3 NOISE COMING FROM ENGINE OTHER THAN THAT OF NORMAL RUNNING

- 1
- Park truck
 - Refer to TM 9-2320-209-10

WARNING

Take off battery ground cable before working near or touching fan. Refer to Vol 3, chapter 7, para 7-58. This will make sure that the engine will not be started by accident. Also use a rag when touching fan blades because edges on blades may cause cuts

- 2
- Check engine cooling fan assembly
 - Look for bent fan blades
 - Using a thick cloth grab fan and shake to feel if it is loose
- Is engine cooling fan OK?

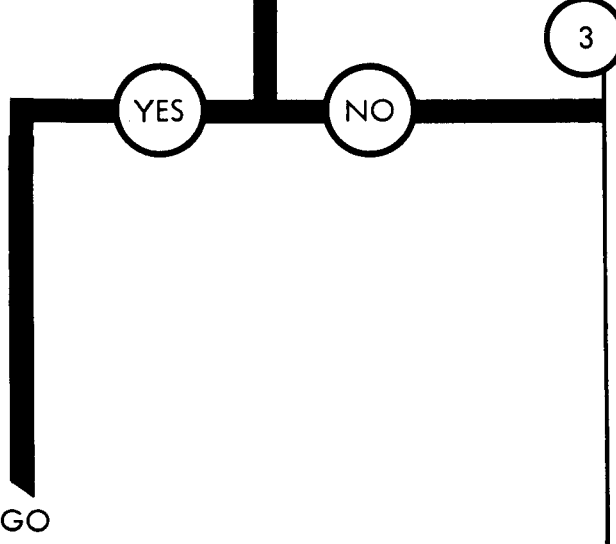
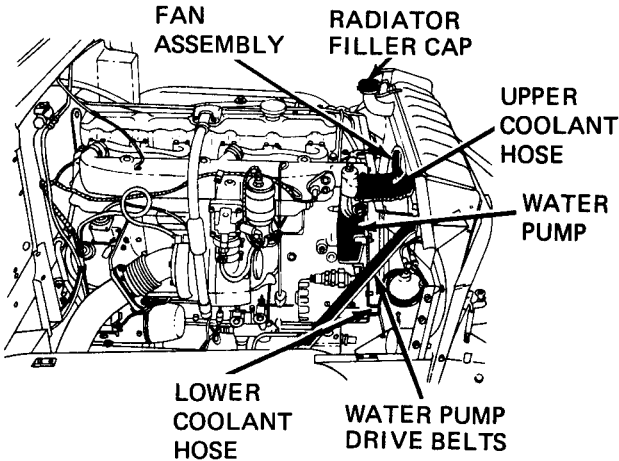

- Replace bent fan blade
 - Refer to Vol 3, chapter 6, para 6-8
 - Tighten engine cooling fan bolts
 - Refer to Vol 3, chapter 6, para 6-8
- Note: Repeat procedure number 1. If fan is still loose replace the water pump. Refer to Vol 3, chapter 6, para 6-7

Figure 20-3 (Sheet 1 of 2)

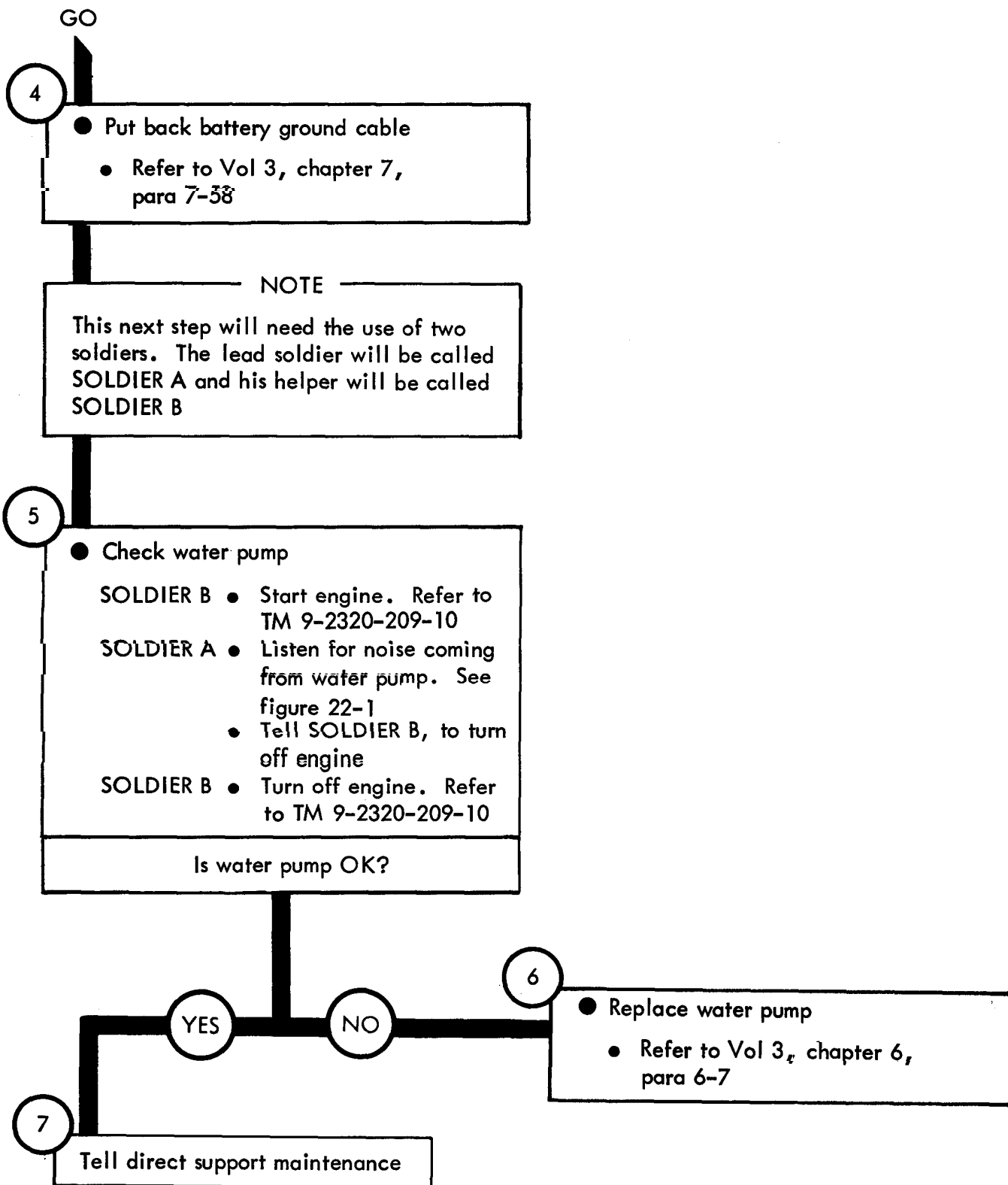

Figure 20-3 (Sheet 2 of 2)

TA 114200

CHAPTER 21

COOLING SYSTEM TROUBLESHOOTING SUMMARY

21-1. GENERAL. This chapter gives a summary of troubleshooting procedures given in chapter 20 for the cooling system.

21-2. PROCEDURES. The summary in this chapter covers all fault symptoms found in the detailed troubleshooting procedures. Chapter 7 outlines a sample troubleshooting procedure. The summary procedures are based on the "what-to-do" portions of the detailed procedures and do not include the "how-to-do-it" instructions. Warnings, cautions, and notes are given where needed.

COOLING SYSTEM TROUBLESHOOTING SUMMARY

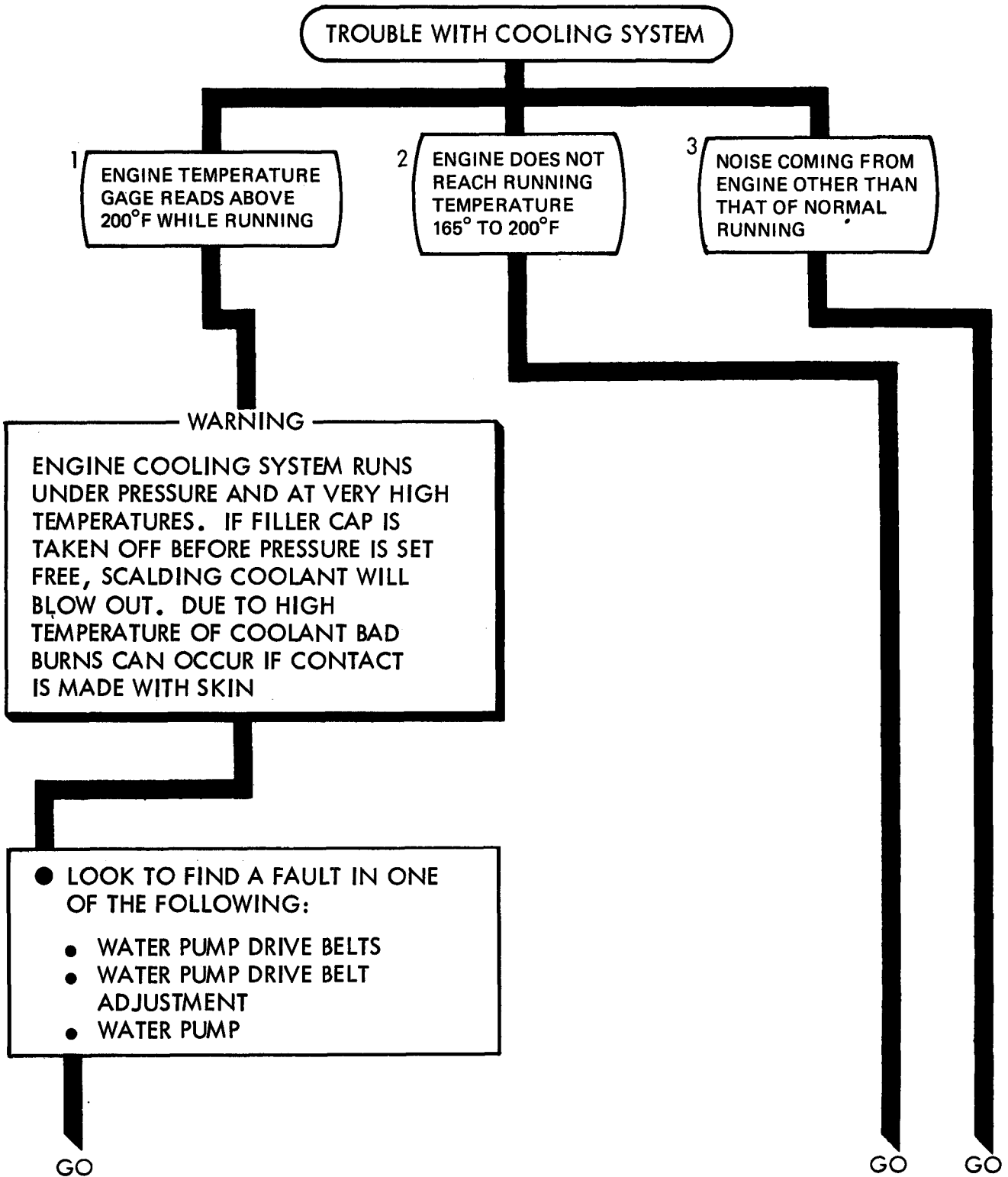

TA 114201

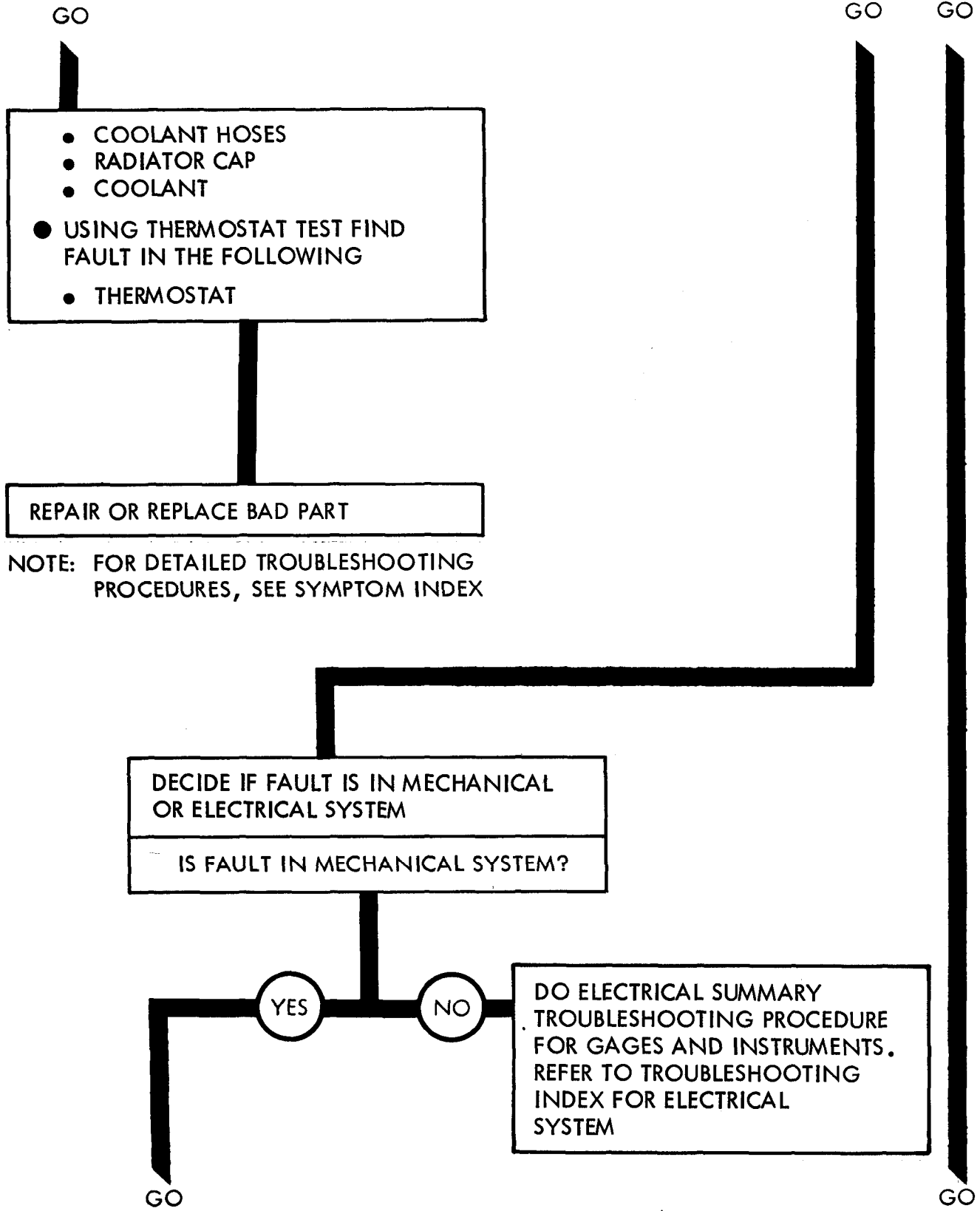

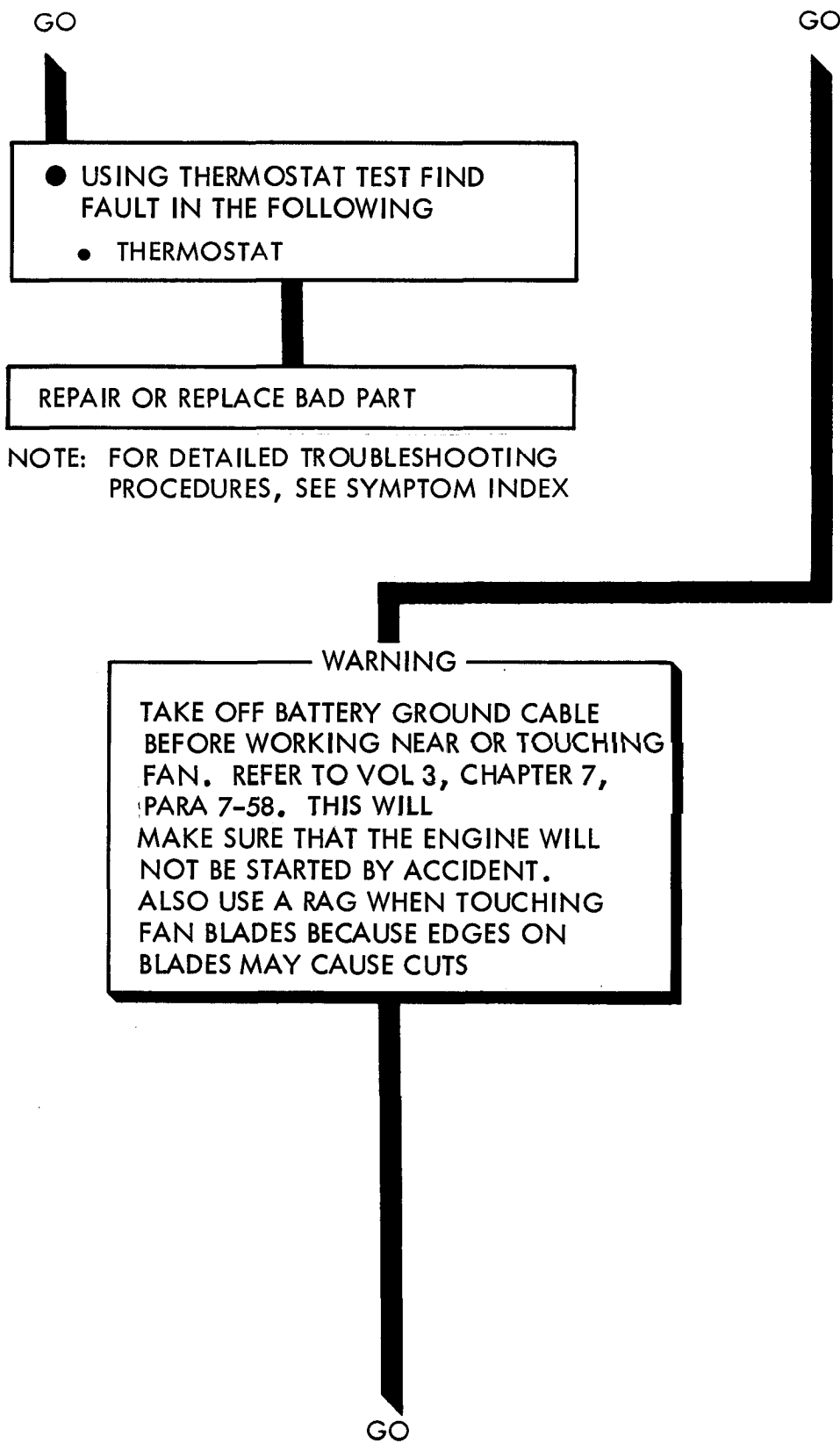

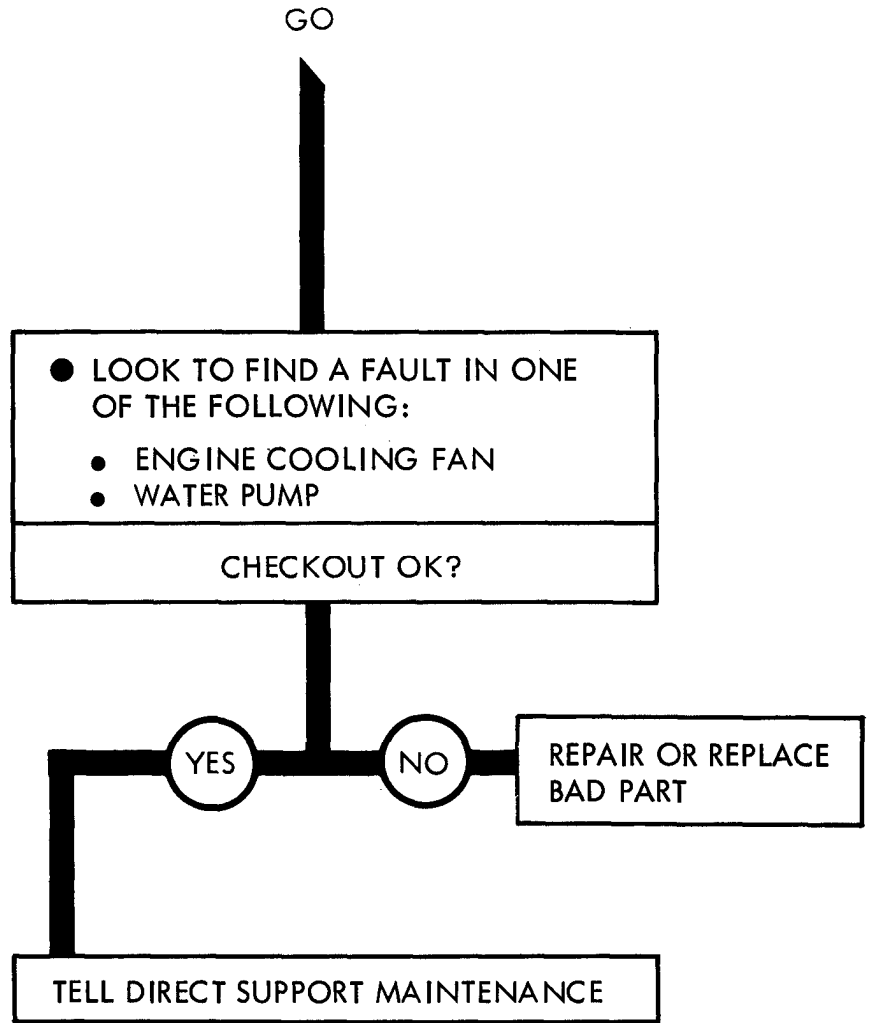

NOTE: FOR DETAILED TROUBLESHOOTING PROCEDURES, SEE SYMPTOM INDEX

CHAPTER 22

COOLING SYSTEM SUPPORT DIAGRAMS

22-1. GENERAL. This chapter gives the diagrams you need when doing troubleshooting procedures in chapter 20. Table 3-1 is a complete listing of all support diagrams used in this manual.

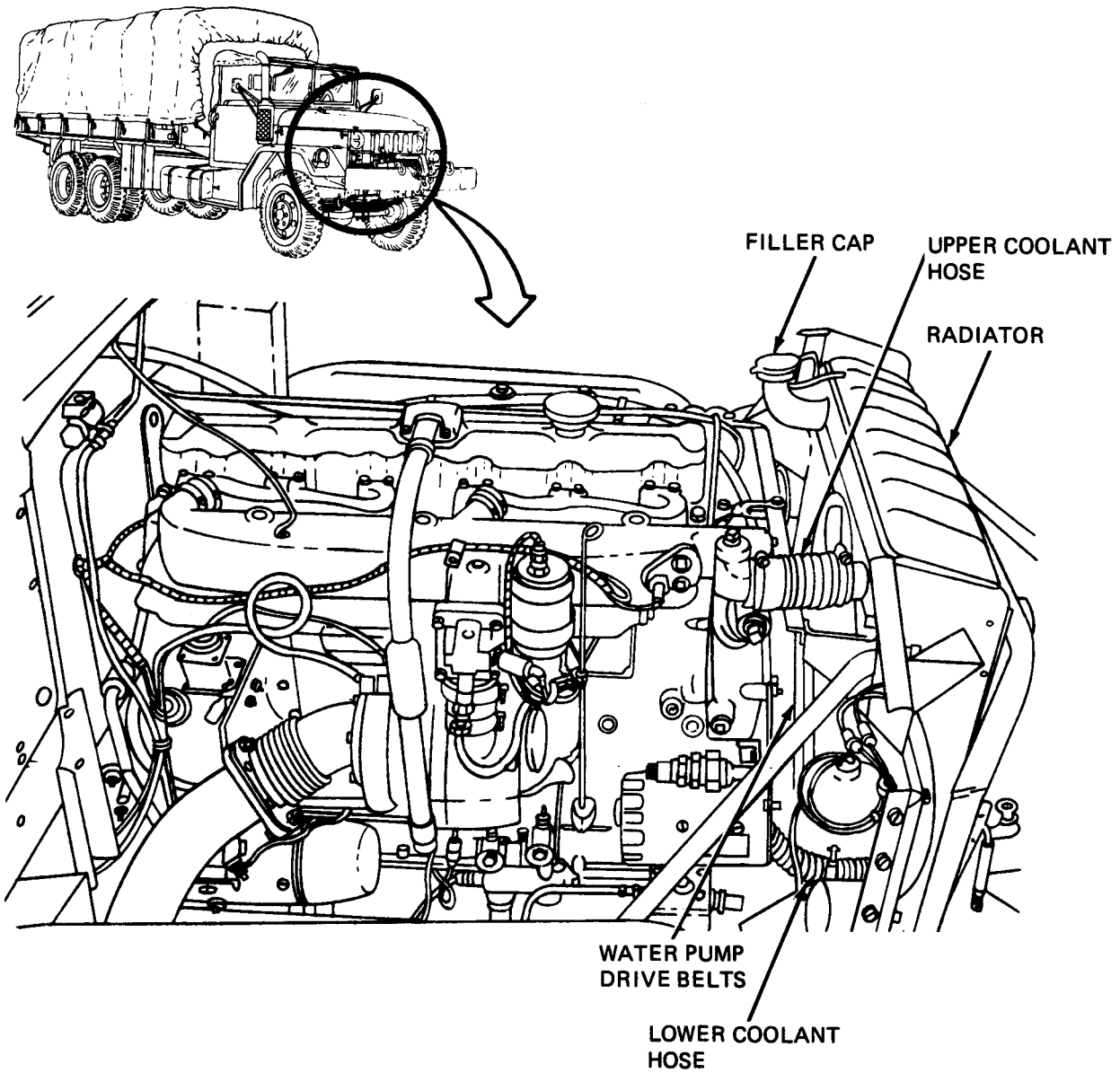

TA 114205

Figure 22-1. Cooling System Support Diagram

CHAPTER 23

COOLING SYSTEM TEST PROCEDURES

23-1. GENERAL. This chapter gives test procedures for the tests given in chapter 20 for the cooling system.

23-2. TEST SET-UP. Instructions for setup of test equipment and parts to be tested are given before the test procedures. Illustrations are used, when needed, to show you how to hook up the test equipment to the part to be tested.

23-3. TEST PROCEDURE. Detailed step-by-step instructions, in flow chart form, are given for each test. The procedure calls out the type of test and the condition of the truck system for each part of testing. The step-by-step test will lead you to the bad component or to a fault symptom within a related system. Reference is made to the fault symptom index, chapter 6, if the test shows a fault in another system.

COOLING SYSTEM TROUBLESHOOTING TEST

THERMOSTAT TEST

- Test thermostat
 - Remove thermostat. Refer to Vol 3, chapter 6, para 6-6
 - Place thermostat in can of water
 - Place thermometer in water
 - Heat water to 180°F and see if thermostat starts to open
 - Heat water to 200°F and see if thermostat is fully open

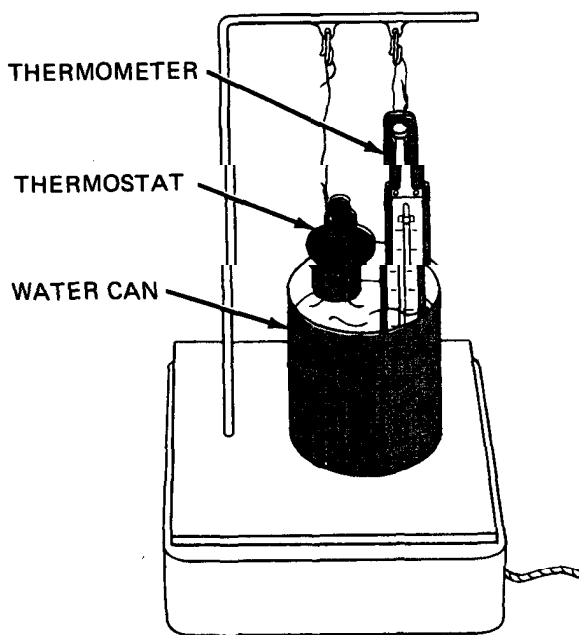

TA 114206

CHAPTER 24

COOLING SYSTEM CHECKOUT PROCEDURES

24-1. GENERAL. This chapter gives procedures for checking out the system after troubleshooting and repair have been done. Procedures are set up in flow chart form showing the checkout steps in order and referring to the fault symptom index when the system does not check out.

COOLING SYSTEM CHECKOUT

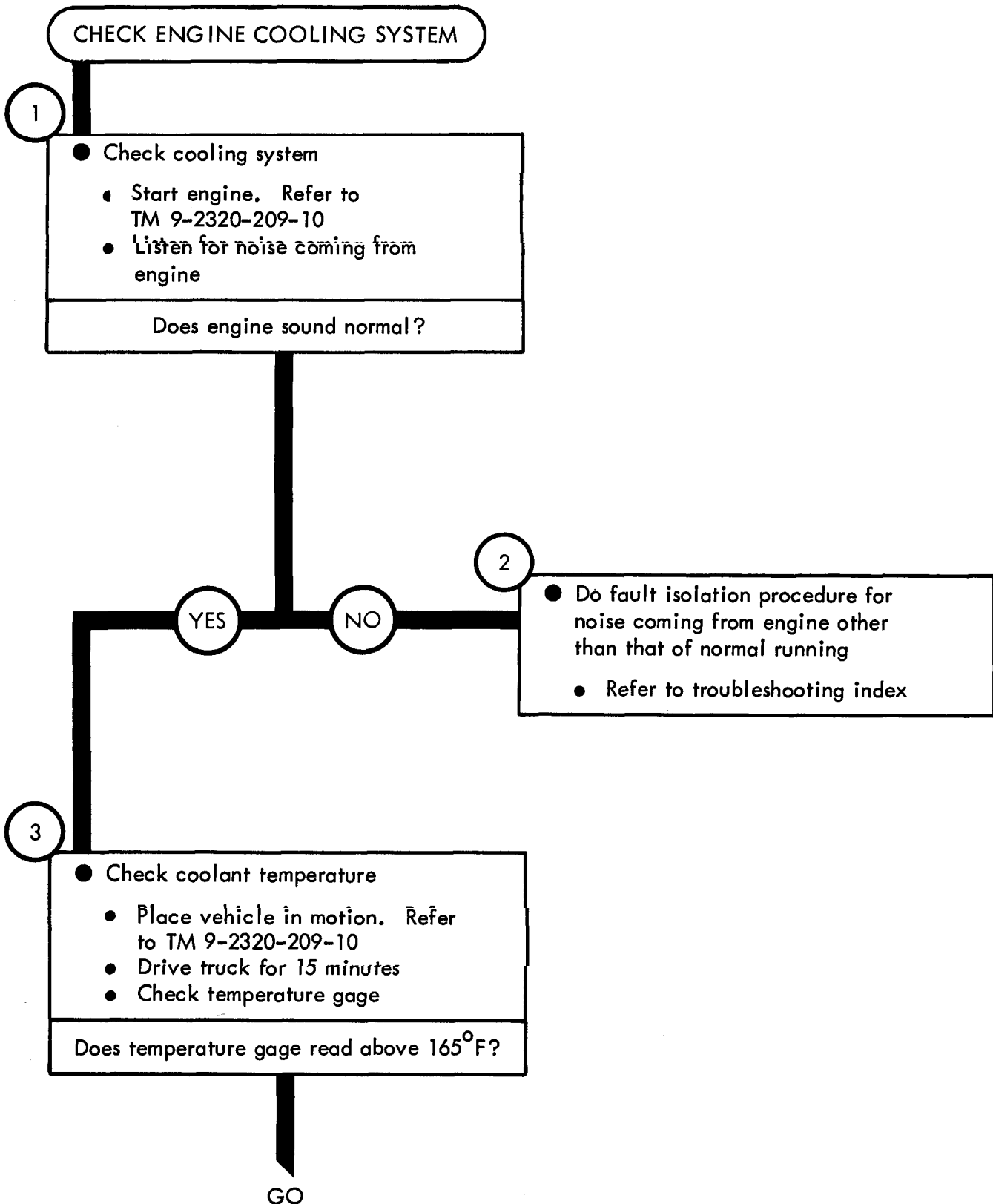

TA 114207

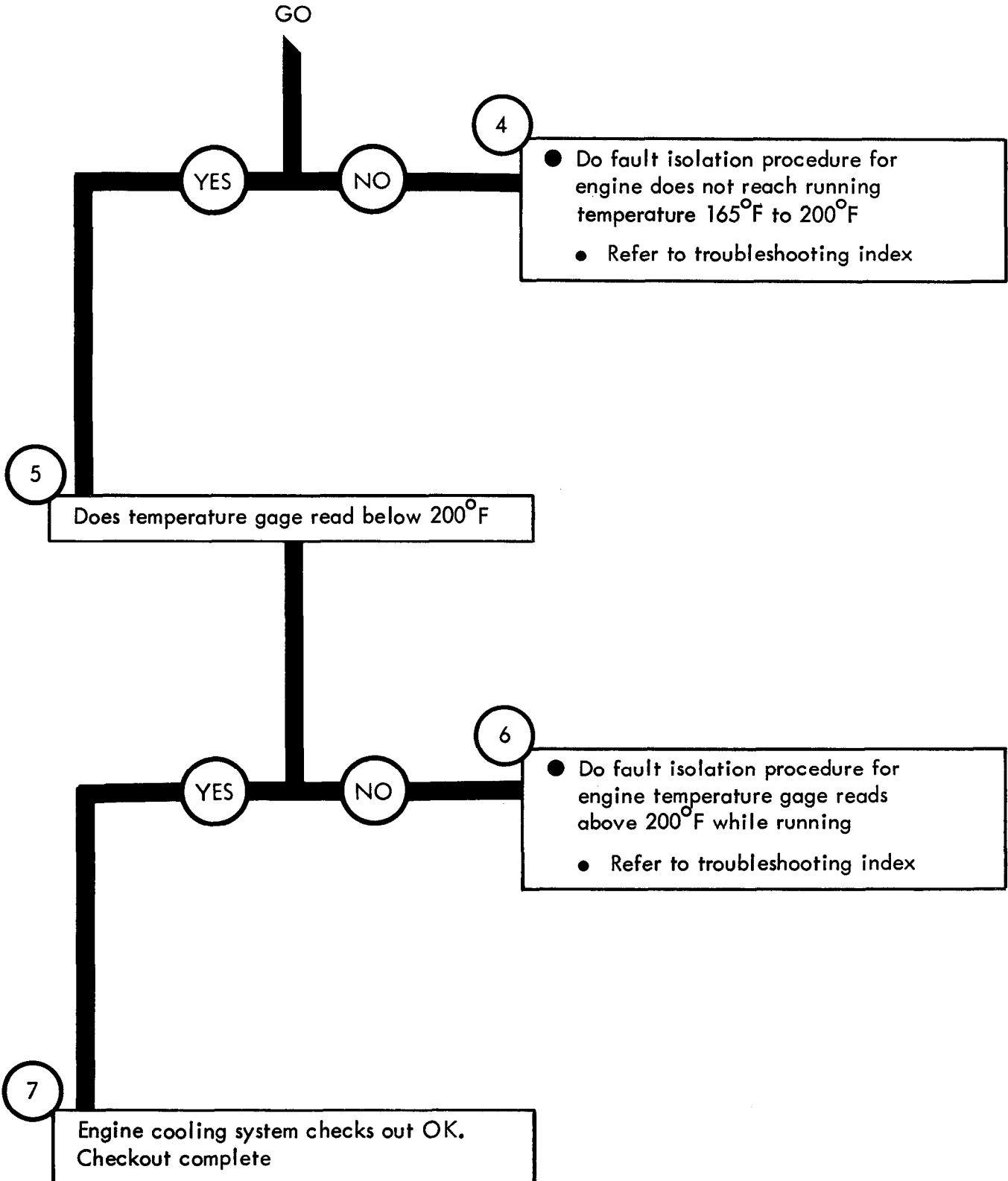

CHAPTER 25

ELECTRICAL SYSTEM TROUBLESHOOTING

25-1. EQUIPMENT ITEMS COVERED. This chapter gives equipment troubleshooting procedures for the electrical system, for which there are authorized corrective maintenance tasks at the organizational maintenance level.

25-2. EQUIPMENT ITEMS NOT COVERED. All equipment items for which corrective maintenance is authorized at the organizational maintenance level are covered in this chapter.

ELECTRICAL SYSTEM TROUBLESHOOTING

Symptom

1 STARTER MOTOR WILL NOT CRANK ENGINE

NOTE

Two soldiers are needed for some starter system checks, and are noted as Soldier A and Soldier B

When measuring voltage +24 volts DC means a range of +23 to +26 volts DC

1

- Park truck
- Refer to TM 9-2320-209-10

GO

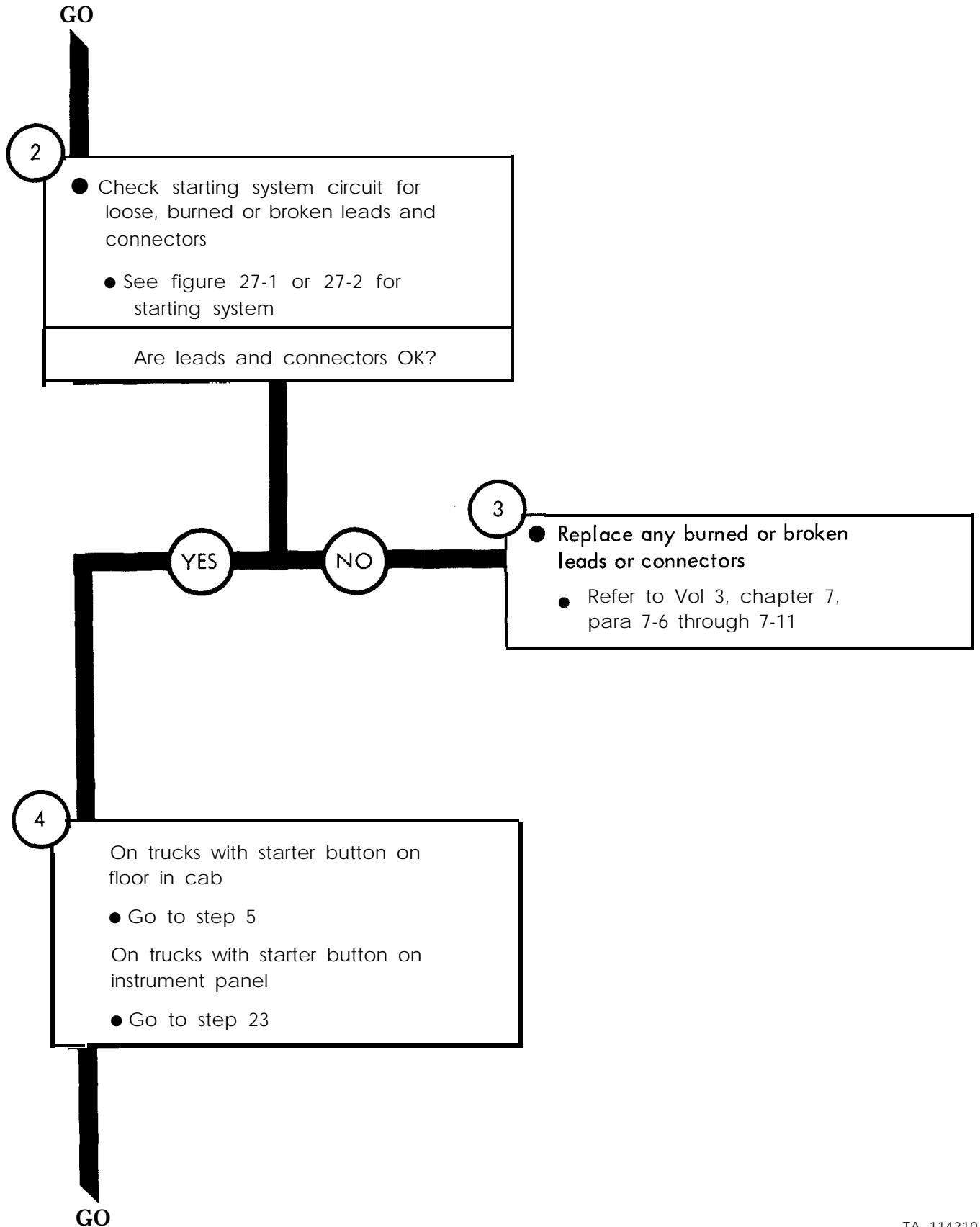

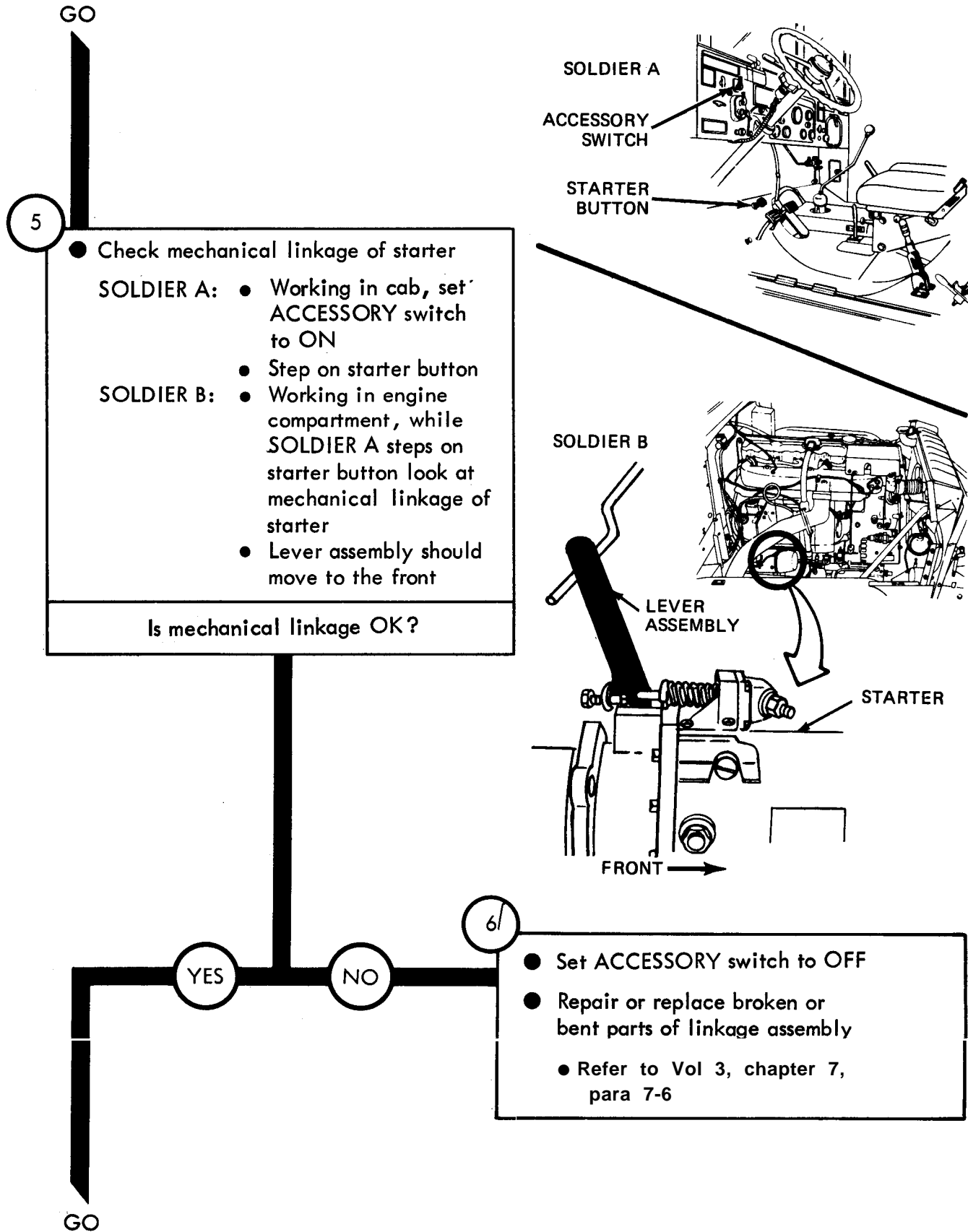

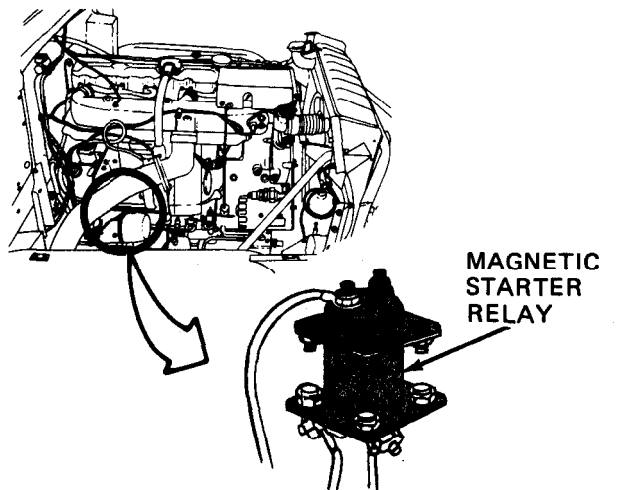
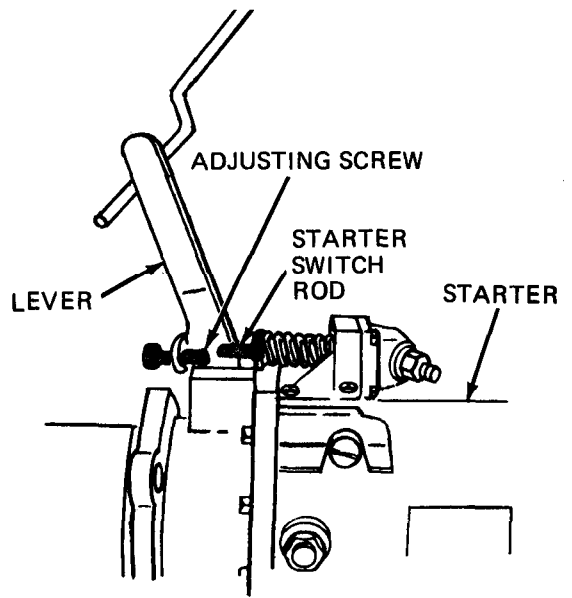
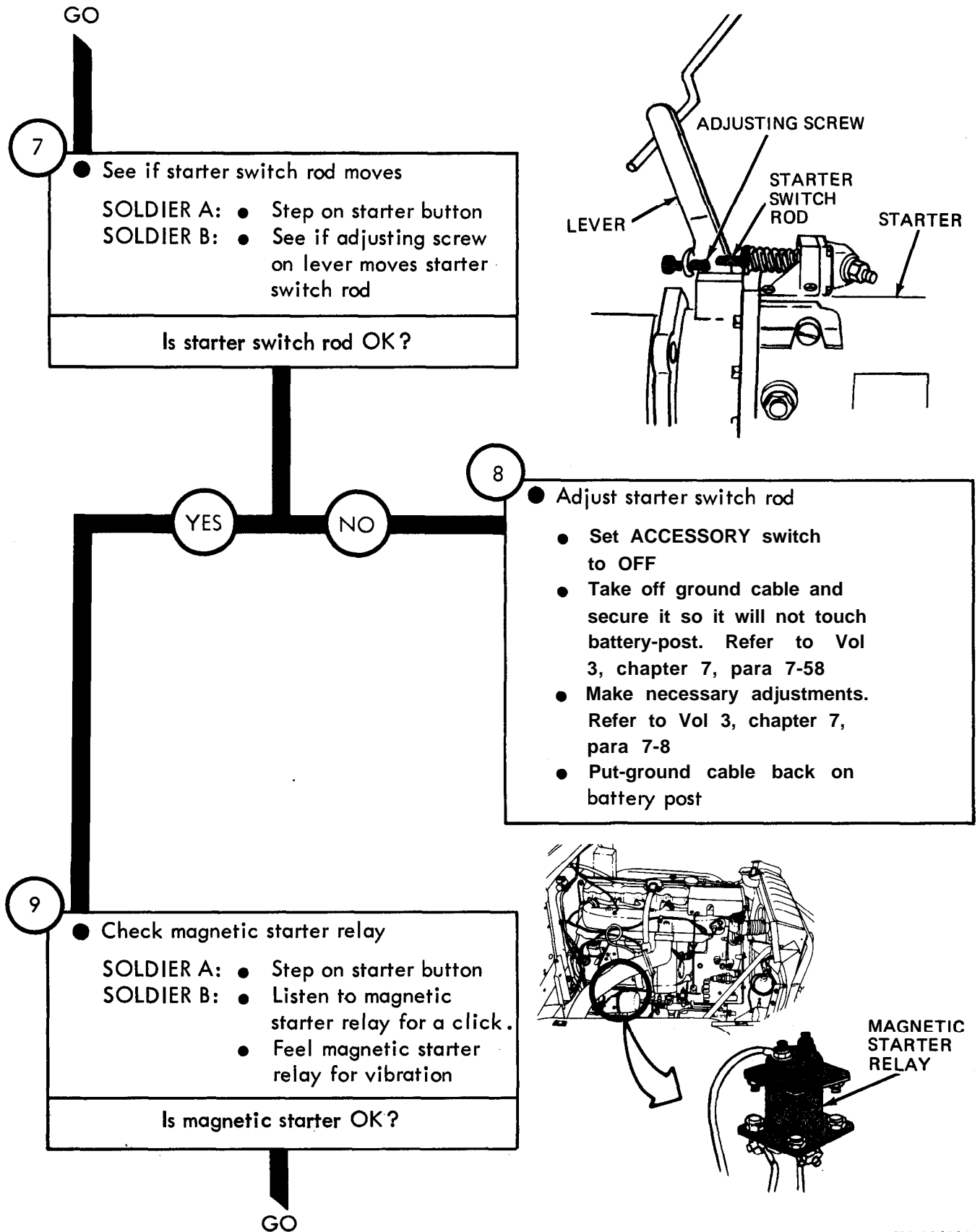
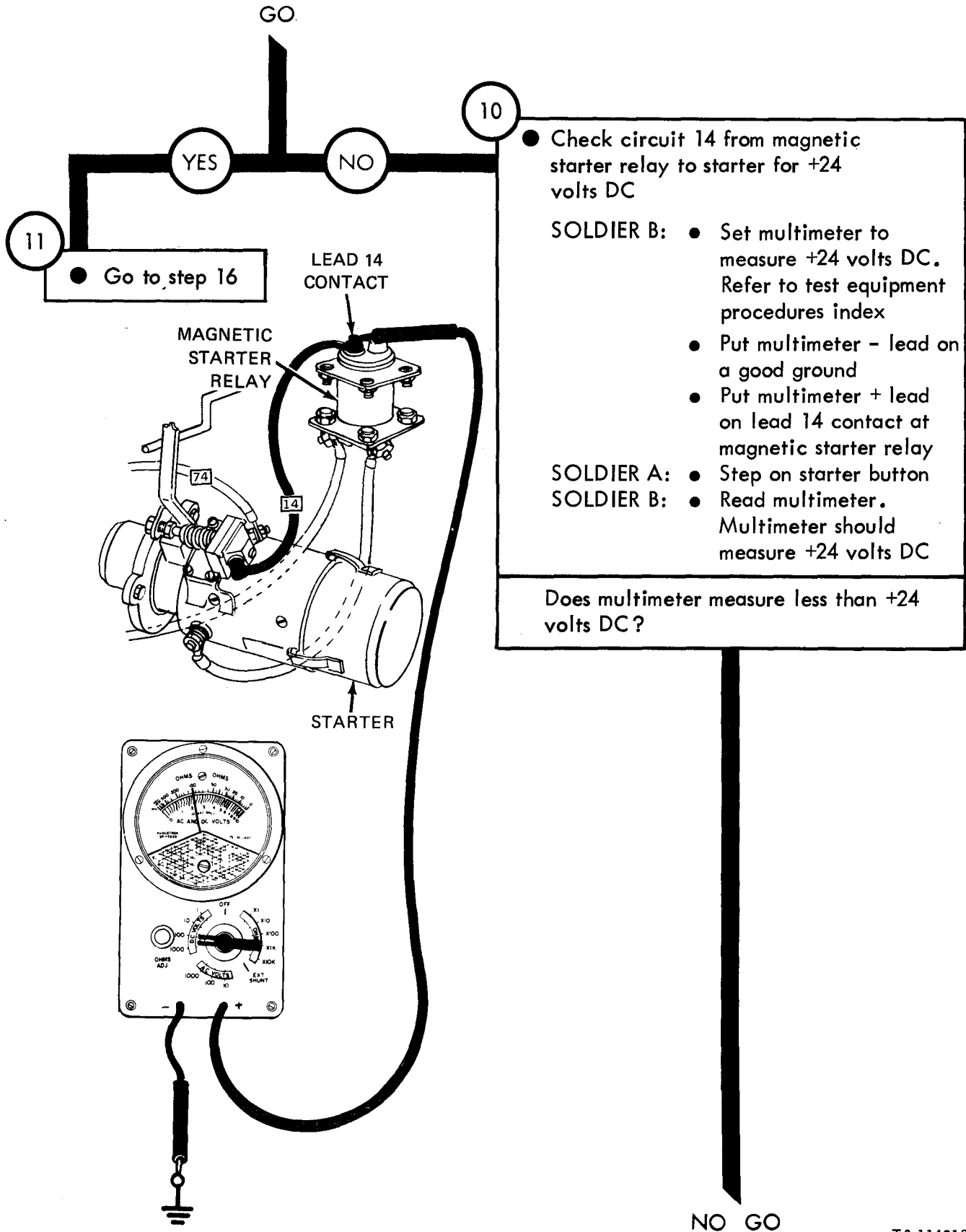

Figure 25-1 (Sheet 4 of 25)



TA 114213

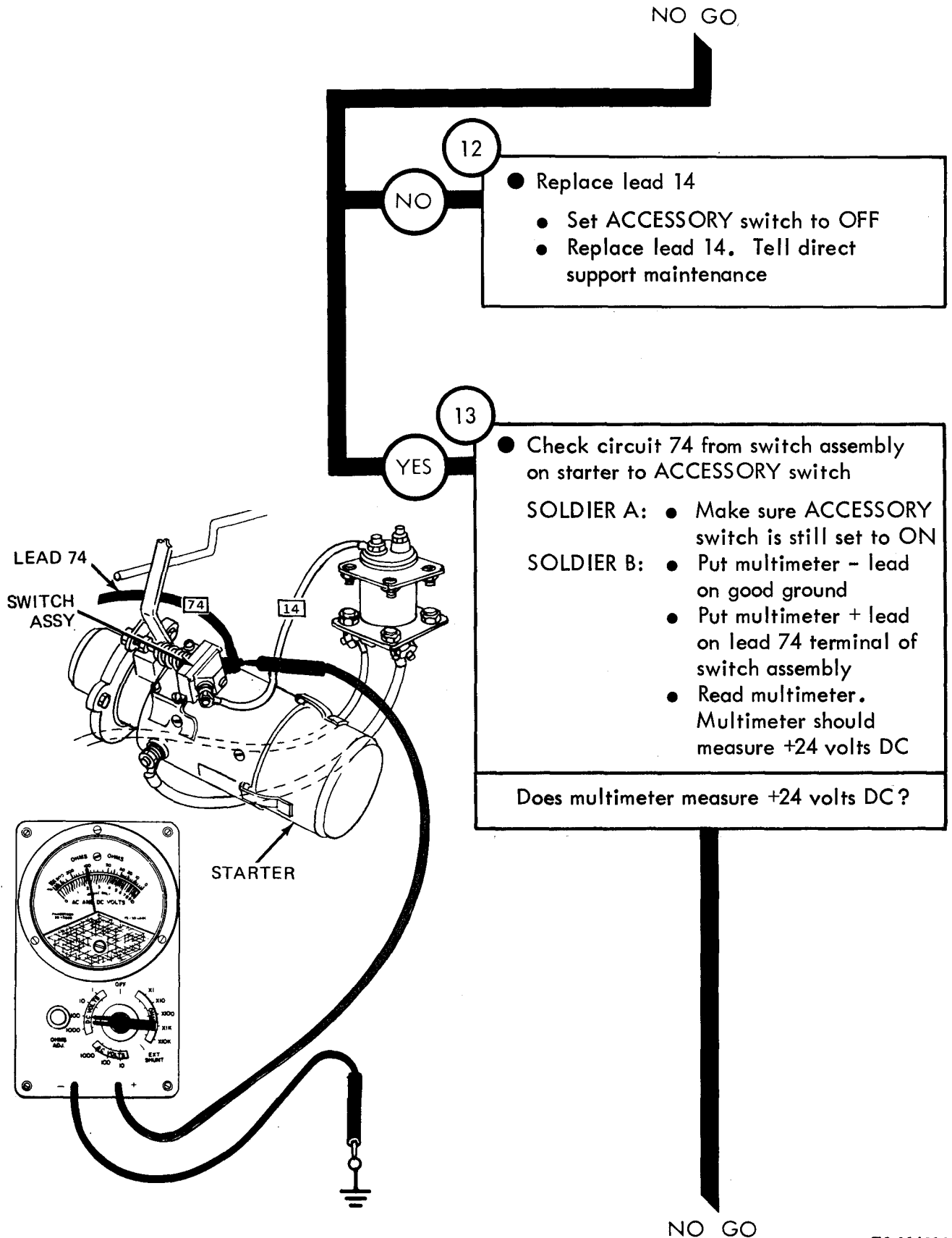
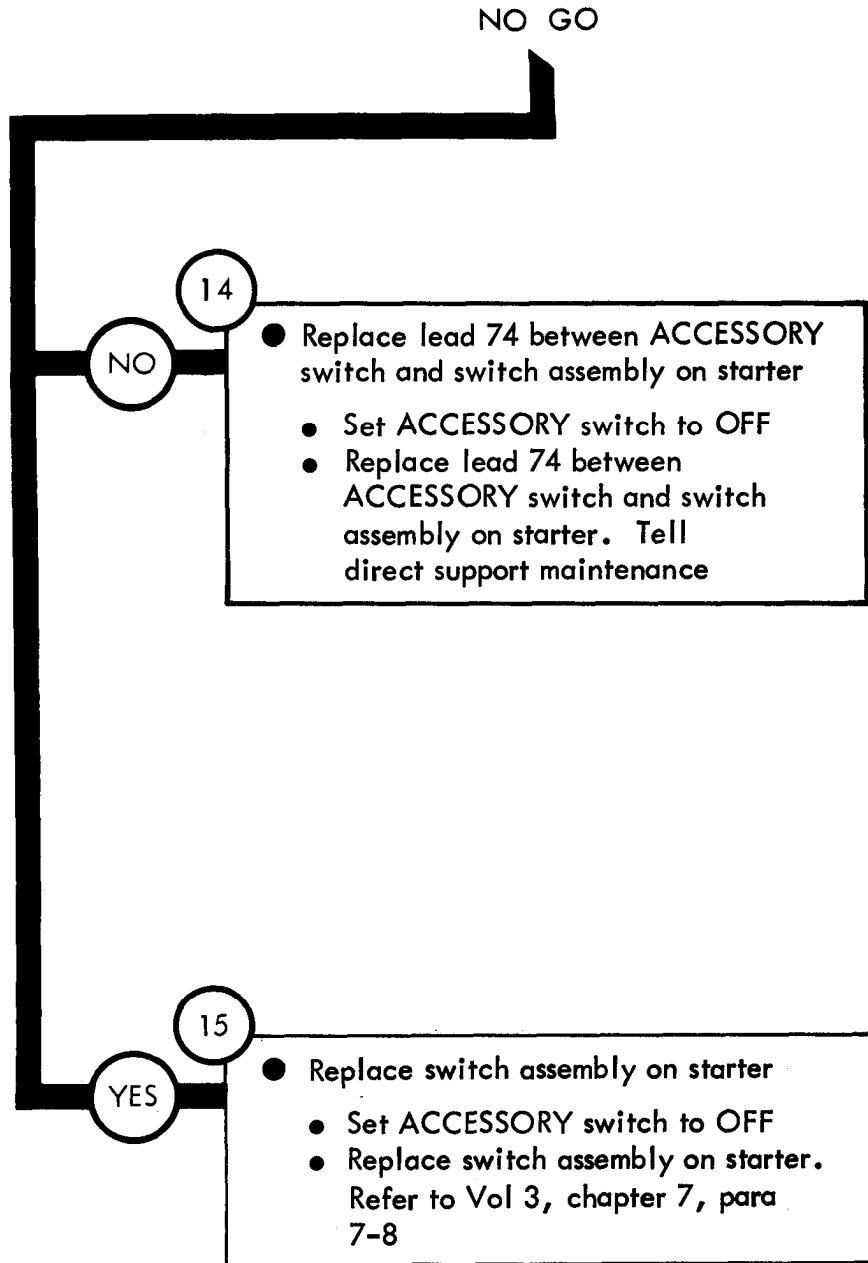

Figure 25-1 (Sheet 6 of 25)



From step 11

16

- Check for +24 volts DC (from batteries) through magnetic starter relay

SOLDIER B:

- Set multimeter to measure +24 volts DC. Refer to test equipment procedures index
- Put multimeter - lead on a good ground
- Put multimeter + lead on lead 6 terminal of magnetic starter relay

SOLDIER A:

- Step on starter button

SOLDIER B:

- Read multimeter. Multimeter should measure +24 volts DC

Does multimeter measure +24 volts DC?

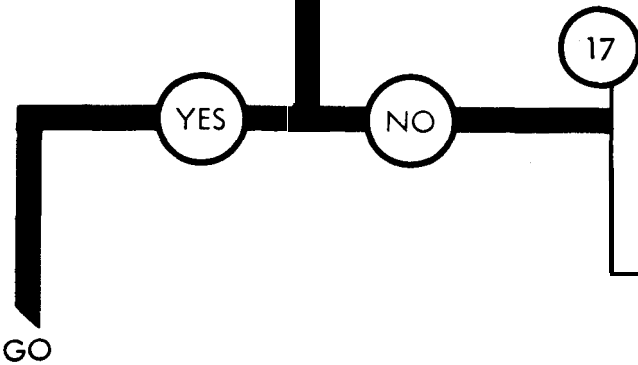
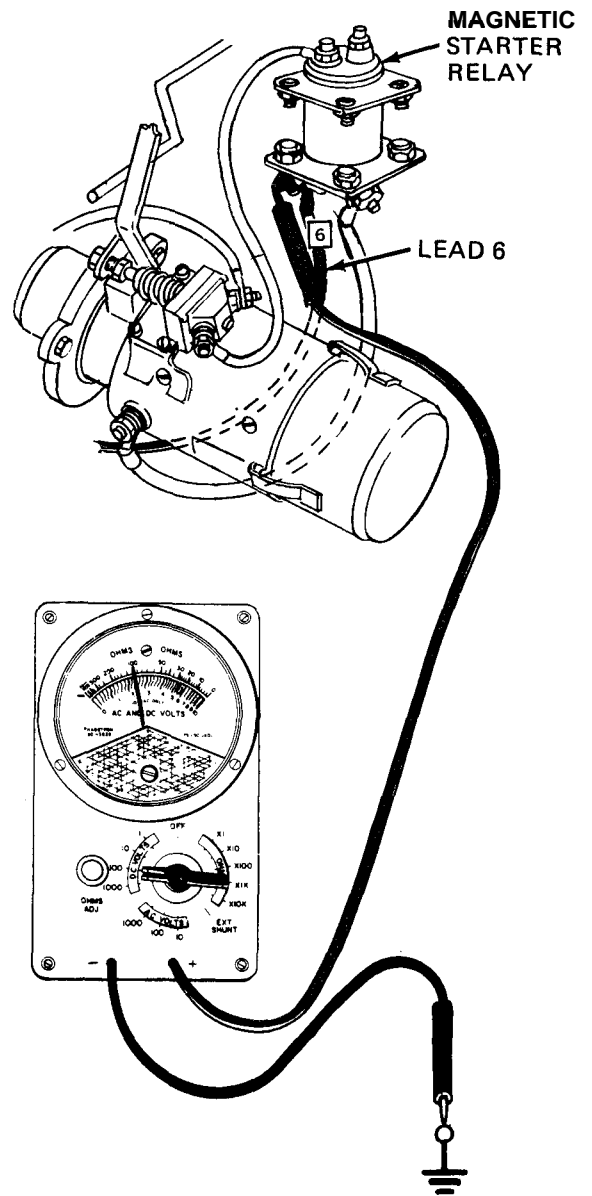

17

- Replace lead 6
- Set ACCESSORY switch to OFF
- Replace lead 6. Tell direct support maintenance

Figure 25-1 (Sheet 8 of 25)

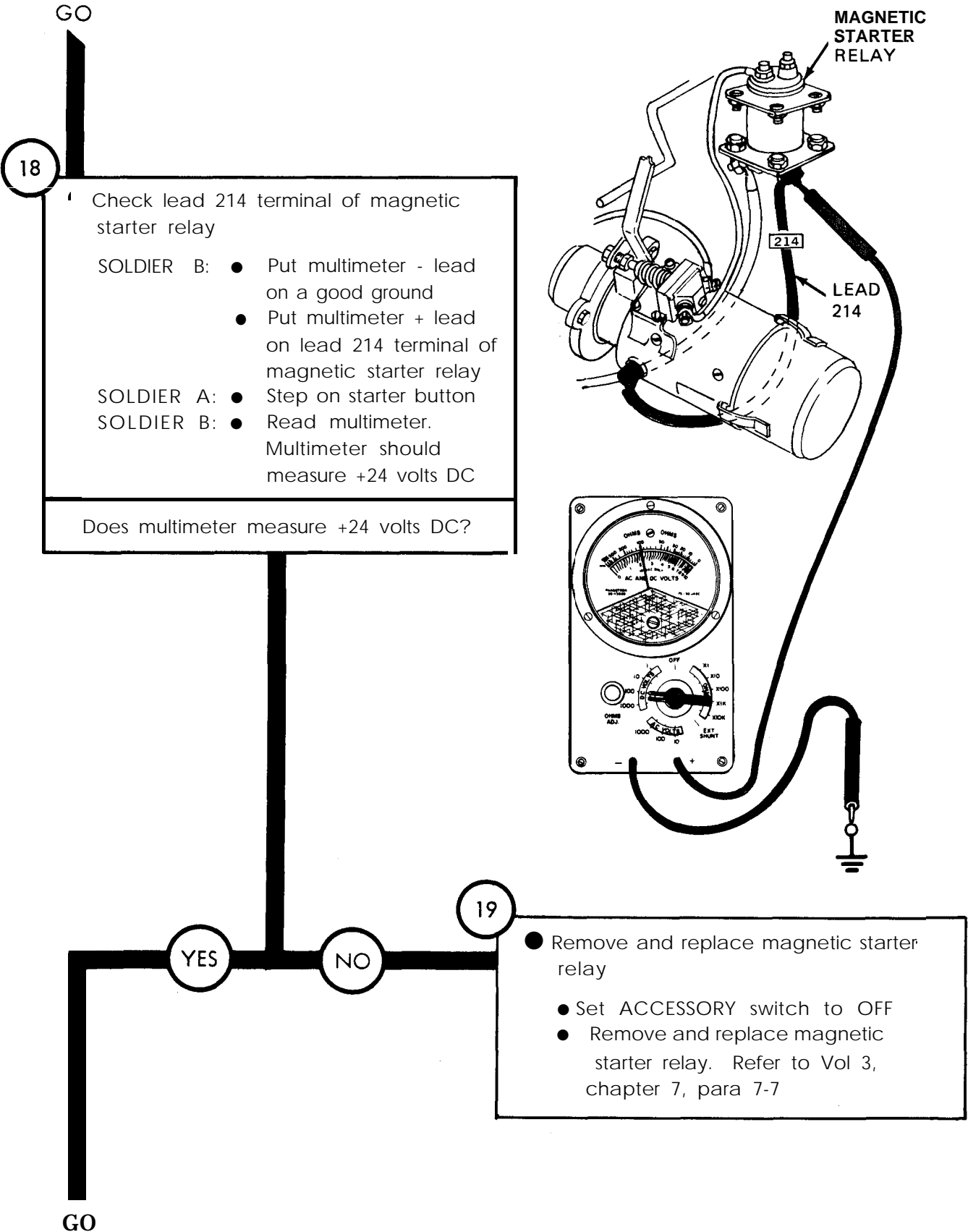

Figure 25-1 (Sheet 9 of 25)

GO

20

- Check lead 214 starter terminal for +24 volts DC

SOLDIER B: ● Put multimeter - lead on a good ground

- Put multimeter + lead on lead 214 terminal of starter

SOLDIER A: ● Step on starter button

SOLDIER B: ● Read multimeter. Multimeter should measure +24 volts DC

Does multimeter measure +24 volts DC?

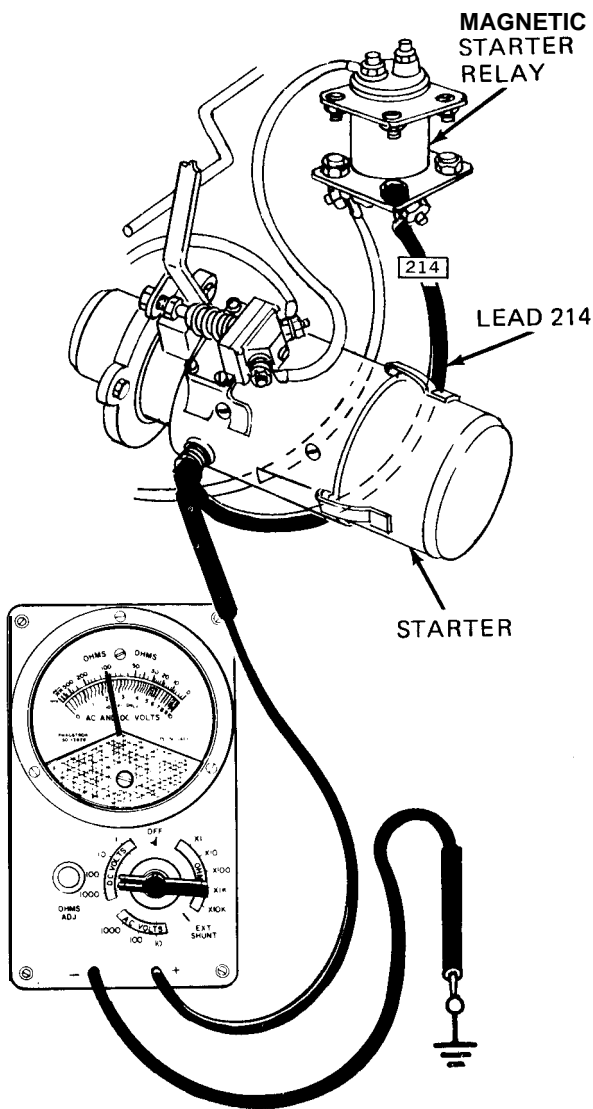

YES

NO

21

- Replace lead 214
- Set ACCESSORY switch to OFF
- Replace lead 214. Tell direct support maintenance

22

- Replace starter
- Set ACCESSORY switch to OFF
- Replace starter. Refer to Vol 3, chapter 7, para 7-10 or 7-11

From step 4

23

- Check magnetic starter relay

SOLDIER A: ● Press starter button

SOLDIER B: ● Listen to magnetic starter relay for click

- Feel magnetic starter relay for vibration

Is magnetic relay OK?

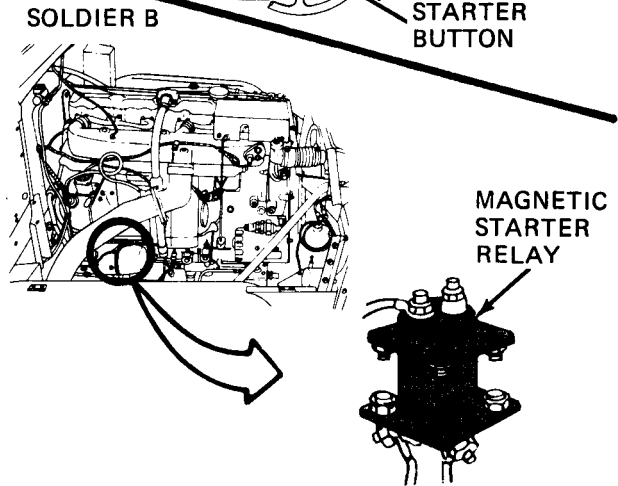
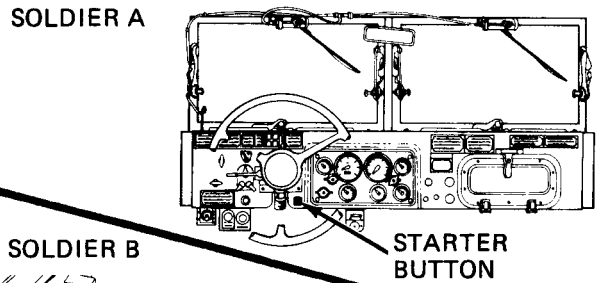

24

- Check for +24 volts DC from batteries through starter switch to magnetic starter relay

SOLDIER A: ● Set ACCESSORY switch to ON

SOLDIER B: ● Set multimeter to read +24 volts DC. Refer to test equipment procedures index

- Put multimeter - lead on a good ground and + lead on lead 74 (74B) terminal of magnetic starter relay

SOLDIER A: ● Press starter switch

SOLDIER B: ● Read multimeter. Multimeter should measure +24 volts DC

Does multimeter measure +24 volts DC?

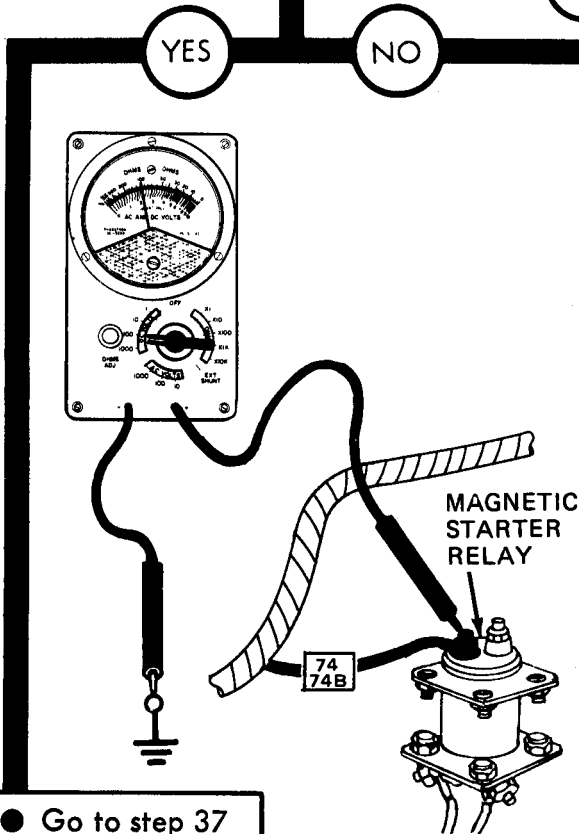

25

- Go to step 37

NO GO

TA 114219

Figure 25-1 (Sheet 11 of 25)

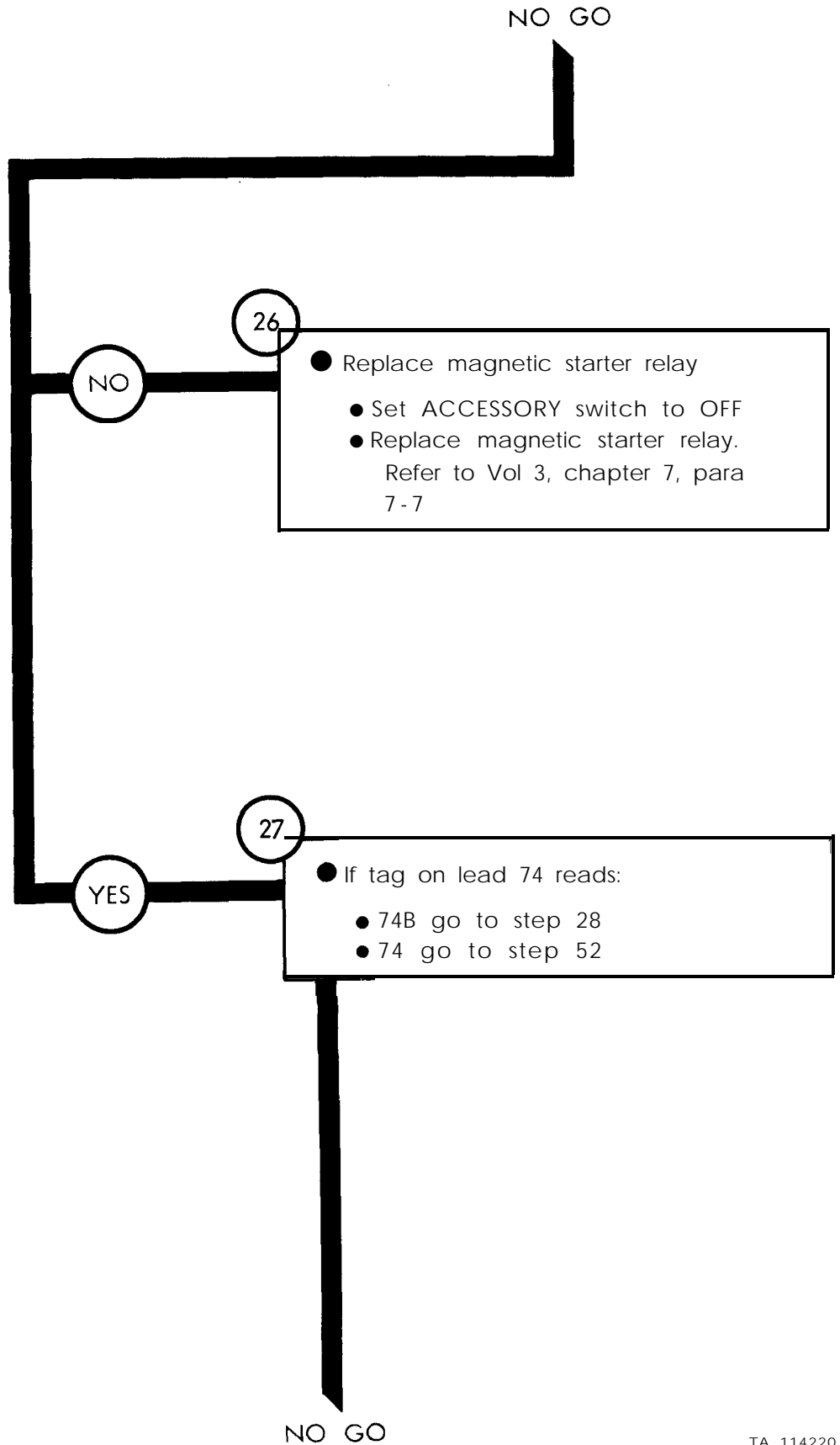

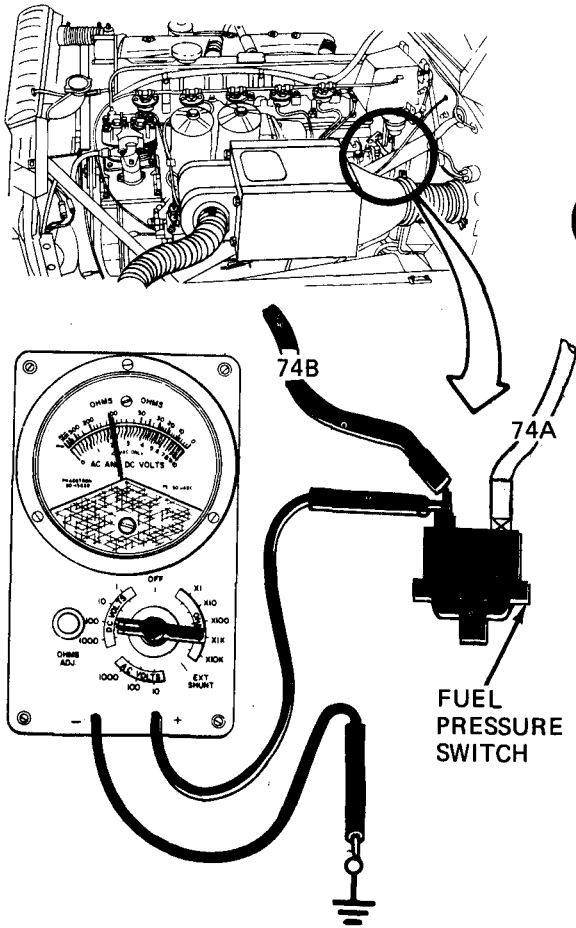

NO GO

28

- Check lead 74B for +24 volts DC
- SOLDIER B:
- Take off lead 74B from fuel pressure switch
 - Put multimeter - lead on a good ground
 - Put multimeter + lead on lead 74B terminal of fuel pressure switch
- SOLDIER A:
- Press starter switch
- SOLDIER B:
- Read multimeter. Multimeter should measure +24 volts DC

Does multimeter measure less than +24 volts DC?

29

- Replace front harness
- Set ACCESSORY switch to OFF
- Replace front harness. Tell direct support maintenance

NO

NO GO

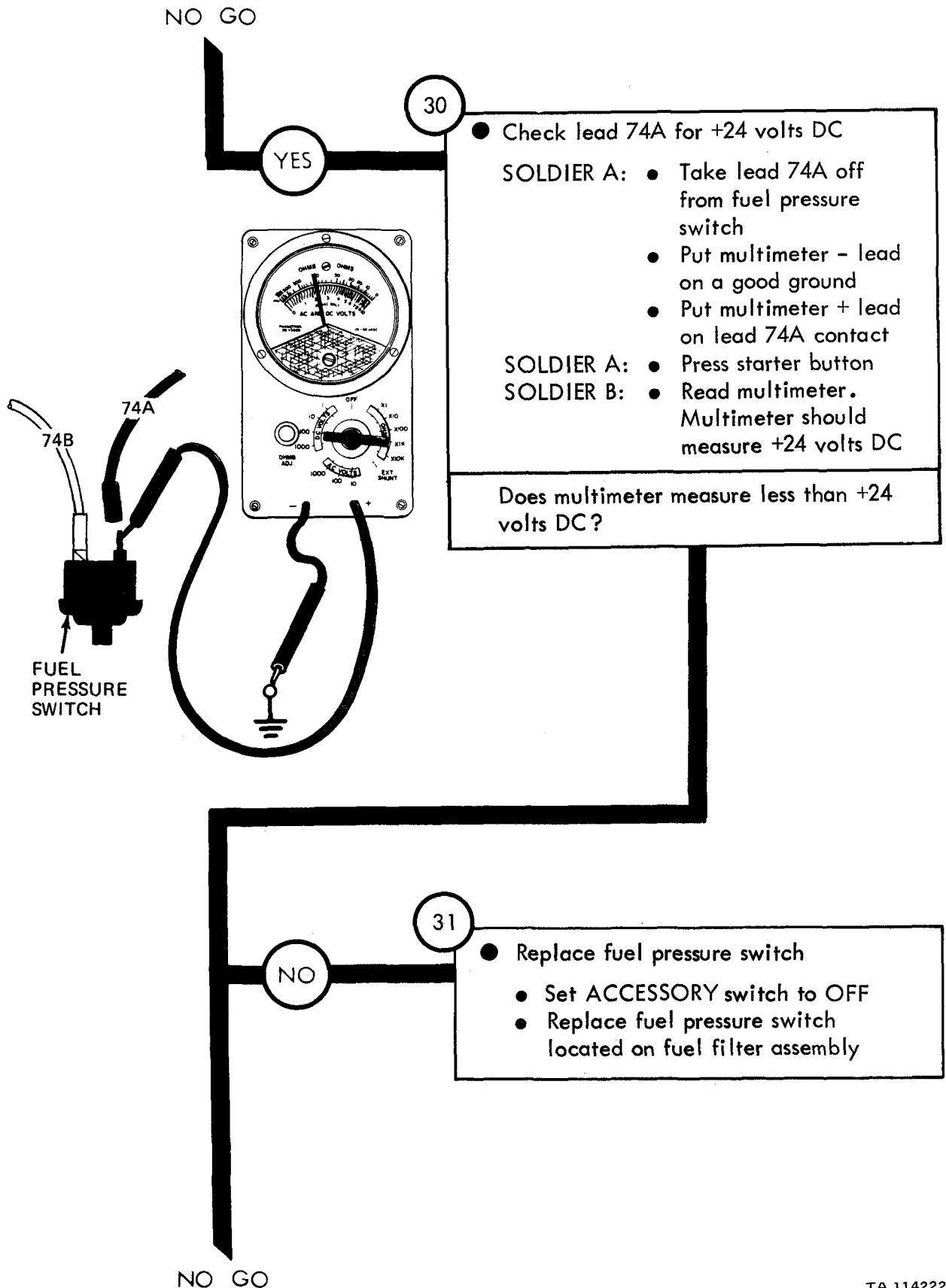
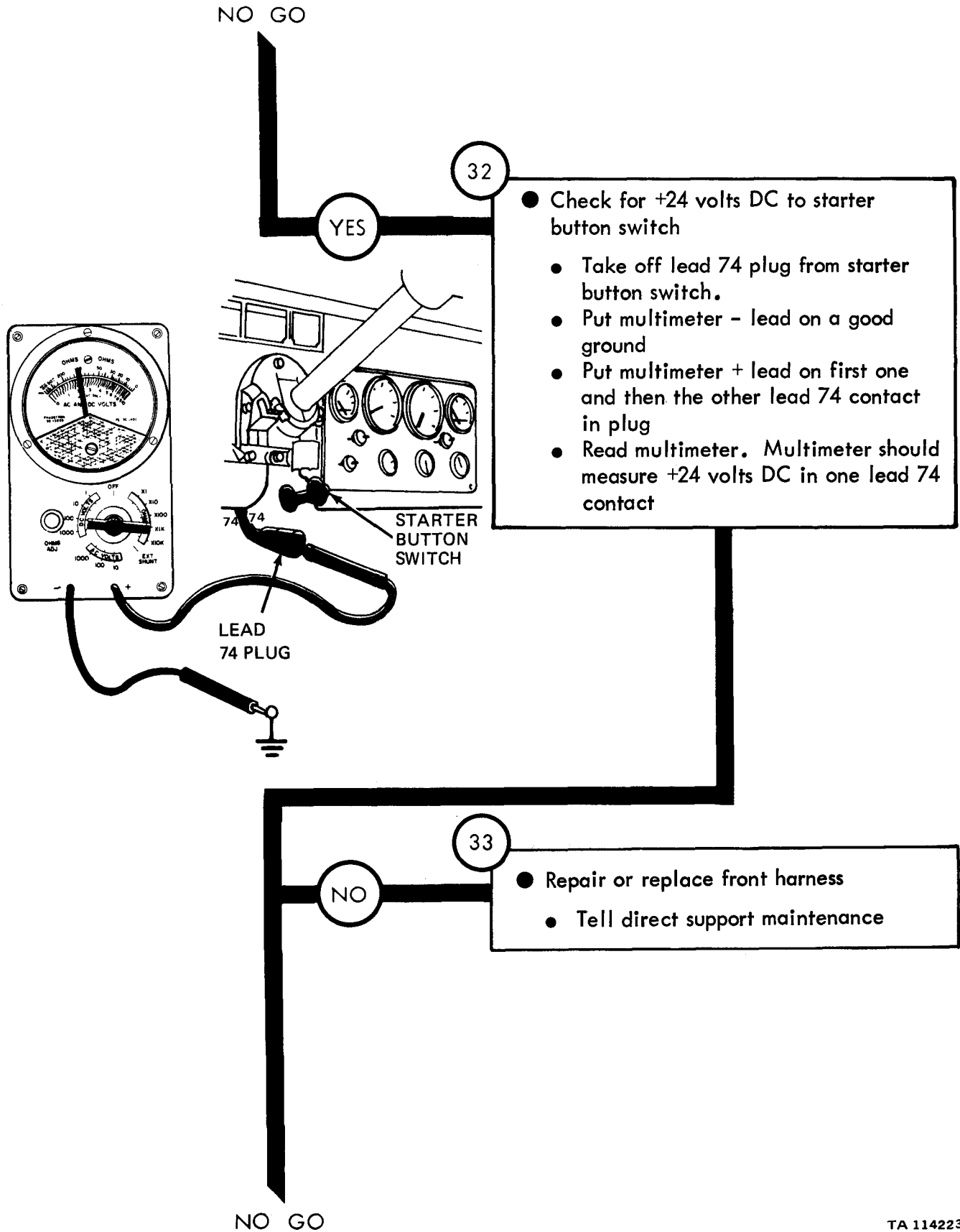
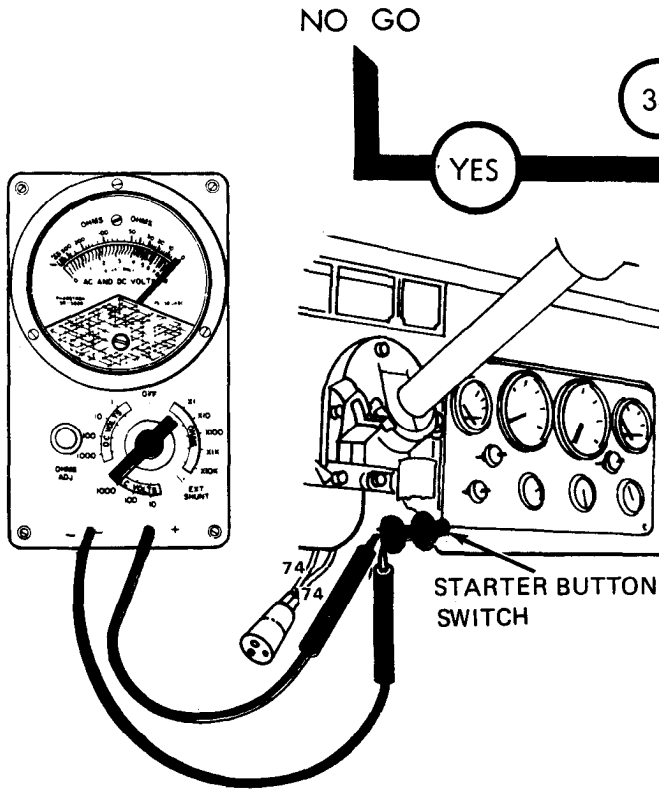

Figure 25-1 (Sheet 14 of 25)



TA 114223



- 34**
- Check starter button switch for continuity
 - Set multimeter to check continuity. Refer to test equipment procedures index
 - Fold back rubber boot on starter button switch to reach terminals
 - Put multimeter - lead on one starter button switch terminal
 - Put multimeter + lead on other starter button switch terminal
 - Push starter button. Read multimeter. Multimeter should measure 0 to 5 ohms

Does multimeter measure more than 5 ohms?

- NO**
- 35**
- Repair or replace lead 74 harness between starter button switch and magnetic starter relay
 - Set ACCESSORY switch to OFF
 - Repair or replace lead 74 harness.
 - Tell direct support maintenance

- YES**
- 36**
- Replace starter button switch
 - Set ACCESSORY switch to OFF
 - Replace starter button switch. Refer to Vol 3, chapter 7, para 7-9

From step 25

37

● Check starter solenoid

SOLDIER A: ● Press starter button
 SOLDIER B: ● While SOLDIER A presses starter button put your hand on starter solenoid and see if it jolts (vibrates)

Does solenoid jolt (vibrate)?

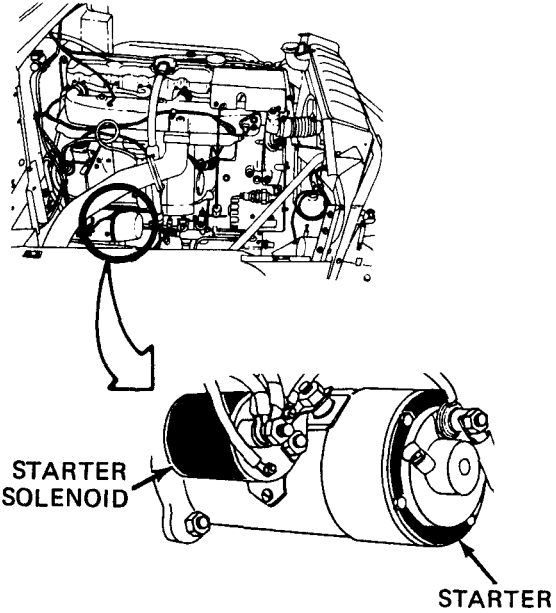

YES

NO

39

● Go to step 52

38

● Check for +24 volts to starter solenoid

SOLDIER B: ● Set multimeter to measure +24 volts DC. Refer to test equipment procedures index
 ● Put multimeter - lead on a good ground
 ● Put multimeter + lead on lead 6 terminal of starter solenoid

SOLDIER A: ● Press starter button
 SOLDIER B: ● Read multimeter. Multimeter should measure +24 volts DC

Does multimeter measure +24 volts DC?

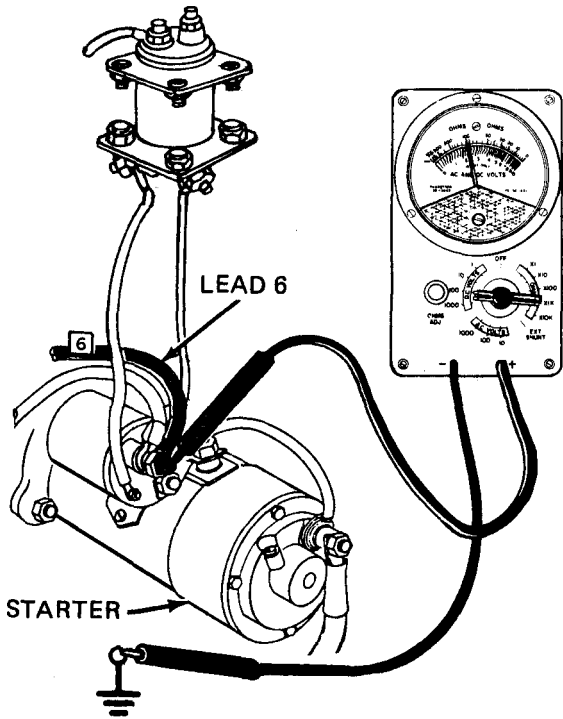

NO GO

TA 114225

Figure 25-1 (Sheet 17 of 25)

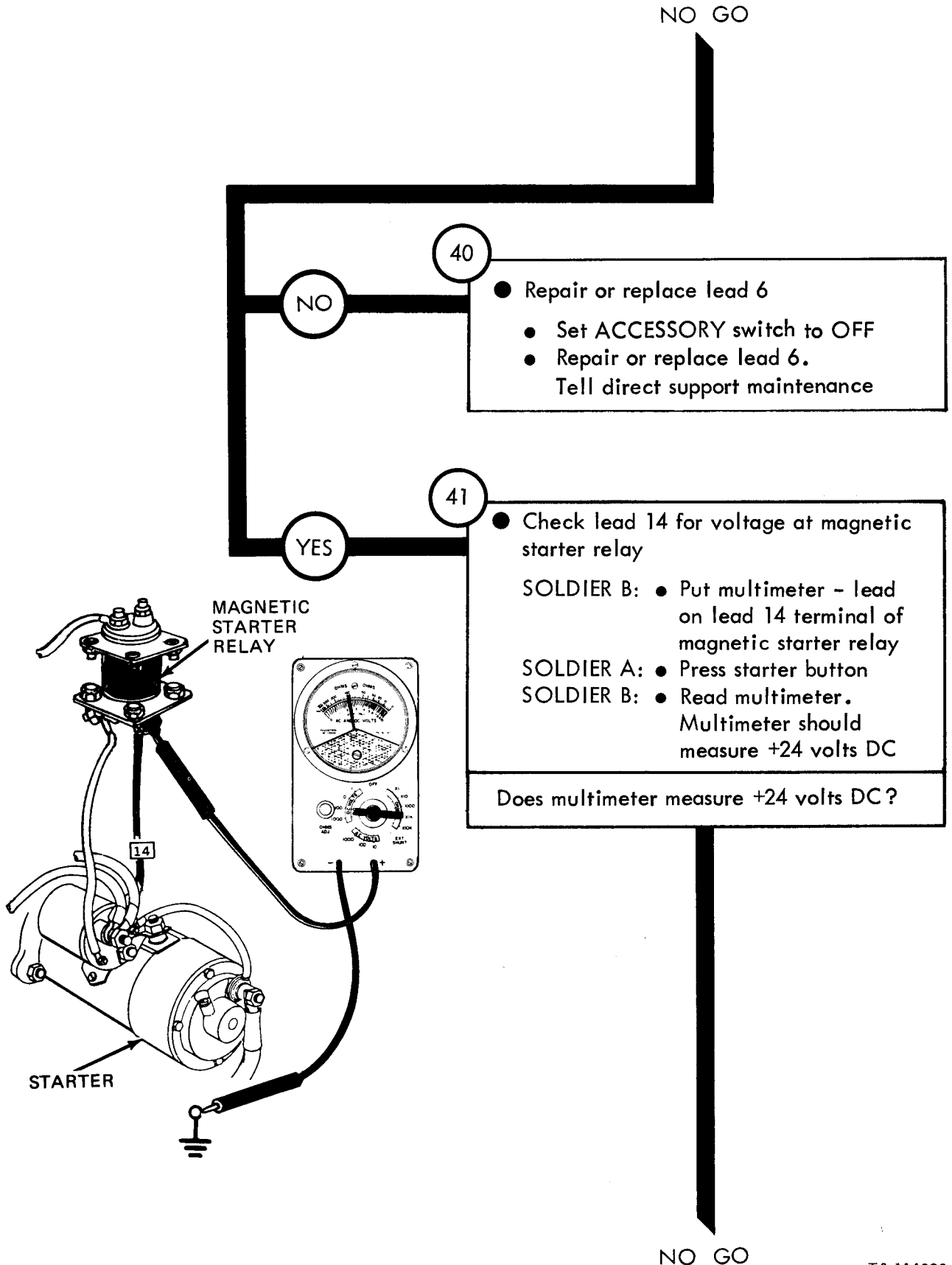
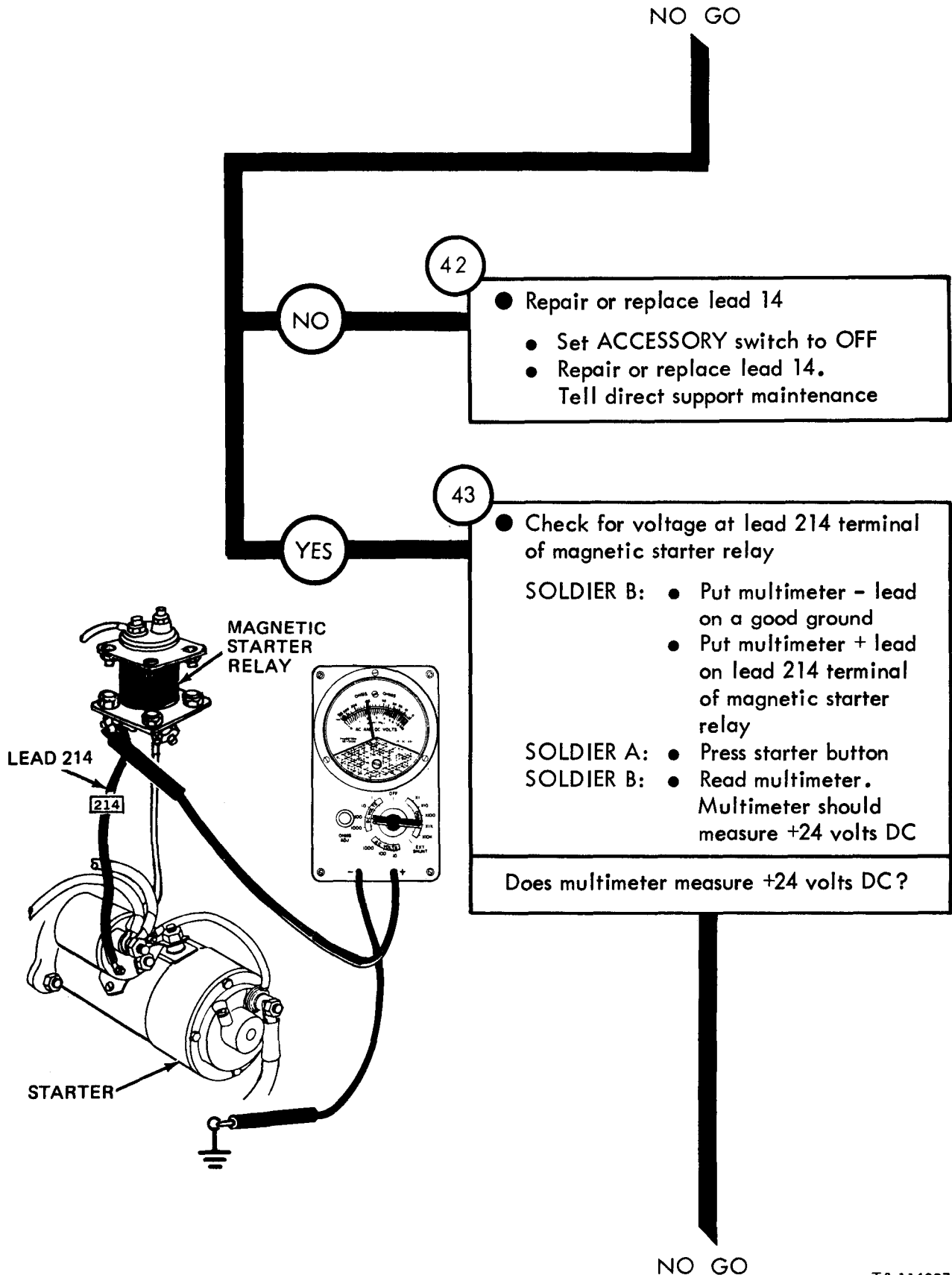

Figure 25-1 (Sheet 18 of 25)



TA 114227

Figure 25-1 (Sheet 19 of 25)

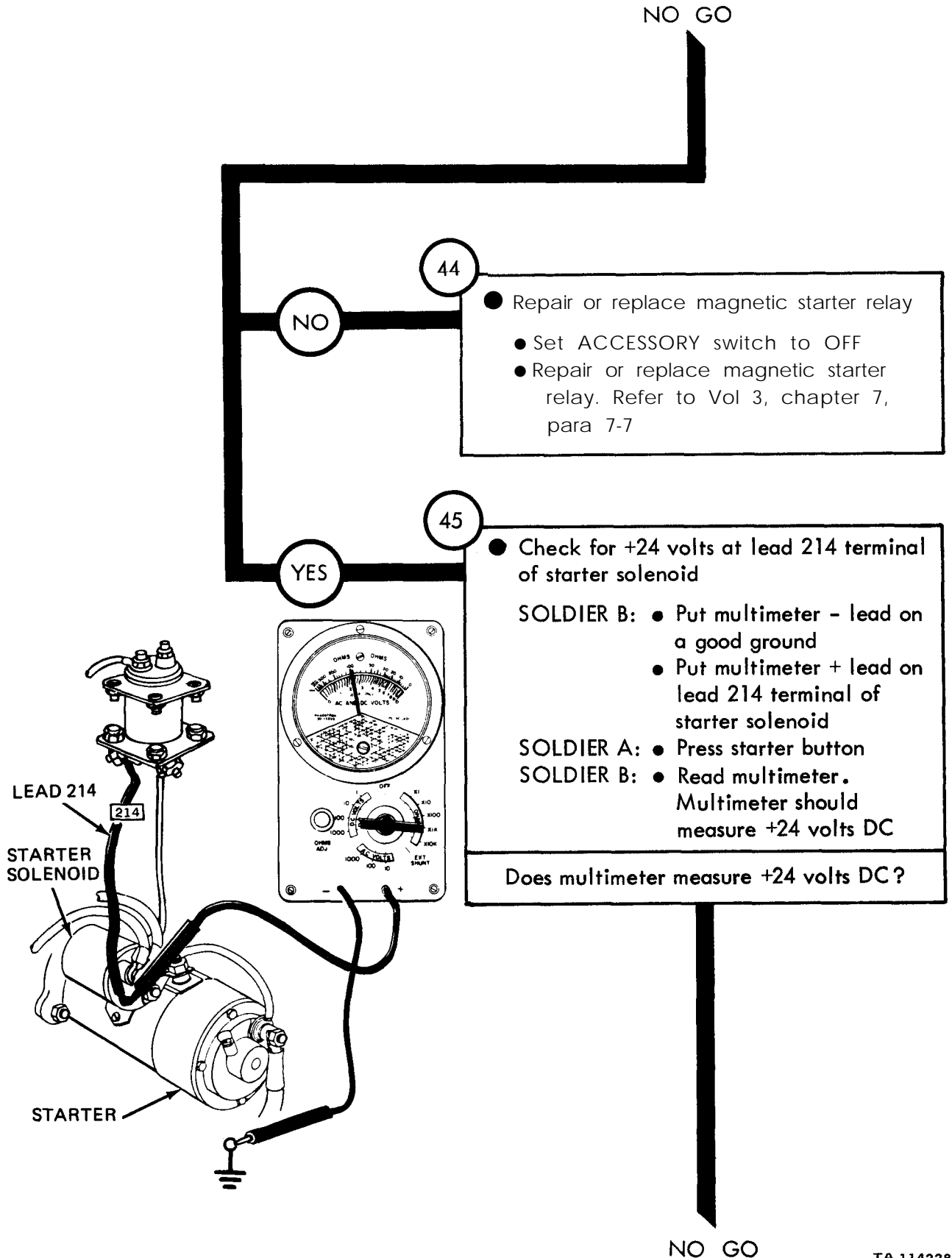
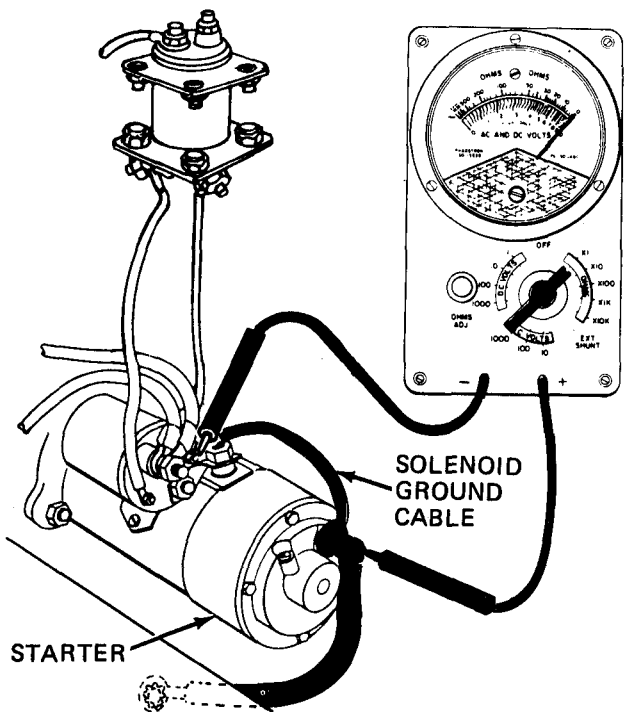
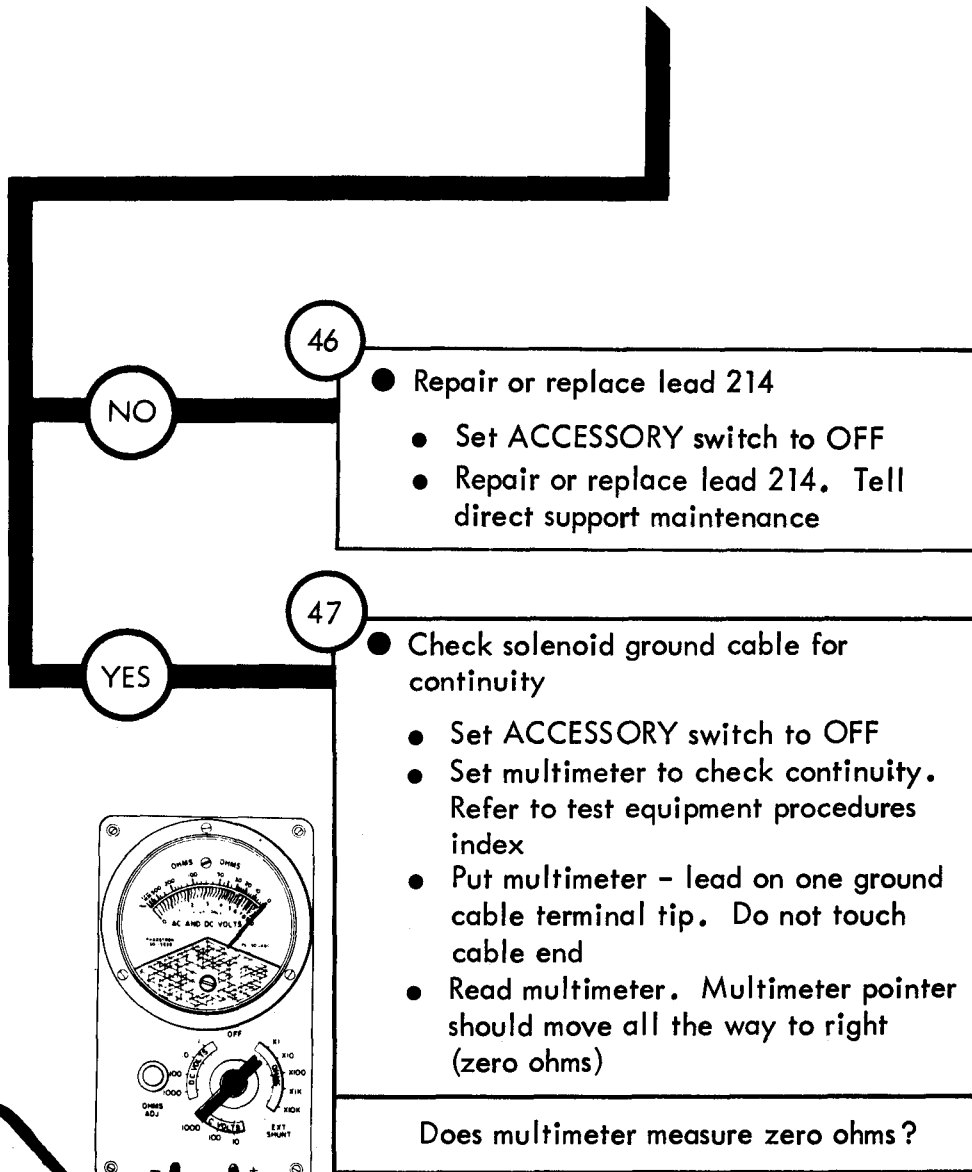

Figure 25-1 (Sheet 20 of 25)

NO GO



Does multimeter measure zero ohms?

NO GO

TA 114229

Figure 25-1 (Sheet 21 of 25)

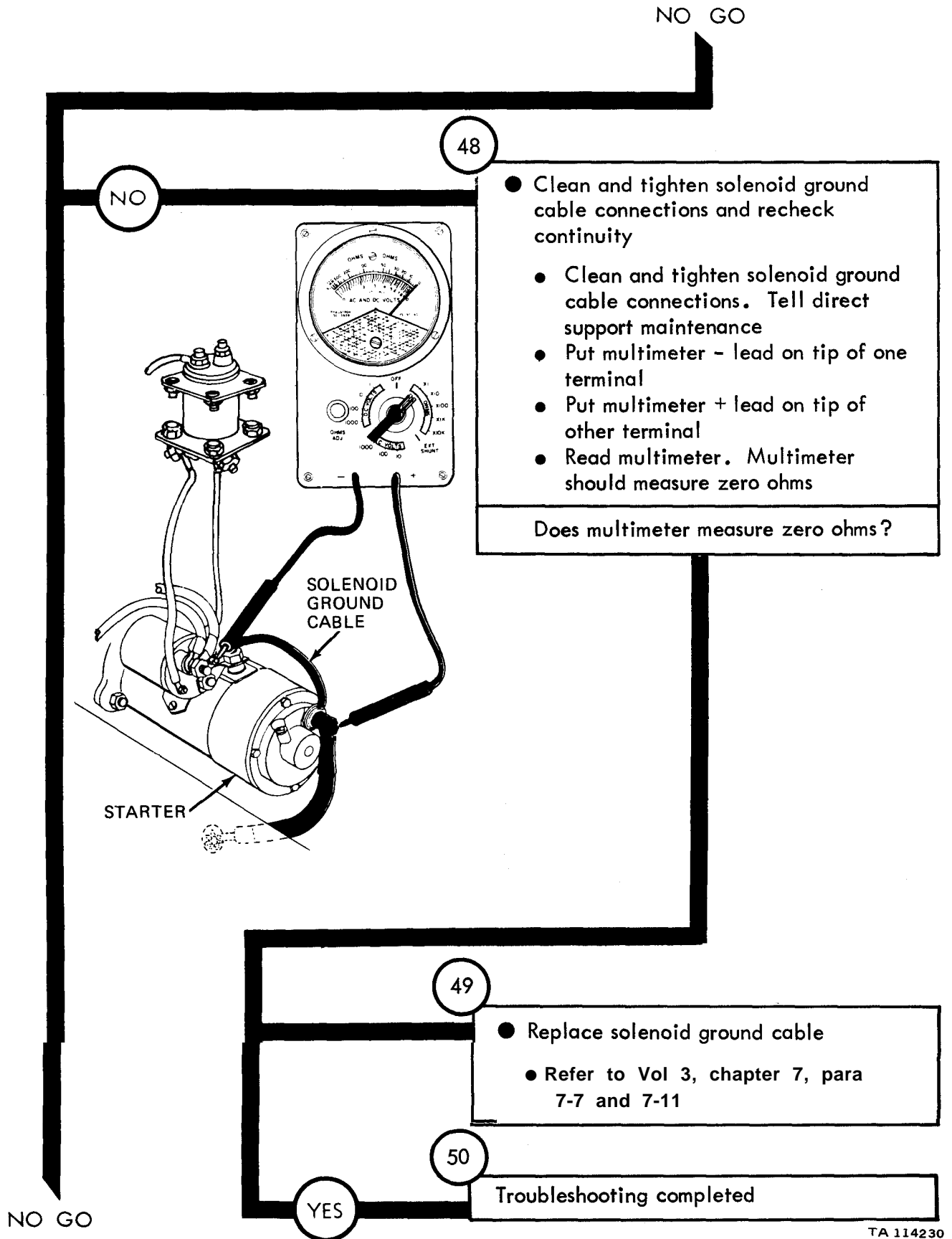

TA 114230

Figure 25-1 (Sheet 22 of 25)

NO GO

YES

51

- Replace starter motor
- Refer to Vol 3, chapter 7, para 7-10 or 7-11

From step 27

52

- Check starter motor ground cable for continuity
 - Set ACCESSORY switch to OFF
 - Set multimeter to check continuity. Refer to multimeter test procedures, test 4
 - Put multimeter - lead on bolt at ground end of cable (see illustration)
 - Put multimeter + lead on tip of starter ground cable terminal (see illustration)
 - Read multimeter. Multimeter should measure zero ohms

Does multimeter measure zero ohms?

GO

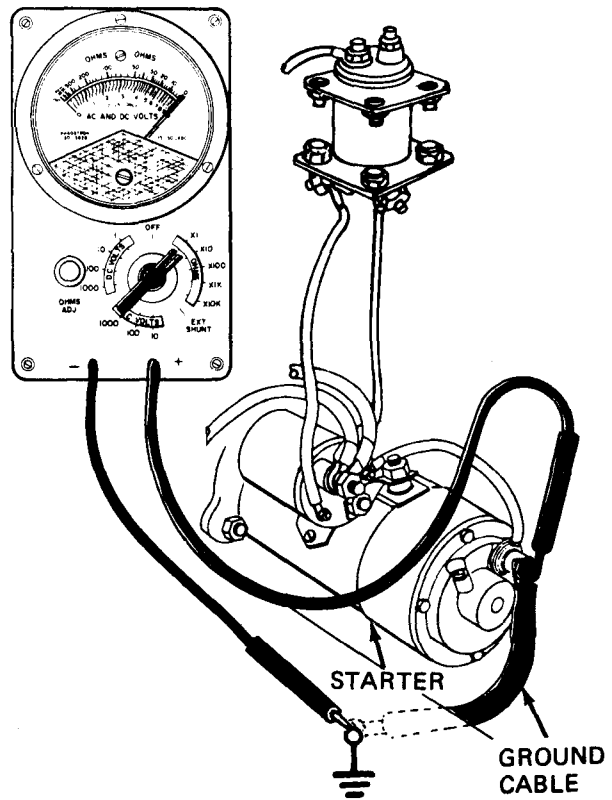

TA 114231

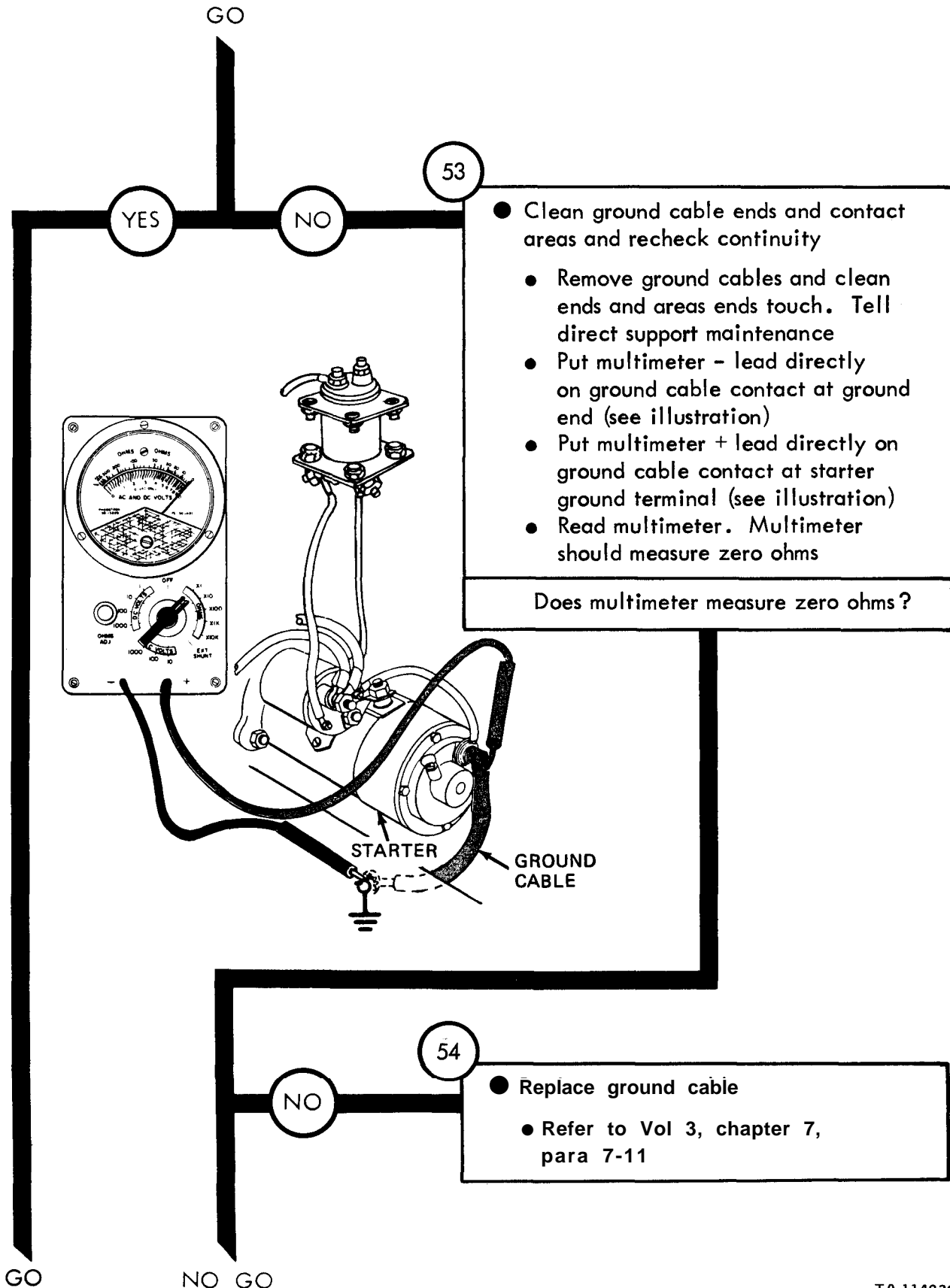

- Clean ground cable ends and contact areas and recheck continuity
- Remove ground cables and clean ends and areas ends touch. Tell direct support maintenance
- Put multimeter - lead directly on ground cable contact at ground end (see illustration)
- Put multimeter + lead directly on ground cable contact at starter ground terminal (see illustration)
- Read multimeter. Multimeter should measure zero ohms

Does multimeter measure zero ohms?

- Replace ground cable
- Refer to Vol 3, chapter 7, para 7-11

Figure 25-1 (Sheet 24 of 25)

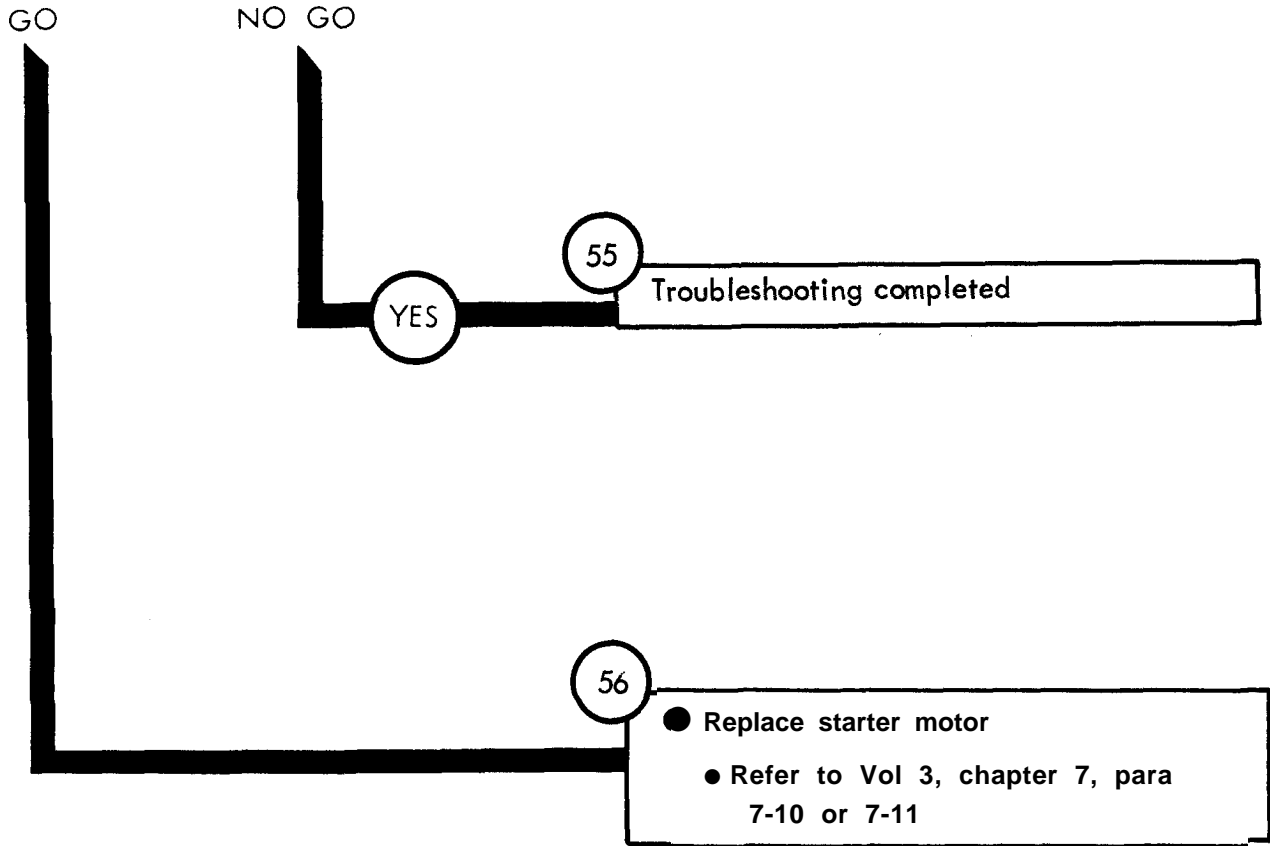

Figure 25-1 (Sheet 25 of 25)

Symptom

2

CHARGING SYSTEM (25 AMP, GENERATOR) HAS TOO HIGH OR LOW CHARGING RATE

NOTE

Make all charging system checks after run and engine compartment is hot
 When measuring voltage +28 volts means a range of +27 to +28.5 volts

1

- Park truck
 - Refer to TM 9-2320-209-10

2

- Test generator armature
 - Set ACCESSORY switch to OFF
 - Take off generator to regulator cable from generator gooseneck. Refer to Vol 3, chapter 7, para 7-59
 - Put generator adapter in generator gooseneck connector
 - If you don't have a generator adapter do multimeter measurements at generator gooseneck

GO

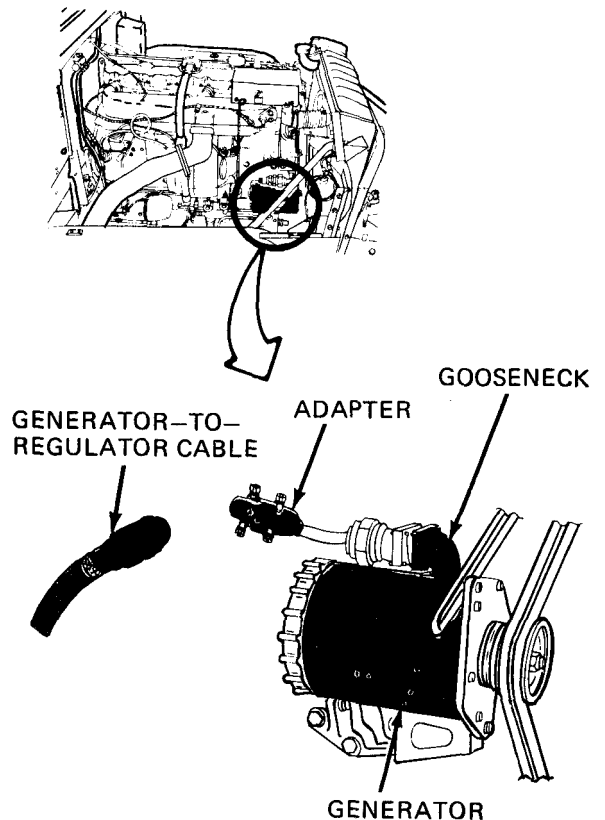

TA 114234

Figure 25-2 (Sheet 1 of 13)

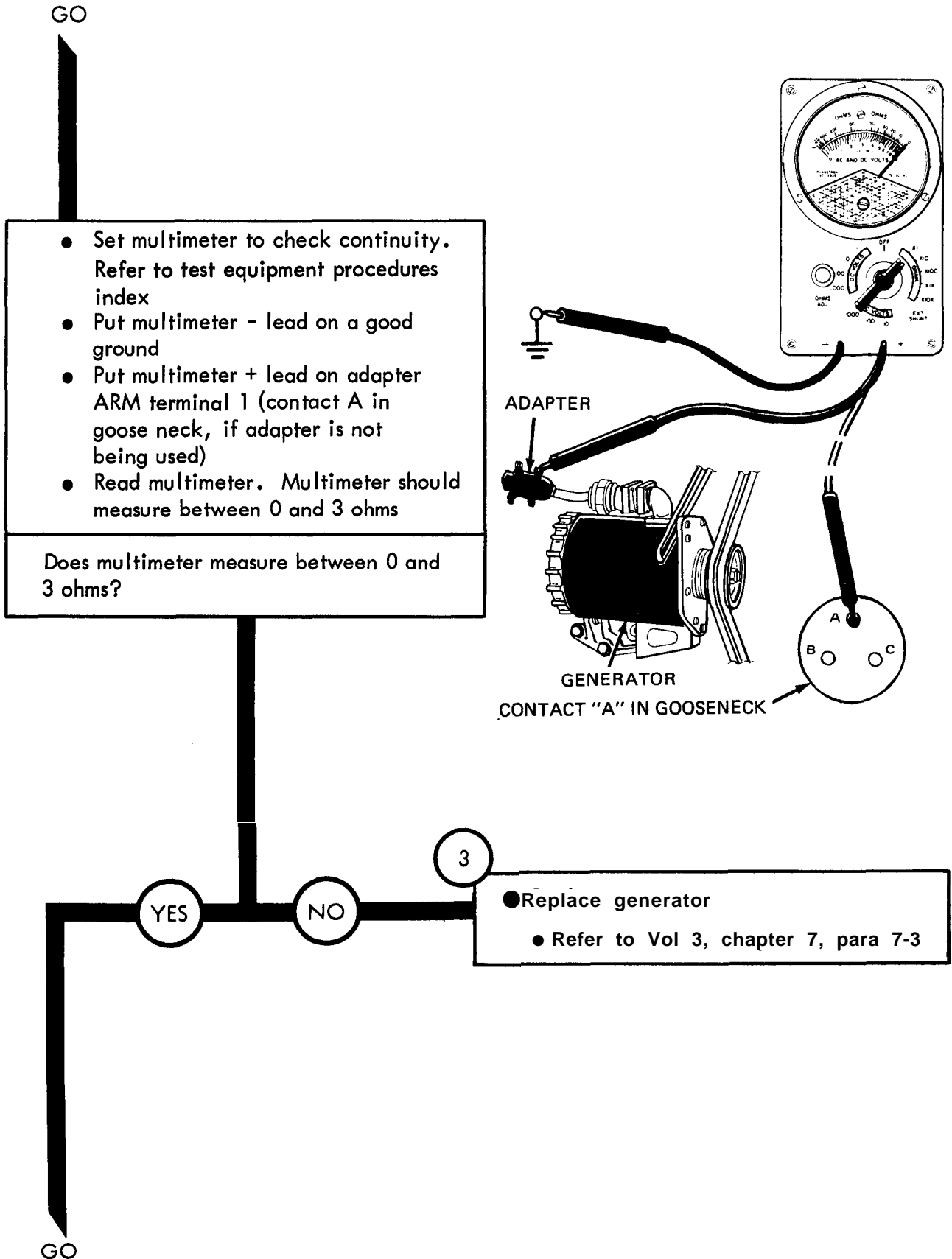

Figure 25-2 (Sheet 2 of 13)

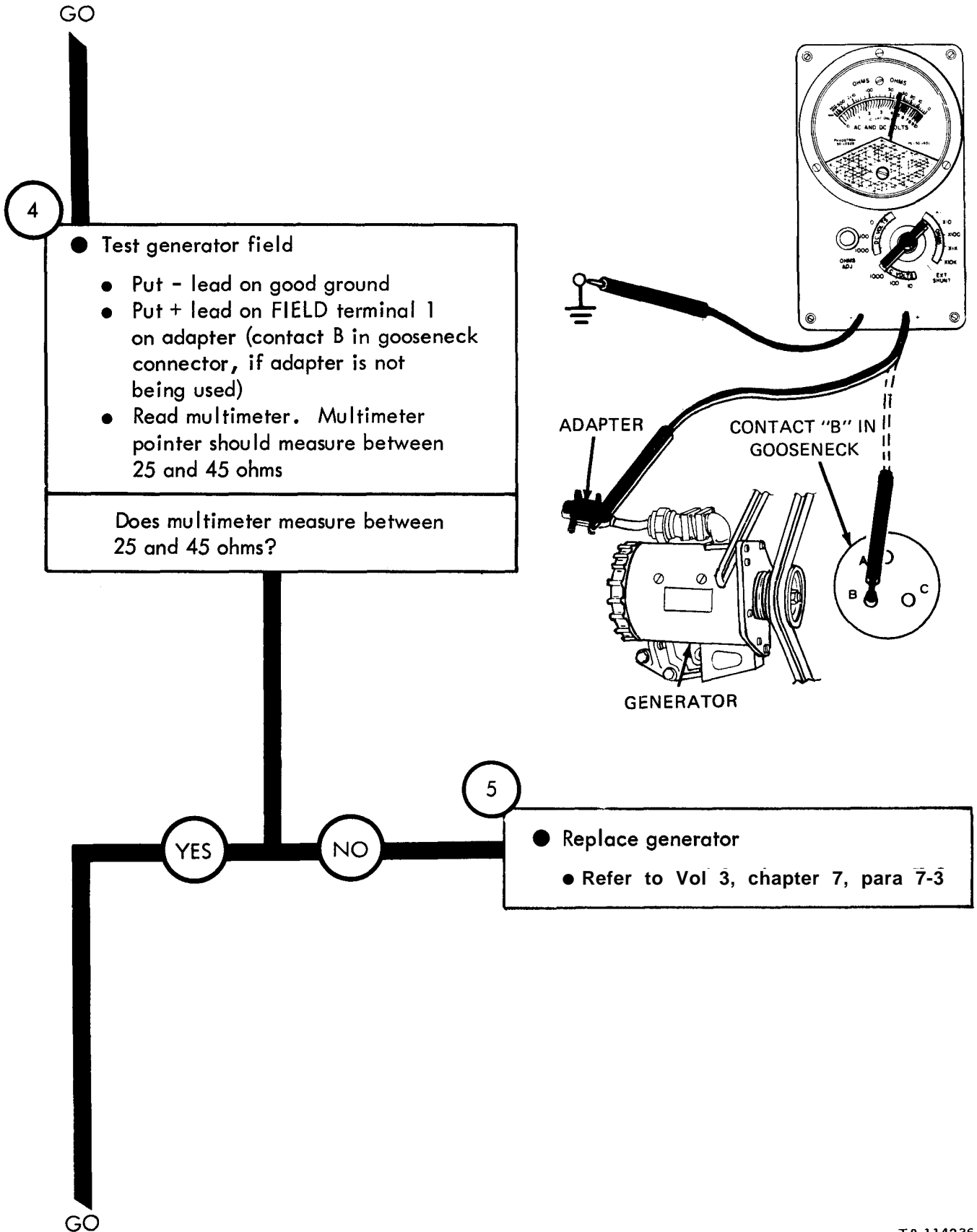
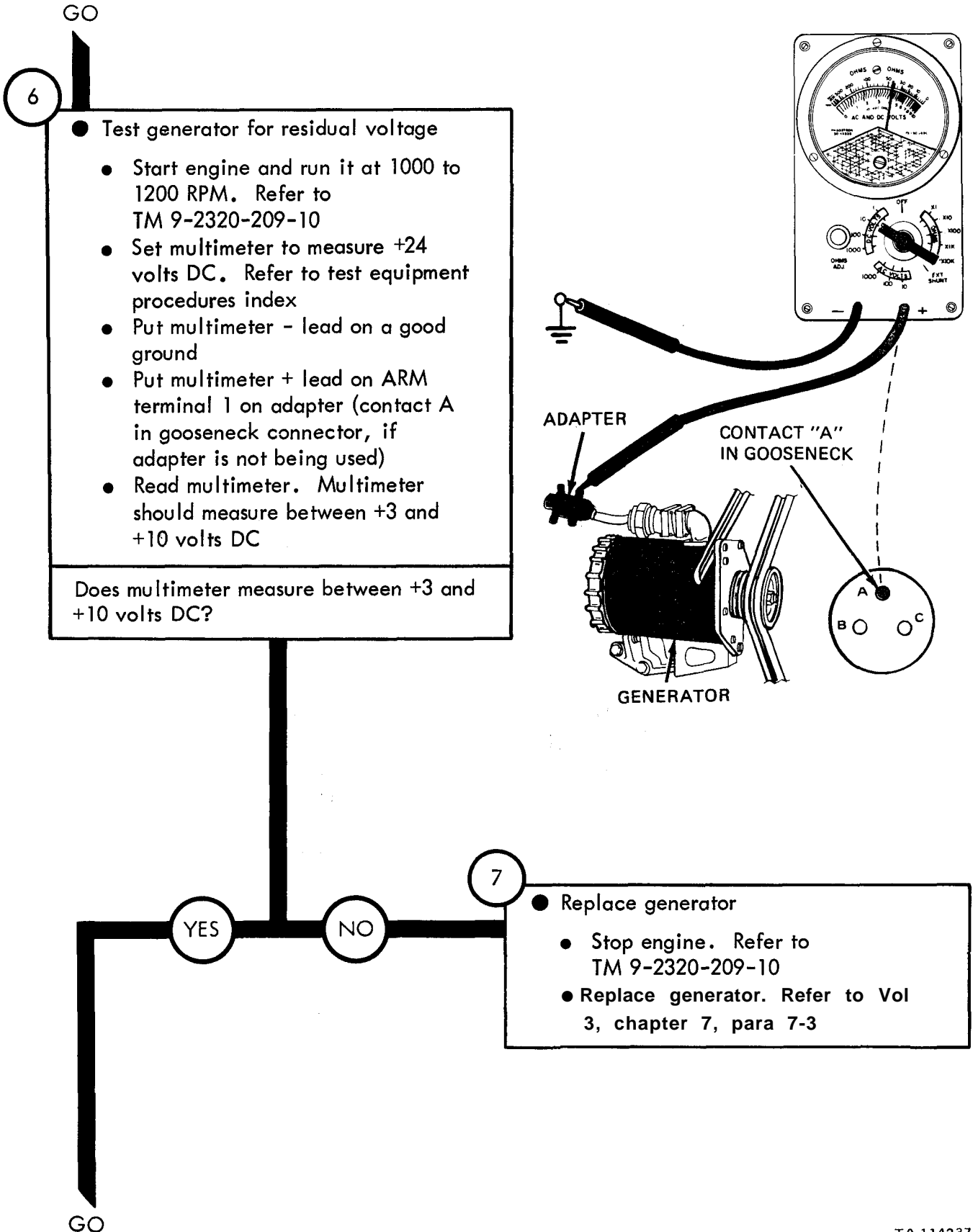

Figure 25-2 (Sheet 3 of 13)



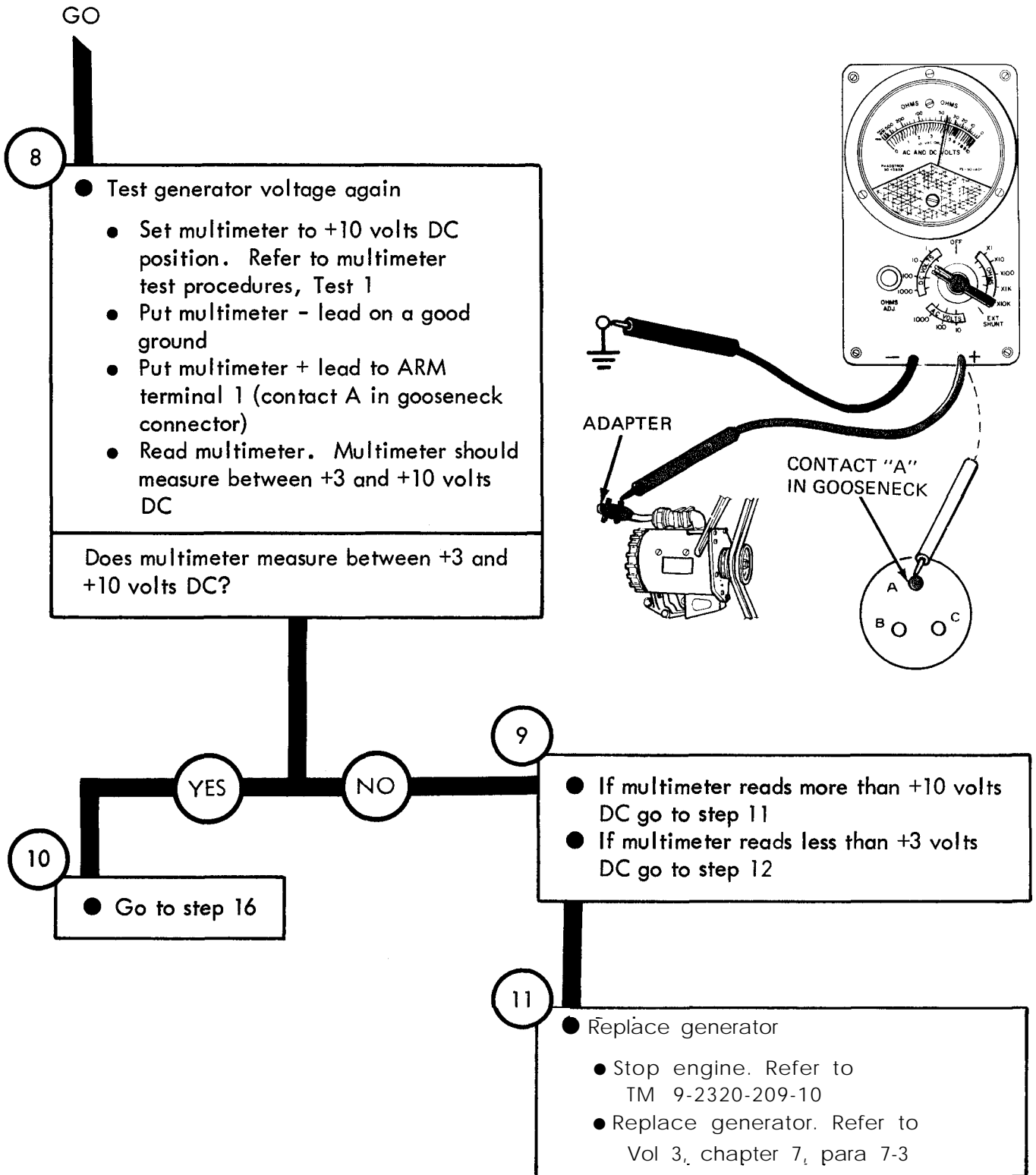
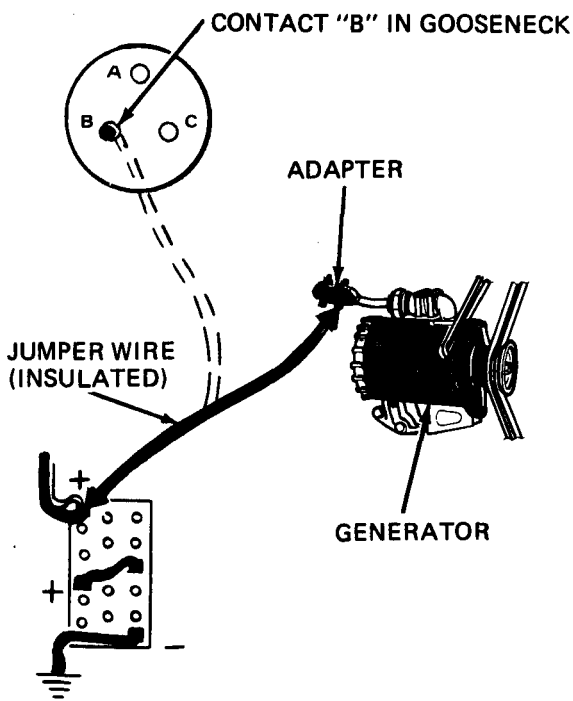

Figure 25-2 (Sheet 5 of 13)



From step 9

12

- Flash generator field terminal
 - Stop engine. Refer to TM 9-2320-209-10
 - Put one end of an insulated jumper wire on + terminal of battery
 - Touch and quickly take away other end of jumper wire from Field terminal 1 (contact B in gooseneck connector)
 - Take insulated jumper wire off + battery terminal

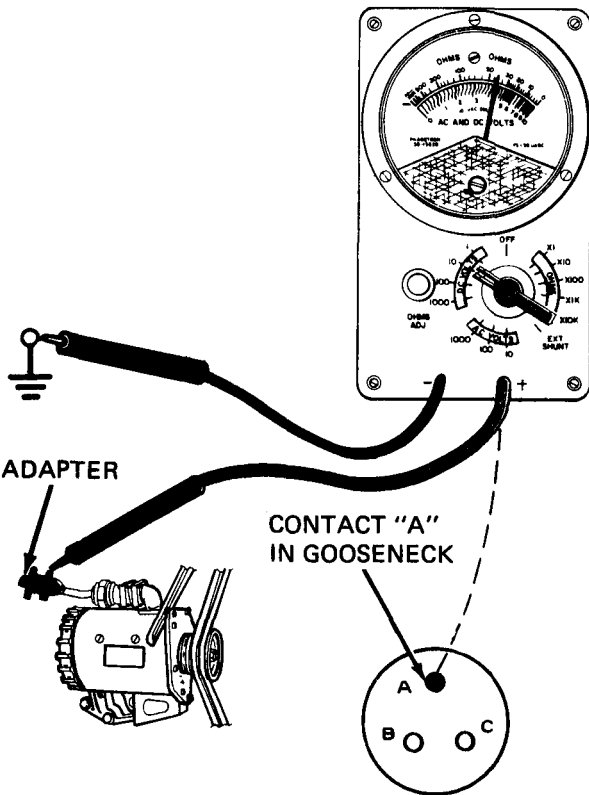

13

- Test generator for +3 to +10 volts DC
 - Start engine and run at 1000 to 1200 RPM. Refer to TM 9-2320-209-10
 - Put multimeter - lead on a good ground
 - Put multimeter + lead on ARM terminal 1 (contact A in generator gooseneck)
 - Read multimeter. Multimeter should measure between +3 and +10 volts DC

Does multimeter read between +3 and +10 volts DC?

NO GO

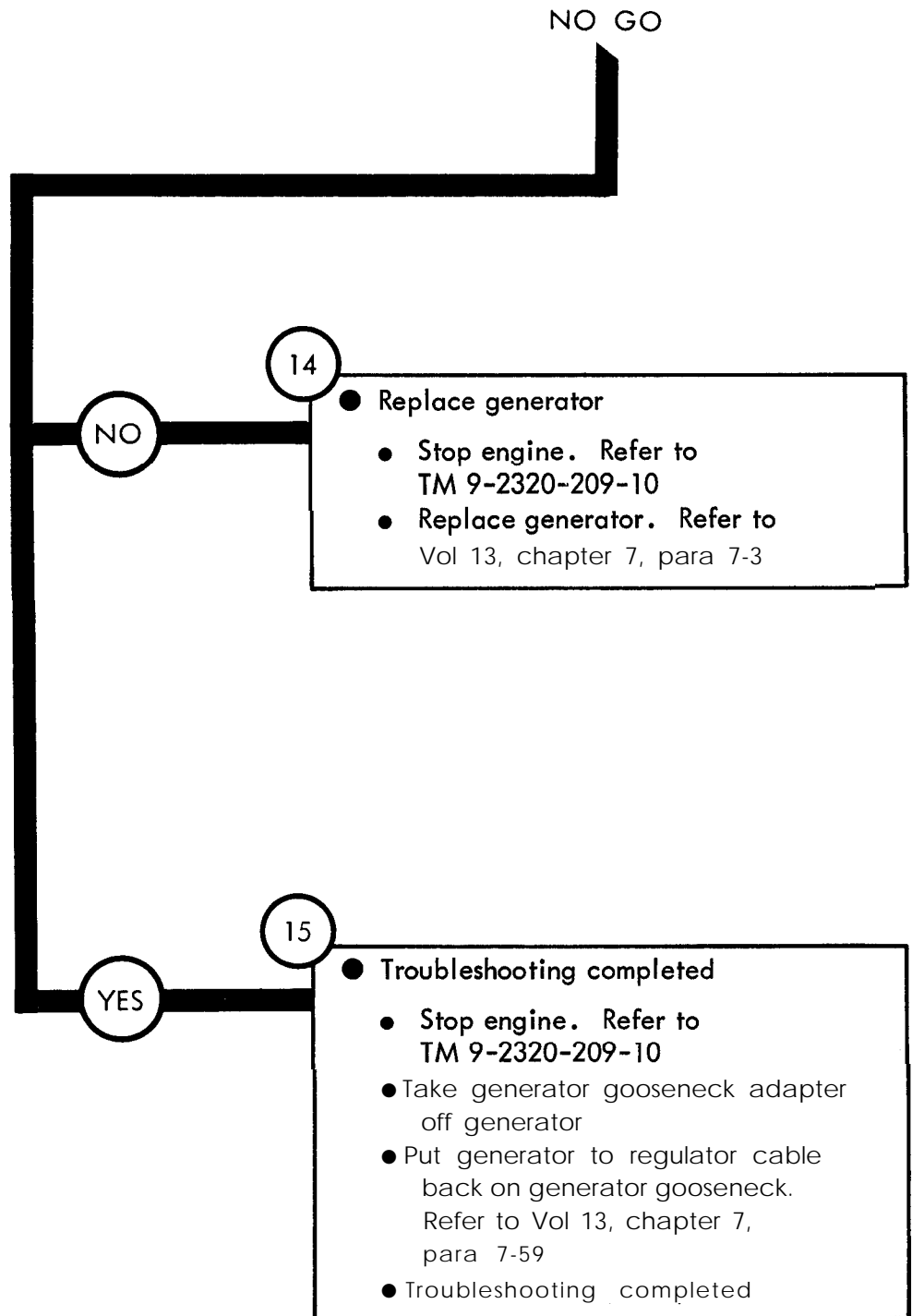
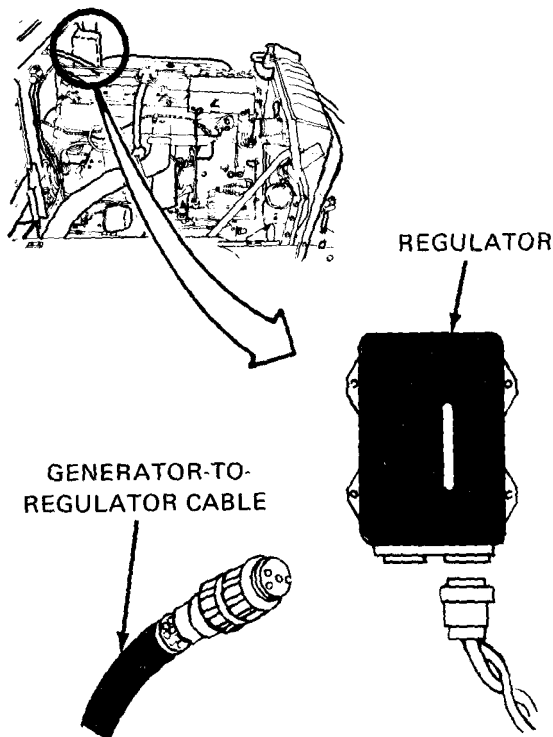

Figure 25-2 (Sheet 7 of 13)

From step 10

16

- Check generator to regulator cable for continuity
- Stop engine. Refer to TM 9-2320-209-10
- Take generator to regulator cable off at regulator. Refer to Vol 3, chapter 7, para 7-59
- Set multimeter to check continuity. Refer to test equipment procedues index



- Put multimeter + lead on generator end of cable contact A
- Put multimeter - lead on regulator end of cable contact A. Read multimeter. Multimeter should measure zero ohms
- Put multimeter + lead on generator end of cable contact B
- Put multimeter - lead on regulator end of cable contact B. Read multimeter. Multimeter should measure 0 ohms

Did multimeter measure zero ohms for both tests?

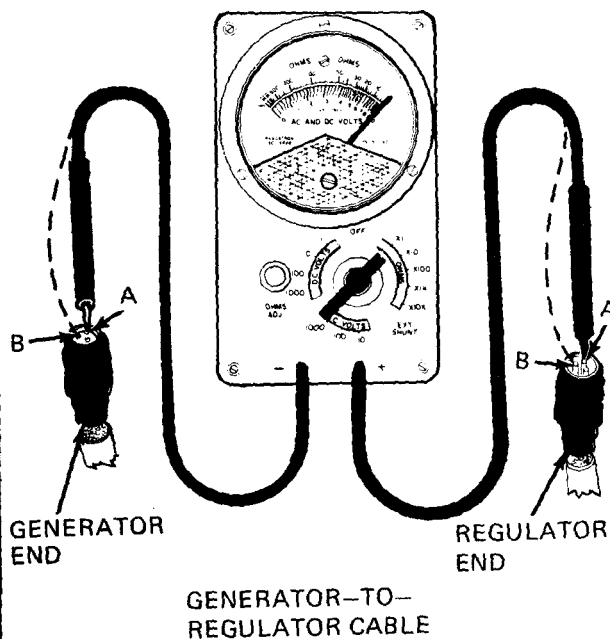

GO

TA 11424

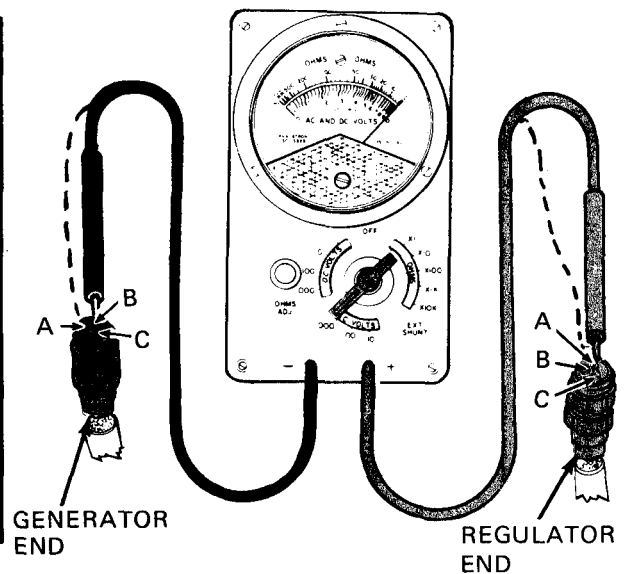
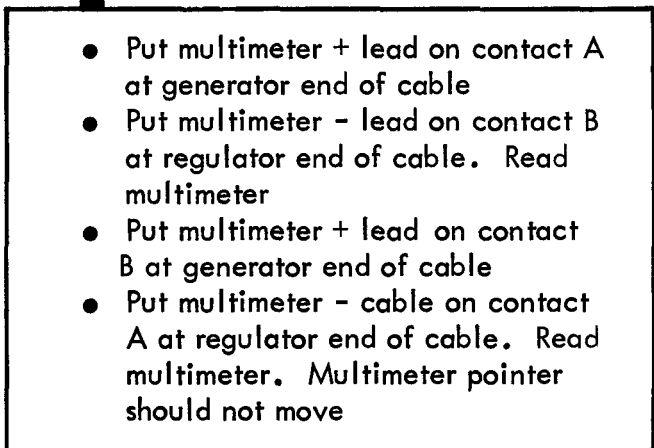
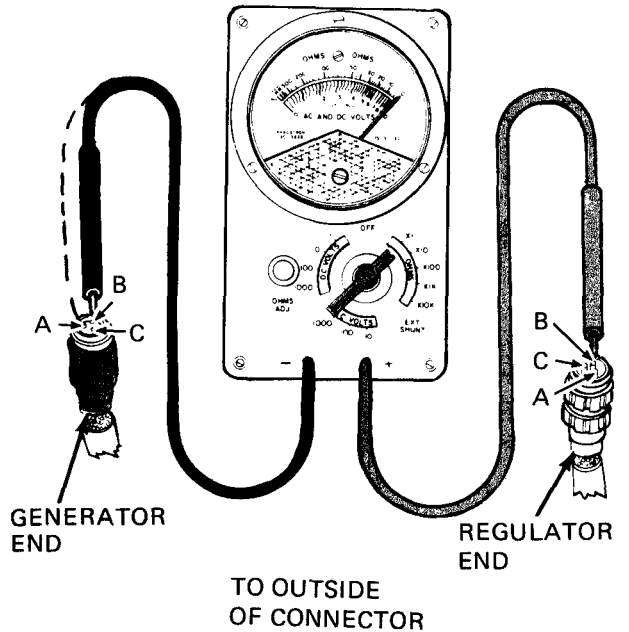
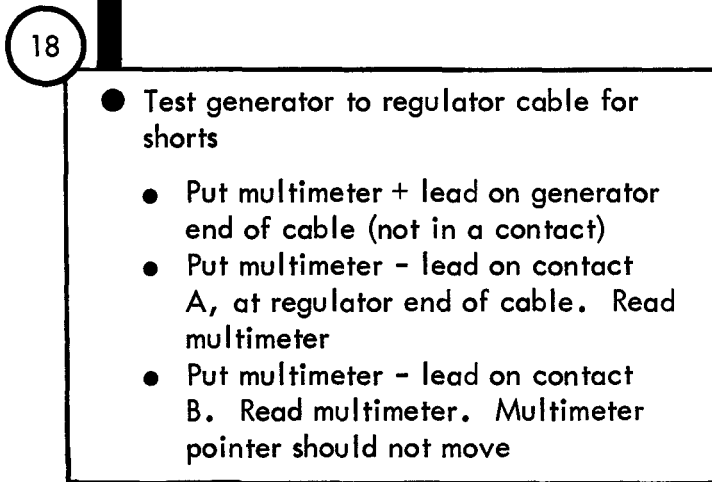
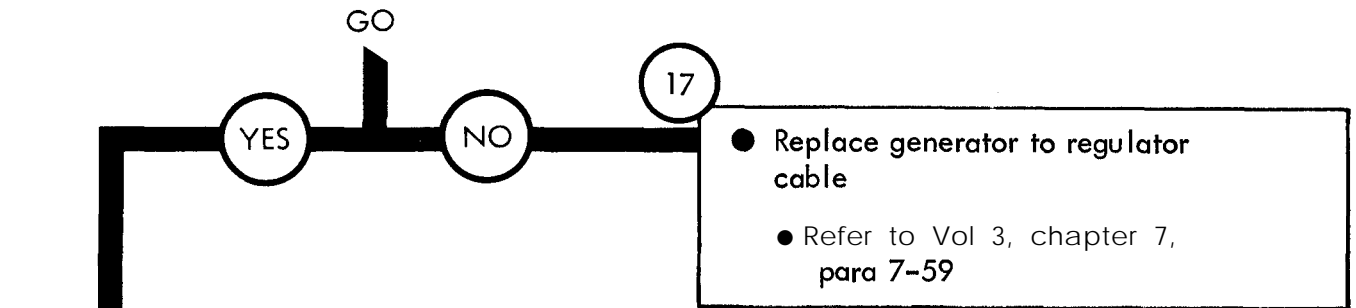

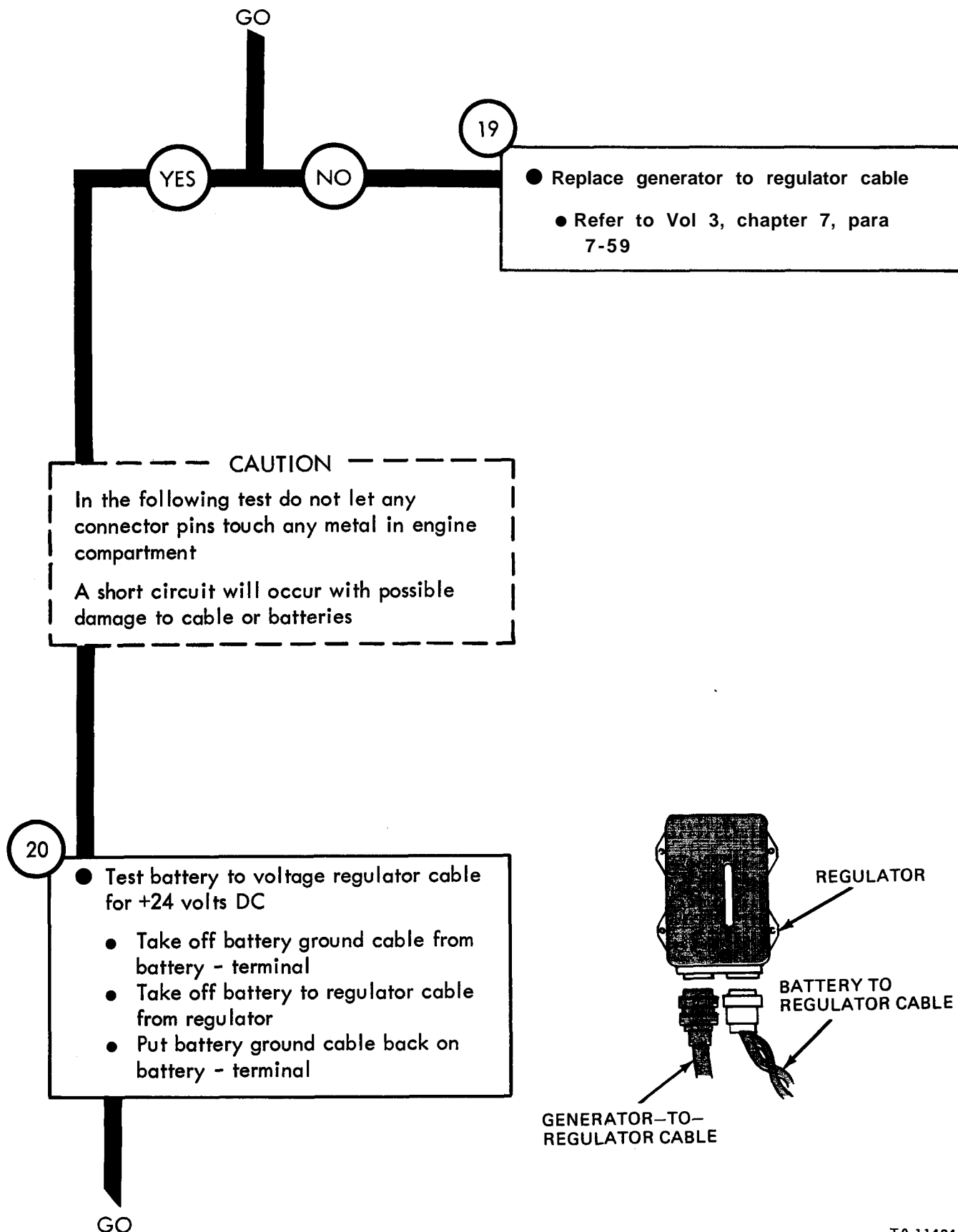

TA 114243

Figure 25-2 (Sheet 10 of 13)

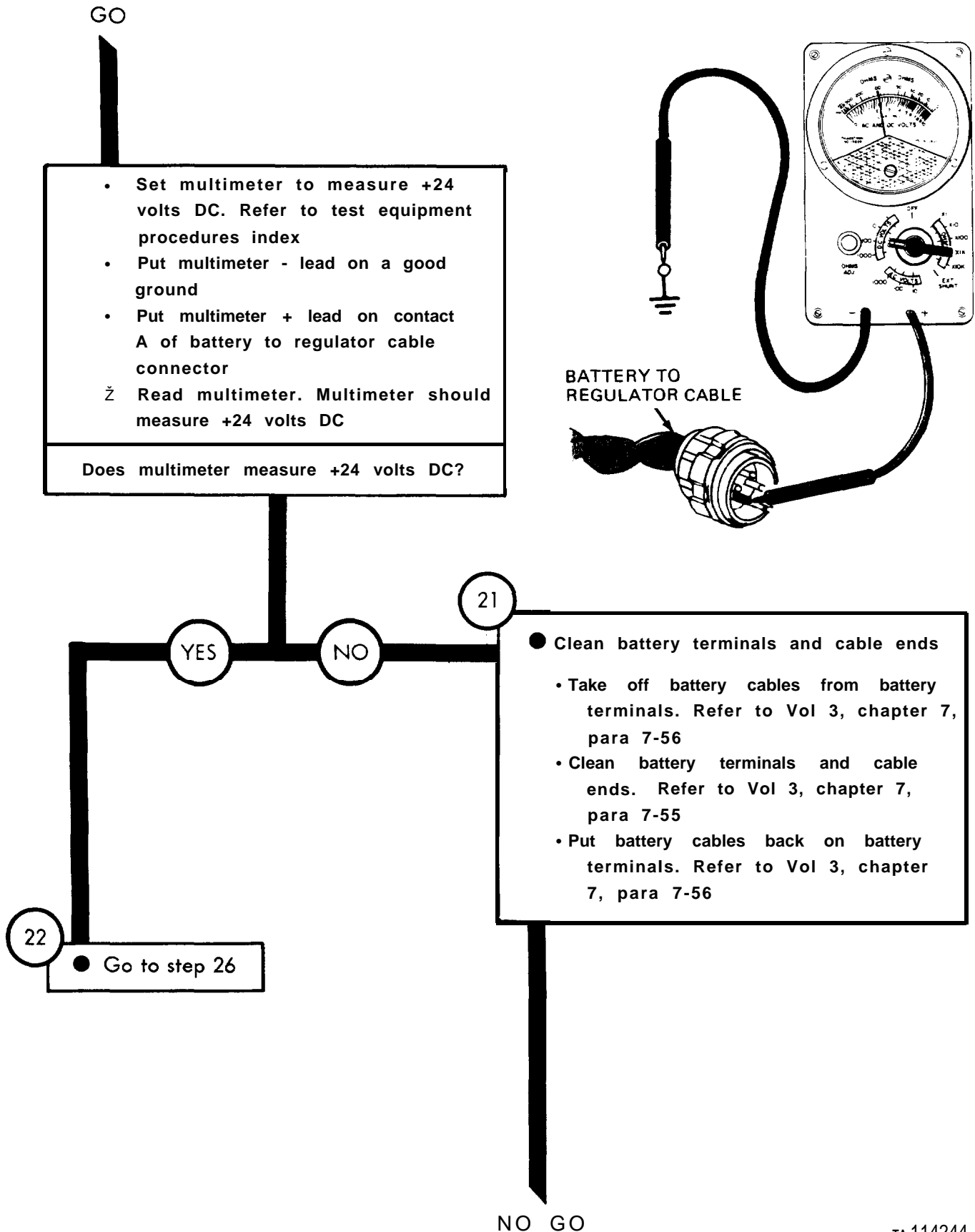
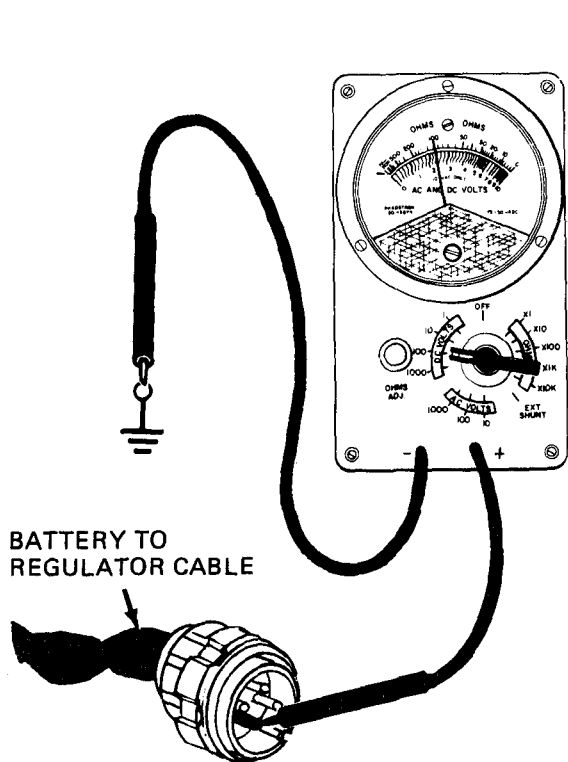

Figure 25-2 (Sheet 11 of 13)



NO GO

23

- Recheck battery to regulator cable for +24 volts DC
- Put multimeter - lead on a good ground
- Put multimeter + lead on contact A of battery to regulator cable
- Read multimeter. Multimeter should measure +24 volts DC

Does multimeter measure +24 volts DC?

NO

24

- Replace battery to regulator cable
- Put generator to regulator cable on generator gooseneck connector and regulator. Refer to Vol 3, chapter 7, para 7-59
- Replace battery to regulator cable. Refer to Vol 3, chapter 7, para 7-56 and 7-5

NO GO

TA 114245

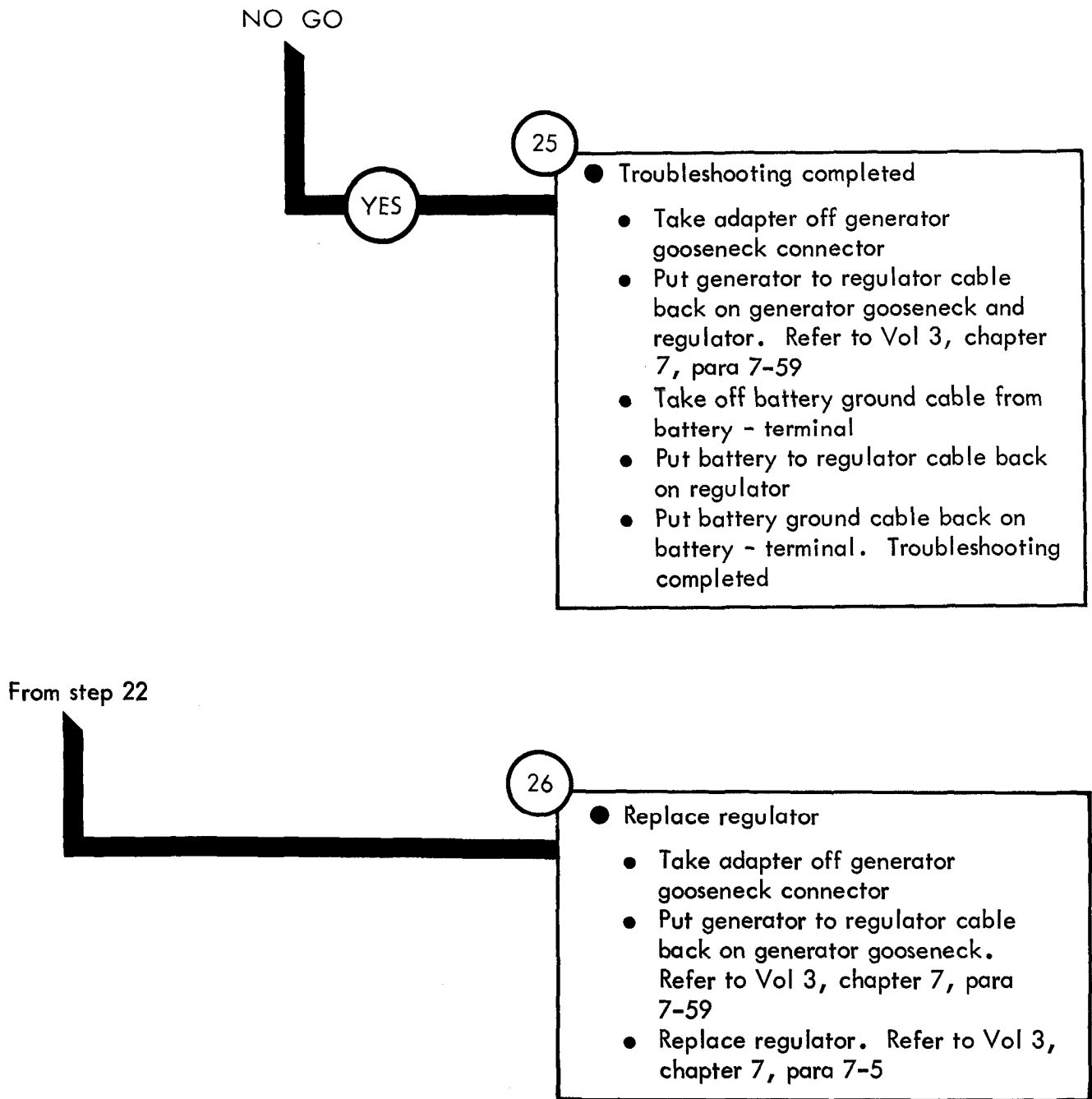

Symptom

3

CHARGING SYSTEM (60 AMP, ALTERNATOR) HAS TOO HIGH OR LOW CHARGING RATE

CAUTION

Never polarize an alternator. Reverse polarization can occur with permanent damage to alternator

NOTE

Make all charging system checks after running engine until engine compartment is hot

When measuring voltage +24 volts DC means a range of +23 to +26 volts DC and +28 volts DC a range of +27 to +28.5 volts DC

1

- Park truck
- Refer to TM 9-2320-209-10

GO

GO

2

- Test alternator field cable 1 for +24 volts DC
 - Take alternator field cable 1 disconnect plug off field cable 1 receptacle
 - Set ACCESSORY switch to ON. (Do not start engine)
 - Set multimeter to measure +24 volts DC. Refer to test equipment procedures index
 - Put multimeter - lead on a good ground
 - Put multimeter + lead in field cable 1 receptacle. Read multimeter. Multimeter should measure +24 volts DC

Does multimeter measure +24 volts DC?

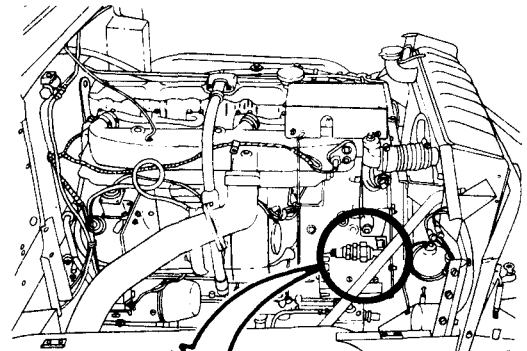

ALTERNATOR
60 AMP

TERMINAL
COVER

ALTERNATOR
FIELD CABLE
1 PLUG

ALTERNATOR
OUTPUT
CABLE 2

ALTERNATOR
FIELD CABLE 1
RECEPTACLE

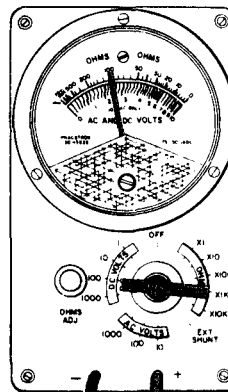

GO

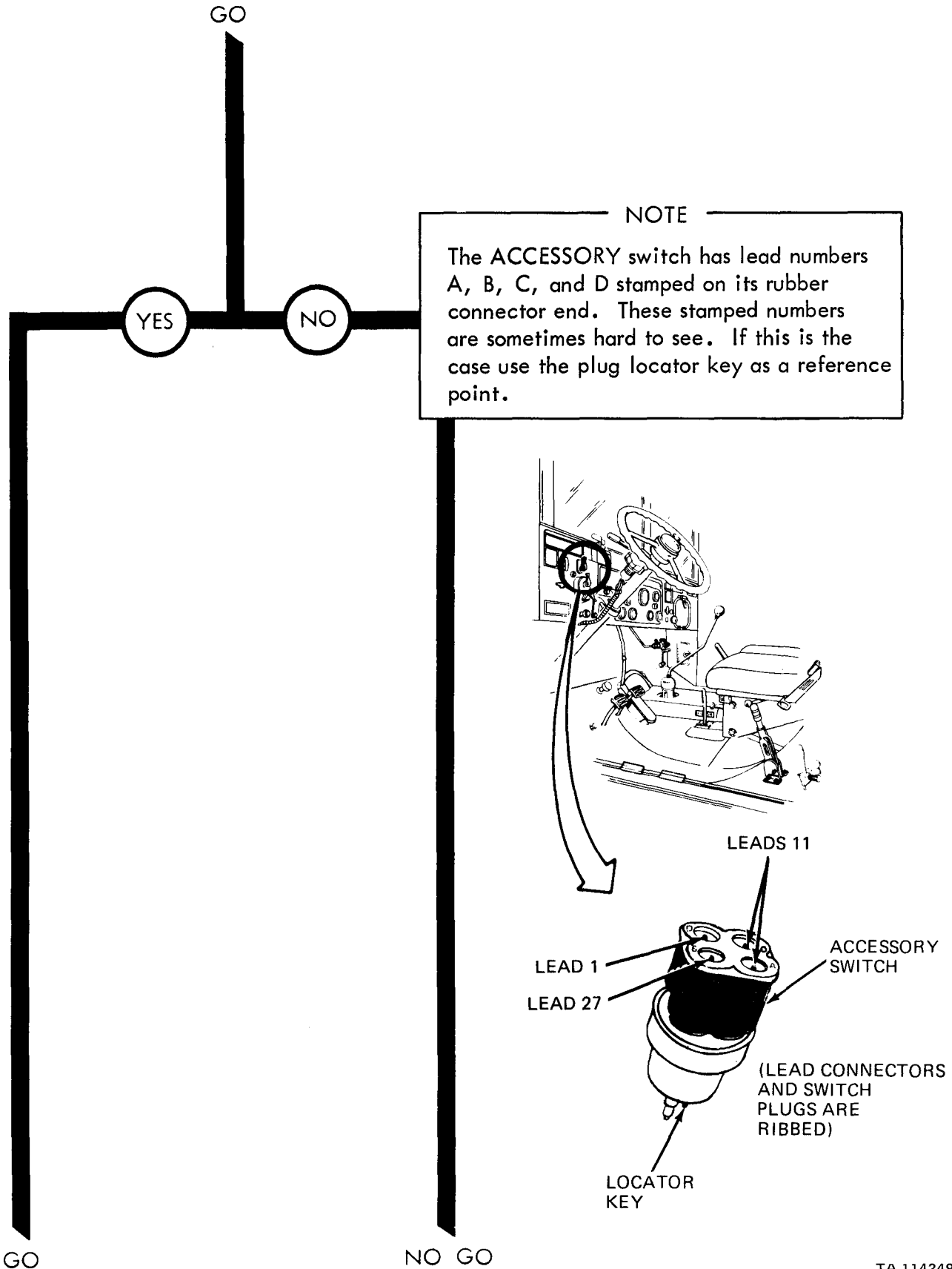

TA 114249

GO

NO GO

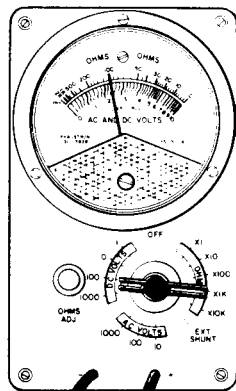
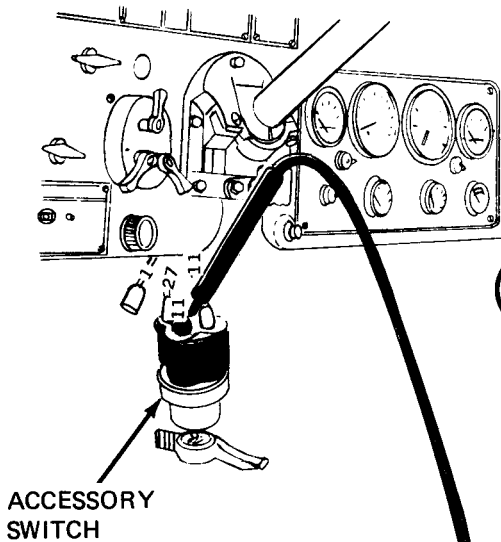

3

- Test for voltage at ACCESSORY switch
 - Set ACCESSORY switch to OFF
 - Take ACCESSORY switch off instrument panel. Refer to Vol 3, chapter 7, para 7-15
 - Put ACCESSORY switch lever back on ACCESSORY switch
 - Take off lead 1 from ACCESSORY switch

- Put multimeter - lead on a good ground
- Put multimeter + lead in contact D of ACCESSORY switch
- Read multimeter. Multimeter should measure zero volts DC

Does multimeter measure zero volts DC?

GO

NO GO

TA 114250

Figure 25-3 (Sheet 4 of 14)

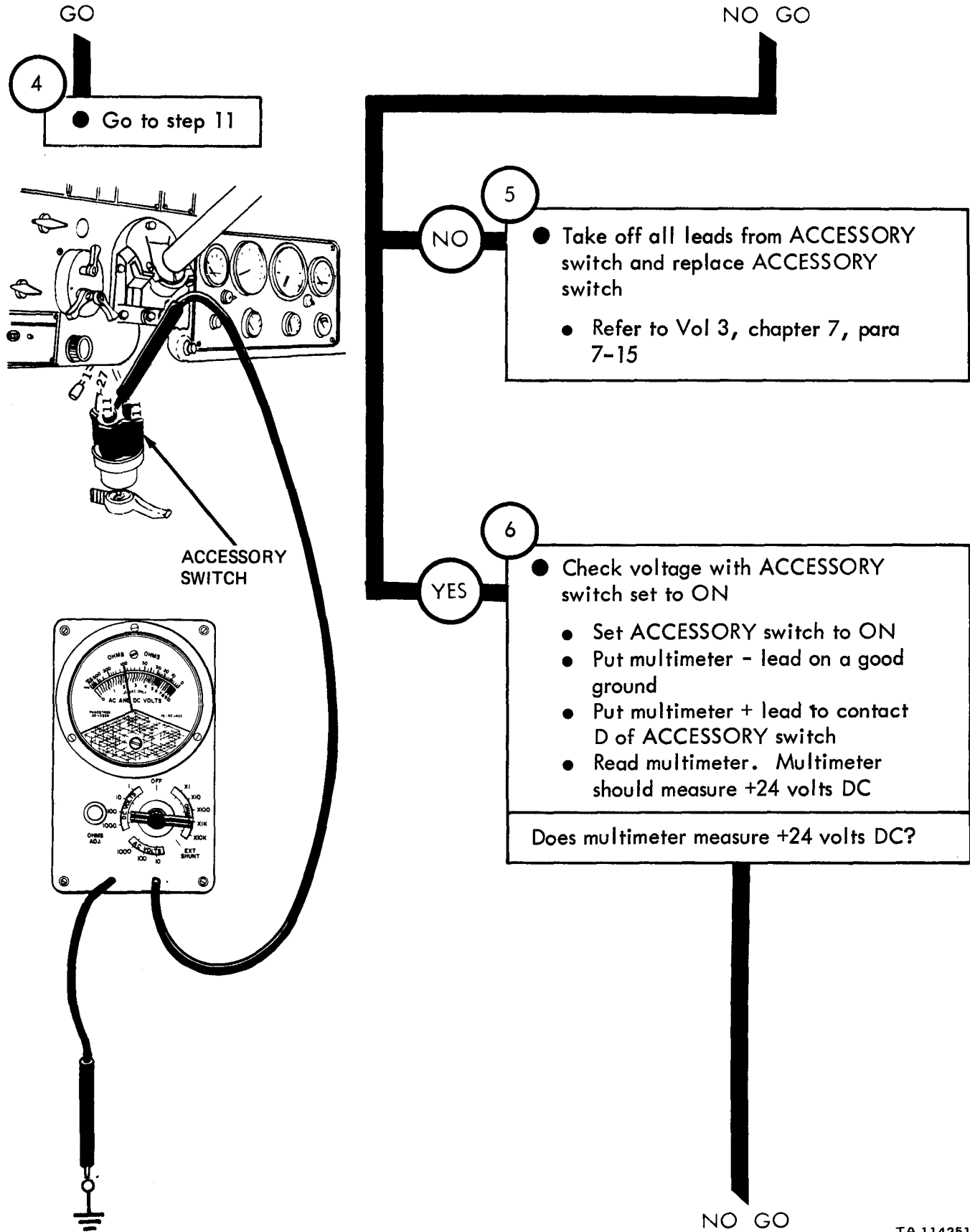

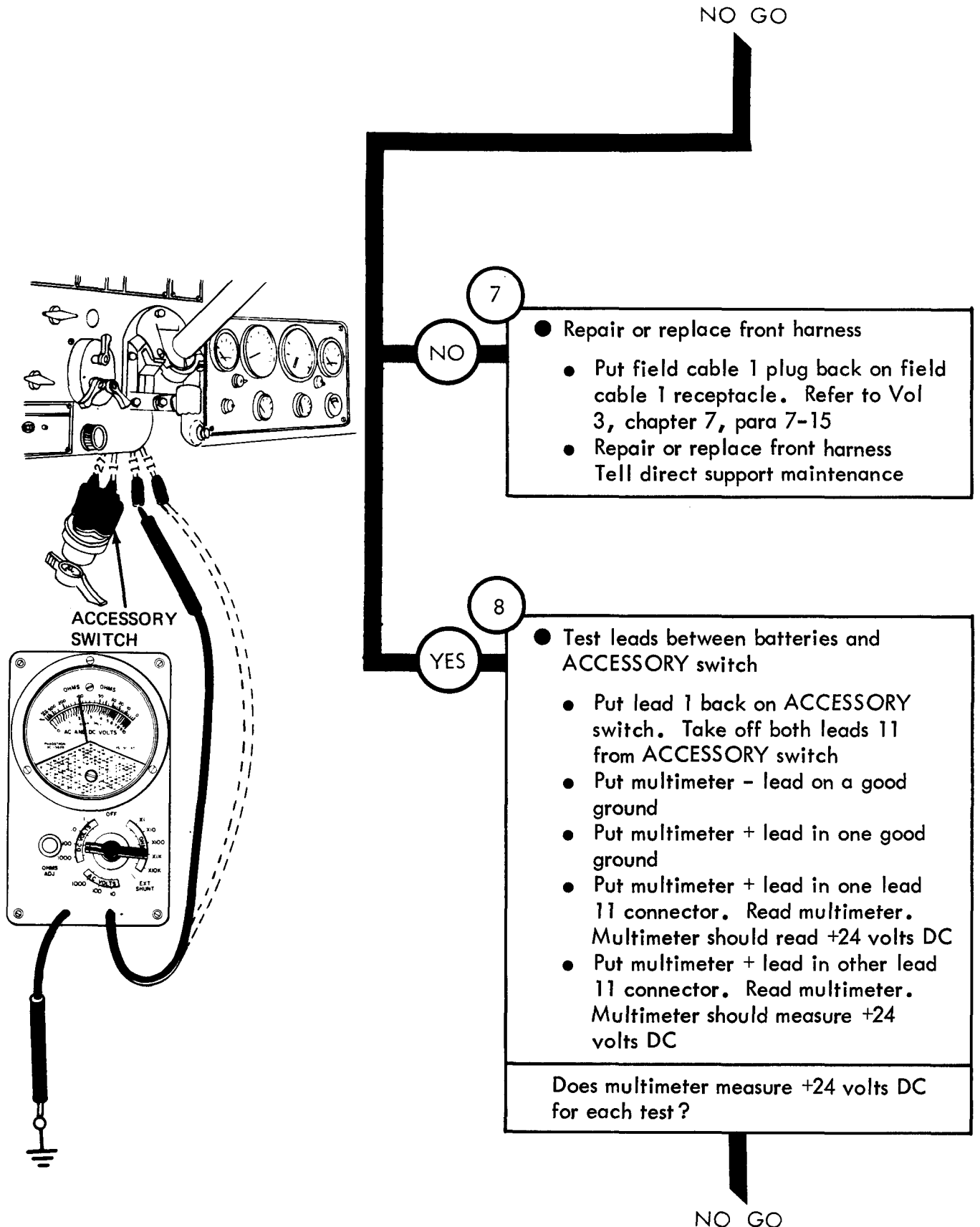

7

- Repair or replace front harness
 - Put field cable 1 plug back on field cable 1 receptacle. Refer to Vol 3, chapter 7, para 7-15
 - Repair or replace front harness Tell direct support maintenance

8

- Test leads between batteries and ACCESSORY switch
 - Put lead 1 back on ACCESSORY switch. Take off both leads 11 from ACCESSORY switch
 - Put multimeter - lead on a good ground
 - Put multimeter + lead in one good ground
 - Put multimeter + lead in one lead 11 connector. Read multimeter. Multimeter should read +24 volts DC
 - Put multimeter + lead in other lead 11 connector. Read multimeter. Multimeter should measure +24 volts DC

Does multimeter measure +24 volts DC for each test?

Figure 25-3 (Sheet 6 of 14)

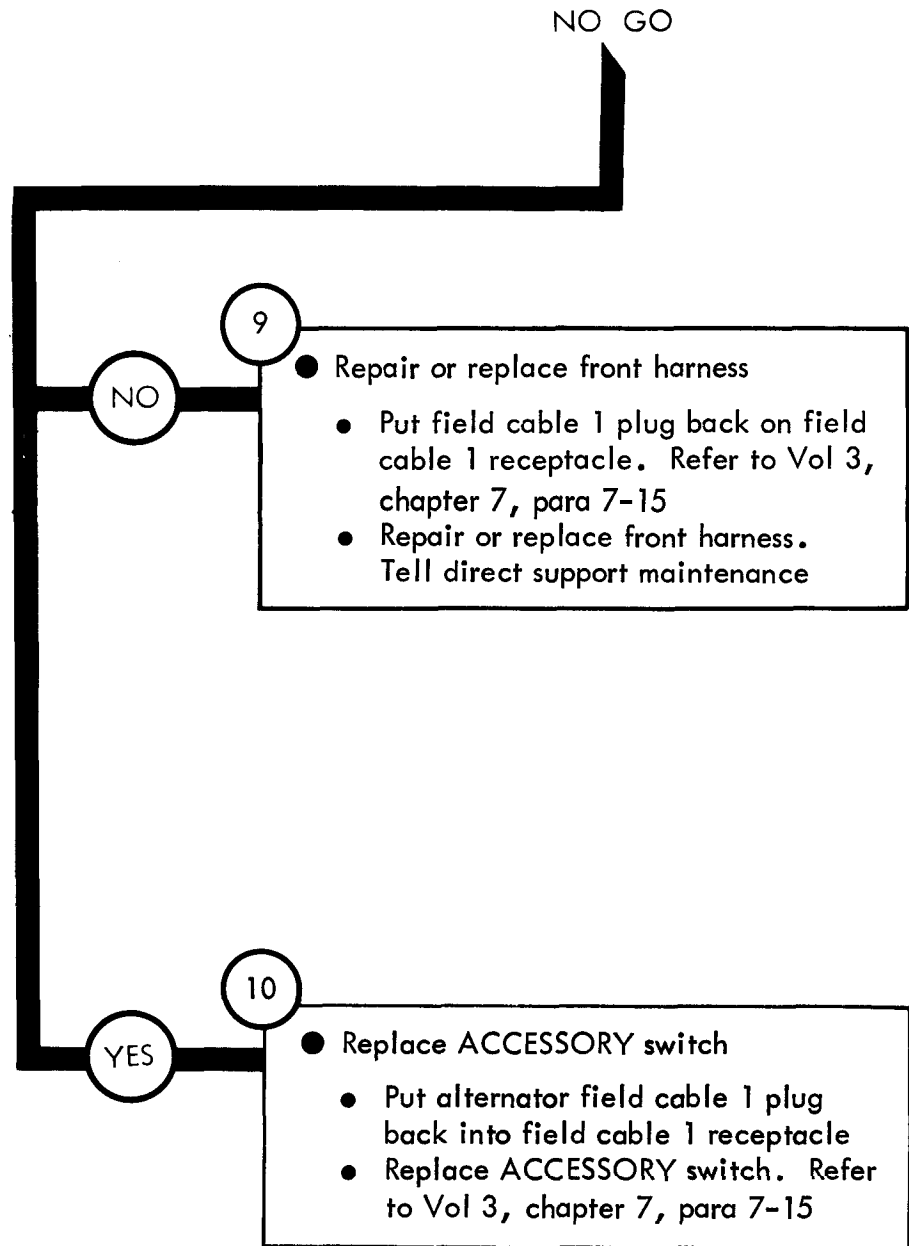

Figure 25-3 (Sheet 7 of 14)

From step 4

11

- Check for +28 volts DC at alternator output terminal (stator)
 - Put alternator field cable 1 disconnect plug on field cable 1 receptacle
 - Take off battery ground cable from battery - terminal. Refer to Vol 3, chapter 7, para 7-58
 - Take off alternator terminal cover

- Put battery ground cable back on battery - terminal
- Start engine. Refer to TM9-2320-209-10
- Put multimeter - lead on a good ground
- Put multimeter + lead on alternator output terminal. Do not touch cable 2 connector. Read multimeter. Multimeter should measure +28 volts DC

Does multimeter measure +28 volts DC?

GO

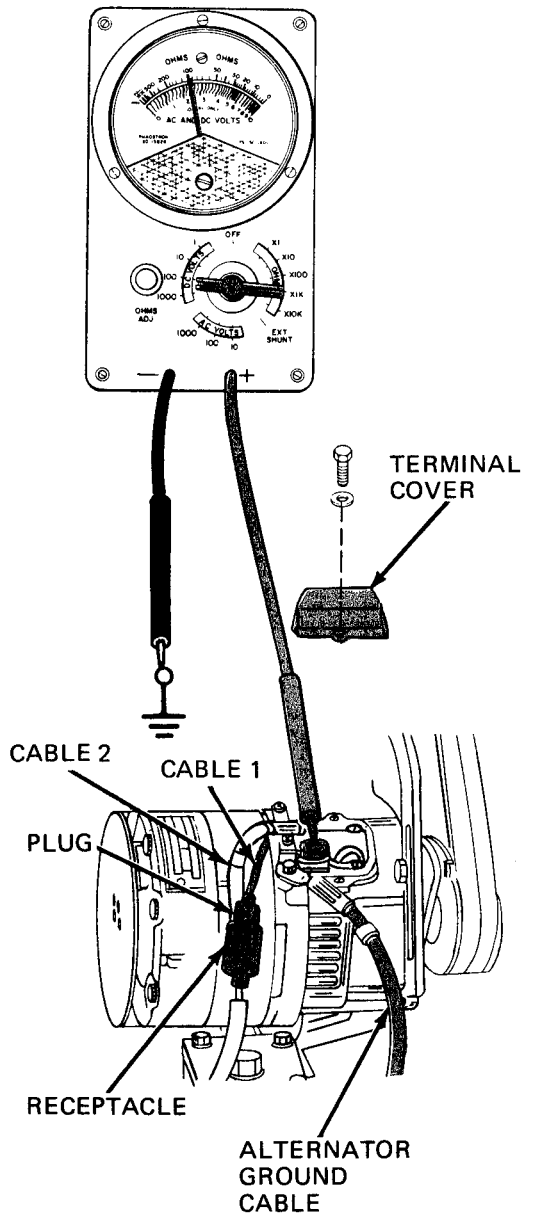

Figure 25-3 (Sheet 8 of 14)

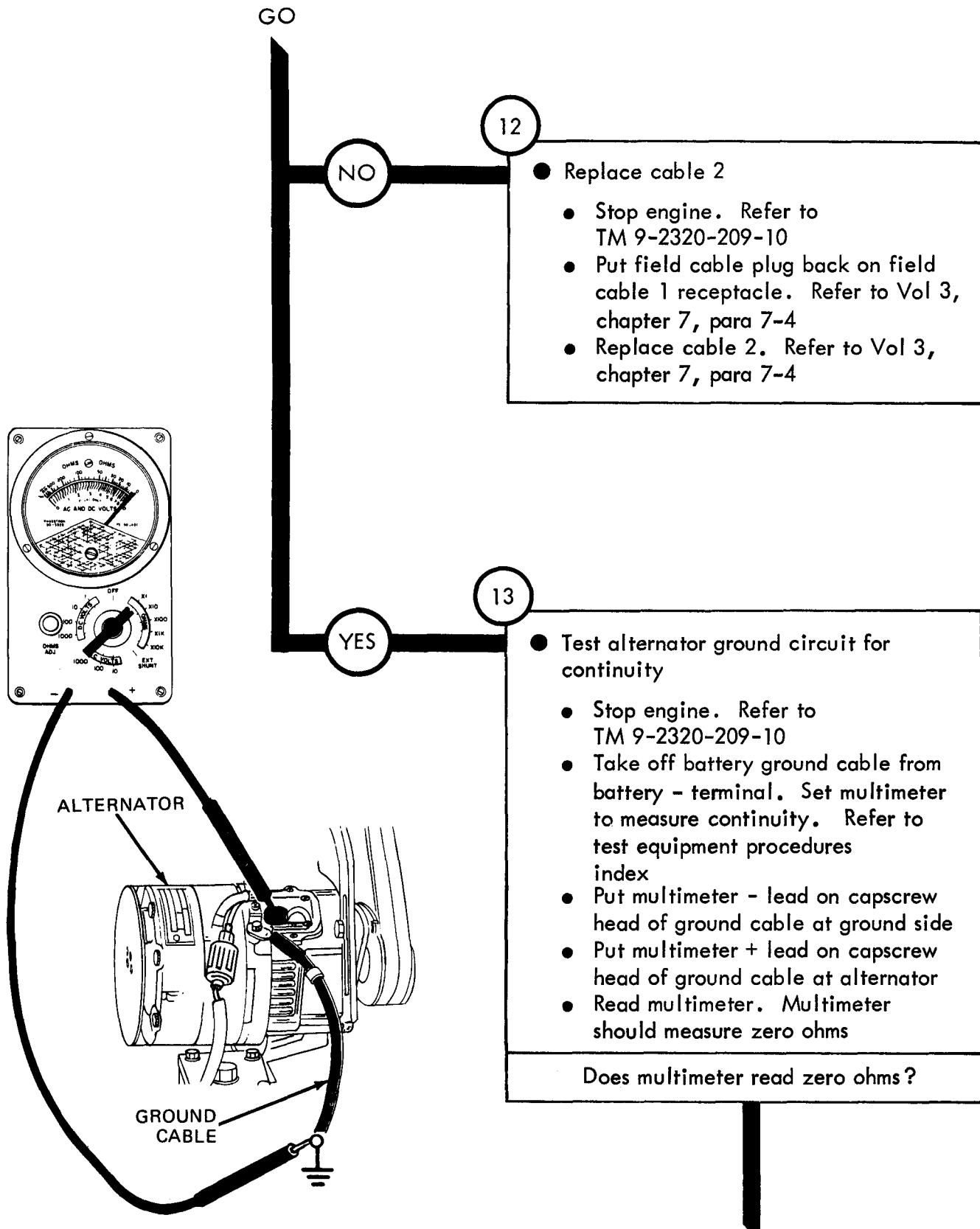

Figure 25-3 (Sheet 9 of 14)

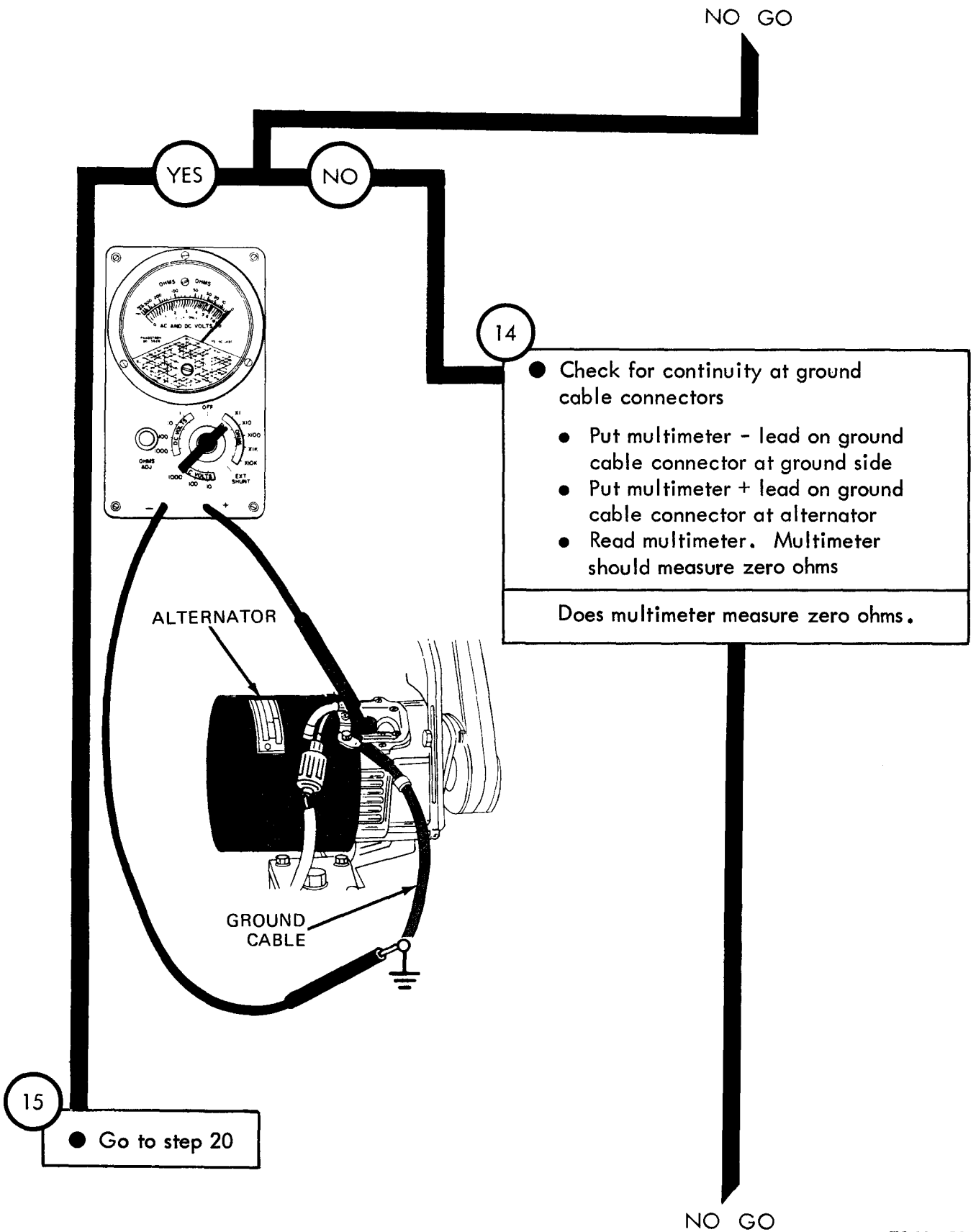
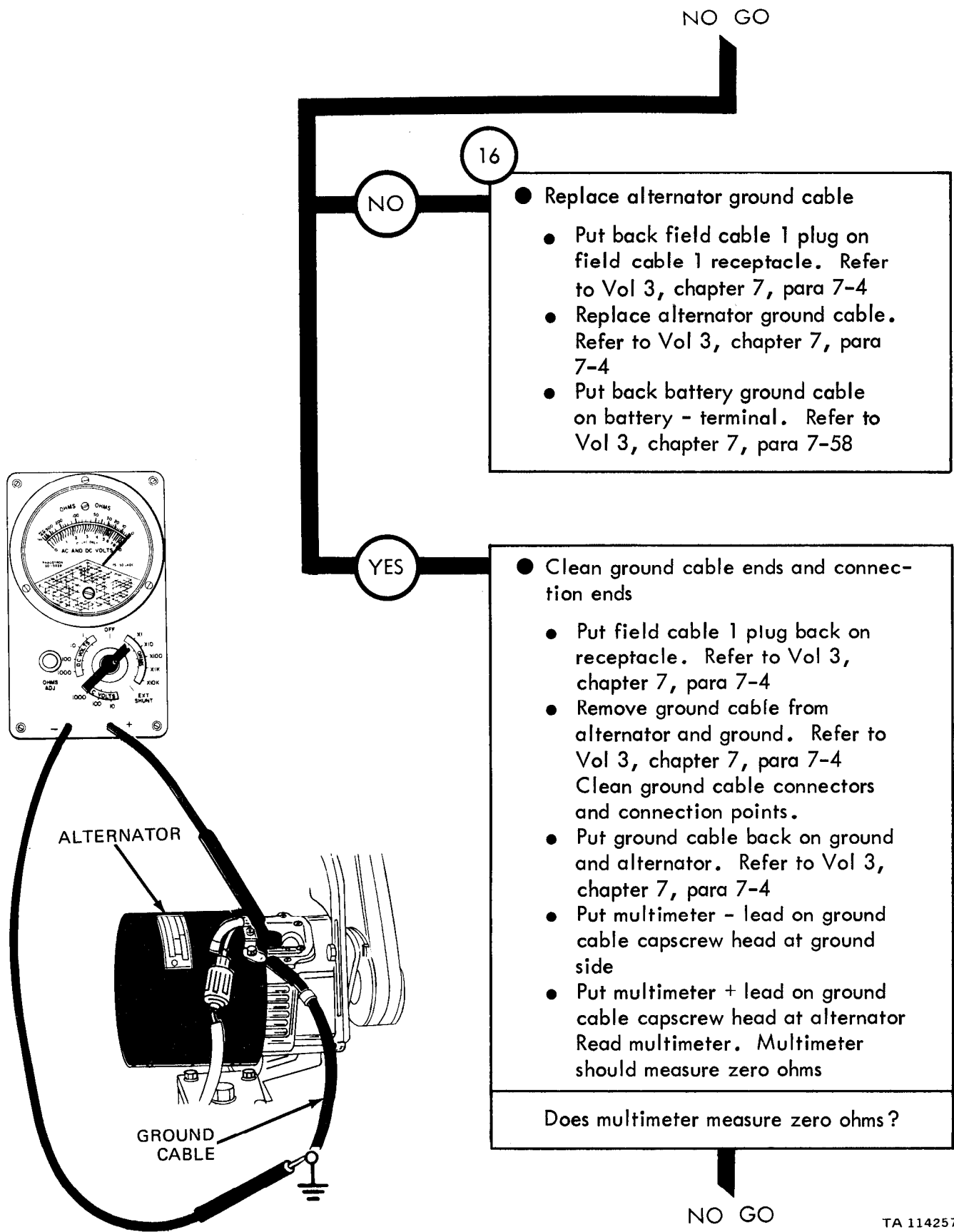

Figure 25-3 (Sheet 10 of 14)

TA 114256



TA 114257

Figure 25-3 (Sheet 11 of 14)

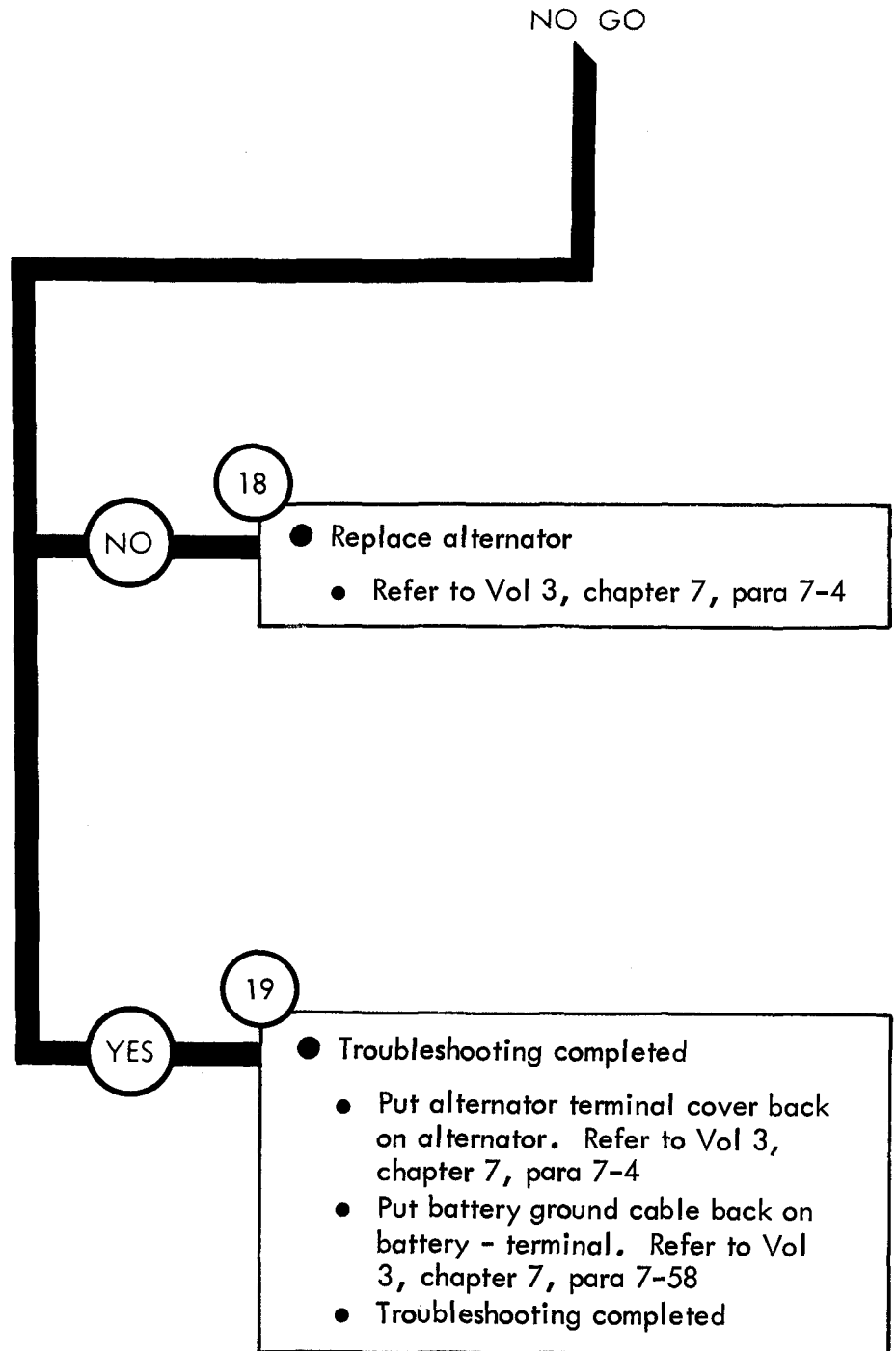

TA 114258

Figure 25-3 (Sheet 12 of 14)

From step 15

20

- Test and adjust alternator output
 - Put field cable 1 plug back on field cable 1 receptacle. Refer to Vol 3, chapter 7, para 7-4
 - Put battery ground cable back on battery - terminal. Refer to Vol 3, chapter 7, para 7-58
 - Start engine and run at 1000 to 1200 RPM (engine warm). If not warm run for 15 minutes before finishing test. Refer to TM 9-2320-209-10

- Set multimeter to measure +28 volts DC. Refer to test equipment procedures index
- Put multimeter - lead on a good ground
- Put multimeter + lead on alternator output (positive) terminal
- Read multimeter. Multimeter should measure +28 volts DC

GO

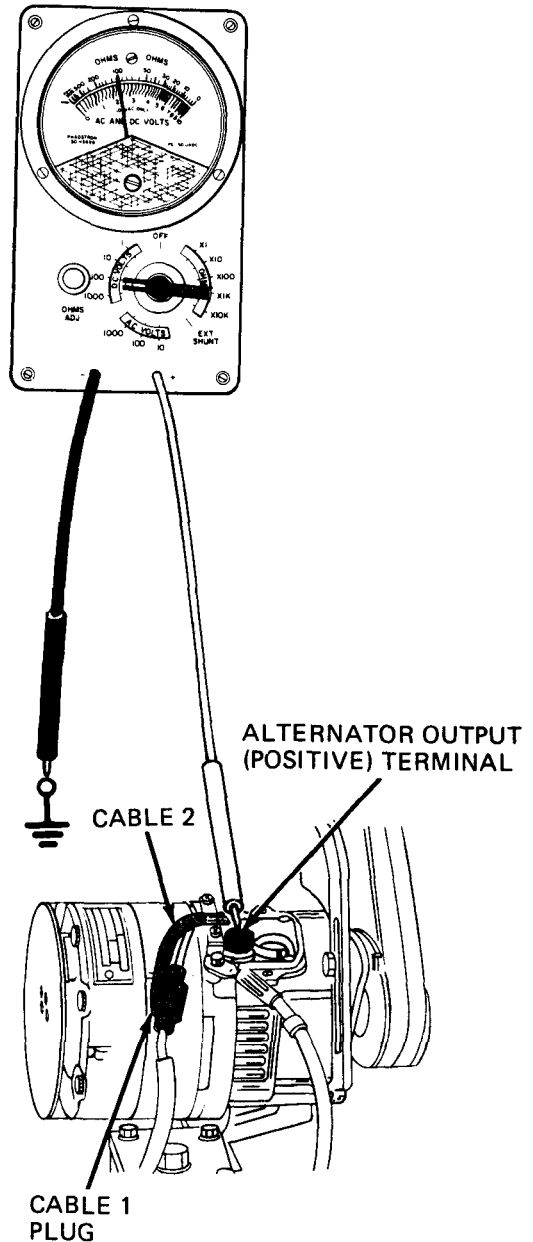

GO

21

- If multimeter does not measure +28 volts DC adjust alternator
 - Locate voltage adjustment screw on alternator. It will be identified at either front or back of alternator as VOLT ADJUST
 - Remove pipe plug that covers voltage adjustment screw
 - Turn adjustment screw left or right to raise or lower voltage until you get a 28 volt DC multimeter reading

Did you get a +28 volt DC reading?

ALTERNATOR

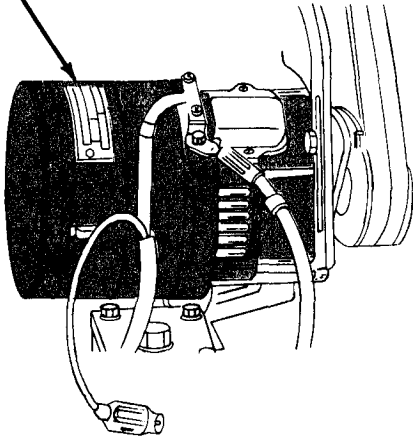

NO

22

- Replace alternator
 - Stop engine. Refer to TM 9-2320-209-10
 - Replace alternator. Refer to Vol 3, chapter 7, para 7-4

YES

23

- Troubleshooting completed
 - Stop engine. Refer to TM 9-2320-209-10
 - Troubleshooting completed

Figure 25-3 (Sheet 14 of 14)

Symptom

4 BATTERIES GO DEAD WHEN TRUCK IS PARKED OVERNIGHT OR A PERIOD OF DAYS

NOTE

First check that ACCESSORY switch and lights were not left on
Recharge or replace batteries before making any test. Refer to Vol 3, chapter 7, para 7-56

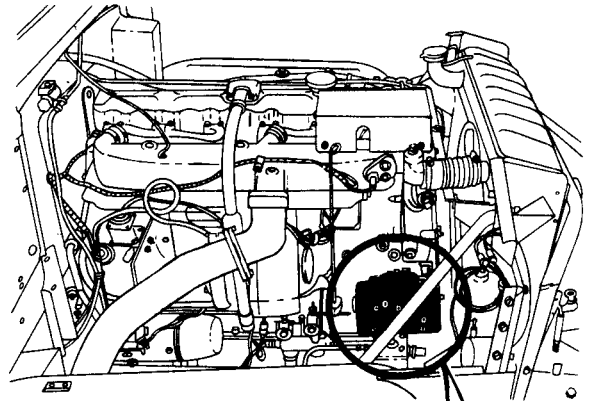

1

- Park truck
 - Refer to TM9-2320-209-10
 - Start engine and run at 1000 to 1200 RPM until warm. Refer to TM9-2320-209-10

2

- If you are testing a generator go to step 3
- If you are testing an alternator go to step 6

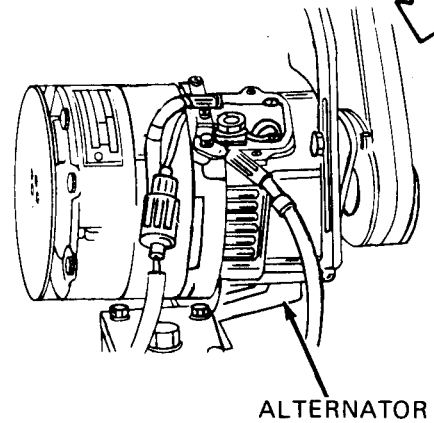
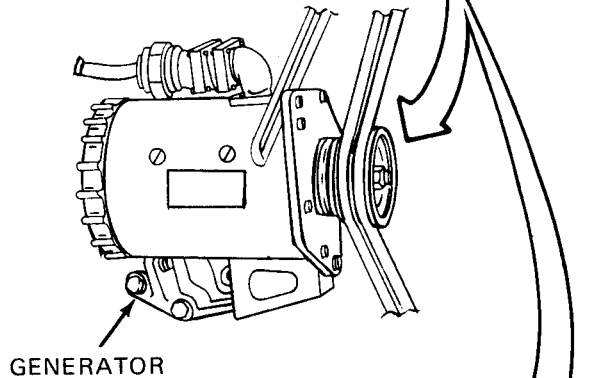
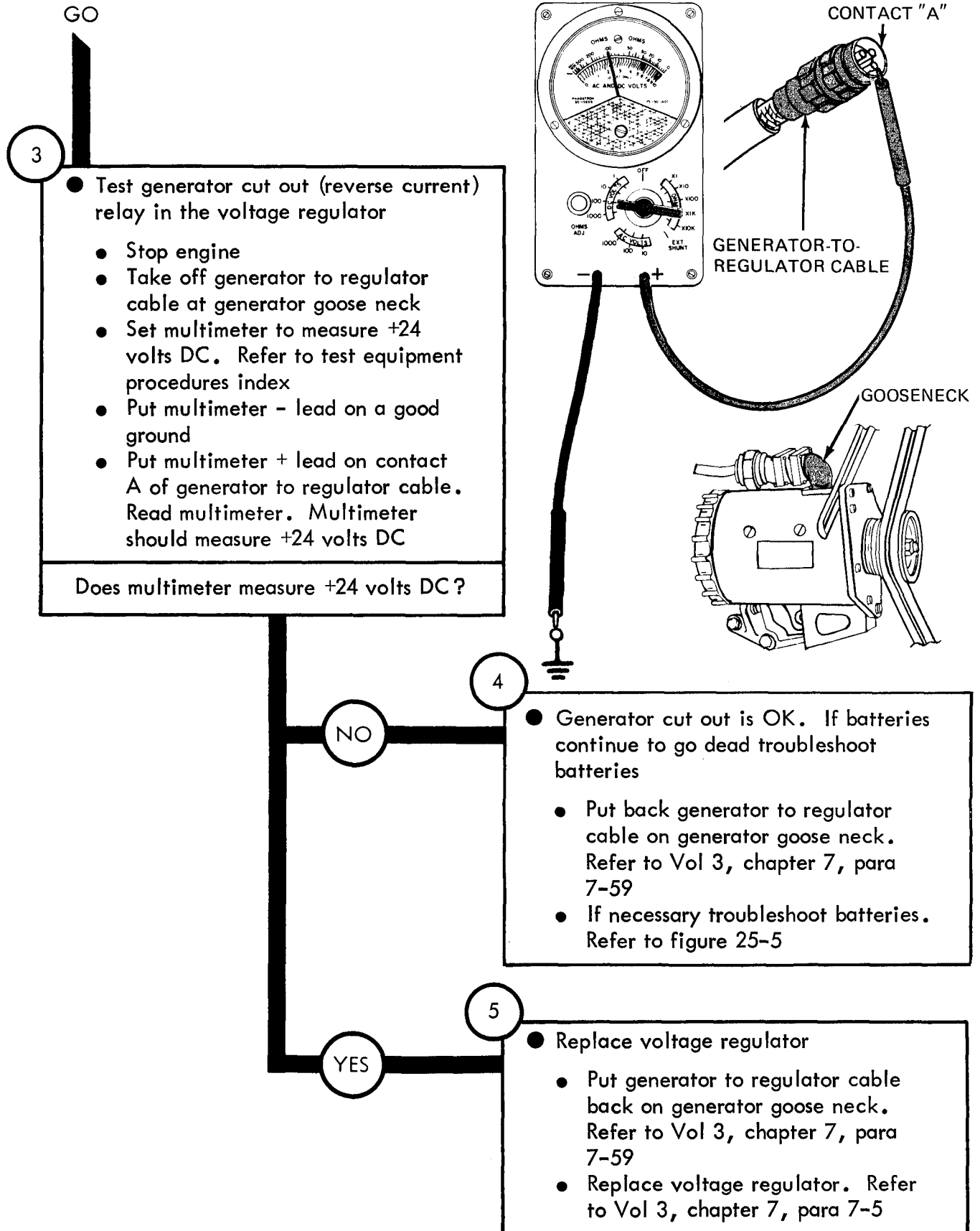

Figure 25-4 (Sheet 1 of 6)



TA 114262

Figure 25-4 (Sheet 2 of 6)

From step 2

6

- Check that current is not flowing through alternator field (rotor) to ground
 - Stop engine. Refer to TM 9-2320-209-10
 - Take off alternator field cable 1 plug from field cable 1 receptacle
 - Put multimeter - lead on a good ground
 - Put multimeter + lead in alternator field cable 1 receptacle. Read multimeter. Multimeter should measure +24 volts DC
- Does multimeter measure +24 volts DC?

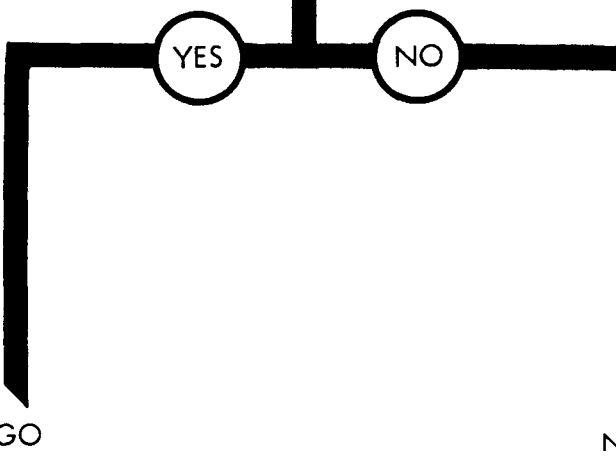
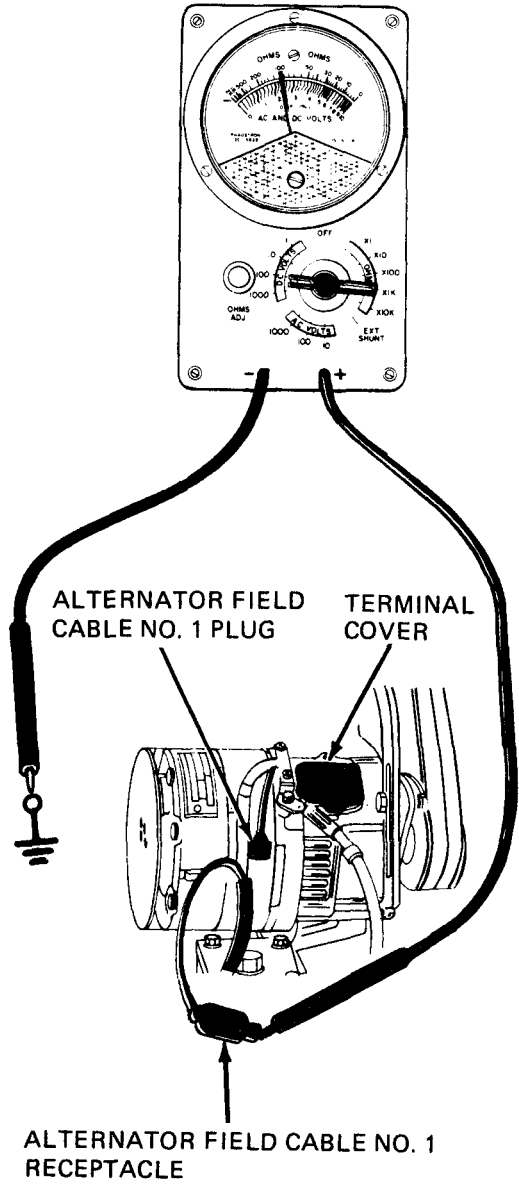

CAUTION

Failure to take off battery ground cable from battery - terminal will destroy the multimeter when doing the following test

Figure 25-4 (Sheet 3 of 6)

8

- Go to step 11

7

- Check alternator rectifier for integrity
 - Take off battery ground cable from battery - terminal. Refer to Vol 3, chapter 7, para 7-58
 - Take off terminal cover from alternator. Refer to Vol 3, chapter 7, para 7-4
 - Set multimeter to measure continuity. Refer to test equipment procedures index
 - Put multimeter - lead on a good ground
 - Put multimeter + lead on alternator output terminal. Read multimeter. Multimeter should measure 50 to 80 ohms

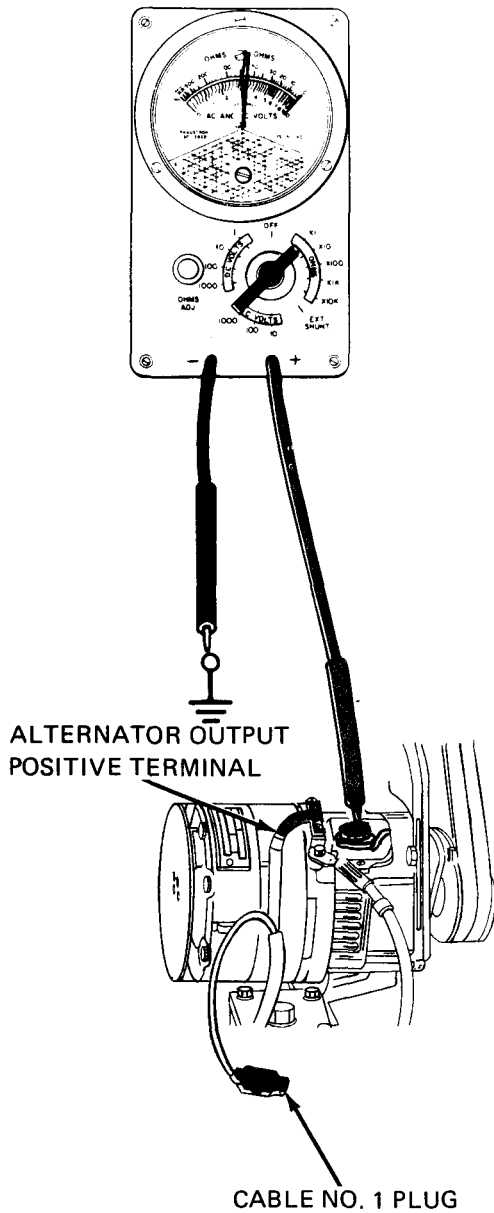

NO GO

Figure 25-4 (Sheet 4 of 6)

TA 114264

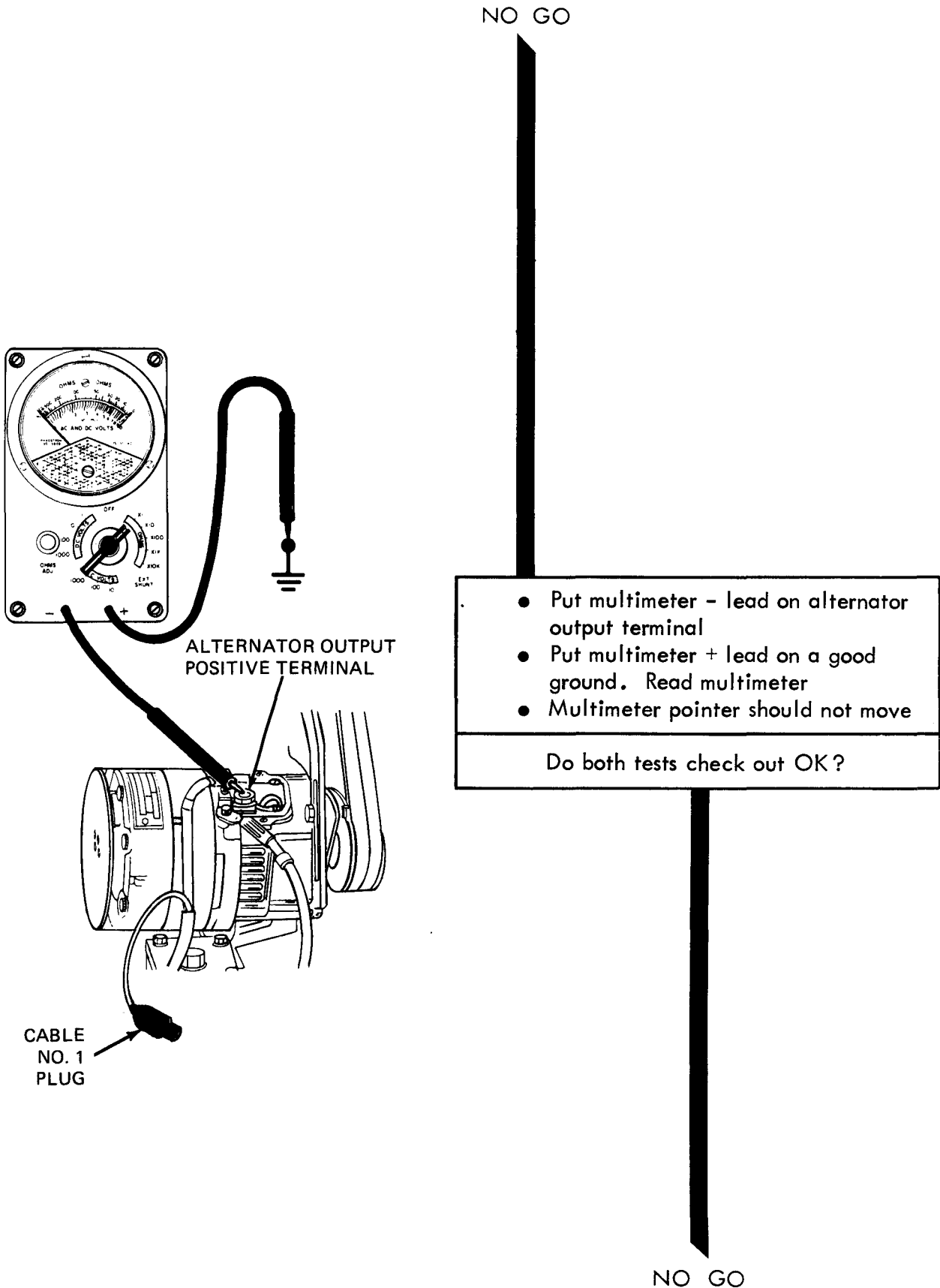

Figure 25-4 (Sheet 5 of 6)

TO 114055

From step 8

NO GO

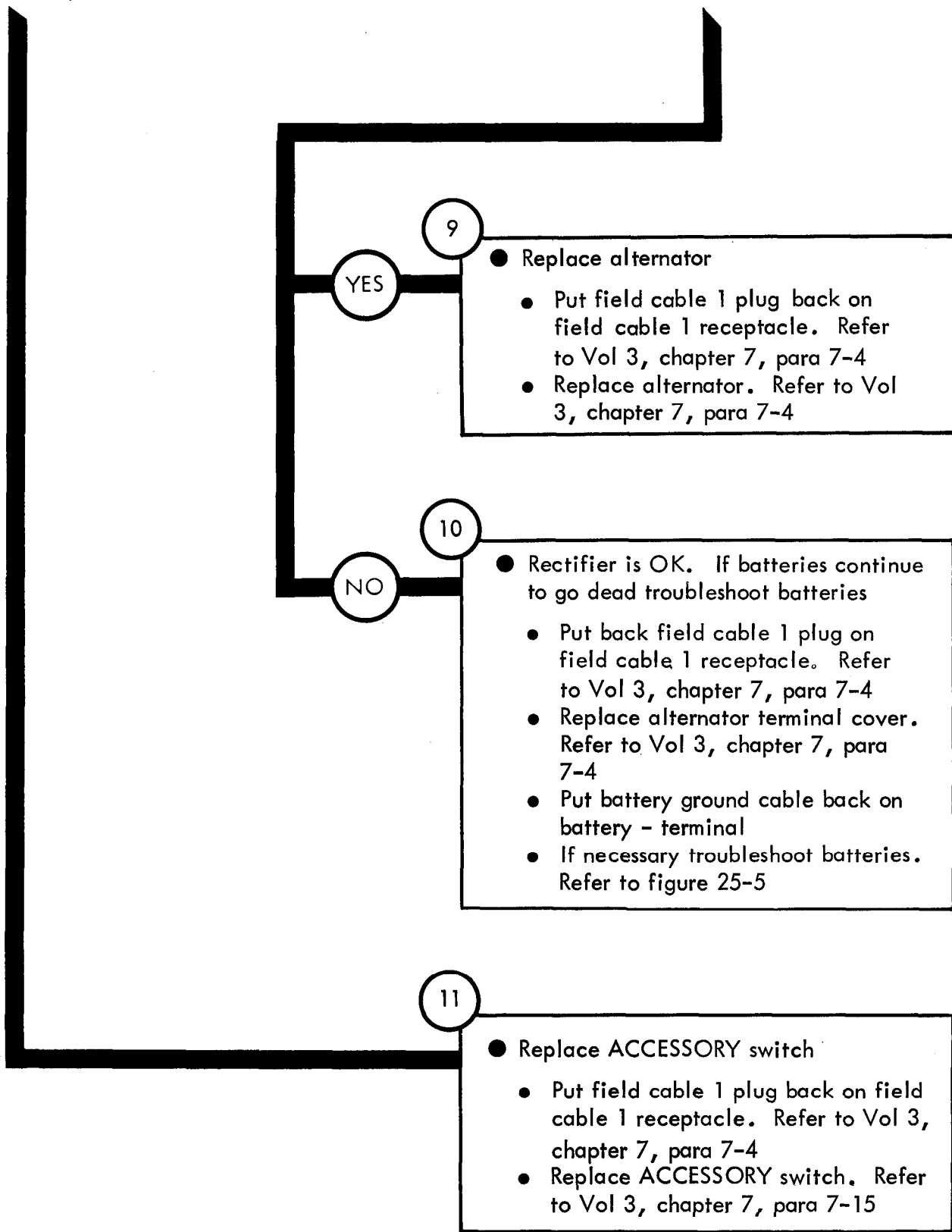

Figure 25-4 (Sheet 6 of 6)

Symptom

5

BATTERIES DO NOT FULLY CHARGE, OR DO NOT HOLD CHARGE

WARNING

Because of their higher power 24 volt systems are more dangerous than 6 or 12 volt systems

Do not let a "hot" wire touch metal parts of the truck at any time. "Flash" testing by striking a hot wire against a ground will cause an arc that can destroy the lead connector and possibly the lead itself

Accidental contact of metal tools between positive (+) battery or starter terminals will cause a direct short circuit which can cause burns on the hands, damaged tools, truck electrical components and batteries. The battery can explode spraying acid and sharp fragments that can cause serious or fatal injuries

1

- Park truck
- Refer to TM 9-2320-209-10

GO

Figure 25-5 (Sheet 1 of 7)

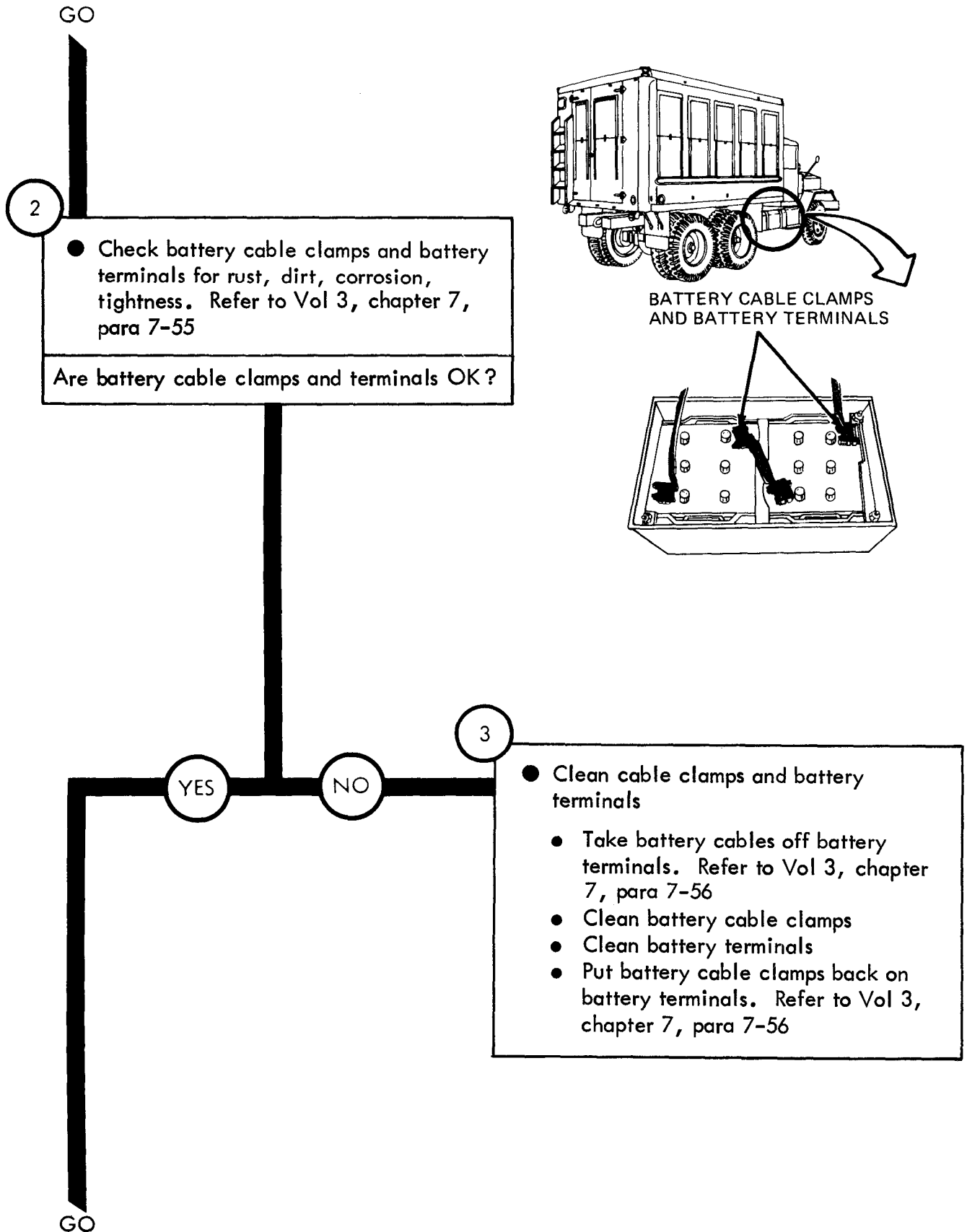

Figure 25-5 (Sheet 2 of 7)

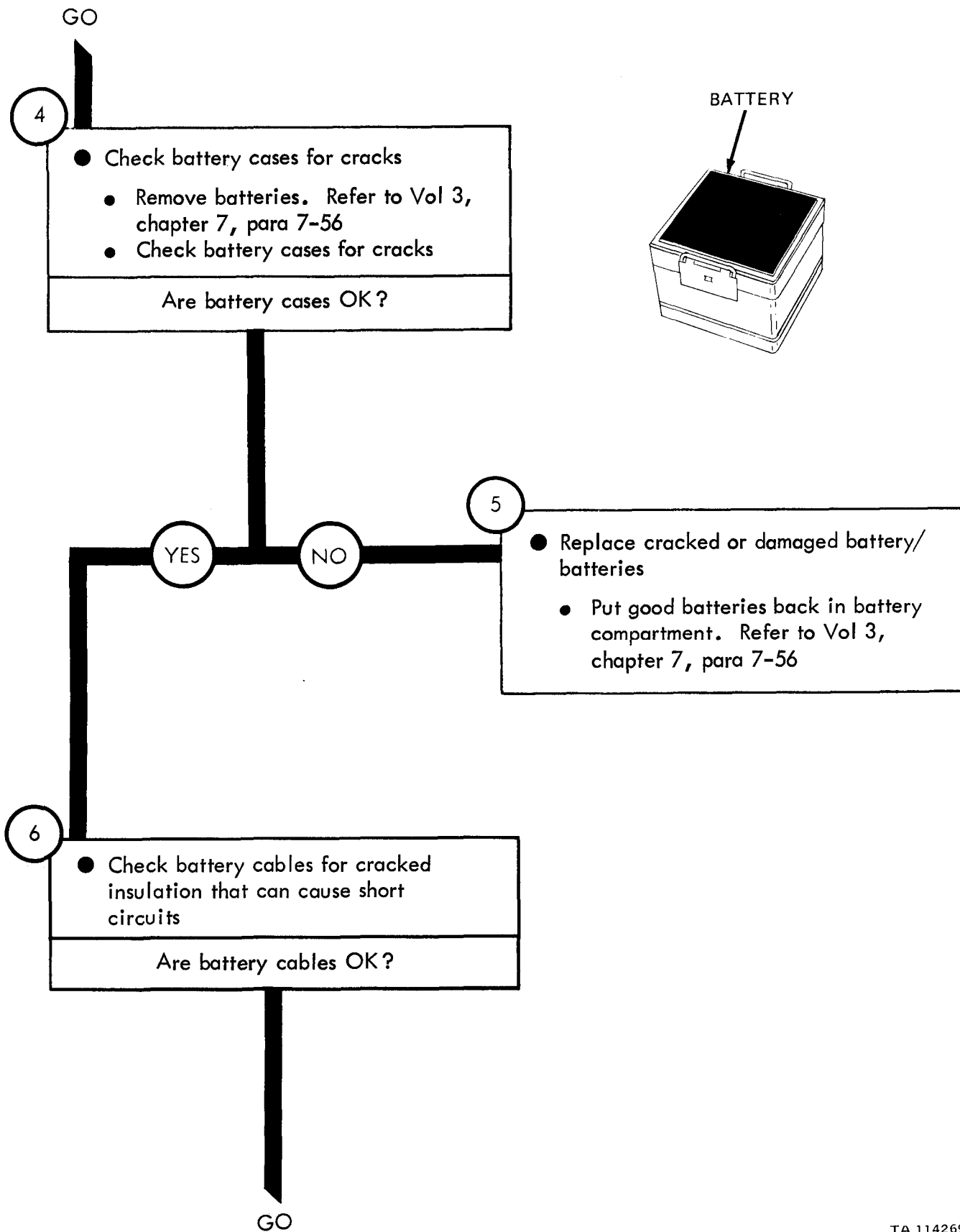

Figure 25-5 (Sheet 3 of 7)

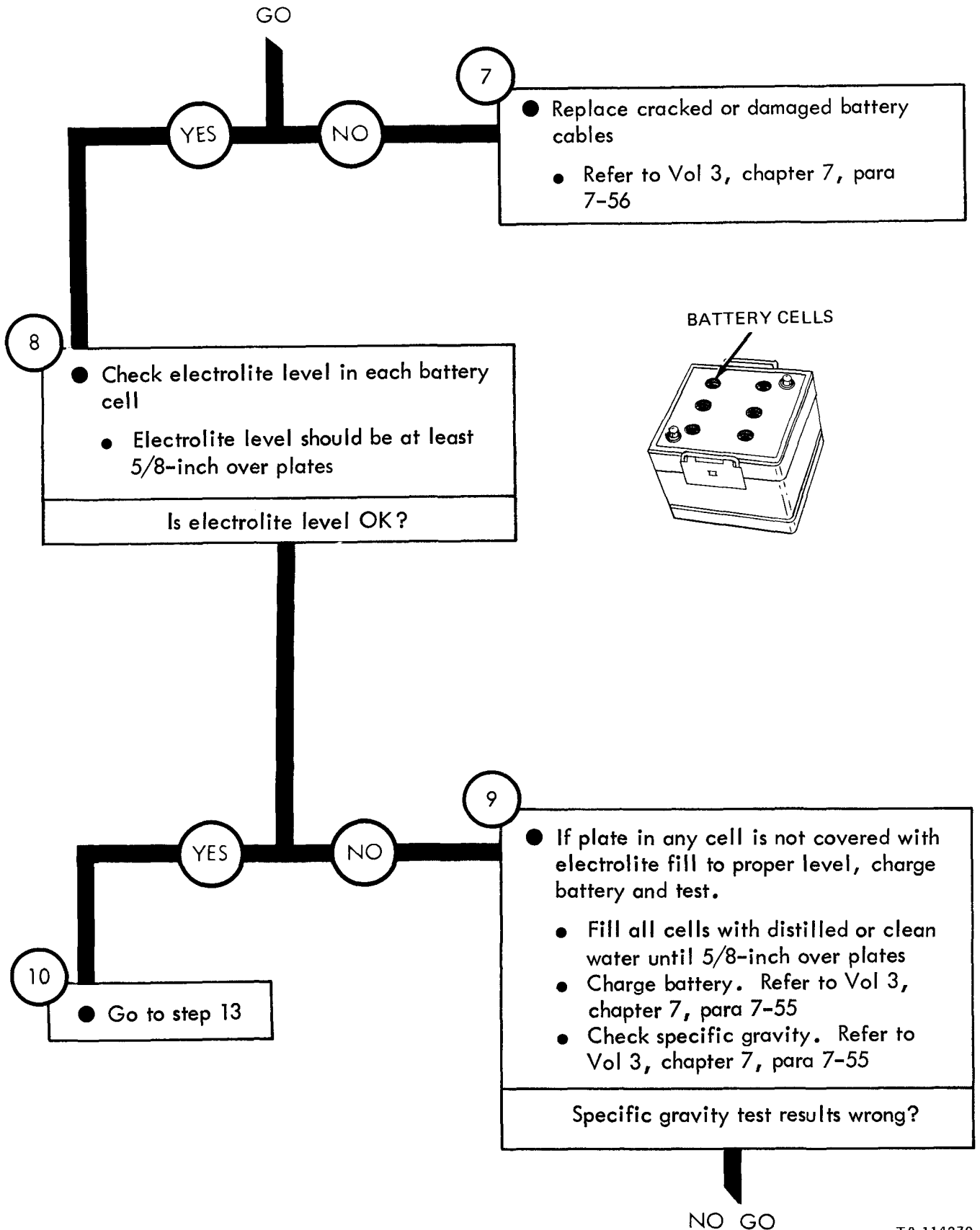

Figure 25-5 (Sheet 4 of 7)

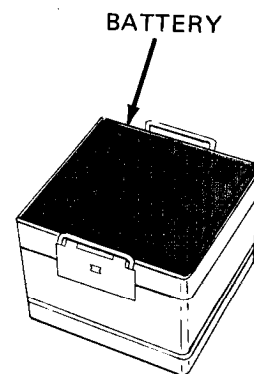
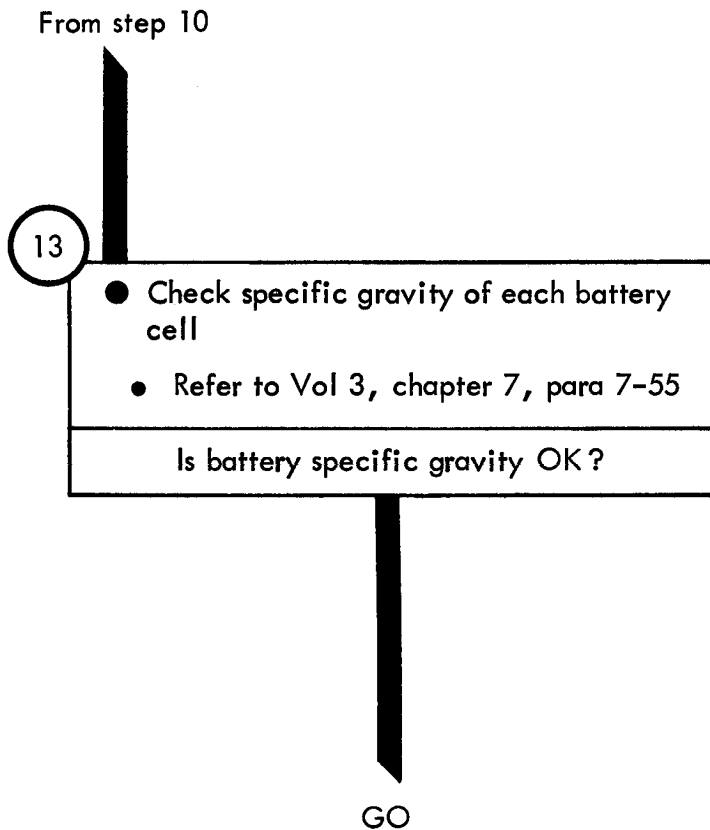
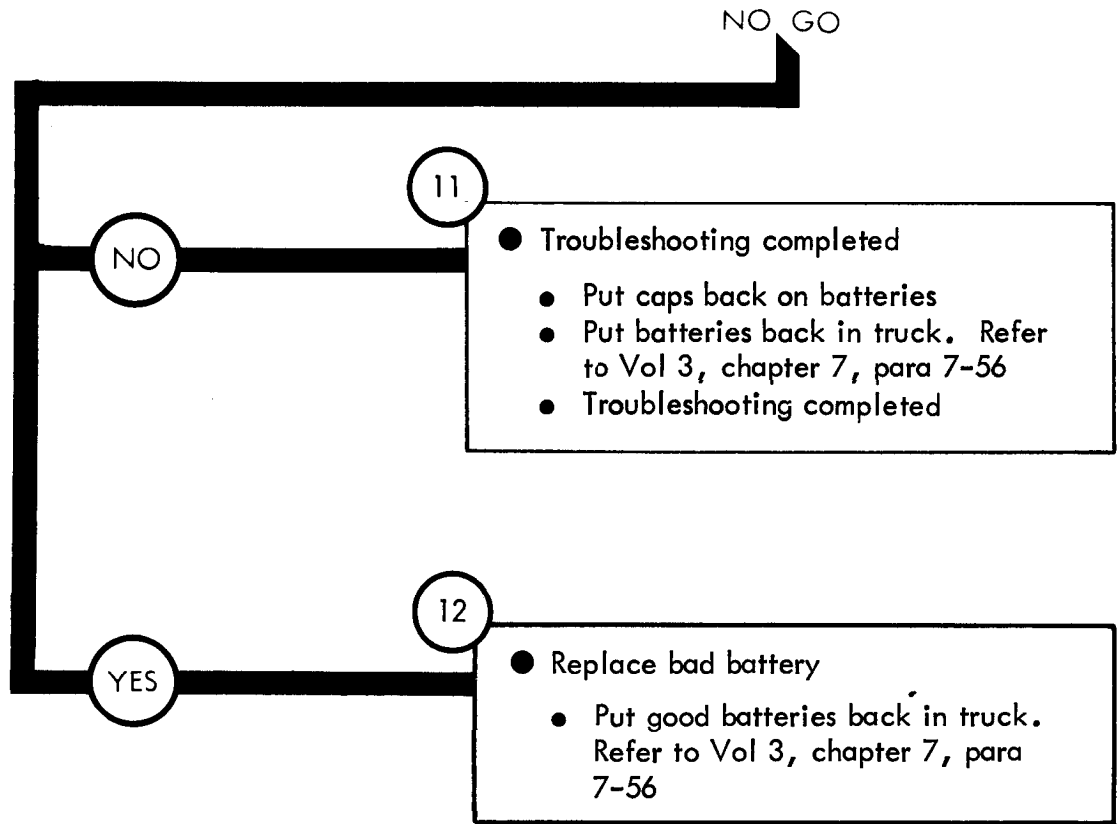

Figure 25-5 (Sheet 5 of 7)

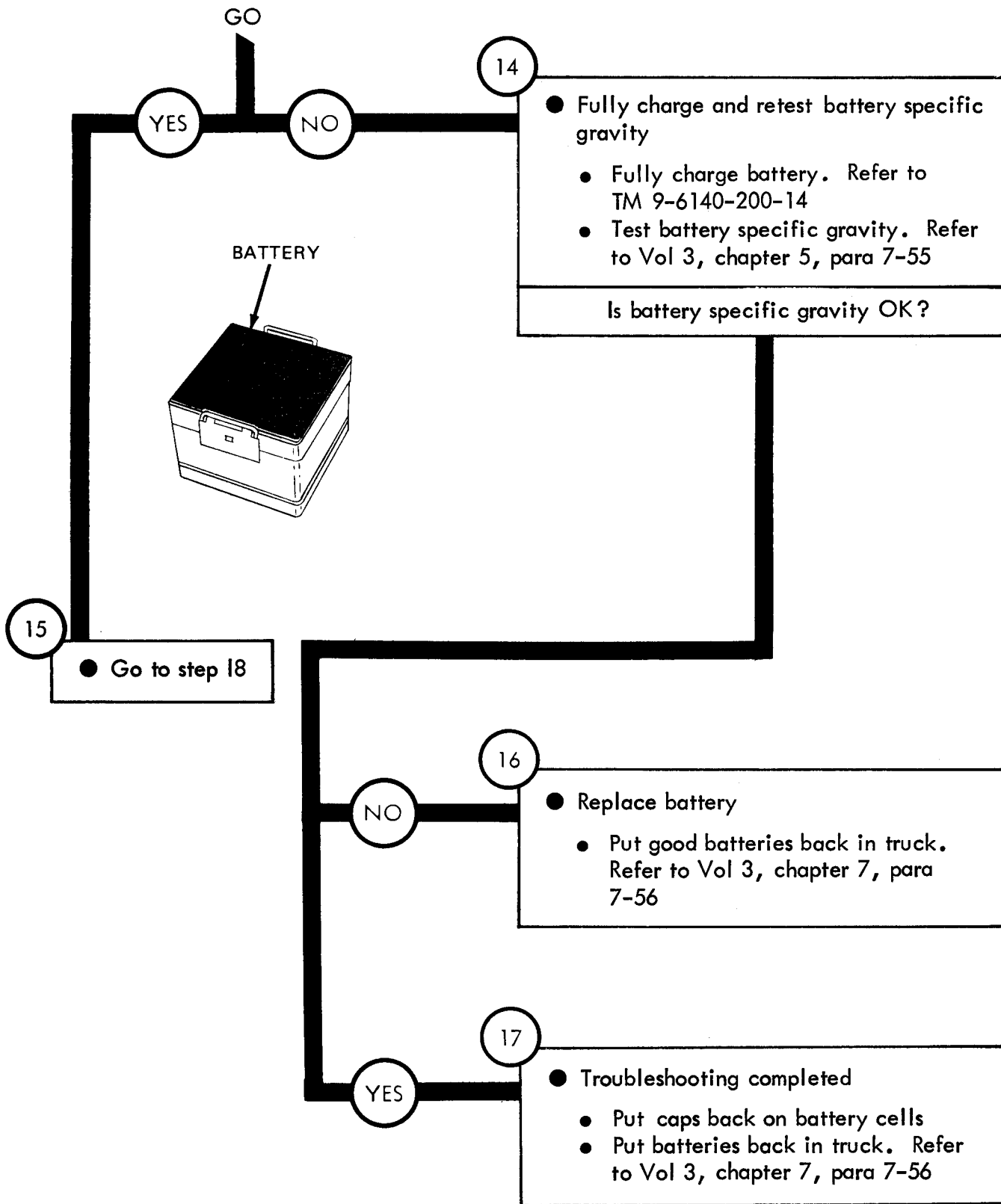

Figure 25-5 (Sheet 6 of 7)

From step 15

18

- Test voltage rise at batteries
 - Put batteries back in truck. Refer to Vol 3, chapter 7, para 7-56
 - Set ACCESSORY switch to ON
 - Start engine and run at 1000 to 1200 RPM. Refer to TM 9-2320-209-10

- Set multimeter to measure +28 volts DC. Refer to test equipment procedures index
- Put multimeter - lead to battery ground terminal
- Put multimeter + lead to battery + terminal
- Read multimeter. Multimeter should measure 28.5 volts DC

Does multimeter measure +28.5 volts DC?

YES

NO

19

- Check charging systems
 - Stop engine. Refer to TM 9-2320-209-10
 - If truck has generator refer to table 6-6 for generator troubleshooting symptoms
 - If truck has alternator refer to table 6-6 for alternator troubleshooting symptoms

20

- Check battery - generator indicator
 - Stop engine. Refer to TM 9-2320-209-10
 - Check battery - generator indicator. Refer to table 6-6 for instruments and gages troubleshooting symptoms

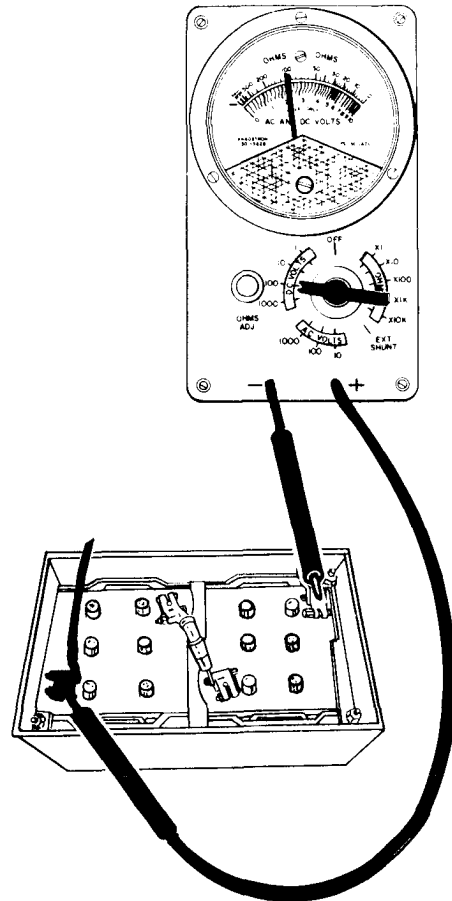

Figure 25-5 (Sheet 7 of 7)

Symptom

6 ONE HEADLIGHT DOES NOT LIGHT, OTHER HEADLIGHT LIGHTS

NOTE
When checking voltage +24 volts DC means a range of +23 volts DC to +26 volts DC

- 1
- Park truck
 - Refer to TM 9-2320-209-10

- 2
- Check for +24 volts DC at low beam input of bad headlight
 - Take off leads 17 (high beam), 18 (low beam), and 91 (ground) from headlight housing
 - Set **multimeter** to measure +24 volts DC. Refer to test equipment procedures index
 - Set light switch main lever to SERVICE DRIVE
 - Put **multimeter** - lead on lead 91 contact and **multimeter** + lead on lead 18 contact. Read **multimeter**. **Multimeter** should read +24 volts DC. If not, push dimmer switch and read meter again
- Did **multimeter** measure +24 volts DC?

GO

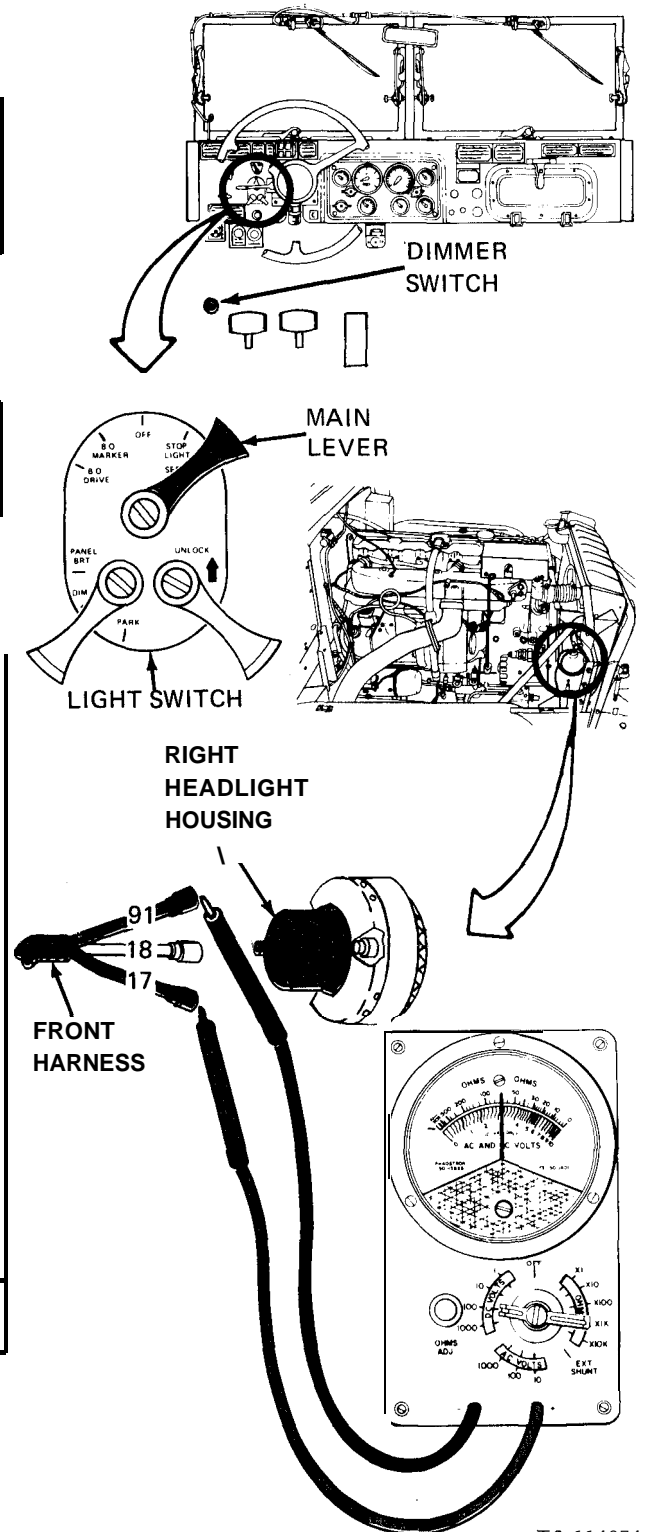

TA 114274

Figure 25-6 (Sheet 1 of 4)

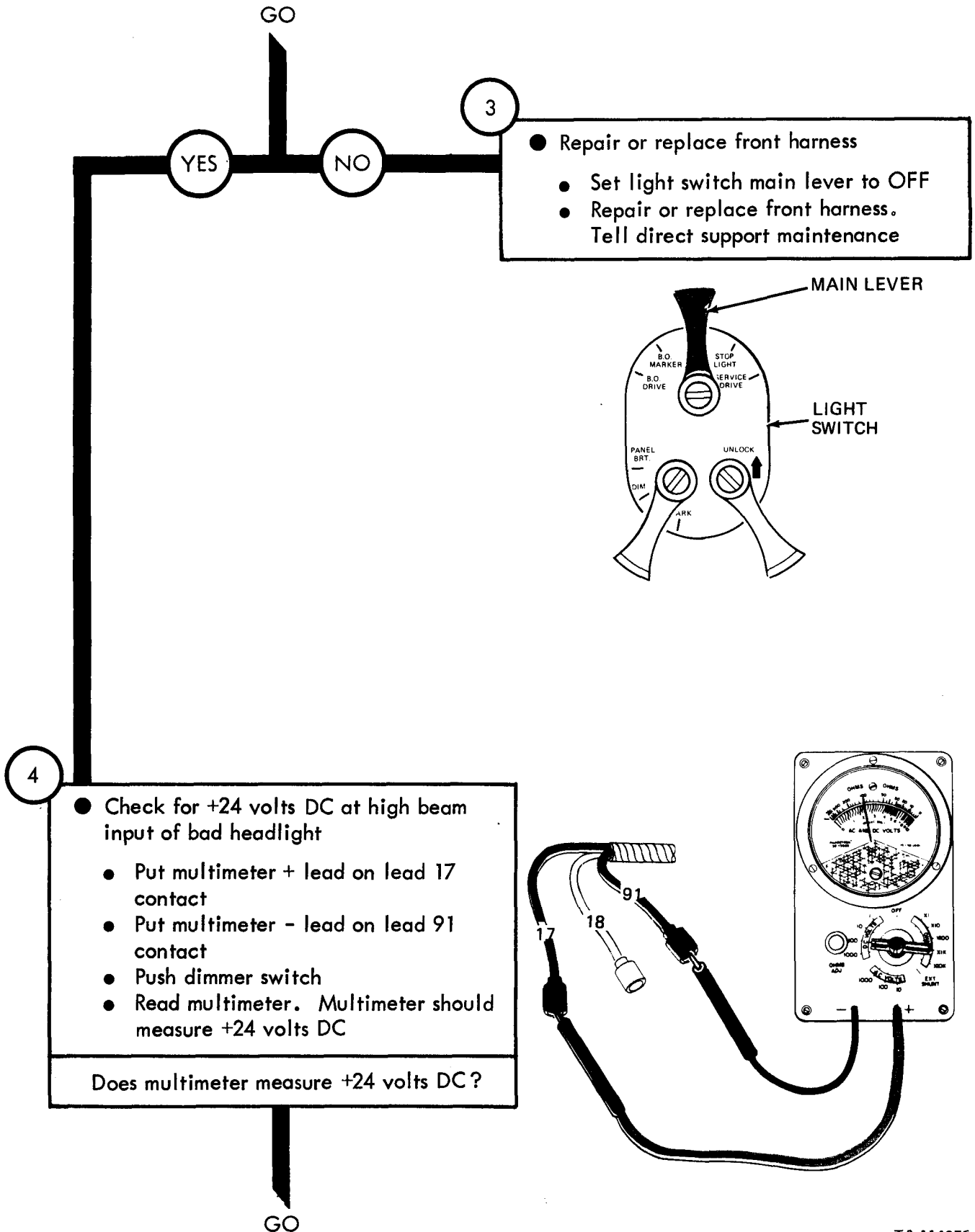

Figure 25-6 (Sheet 2 of 4)

TA 114275

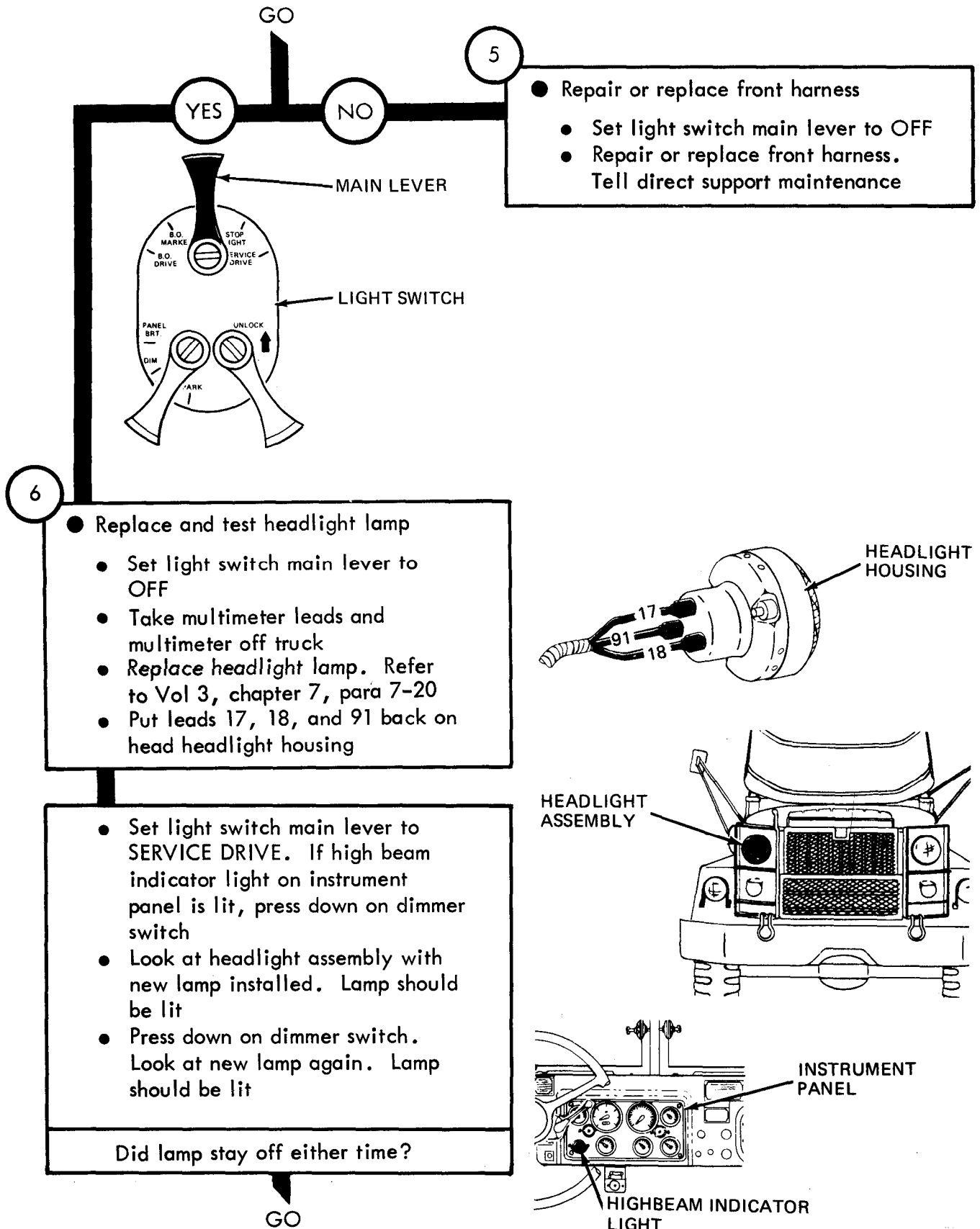

Figure 25-6 (Sheet 3 of 4)

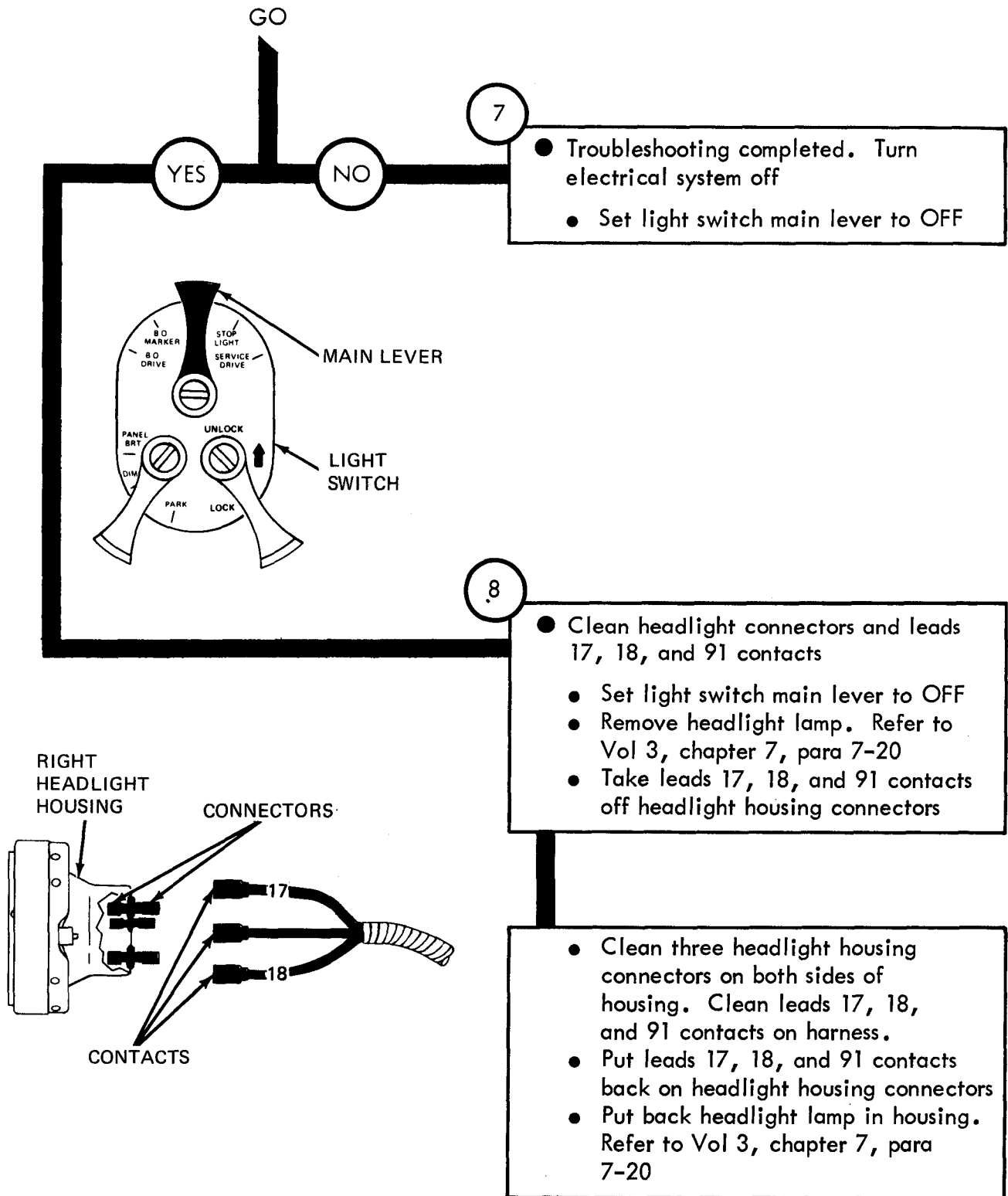

Figure 25-6 (Sheet 4 of 4)

Symptom

7

BOTH HEADLIGHTS DO NOT LIGHT, OTHER TRUCK RUNNING LIGHTS LIGHT

NOTE

When checking voltage, +24 volts DC means a range of +23 volts DC to +26 volts DC

1

- Park truck
- Refer to TM 9-2320-209-10

2

- Check for +24 volts DC at right headlight low beam input
 - Take off leads 17 (high beam), 18 (low beam) and 91 (ground) from right headlight housing
 - Set multimeter to measure +24 volts DC. Refer to test equipment procedures index
 - Set light switch main lever to SERVICE DRIVE
 - Put multimeter - lead on lead 91 contact and multimeter + lead on lead 18 contact
 - Read multimeter. Multimeter should read +24 volts DC. If not, push dimmer switch and read multimeter again

Does multimeter measure +24 volts DC?

GO

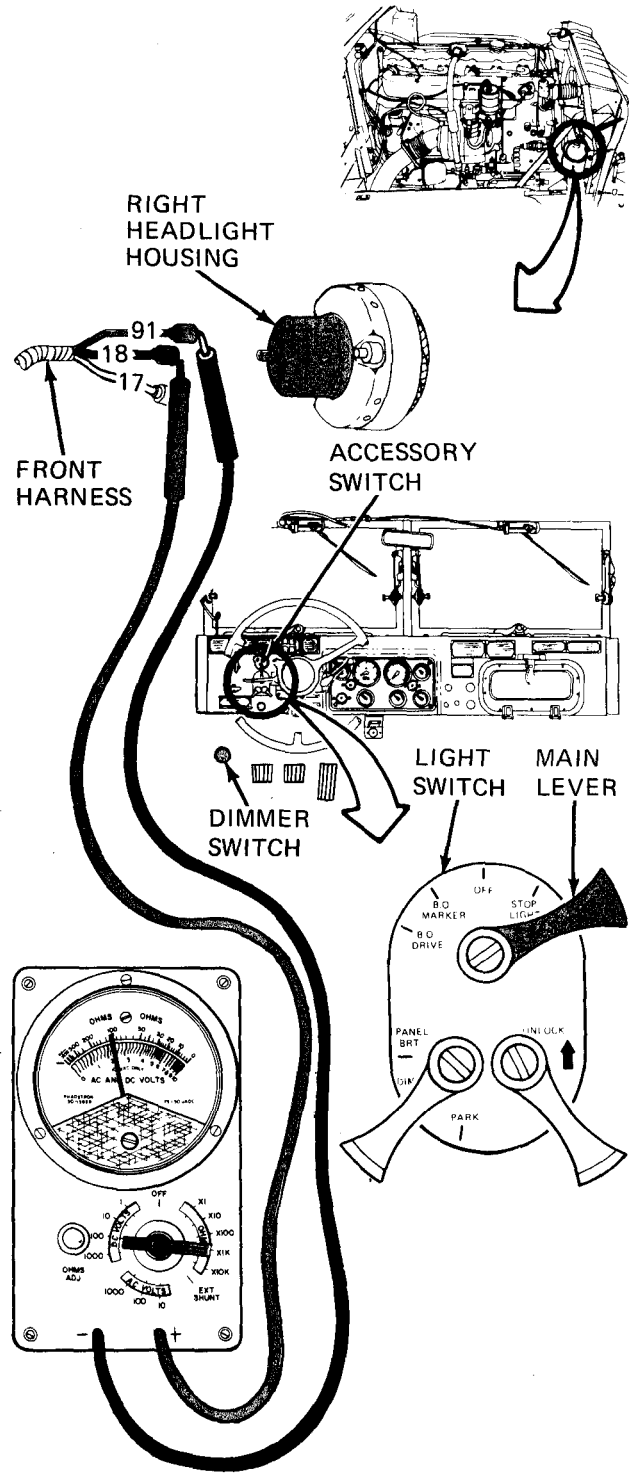

TA 114278

Figure 25-7 (Sheet 1 of 11)

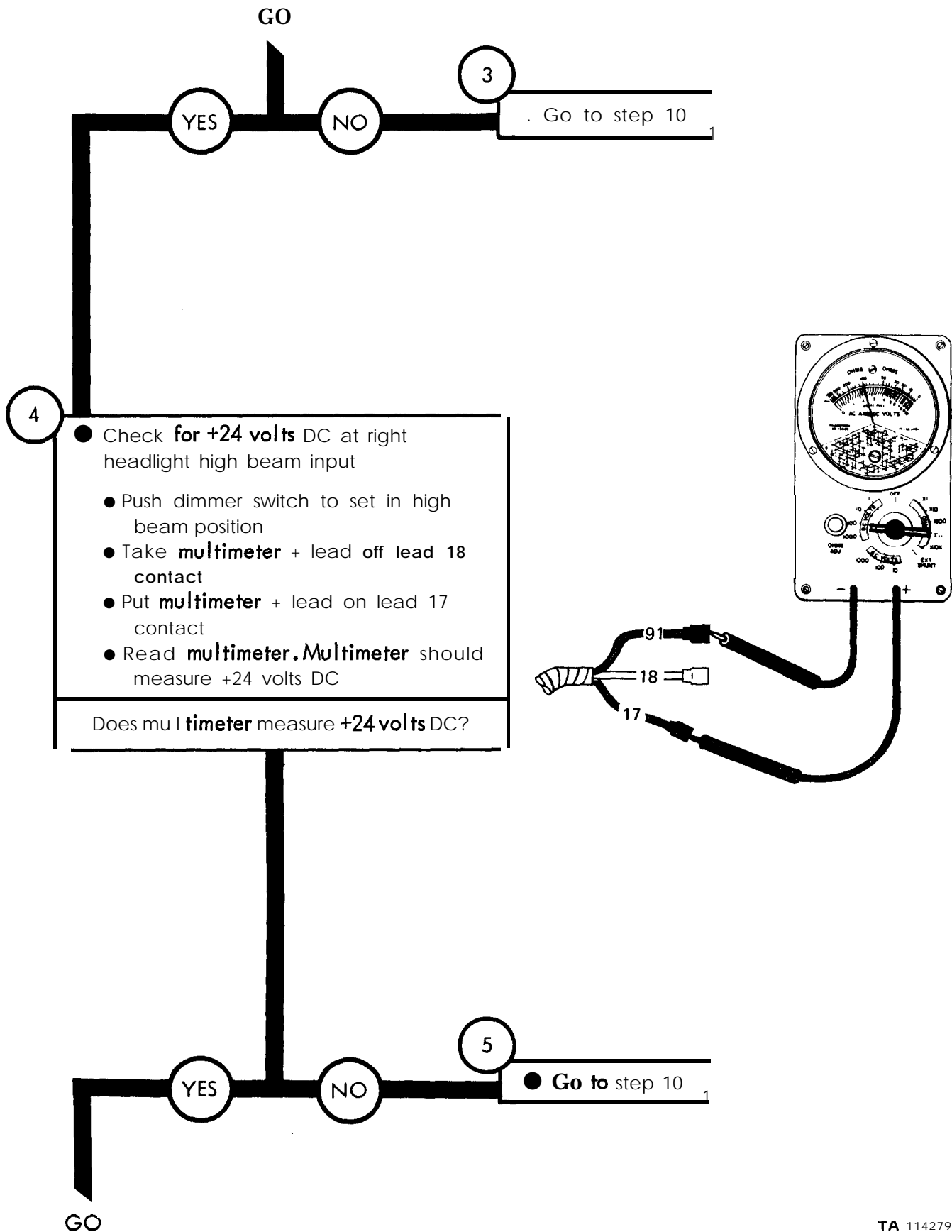

Figure 25-7 (Sheet 2 of 11)

GO

6

- Check for +24 volts DC at left head light low beam input
 - Take off leads 17 (high beam), 18 (low beam), and 91 (ground) from left headlight housing
 - Put **multimeter** - lead on lead 91 contact and **multimeter** + lead on lead 18 contact
 - Read **multimeter**. **Multimeter** should read +24 volts DC. If **not**, push dimmer switch and read **multimeter** again

Does **mu ltimeter** read +24 volts DC?

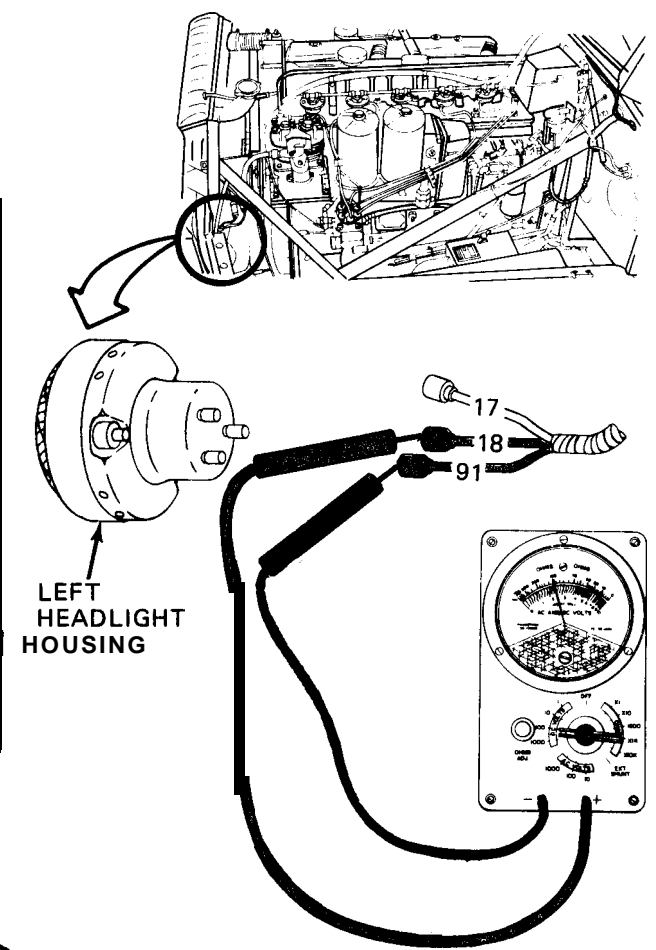

YES NO

7

- Go to step 10

8

- Check for +24 volts DC at left headlight high beam input
 - Push dimmer switch to set in high beam position
 - Take **multimeter** + lead off lead 18 contact
 - Put **multimeter** + lead on lead 17 contact
 - Read **multimeter**. **Multimeter** should measure +24 volts DC.

Does **multimeter** measure less than +24 volts DC?

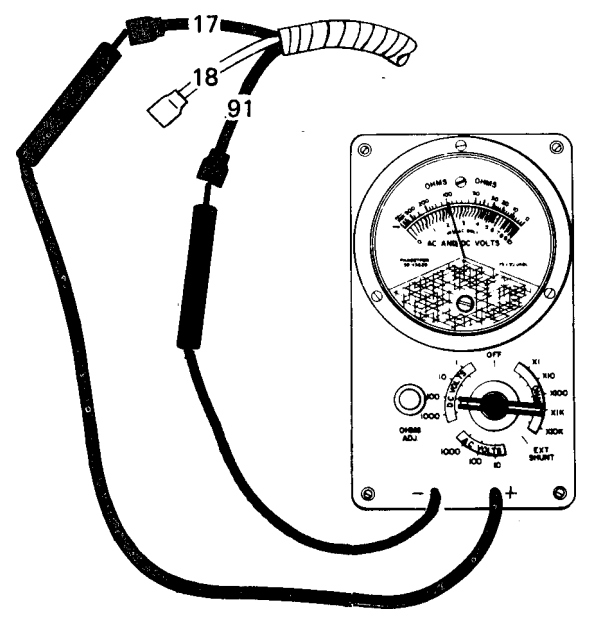

GO

Figure 25-7 (Sheet 3 of 11)

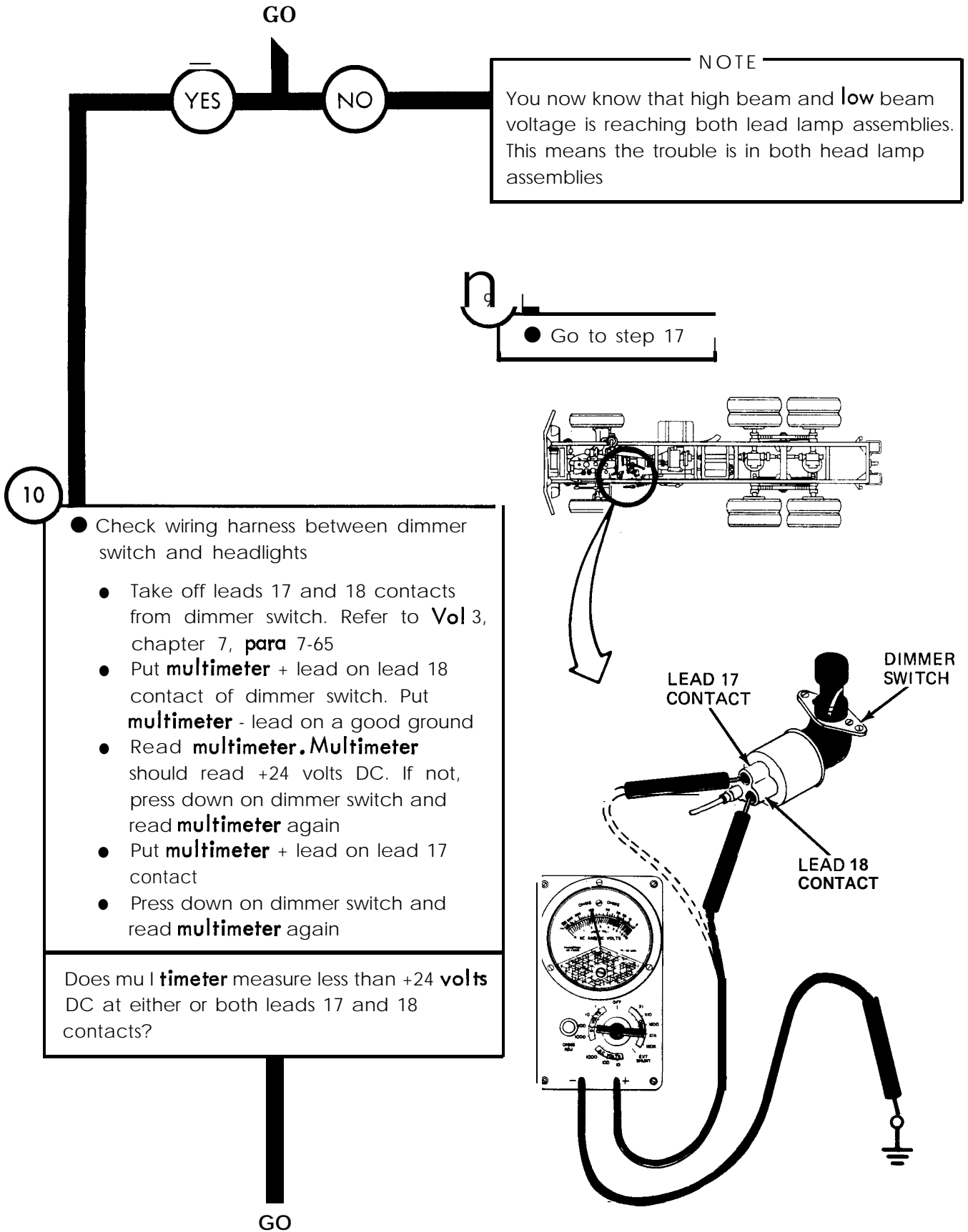

NOTE
 You now know that high beam and low beam voltage is reaching both lead lamp assemblies. This means the trouble is in both head lamp assemblies

9
 ● Go to step 17

- 10
- Check wiring harness between dimmer switch and headlights
 - Take off leads 17 and 18 contacts from dimmer switch. Refer to Vol 3, chapter 7, para 7-65
 - Put **multimeter** + lead on lead 18 contact of dimmer switch. Put **multimeter** - lead on a good ground
 - Read **multimeter**. **Multimeter** should read +24 volts DC. If not, press down on dimmer switch and read **multimeter** again
 - Put **multimeter** + lead on lead 17 contact
 - Press down on dimmer switch and read **multimeter** again

Does multimeter measure less than +24 volts DC at either or both leads 17 and 18 contacts?

GO

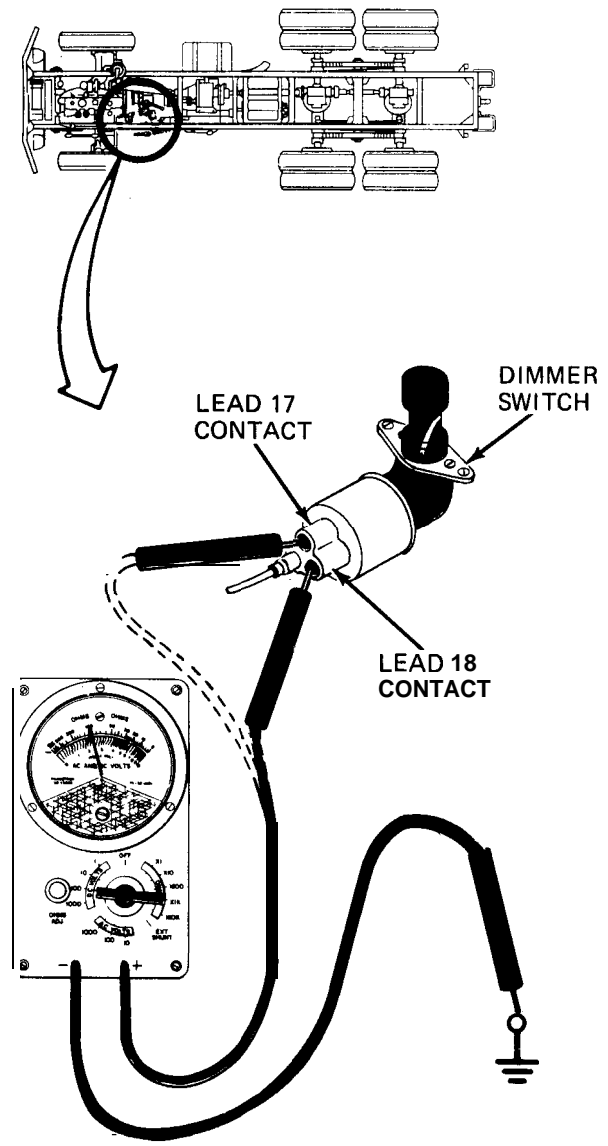

TA 114281

Figure 25-7 (Sheet 4 of 11)

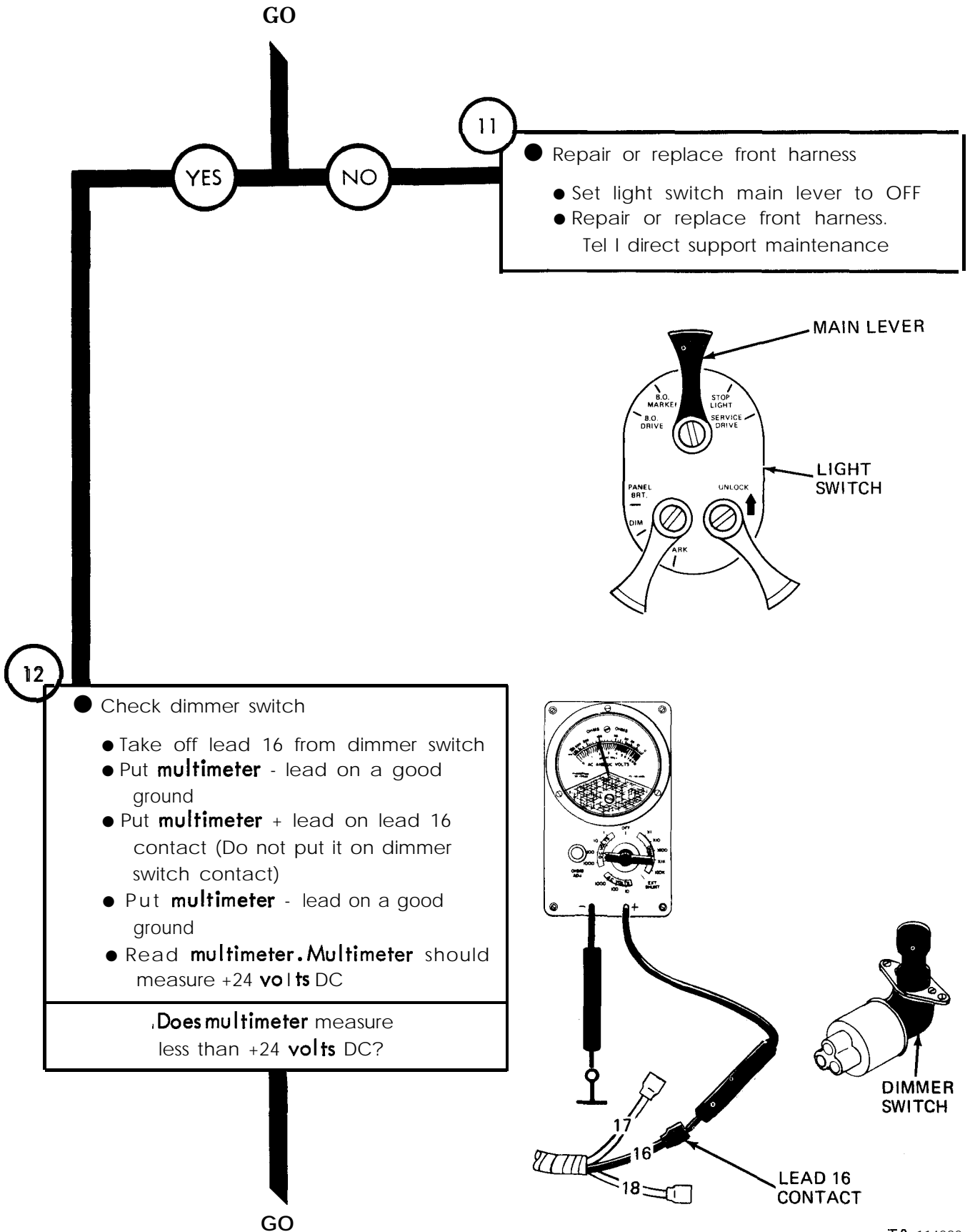

11

- Repair or replace front harness
- Set light switch main lever to OFF
- Repair or replace front harness. Tel I direct support maintenance

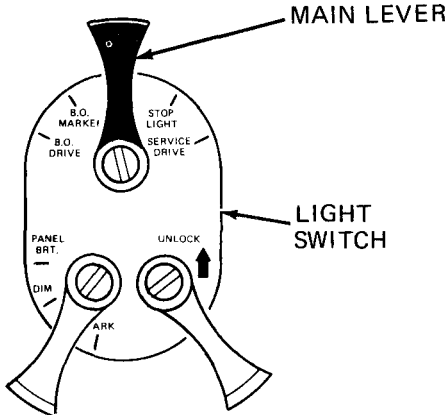

12

- Check dimmer switch
- Take off lead 16 from dimmer switch
- Put **multimeter** - lead on a good ground
- Put **multimeter** + lead on lead 16 contact (Do not put it on dimmer switch contact)
- Put **multimeter** - lead on a good ground
- Read **multimeter**. **Multimeter** should measure +24 **volts** DC

Does multimeter measure less than +24 **volts** DC?

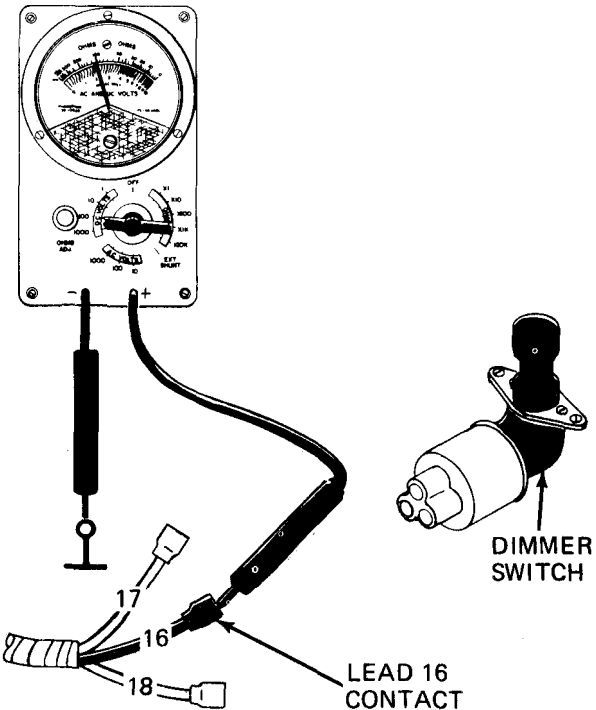

Figure 25-7 (Sheet 5 of 11)

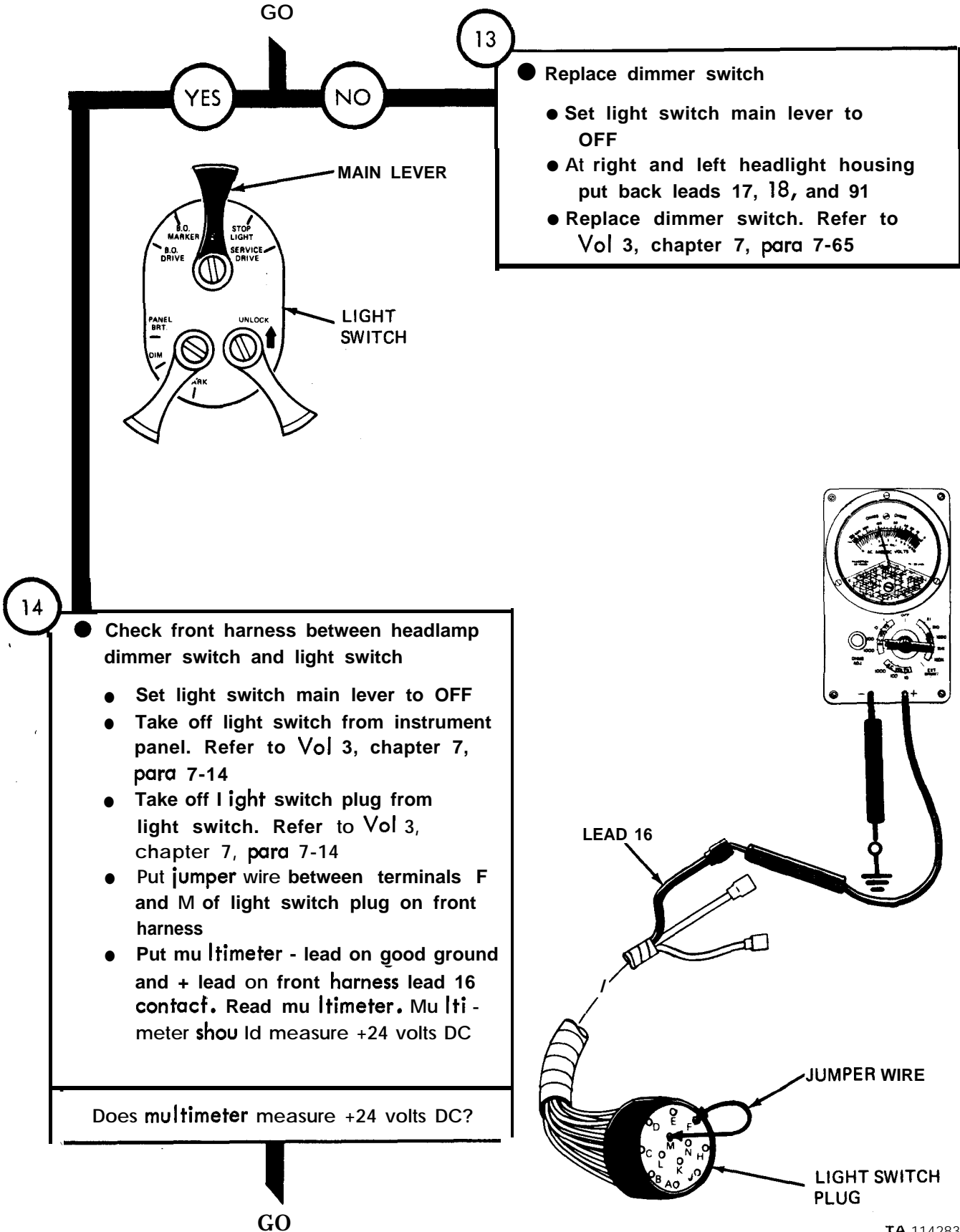

Figure 25-7 (Sheet 6 of 11)

TA 114283

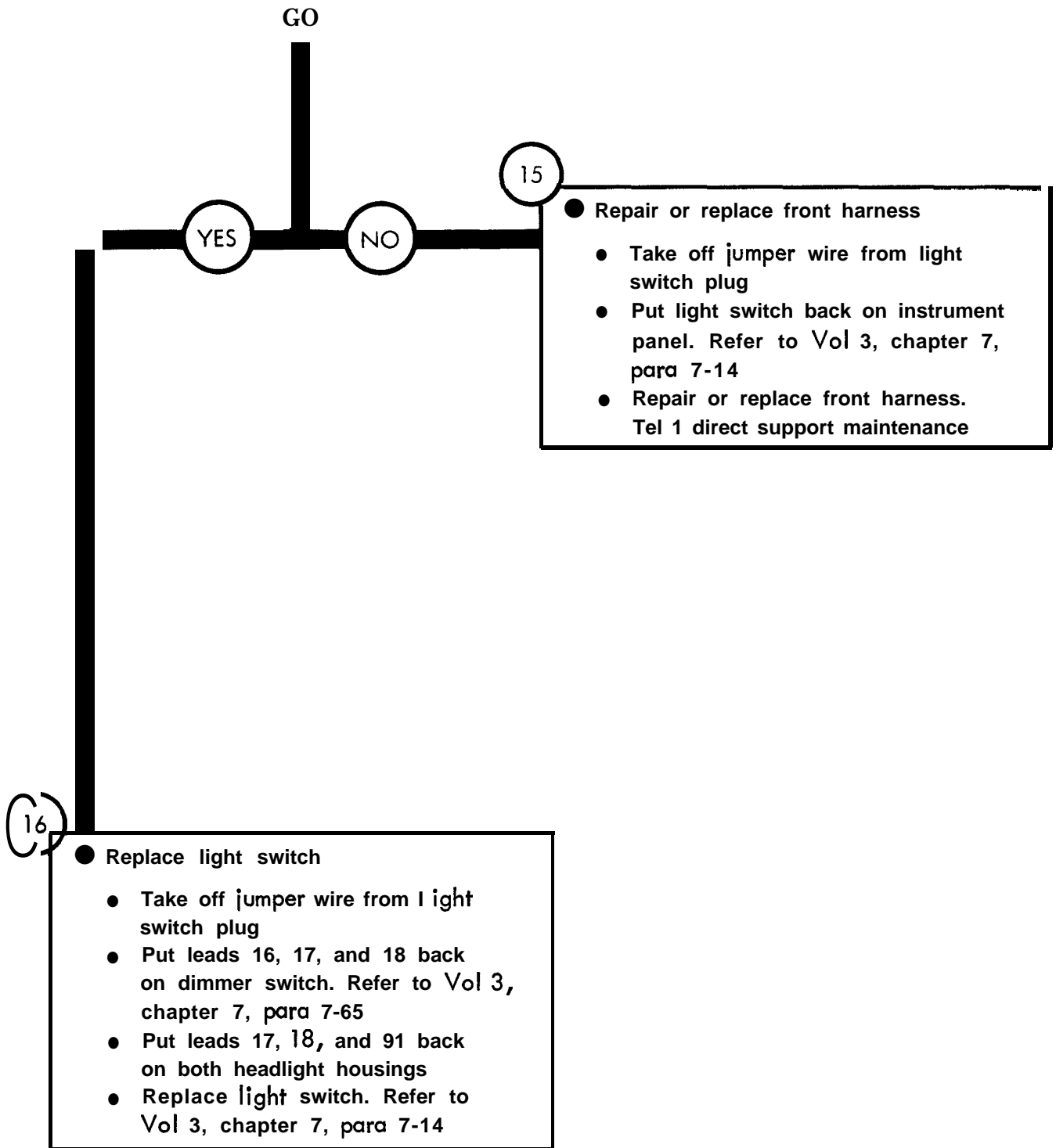

Figure 25-7 (Sheet 7 of 11)

From step 9

17

- Replace and test right headlight assembly lamp
- Set light switch main lever to OFF
 - Replace right headlight assembly lamp. Refer to **Vol 3**, chapter 7, **para 7-17**
 - Put leads 17, 18, and 91 back on right headlight housing

- Set light switch main lever to SERVICE DRIVE. [f high beam indicator light on instrument panel is lit, press down on dimmer switch
- Look at right headlight lamp. Lamp should be lit
- Press down on dimmer switch
- **Look at right headlight lamp. Lamp should be lit**

Was lamp lit both times?

GO

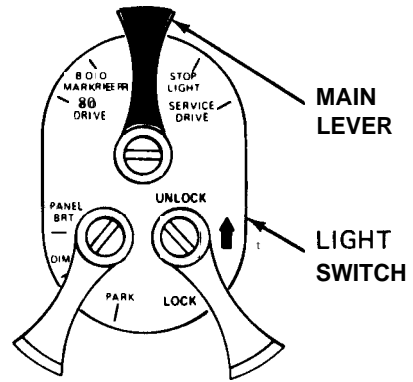

RIGHT HEADLIGHT HOUSING

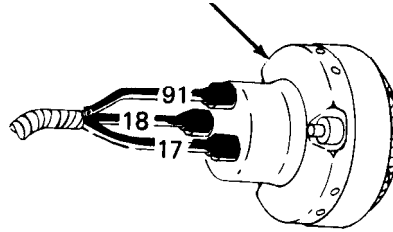

RIGHT HEADLIGHT HOUSING

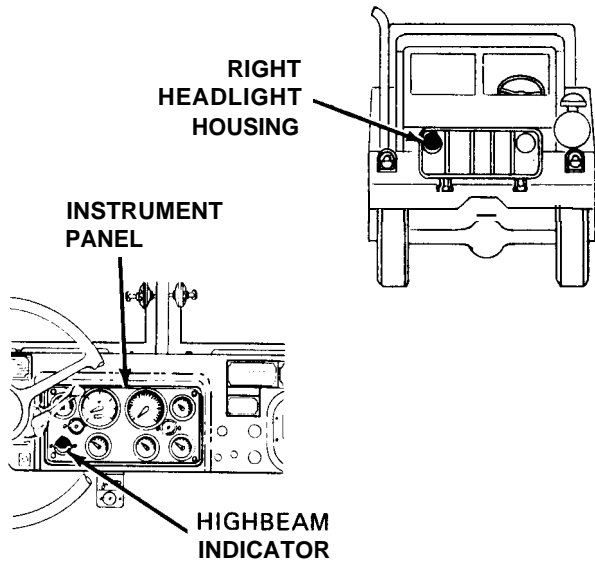

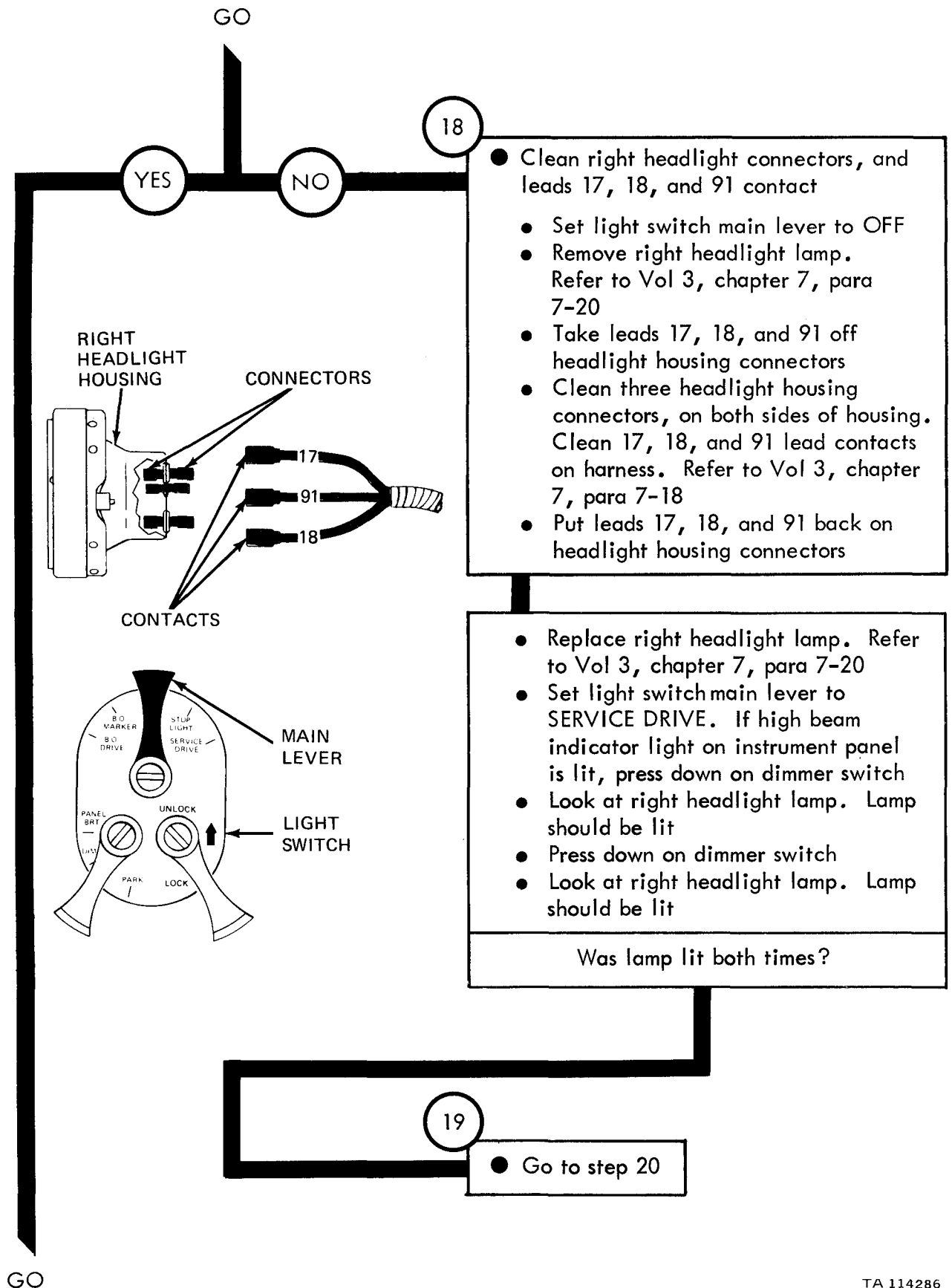

- Clean right headlight connectors, and leads 17, 18, and 91 contact
- Set light switch main lever to OFF
- Remove right headlight lamp. Refer to Vol 3, chapter 7, para 7-20
- Take leads 17, 18, and 91 off headlight housing connectors
- Clean three headlight housing connectors, on both sides of housing. Clean 17, 18, and 91 lead contacts on harness. Refer to Vol 3, chapter 7, para 7-18
- Put leads 17, 18, and 91 back on headlight housing connectors

- Replace right headlight lamp. Refer to Vol 3, chapter 7, para 7-20
- Set light switch main lever to SERVICE DRIVE. If high beam indicator light on instrument panel is lit, press down on dimmer switch
- Look at right headlight lamp. Lamp should be lit
- Press down on dimmer switch
- Look at right headlight lamp. Lamp should be lit

Was lamp lit both times?

19

- Go to step 20

Figure 25-7 (Sheet 9 of 11)

GO

20

- Replace and test left headlight lamp
 - Set light switch main lever to OFF
 - Replace left head light lamp. Refer to Vol 3, chapter 7, para 7-20
 - Put leads 17, 18, and 91 contacts back on left headlight housing
 - Set light switch main lever to service drive. If high beam indicator light on instrument panel is lit, press down on dimmer switch

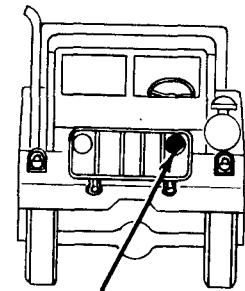
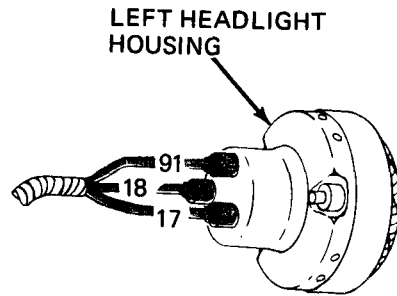

- Look at left headlight housing. Lamp should be lit
- Press down on dimmer switch
- Look at left headlamp housing. Lamp should be lit

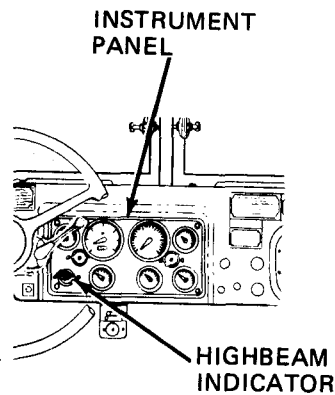

LEFT HEADLAMP HOUSING

Did lamp stay off either time?

GO

Figure 25-7 (Sheet 10 of 11)

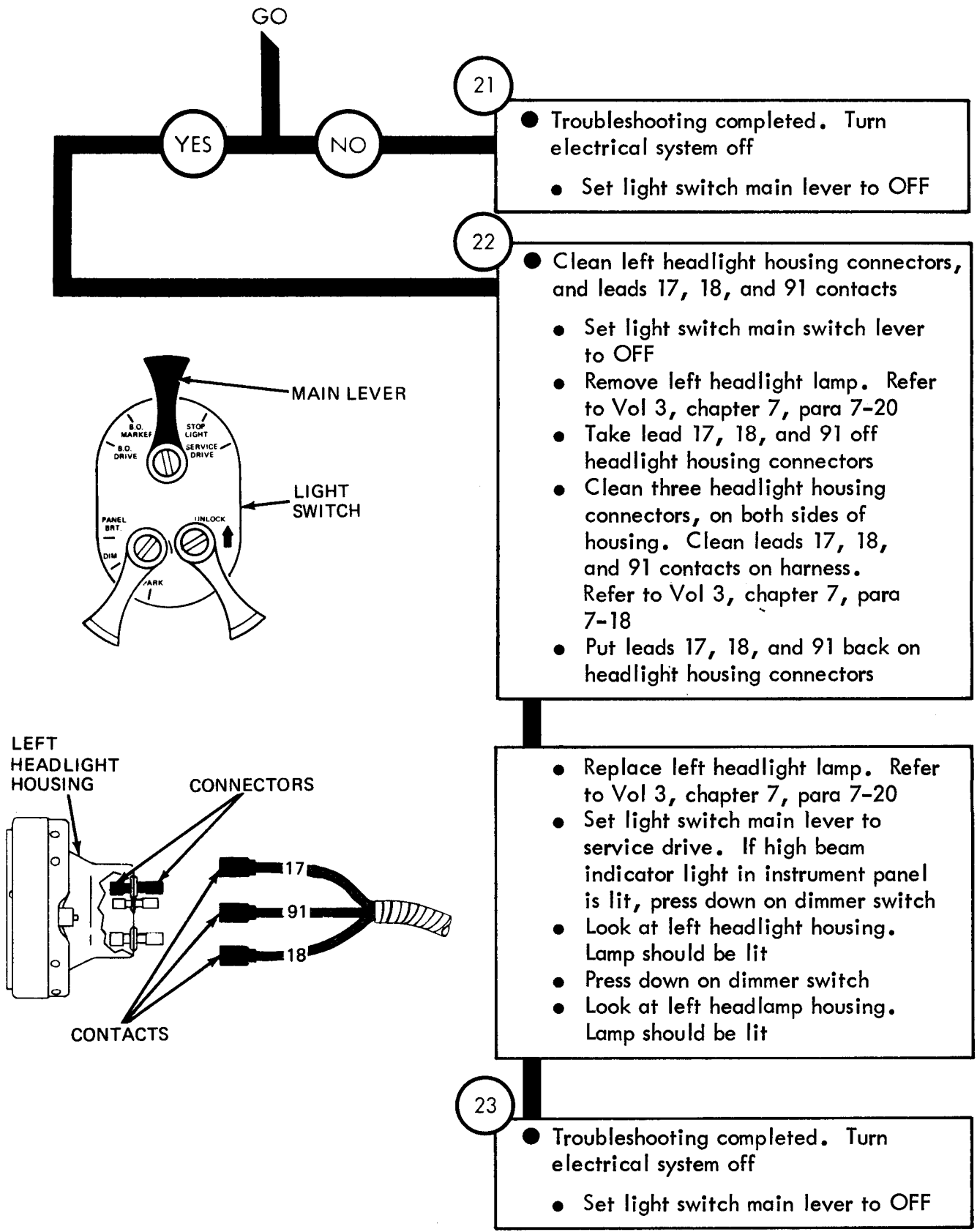

21

- Troubleshooting completed. Turn electrical system off
- Set light switch main lever to OFF

22

- Clean left headlight housing connectors, and leads 17, 18, and 91 contacts
- Set light switch main switch lever to OFF
- Remove left headlight lamp. Refer to Vol 3, chapter 7, para 7-20
- Take lead 17, 18, and 91 off headlight housing connectors
- Clean three headlight housing connectors, on both sides of housing. Clean leads 17, 18, and 91 contacts on harness. Refer to Vol 3, chapter 7, para 7-18
- Put leads 17, 18, and 91 back on headlight housing connectors

- Replace left headlight lamp. Refer to Vol 3, chapter 7, para 7-20
- Set light switch main lever to service drive. If high beam indicator light in instrument panel is lit, press down on dimmer switch
- Look at left headlight housing. Lamp should be lit
- Press down on dimmer switch
- Look at left headlamp housing. Lamp should be lit

23

- Troubleshooting completed. Turn electrical system off
- Set light switch main lever to OFF

Figure 25-7 (Sheet 11 of 11)

Symptom

8

BLACKOUT HEADLIGHT DOES NOT LIGHT, OTHER TRUCK
RUNNING LIGHTS LIGHT

NOTE

When measuring voltage +24 volts means
a range of +23 to +26 volts DC

1

- Park truck
- Refer to TM 9-2320-209-10

GO

Figure 25-8 (Sheet 1 of 6)

GO

2

- Check for +24 volts DC at blackout headlight assembly
- Take off lead 19 at rear of blackout headlight housing
- Set multimeter to measure +24 volts DC. Refer to test equipment procedures index
- Set light switch main lever to B. O. DRIVE
- Put multimeter + lead on lead 19 contact and multimeter - lead on a good ground
- Read multimeter. Multimeter should measure +24 volts DC

Does multimeter measure less than +24 volts DC?

GO

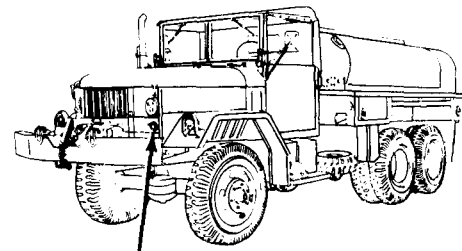

BLACKOUT HEADLAMP ASSEMBLY

ACCESSORY SWITCH

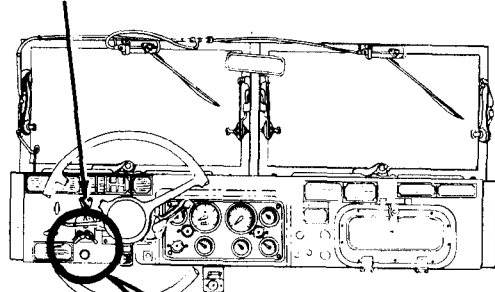

MAIN LEVER

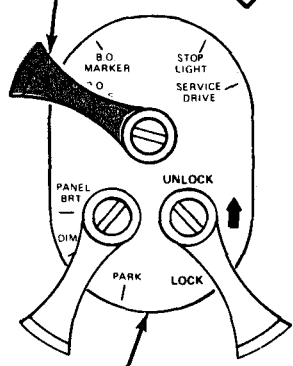

LIGHT SWITCH

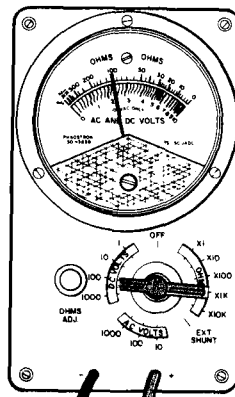

LEAD 19

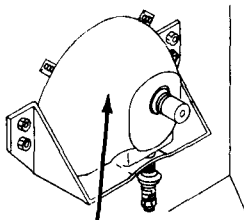

HOUSING

CONTACT

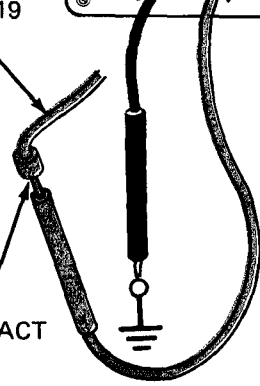

TA 114290

Figure 25-8 (Sheet 2 of 6)

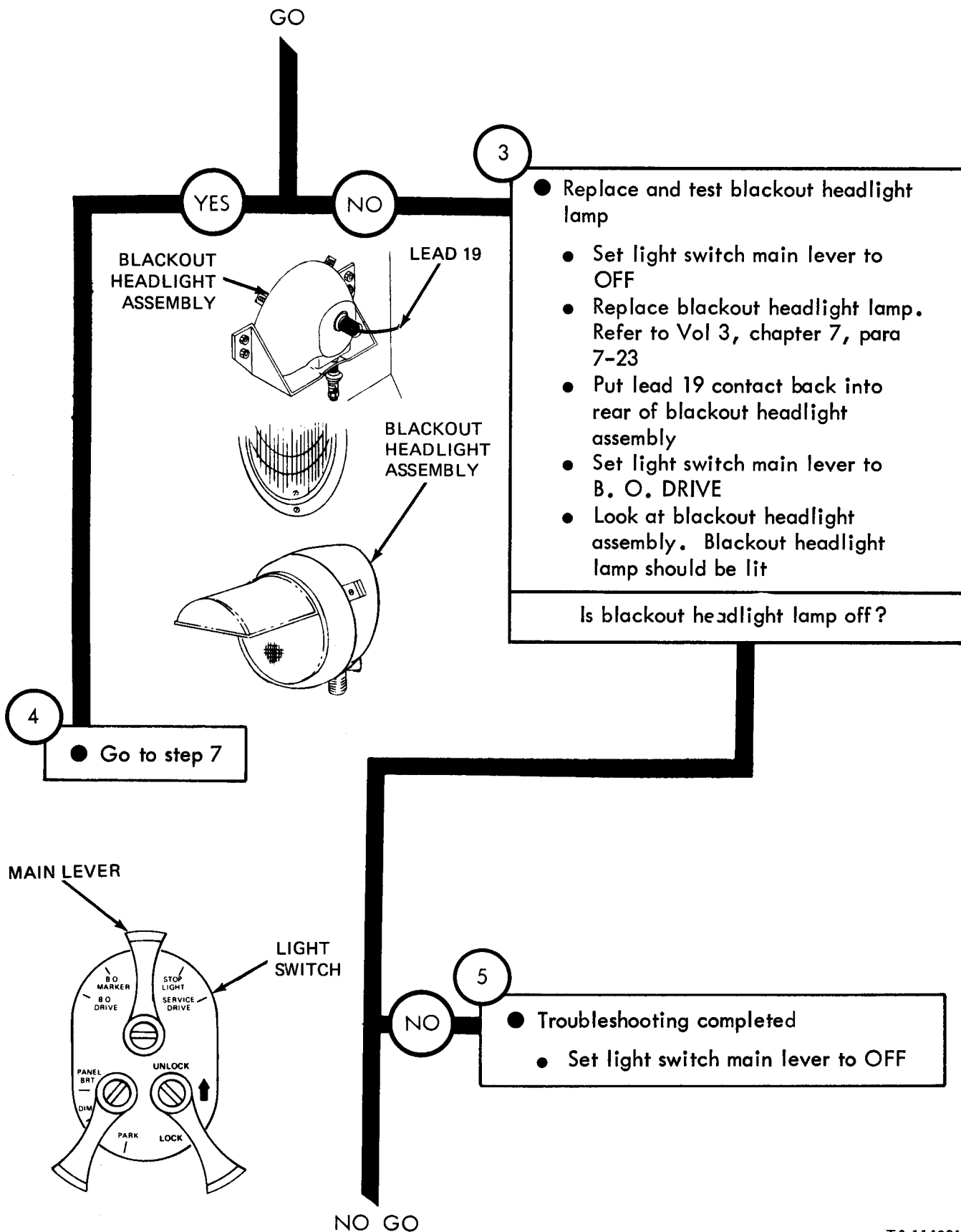
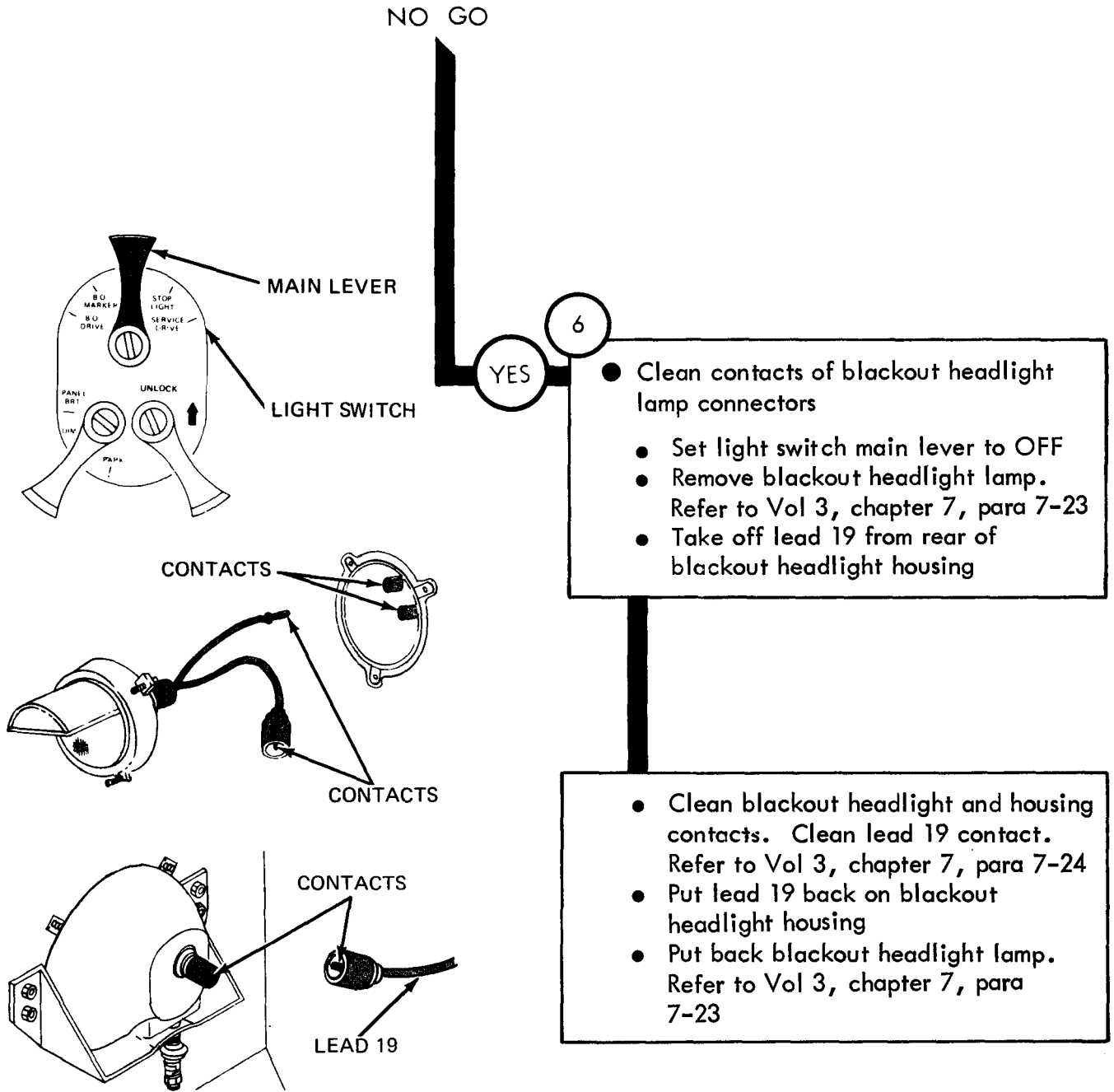

Figure 25-8 (Sheet 3 of 6)



TS 209-20-454

Figure 25-8 (Sheet 4 of 6)

From step 4

7

- Check front harness between light switch and blackout headlight assembly
 - Set light switch main lever to OFF
 - Take light switch off instrument panel. Refer to Vol 3, chapter 7, para 7-14
 - Take off light switch plug from light switch. Refer to Vol 3, chapter 7, para 7-14
 - Put jumper wire between contacts F and D of light switch plug on front harness

- Put multimeter + lead on front harness lead 19 contact and multimeter - lead on good ground
- Read multimeter. Multimeter should measure +24 volts DC

Does multimeter measure +24 volts DC ?

GO

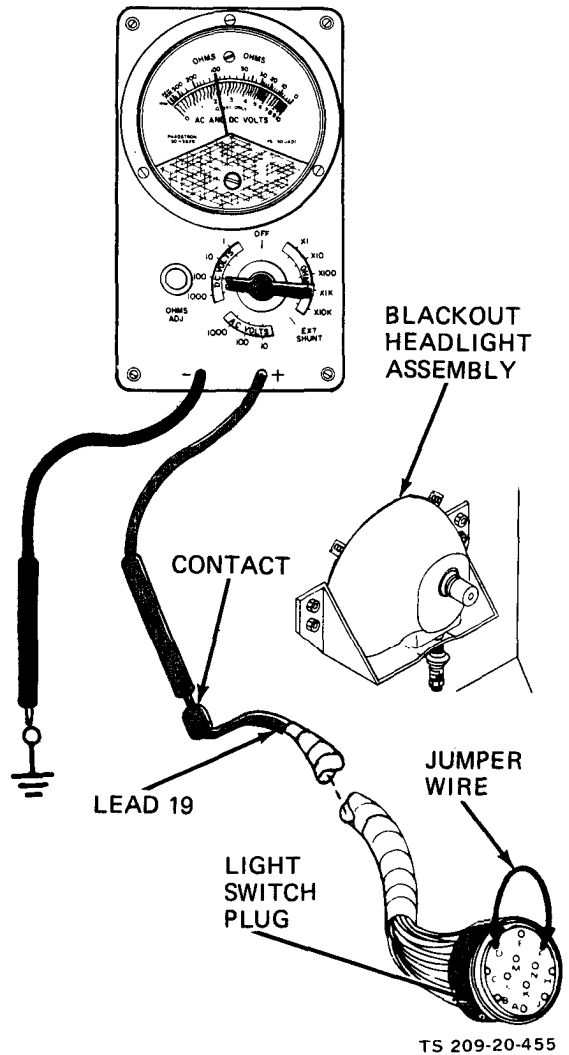

TS 209-20-455

TA 114293

Figure 25-8 (Sheet 5 of 6)

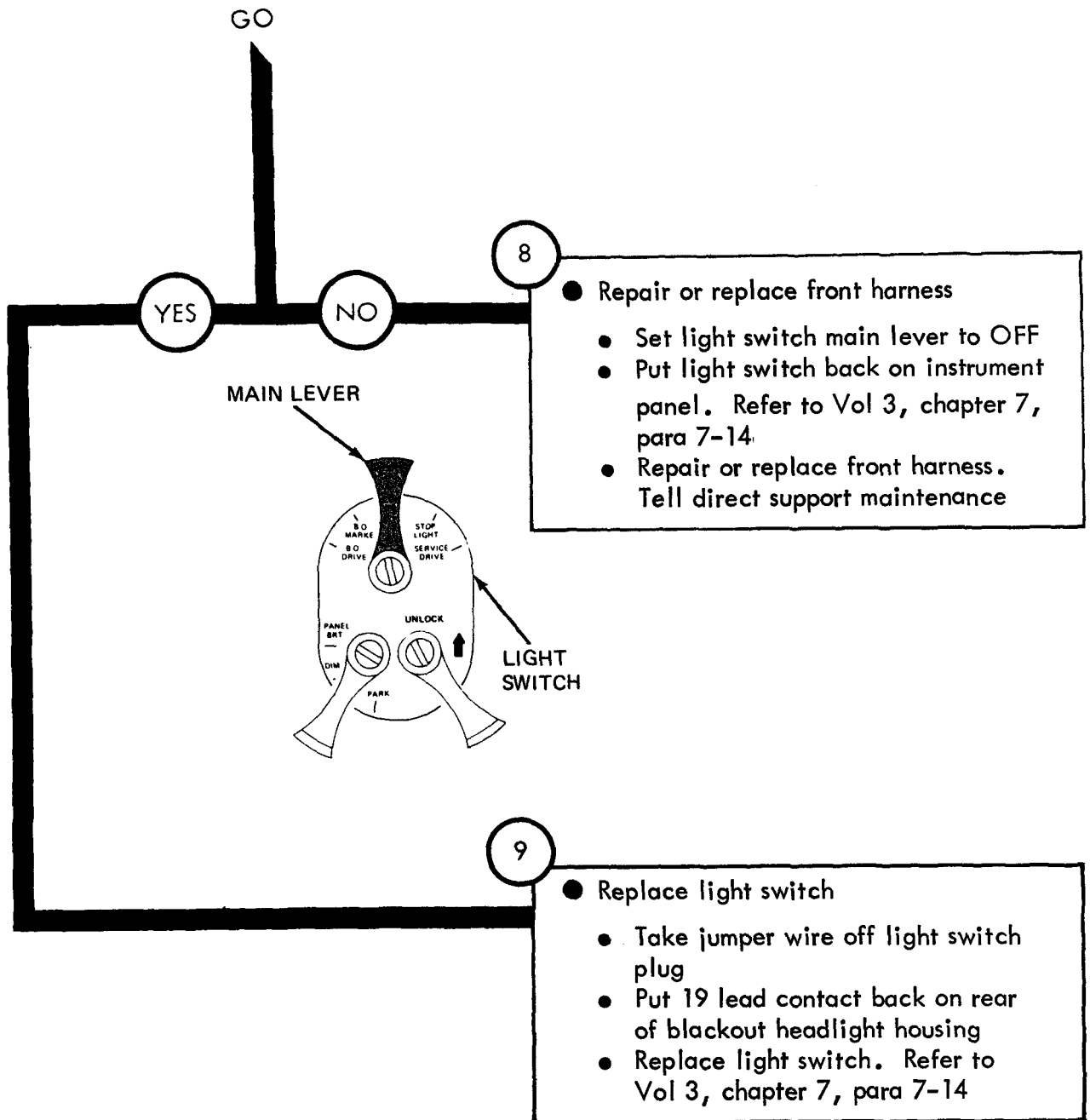

Figure 25-8 (Sheet 6 of 6)

Symptom

9 ONE OR BOTH FRONT BLACKOUT MARKER LAMPS DO NOT LIGHT, OTHER TRUCK RUNNING LIGHTS LIGHT

NOTE

Do this procedure for each front blackout marker lamp that does not light

When checking voltage +24 volts DC means a range of +23 volts DC to +26 volts DC

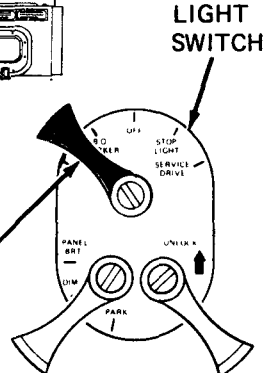
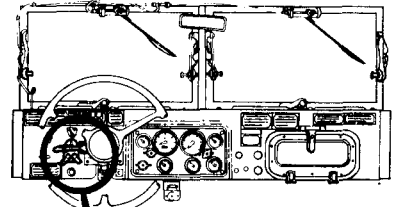
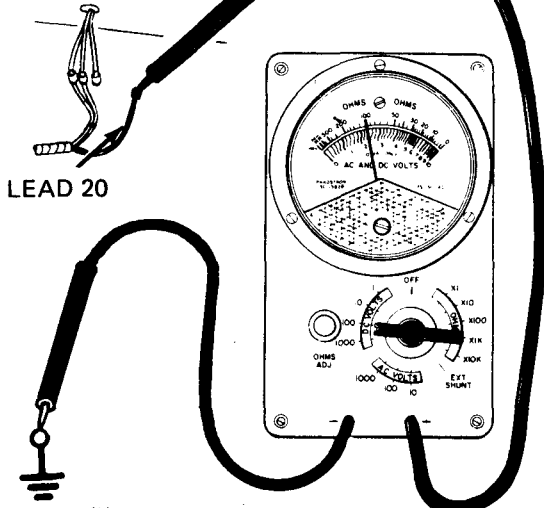
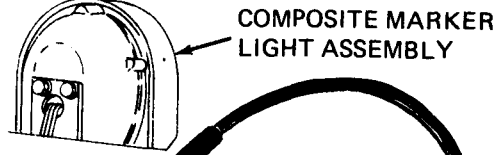
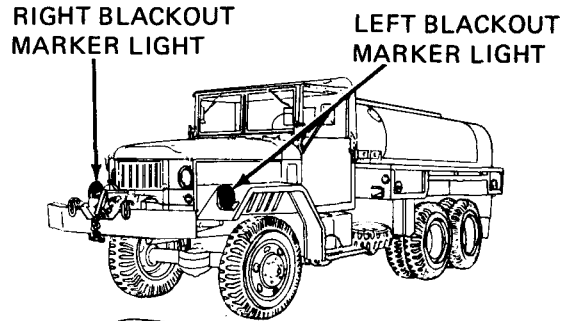

1

- Park truck
- Refer to TM 9-2320-209-10

2

- Check for +24 volts DC at front blackout marker lamp
 - Take off lead 20 at rear of front composite marker light assembly. Refer to Vol 3, chapter 7, para 7-40
 - Set multimeter to measure +24 volts DC. Refer to test equipment procedures index
 - Set light switch main lever to B.O. MARKER
 - Put multimeter + lead on lead 20 contact and - lead on a good ground
 - Read multimeter. Multimeter should measure +24 volts DC

Does multimeter measure less than +24 volts DC?

GO

TA 114295

Figure 25-9 (Sheet 1 of 5)

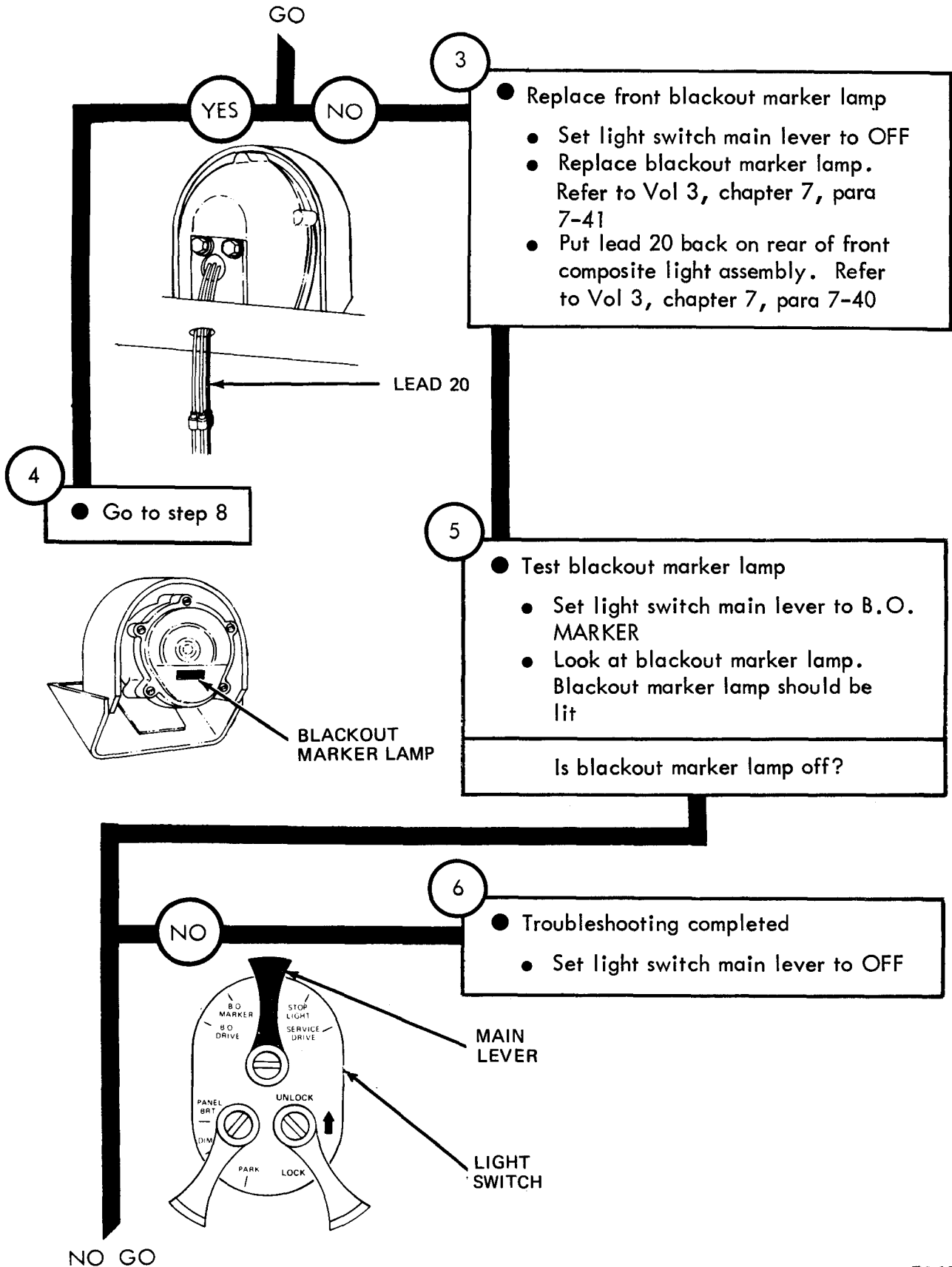

Figure 25-9 (Sheet 2 of 5)

NO GO



7

- Clean contacts of lead 20 connectors
 - Set light switch main lever to OFF
 - Remove blackout marker lamp. Refer to Vol 3, chapter 7, para 7-41
 - Take off lead 20 at rear of front composite marker light assembly. Refer to Vol 3, chapter 7, para 7-40

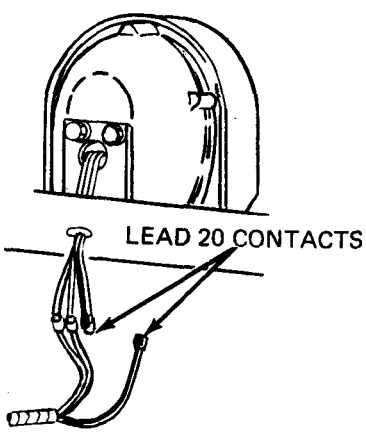
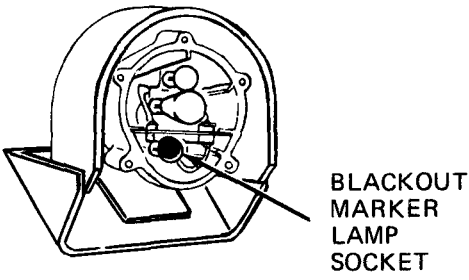
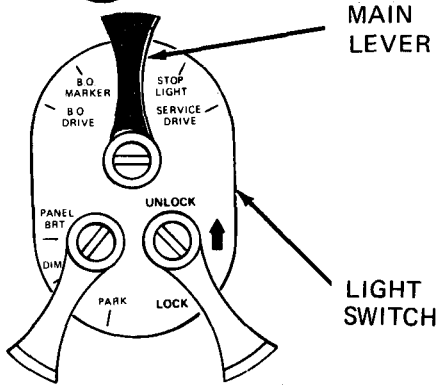

- Clean blackout marker lamp socket and clean lead 20 contacts. Refer to Vol 3, chapter 7, para 7-42
- Put lead 20 back on rear of front composite marker light assembly. Refer to Vol 3, chapter 7, para 7-40
- Put back blackout marker lamp. Refer to Vol 3, chapter 7, para 7-41

TS 209-20-459

Figure 25-9 (Sheet 3 of 5)

From step 4

8

- Check wiring harness between blackout marker lamp and light switch
 - Set light switch main lever to OFF
 - Take off light switch from instrument panel. Refer to Vol 3, chapter 7, para 7-14. Take off light switch plug from light switch
 - Put jumper wire between terminals F and E of light switch plug on front harness
 - Put multimeter + lead on front harness lead 20 contact and - lead on a good ground. Read multimeter

Does multimeter measure +24 volts DC ?

GO

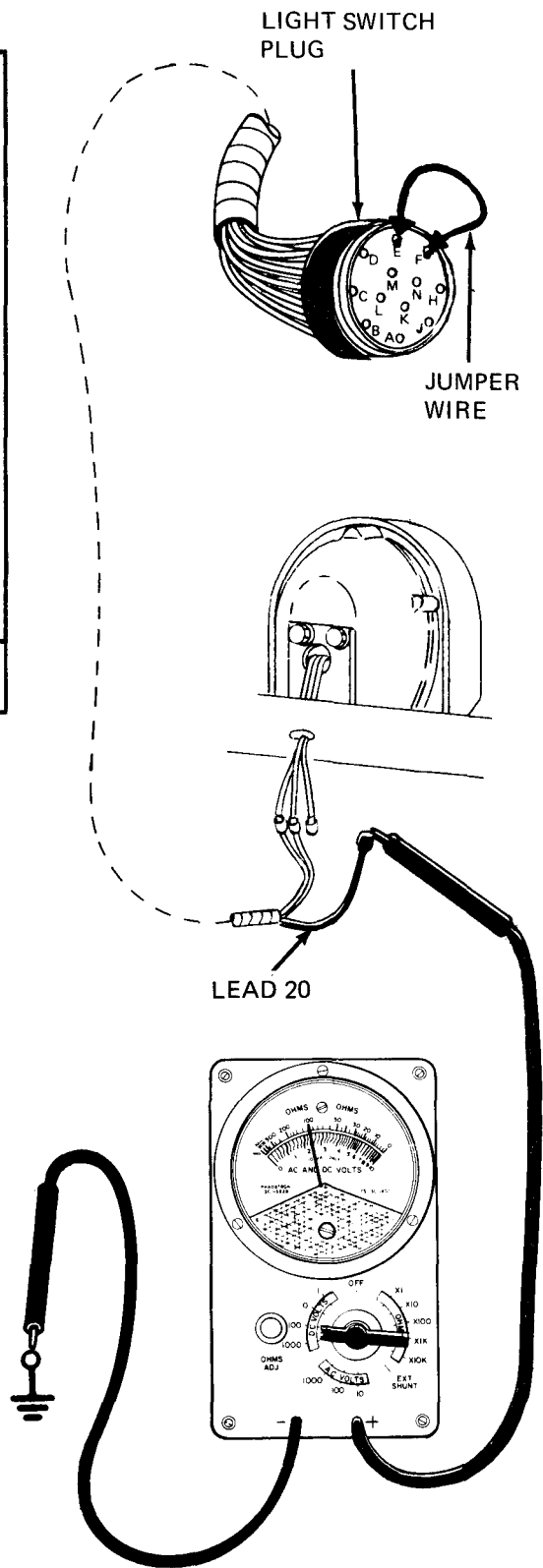

Figure 25-9 (Sheet 4 of 5)

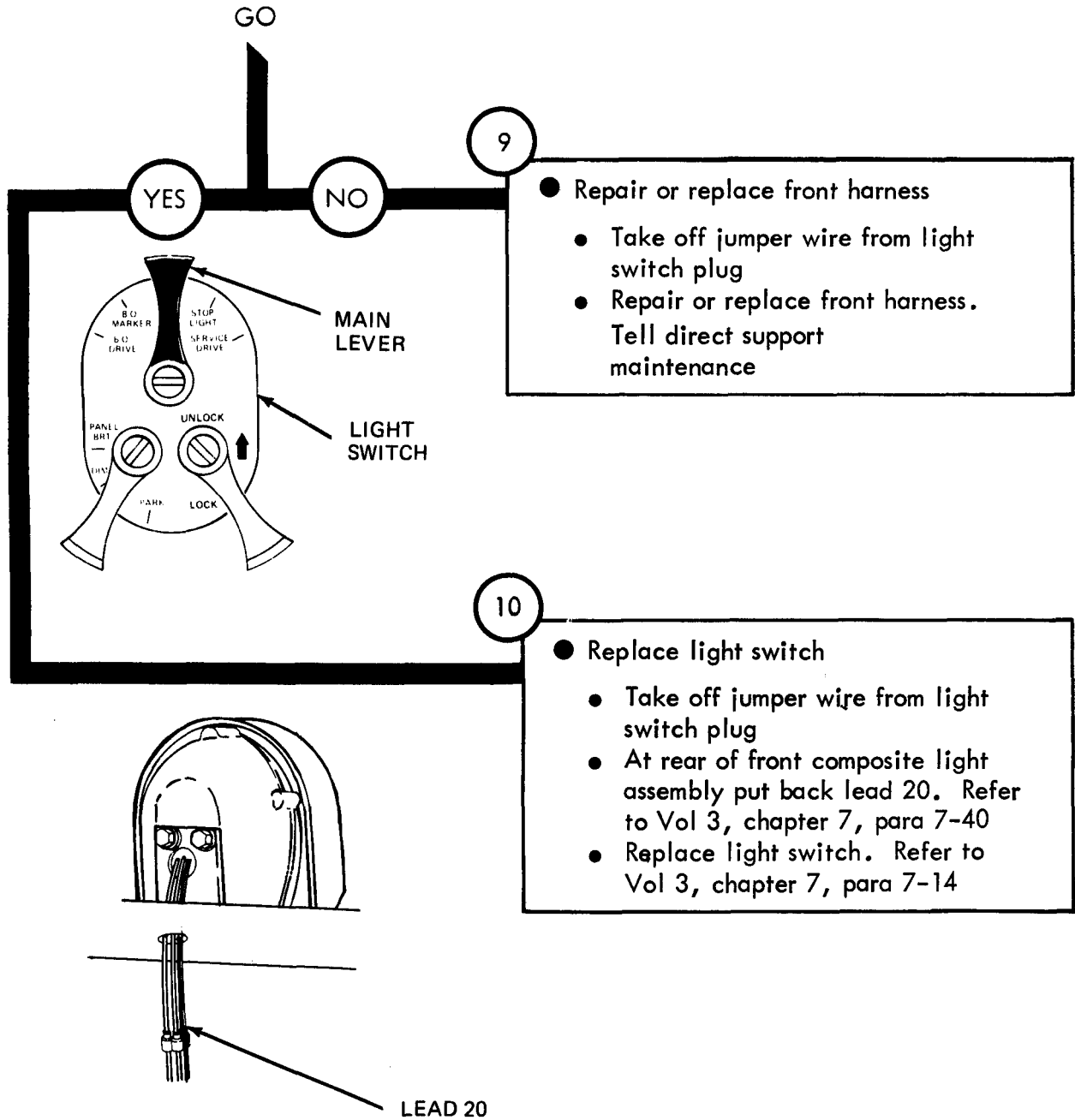

Figure 25-9 (Sheet 5 of 5)

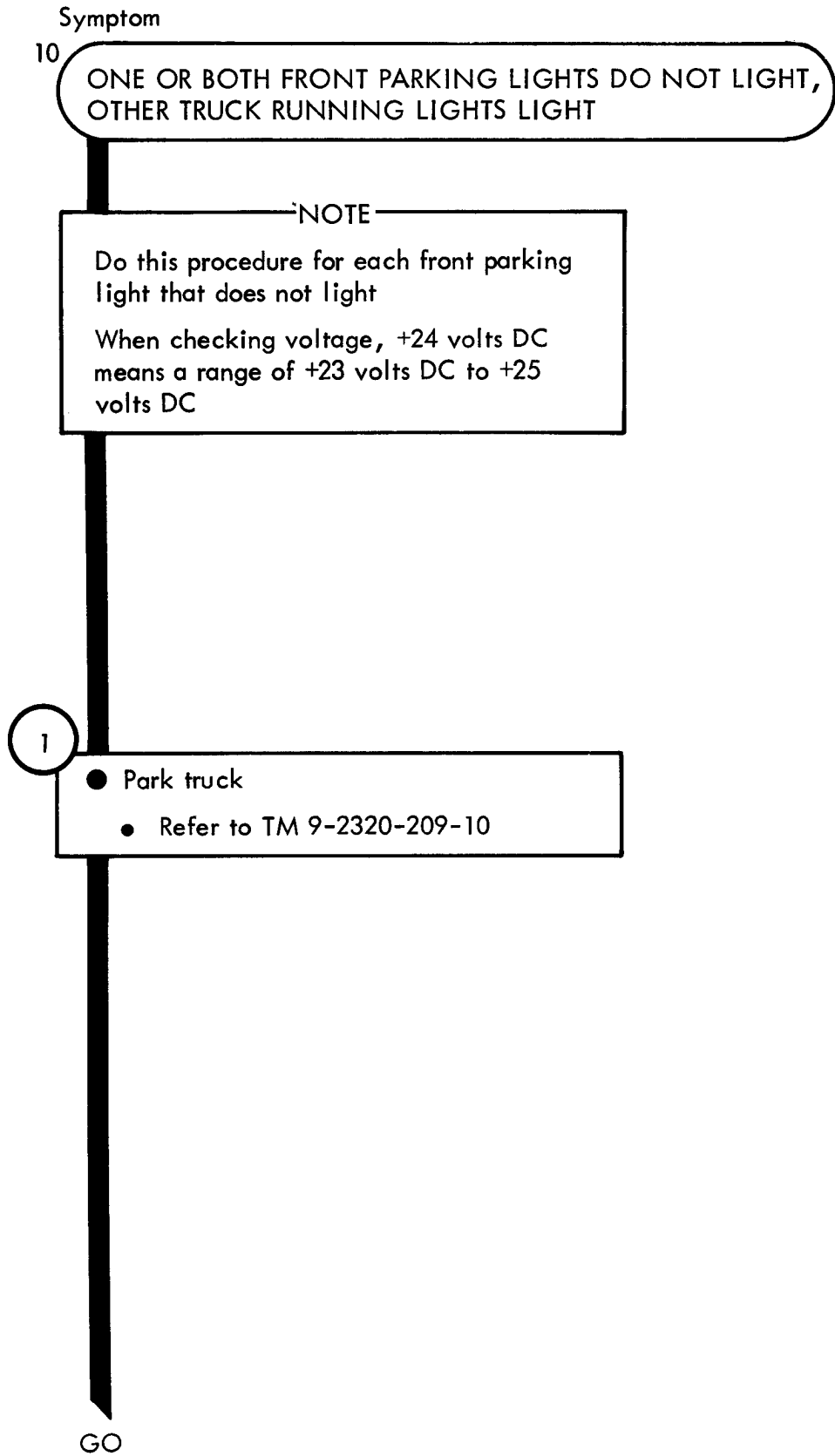
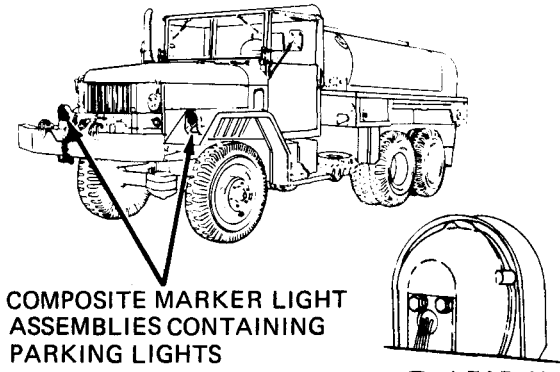

Figure 25-10 (Sheet 1 of 6)

GO



2

- Check for +24 volts DC at front parking light
- Take off lead 491 at front composite marker light assembly. Refer to Vol 3, chapter 7, para 7-40
- Set multimeter to measure +24 volts DC. Refer to test equipment procedures index
- Set light switch main lever to SERVICE DRIVE. Set light switch auxiliary lever to PARK
- Put multimeter + lead on lead 491 and multimeter - lead on a good ground
- Read multimeter. Multimeter should measure +24 volts DC

Does multimeter measure less than +24 volts DC?

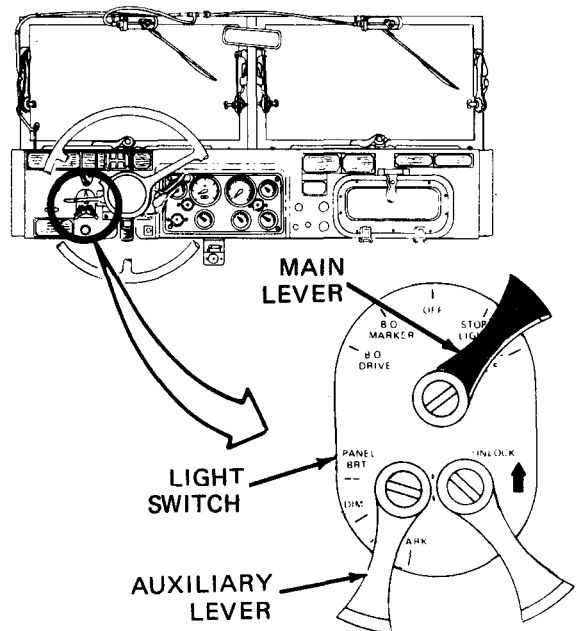
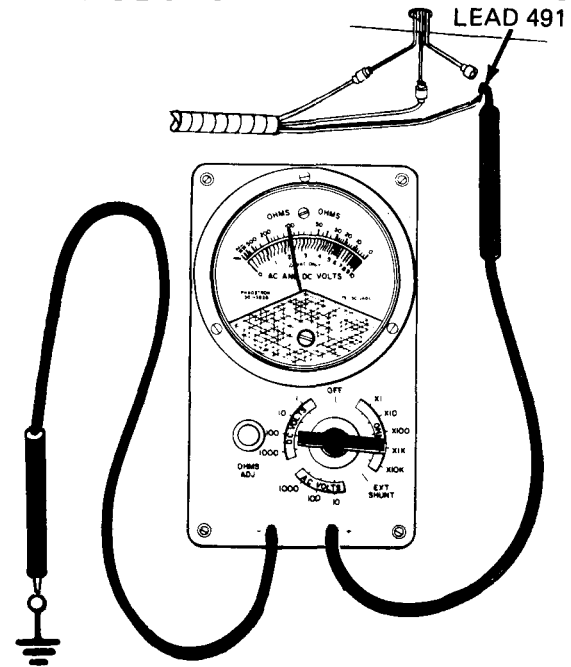

GO

TA 114301

Figure 25-10 (Sheet 2 of 6)

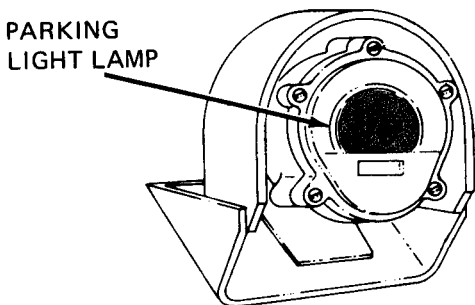
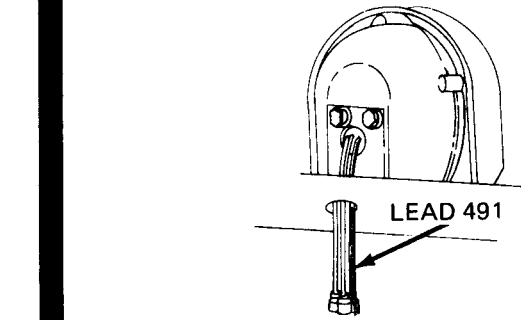
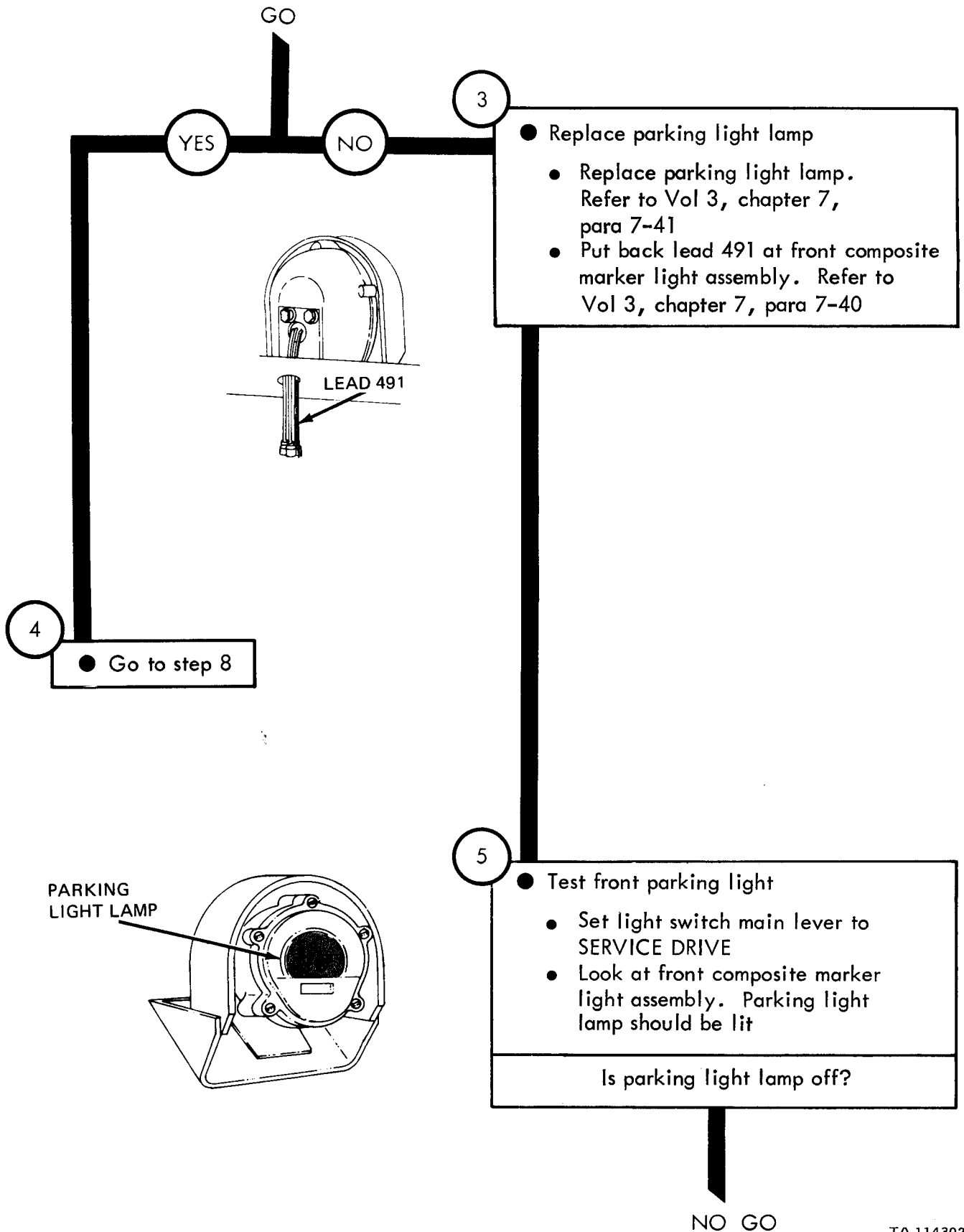

Figure 25-10 (Sheet 3 of 6)

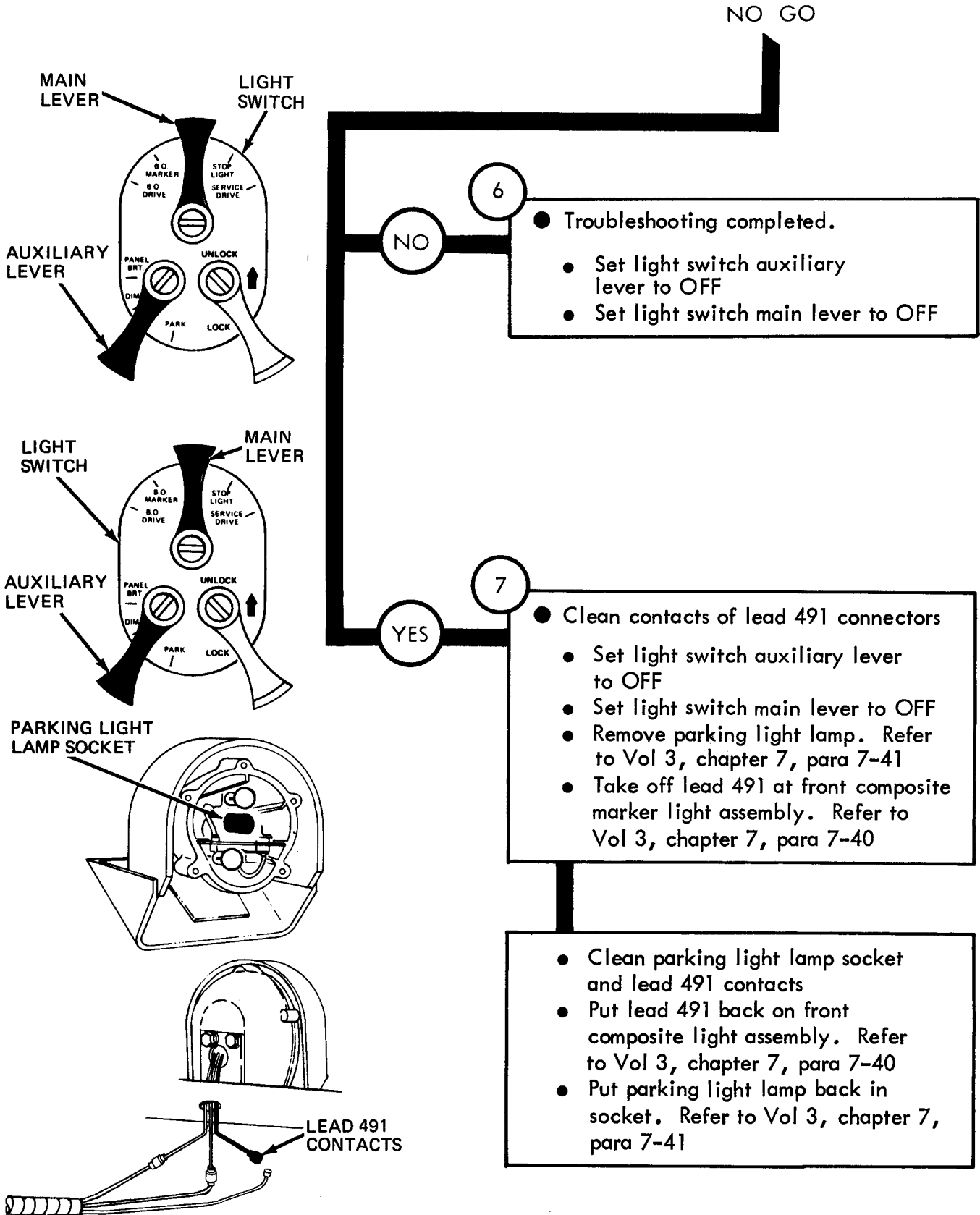

Figure 25-10 (Sheet 4 of 6)

From step 4

8

- Check wiring harness between parking light lamp and light switch
 - Take off light switch from instrument panel. Refer to Vol 3, chapter 7, para 7-14. Take off light switch plug from light switch. Refer to Vol 3, chapter 7, para 7-14
 - Put jumper wire between contacts F and L of light switch plug
 - Put multimeter - lead on a good ground and + lead on lead 491 contact.
 - Read multimeter. Multimeter should measure +24 volts DC

Does multimeter measure +24 volts DC?

GO

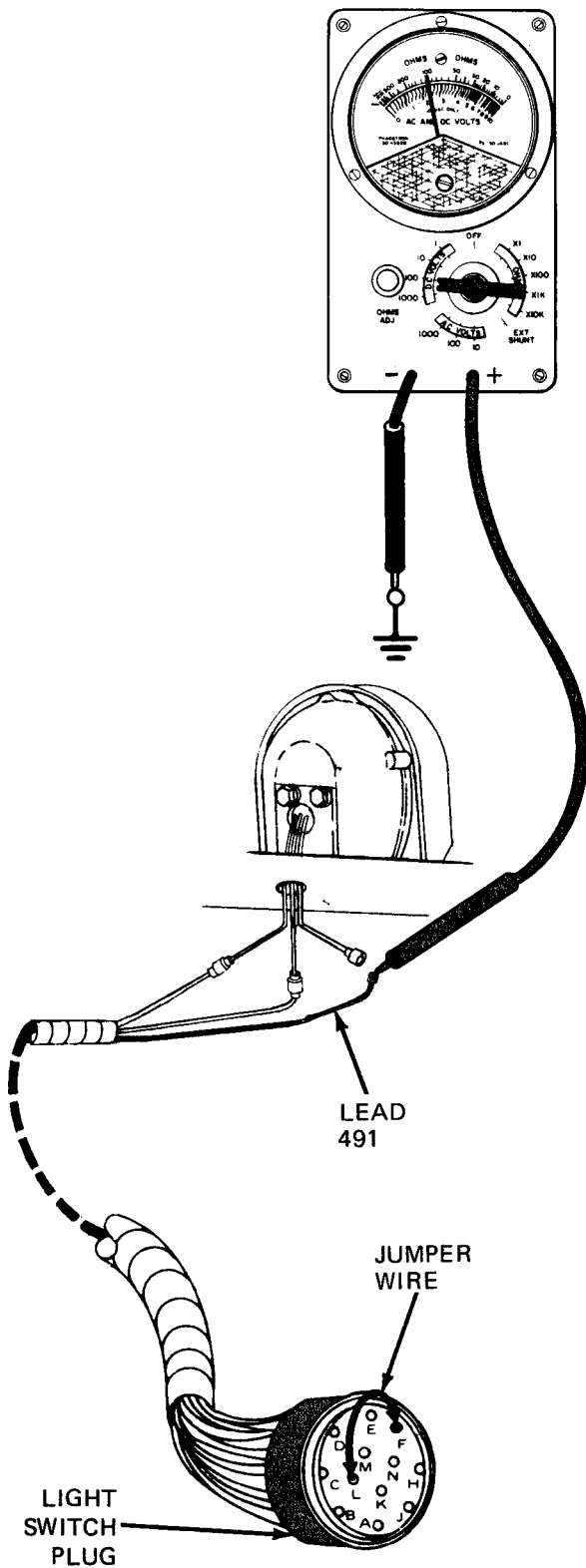
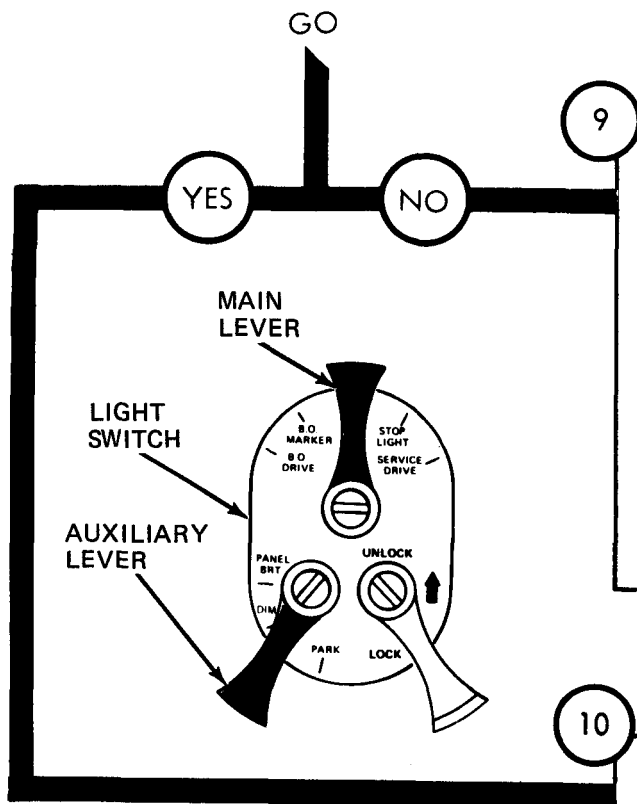
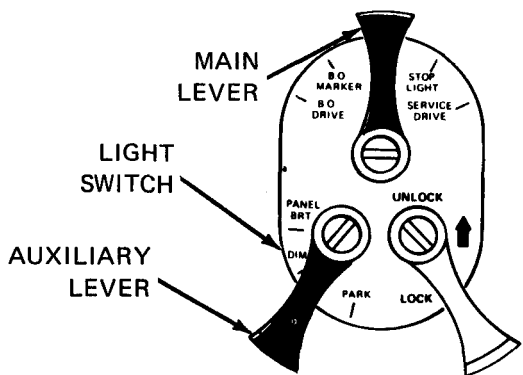

Figure 25-10 (Sheet 5 of 6)



- Repair or replace front harness
 - Set light switch auxiliary lever to OFF
 - Set light switch main lever to OFF
 - Take off jumper wire from light switch plug
 - Put light switch back on instrument panel. Refer to Vol 3, chapter 7, para 7-14
 - Repair or replace front harness. Tell direct support maintenance



- Replace light switch
 - Set light switch auxiliary lever to OFF
 - Set light switch main lever to OFF
 - Take off jumper wire from light switch plug
 - At front composite light assembly put back lead 491. Refer to Vol 3, chapter 7, para 7-40
 - Replace light switch. Refer to Vol 3, chapter 7, para 7-14

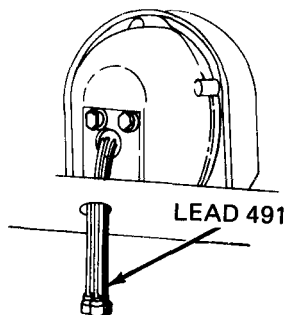

Figure 25-10 (Sheet 6 of 6)

Symptom

11

ONE REAR SERVICE STOPLIGHT DOES NOT LIGHT, OTHER STOPLIGHT LIGHTS

NOTE

Two soldiers are needed to troubleshoot a stoplight. SOLDIER A sits in cab and operates controls. SOLDIER B makes voltage checks with the multimeter

When checking voltage, +24 volts DC means a range of +23 volts DC to +26 volts DC

1

- Park truck
- Refer to TM 9-2320-209-10

2

- Check for +24 volts DC at stoplight
- SOLDIER B:
- Using 9/16-inch wrench, unscrew and take off four screws with washers from rear composite marker assembly
 - Take off cover
 - Take off lead 22-461 (left service stoplight) or lead 22-460 (right service stoplight)

GO

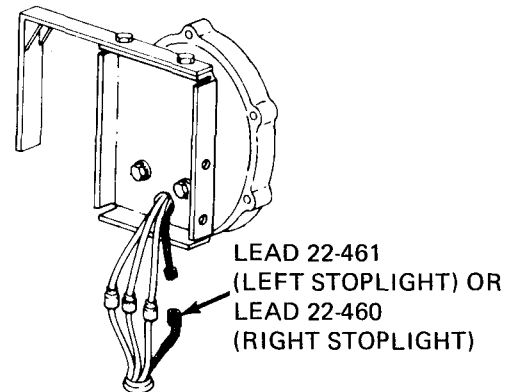
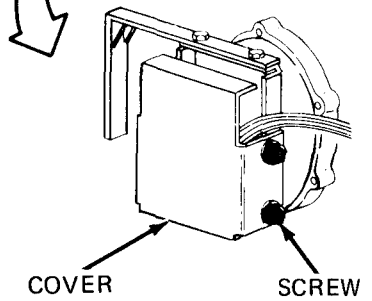
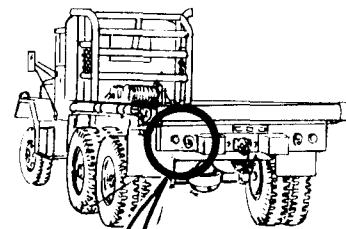

Figure 25-11 (Sheet 1 of 10)

GO

SOLDIER A:

- Set light switch main lever to STOPLIGHT
- Make sure turn signal control handle is in neutral position

SOLDIER B:

- Set multimeter to measure +24 volts DC. Refer to test equipment procedures index

SOLDIER B:

- Put multimeter - lead on good ground. Put multimeter + lead on lead 22-461 (left service stoplight) or 22-460 (right service stoplight)

SOLDIER A:

- Press down on brake pedal and hold it

SOLDIER B:

- Read multimeter while Soldier A presses down on brake pedal. Multimeter should measure +24 volts DC

Does multimeter measure less than +24 volts DC?

GO

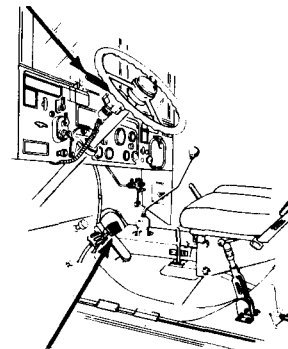
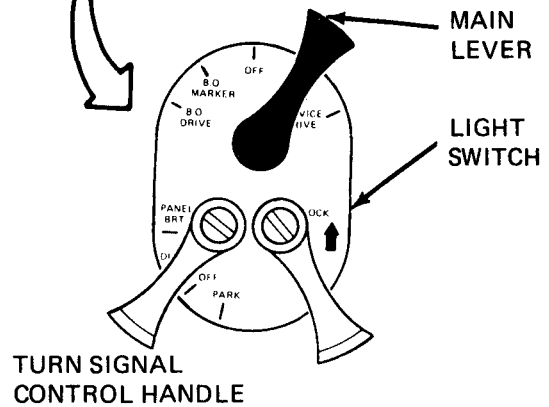
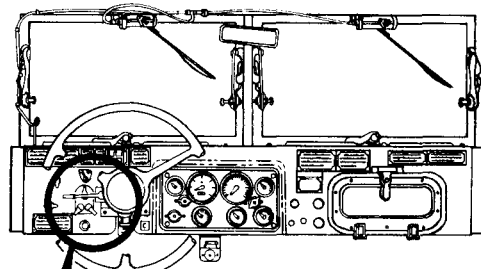

BRAKE PEDAL

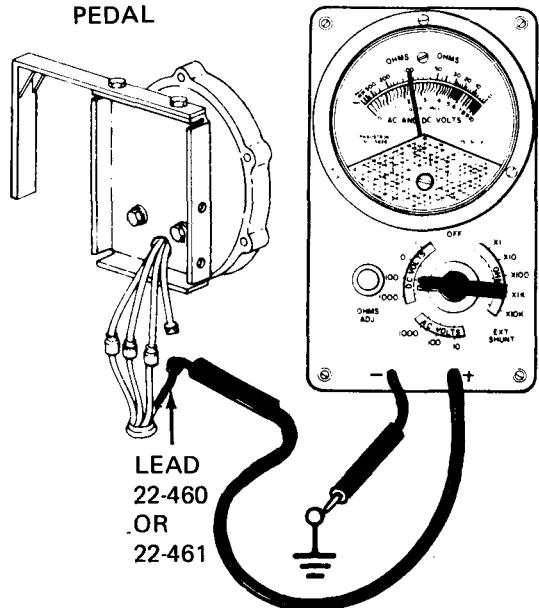

TA 114307

Figure 25-11 (Sheet 2 of 10)

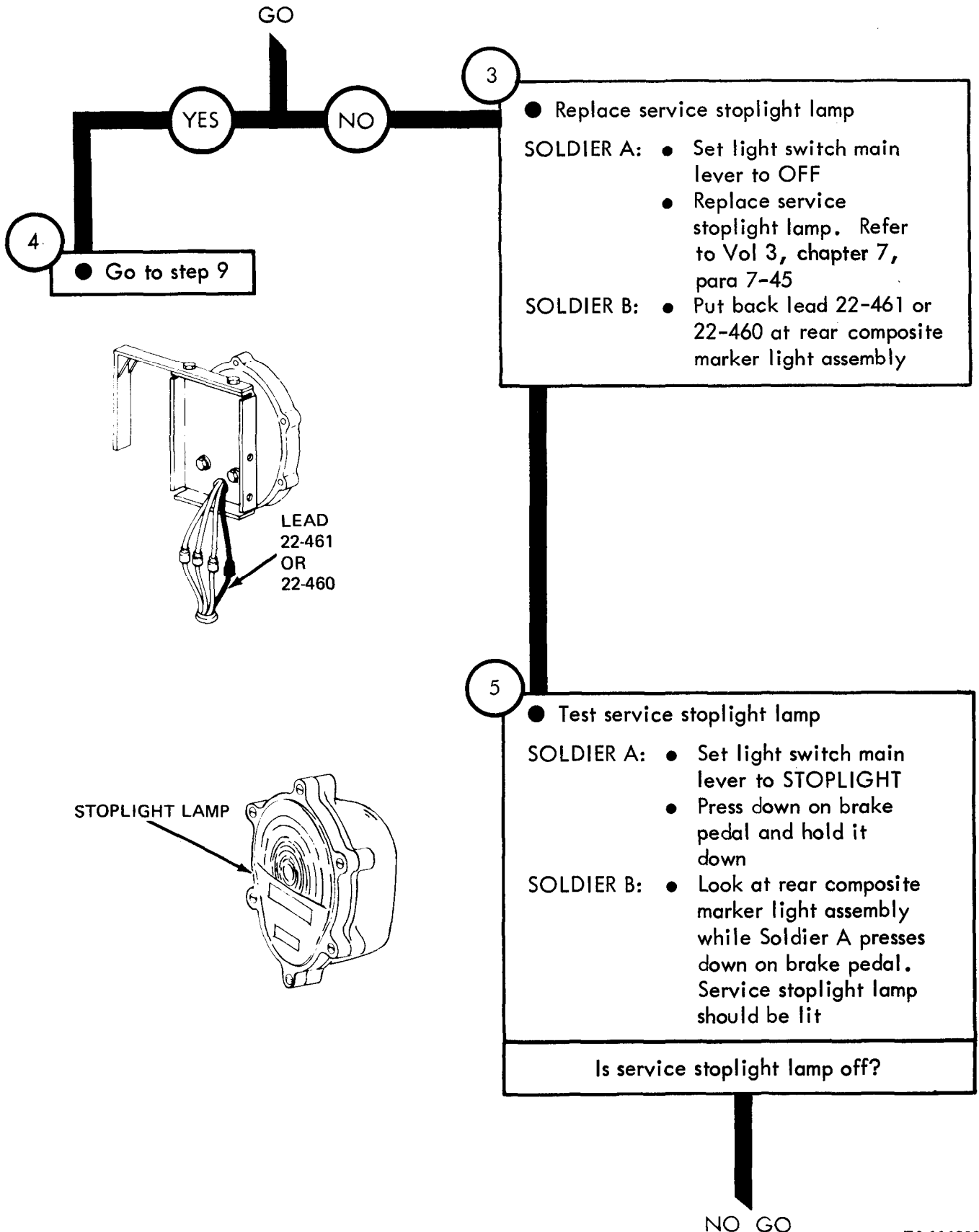

Figure 25-11 (Sheet 3 of 10)

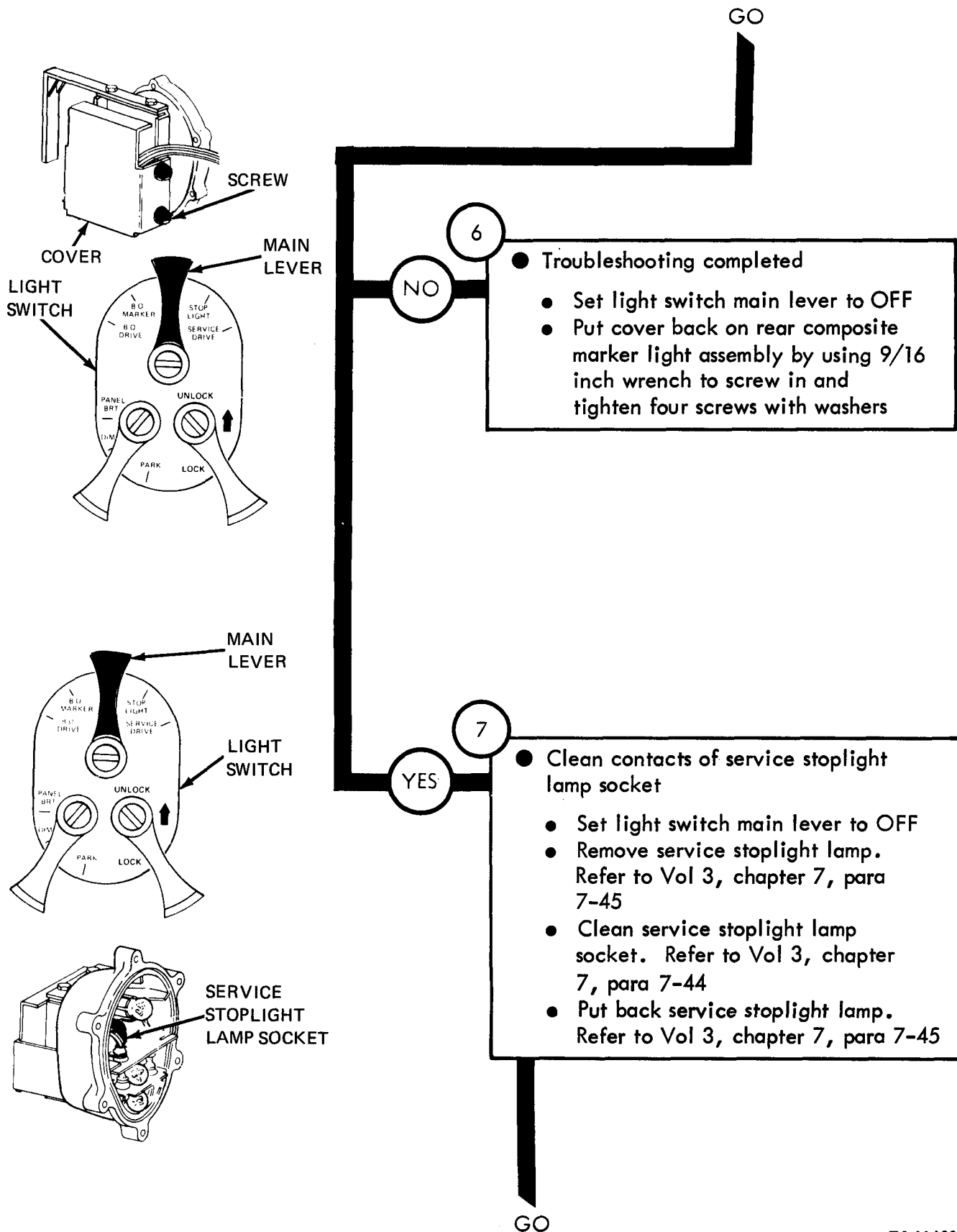
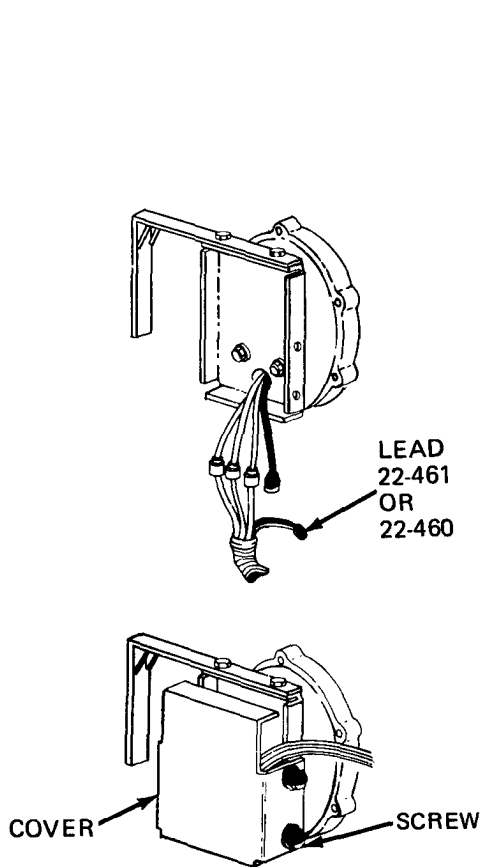

Figure 25-11 (Sheet 4 of 10)



GO

8

- Clean contacts of stoplight lamp connectors
 - Take off lead 22-461 (left service stoplight) or 22-460 (right service stoplight)
 - Clean lead 22-461 or 22-460 contact
 - Push lead 22-461 or 22-460 into connector
 - Put cover back on rear composite marker light assembly by using 9/16-inch wrench to screw in and tighten four screws with washers

Figure 25-11 (Sheet 5 of 10)

From step 4

9

- Check rear harness between service stoplight lamp and rear harness connector
- SOLDIER A: ● Set light switch main lever to OFF
- SOLDIER B: ● Unscrew and take off rear harness plug from front harness receptacle
- SOLDIER A: ● Set light switch main lever to STOPLIGHT
- SOLDIER B: ● Put multimeter - lead on good ground

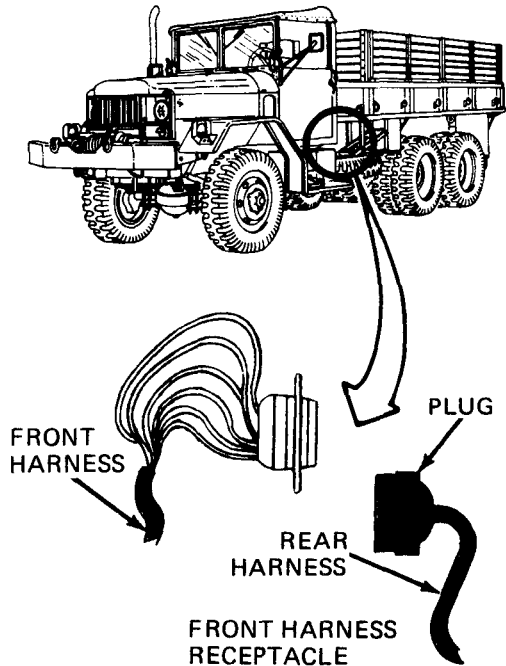

- SOLDIER B: ● For left service stoplight, put multimeter + lead on contact C in front harness receptacle. For right service stoplight, put multimeter + lead on contact G in front harness receptacle
- SOLDIER A: ● Press down on brake pedal and hold it down
- SOLDIER B: ● Read multimeter while Soldier A presses down on brake pedal. Multimeter should read +24 volts DC

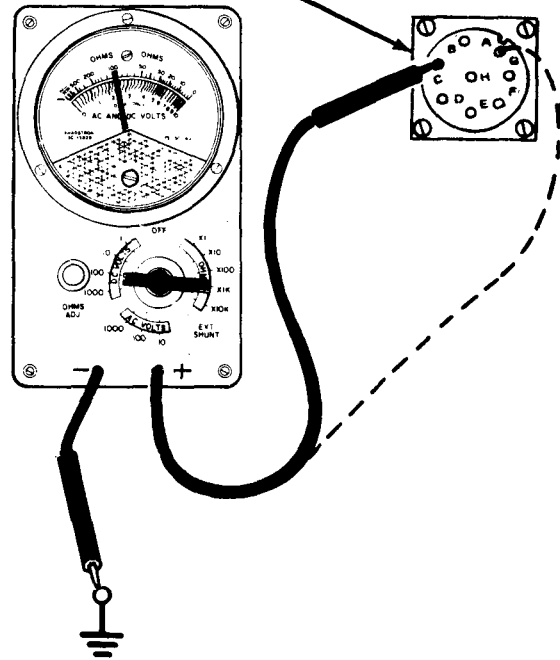

Does multimeter read less than +24 volts DC?

GO

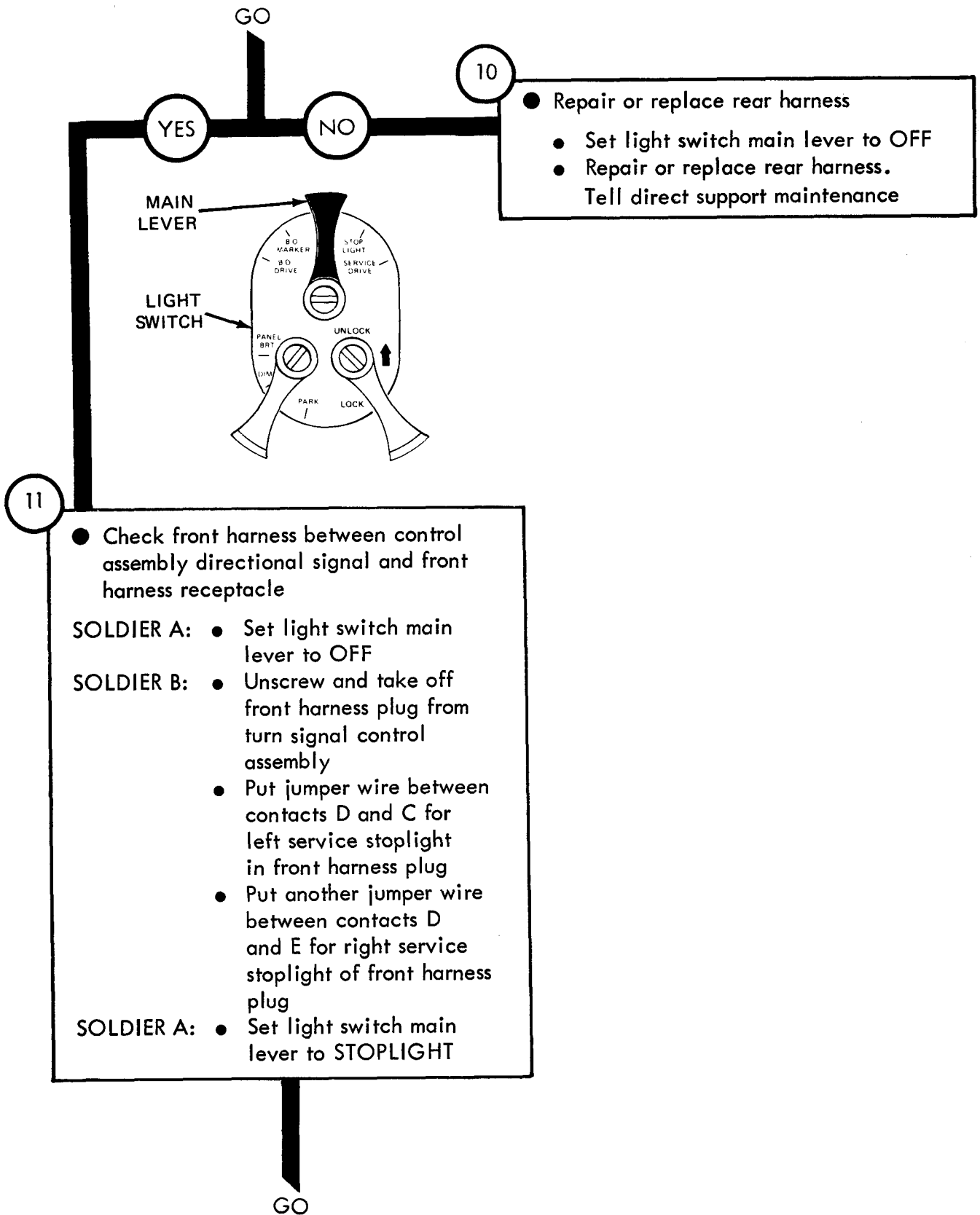

Figure 25-11 (Sheet 7 of 10)

GO

SOLDIER B:

- Put multimeter - lead on a good ground
- For left service stoplight, put multimeter + lead on contact C in front harness receptacle. For right service stoplight, put multimeter + lead on contact G of front harness receptacle

SOLDIER A:

- Press down on brake pedal and hold it down

SOLDIER B:

- Read multimeter while Soldier A presses on brake pedal. Multimeter should read +24 volts DC

Does multimeter read +24 volts DC?

GO

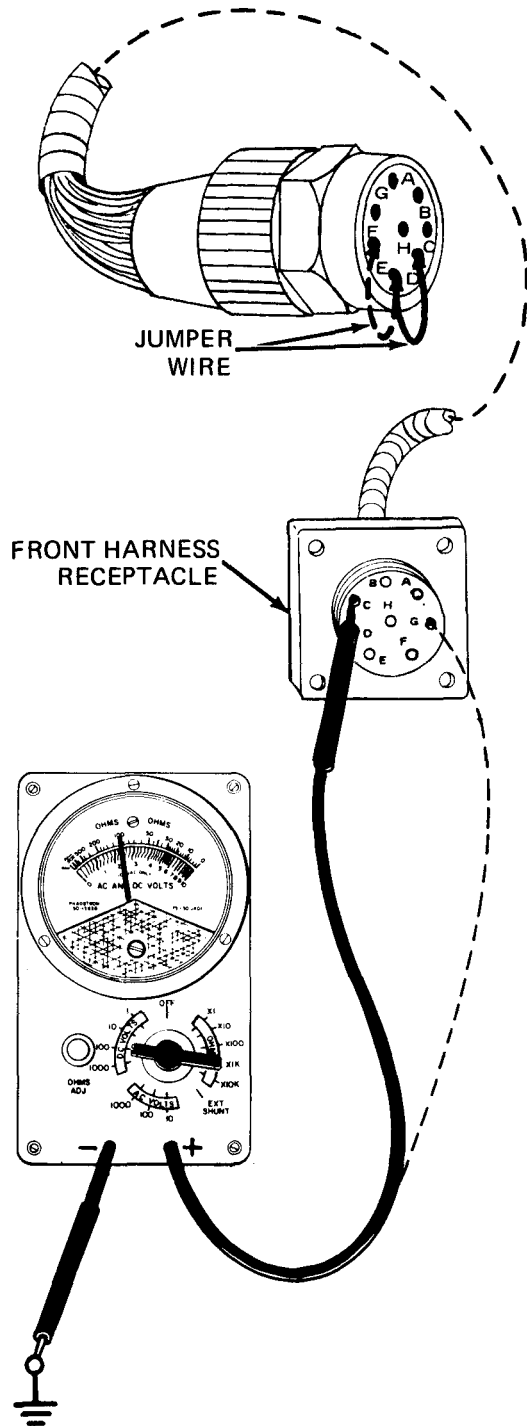

TA 114313

Figure 25-11 (Sheet 8 of 10)

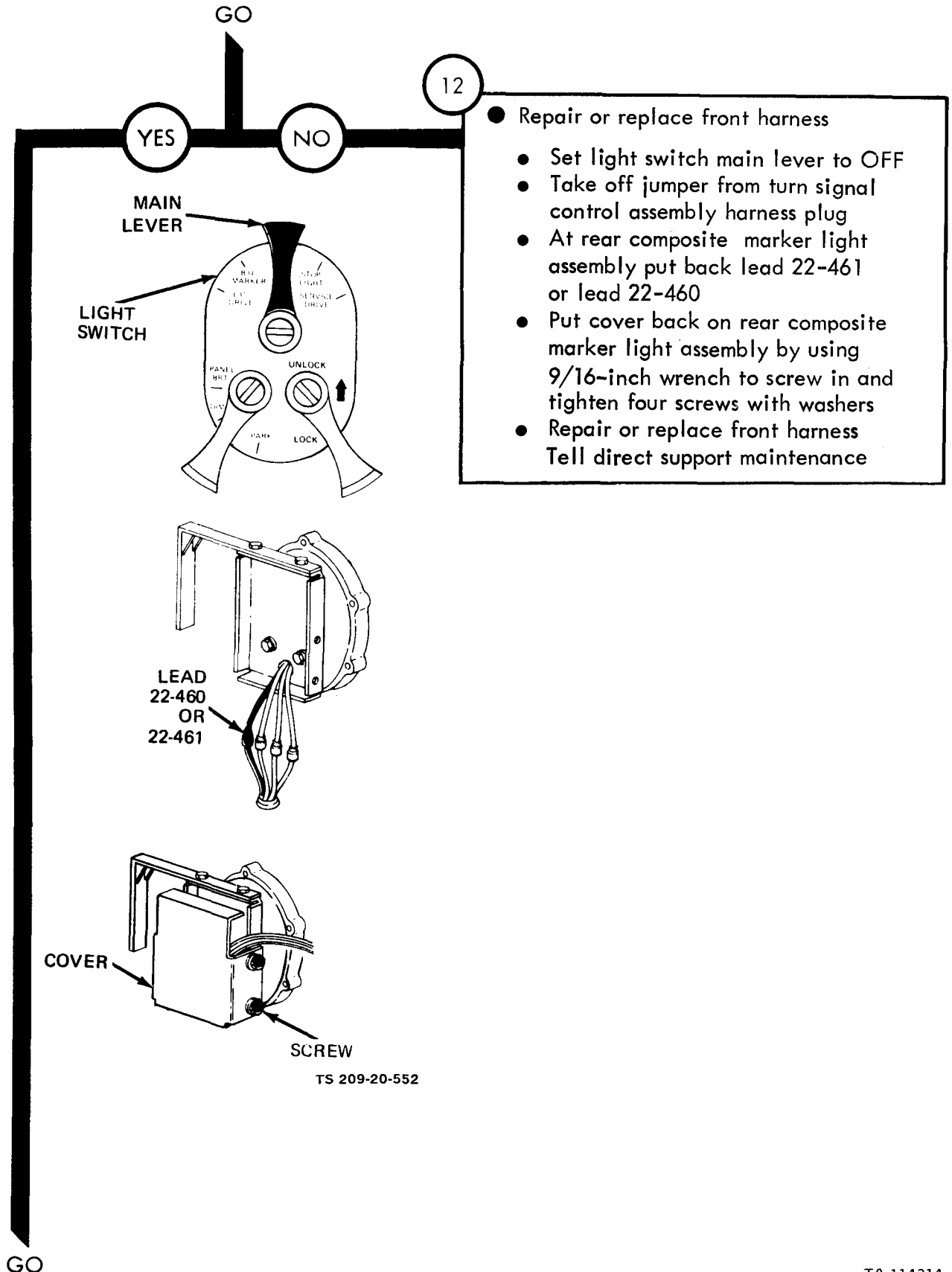

- Repair or replace front harness
 - Set light switch main lever to OFF
 - Take off jumper from turn signal control assembly harness plug
 - At rear composite marker light assembly put back lead 22-461 or lead 22-460
 - Put cover back on rear composite marker light assembly by using 9/16-inch wrench to screw in and tighten four screws with washers
 - Repair or replace front harness
- Tell direct support maintenance

Figure 25-11 (Sheet 9 of 10)

GO

13

- Replace turn signal control assembly
 - Set light switch main lever to OFF
 - Take off jumper assembly harness plug
 - Put rear harness plug back on front harness receptacle

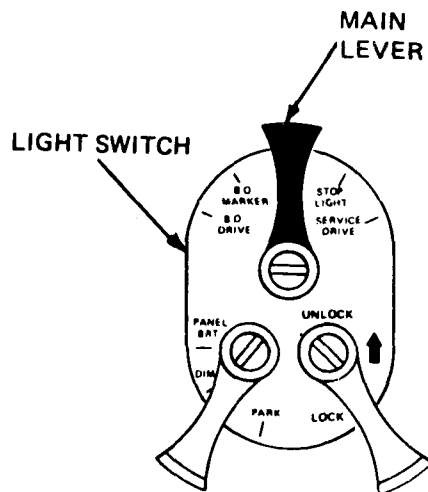
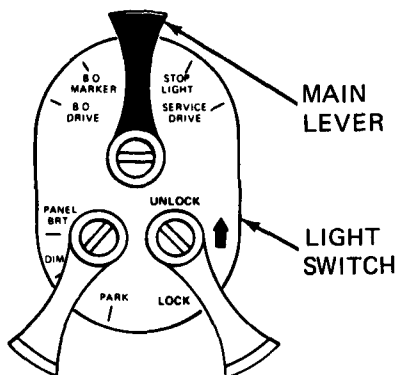

- At rear composite marker light assembly put back 22-461 or 22-460
- Put cover back on rear composite marker light assembly by using 9/16-inch wrench to screw in and tighten four screws with washers
- Replace turn signal control assembly put back lead 22-461 or 22-460

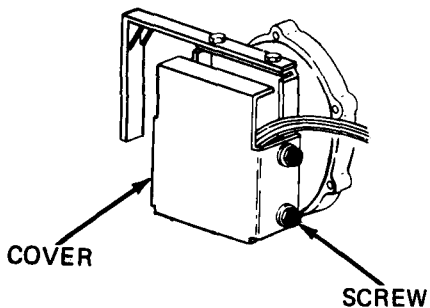

Figure 25-11 (Sheet 10 of 10)

Symptom

12 BOTH SERVICE STOPLIGHTS DO NOT LIGHT, OTHER TRUCK RUNNING LIGHTS LIGHT

NOTE

Two soldiers are needed to troubleshoot rear service stoplights. Soldier A sits in the cab and operates the controls. Soldier B makes voltage checks with the multimeter

When checking voltage, +24 volts DC means a range of +23 to +26 volts DC

- 1
- Park truck
 - Refer to TM 9-2320-209-10

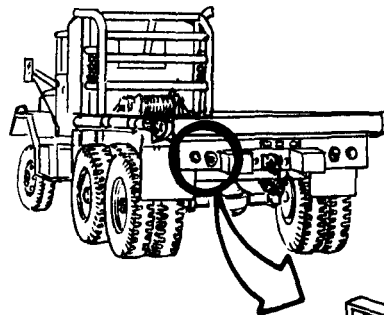

- 2
- Check for +24 volts DC at left service stoplight
- SOLDIER B:
- Using 9/16-inch wrench, unscrew and take off four screws with washers from left rear composite marker assembly
 - Take off cover
 - Take off lead 22-461

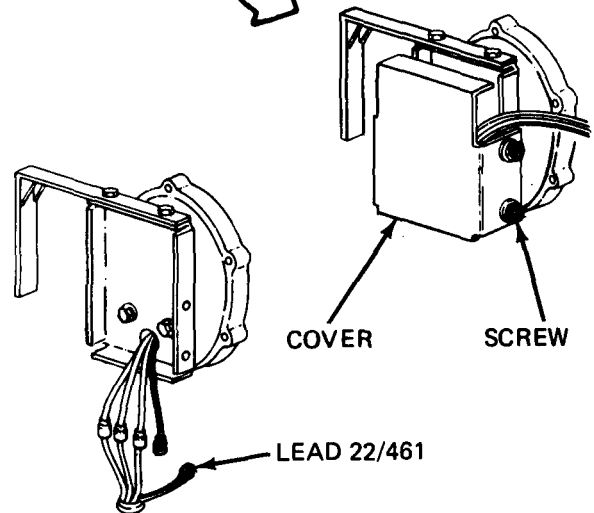

GO

TA 114316

Figure 25-12 (Sheet 1 of 15)

GO

SOLDIER A:

- Set light switch main lever to STOPLIGHT position
- Make sure turn signal control lever is in neutral position

SOLDIER B:

- Set multimeter to measure +24 volts DC. Refer to test equipment procedures index

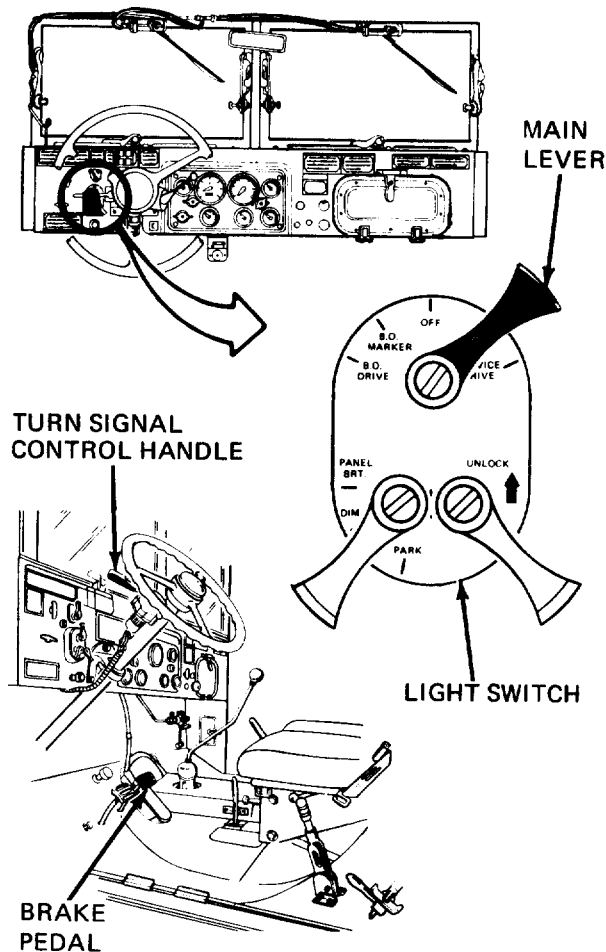

SOLDIER B:

- Put multimeter + lead on lead 22-461
- Put multimeter - lead on a good ground

SOLDIER A:

- Press down on brake pedal and hold it down

SOLDIER B:

- Read multimeter while Soldier A presses down on brake pedal. Multimeter should measure +24 volts DC

Does multimeter measure less than +24 volts DC?

GO

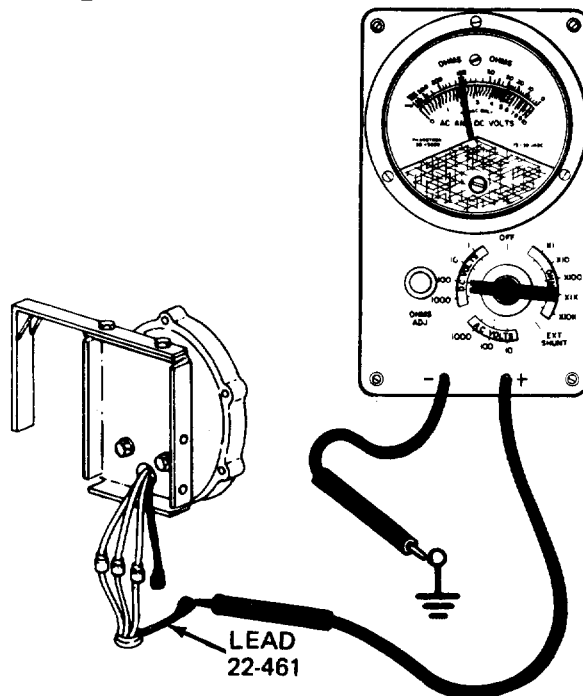

TA 114317

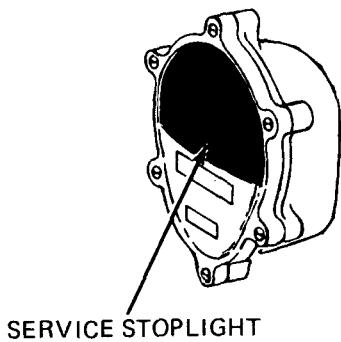
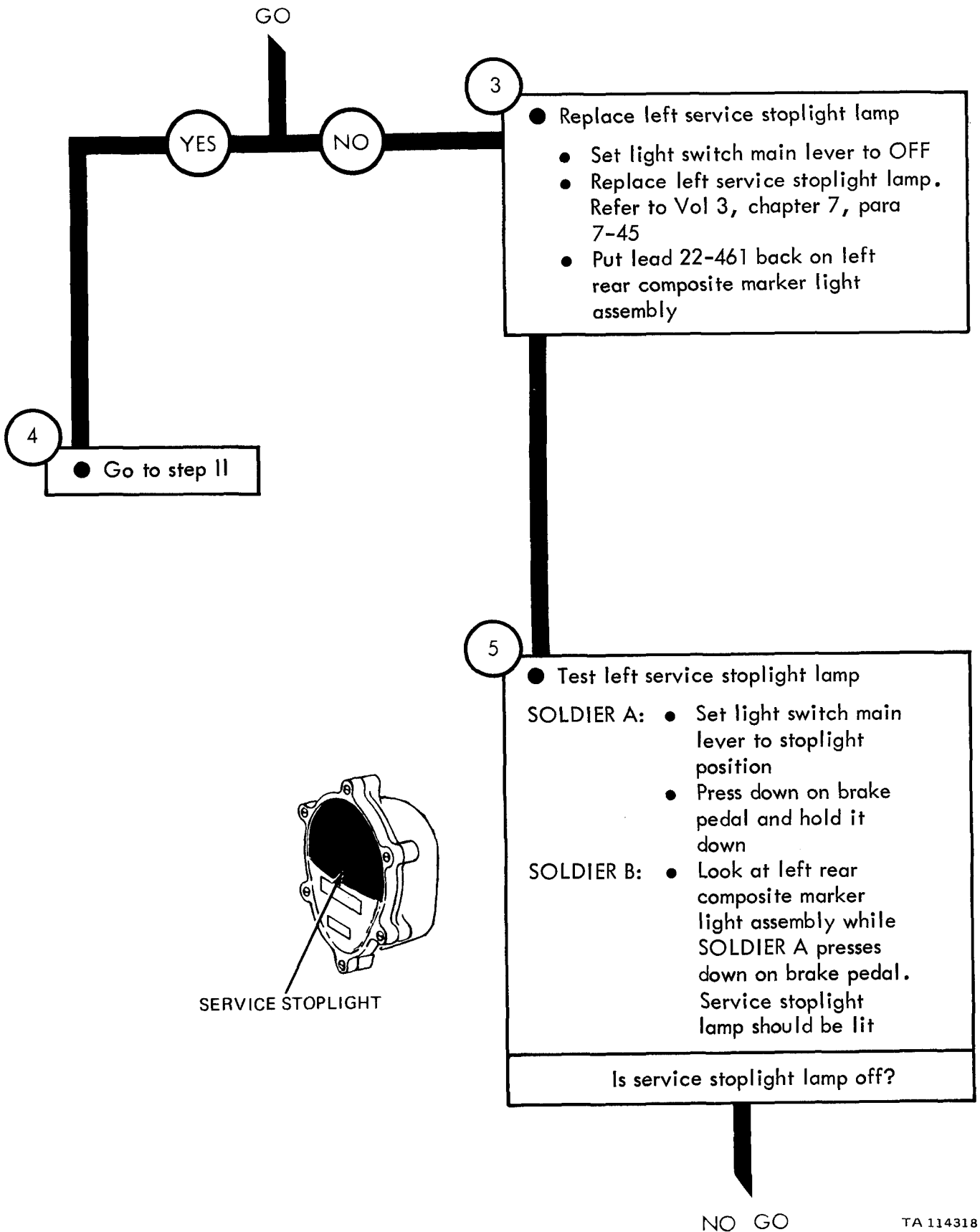
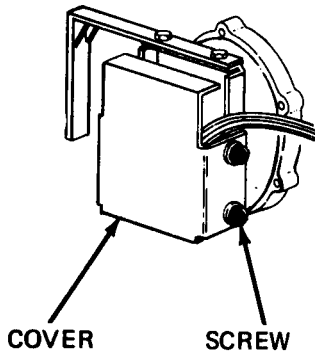
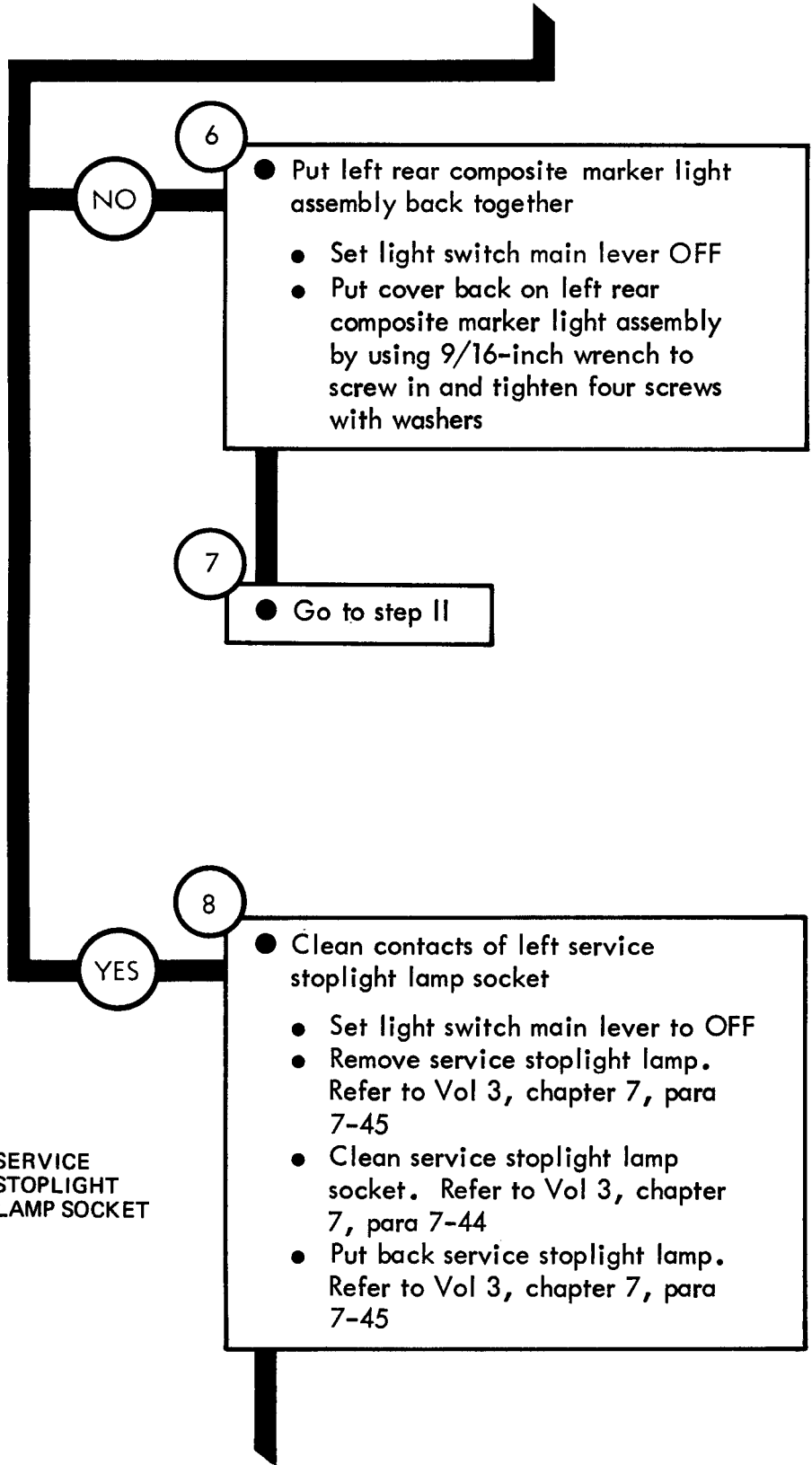

Figure 25-12 (Sheet 3 of 15)



NO GO



6

- Put left rear composite marker light assembly back together
- Set light switch main lever OFF
- Put cover back on left rear composite marker light assembly by using 9/16-inch wrench to screw in and tighten four screws with washers

7

- Go to step II

8

- Clean contacts of left service stoplight lamp socket
- Set light switch main lever to OFF
- Remove service stoplight lamp. Refer to Vol 3, chapter 7, para 7-45
- Clean service stoplight lamp socket. Refer to Vol 3, chapter 7, para 7-44
- Put back service stoplight lamp. Refer to Vol 3, chapter 7, para 7-45

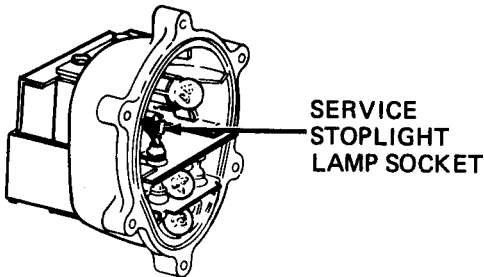

NO GO

Figure 25-12 (Sheet 4 of 15)

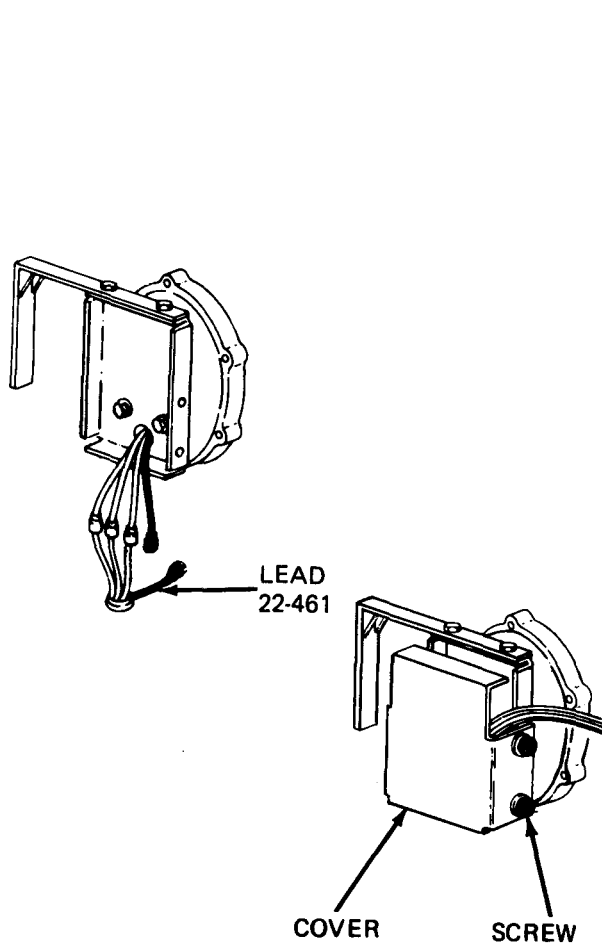

9

- Clean contacts of left service stoplight lamp connectors
 - Take off lead 22-461
 - Clean lead 22-461 contacts. Refer to Vol 3, chapter 7, para 7-46
 - Push lead 22-461 into connector
 - Put cover back on left rear composite marker light assembly by using 9/16-inch wrench to screw in and tighten four screws with washers

10

● Go to step II

From steps 4, 7 and 10

11

● Check for +24 volts DC at right service stoplight

SOLDIER B: ● Using 9/16-inch wrench, unscrew and take off four screws with washers from right rear composite marker assembly

- Take off cover
- Take off lead 22-460

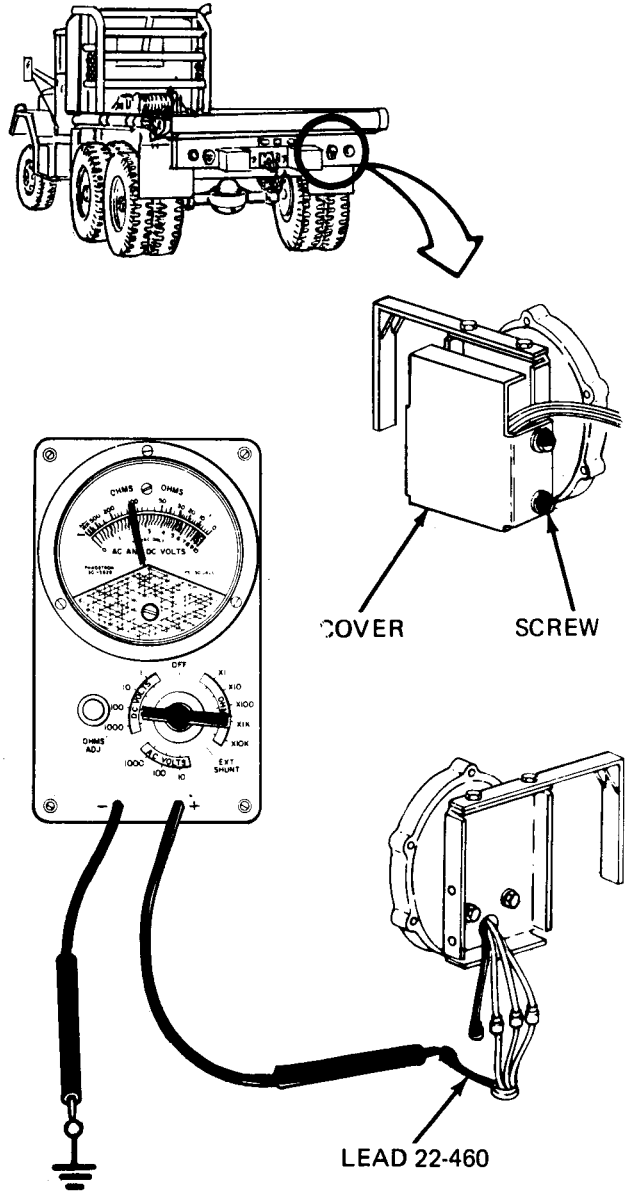

SOLDIER A: ● Set light switch main lever to STOPLIGHT

SOLDIER B: ● Put multimeter - lead on a good ground. Put multimeter + lead on lead 22-460

SOLDIER A: ● Step down on brake pedal and hold

SOLDIER B: ● Read multimeter while Soldier A presses down on brake pedal. Multimeter should measure +24 volts DC

Does multimeter measure less than +24 volts DC?



12

● Replace right service stoplight lamp

- Set light switch main lever to OFF
- Replace right service stoplight lamp. Refer to Vol 3, chapter 7, para 7-45
- Put back lead 22-460 at right rear composite marker assembly

13

● Go to step 18

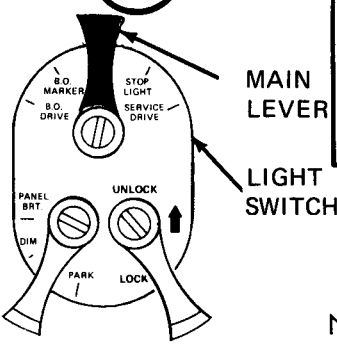

NO GO

Figure 25-12 (Sheet 6 of 15)



NO GO

14

- Test right service stoplight lamp
- SOLDIER A:
 - Set light switch main lever to STOPLIGHT
 - Press down on brake pedal and hold it down
- SOLDIER B:
 - Look at right rear composite marker light assembly while Soldier A steps down on brake pedal. Service stoplight lamp should be lit

Is service stoplight lamp off?

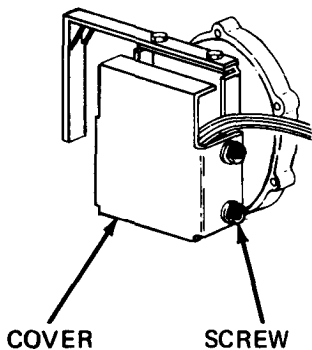

15

- Troubleshooting completed
- Put cover back on right rear composite marker light assembly by using 9/16-inch wrench to screw in and tighten four screws with washers

NO

16

- Clean contacts of right service stoplight lamp socket
- Set light switch main lever to OFF
- Remove service stoplight lamp. Refer to Vol 3, chapter 7, para 7-45
- Clean service stoplight lamp socket. Refer to Vol 3, chapter 7, para 7-45
- Put back service stoplight lamp. Refer to Vol 3, chapter 7, para 7-45

YES

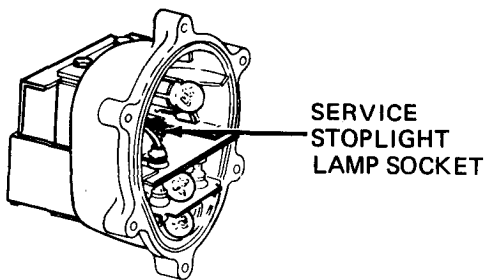

NO GO

TA 114322

Figure 25-12 (Sheet 7 of 15)

From step 13

NO GO

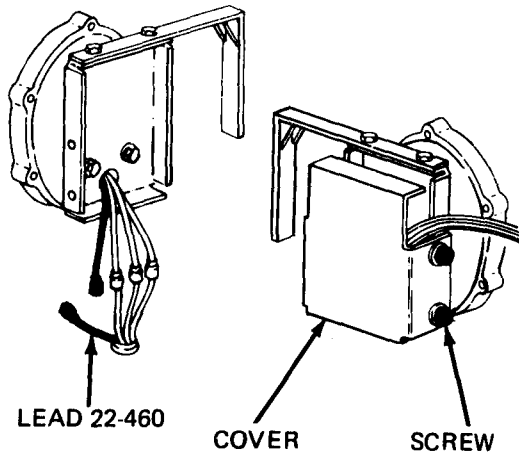

17

- Clean contacts of right service stoplight lamp connectors
 - Take off lead 22-460
 - Clean lead 22-460 contacts. Refer to Vol 3, chapter 7, para 7-44
 - Push lead 22-460 into connector
 - Put cover back on right rear composite marker light assembly by using 9/16-inch wrench to screw in and tighten four screws with washers

18

- Check voltage to front harness receptacle

SOLDIER B:

- Unscrew and take off rear harness receptacle
- Put multimeter - lead on a good ground
- Put multimeter + lead on contacts C and G of front harness receptacle

SOLDIER A:

- Step on brake pedal and hold it down

SOLDIER B:

- Read multimeter for +24 volts DC at both contacts C then G while Soldier A presses down on brake pedal

Does multimeter measure less than +24 volts DC for both tests?

GO

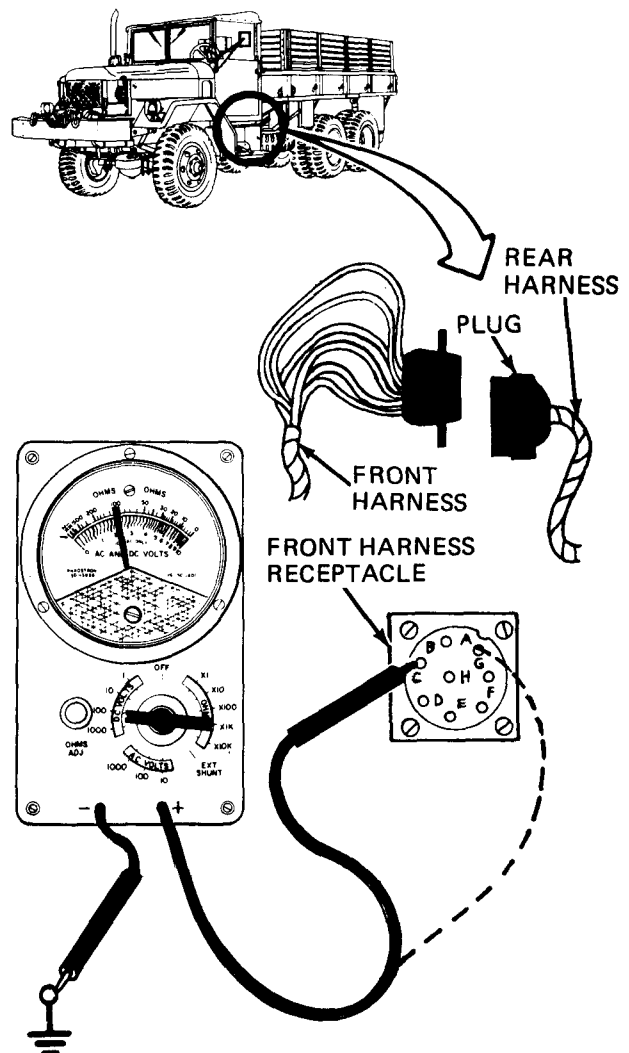

TA 114323

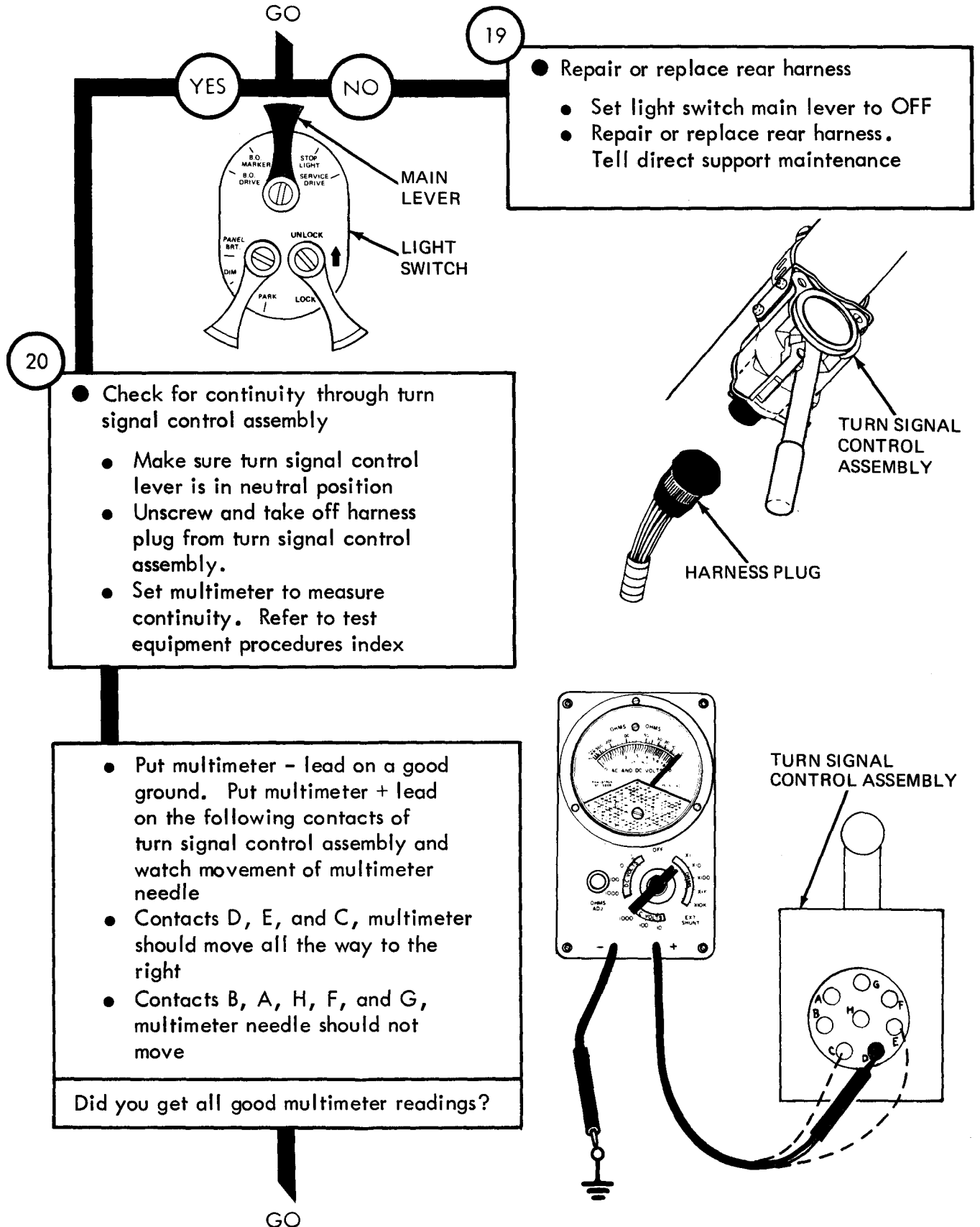

- 19
- Repair or replace rear harness
 - Set light switch main lever to OFF
 - Repair or replace rear harness. Tell direct support maintenance

- 20
- Check for continuity through turn signal control assembly
 - Make sure turn signal control lever is in neutral position
 - Unscrew and take off harness plug from turn signal control assembly.
 - Set multimeter to measure continuity. Refer to test equipment procedures index

- Put multimeter - lead on a good ground. Put multimeter + lead on the following contacts of turn signal control assembly and watch movement of multimeter needle
- Contacts D, E, and C, multimeter should move all the way to the right
- Contacts B, A, H, F, and G, multimeter needle should not move

Did you get all good multimeter readings?

GO

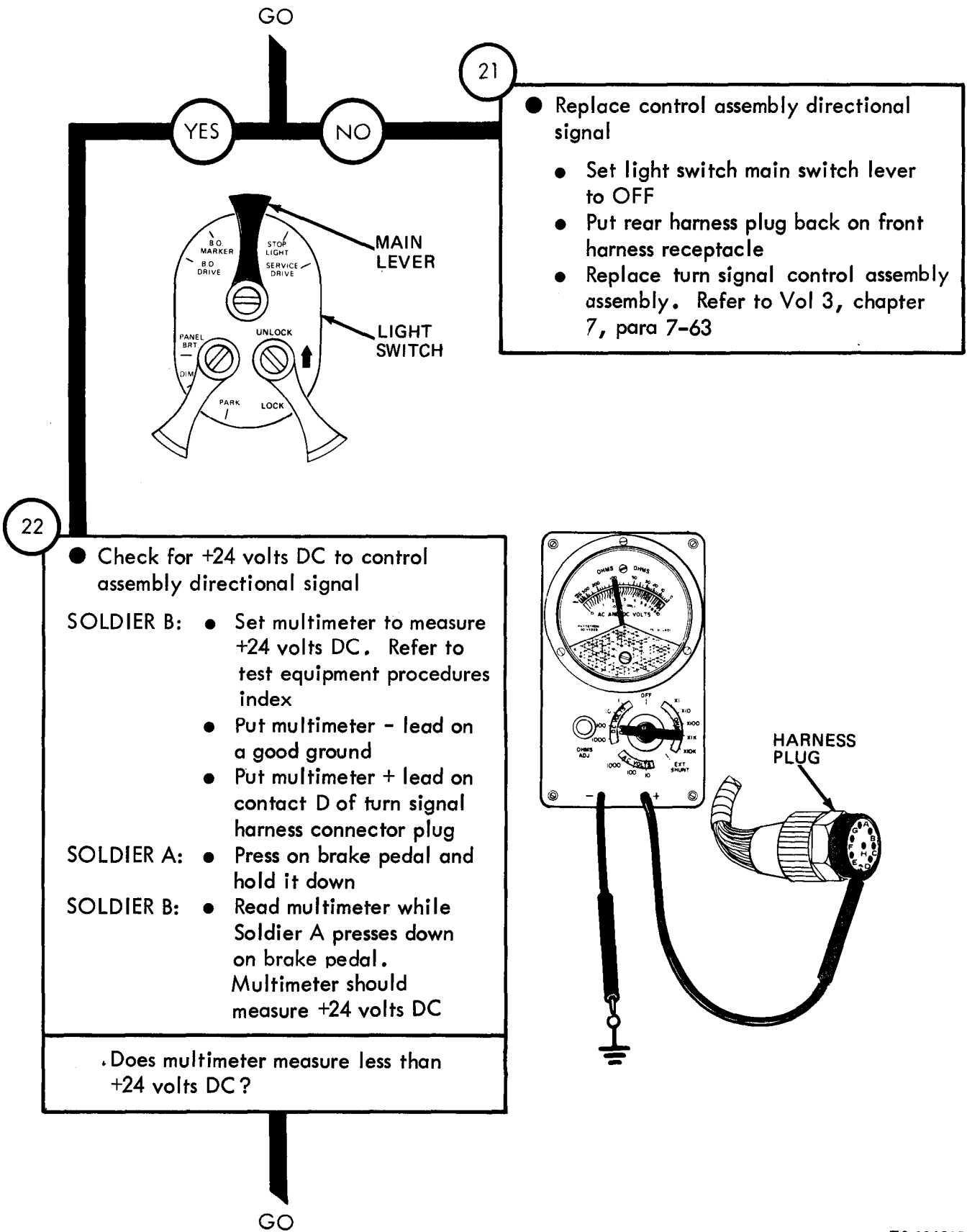

21

- Replace control assembly directional signal
 - Set light switch main switch lever to OFF
 - Put rear harness plug back on front harness receptacle
 - Replace turn signal control assembly. Refer to Vol 3, chapter 7, para 7-63

22

- Check for +24 volts DC to control assembly directional signal
- SOLDIER B:
- Set multimeter to measure +24 volts DC. Refer to test equipment procedures index
 - Put multimeter - lead on a good ground
 - Put multimeter + lead on contact D of turn signal harness connector plug
- SOLDIER A:
- Press on brake pedal and hold it down
- SOLDIER B:
- Read multimeter while Soldier A presses down on brake pedal. Multimeter should measure +24 volts DC
- Does multimeter measure less than +24 volts DC?

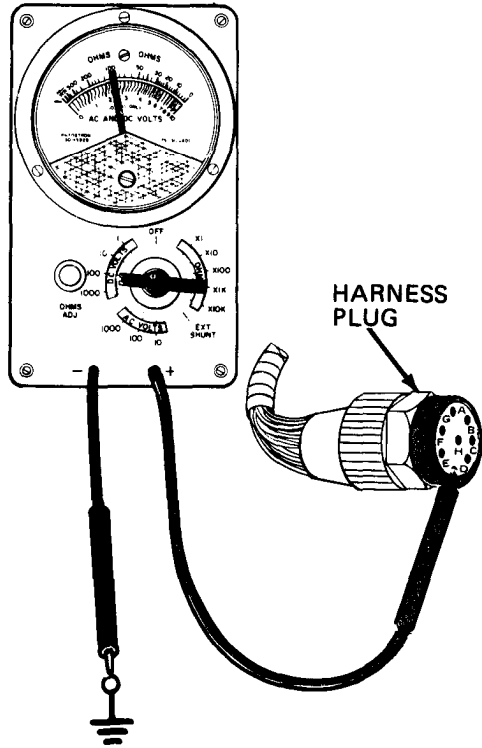

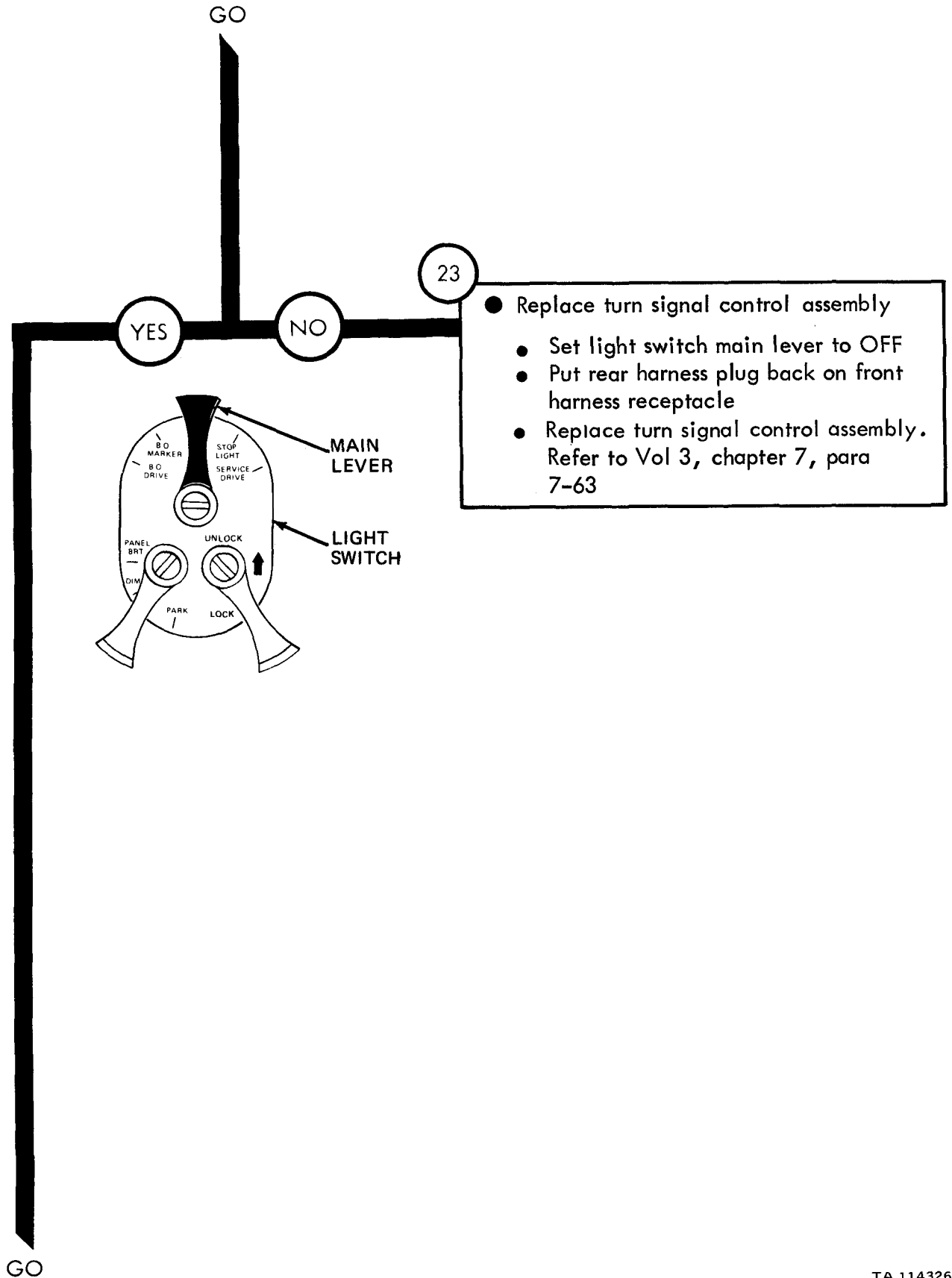

Figure 25-12 (Sheet II of 15)

GO

24

- Check stoplight switch for +24 volts DC

SOLDIER A ● Set light switch main lever to OFF

- Using 5/8-inch wrench, remove shield from under air hydraulic cylinder (all trucks except M48, M275 and M275A)

SOLDIER B ● Take off lead 75 connector plug from stoplight switch. Refer to Vol 3, chapter 7, para 7-67

SOLDIER A ● Set light switch main lever to STOPLIGHT

- Step down on brake pedal and hold it down

SOLDIER B ● While Soldier A steps down on brake pedal put multimeter - lead on good ground. Put multimeter + lead on each lead 75 and see which reads +24 volts DC

- Put jumper wire from lead 75 that gave +24 volts DC reading to either stoplight switch contact
- Put multimeter - lead on good ground
- With Soldier A still pressing down on brake pedal read multimeter. Multimeter should measure +24 volts DC

Does multimeter measure +24 volts DC?

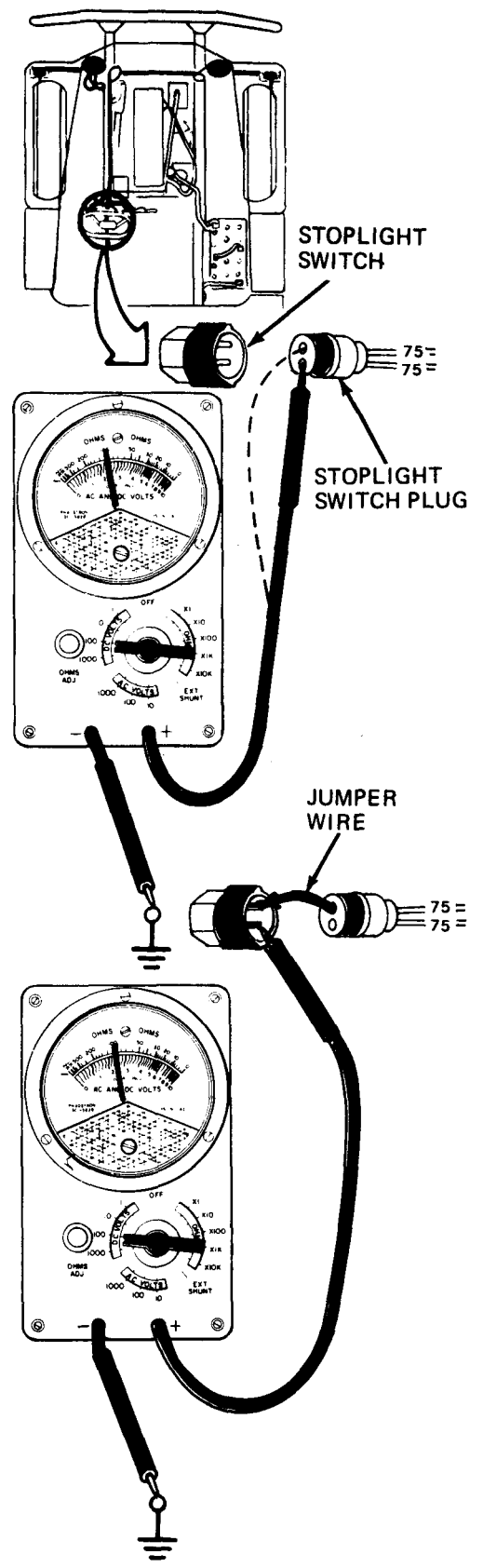

GO

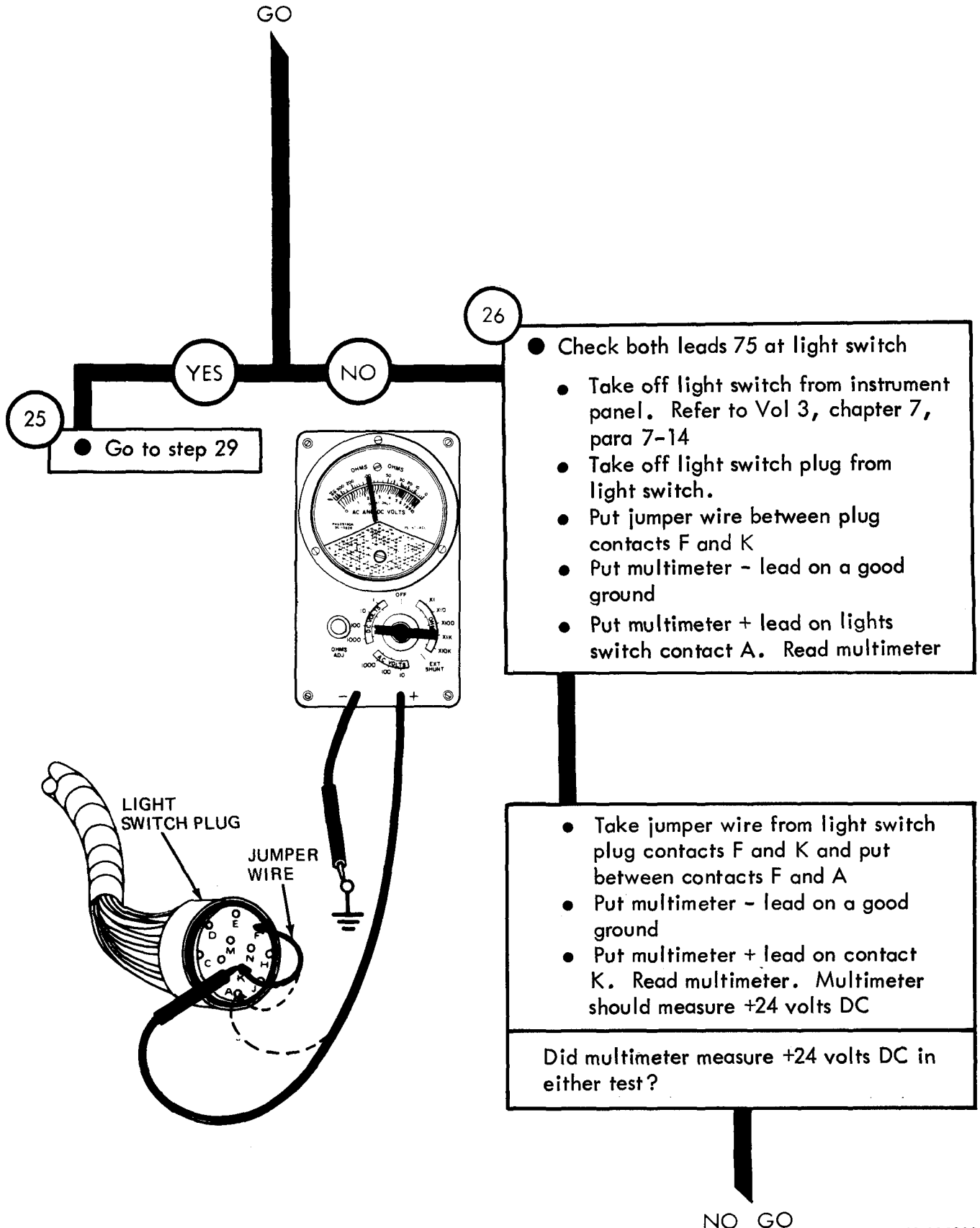
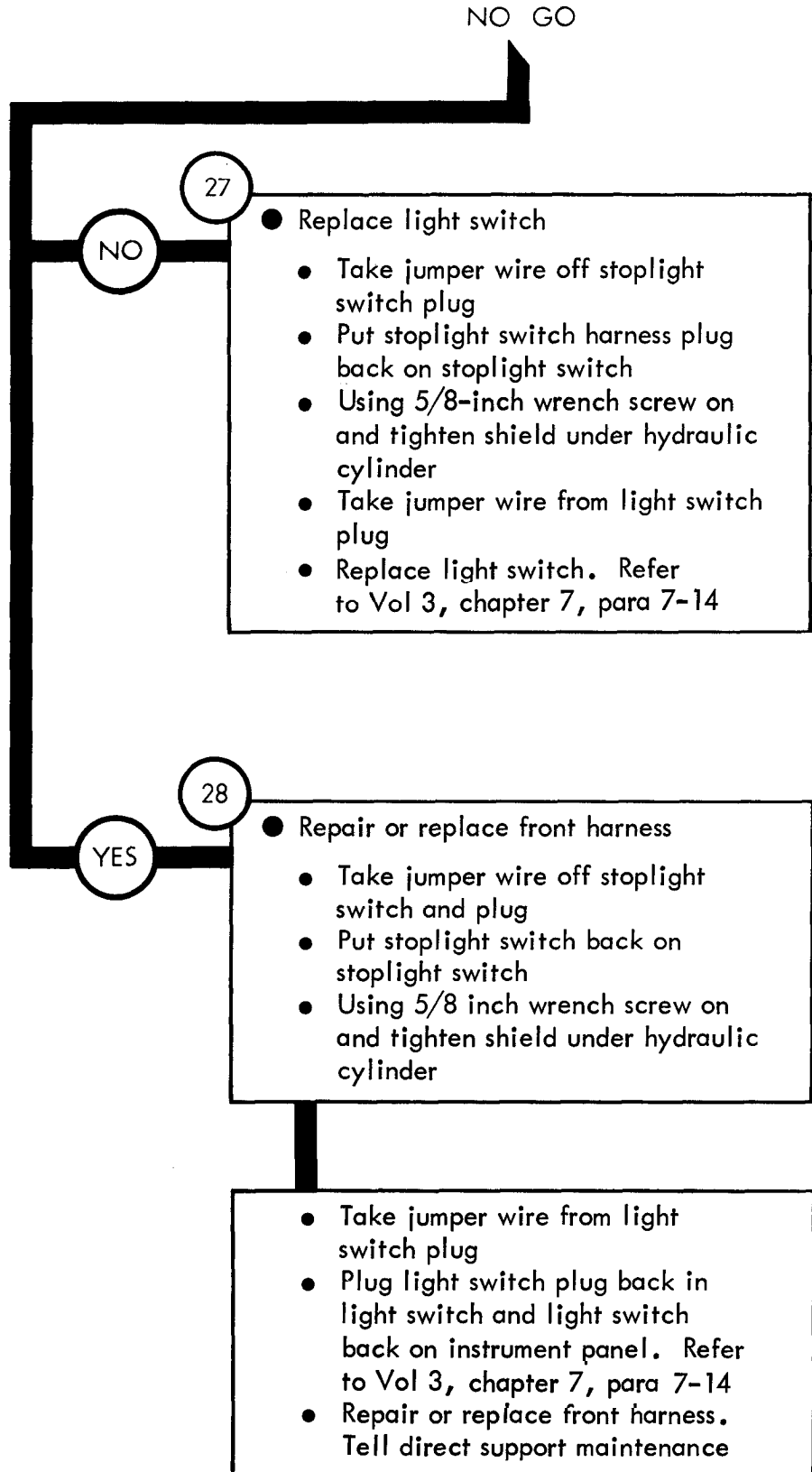

Figure 25-12 (Sheet 13 of 15)



TA 114329

Figure 25-12 (Sheet 14 of 15)

From step 25

29

- Check for +24 volts DC through stoplight switch
 - Put jumper wire from lead 75 that gave +24 volts DC reading to either stoplight switch contact
 - Put multimeter + lead on other contact of stoplight switch
 - Put multimeter - lead on good ground
 - With Soldier A still pressing down on brake pedal read multimeter. Multimeter should measure +24 volts DC

Does multimeter measure +24 volts DC?

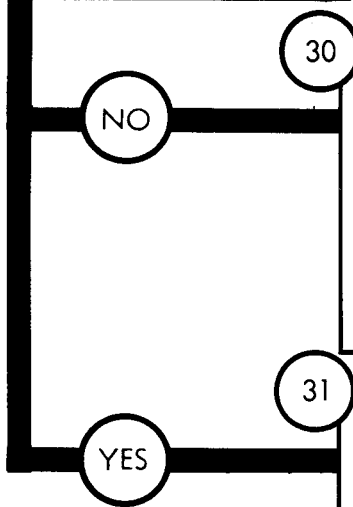
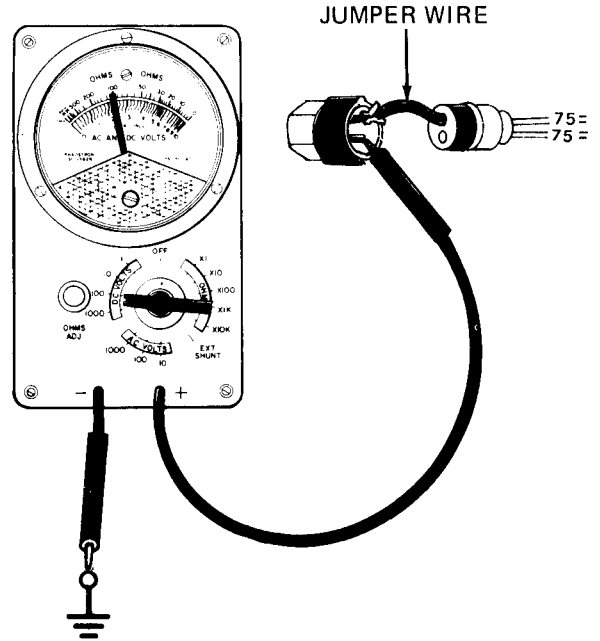

30

- Replace stoplight switch
 - Set light switch main lever to OFF
 - Put rear harness plug back in front harness receptacle
 - Replace stoplight switch. Refer to Vol 3, chapter 7, para 7-67 or 7-68

31

- Repair or replace front harness
 - SOLDIER A ● Set light switch main switch lever to OFF
 - SOLDIER B ● Take off jumper wire from lead 75 and contact of stoplight switch
 - Put stoplight switch harness plug back on stoplight switch
 - Using 5/8-inch wrench screw on and tighten shield under hydraulic cylinder
 - Repair or replace front harness. Tell direct support maintenance

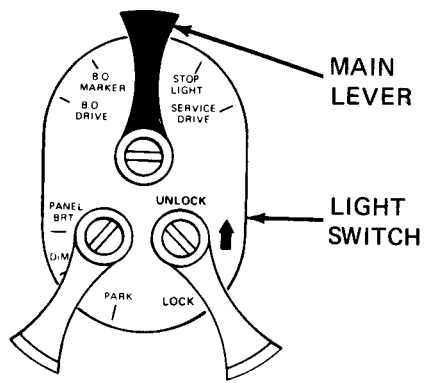

Figure 25-12 (Sheet 15 of 15)

Symptom

13

ONE BLACKOUT STOPLIGHT DOES NOT LIGHT,
OTHER BLACKOUT STOPLIGHT LIGHTS

NOTE

Two soldiers are needed to troubleshoot a blackout stoplight. Soldier A sits in the cab and operates the controls. Soldier B makes voltage checks with the multimeter

When checking voltage +24 volts DC means a range of +23 volts DC to +26 volts DC

1

- Park truck
 - Refer to TM 9-2320-209-10

2

- Check for +24 volts DC at bad blackout stoplight
- SOLDIER B:
- Using 9/16-inch wrench, unscrew and take off four screws with washers from rear composite marker assembly
 - Take off cover
 - Take off lead 23

GO

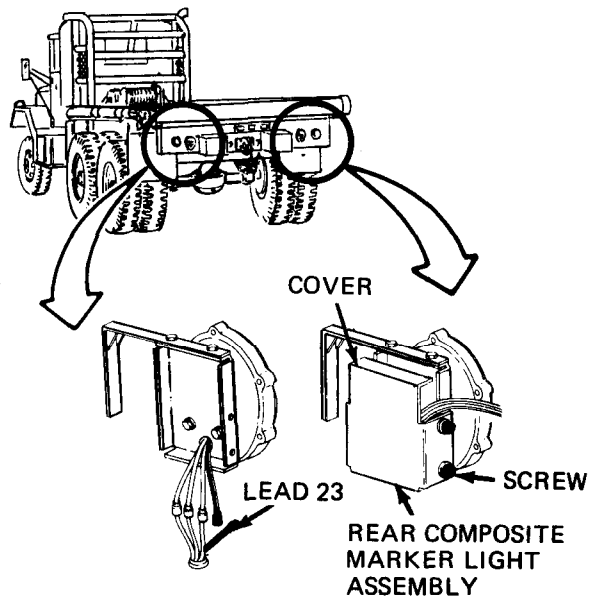

TA 114331

Figure 25-13 (Sheet 1 of 5)

GO

- SOLDIER A:**
- Set light switch main lever to B.O. MARKER
 - Make sure turn signal control handle is in neutral position
- SOLDIER B:**
- Set multimeter to read +24 volts DC. Refer to test equipment procedures index

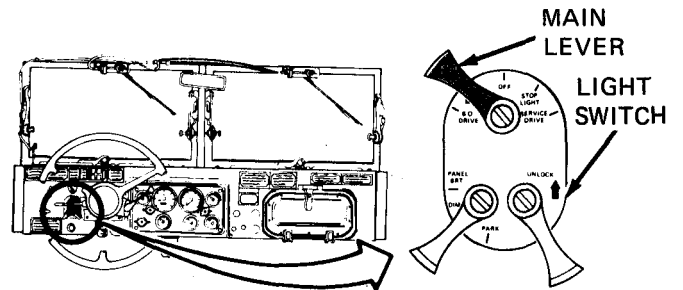
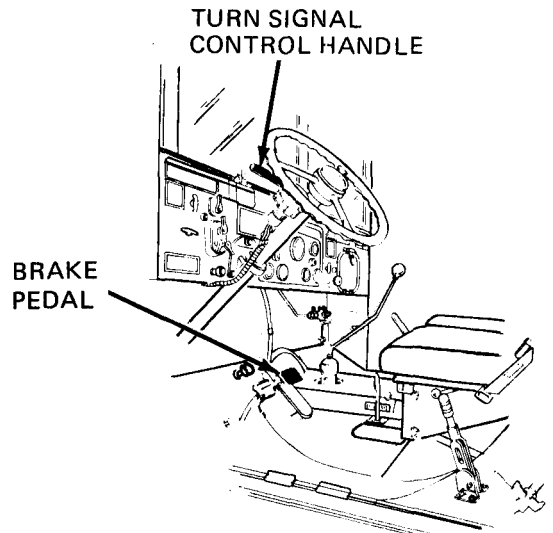

- SOLDIER B:**
- Put multimeter + lead on lead 23 and - lead on a good ground
- SOLDIER A:**
- Press down on brake pedal and hold it down
- SOLDIER B:**
- Read multimeter while Soldier A presses down on brake pedal. Multimeter should measure +24 volts DC

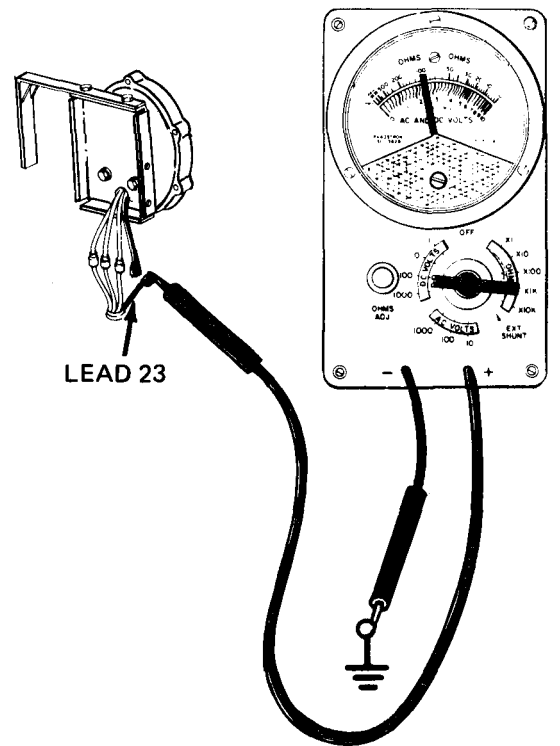

Does multimeter measure less than +24 volts DC?

GO

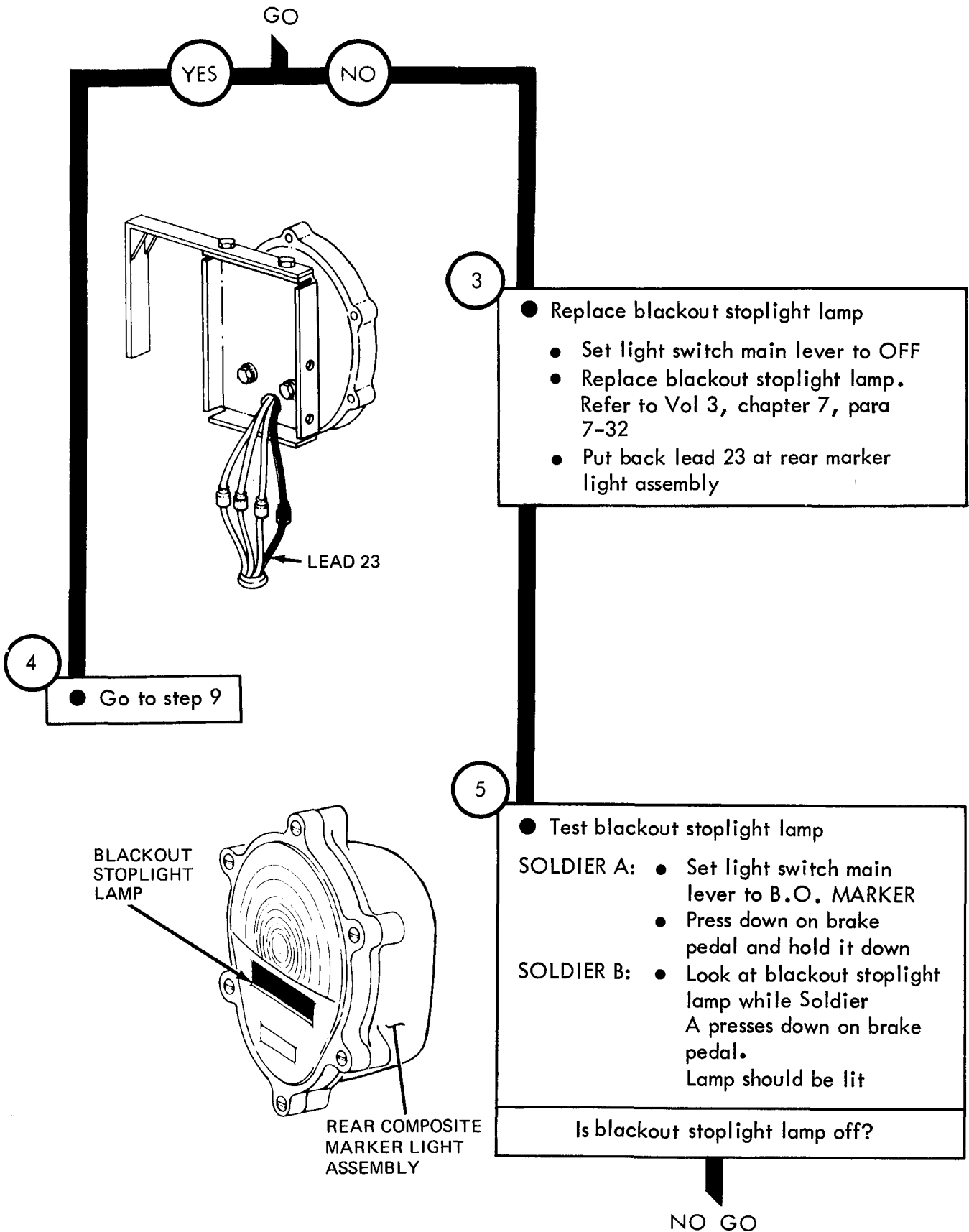

NO GO

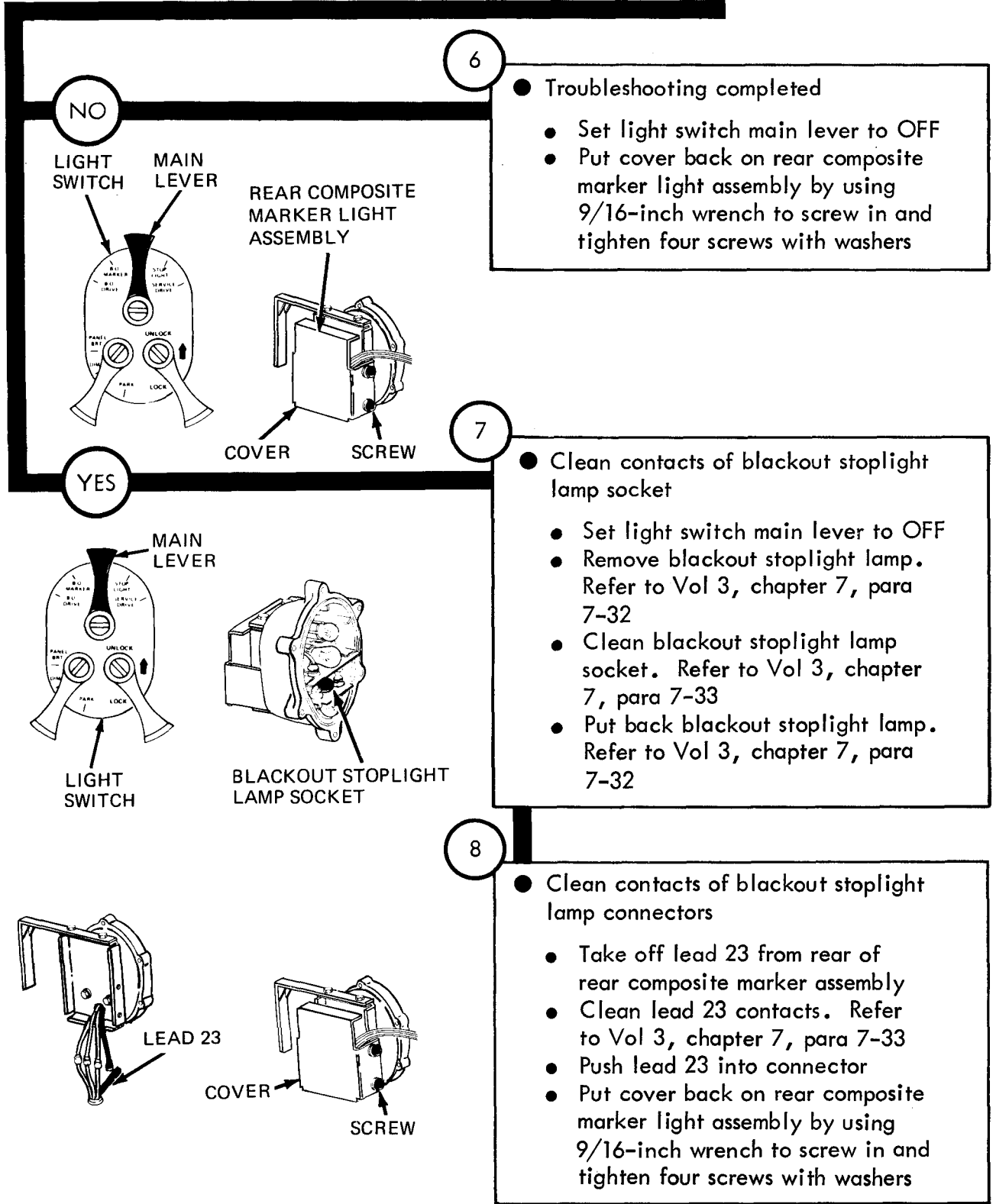

6

- Troubleshooting completed
- Set light switch main lever to OFF
- Put cover back on rear composite marker light assembly by using 9/16-inch wrench to screw in and tighten four screws with washers

7

- Clean contacts of blackout stoplight lamp socket
- Set light switch main lever to OFF
- Remove blackout stoplight lamp. Refer to Vol 3, chapter 7, para 7-32
- Clean blackout stoplight lamp socket. Refer to Vol 3, chapter 7, para 7-33
- Put back blackout stoplight lamp. Refer to Vol 3, chapter 7, para 7-32

8

- Clean contacts of blackout stoplight lamp connectors
- Take off lead 23 from rear of rear composite marker assembly
- Clean lead 23 contacts. Refer to Vol 3, chapter 7, para 7-33
- Push lead 23 into connector
- Put cover back on rear composite marker light assembly by using 9/16-inch wrench to screw in and tighten four screws with washers

Figure 25-13 (Sheet 4 of 5)

From step 4



9

- Trouble is in rear harness. Repair or replace rear harness
- Set light switch main lever to OFF
- Repair or replace rear harness. Tell direct support maintenance

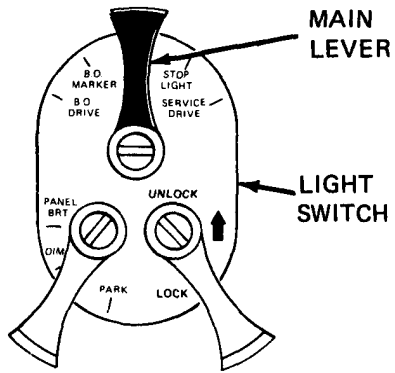

Figure 25-13 (Sheet 5 of 5)

Symptom

14

BOTH BLACKOUT STOPLIGHTS DO NOT LIGHT, OTHER TRUCK RUNNING LIGHTS LIGHT

NOTE

Two soldiers are needed to troubleshoot the blackout stoplights. Soldier A sits in the cab and operates the controls. Soldier B makes voltage checks with the multimeter

When checking voltage, +24 volts DC means a range of +23 to +26 volts DC

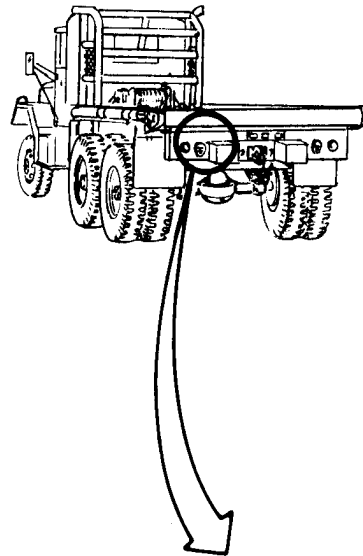

1

- Park truck
- Refer to TM 9-2320-209-10

2

- Check for +24 volts DC at left blackout stoplight
- SOLDIER B: ● Using 9/16-inch wrench, unscrew four screws with washers from left rear composite marker assembly
- Take off cover
 - Take off lead 23 from left rear composite marker assembly

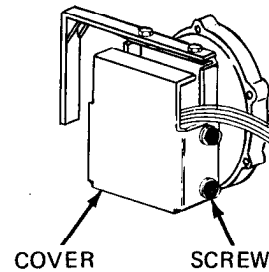

GO

Figure 25-14 (Sheet 1 of 24)

GO

SOLDIER A:

- Set light switch main lever to B. O. MARKER position
- Make sure turn signal control handle is in neutral position

SOLDIER B:

- Set multimeter to measure +24 volts DC. Refer to test equipment procedures index

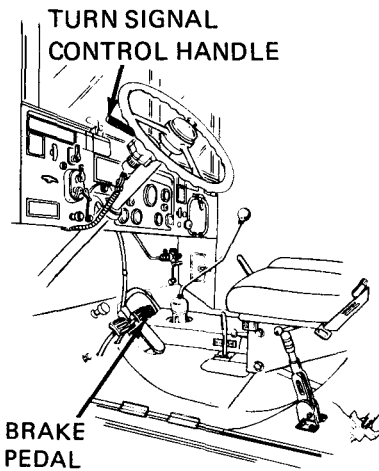
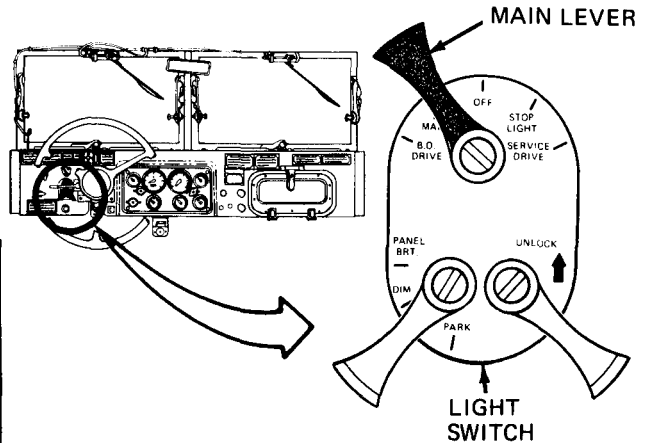

SOLDIER B:

- Put multimeter + lead on lead 23 and - lead on a good ground

SOLDIER A:

- Press down on brake pedal and hold it down

SOLDIER B:

- Read multimeter while Soldier A presses down on brake pedal. Multimeter should measure +24 volts DC

Does multimeter measure less than +24 volts DC?

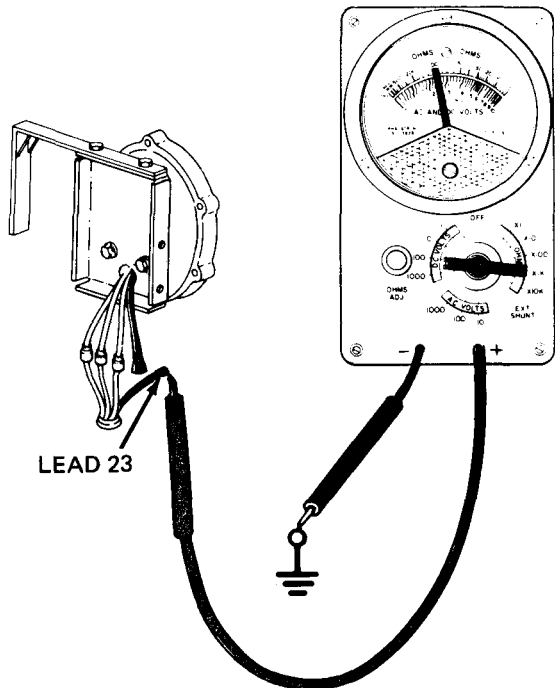

GO

Figure 25-14 (Sheet 2 of 24)

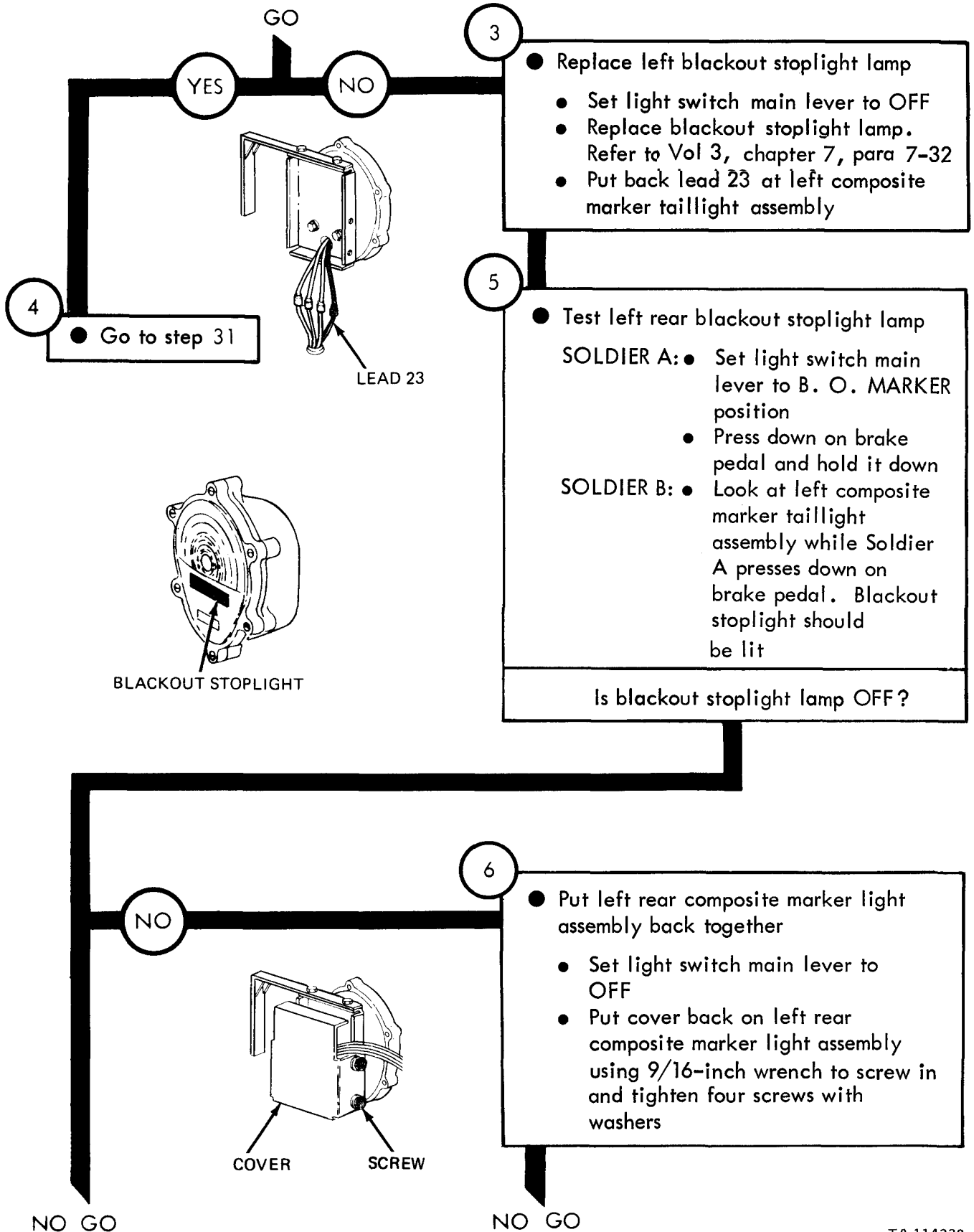

3

- Replace left blackout stoplight lamp
 - Set light switch main lever to OFF
 - Replace blackout stoplight lamp. Refer to Vol 3, chapter 7, para 7-32
 - Put back lead 23 at left composite marker taillight assembly

4

- Go to step 31

5

- Test left rear blackout stoplight lamp
 - SOLDIER A:
 - Set light switch main lever to B. O. MARKER position
 - Press down on brake pedal and hold it down
 - SOLDIER B:
 - Look at left composite marker taillight assembly while Soldier A presses down on brake pedal. Blackout stoplight should be lit

Is blackout stoplight lamp OFF?

NO

6

- Put left rear composite marker light assembly back together
 - Set light switch main lever to OFF
 - Put cover back on left rear composite marker light assembly using 9/16-inch wrench to screw in and tighten four screws with washers

NO GO

NO GO

TA 114338

Figure 25-14 (Sheet 3 of 24)

NO GO

NO GO

7

● Go to step 10

YES

8

- Clean contacts of left blackout stoplight lamp socket
 - Set light switch main lever to OFF
 - Remove blackout stoplight lamp. Refer to Vol 3, chapter 7, para 7-32
 - Clean blackout stoplight lamp socket. Refer to Vol 3, chapter 7, para 7-33
 - Replace blackout stoplight lamp. Refer to Vol 3, chapter 7, para 7-32

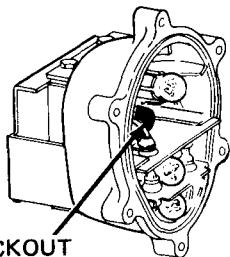

BLACKOUT
STOPLIGHT
LAMP SOCKET

9

- Clean contacts of left blackout stoplight lamp connectors
 - Take off lead 23 from rear of left rear composite marker assembly
 - Clean lead 23 contacts. Refer to Vol 3, chapter 7, para 7-33
 - Push lead 23 into connector
 - Put cover back on left rear composite marker light assembly by using 9/16-inch wrench to screw in and tighten four screws with washers

NO GO

TA 114339

Figure 25-14 (Sheet 4 of 24)

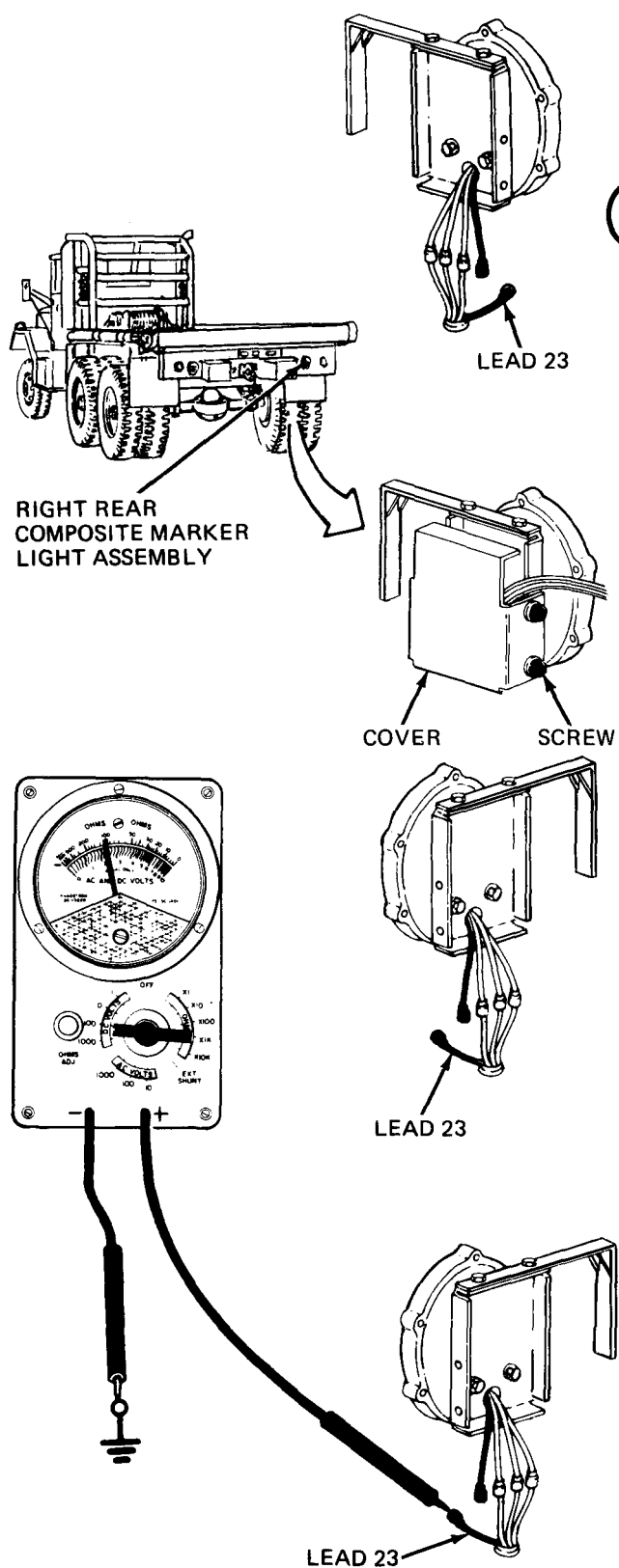

10

● Check for +24 volts at right blackout stoplight

SOLDIER B: ● Using 9/16-inch wrench, unscrew and take off four screws with washers from right rear composite marker assembly

● Take off cover

● Take off lead 23 from rear of right rear composite marker light assembly

SOLDIER A: ● Set light switch main lever to B. O. MARKER position

SOLDIER B: ● Put multimeter + lead on lead 23 and - lead on a good ground

SOLDIER A: ● Press down on brake pedal and hold it down

SOLDIER B: ● Read multimeter while Soldier A presses down on brake pedal. Multimeter should measure +24 volts DC

Does multimeter measure less than +24 volts DC?

NO GO

Figure 25-14 (Sheet 5 of 24)

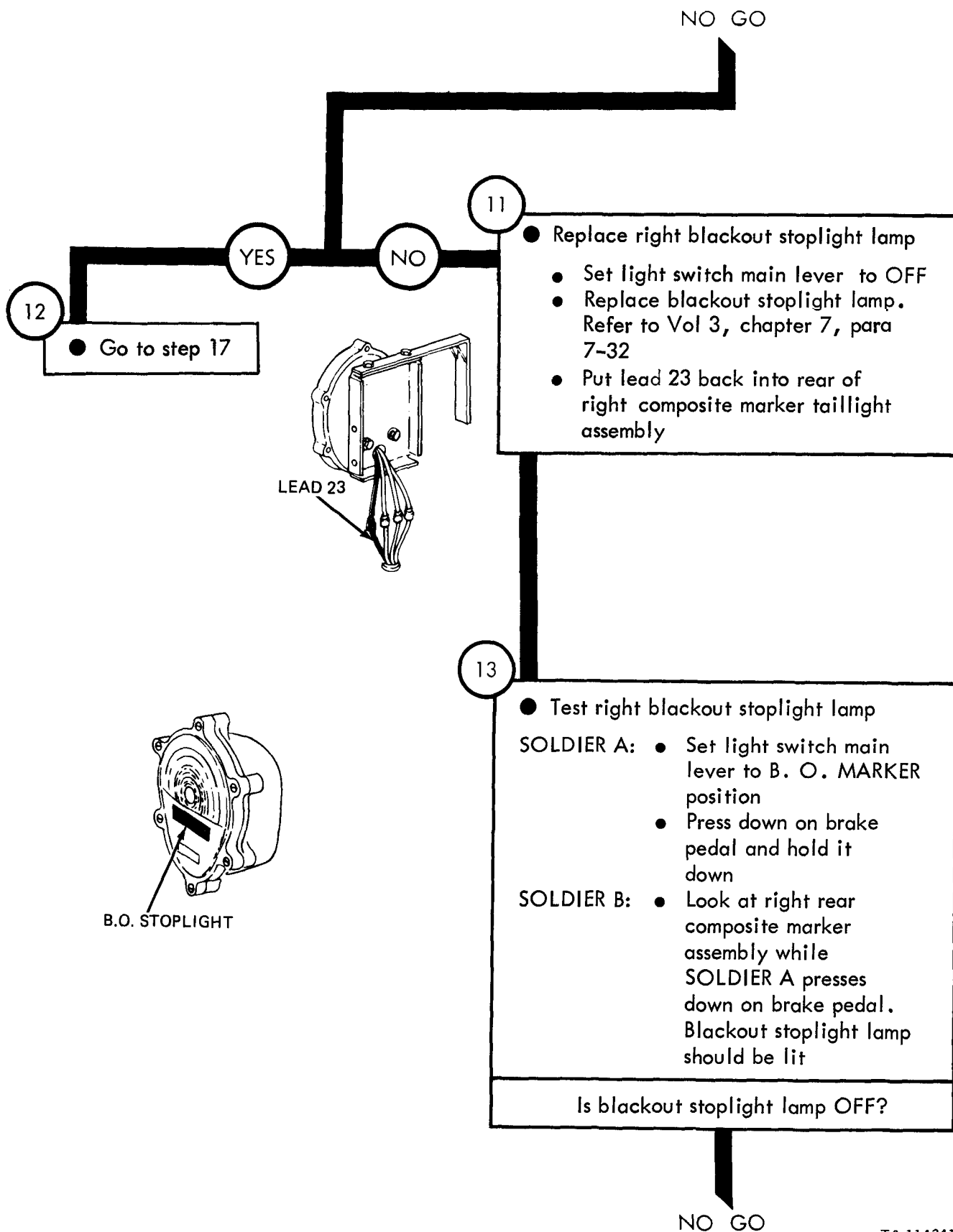

TA 114341

Figure 25-14 (Sheet 6 of 24)

NO GO

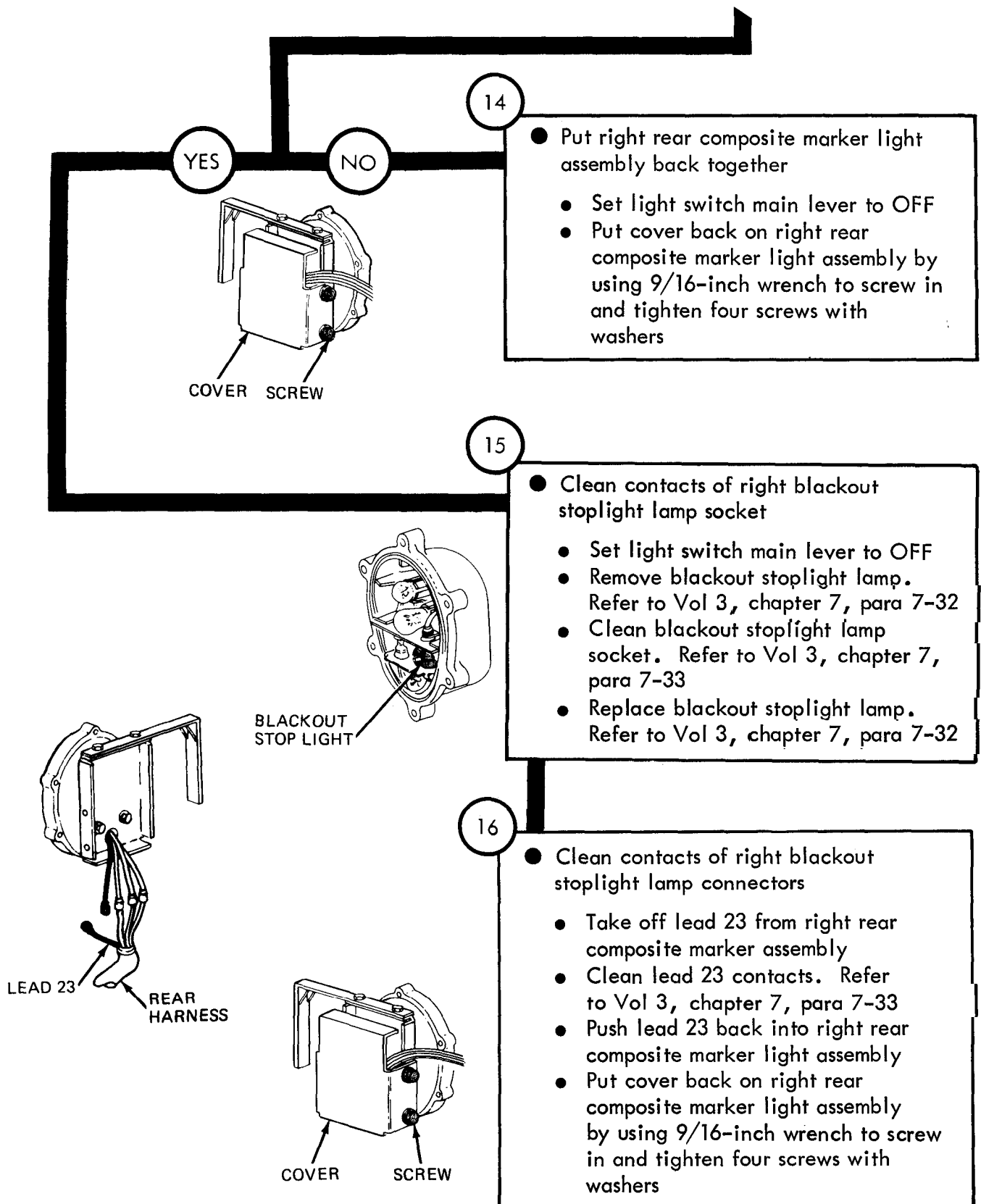

TA 114342

Figure 25-14 (Sheet 7 of 24)

From step 12

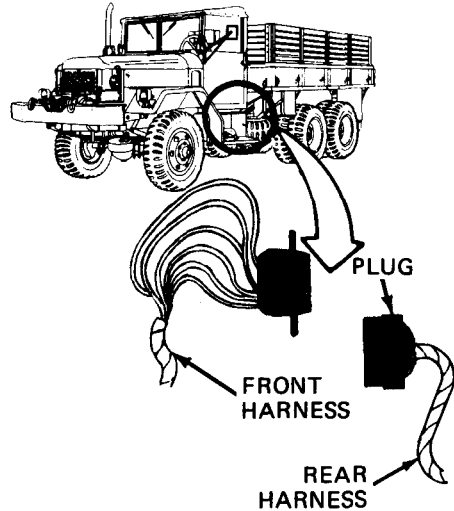

17

- Check voltage to front and rear harness connectors
- SOLDIER B: ● Unscrew and take off rear harness plug from front harness receptacle
- SOLDIER A: ● Step on brake pedal and hold it down
- SOLDIER B: ● Put multimeter - lead on a good ground. Put multimeter + lead on contact B of front harness receptacle
- Read multimeter for +24 volts DC while Soldier A presses on brake pedal

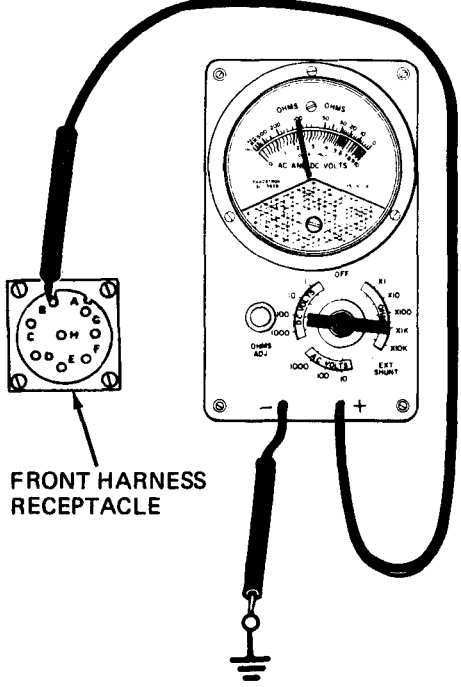

Does multimeter measure +24 volts DC?

YES NO

18

- Repair or replace front harness
- Set light switch main lever to OFF
- Repair or replace front harness. Tell direct support maintenance

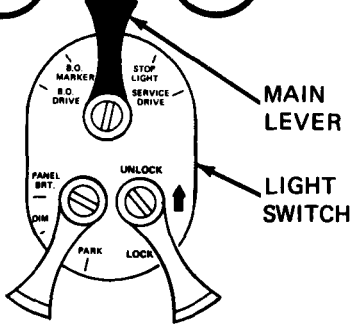

GO

TA 114343

Figure 25-14 (Sheet 8 of 24)

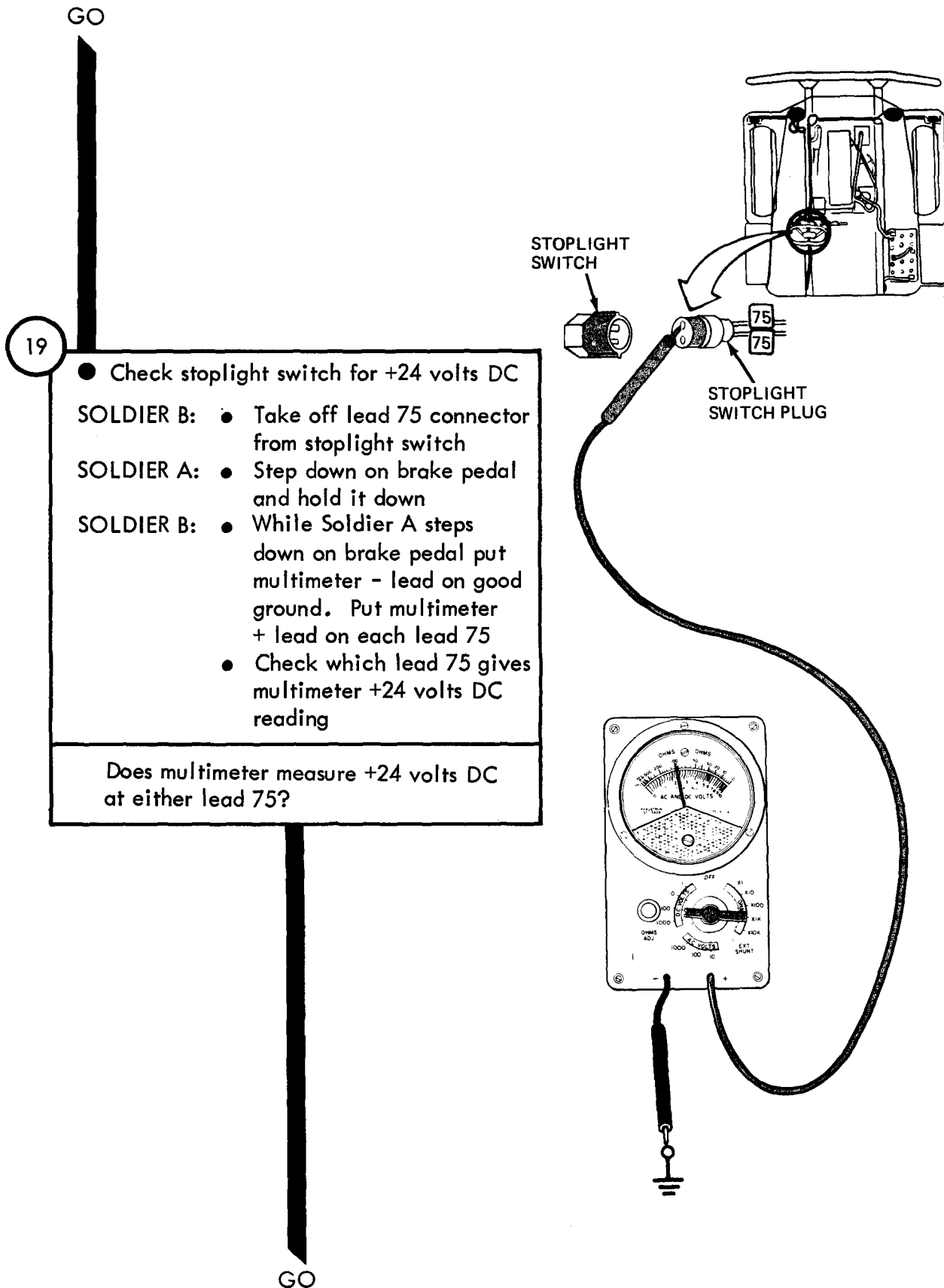

TA 114344

Figure 25-14 (Sheet 9 of 24)

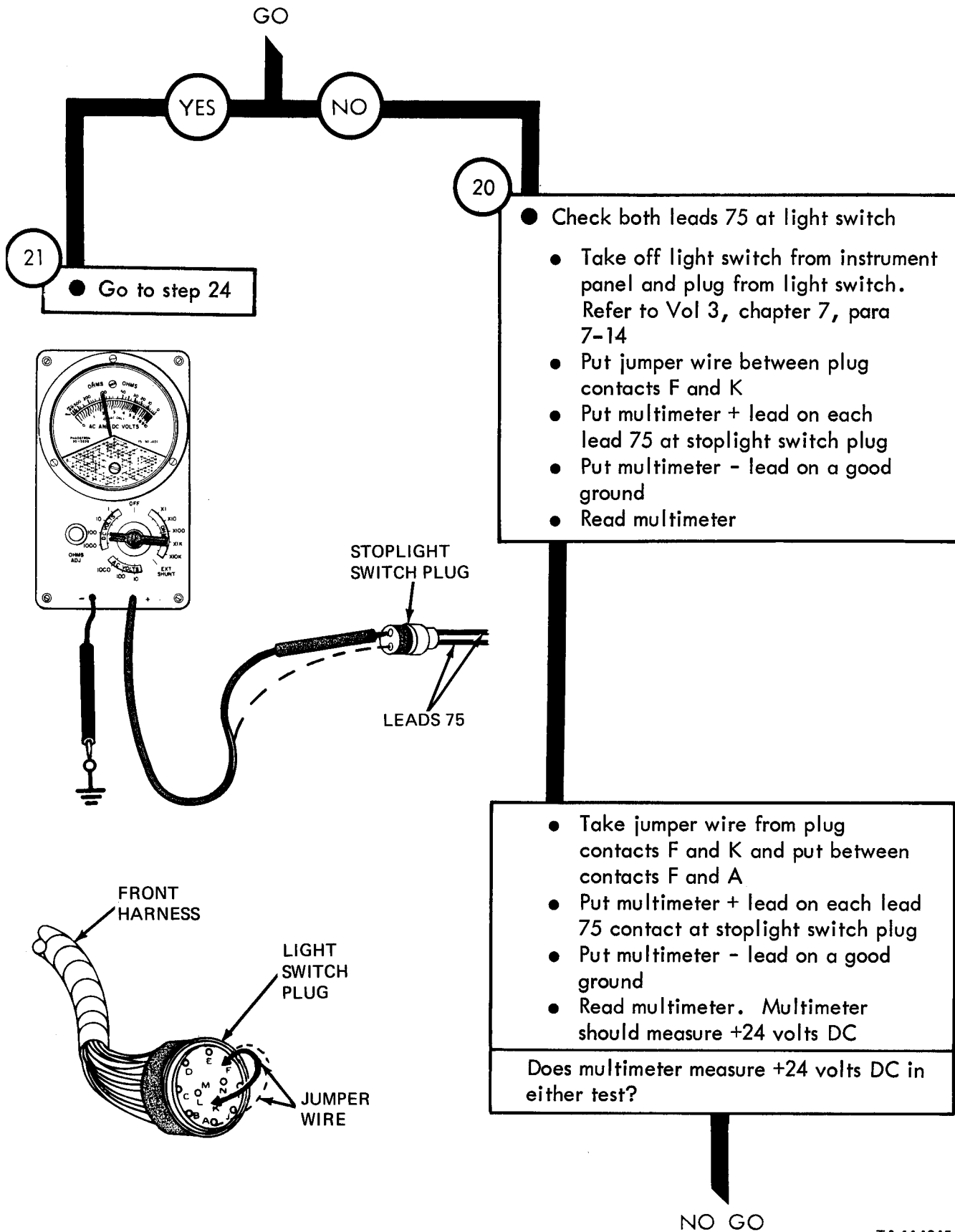

- Check both leads 75 at light switch
 - Take off light switch from instrument panel and plug from light switch. Refer to Vol 3, chapter 7, para 7-14
 - Put jumper wire between plug contacts F and K
 - Put multimeter + lead on each lead 75 at stoplight switch plug
 - Put multimeter - lead on a good ground
 - Read multimeter

- Take jumper wire from plug contacts F and K and put between contacts F and A
- Put multimeter + lead on each lead 75 contact at stoplight switch plug
- Put multimeter - lead on a good ground
- Read multimeter. Multimeter should measure +24 volts DC

Does multimeter measure +24 volts DC in either test?

NO GO

Figure 25-14 (Sheet 10 of 24)

NO GO

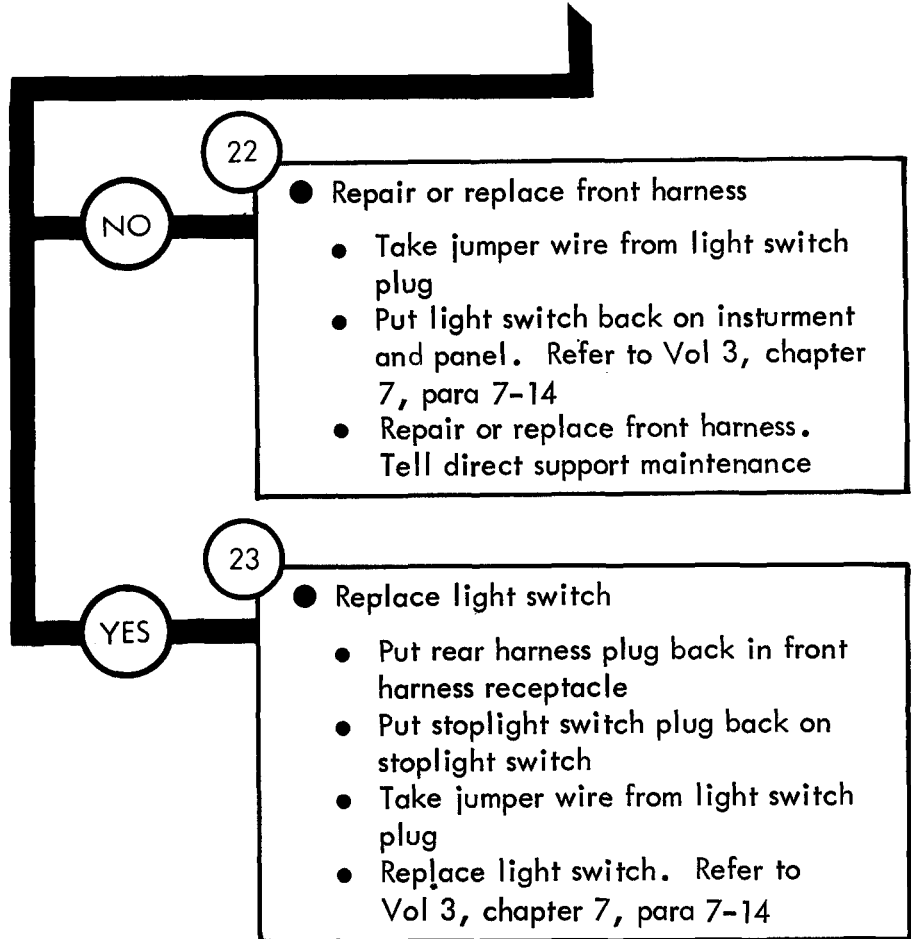

From step 21

24

- Check for +24 volts DC through stoplight switch
 - Put jumper wire from lead 75 that gave +24 volts DC reading to either stoplight switch connector
 - Put multimeter - lead on good ground and multimeter + lead on other connector of stoplight switch
 - With Soldier A still pressing down on brake pedal read multimeter. Multimeter should read +24 volts DC.

Does multimeter read +24 volts DC?

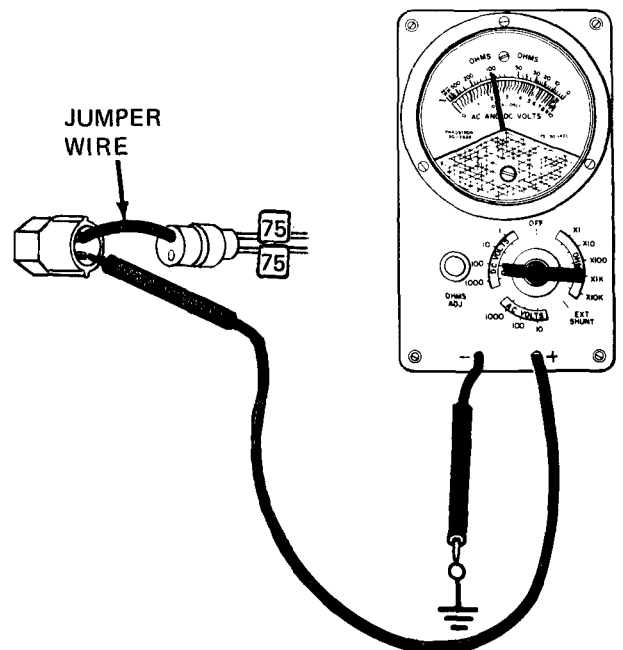

GO

TA 114346

Figure 25-14 (Sheet 11 of 24)

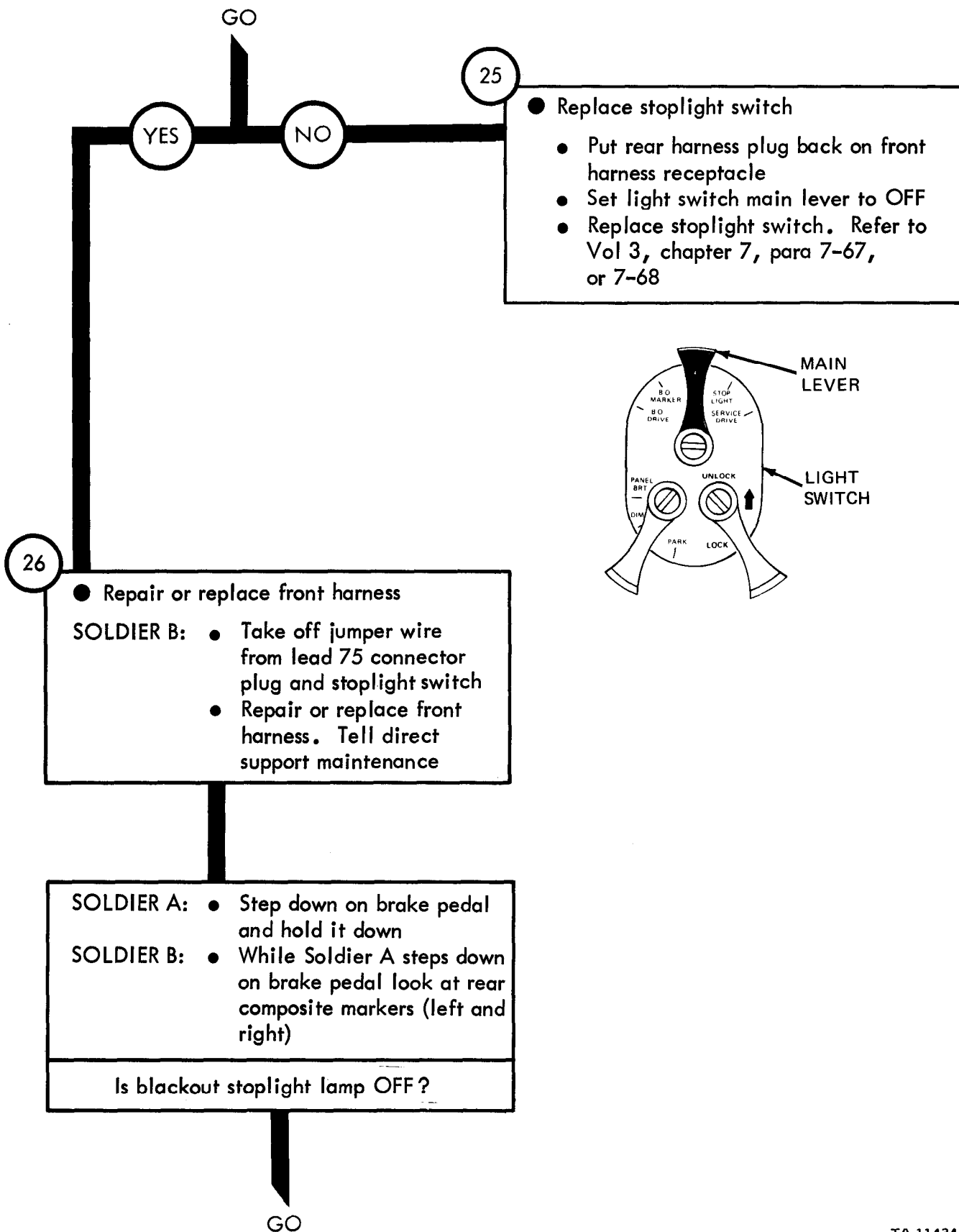

● **Replace stoplight switch**

- Put rear harness plug back on front harness receptacle
- Set light switch main lever to OFF
- Replace stoplight switch. Refer to Vol 3, chapter 7, para 7-67, or 7-68

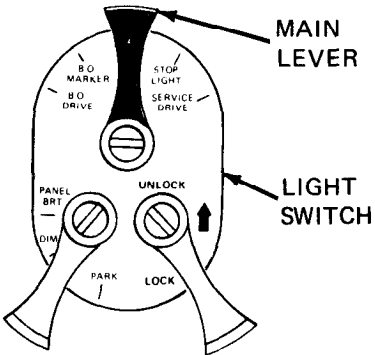

● **Repair or replace front harness**

SOLDIER B:

- Take off jumper wire from lead 75 connector plug and stoplight switch
- Repair or replace front harness. Tell direct support maintenance

SOLDIER A:

- Step down on brake pedal and hold it down

SOLDIER B:

- While Soldier A steps down on brake pedal look at rear composite markers (left and right)

Is blackout stoplight lamp OFF?

Figure 25-14 (Sheet 12 of 24)

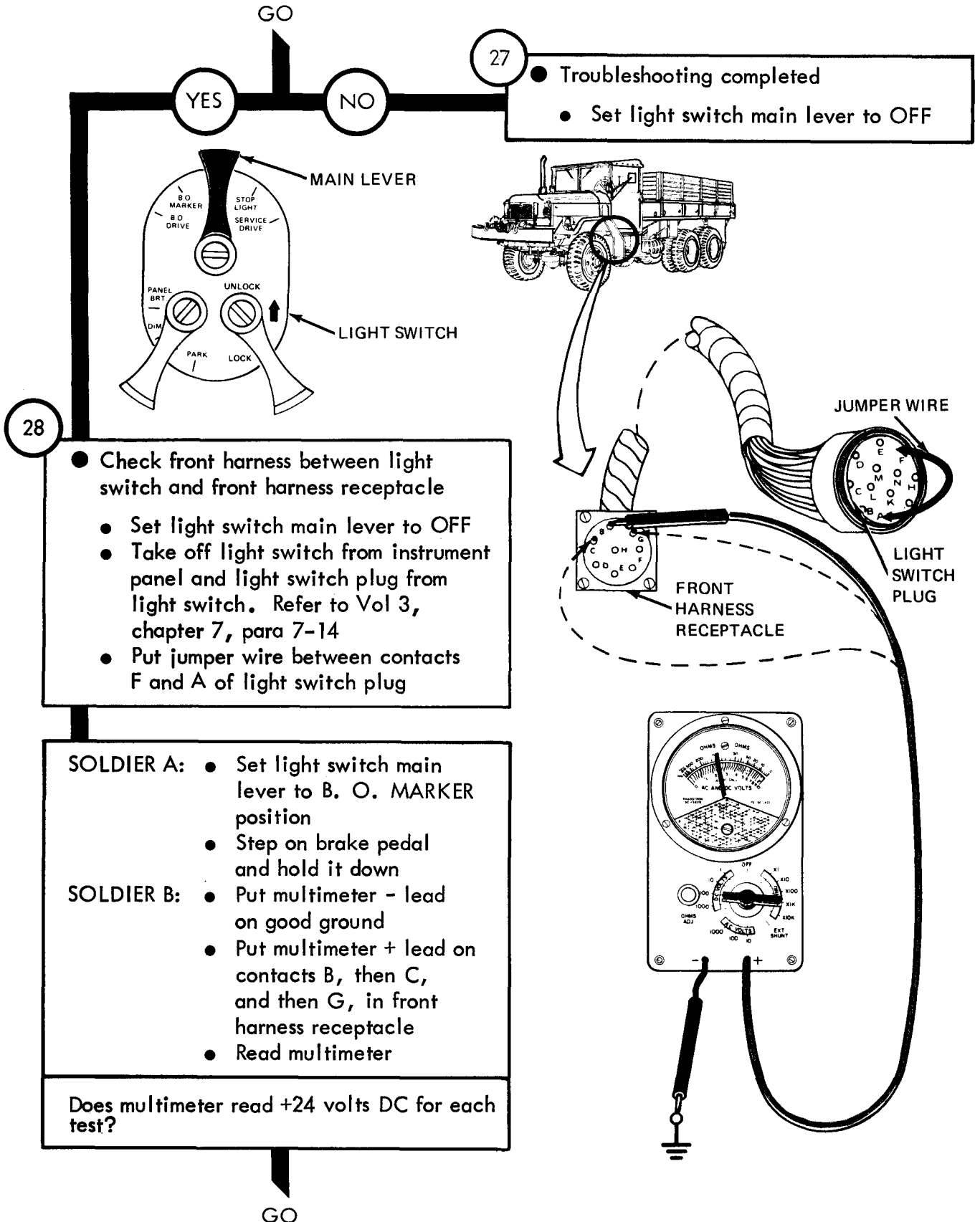

- 28
- Check front harness between light switch and front harness receptacle
 - Set light switch main lever to OFF
 - Take off light switch from instrument panel and light switch plug from light switch. Refer to Vol 3, chapter 7, para 7-14
 - Put jumper wire between contacts F and A of light switch plug

- SOLDIER A:
- Set light switch main lever to B. O. MARKER position
 - Step on brake pedal and hold it down
- SOLDIER B:
- Put multimeter - lead on good ground
 - Put multimeter + lead on contacts B, then C, and then G, in front harness receptacle
 - Read multimeter

Does multimeter read +24 volts DC for each test?

- 27
- Troubleshooting completed
 - Set light switch main lever to OFF

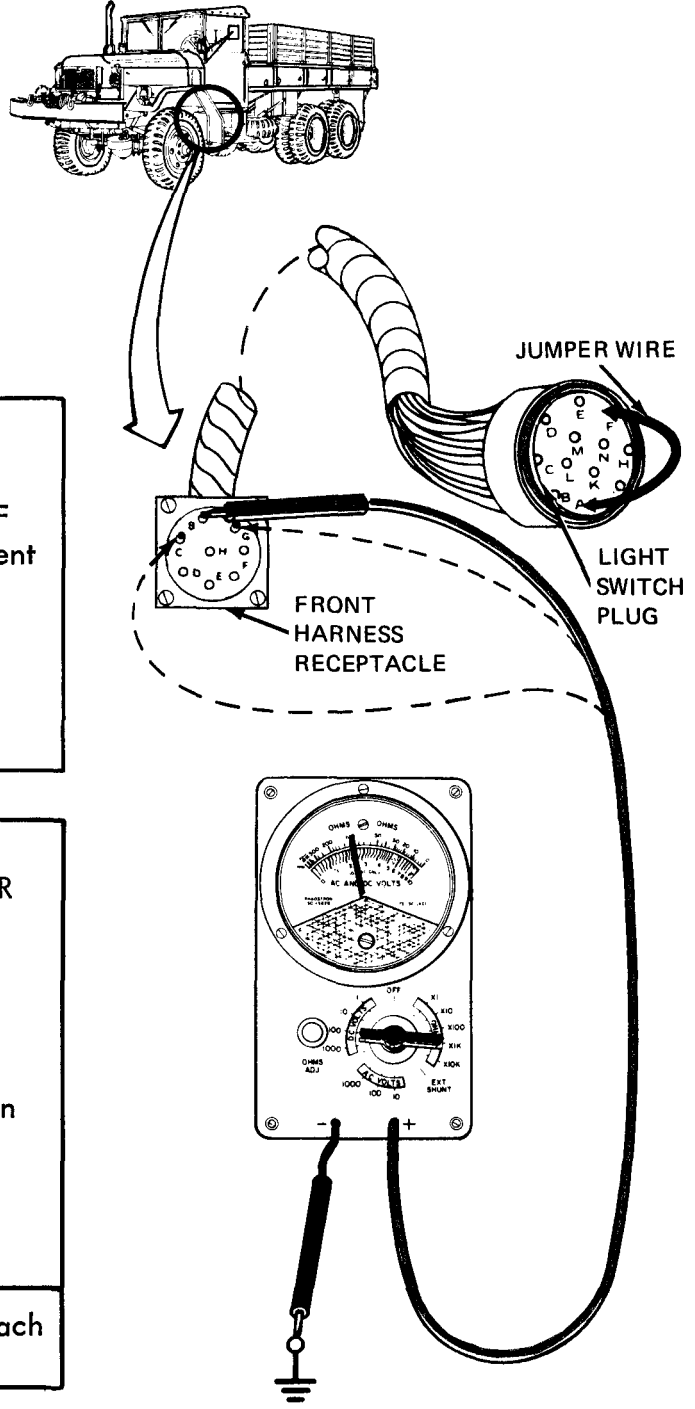

Figure 25-14 (Sheet 13 of 24)

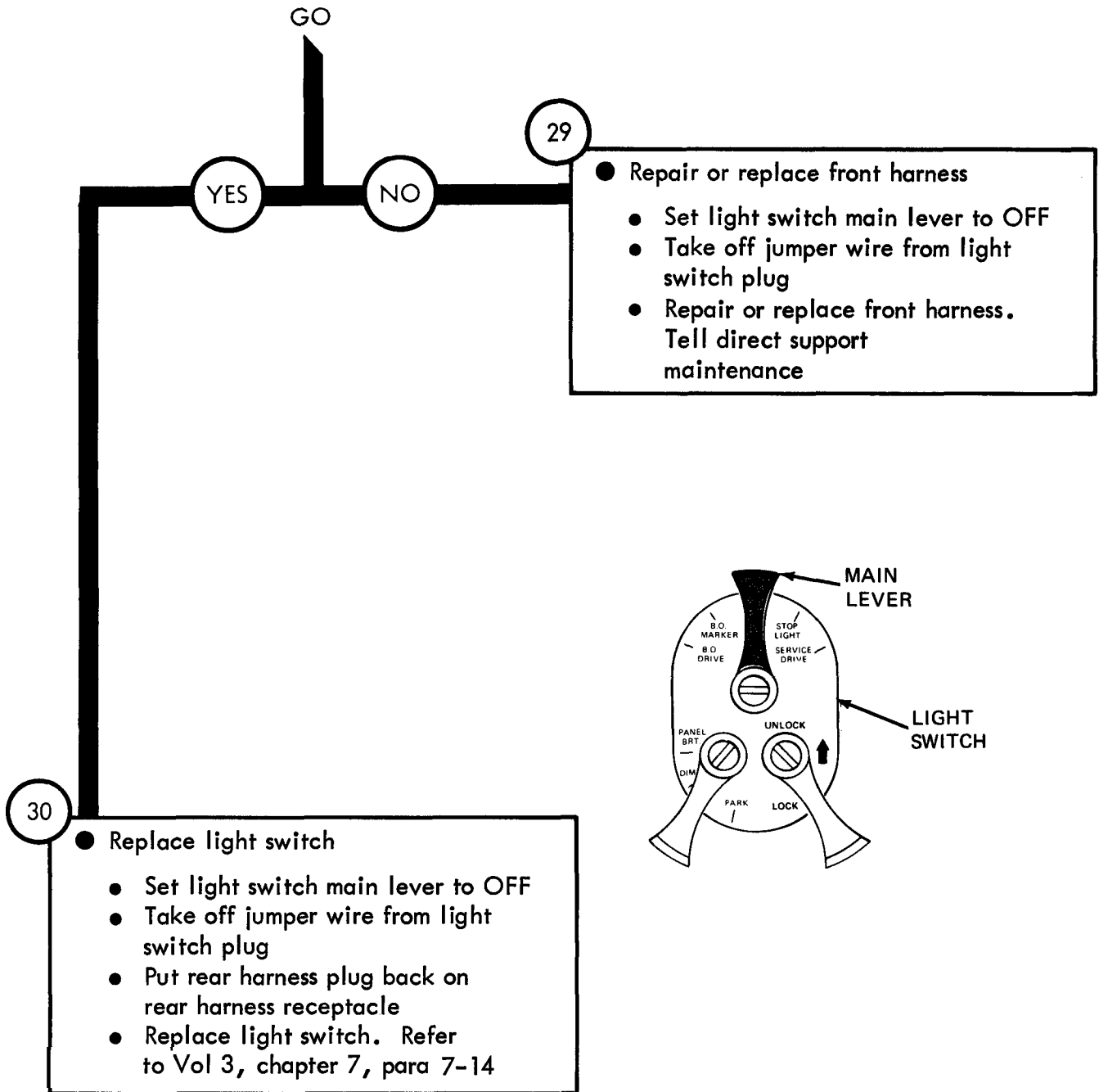

Figure 25-14 (Sheet 14 of 24)

From step 4

31

- Check for +24 volts at right blackout stoplight

- SOLDIER B: ● Using 9/16-inch wrench, unscrew and take off four screws with washers from right rear composite marker assembly
- Take off cover
 - Take off lead 23 from rear of right rear composite marker light assembly

- SOLDIER A: ● Set light switch main lever to B. O. MARKER position
- SOLDIER B: ● Put multimeter + lead on lead 23 and - lead on a good ground
- SOLDIER A: ● Press down on brake pedal and hold it down
- SOLDIER B: ● Read multimeter while Soldier A presses down on brake pedal. Multimeter should measure +24 volts DC

Does multimeter measure less than +24 volts DC?

GO

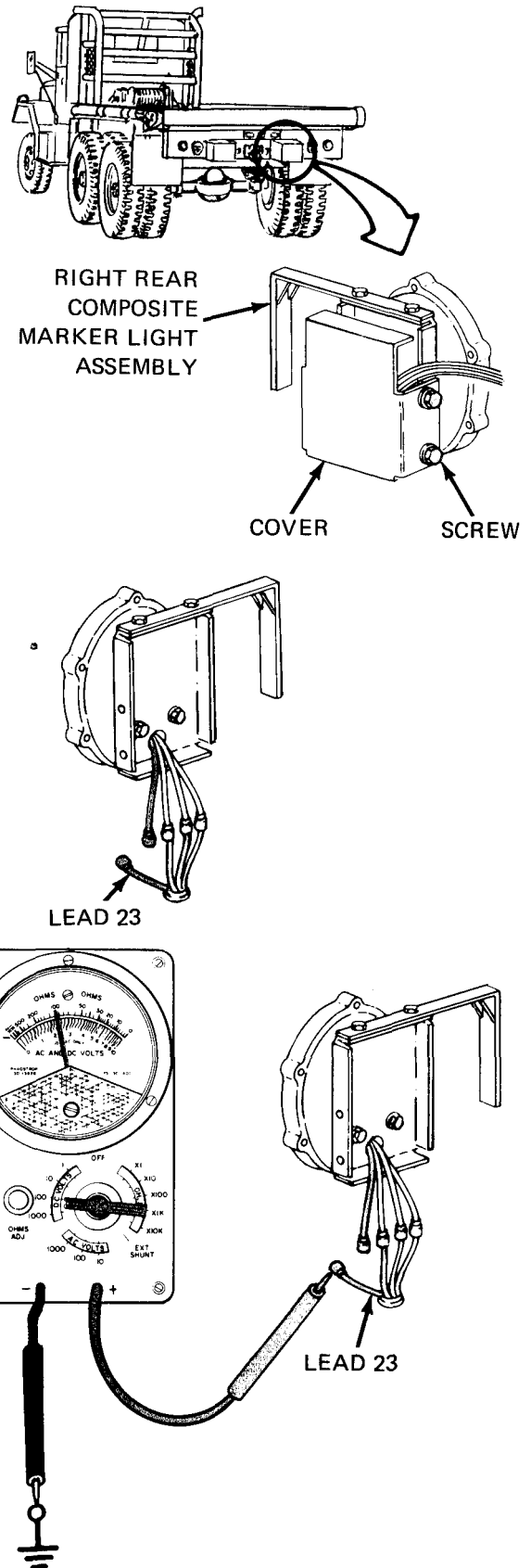

TA 114350

Figure 25-14 (Sheet 15 of 24)

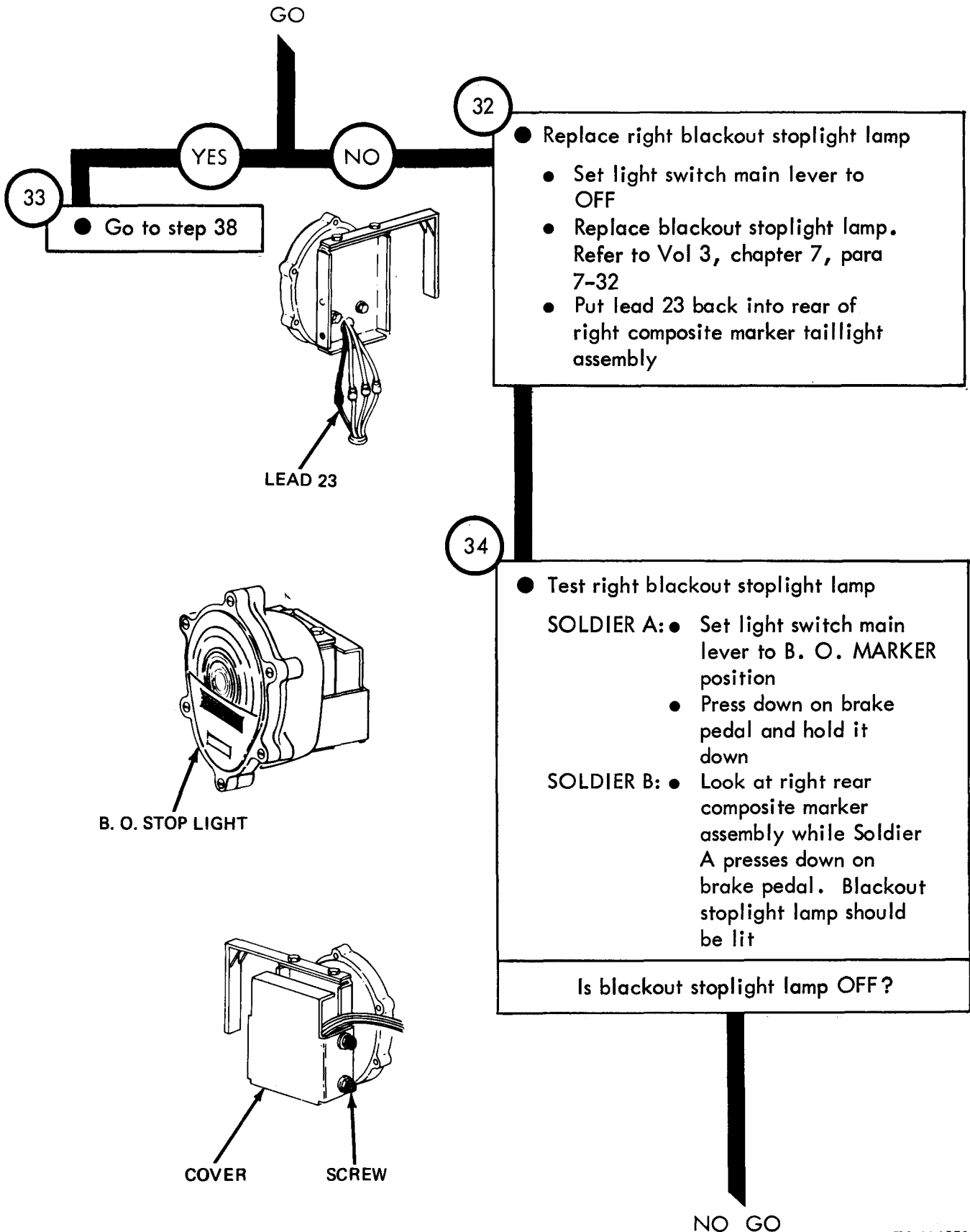

TA 114351

Figure 25-14 (Sheet 16 of 24)

NO GO

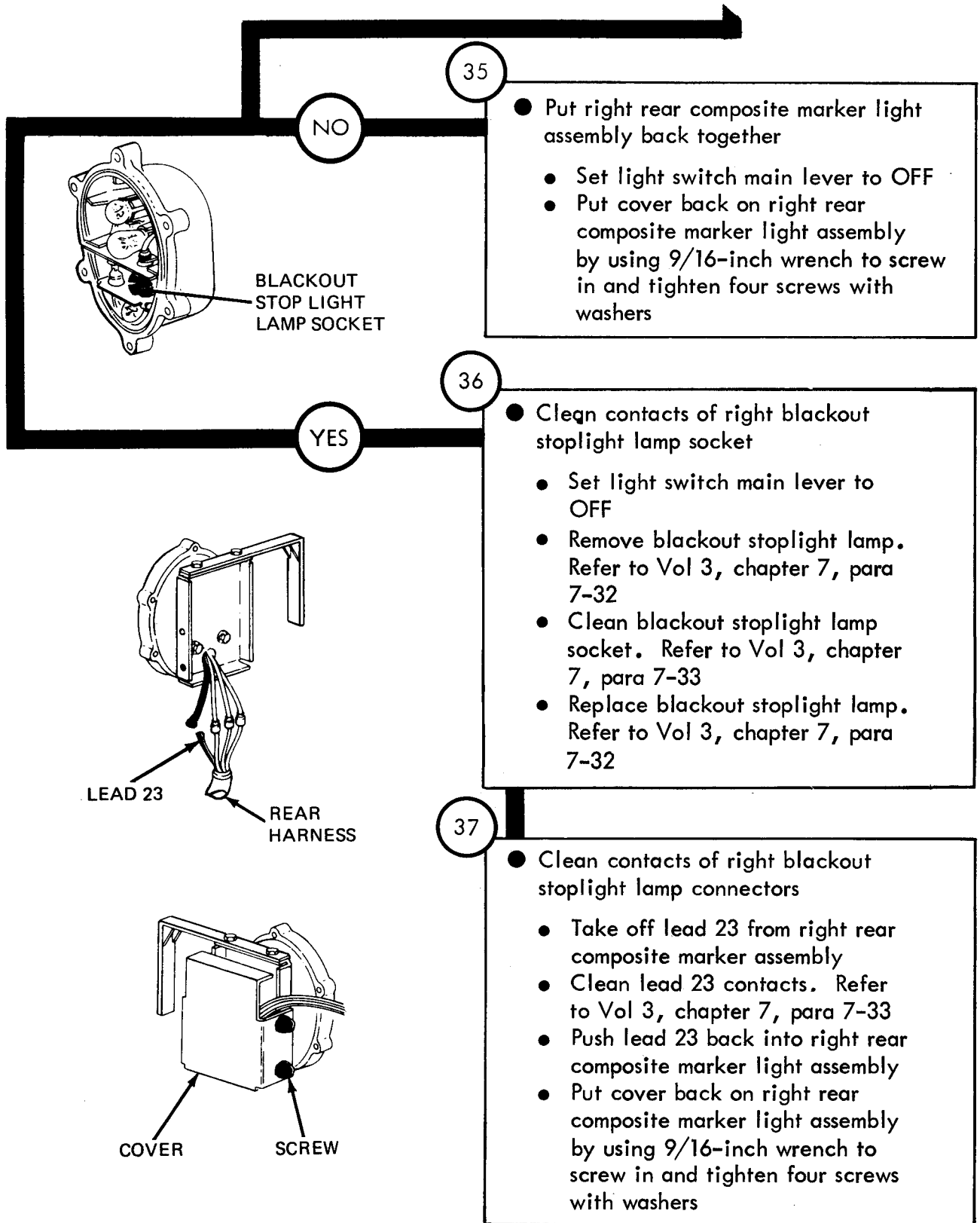

TA 114352

Figure 25-14 (Sheet 17 of 24)

From step 33

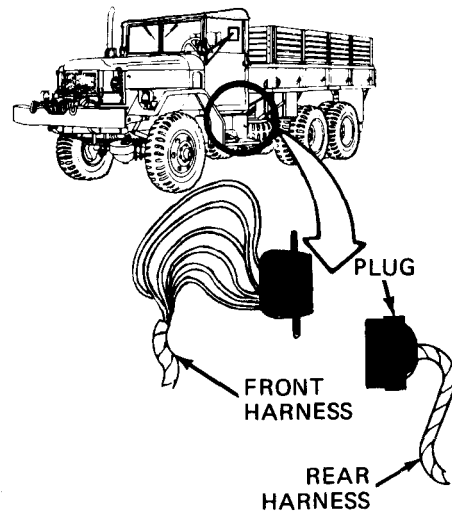

38

- Check voltage to front and rear harness connectors
- SOLDIER B: ● Take rear harness plug from front harness receptacle.
- SOLDIER A: ● Step on brake pedal and hold it down
- SOLDIER B: ● Put multimeter - lead on a good ground. Put multimeter + lead on contact B of front harness receptacle
- Read multimeter for +24 volts DC while Soldier A presses on brake pedal

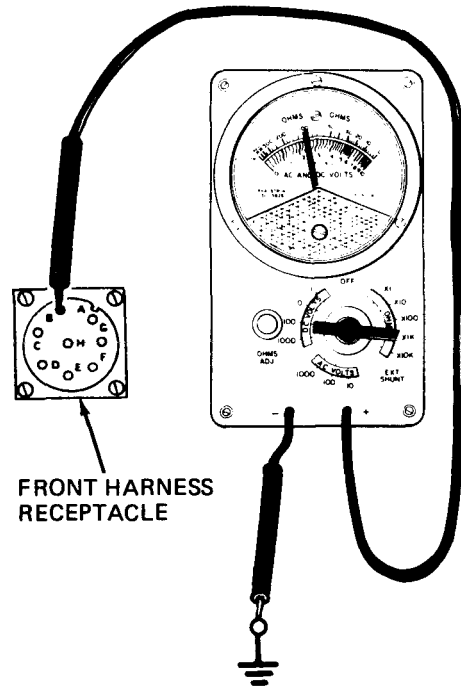

Does multimeter read +24 volts DC?

YES NO

39

- Repair or replace front harness
- Set light switch main lever to OFF
- Repair or replace front harness. Tell direct support maintenance

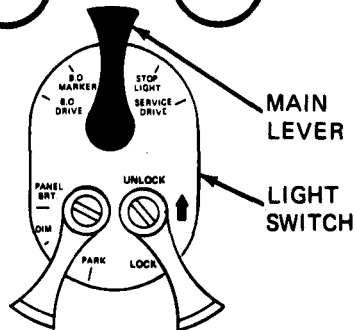

GO

TA 114353

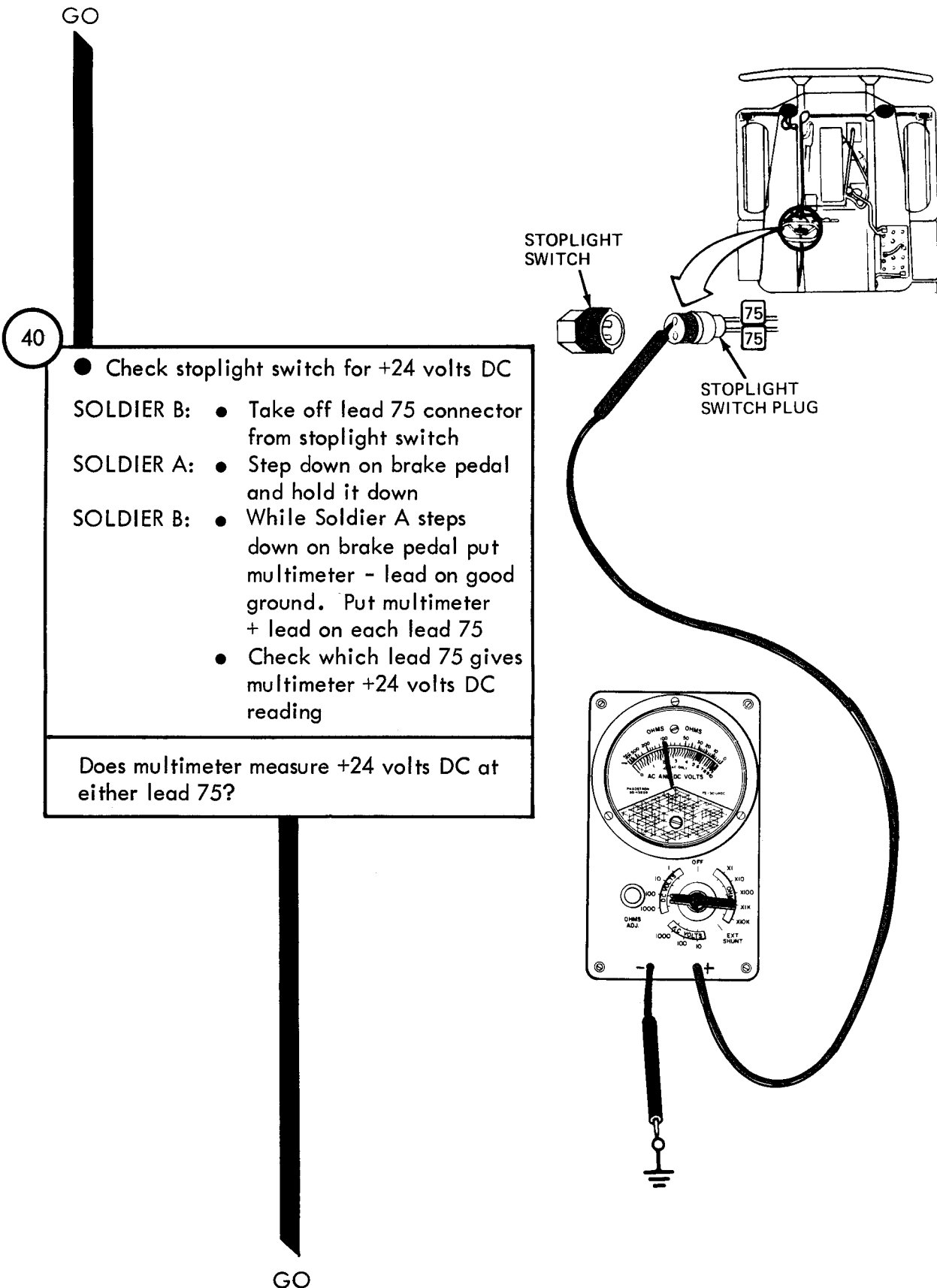
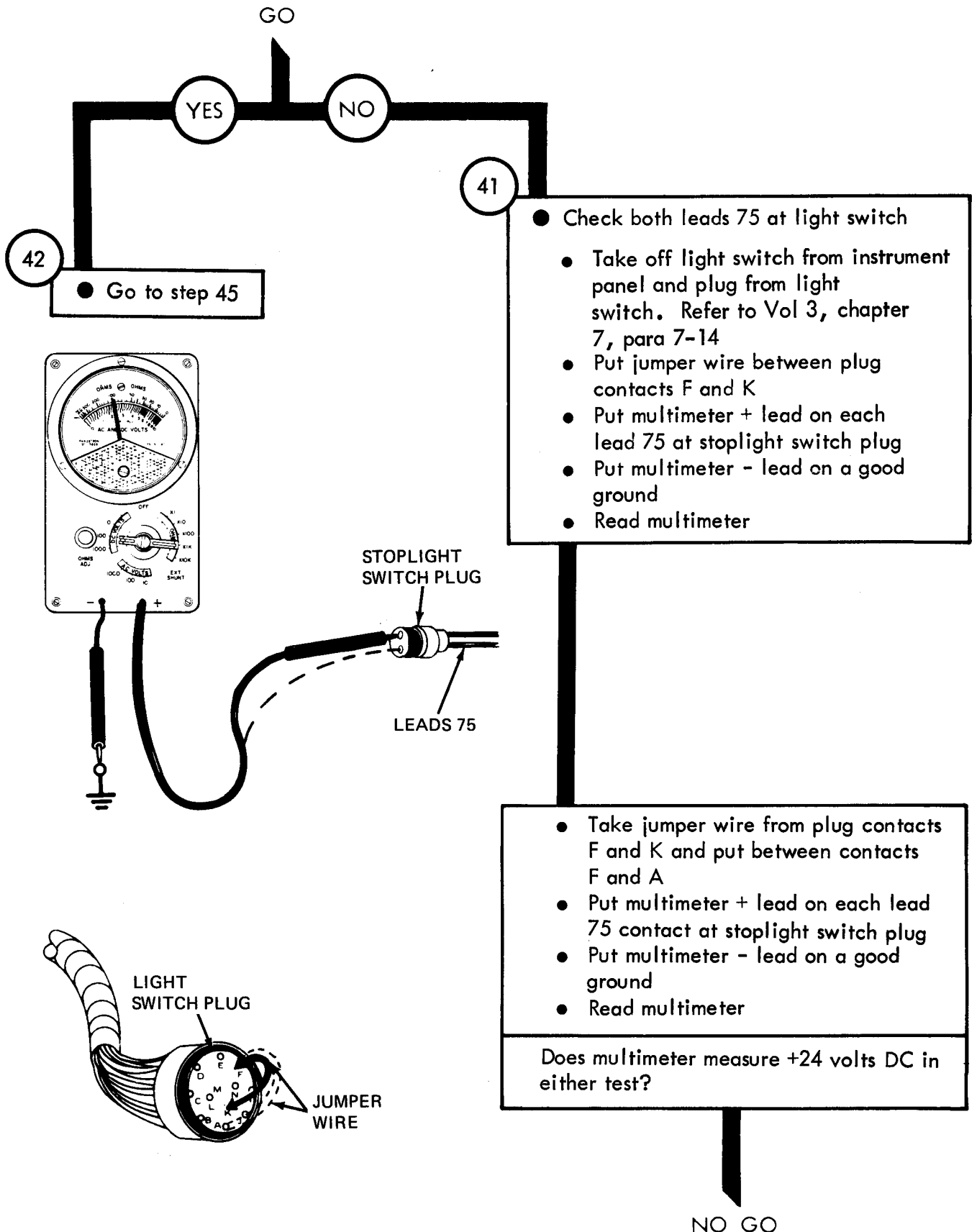

Figure 25-14 (Sheet 19 of 24)



- Check both leads 75 at light switch
 - Take off light switch from instrument panel and plug from light switch. Refer to Vol 3, chapter 7, para 7-14
 - Put jumper wire between plug contacts F and K
 - Put multimeter + lead on each lead 75 at stoplight switch plug
 - Put multimeter - lead on a good ground
 - Read multimeter

- Take jumper wire from plug contacts F and K and put between contacts F and A
- Put multimeter + lead on each lead 75 contact at stoplight switch plug
- Put multimeter - lead on a good ground
- Read multimeter

Does multimeter measure +24 volts DC in either test?

NO GO

Figure 25-14 (Sheet 20 of 24)

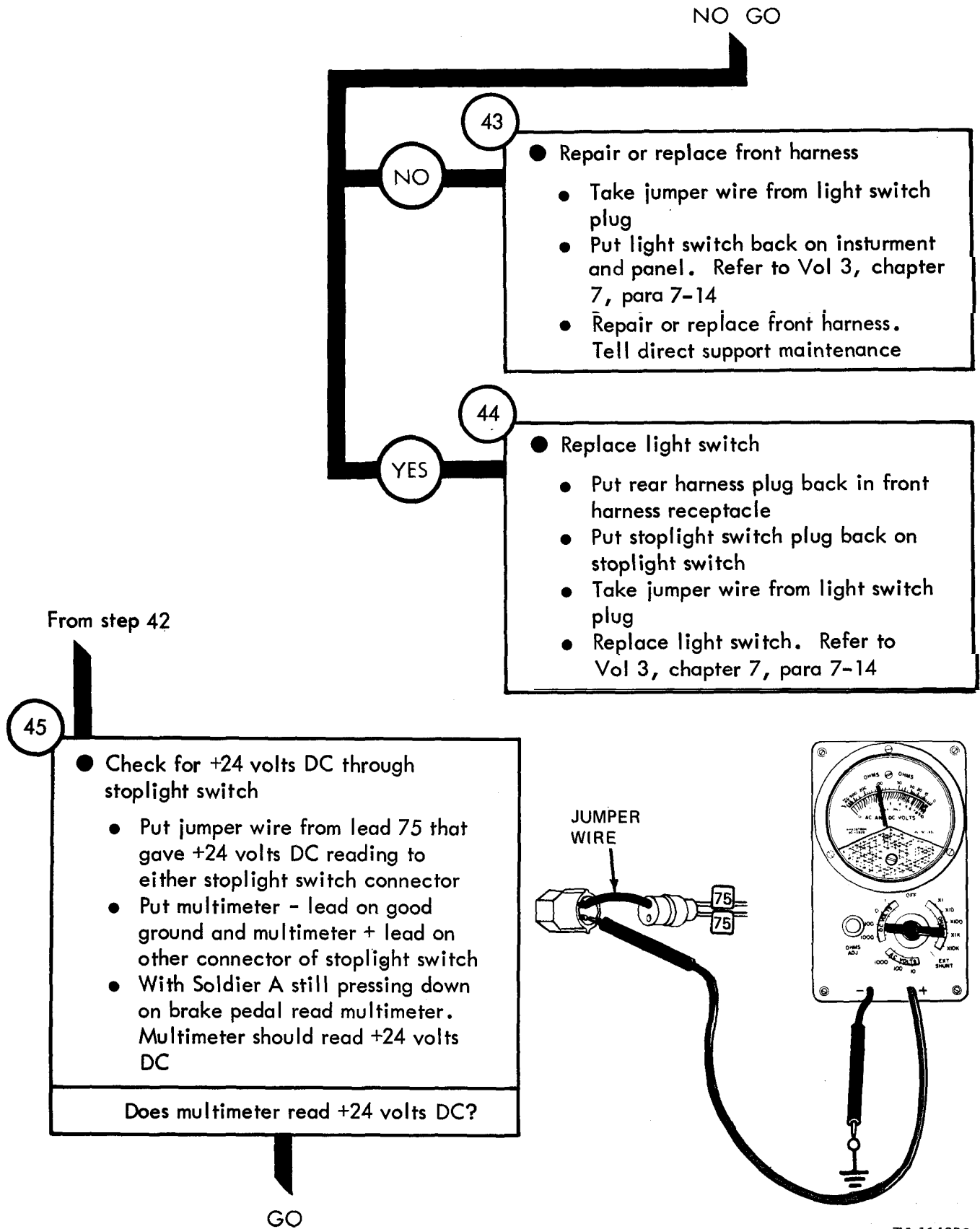
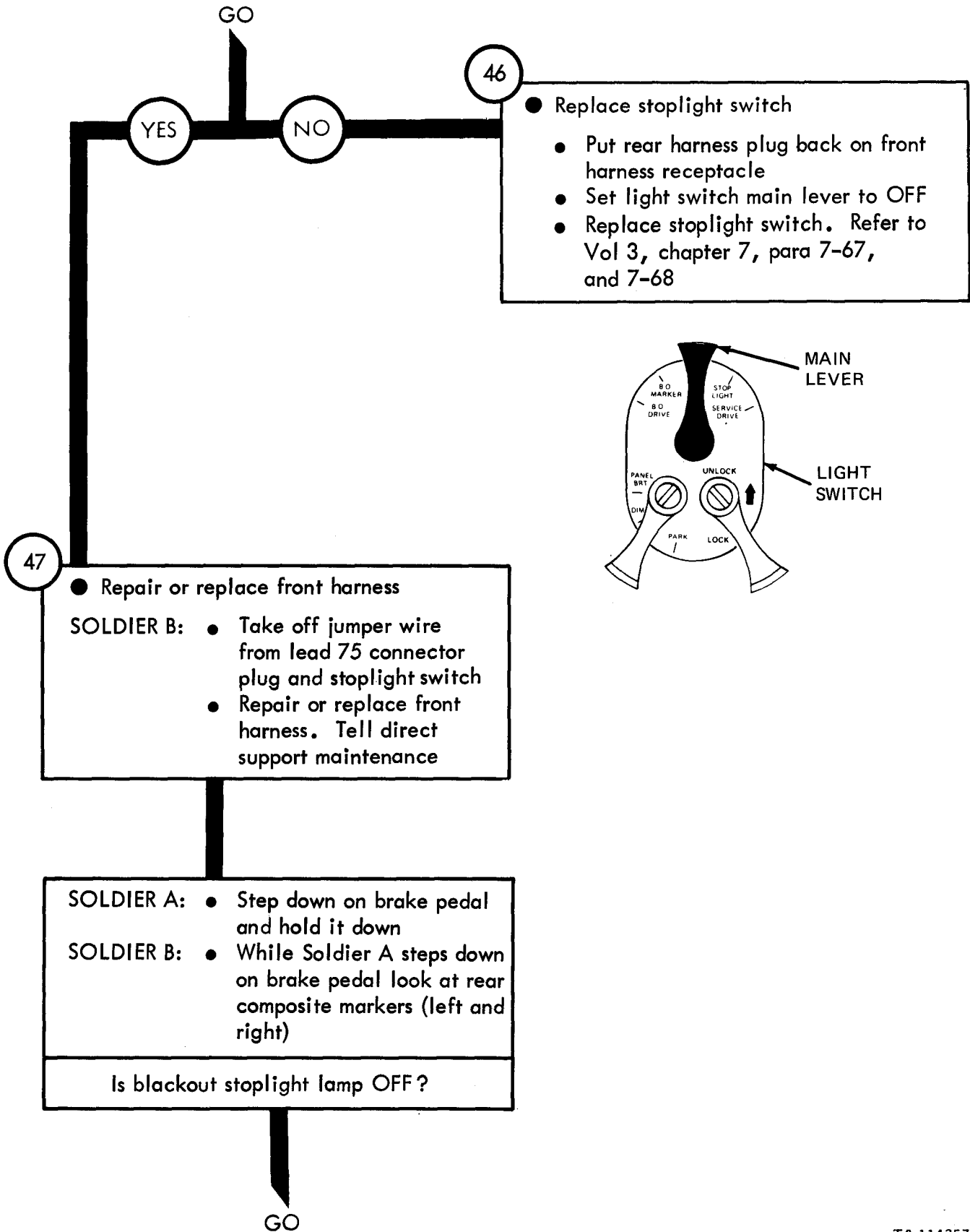
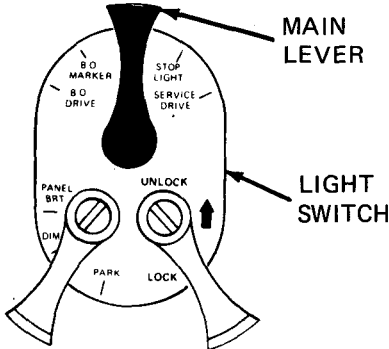

Figure 25-14 (Sheet 21 of 24)



46

- Replace stoplight switch
 - Put rear harness plug back on front harness receptacle
 - Set light switch main lever to OFF
 - Replace stoplight switch. Refer to Vol 3, chapter 7, para 7-67, and 7-68



47

- Repair or replace front harness

SOLDIER B:

- Take off jumper wire from lead 75 connector plug and stoplight switch
- Repair or replace front harness. Tell direct support maintenance

SOLDIER A:

- Step down on brake pedal and hold it down

SOLDIER B:

- While Soldier A steps down on brake pedal look at rear composite markers (left and right)

Is blackout stoplight lamp OFF?

Figure 25-14 (Sheet 22 of 24)

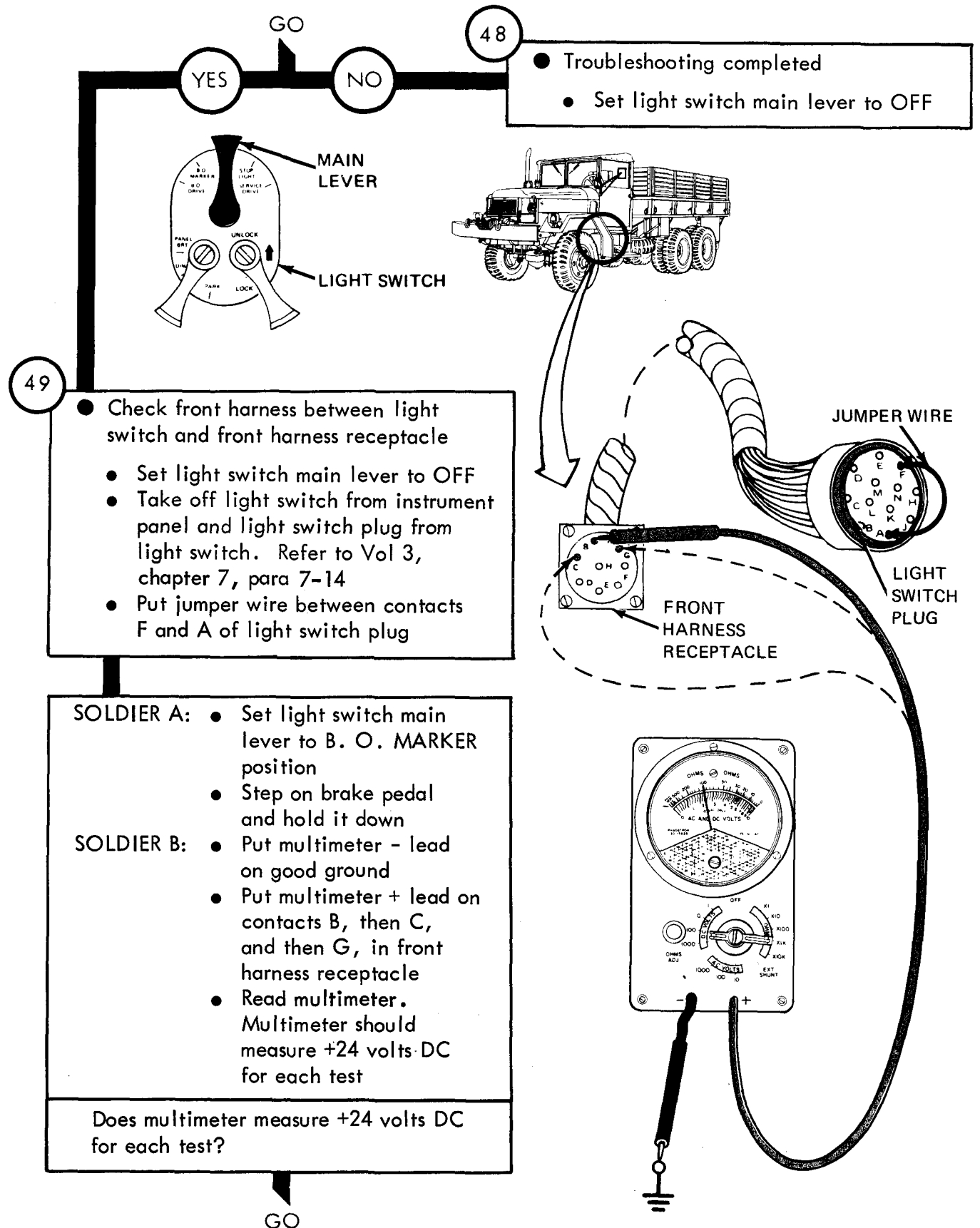

48

- Troubleshooting completed
- Set light switch main lever to OFF

49

- Check front harness between light switch and front harness receptacle
- Set light switch main lever to OFF
- Take off light switch from instrument panel and light switch plug from light switch. Refer to Vol 3, chapter 7, para 7-14
- Put jumper wire between contacts F and A of light switch plug

SOLDIER A:

- Set light switch main lever to B. O. MARKER position
- Step on brake pedal and hold it down

SOLDIER B:

- Put multimeter - lead on good ground
- Put multimeter + lead on contacts B, then C, and then G, in front harness receptacle
- Read multimeter. Multimeter should measure +24 volts DC for each test

Does multimeter measure +24 volts DC for each test?

GO

Figure 25-14 (Sheet 23 of 24)

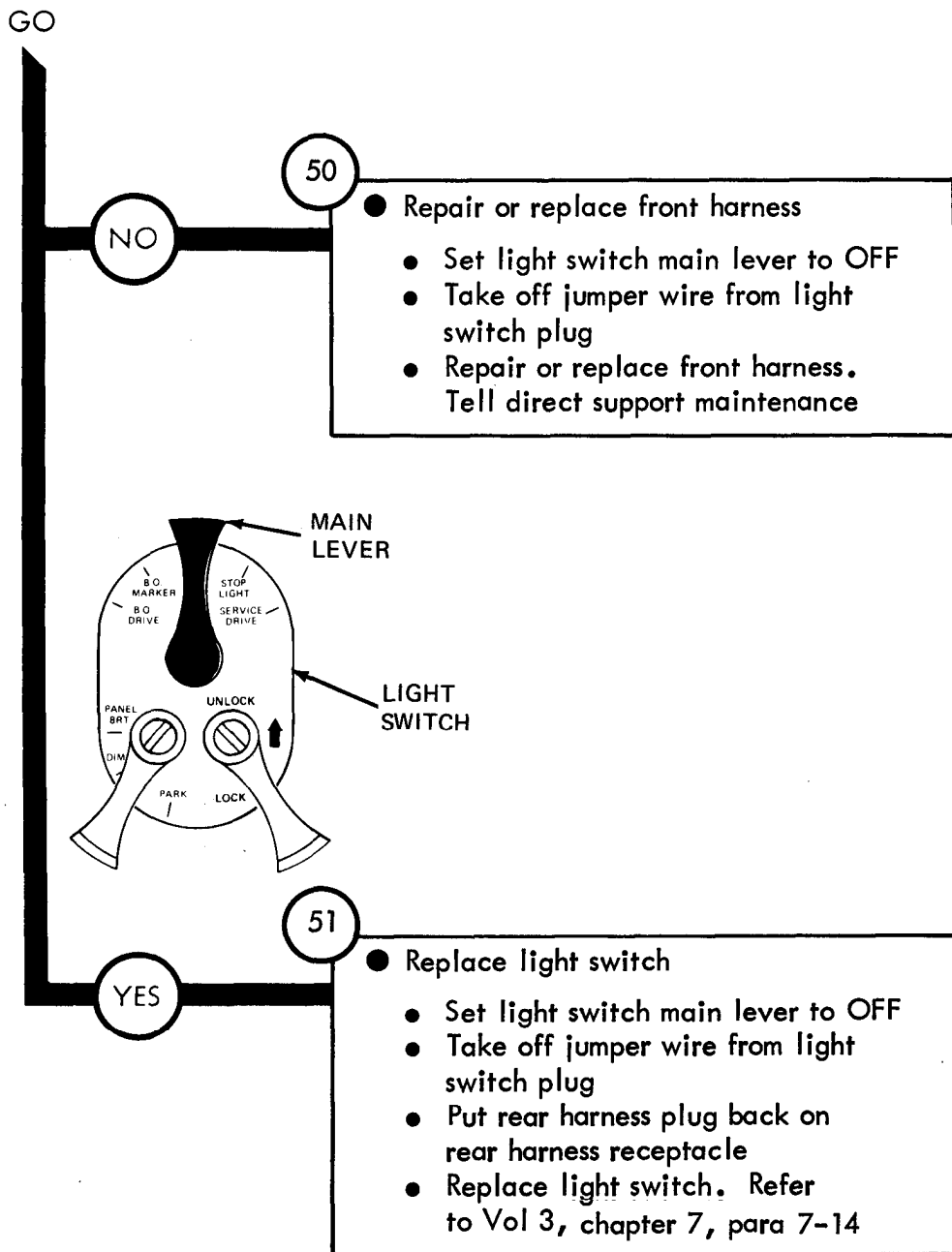

Figure 25-14 (Sheet 24 of 24)

Symptom

15

ONE OR BOTH SERVICE TAILLIGHT LIGHTS DO NOT LIGHT, OTHER TRUCK RUNNING LIGHTS LIGHT

NOTE

Do this procedure for each taillight lamp that does not light. Procedure is the same for both service taillights

When checking voltage, +24 volts DC means a range of +23 to +26 volts DC

1

- Park truck
- Refer to TM9-2320-209-10

GO

GO

2

- Check for +24 volts at taillight lamp
 - Using 9/16-inch wrench, unscrew and take off four screws with washers from rear composite marker assembly
 - Take off cover
 - Take off lead 21

- Set light switch main lever to SERVICE DRIVE
- Set multimeter to read +24 volts DC. Refer to test equipment procedures index.
- Put multimeter + lead on lead 21 contact
- Put multimeter - lead on a good ground
- Read multimeter. Multimeter should measure +24 volts DC

Does multimeter measure less than +24 volts DC?

GO

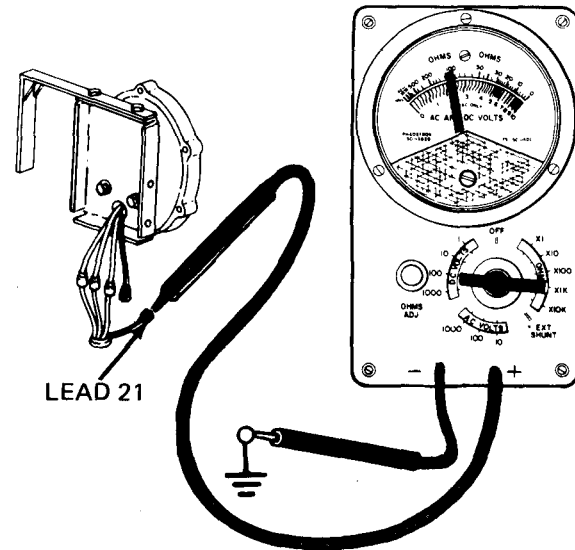
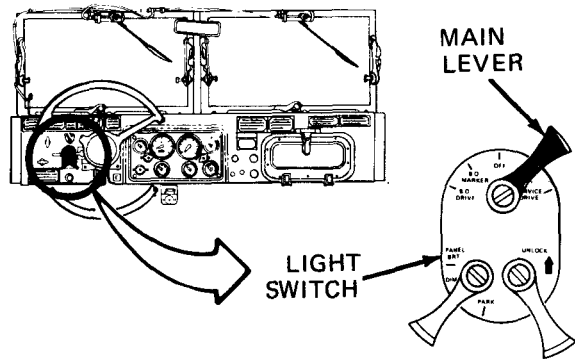
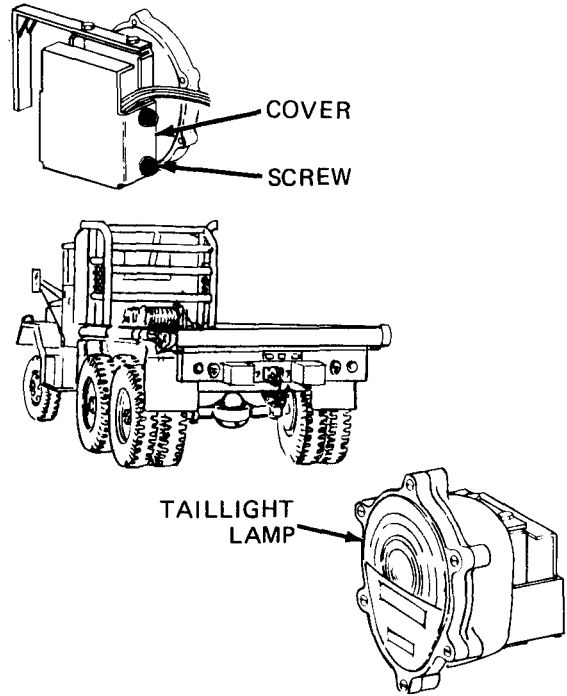

TA 114361

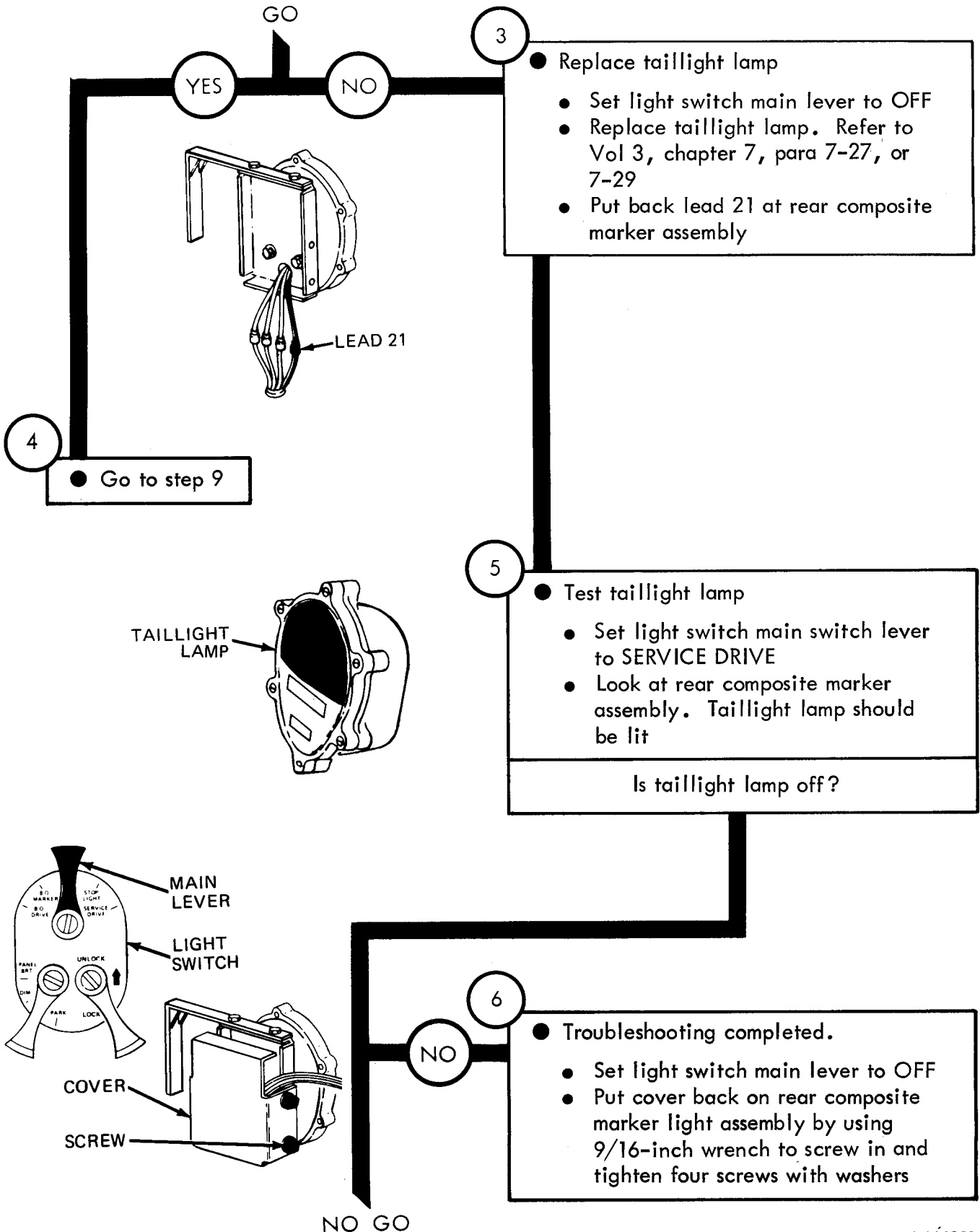

TA 114362

Figure 25-15 (Sheet 3 of 7)

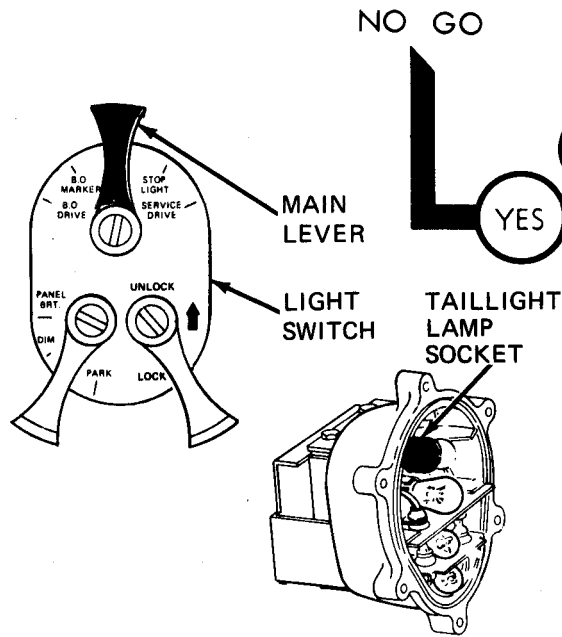

- 7
- Clean contacts of taillight lamp socket
 - Set light switch main lever to OFF
 - Remove taillight lamp. Refer to Vol 3, chapter 7, para 7-27 or 7-29
 - Clean taillight lamp socket. Refer to Vol 3, chapter 2, para 7-26 or 7-30
 - Replace taillight lamp. Refer to Vol 3, chapter 7, para 7-27 or 7-29

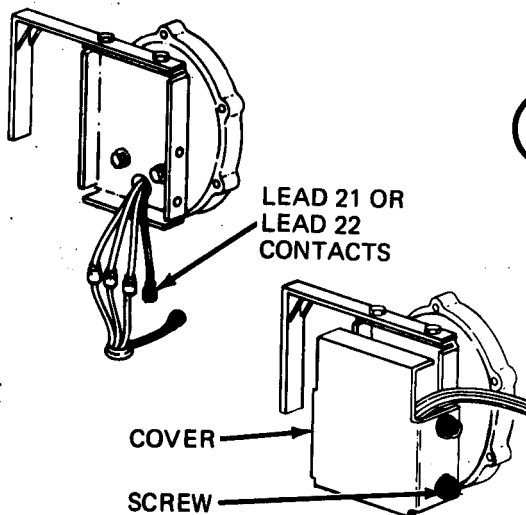

- 8
- Clean contacts of taillight connectors
 - Take off lead 21
 - Clean lead 21 contacts. Refer to Vol 3, chapter 7, para 7-26 or 7-30
 - Push lead 21 back into connector
 - Put cover back on rear composite marker light assembly by using 9/16-inch wrench to screw in and tighten four screws with washers

Figure 25-15 (Sheet 4 of 7)

From step 4

9

- Check rear harness between taillight lamp and rear harness connector
 - Set light switch main lever to OFF
 - Unscrew and take off rear harness plug from front harness connector
 - Put multimeter + lead on contact E in front harness connectors
 - Put multimeter - lead on a good ground
 - Read multimeter. Multimeter should measure +24 volts DC
- Does multimeter measure less than +24 volts DC?

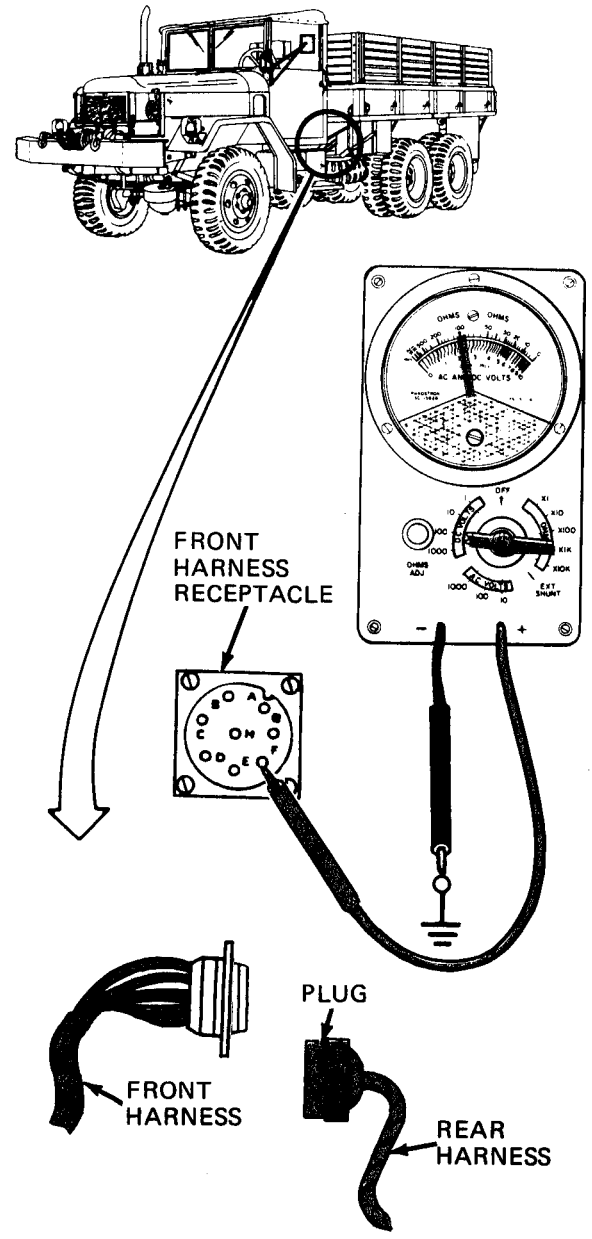

YES

NO

10

- Repair or replace rear harness
- Tell direct support maintenance

GO

GO

11

- Check front harness between light switch and front harness connector
 - Take off light switch from instrument panel. Refer to Vol 3, chapter 7, para 7-14. Take off light switch plug from light switch. Refer to Vol 3, chapter 7, para 7-14
 - Put jumper wire between contacts F and H of light switch plug
 - Put multimeter + lead on contact E in front harness connector
 - Put multimeter - lead on good ground. Read multimeter. Multimeter should measure +24 volts DC
- Does multimeter measure +24 volts DC?

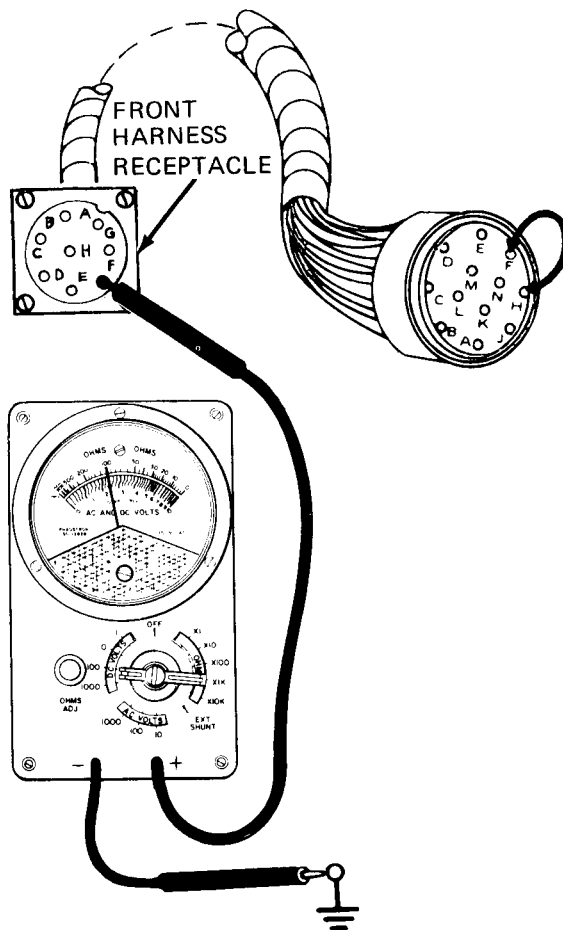

YES

NO

12

- Repair or replace front harness
- Take off jumper wire from light switch plug
- Put light switch back on instrument panel. Refer to Vol 3, chapter 7, para 7-14
- Put back lead 21 at rear composite marker light assembly
- Put cover back on rear composite marker light assembly by using 9/16-inch wrench to screw in and tighten four screws with washers

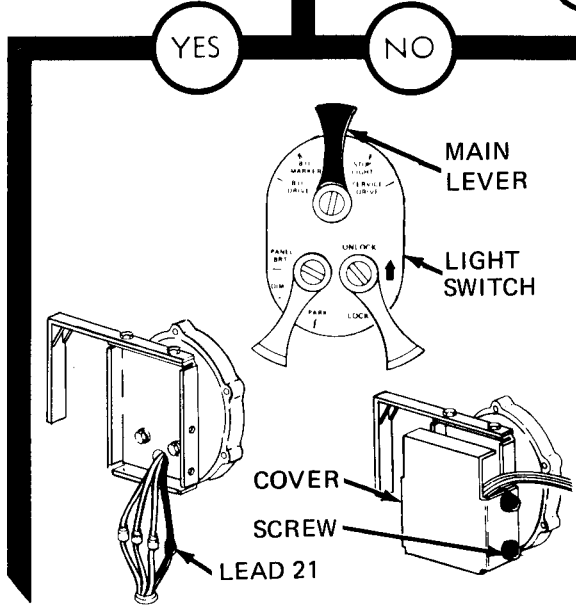

GO

GO

13

- Replace light switch
 - Take off jumper wire from light switch plug
 - Put front harness connector back on rear harness plug and screw on tight
 - Put lead 21 back in rear composite marker light assembly
 - Put cover back on rear composite marker light assembly by using 9/16-inch wrench to screw in and tighten four screws with washers
 - Replace light switch. Refer to Vol 3, chapter 7, para 7-14

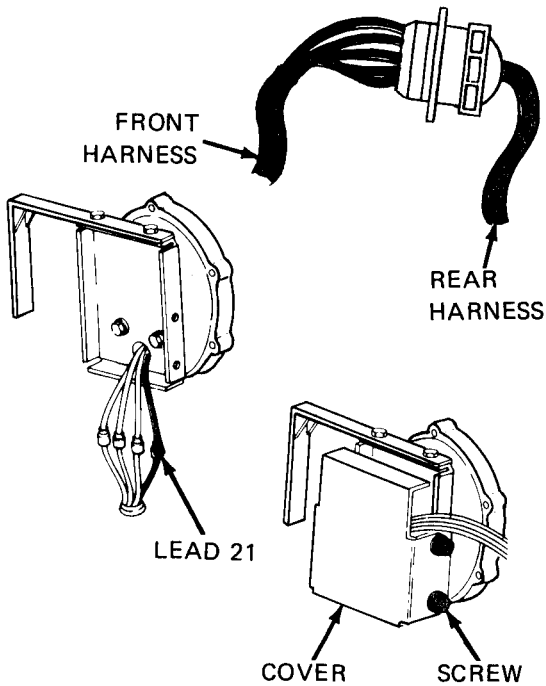
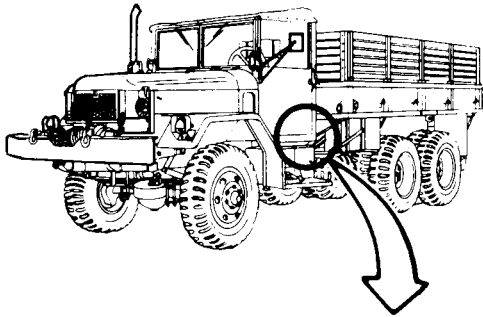
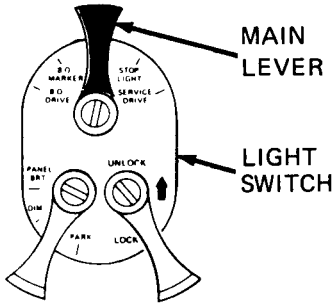

Symptom

16

ONE OR BOTH REAR BLACKOUT MARKER LIGHTS DO NOT LIGHT, OTHER TRUCK RUNNING LIGHTS LIGHT

NOTE

Do this procedure for each blackout marker light that does not light.
When measuring voltage +24 volts DC means a range of +23 to +26 volts DC

1

- Park truck
- Refer to TM 9-2320-209-10

GO

TA 114367

GO

2

- Check for +24 volts DC at rear blackout marker
 - Using 9/16-inch wrench, unscrew and take off four screws with washers from rear composite marker assembly
 - Take off cover
 - Take off lead 24 from rear composite marker assembly
 - Set light switch main lever to B.O. MARKER

- Set multimeter to measure +24 volts DC. Refer to test equipment procedures index
- Put multimeter + lead on lead 24 and - lead on a good ground
- Read multimeter. Multimeter should measure +24 volts DC

Does multimeter measure less than +24 volts DC?

GO

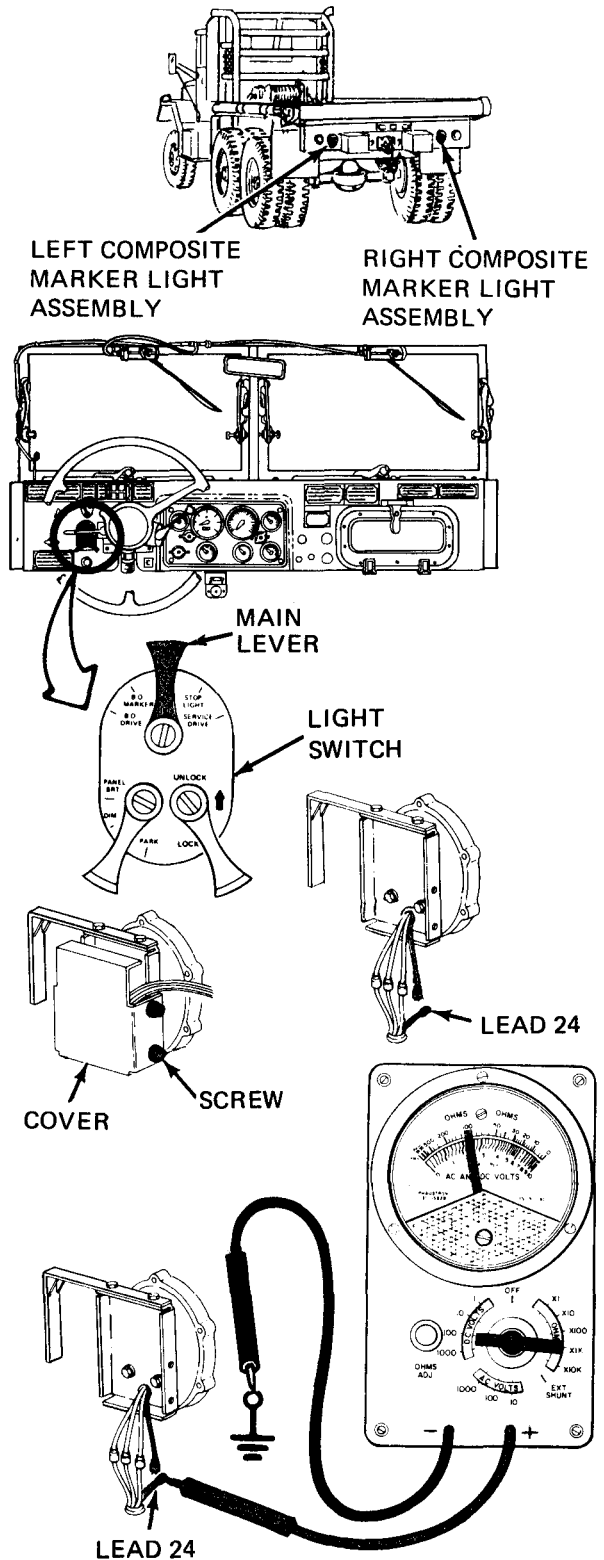

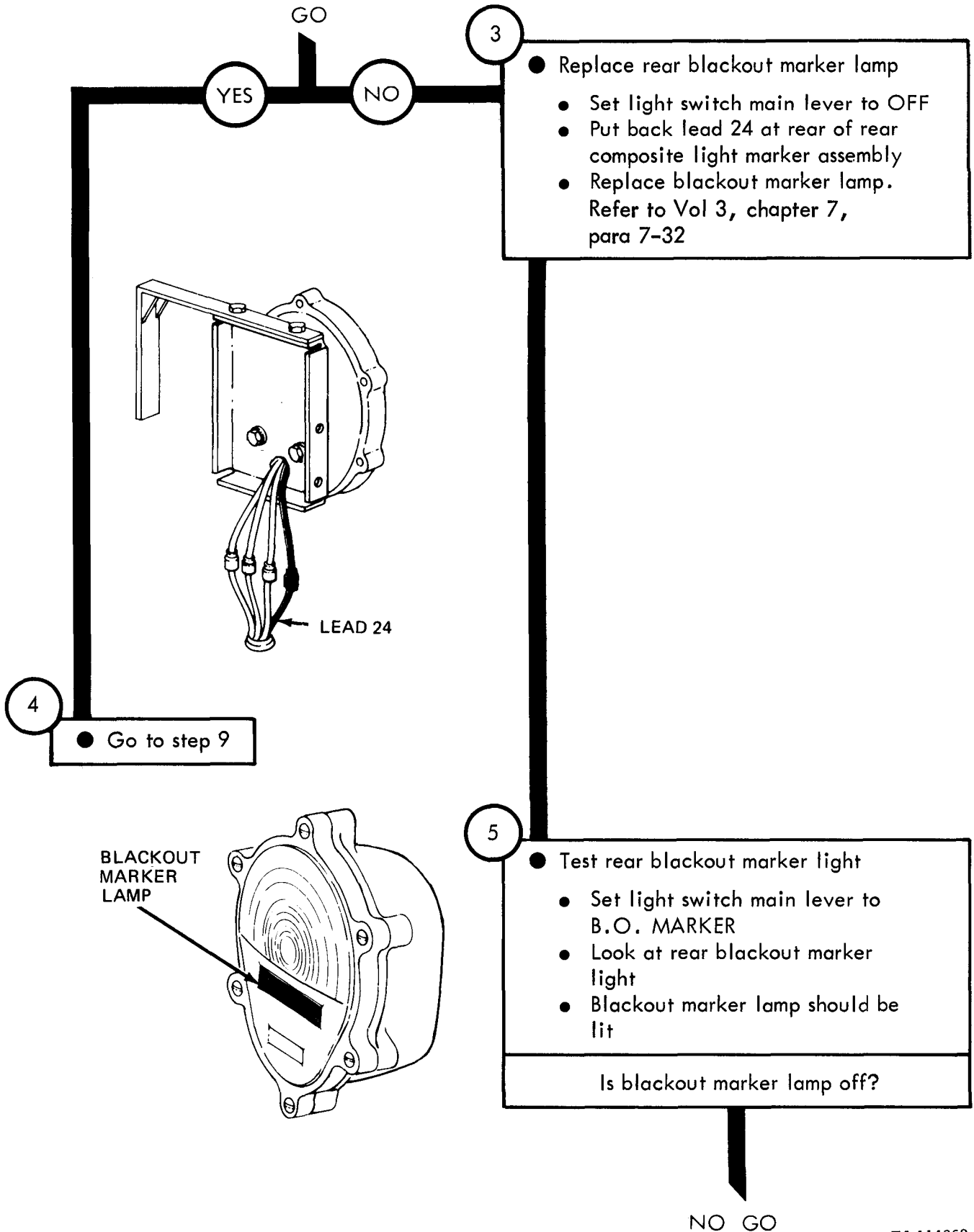

NO GO

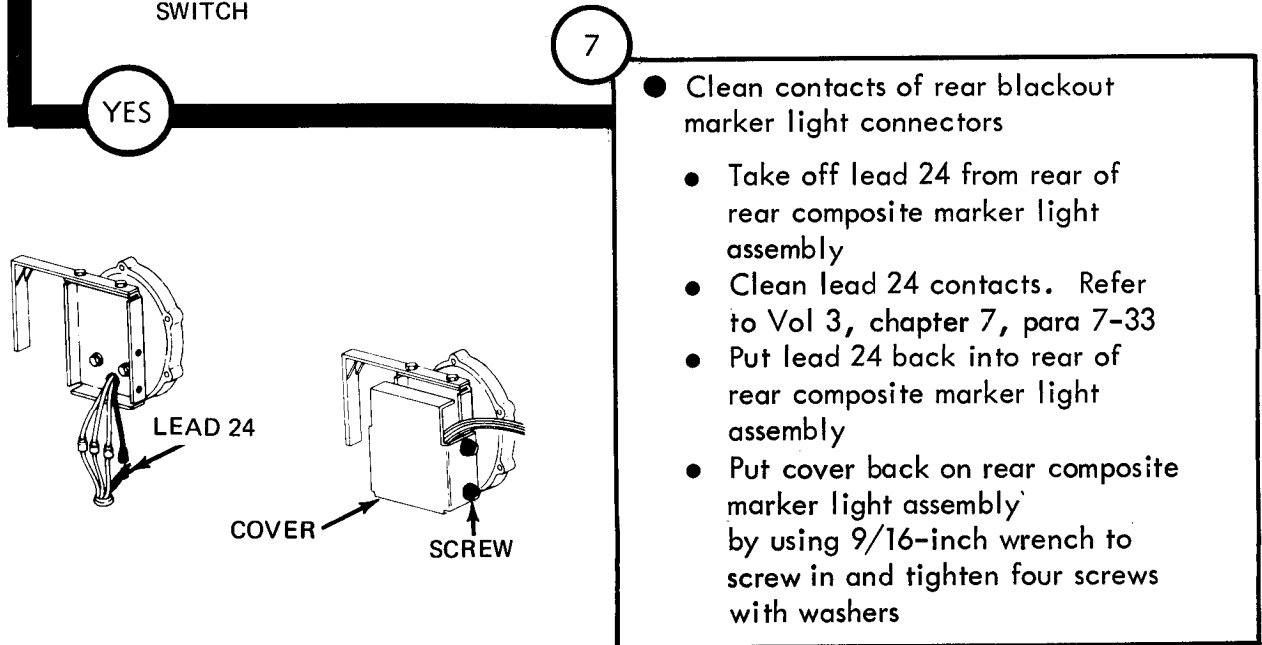
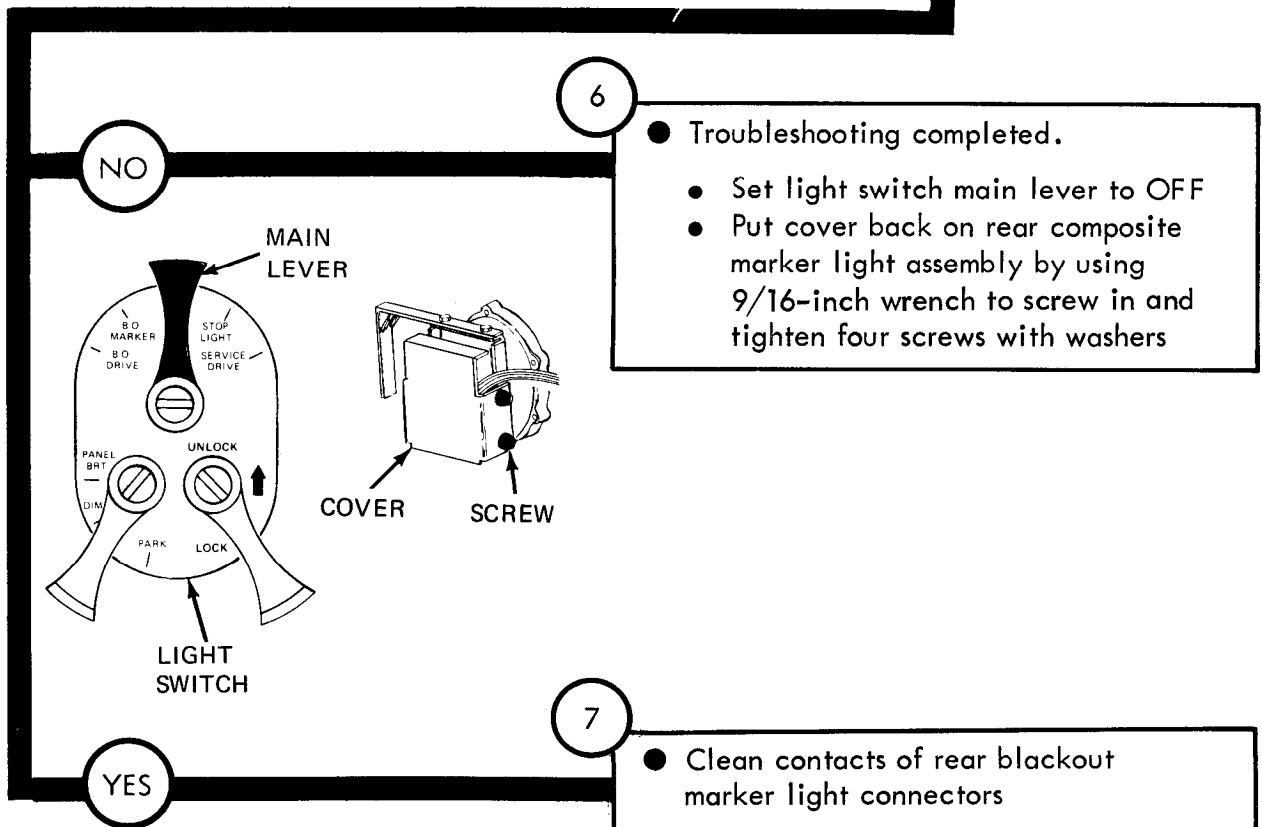

NO GO

Figure 25-16 (Sheet 4 of 7)

NO GO

8

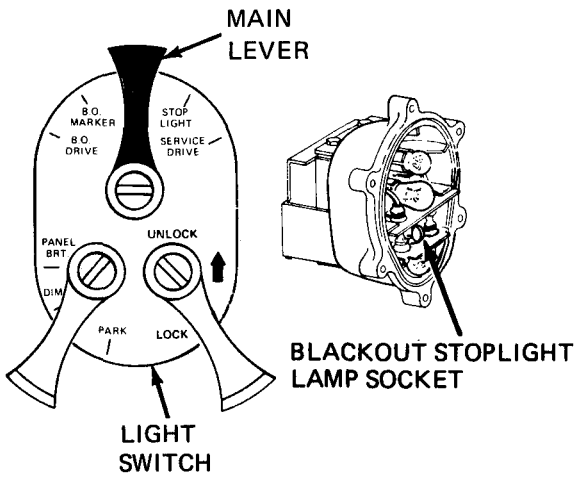

- Clean contacts off rear blackout marker lamp socket
- Set light switch main lever to OFF
- Remove blackout marker lamp. Refer to Vol 3, chapter 7, para 7-32
- Clean blackout marker lamp socket. Refer to Vol 3, chapter 7, para 7-33
- Put back blackout marker lamp. Refer to Vol 3, chapter 7, para 7-32

From step 4

9

- Check harness between rear blackout marker lamp and rear harness connector
- Set light switch main lever to OFF
- Unscrew and take off plug from front harness receptacle
- Set light switch main lever to B.O. MARKER
- Put multimeter + lead on contact D in front harness receptacle and - lead on good ground
- Read multimeter. Multimeter should measure +24 volts DC

Does multimeter measure less than +24 volts DC?

GO

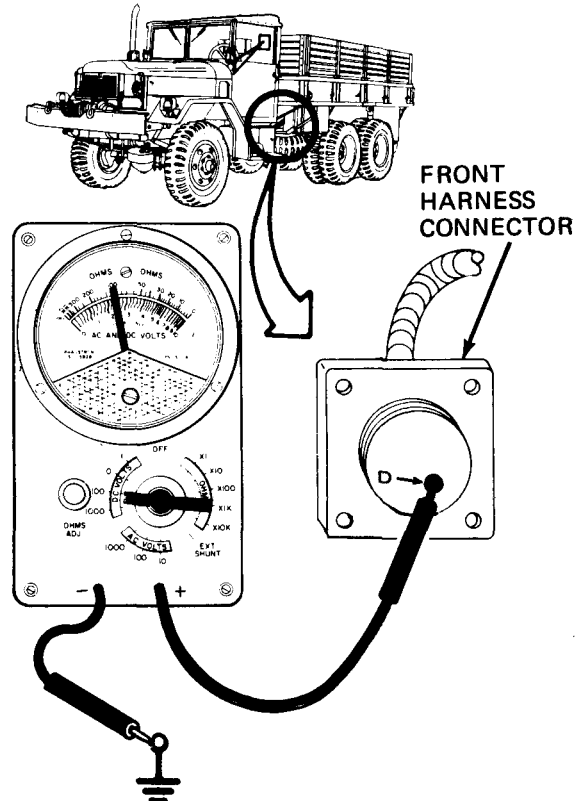

TA 114371

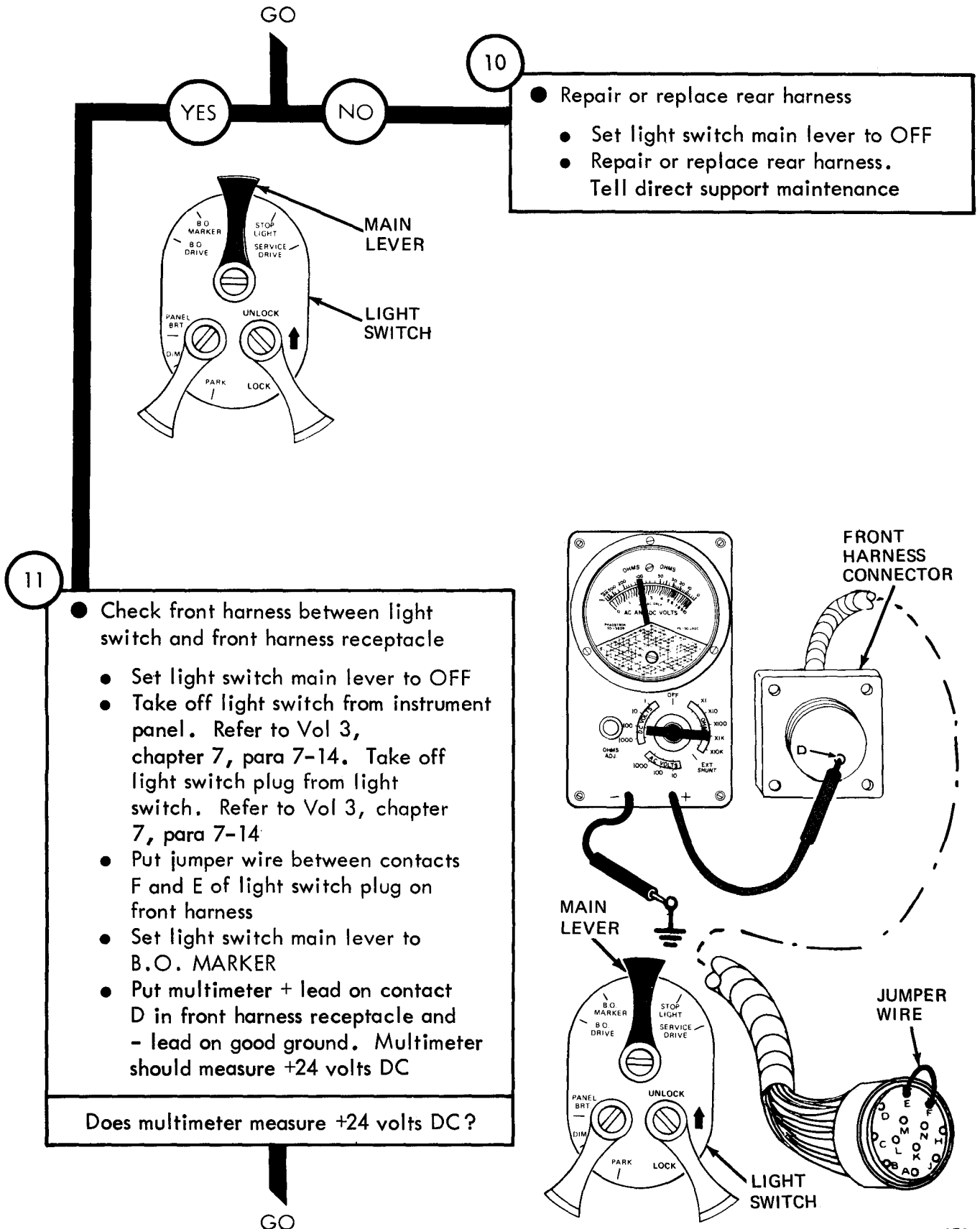

TA 114372

Figure 25-16 (Sheet 6 of 7)

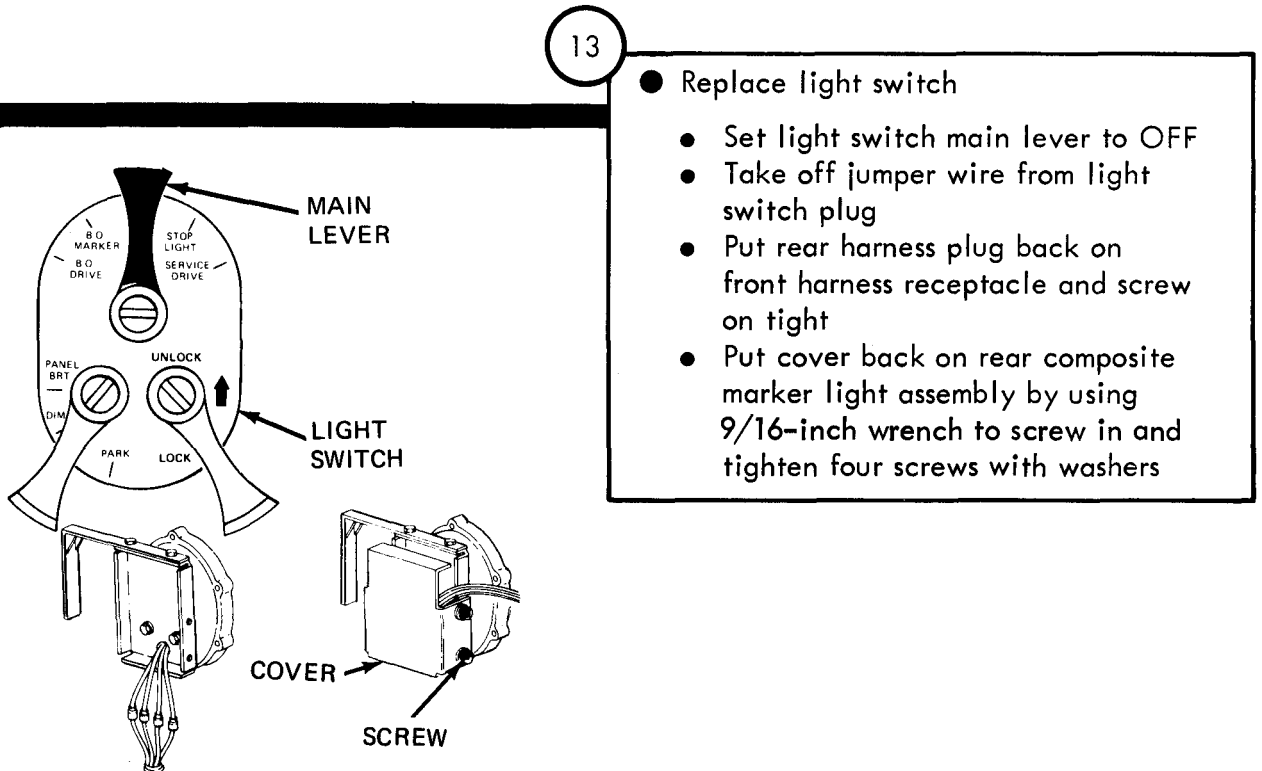
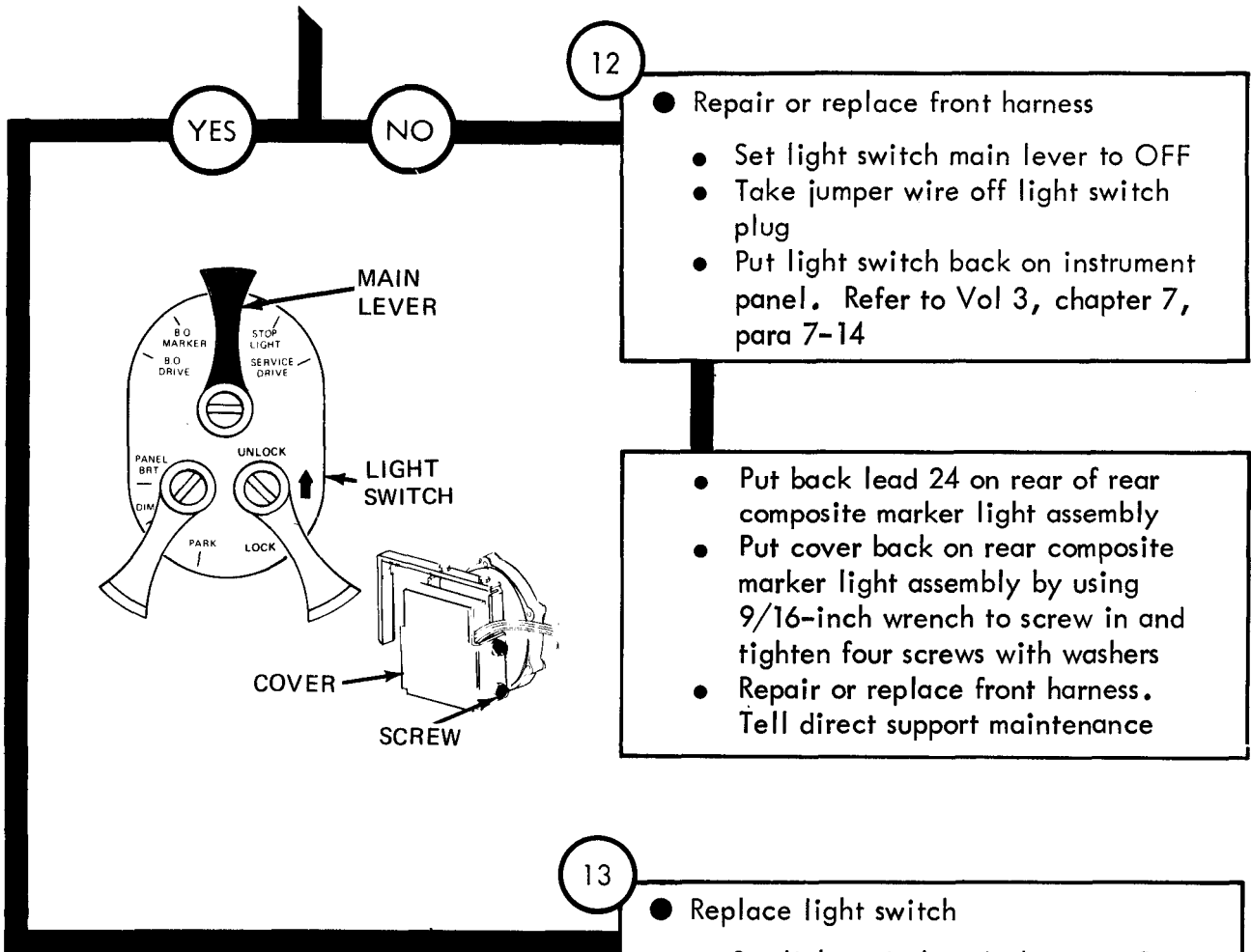

Symptom

17

ONE LAMP DIM, FLICKERING, OR LAMPS THAT WORK SOMETIMES

NOTE

Dim, flickering, or lamps that work sometimes are caused by loose connections, poor ground connections, dirt, paint and corrosion buildup. Finding a fault and correction consists of checking electrical connections for defects, and cleaning and tightening as necessary. A typical lamp, the blackout drive lamp, is used as an example. Other truck lamps can be done the same way

1

- Park truck
- Refer to TM 9-2320-209-10

2

- Remove blackout headlight lamp and circuit 19 lead
 - Take lead 19 from blackout headlight lamp housing connector. Refer to Vol 3, chapter 7, para 7-21 or 7-22
 - Remove blackout headlight lamp from lamp housing. Refer to Vol 3, chapter 7, para 7-23

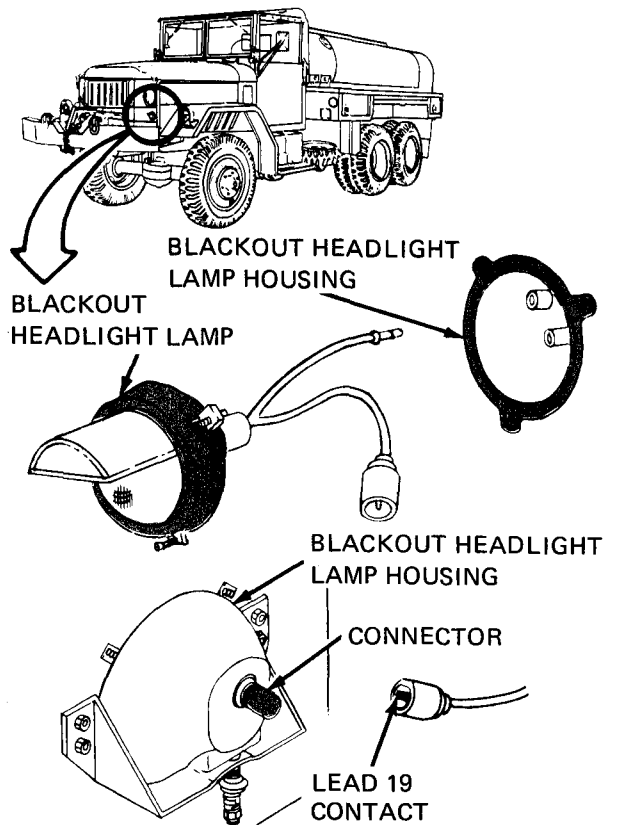

GO

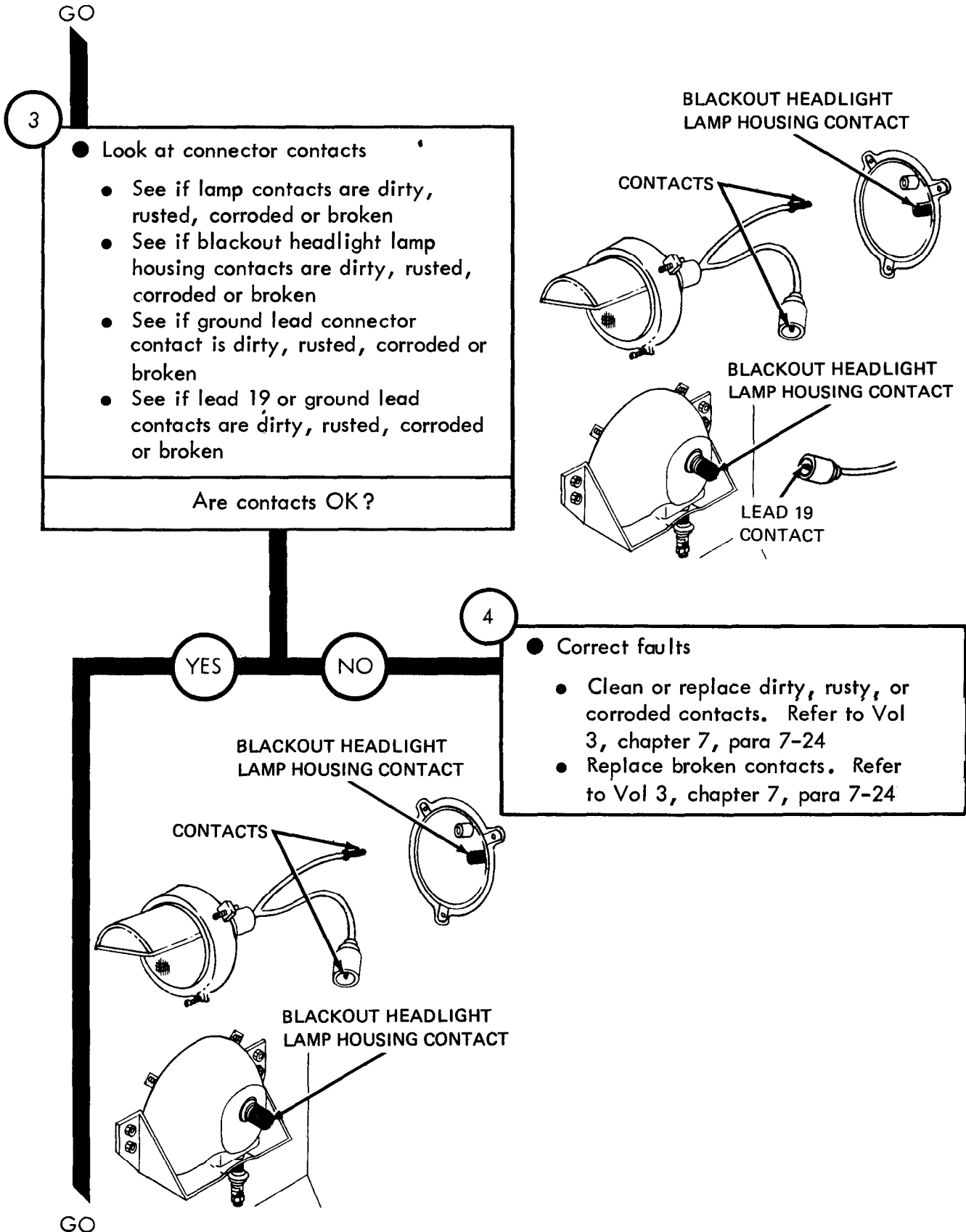

GO

5

- Check connector contacts for tightness
 - Check all connector contacts from housing for tightness. Refer to Vol 3, chapter 7, para 7-24
 - Replace any loose contacts. Refer to Vol 3, chapter 7, para 7-24
 - Check connector contacts from blackout service lamp
 - If contacts are loose, replace lamp. Refer to Vol 3, chapter 7, para 7-24

6

- Check lead 19 contact D connection at light switch
 - Take off light switch from instrument panel. Refer to Vol 3, chapter 7, para 7-14
 - Take off light switch plug from light switch. Refer to Vol 3, chapter 7, para 7-14
 - Make sure contact D in light switch and light switch plug are not dirty, damaged, or corroded
 - Make sure contacts fit together tightly

Are contacts OK?

GO

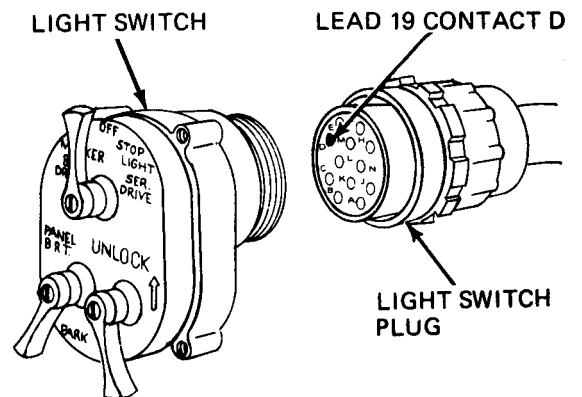

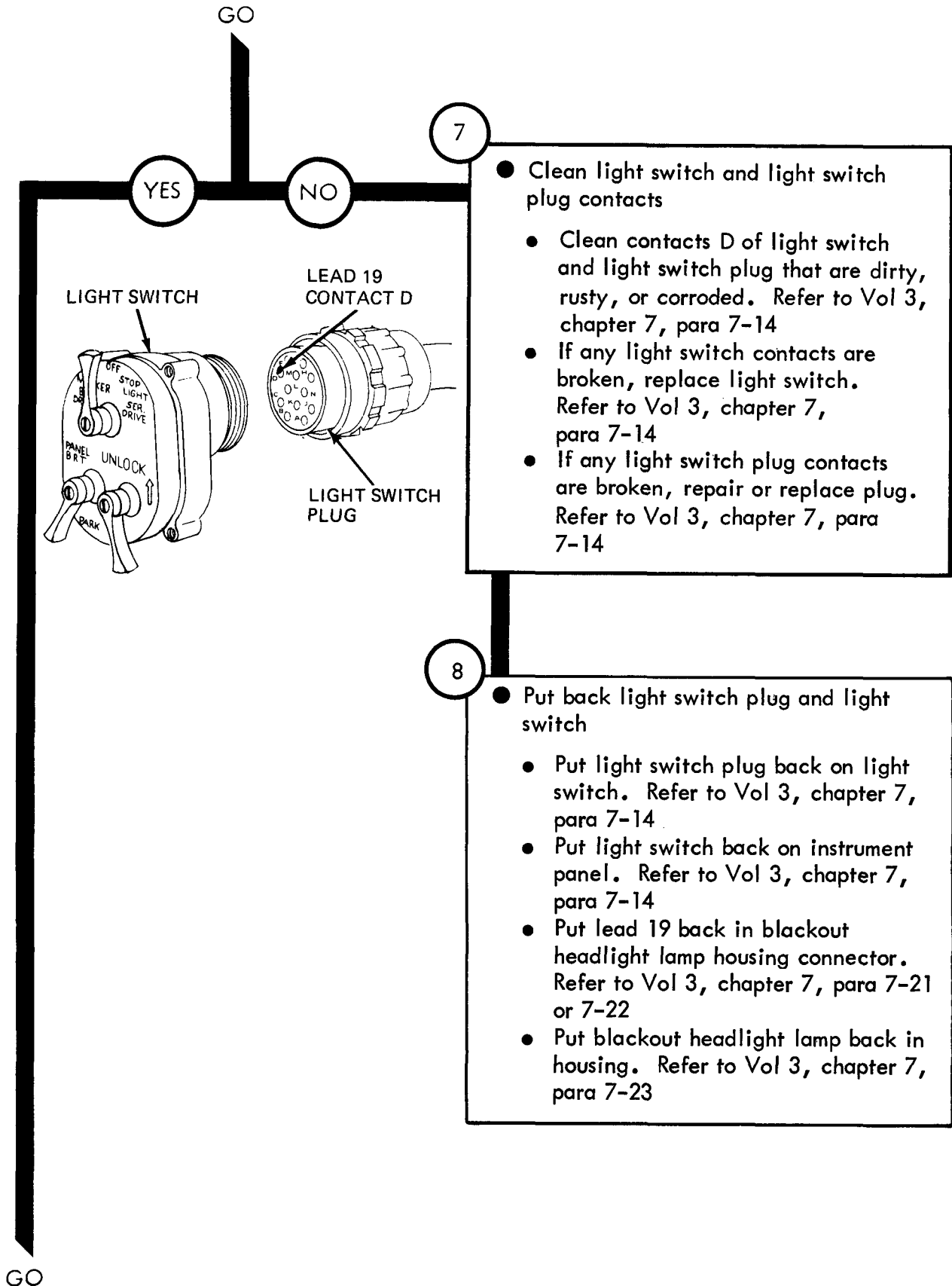

- Clean light switch and light switch plug contacts
 - Clean contacts D of light switch and light switch plug that are dirty, rusty, or corroded. Refer to Vol 3, chapter 7, para 7-14
 - If any light switch contacts are broken, replace light switch. Refer to Vol 3, chapter 7, para 7-14
 - If any light switch plug contacts are broken, repair or replace plug. Refer to Vol 3, chapter 7, para 7-14

- Put back light switch plug and light switch
 - Put light switch plug back on light switch. Refer to Vol 3, chapter 7, para 7-14
 - Put light switch back on instrument panel. Refer to Vol 3, chapter 7, para 7-14
 - Put lead 19 back in blackout headlight lamp housing connector. Refer to Vol 3, chapter 7, para 7-21 or 7-22
 - Put blackout headlight lamp back in housing. Refer to Vol 3, chapter 7, para 7-23

GO

9

- Put back light switch plug and light switch
- Put light switch plug back on light switch. Refer to Vol 3, chapter 7, para 7-14
- Put light switch back on instrument panel. Refer to Vol 3, chapter 7, para 7-14
- Put lead 19 back in blackout headlight lamp housing connector
- Put blackout head light lamp back in housing. Refer to Vol 3, chapter 7, para 7-23

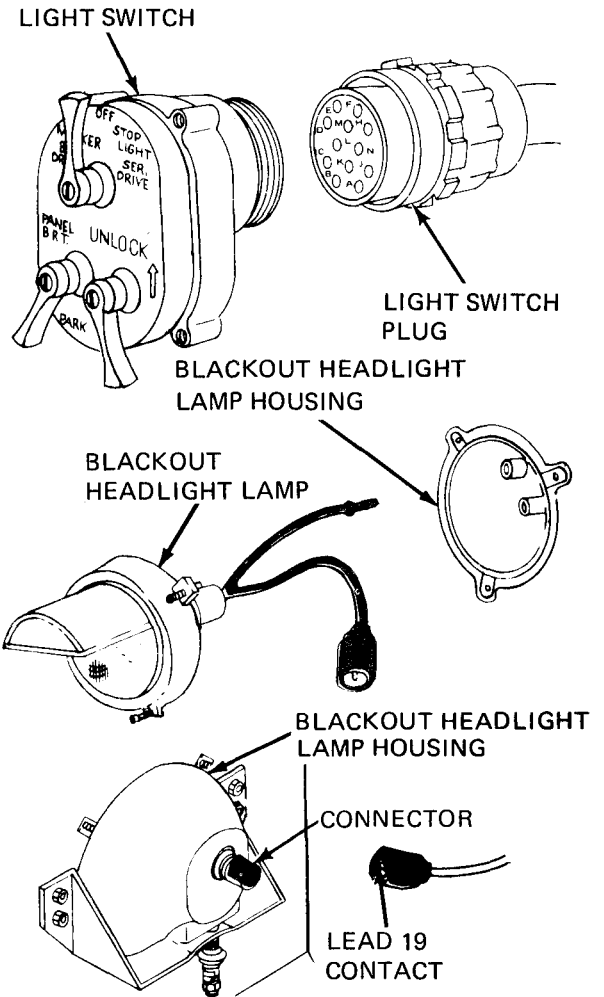

Symptom

18

ALL OR MANY TRUCK RUNNING LIGHTS DIM, FLICKERING, OR WORK SOMETIMES

NOTE

When many truck lamps are dim, flickering or work sometimes the cause is probably loose, broken, dirty, rusty or corroded circuit or ground connections. The fault can usually be found in a circuit between the battery system and light circuit.

1

- Park truck
- Refer to TM 9-2320-209-10

2

- Check battery system
 - Refer to figure 29-1
- Is battery system OK?

GO

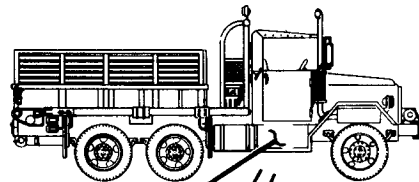

BATTERY BOX

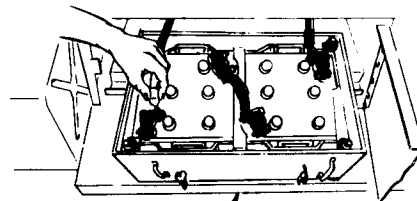

BATTERIES

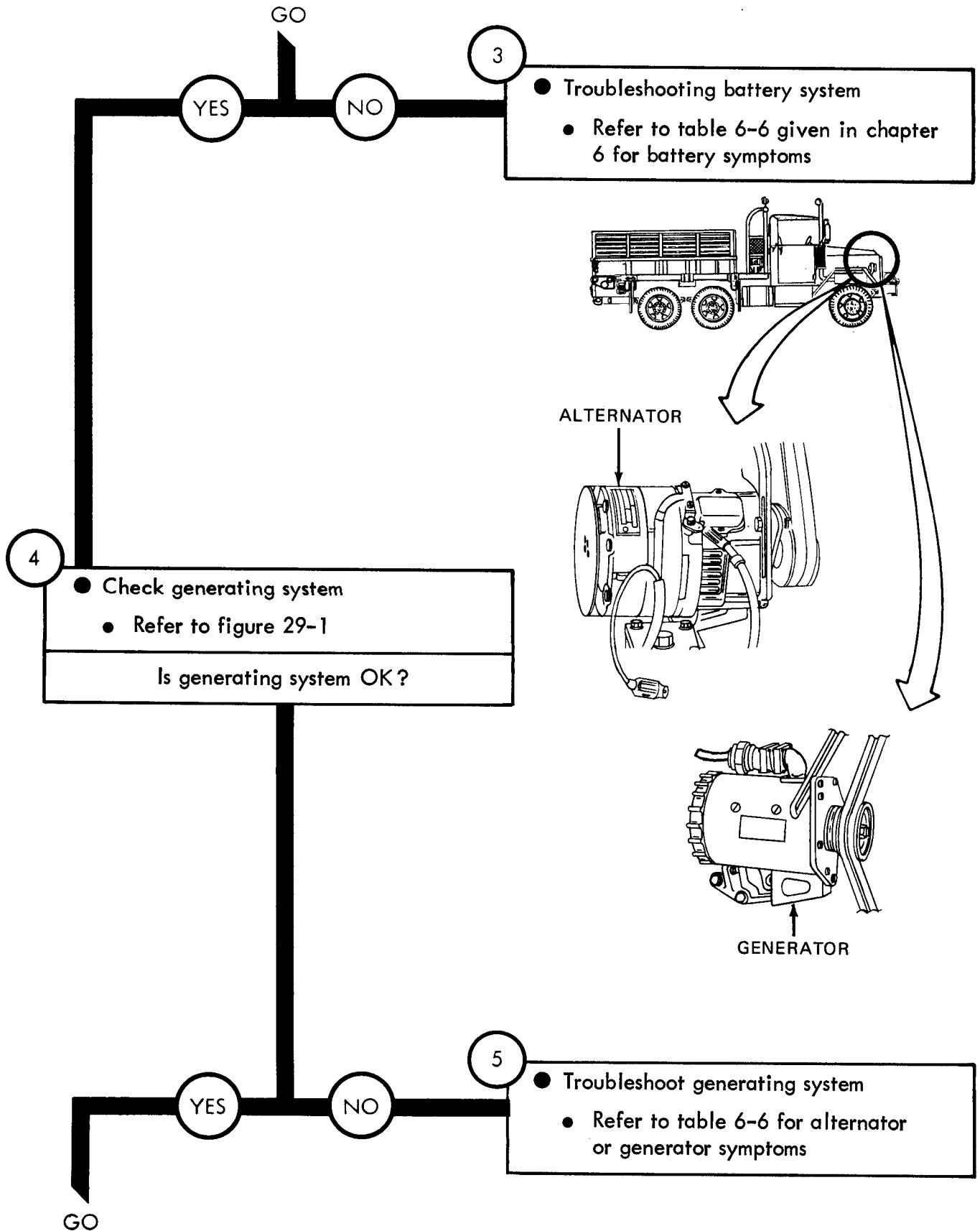

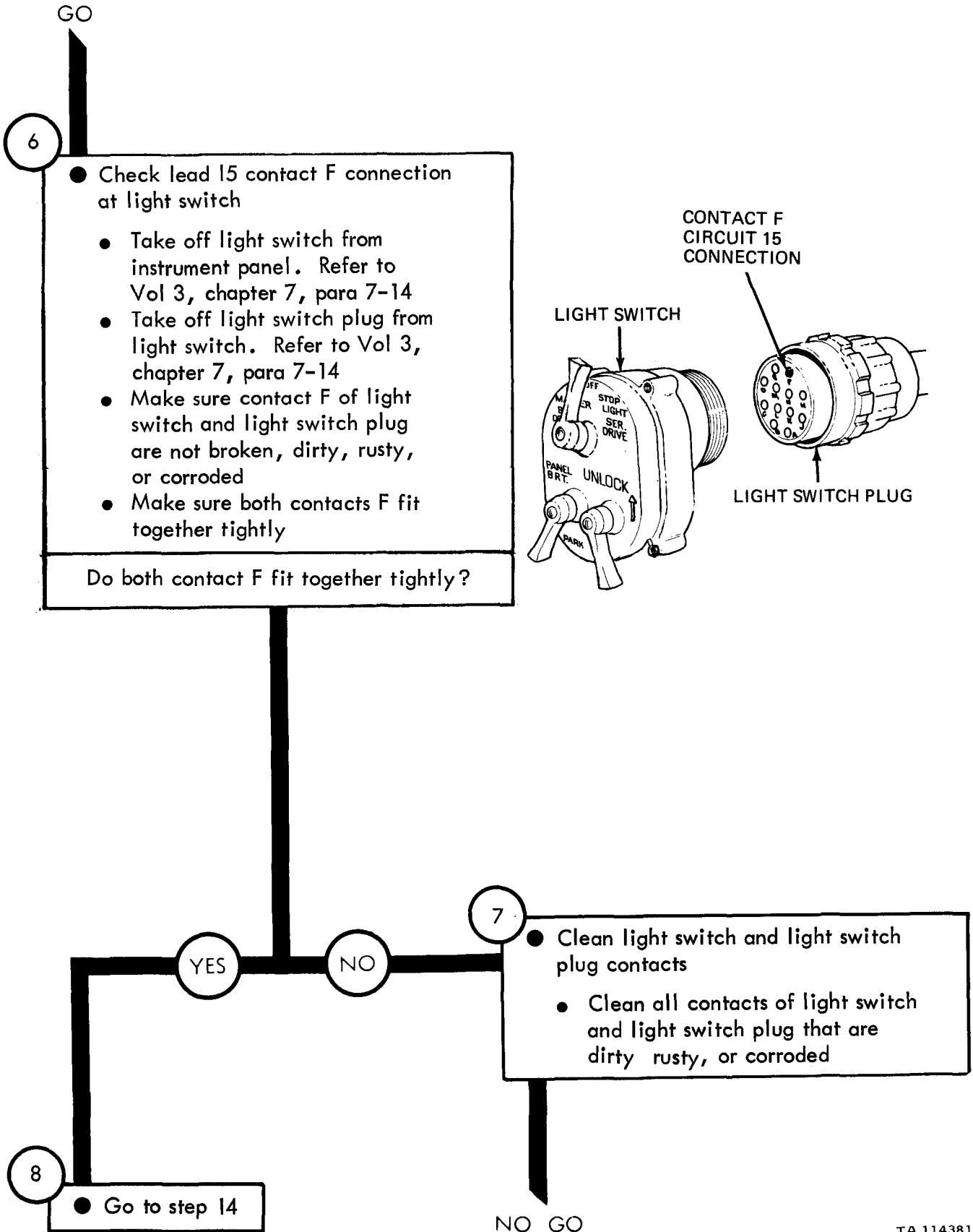

TA 114381

NO GO

9

- See if lamps are still dim, flickering, or work sometimes
 - Put light switch plug back on light switch. Refer to Vol 3, chapter 7, para 7-14
 - Put light switch back on instrument panel. Refer to Vol 3, chapter 7, para 7-14
 - Set light switch main lever to position you found dim, flickering, or lamps that work sometimes
 - Look at lamps and see if they are still dim, flickering or work sometimes

Are lamps dim, flickering or work sometimes?

MAIN LEVER

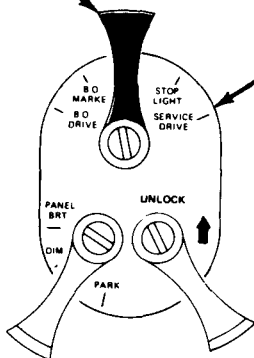

LIGHT SWITCH

NO

10

- Troubleshooting completed
- Set light switch main lever to OFF

NO GO

TA 114382

Figure 25-18 (Sheet 4 of 8)

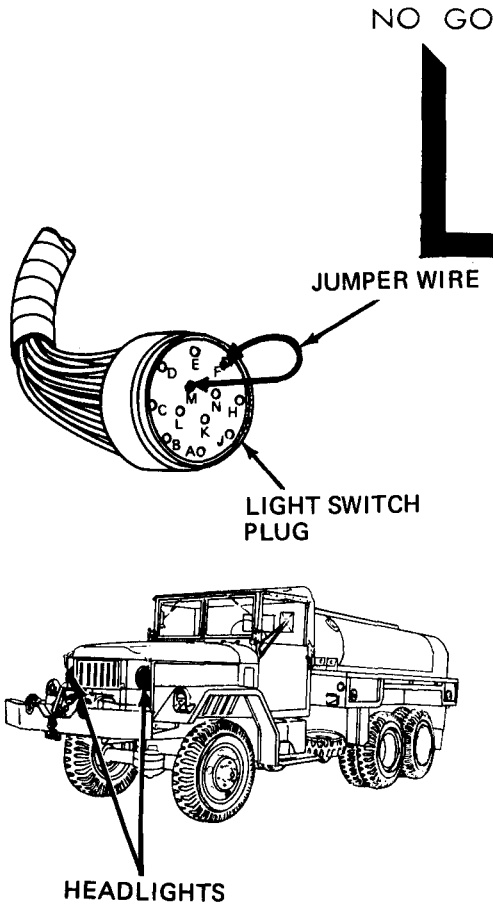

YES

11

- Check light switch
 - Take off light switch from instrument panel. Refer to Vol 3, chapter 7, para 7-14
 - Take light switch plug from light switch. Refer to Vol 3, chapter 7, para 7-14
 - Put jumper wire between contact E and the contact M for a bad headlight lamp
 - Look at headlight lamps and see if lamp is still dim, flickering, or work sometimes

Is lamp dim, flickering, or work sometimes?

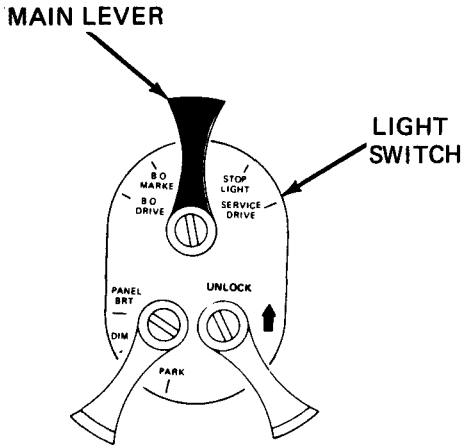

NO

12

- Replace light switch
 - Take jumper wire off light switch plug
 - Replace light switch. Refer to Vol 3, chapter 7, para 7-14

NO GO

Figure 25-18 (Sheet 5 of 8)

NO GO

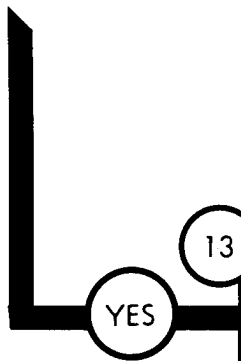

YES

13

- Repair or replace front harness
- Take jumper wire off light switch plug
- Repair or replace front harness. Tell direct support maintenance

From step 8

14

- See if lamps are still dim, flickering, or working sometimes
- Put light switch plug back on light switch. Refer to Vol 3, chapter 7, para 7-14
- Put light switch back on instrument panel. Refer to Vol 3, chapter 7, para 7-14
- Set light switch main lever to position you found dim, flickering, or lamps that work sometimes
- Look at lamps and see if they are still dim, flickering, or working sometimes

Are lamps dim, flickering, or work sometimes?



GO

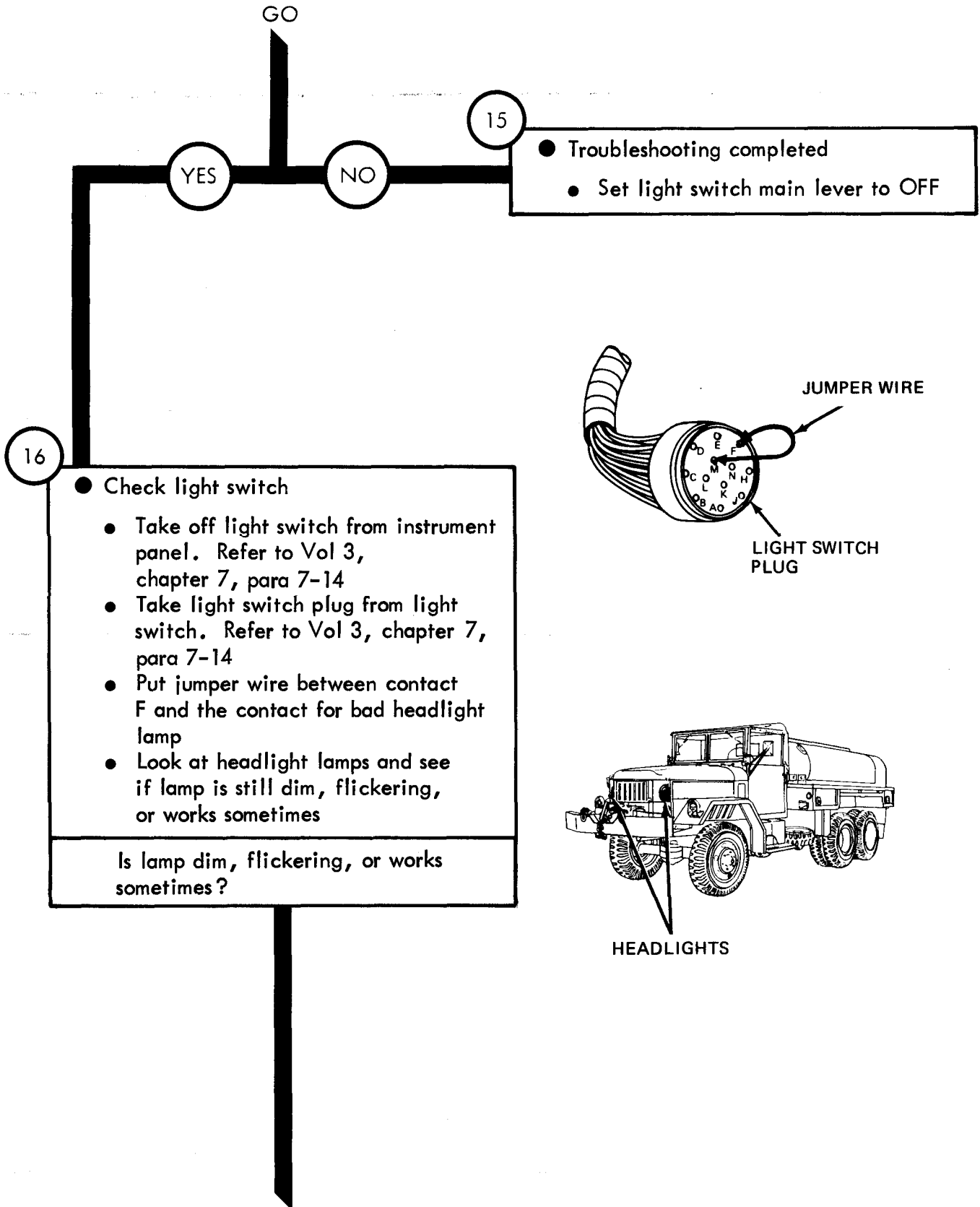

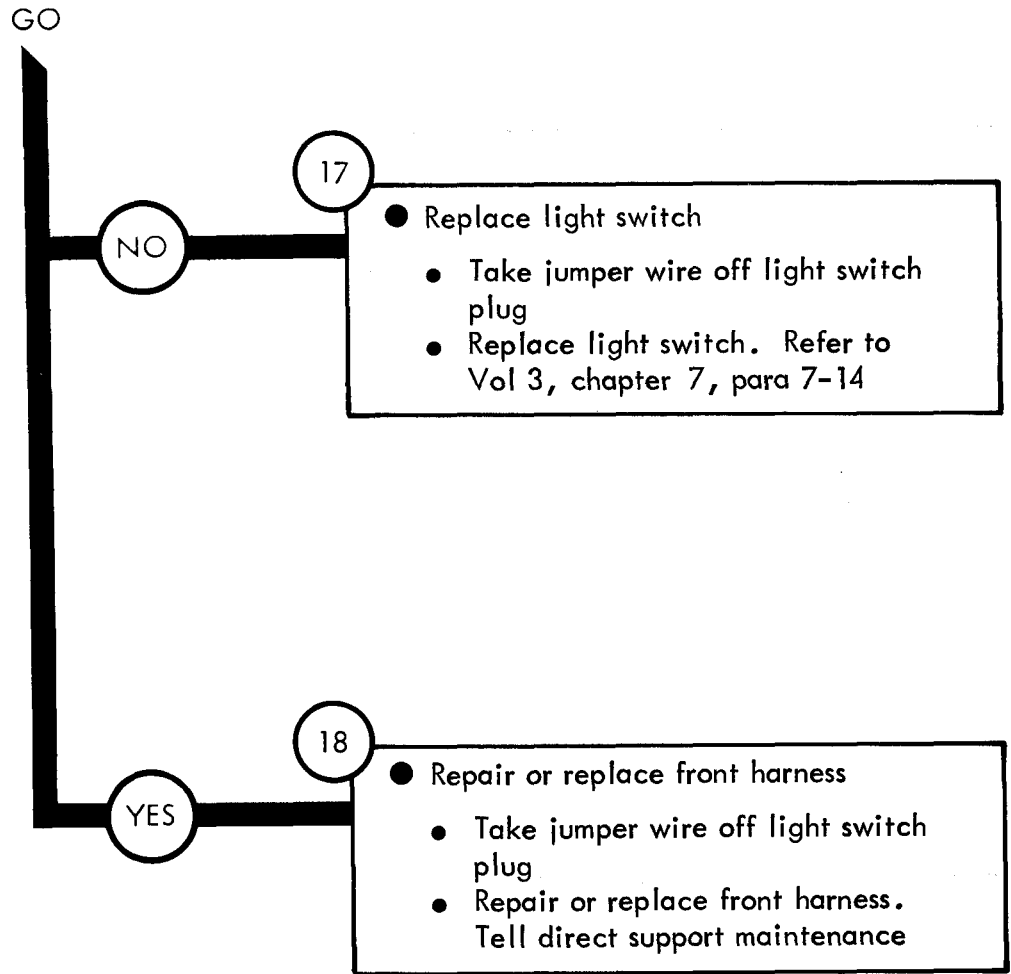

Symptom

19

LAMPS BURN OUT TOO OFTEN

NOTE

Short lamp life is caused by generating voltage that is too high, loose lamp housings, or loose mountings. Loose lamp mountings or housings vibrate, which breaks lamp filaments

1

- Park truck
- Refer to TM 9-2320-209-10

2

- Check generating subsystem for +26.8 volts DC to +28.2 volts DC output
 - Start engine. Refer to TM 9-2320-209-10
 - Pull out battery box. Refer to Vol 3, chapter 7, para 7-55
 - Set multimeter to measure +28.2 volts DC. Refer to test equipment procedures index
 - Put multimeter + lead on battery + terminal. Put multimeter - lead on battery - terminal
 - Read multimeter

Does multimeter measure +26.8 volts DC to +28.2 volts DC?

GO

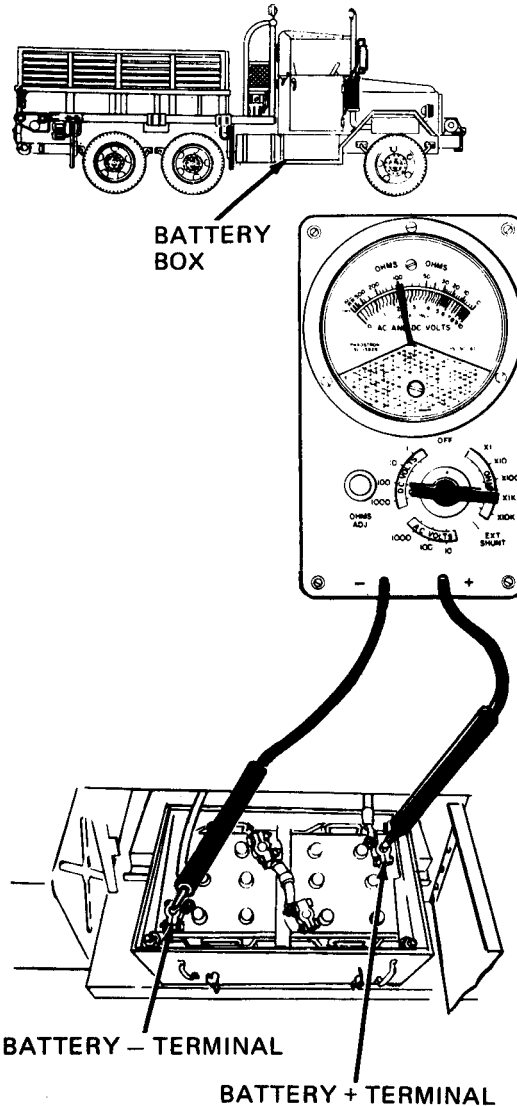

TA 114387

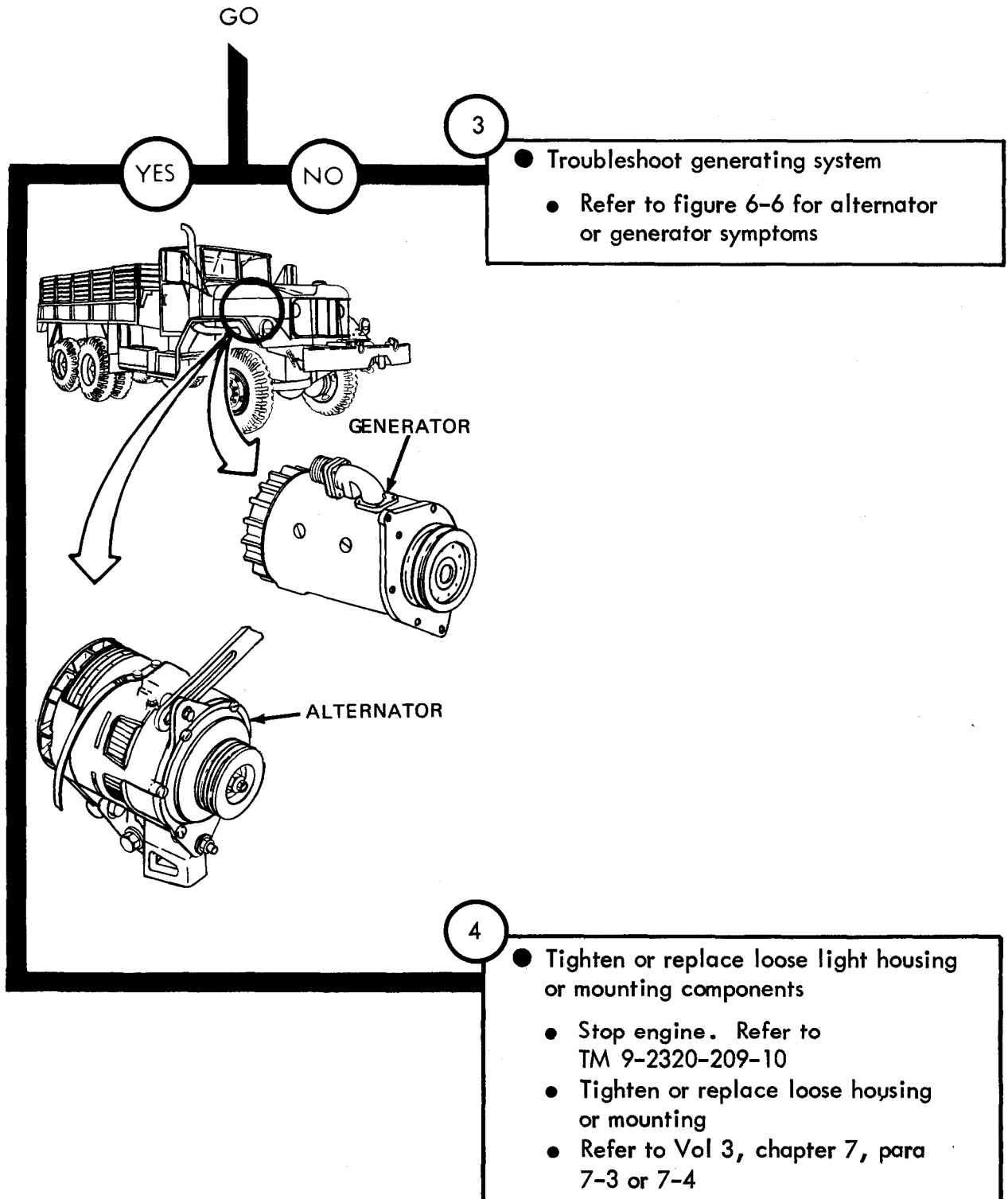

Symptom

20 ALL OR MANY TRUCK RUNNING LIGHTS DO NOT LIGHT

NOTE

When checking voltage, +24 volts DC means a range of +23 volts DC to +26 volts DC

1

- Park truck
 - Refer to TM 9-2320-209-10

2

- Check light switch input voltage
 - Take off light switch from instrument panel. Refer to Vol 3, chapter 7, para 7-14
 - Take off light switch plug from light switch. Refer to Vol 3, chapter 7, para 7-14

- Set multimeter to measure +24 volts DC. Refer to test equipment procedures index
- Put multimeter - lead on a good ground
- Put multimeter + lead on contact F of light switch plug
- Read multimeter. Multimeter should measure +24 volts DC

Does multimeter measure less than +24 volts DC?

GO

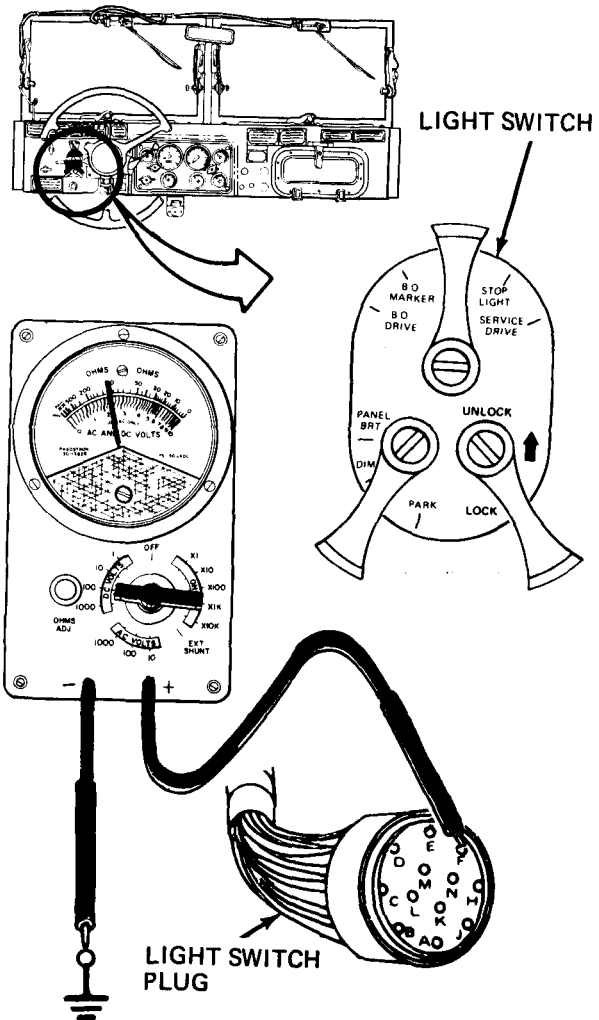

TA 114389

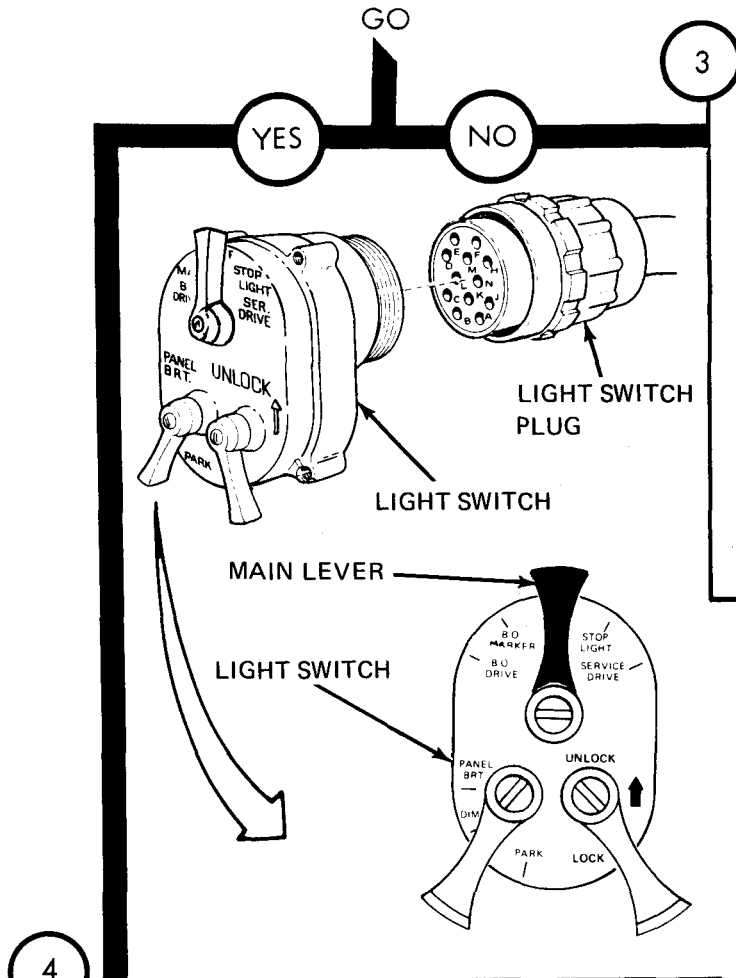

3

- Troubleshoot truck running lights that do not light
 - Put light switch plug back on light switch. Refer to Vol 3, chapter 7, para 7-14
 - Put light switch back on instrument panel. Refer to Vol 3, chapter 7, para 7-14
 - Make sure light switch main lever is set to OFF
 - Troubleshoot truck running lights that do not light. Refer to troubleshooting index

4

- Check for shorts at light switch plug
 - Set multimeter to test for shorts. Refer to test equipment procedures index
 - Put multimeter - lead on a good ground
 - Put multimeter + lead on each plug contact, one contact at a time. Read multimeter for each contact. Always keep multimeter - lead on a good ground
 - Read multimeter. Multimeter pointer should not move

Does multimeter pointer stay still for each test?

GO

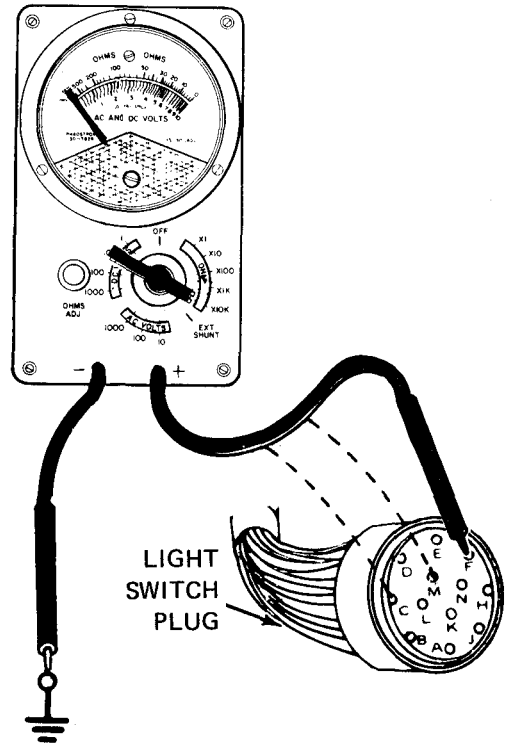
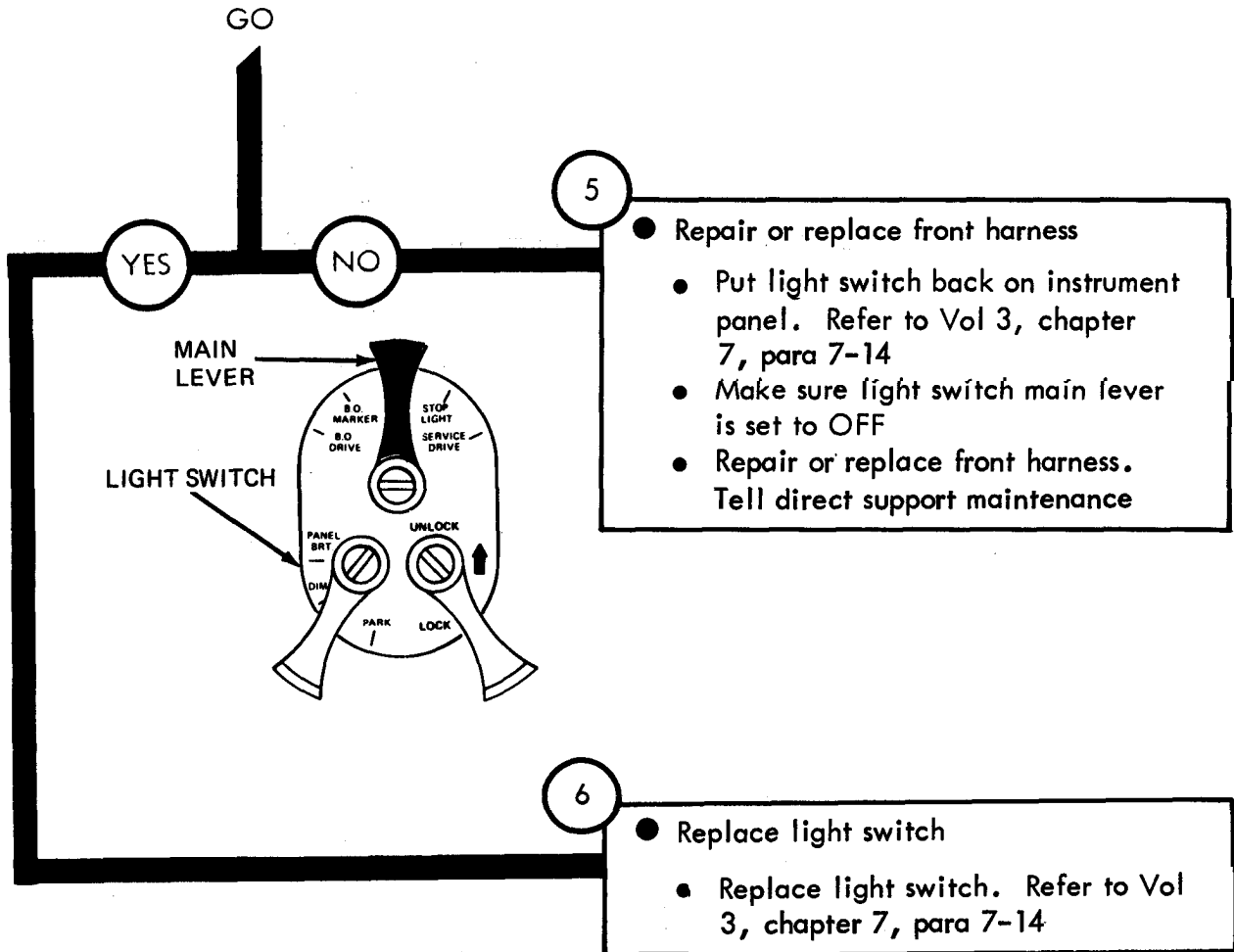

Figure 25-20 (Sheet 2 of 3)



Symptom

21

ONE OR MORE TRAILER SERVICE OR BLACKOUT STOP LIGHTS DO NOT LIGHT, ALL TRUCK RUNNING LIGHTS LIGHT

NOTE

Two soldiers are needed to do this troubleshooting. SOLDIER A sits in the cab and operates controls. SOLDIER B makes voltage checks with the multimeter. These steps are the same for all trailer stoplights that do not light

When checking voltage, +24 volts DC means a range of +23 volts DC to +26 volts DC

1

- Park truck
- Refer to TM 9-2320-209-10

GO

GO

- 2
- Check for voltage to trailer service or blackout stoplight that does not light
- SOLDIER B: ● Take off trailer connecting cable from trailer
- SOLDIER A: ● Set light switch main lever to SERVICE DRIVE OR BLACKOUT DRIVE for trailer stoplight that does not light
- SOLDIER B: ● Set multimeter to measure +24 volts DC. Refer to test equipment procedures index

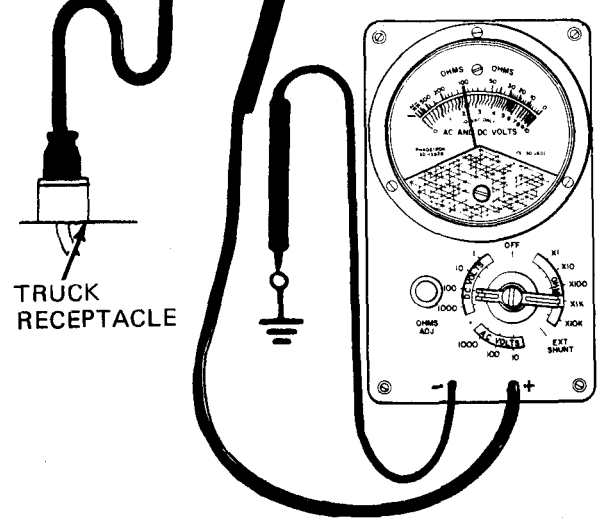
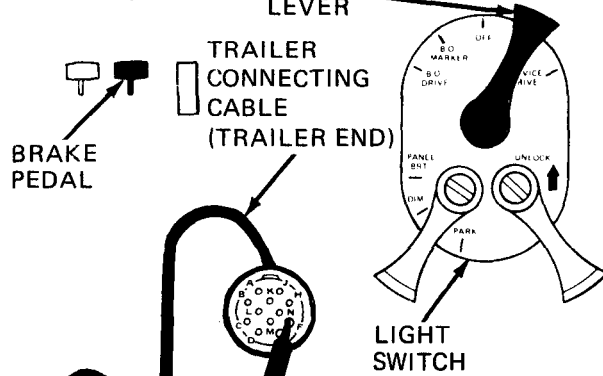
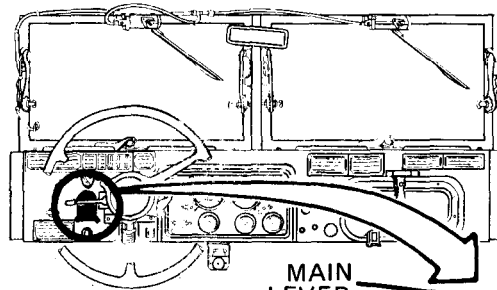
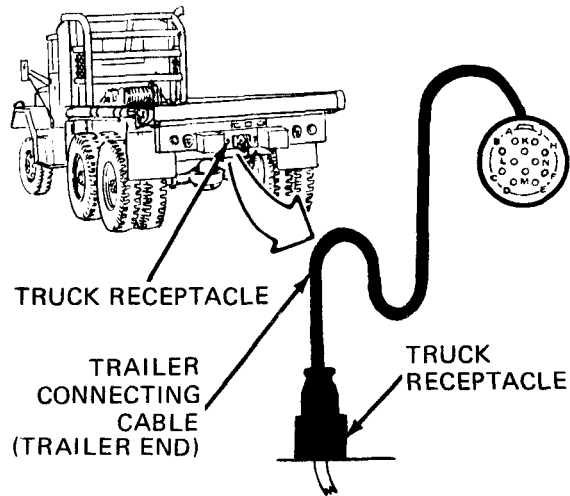

- SOLDIER B: ● Put multimeter - lead on a good ground
- Put multimeter + lead on contact of plug for light that does not light. J=RH service stoplight, B=LH service stoplight, or F= blackout stoplight
- SOLDIER A: ● Step on brake pedal and hold it down
- SOLDIER B: ● Read multimeter while Soldier A steps down on brake pedal. Multimeter should measure +24 volts DC

Does multimeter measure +24 volts DC?

GO

TA 114393

Figure 25-21 (Sheet 2 of 5)

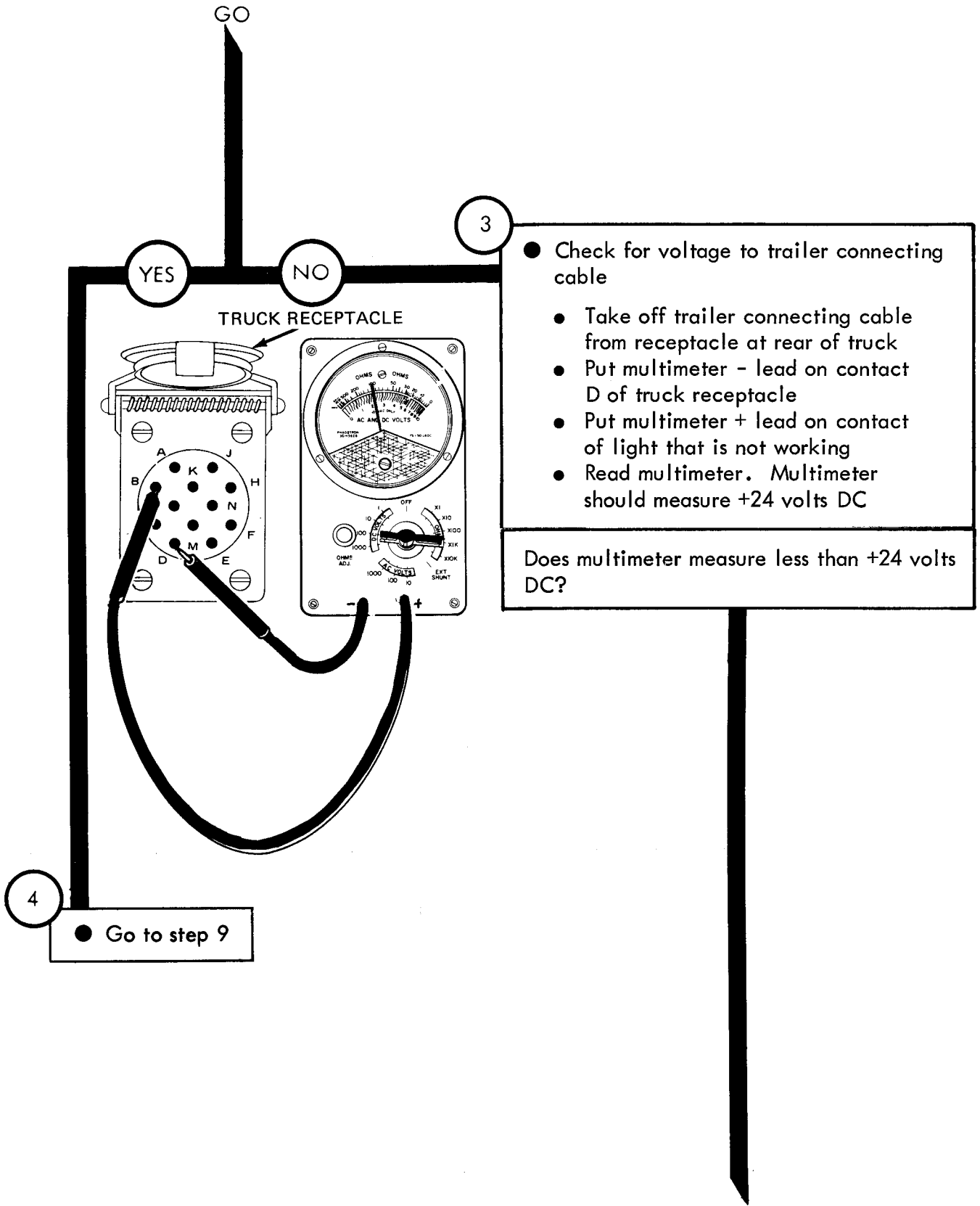

YES

NO

3

- Check for voltage to trailer connecting cable
- Take off trailer connecting cable from receptacle at rear of truck
- Put multimeter - lead on contact D of truck receptacle
- Put multimeter + lead on contact of light that is not working
- Read multimeter. Multimeter should measure +24 volts DC

Does multimeter measure less than +24 volts DC?

4

● Go to step 9

NO GO

TA 114394

Figure 25-21 (Sheet 3 of 5)

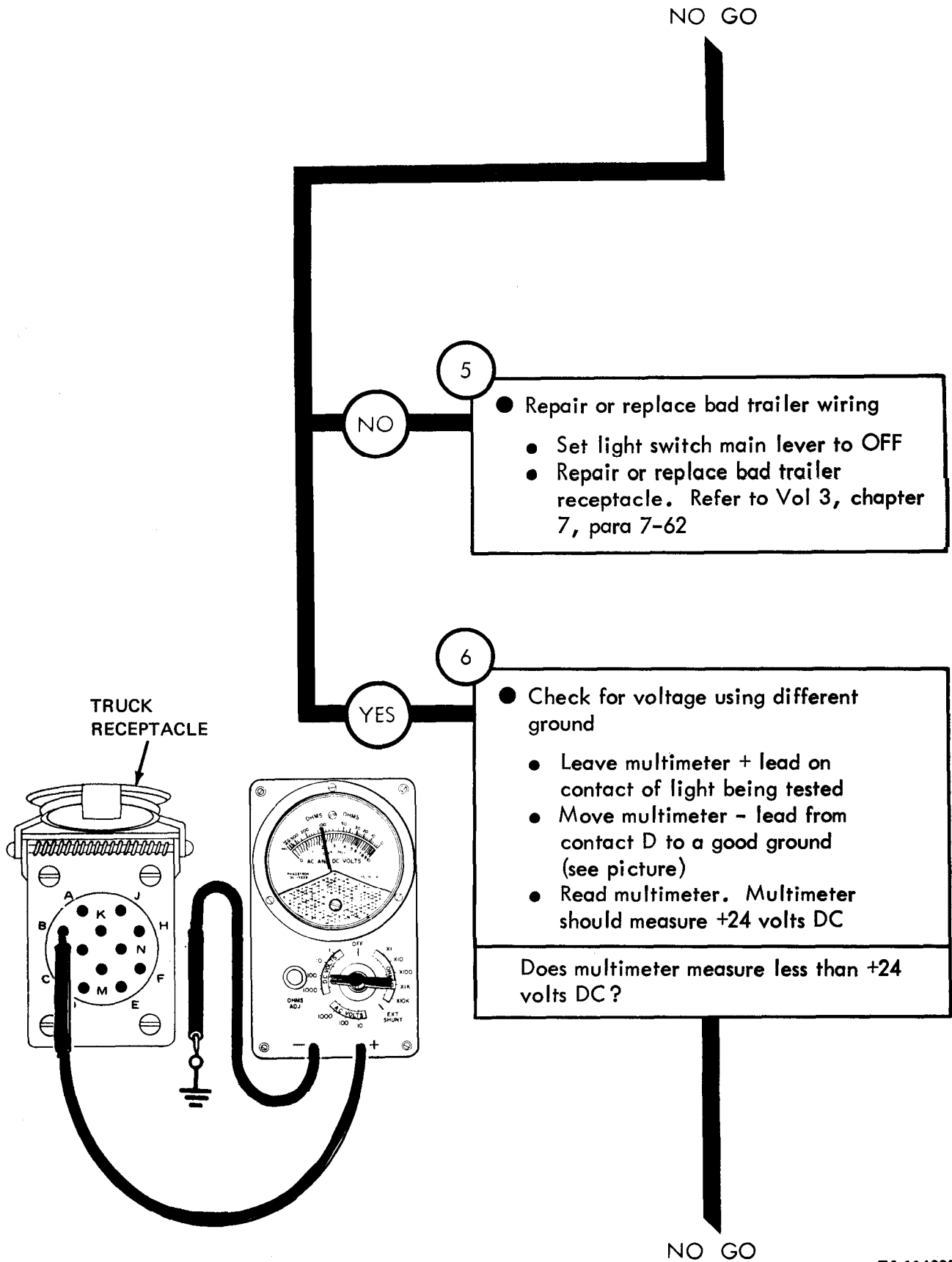

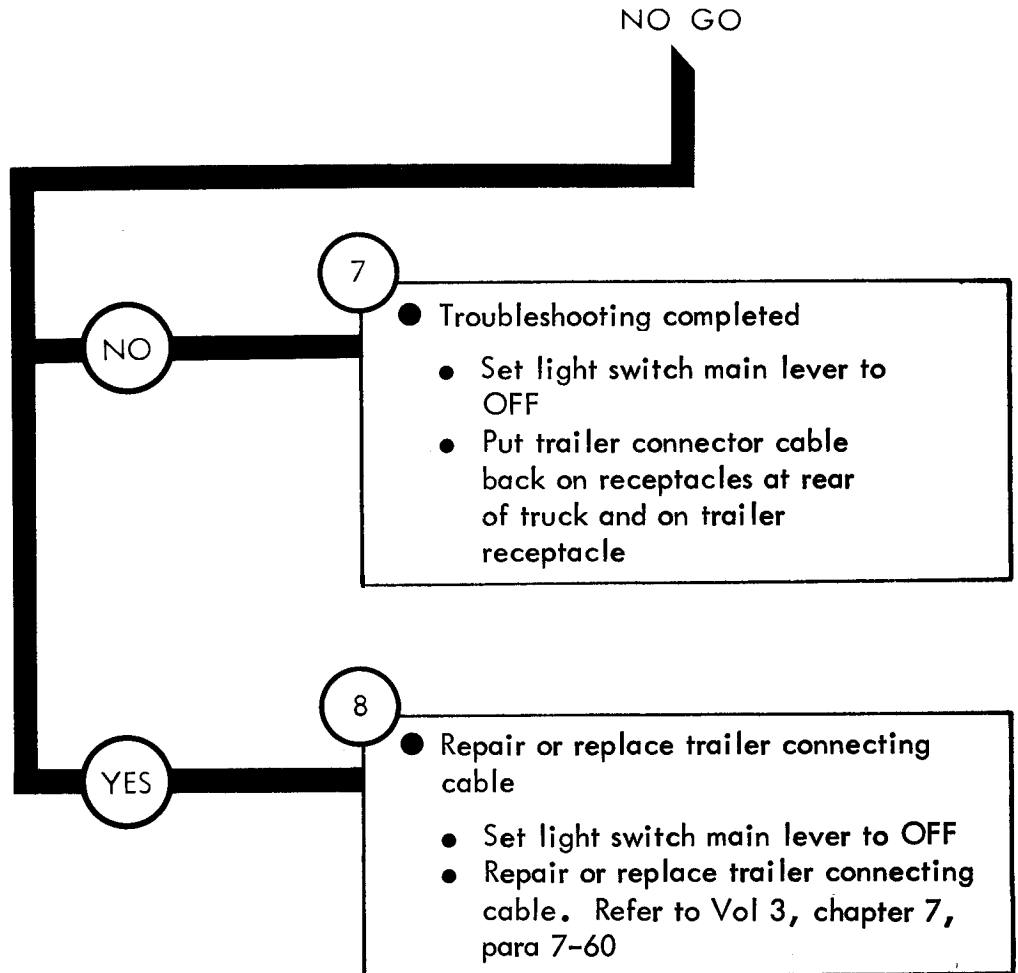

From step 4

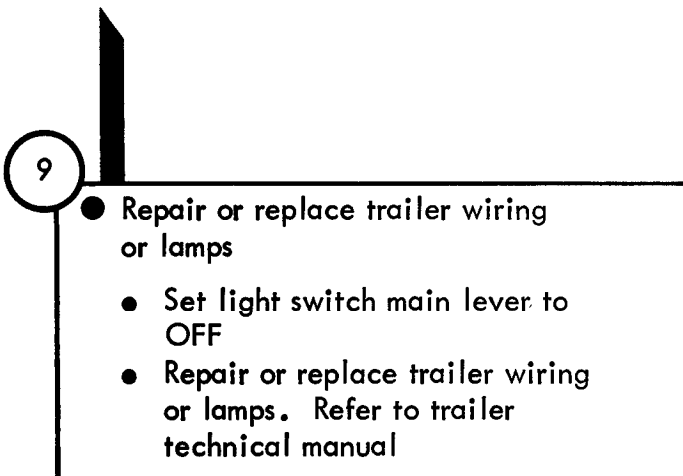

Symptom

22

ONE OR MORE TRAILER LIGHTS DO NOT LIGHT (EXCEPT TRAILER SERVICE AND BLACKOUT STOPLIGHTS) ALL OTHER TRUCK RUNNING LIGHTS LIGHT

NOTE

Two soldiers are needed to do this troubleshooting. Soldier A sits in the cab and operates controls. Soldier B makes voltage checks with the multimeter

Do these steps for each trailer light that does not light

When checking voltage, +24 volts DC means a range of +23 volts DC to +25 volts DC

1

- Park truck
- Refer to TM 9-2320-209-10

GO

GO

2

- Check for voltage to trailer light that does not light

SOLDIER B: ● Take off trailer connector cable from trailer receptacle

SOLDIER A: ● Set light switch main lever to position for trailer light that does not light

SOLDIER B: ● Set multimeter to measure +24 volts DC. Refer to test equipment procedures index

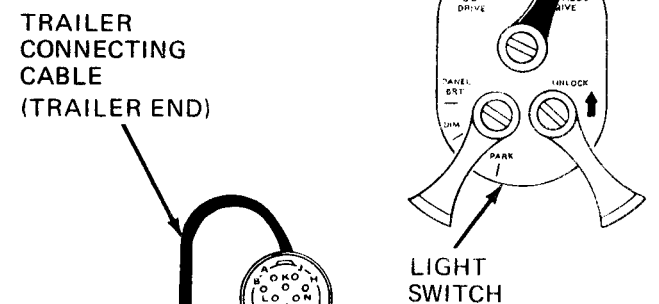
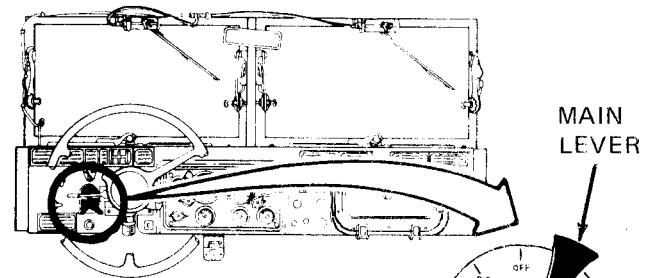
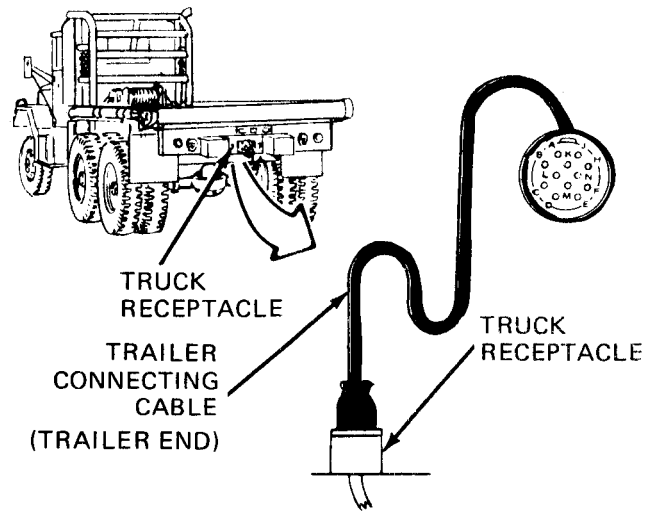

- SOLDIER B: ● Put multimeter - lead on a good ground
- Put multimeter + lead on contact of cable, for light that does not light. Contact A of rear B. O. MARKER (L.H.), contact C for rear B. O. MARKER (R.H.), and contact H for B. O. MARKER lights
 - Read multimeter. Multimeter should measure +24 volts DC

Does multimeter measure +24 volts DC?

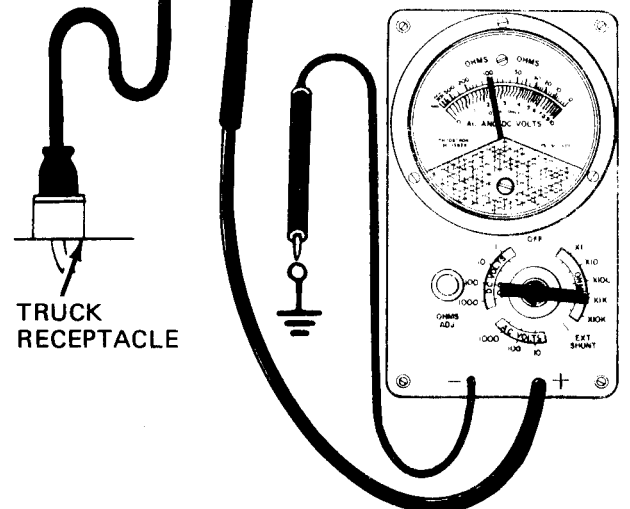

GO

TA 114398

Figure 25-22 (Sheet 2 of 5)

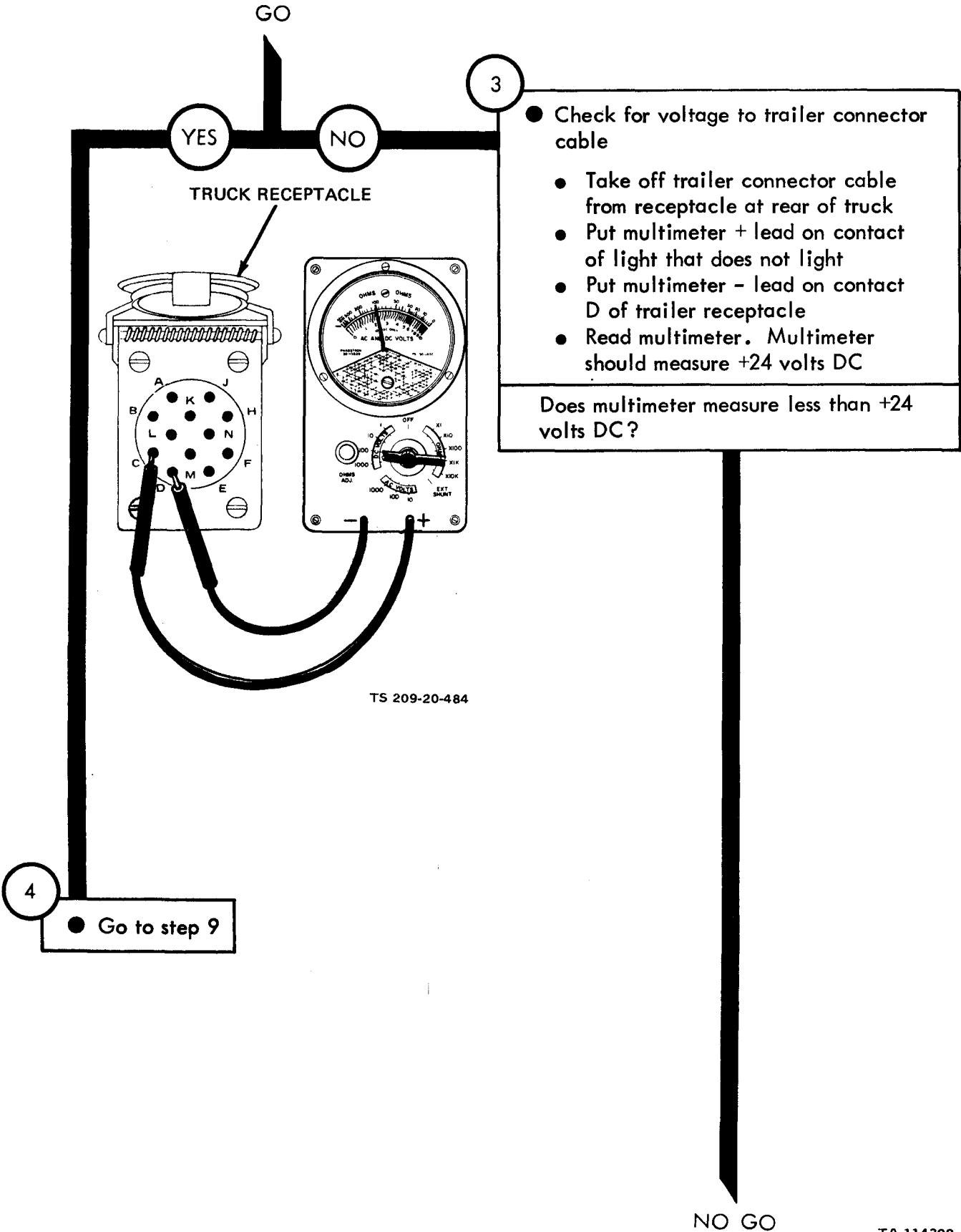

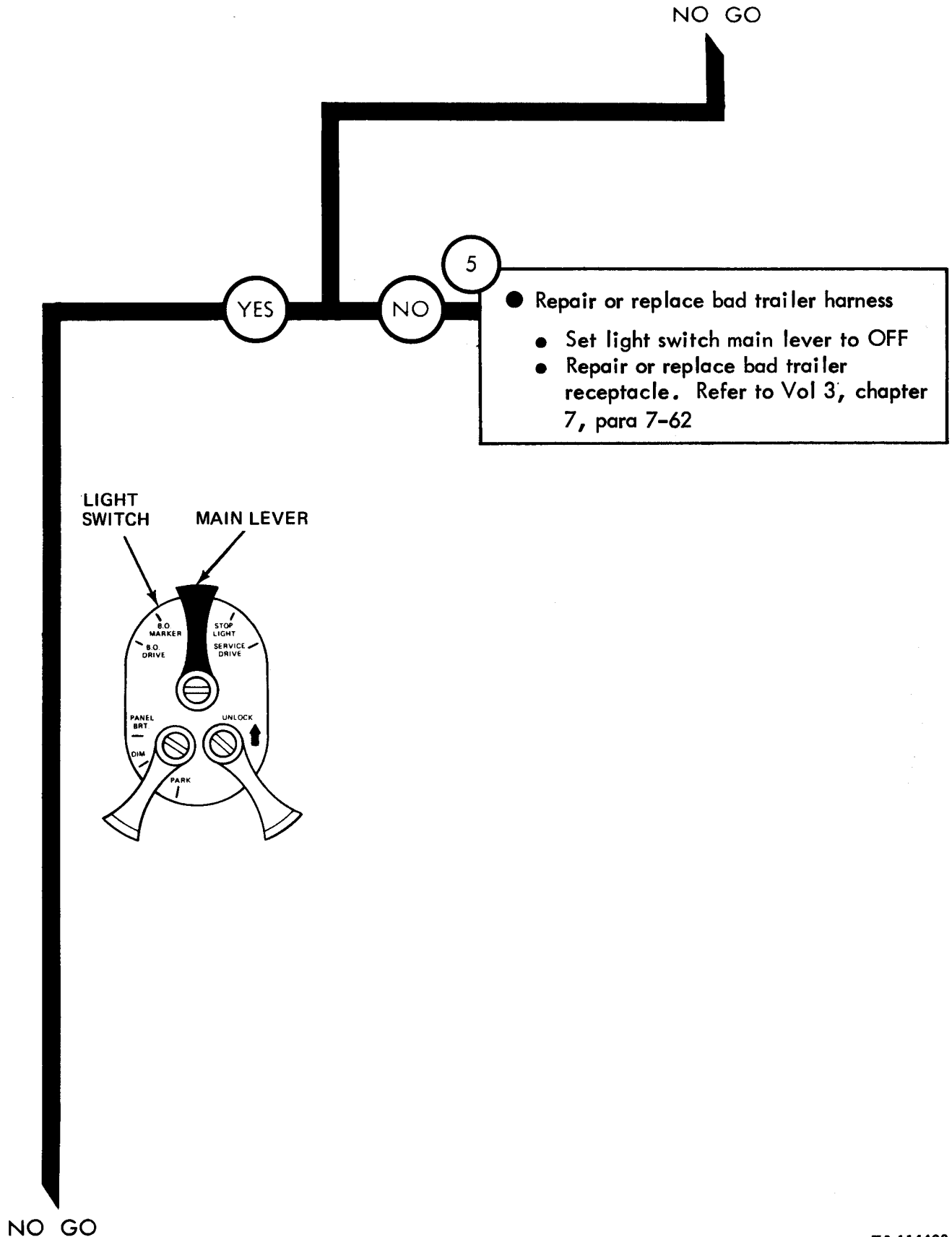

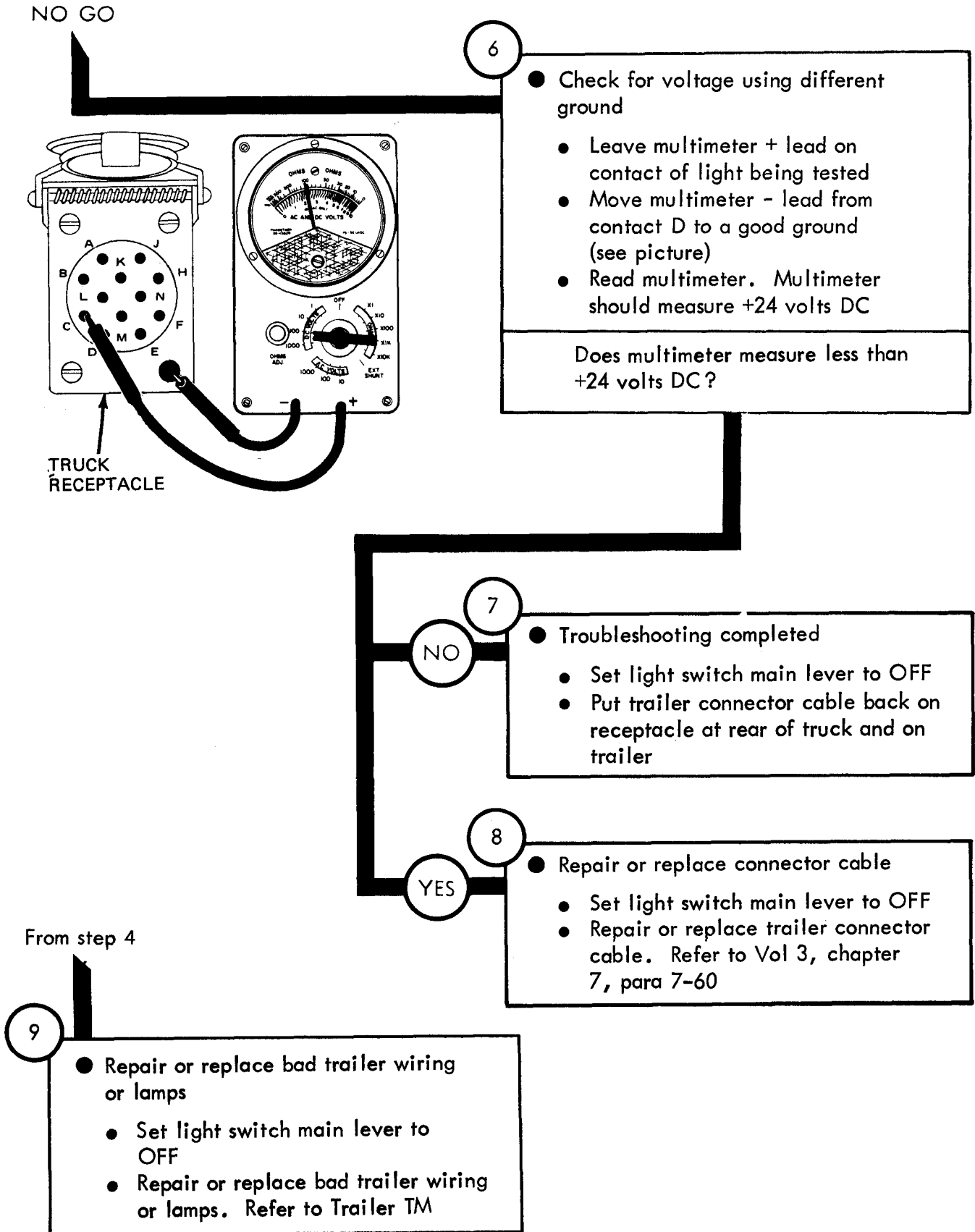

TA 114401

Symptom

23

ONE CONTROL ASSEMBLY DIRECTIONAL SIGNAL LAMP DOES NOT LIGHT

NOTE

When checking ~~voltage, +24 volts DC~~ means a range of ~~+23 to +26 volts DC~~

1

● Park truck

● Refer to TM 9-2320-209-10

2

Is the directional **signa** l lamp that does not light a front lamp?

GO

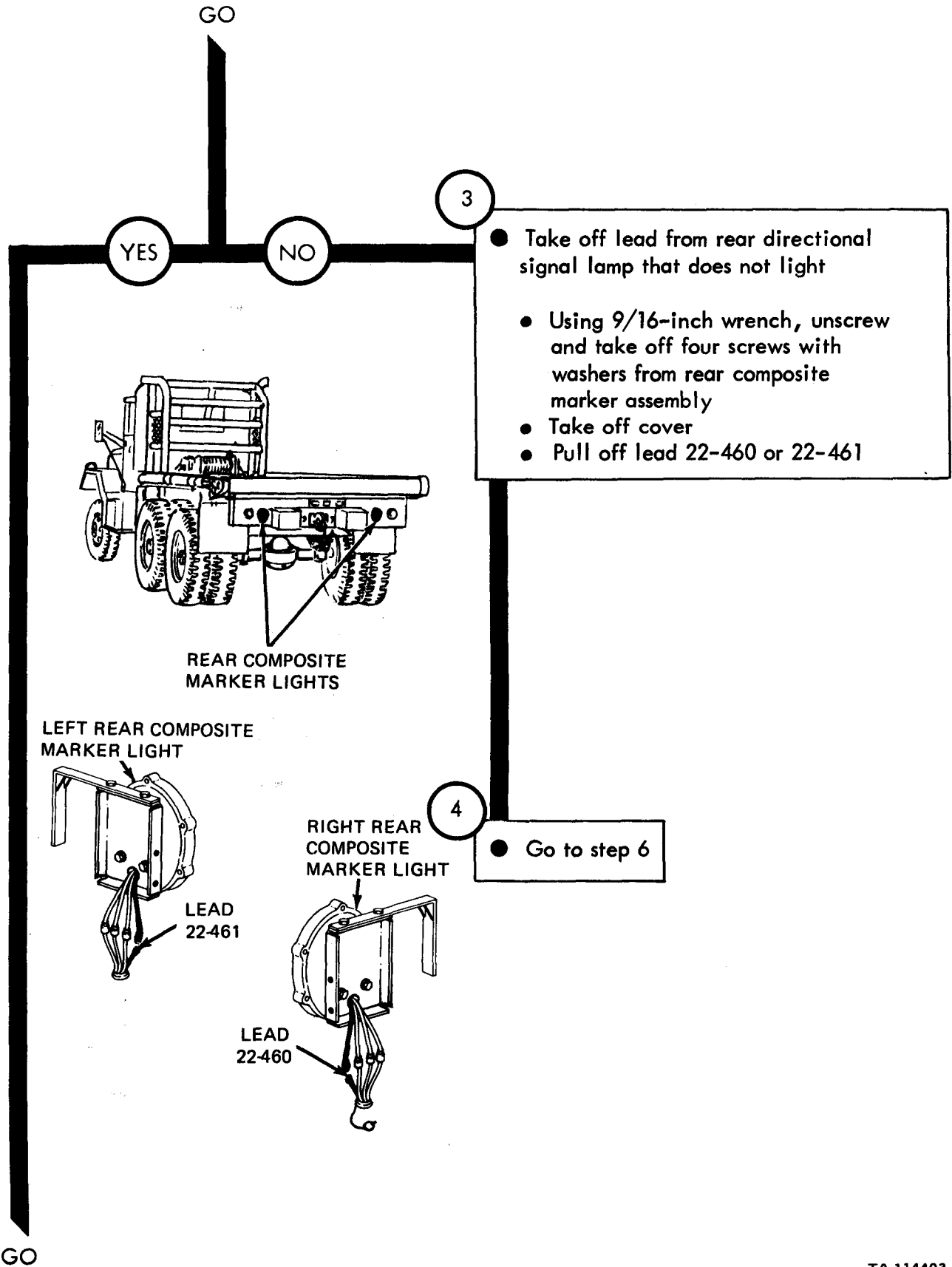

TA 114403

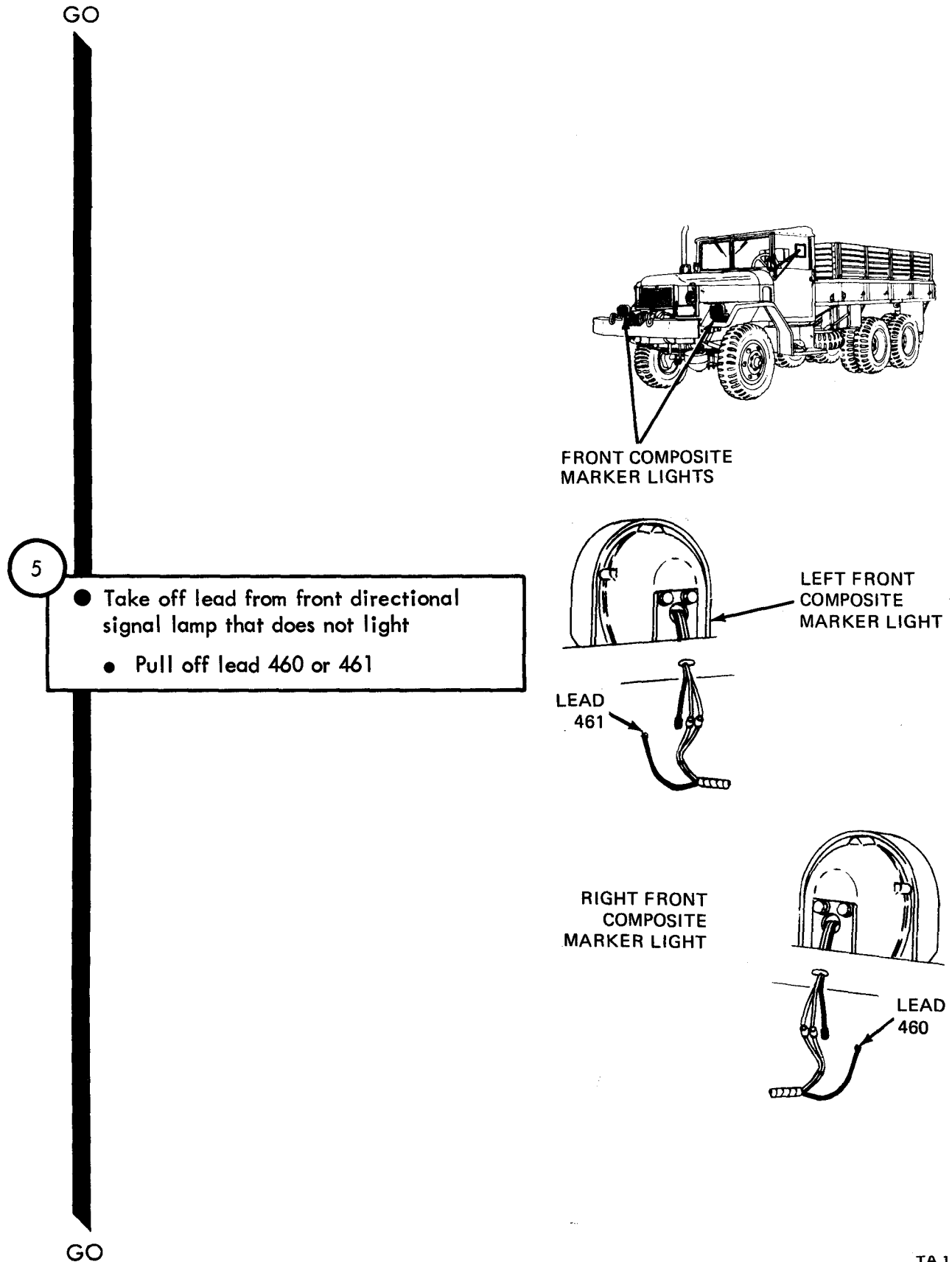

Figure 25-23 (Sheet 3 of 16)

GO

6

- Check for voltage at directional signal lamp that does not light
 - Set light switch main lever to SERVICE DRIVE
 - Set turn signal control lever to emergency flasher position
 - Set multimeter to measure +24 volts DC. Refer to test equipment procedures index
 - Put multimeter - lead on a good ground. Put multimeter + lead on contact of lead 460, 461, 22-460, or 22-461
 - Read multimeter. Multimeter pointer should move up and down scale at rate of 1 to 2 times per second

Is multimeter reading wrong?

GO

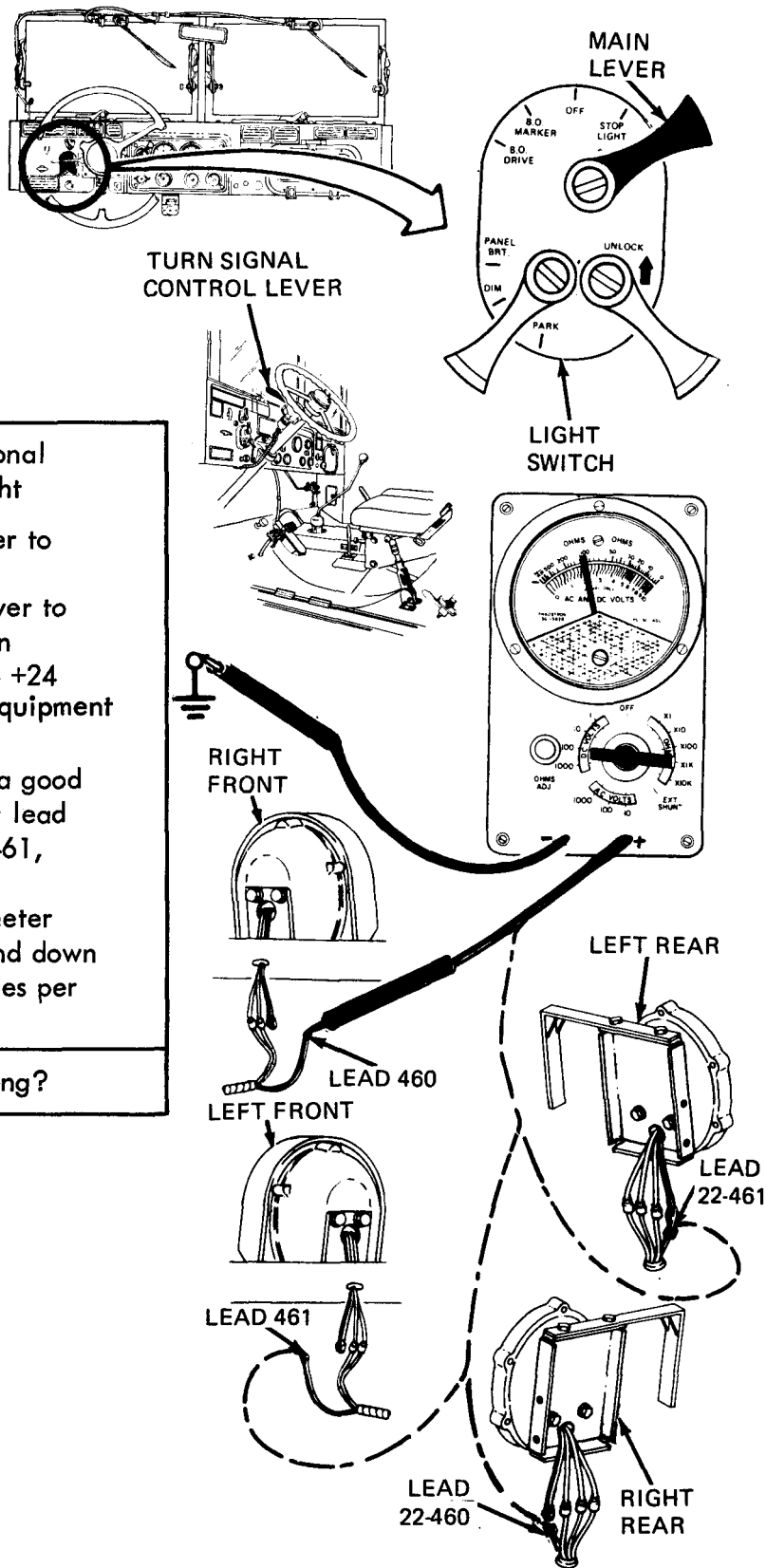

TA 114405

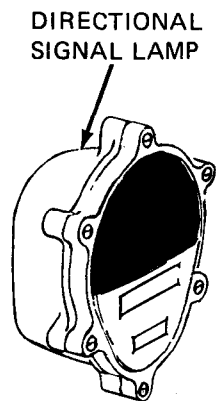
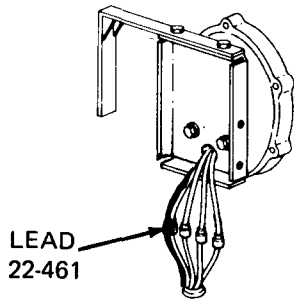
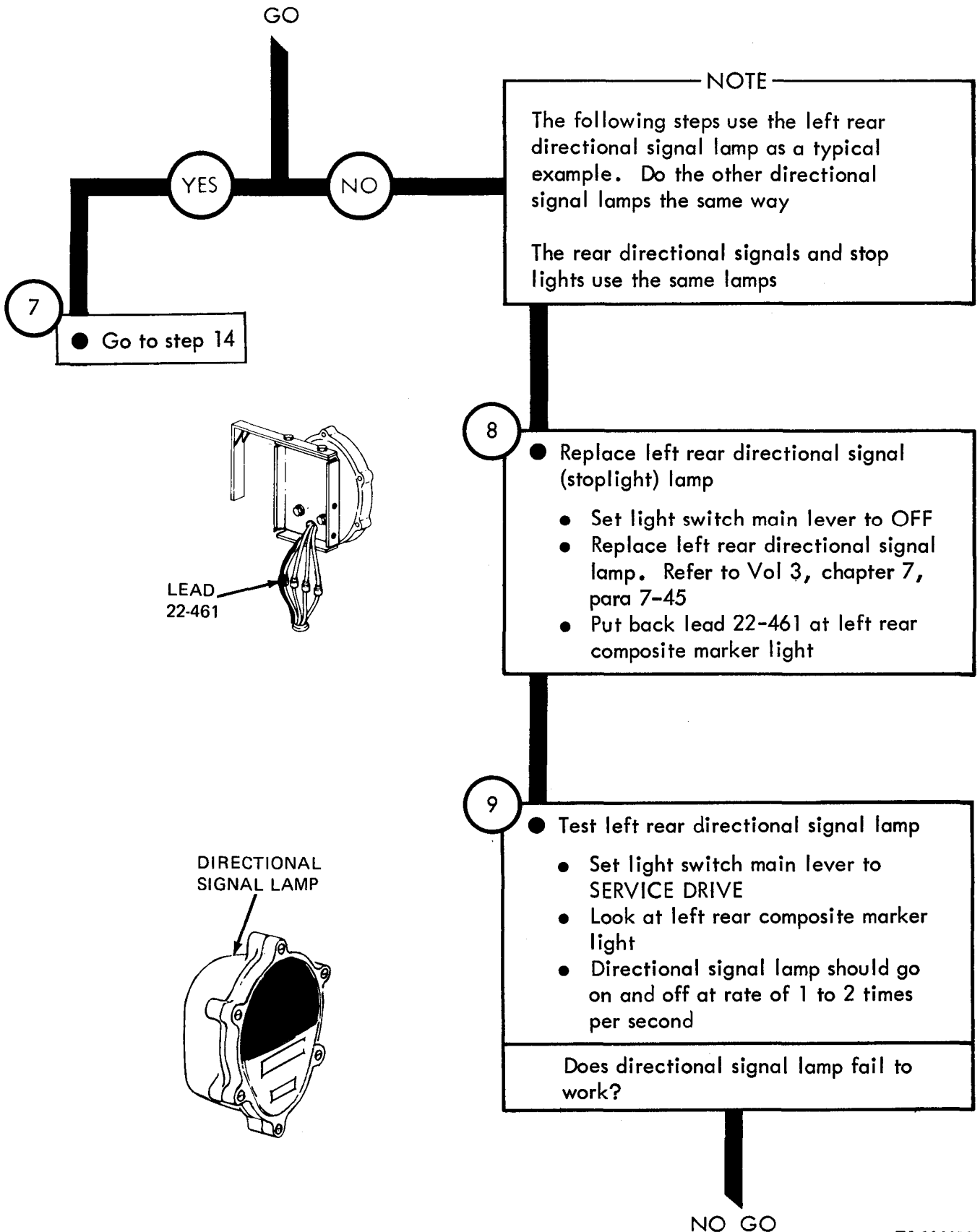
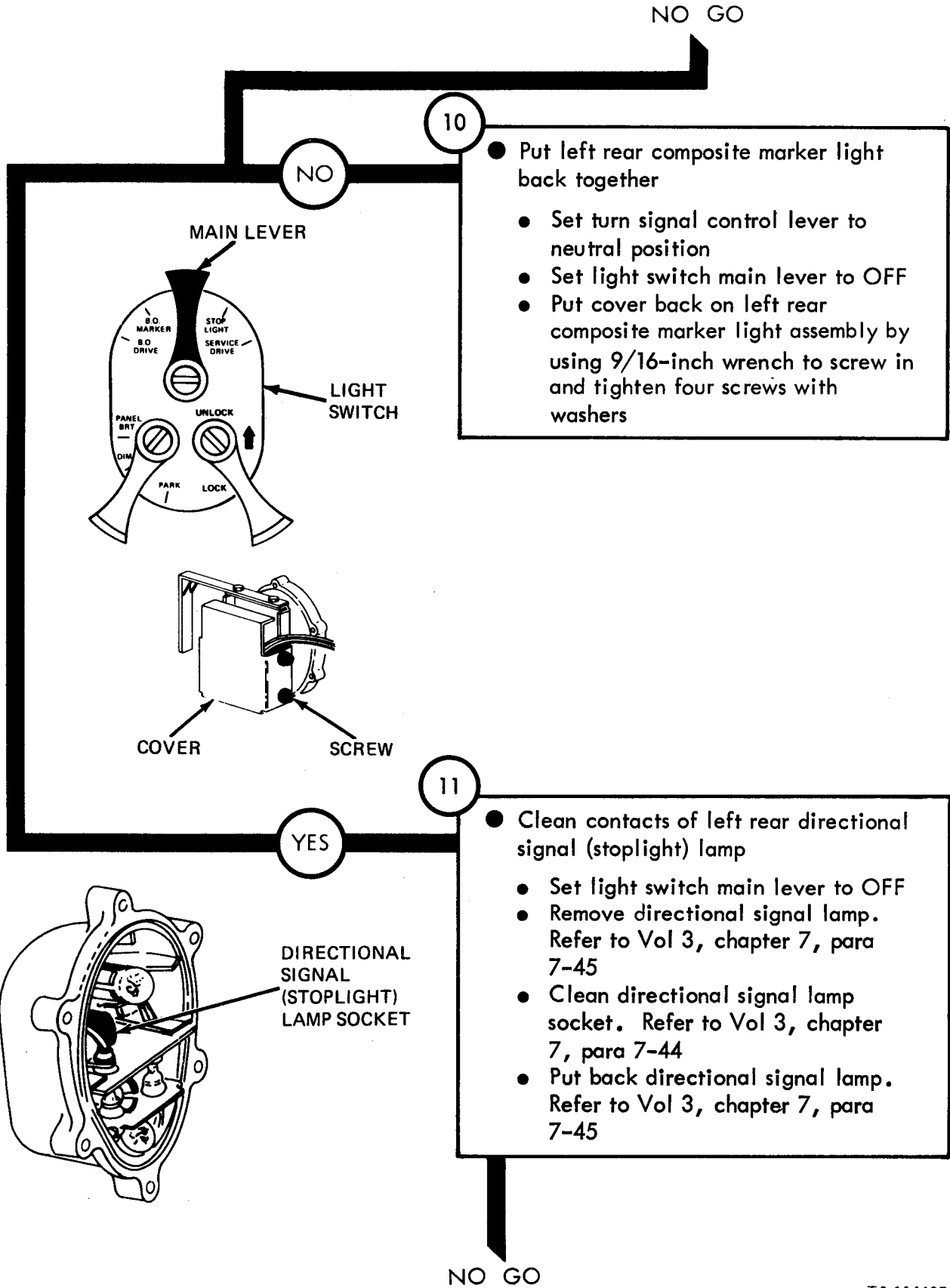
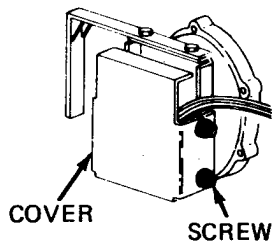
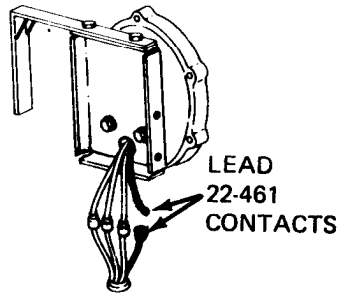

Figure 25-23 (Sheet 5 of 16)



TA 114407

NO GO



12

- Clean left rear directional signal (stoplight) lamp connector contacts
 - Take off lead 22-461
 - Clean lead 22-461 contacts. Refer to Vol 3, chapter 7, para 7-44
 - Push lead 22-461 into connector
 - Put cover back on rear composite marker light assembly by using 9/16-inch wrench to screw in and tighten four screws with washers

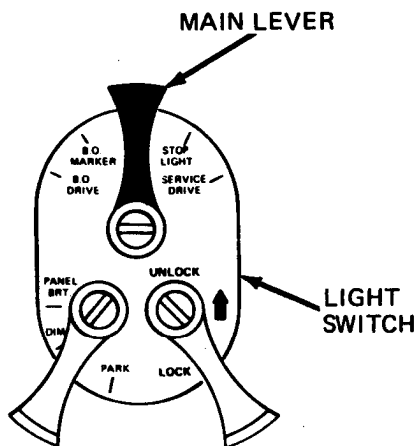

13

- Troubleshooting completed
 - Set turn signal control lever to neutral position

From step 7

LAMP CIRCUIT:	PLUG CONTACT:
RIGHT FRONT	A
LEFT FRONT	B
RIGHT REAR	E
LEFT REAR	C

14

- See if directional signal lamp circuit is shorted to ground
 - Set light switch main lever to OFF
 - Unscrew and take off turn signal control harness plug from turn signal control assembly
 - Set multimeter to check for short circuit. Refer to test equipment procedures index
 - Put multimeter - lead on a good ground. Put multimeter + lead on contact of turn signal control harness plug connector for circuit being tested
 - Read multimeter. A short circuit should not be indicated

Is signal lamp circuit OK?

GO

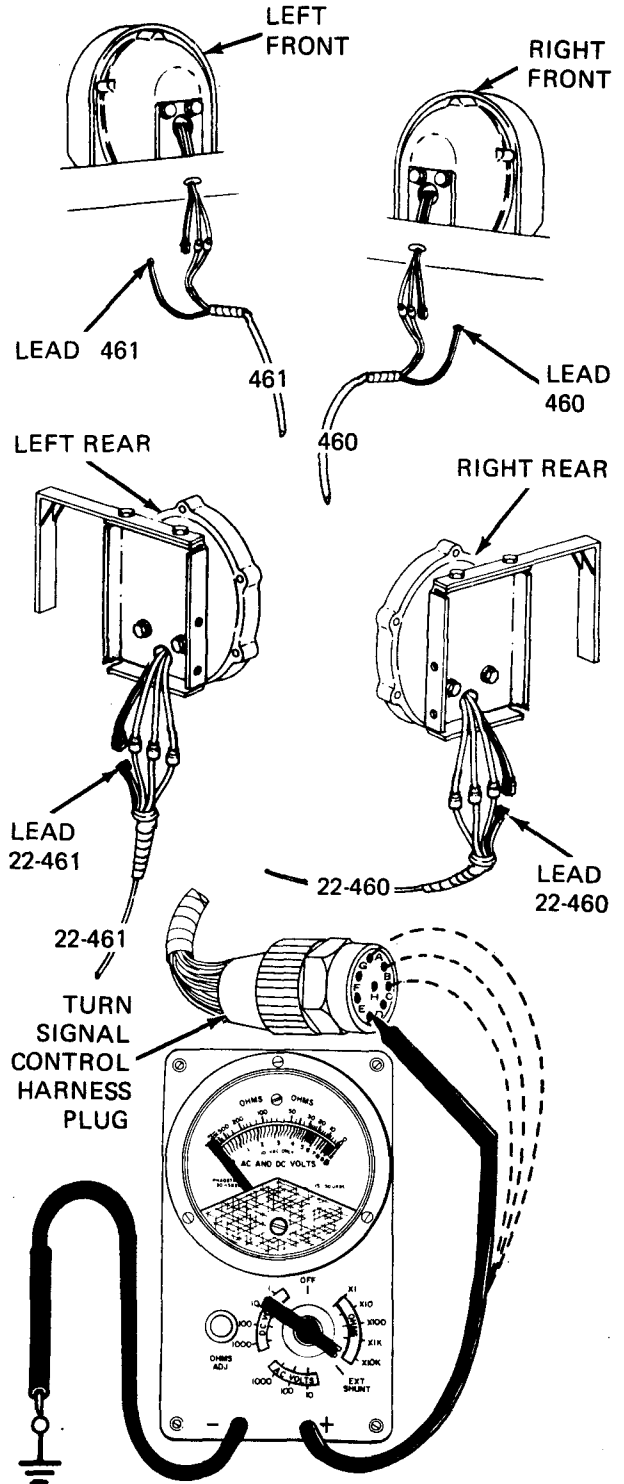

TA 114409

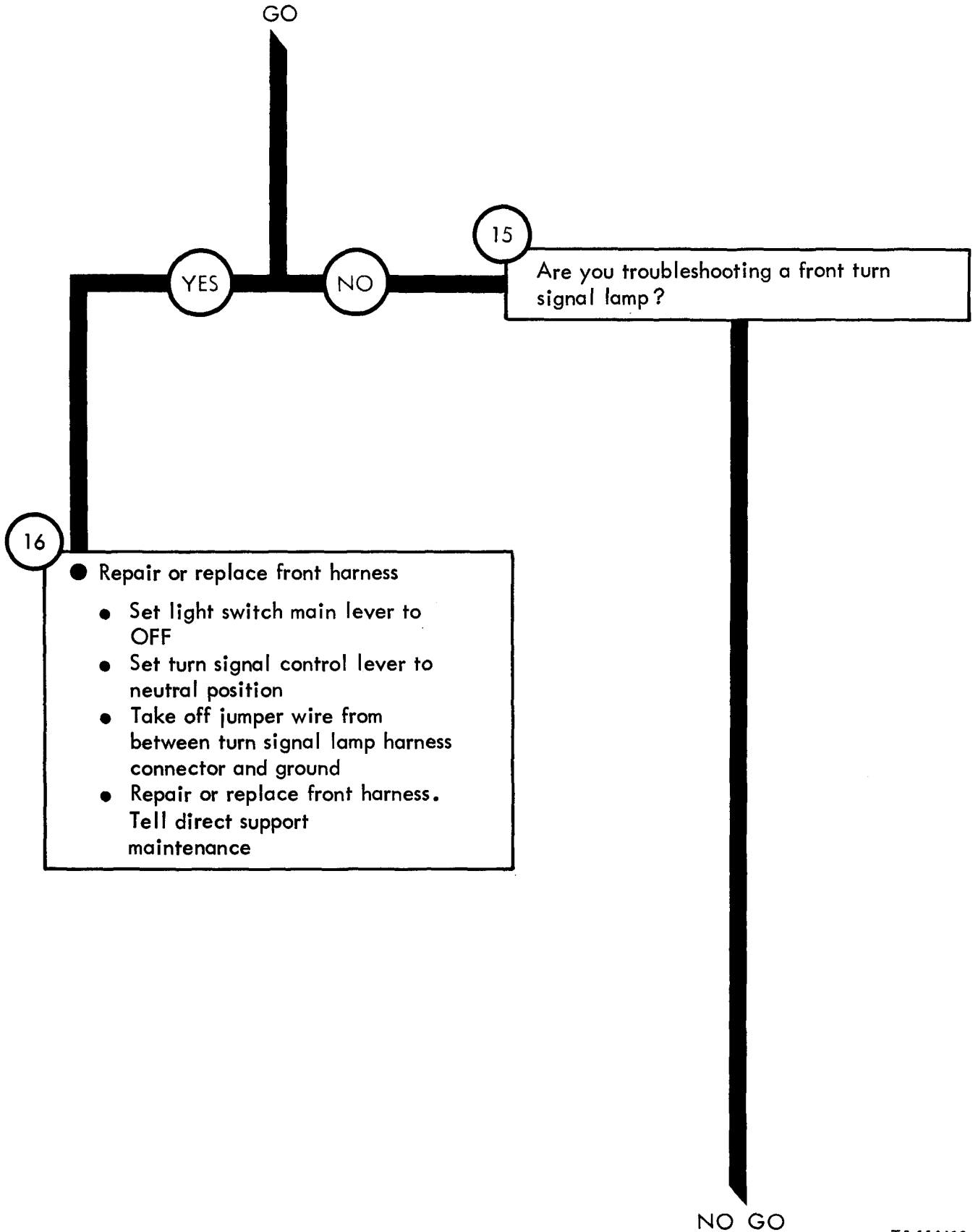
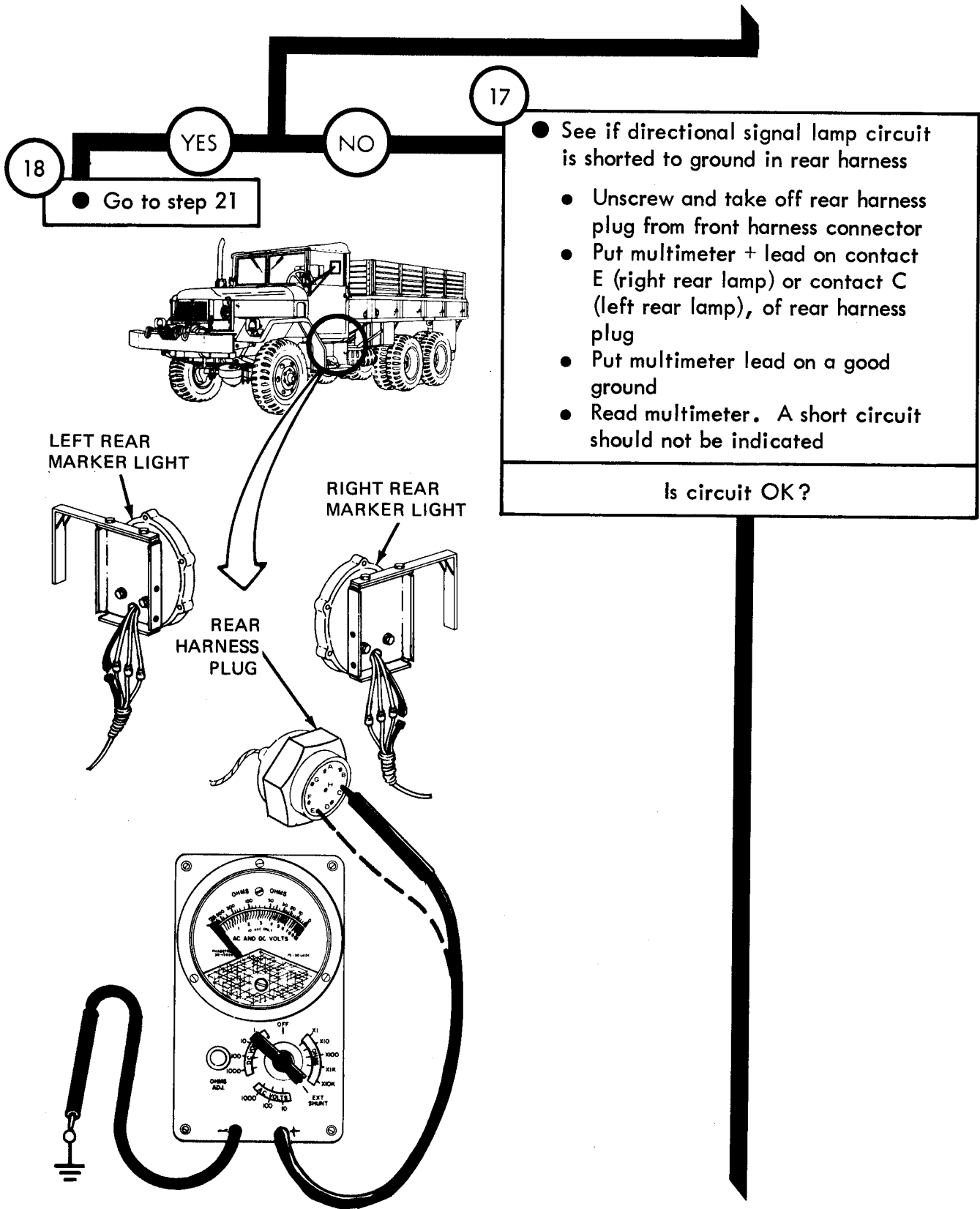

Figure 25-23 (Sheet 9 of 16)

NO GO



- See if directional signal lamp circuit is shorted to ground in rear harness
- Unscrew and take off rear harness plug from front harness connector
- Put multimeter + lead on contact E (right rear lamp) or contact C (left rear lamp), of rear harness plug
- Put multimeter lead on a good ground
- Read multimeter. A short circuit should not be indicated

Is circuit OK?

NO GO

TA 114411

NO GO

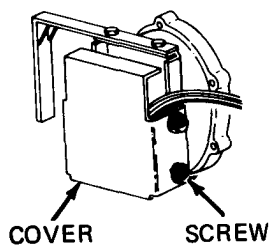
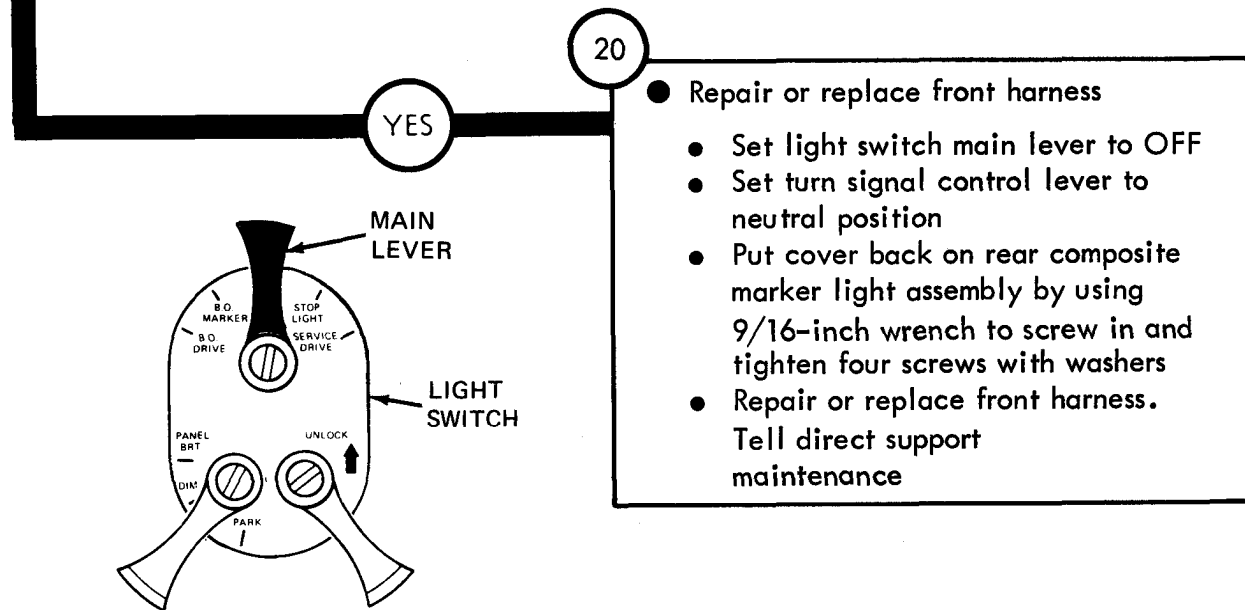
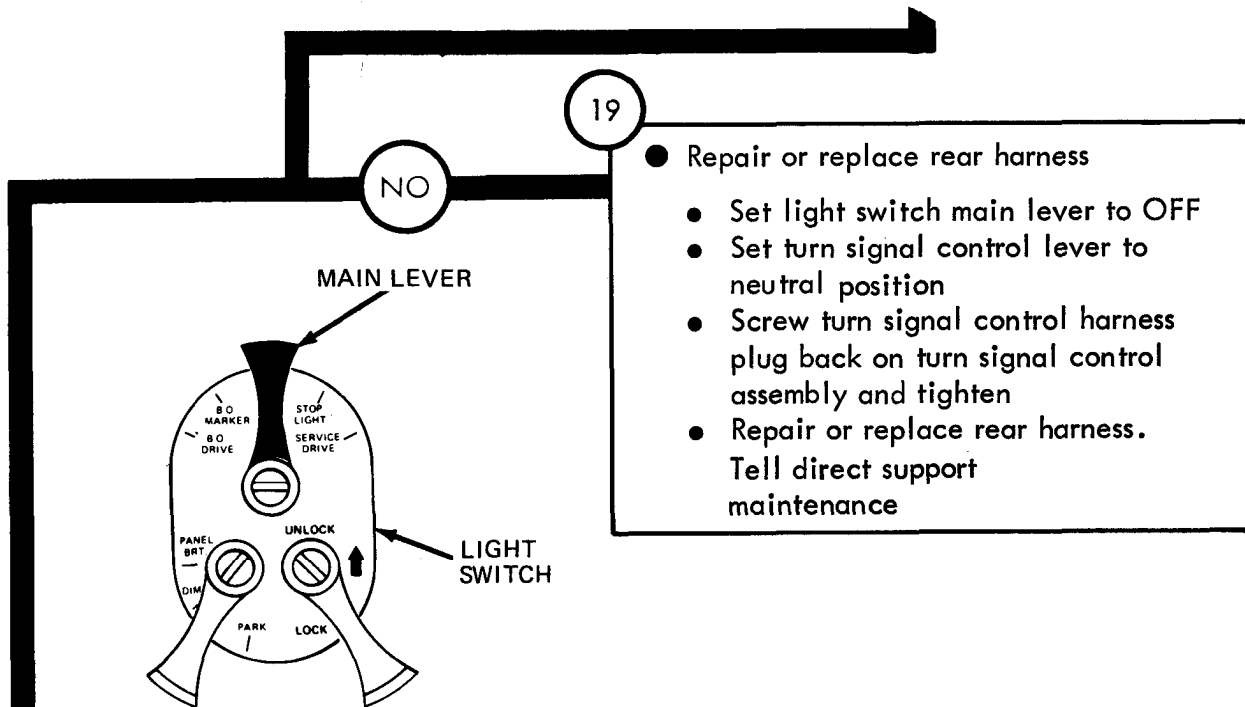

TA 114412

Figure 25-23 (Sheet 11 of 16)

From step 18

LAMP CIRCUIT:	PLUG CONTACT:
RIGHT FRONT	A
LEFT FRONT	B
RIGHT REAR	E
LEFT REAR	C

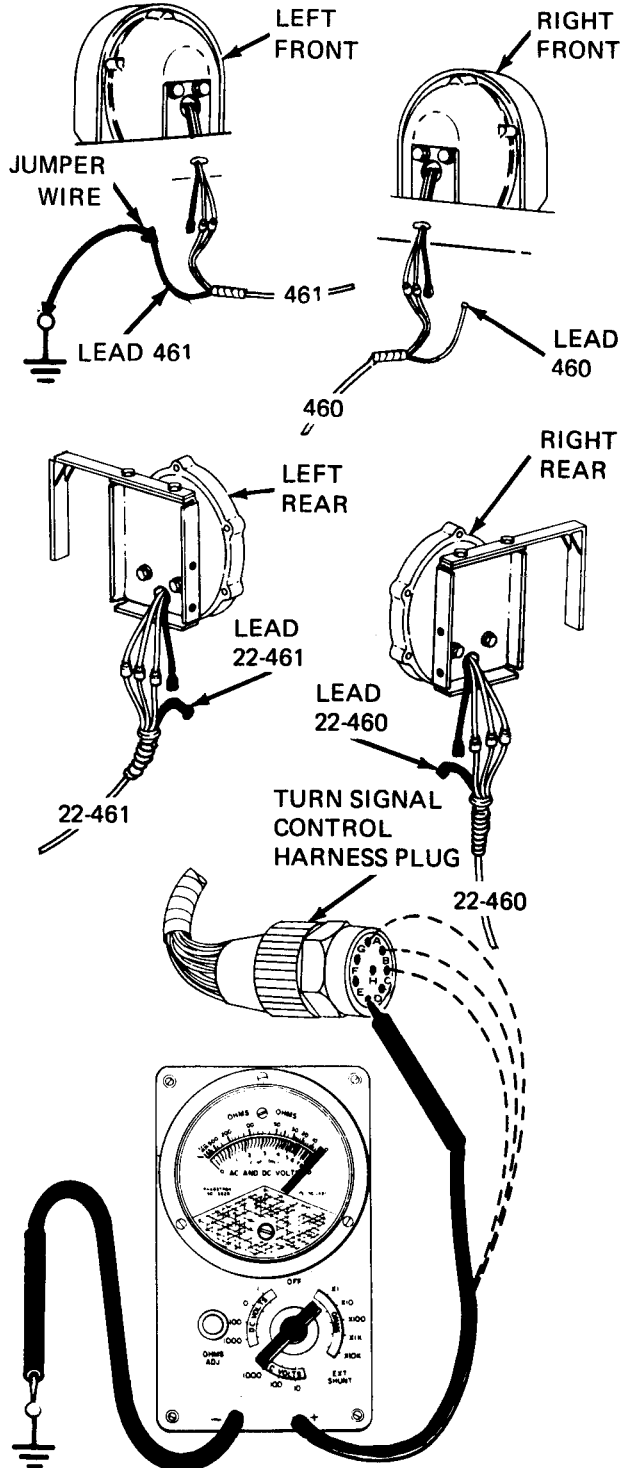

21

- Check for continuity in directional signal lamp circuit
 - Put jumper wire between turn signal lamp harness connector and a good ground
 - Set multimeter to check continuity. Refer to test equipment procedure index
 - Put multimeter + lead on correct lead contact of turn signal control harness plug. See table in picture
 - Put multimeter - lead on a good ground
 - Read multimeter. Pointer should measure zero ohms

Does multimeter measure more than zero ohms?

GO

TA 114413

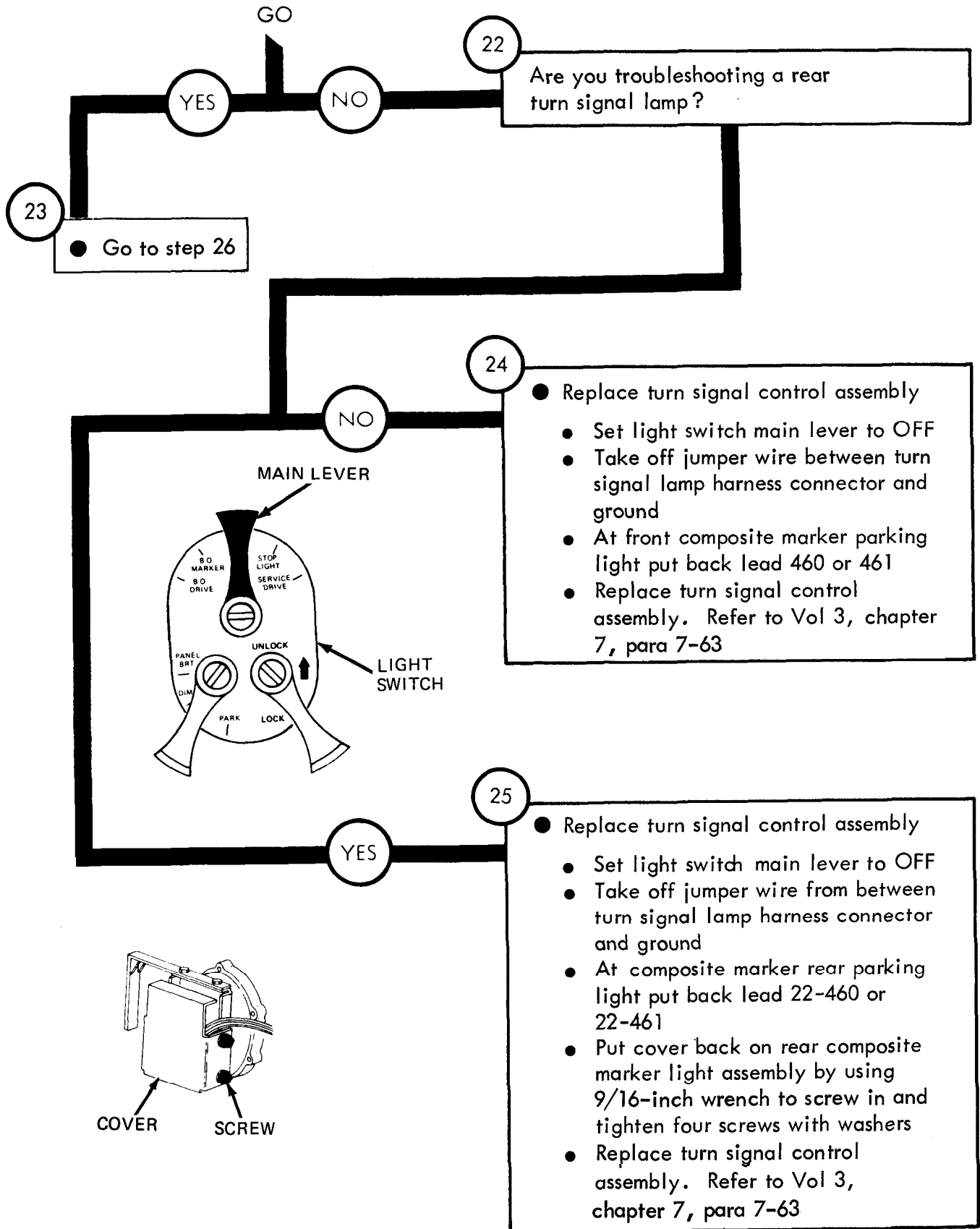

TA 114414

Figure 25-23 (Sheet 13 of 16)

From step 23

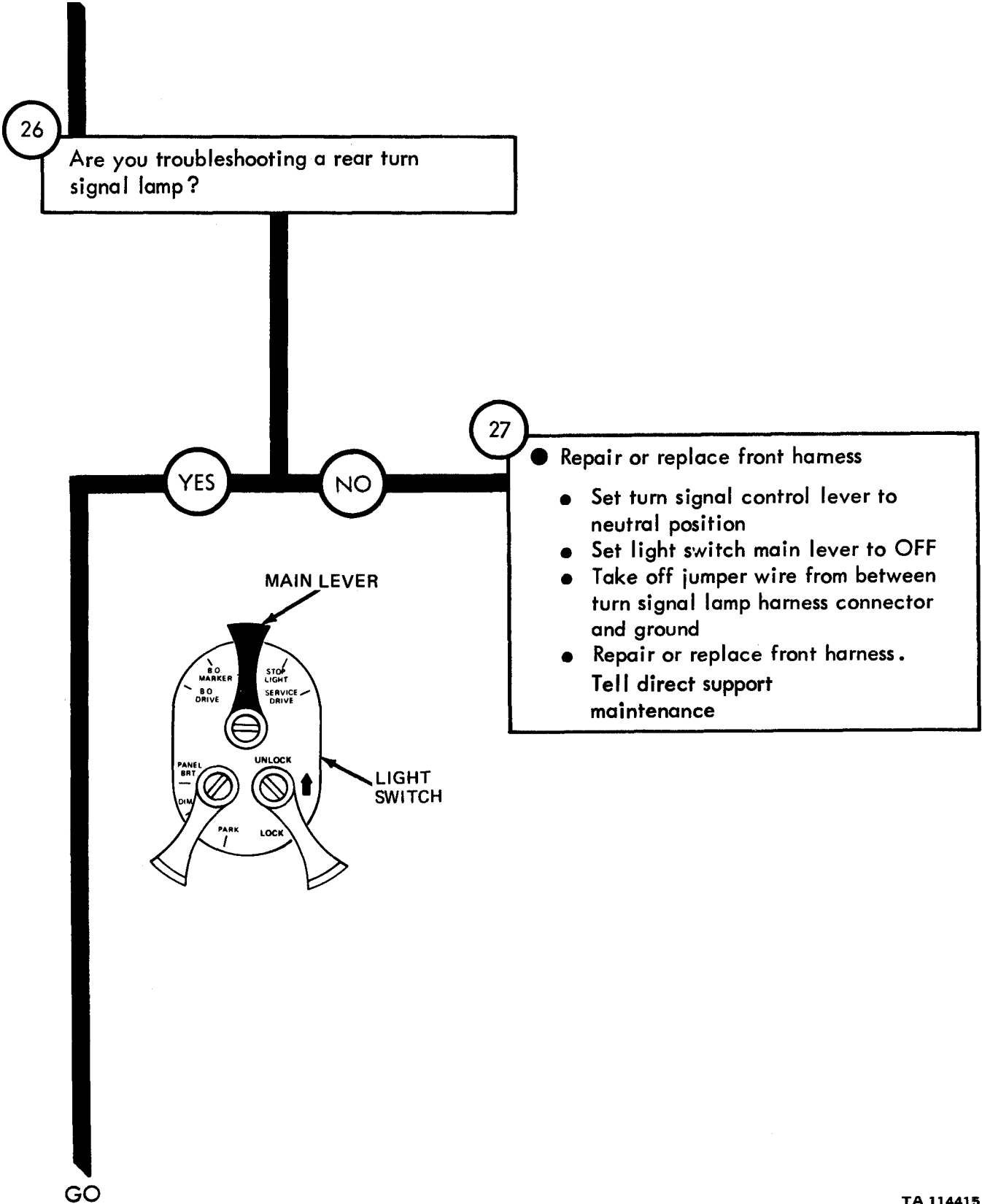

TA 114415

GO

28

- Check for continuity in directional signal lamp rear harness circuit
 - Unscrew and take off rear harness plug from front harness receptacle
 - Put a jumper wire between turn signal lamp harness connector and a good ground
 - Put multimeter + lead on contact E (right rear lamp), or contact C (left rear lamp), of rear harness plug
 - With multimeter still set to measure continuity put - lead on a good ground
 - Read multimeter. Pointer should measure zero ohms

Does multimeter measure zero ohms?

GO

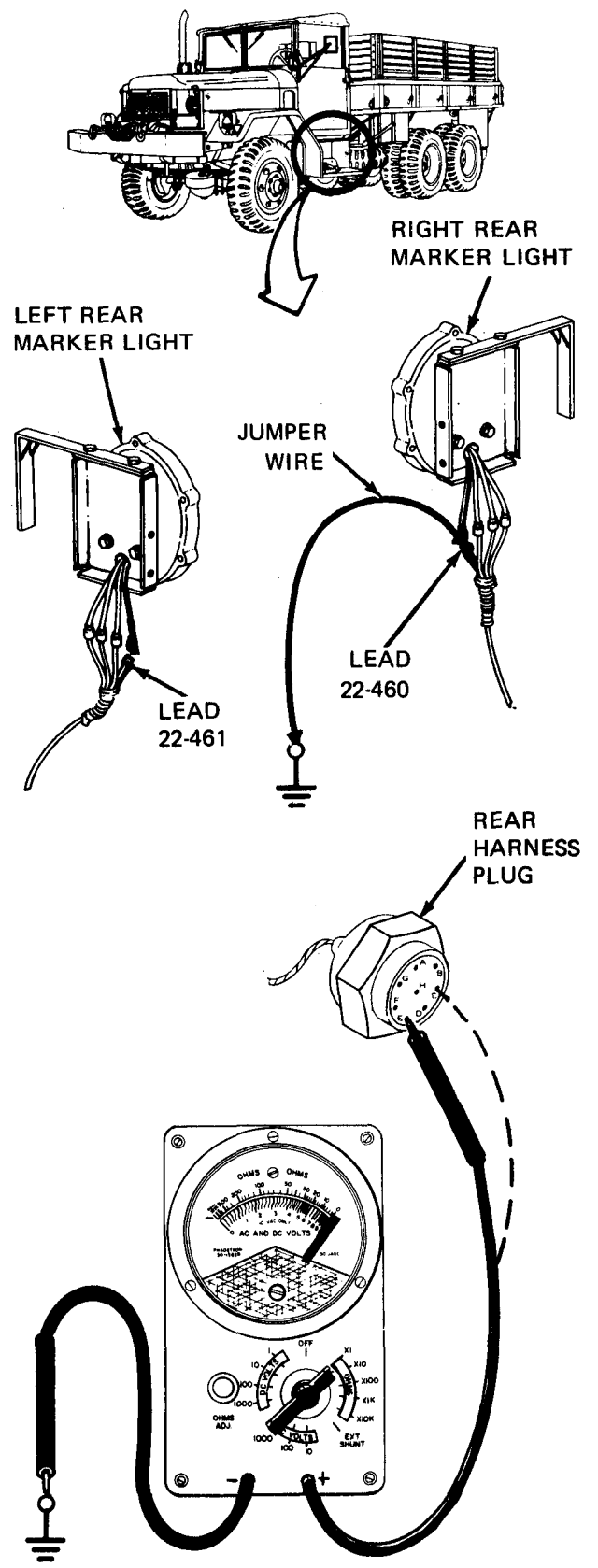

TA 114416

Figure 25-23 (Sheet 15 of 16)

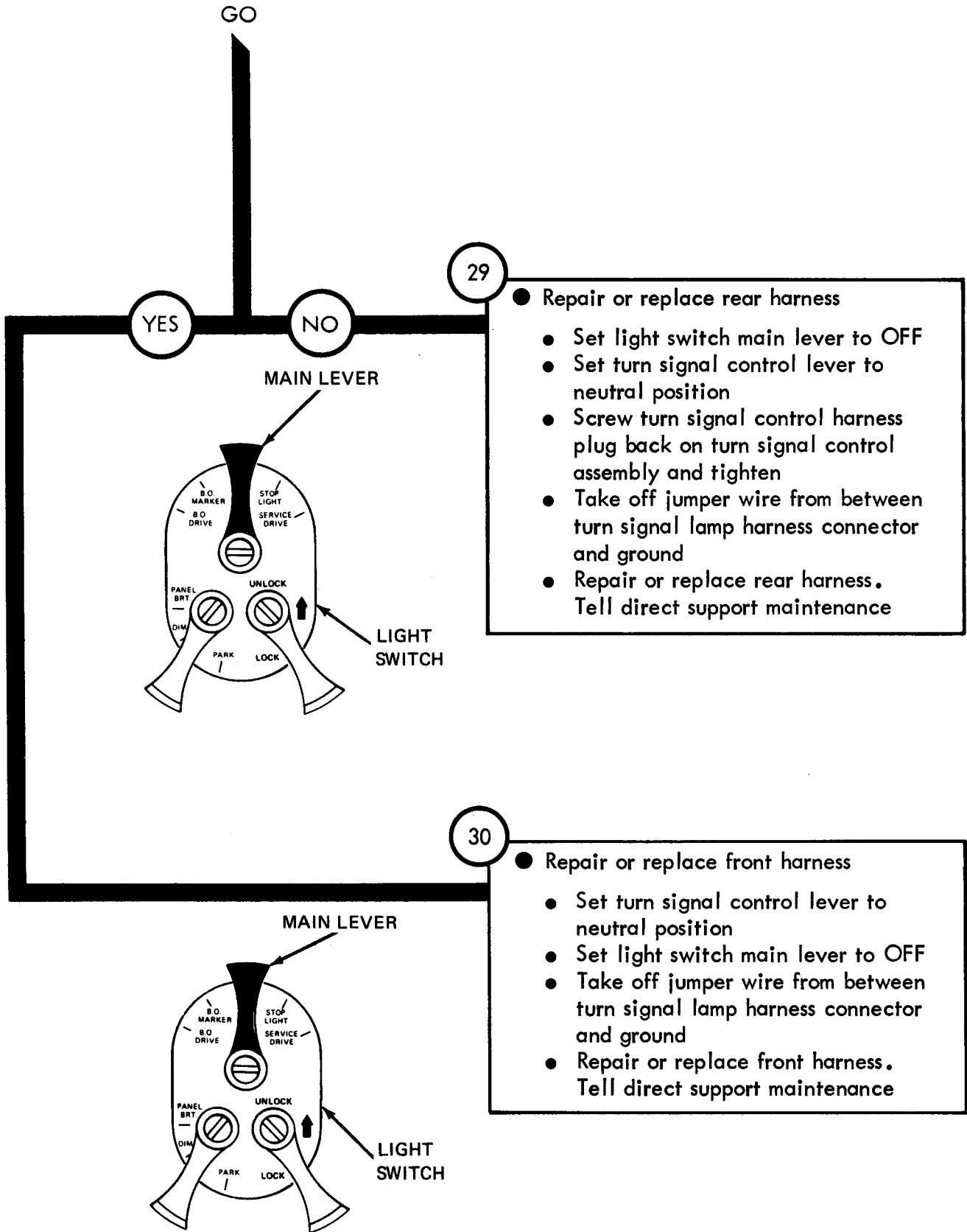

Symptom

24

NO CONTROL ASSEMBLY DIRECTIONAL SIGNAL LIGHTS LIGHT, OTHER TRUCK LIGHTS LIGHT

NOTE

When checking voltage, +24 volts DC means a range of +23 to +26 volts DC

1

- Park truck
- Refer to TM 9-2320-209-10

GO

TA 114418

Figure 25-24 (Sheet 1 of 6)

GO

2

- Check that +24 volts DC is getting to turn signal control
- Unscrew and take off turn signal control harness plug from turn signal control assembly
- Set light switch main lever to STOPLIGHT

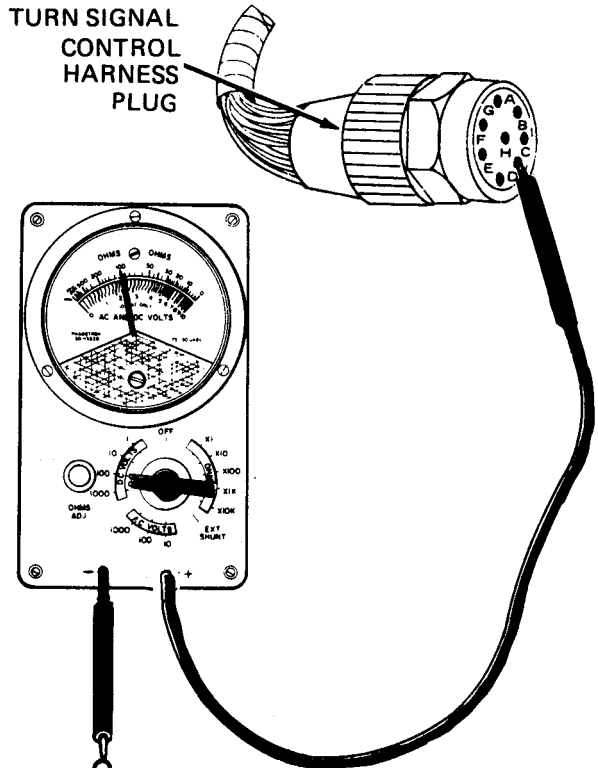
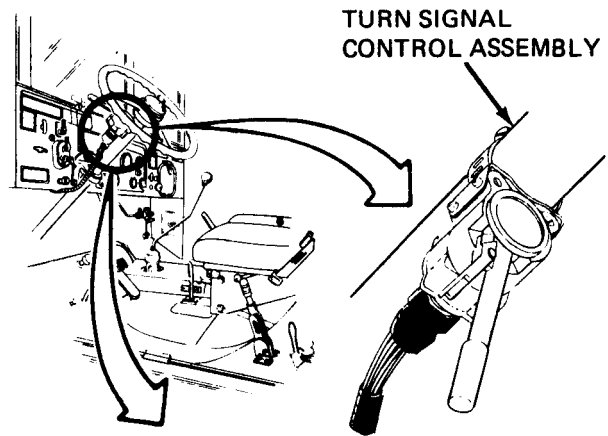

- Set multimeter to measure +24 volts DC. Refer to test equipment procedures index
- Put multimeter + lead on contact G of harness plug
- Put multimeter - lead on a good ground
- Read multimeter. Multimeter should measure +24 volts DC

Does multimeter measure +24 volts DC?

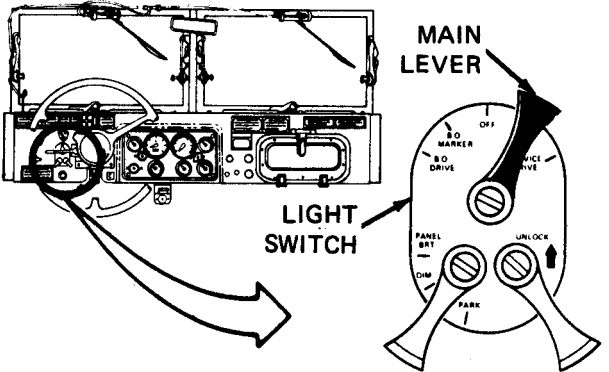

GO

TA 114419

Figure 25-24 (Sheet 2 of 6)

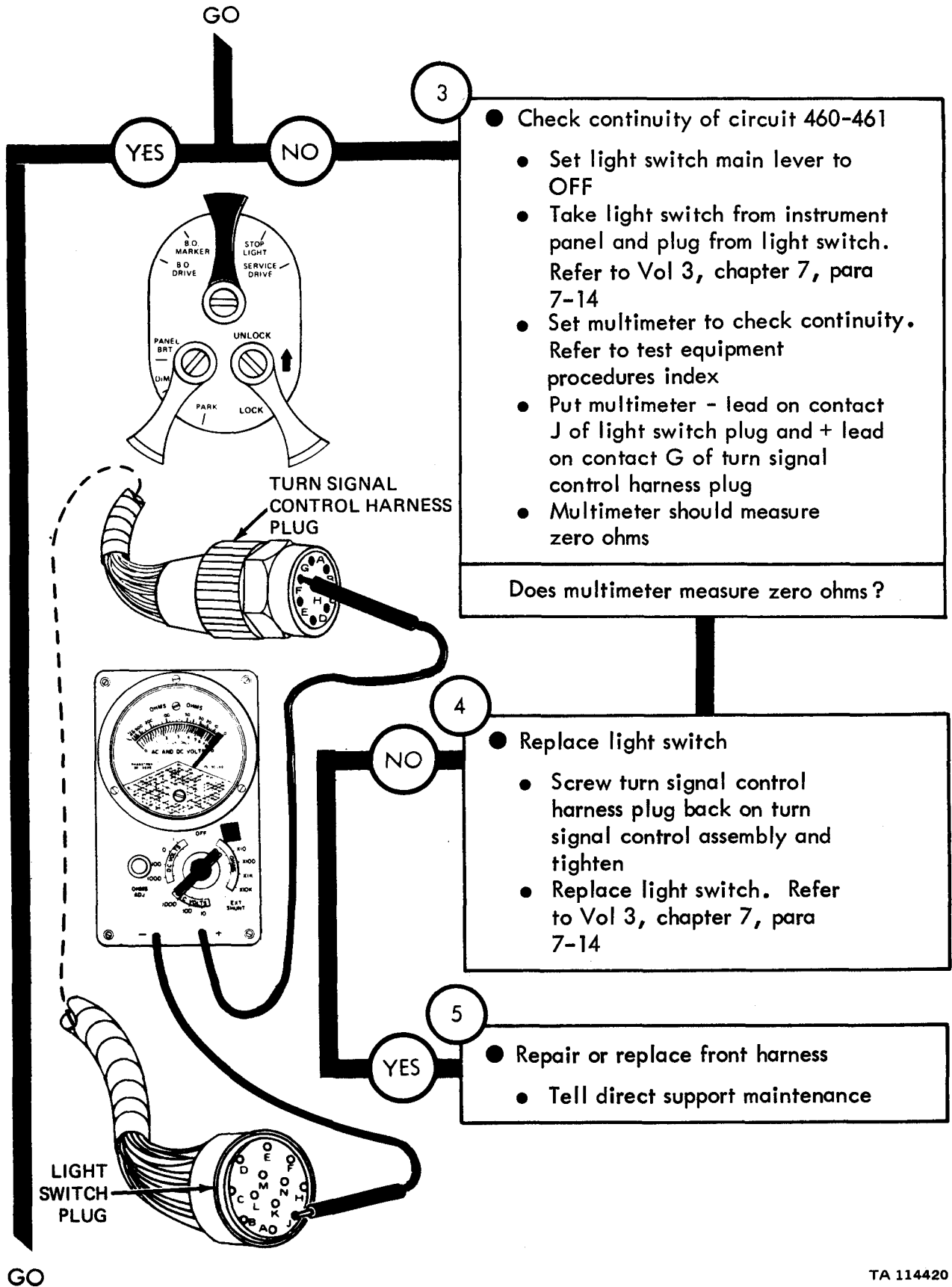

Figure 25-24 (Sheet 3 of 6)

GO

6

- Check harness between turn signal control lever and flasher for continuity
 - Unscrew and take off flasher harness plug from turn signal flasher
 - Set multimeter to check continuity. Refer to test equipment index
 - Put multimeter + lead on contact B of flasher harness plug and - lead on contact F of turn signal harness plug. Read multimeter
 - Put multimeter + lead on contact A of flasher harness plug and - lead on contact H of turn signal harness plug. Read multimeter
 - Put multimeter + lead on contact C of flasher harness plug and - lead on a good ground. Read multimeter. Multimeter should measure zero ohms for each test

Did multimeter measure zero ohms for each test?

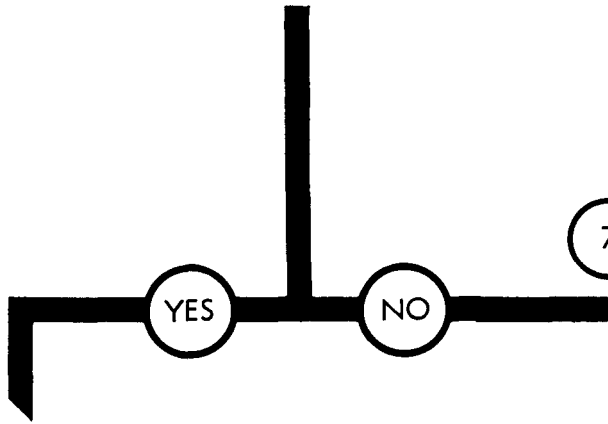
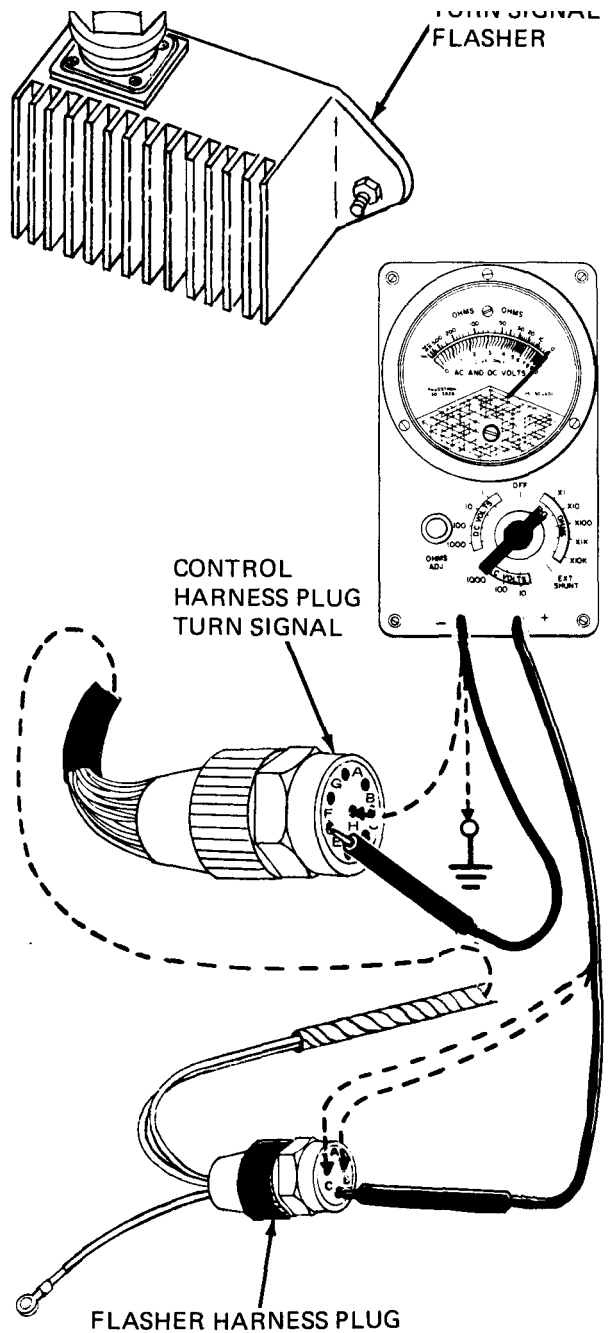

- Repair or replace front harness
- Tell direct support maintenance

GO

TA 114421

Figure 25-24 (Sheet 4 of 6)

GO

8

- Replace turn signal flasher
 - Screw turn signal control harness plug back on turn signal control assembly and tighten
 - Replace turn signal flasher. Refer to Vol 3, chapter 7, para 7-63

9

- See if control assembly directional signal lamps work
 - Set light switch main switch to SERVICE DRIVE
 - Set turn signal control lever to emergency flasher position
 - Look at two front and two rear turn signal lamps, and green turn signal control assembly lamp. All lamps should be flashing together one to two times per second

Checkout OK?

GO

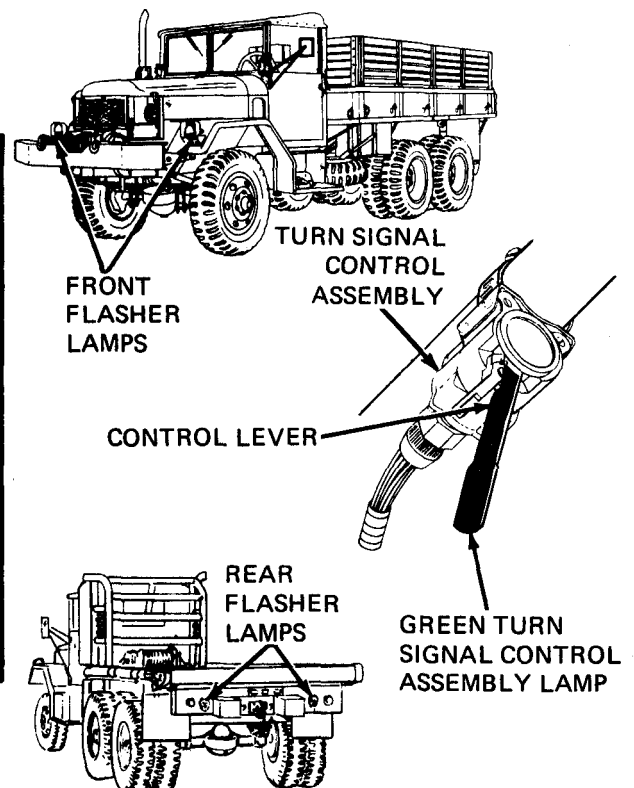

TA 114422

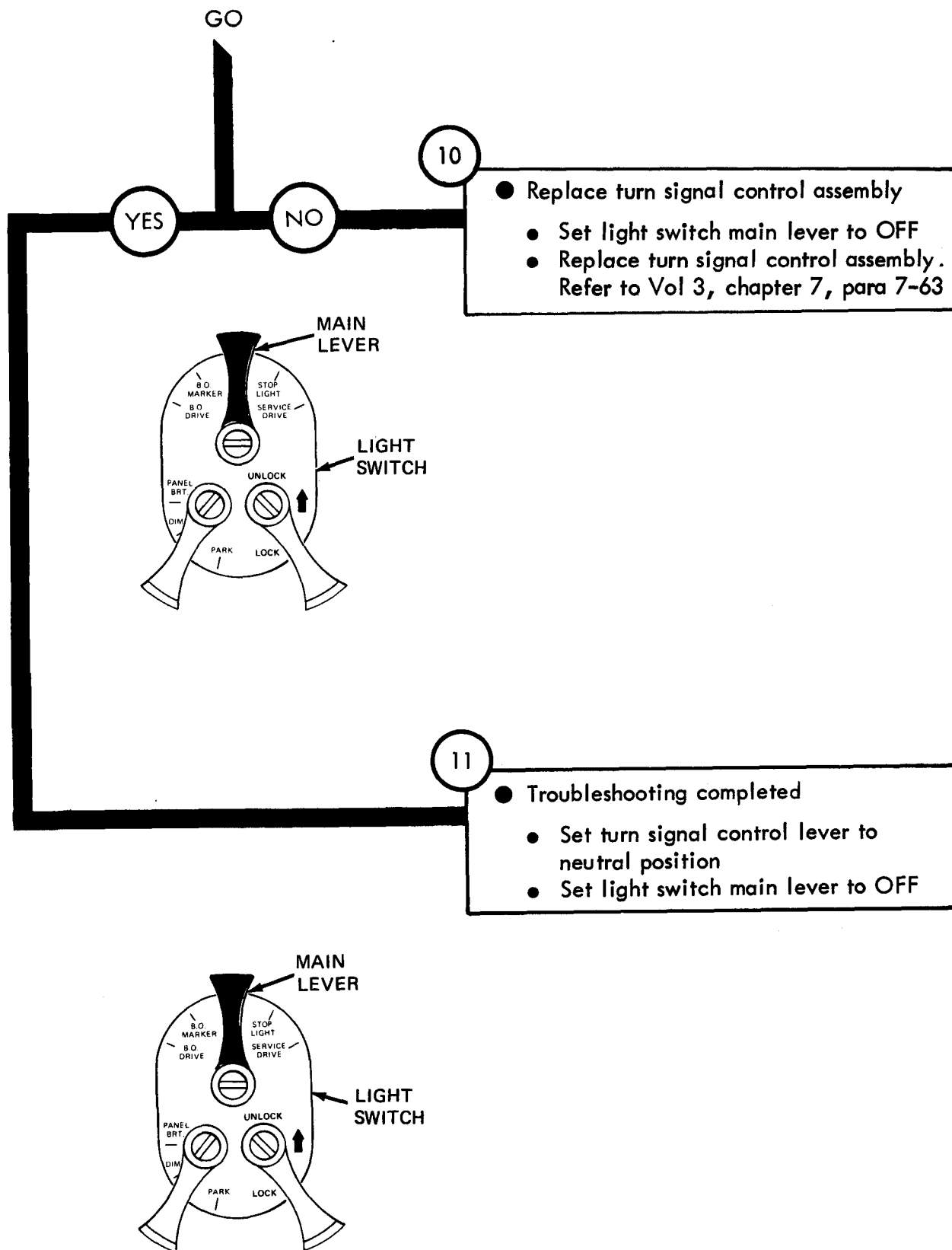

TA 114423

Figure 25-24 (Sheet 6 of 6)

Symptom

25

WHEN EMERGENCY FLASHER OR TURN SIGNAL LIGHTS ARE SELECTED, LIGHTS DO NOT FLASH OR FLASH AT SLOW OR UNEVEN RATE

NOTE

When checking voltage + 24 DC means a range of + 23 to + 26 volts DC

1

- Park truck
- Refer to TM 9-2320-209-10

GO

GO

2

- Check turn signal flasher unit for +24 volts DC
 - Open battery box door and pull out batteries. Refer to Vol 3, chapter 7, para 7-55
 - Unscrew and take off turn signal flasher harness plug from turn signal flasher
 - Put a jumper wire between contact C on flasher to a good ground
 - Put a second jumper wire from + terminal of battery to contact B of flasher

- Set multimeter to measure +24 volts DC. Refer to test equipment procedures index
- Put multimeter - lead on contact C of flasher
- Put multimeter + lead on contact C of flasher. Multimeter should read 0 to 24 volts DC at flasher rate, 1 to 2 times per second

OK?

GO

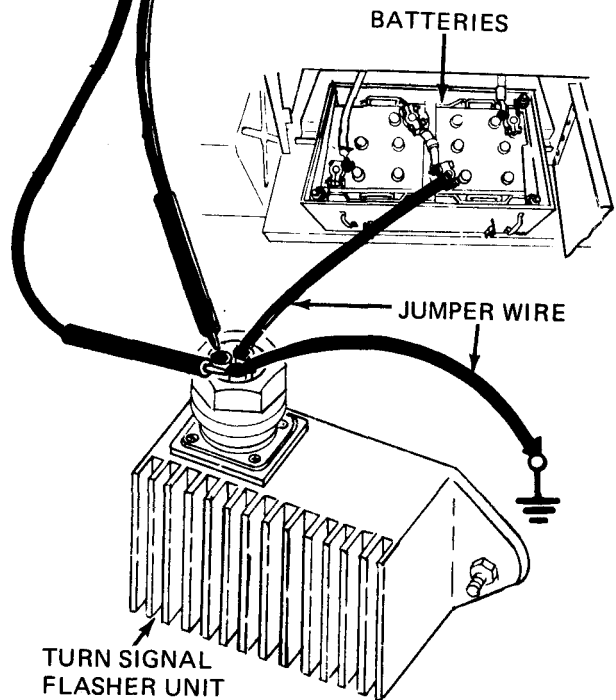
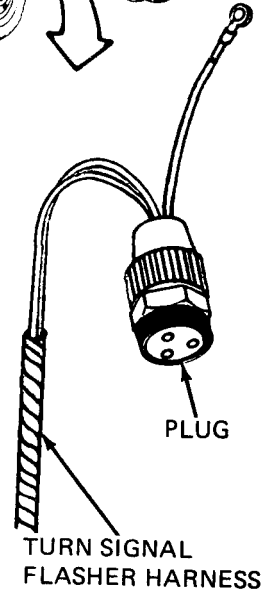
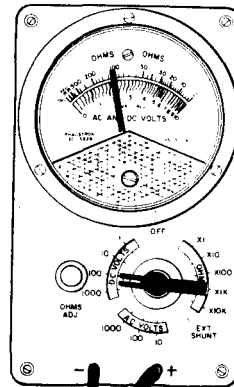
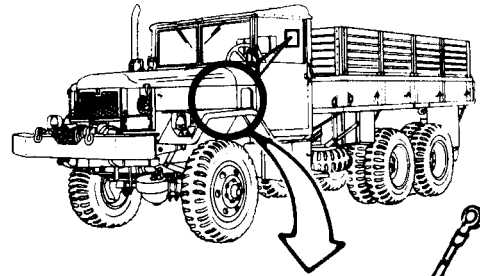

TA 114425

Figure 25-25 (Sheet 2 of 3)

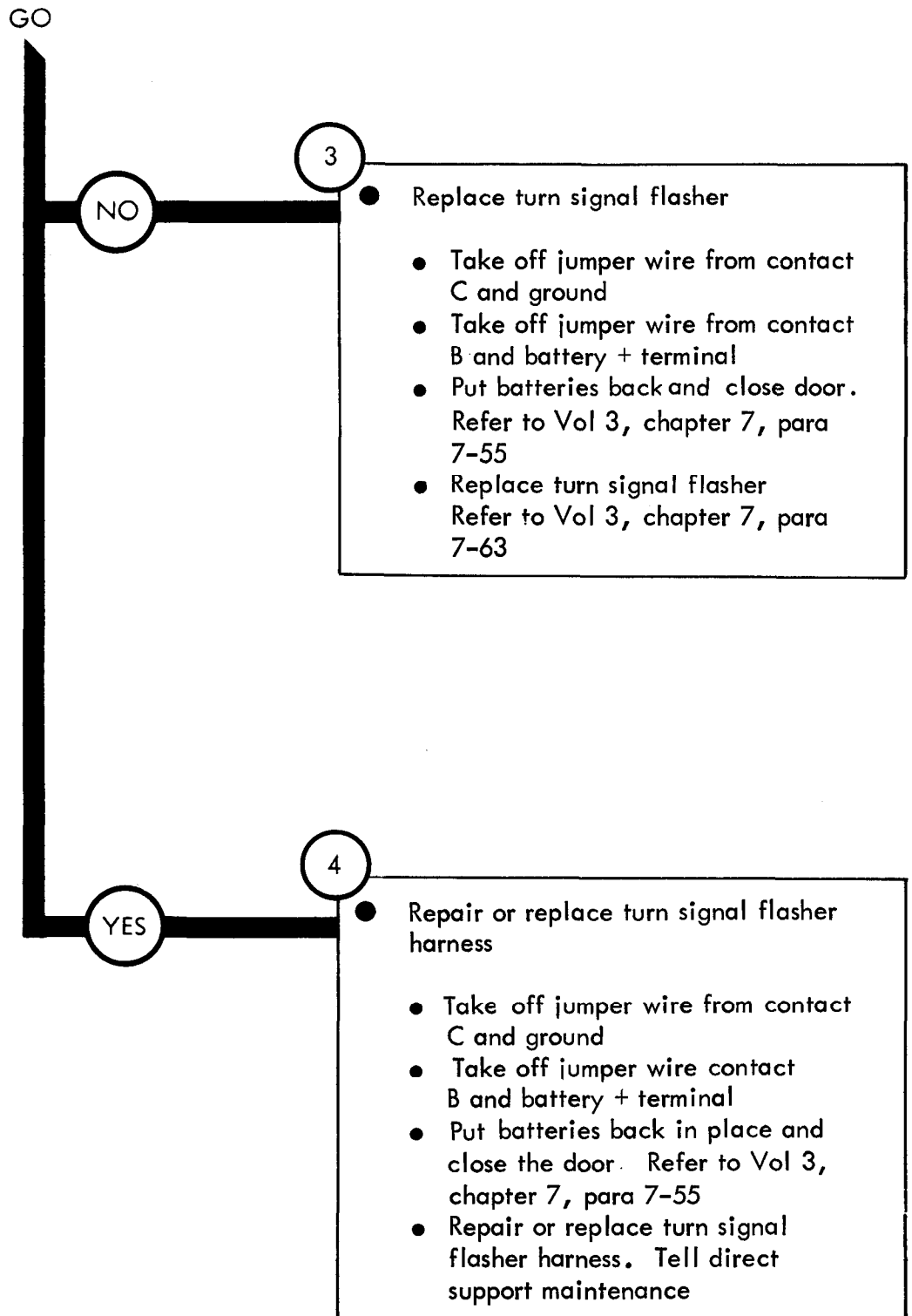

Figure 25-25 (Sheet 3 of 3)

Symptom

26 TURN SIGNALS DO NOT LIGHT IN ONE OR MORE POSITIONS OF CONTROL ASSEMBLY DIRECTIONAL SIGNAL LEVER, ALL OTHER TRUCK LIGHTS LIGHT

1

- Park truck
- Refer to TM 9-2320-209-10

2

- Take control assembly directional signal off steering column
- Take turn signal control assembly lamp out of turn signal lever. Refer to Vol 3, chapter 7, para 7-63
- Remove turn signal control assembly from steering column. Refer to Vol 3, chapter 7, para 7-63

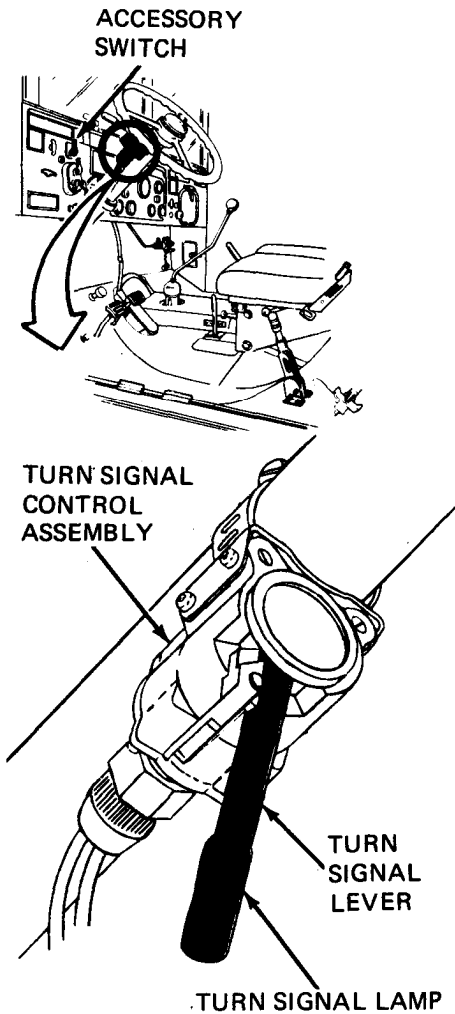

GO

1A 114427

Figure 25-26 (Sheet 1 of 6)

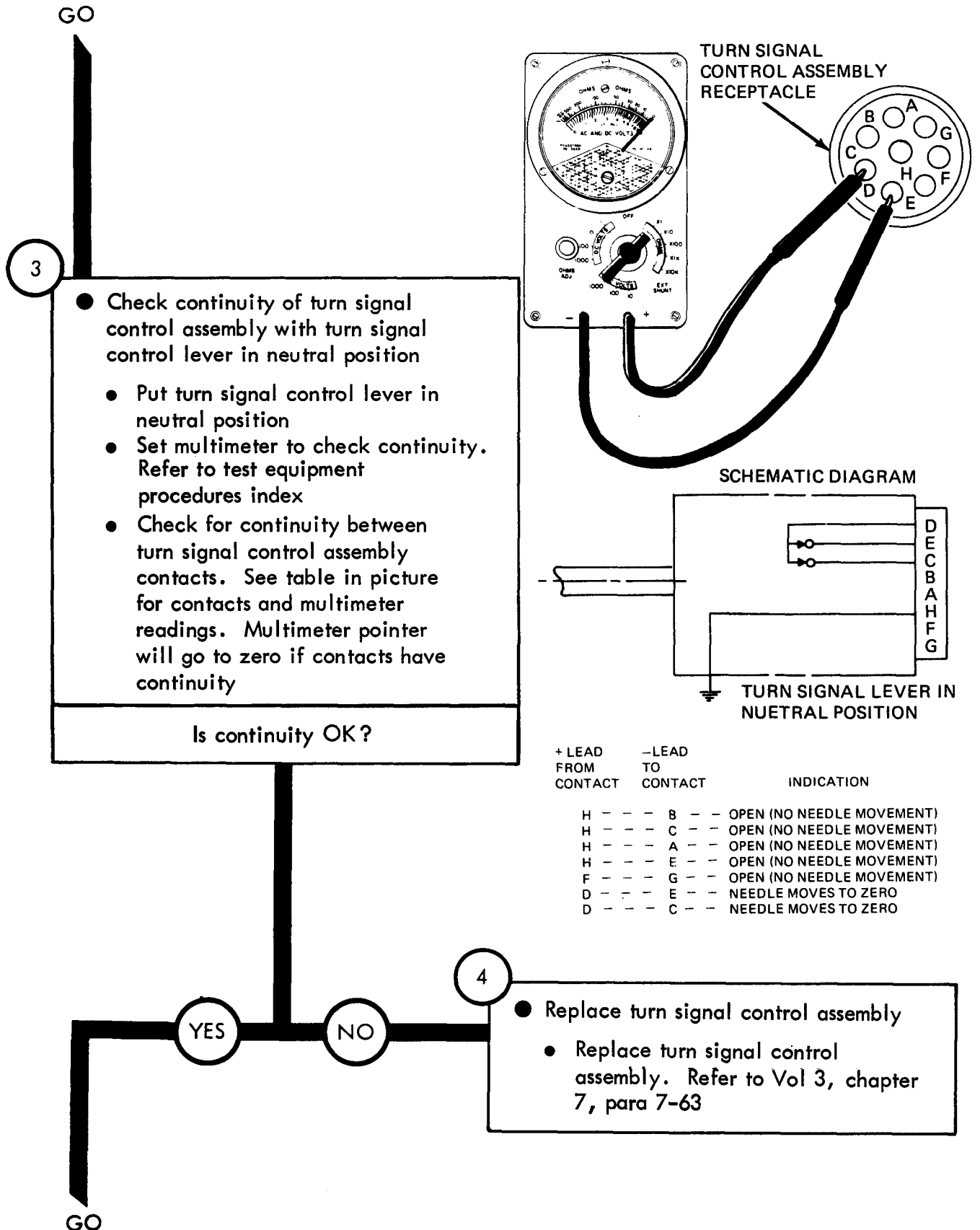

Figure 25-26 (Sheet 2 of 6)

GO

5

- Check continuity of turn signal control assembly with turn signal control lever in left turn position
- Set turn signal control lever to right turn position
- Using multimeter check for continuity between turn signal control assembly contacts. See table in picture for contacts and multimeter readings
- Multimeter pointer will go to zero if contacts have continuity

Is continuity OK?

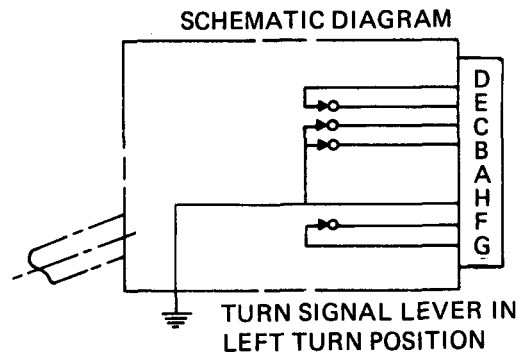
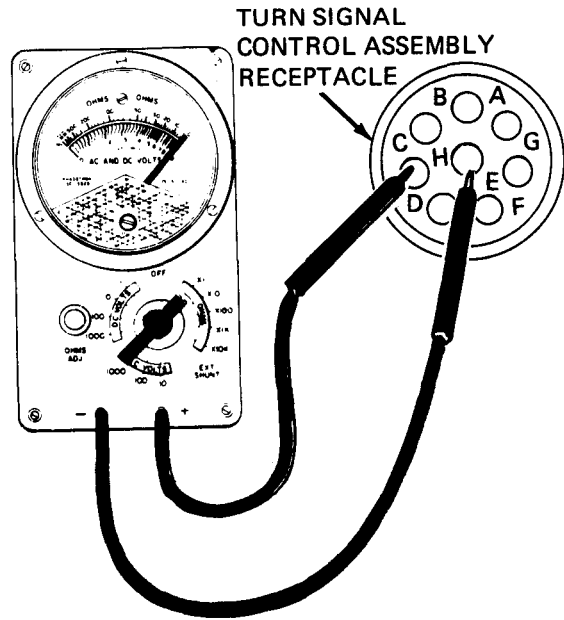

+ LEAD FROM CONTACT	- LEAD TO CONTACT	INDICATION
H	B	NEEDLE MOVES TO ZERO
H	C	NEEDLE MOVES TO ZERO
H	A	OPEN (NO NEEDLE MOVEMENT)
H	E	OPEN (NO NEEDLE MOVEMENT)
F	G	NEEDLE MOVES TO ZERO
D	E	NEEDLE MOVES TO ZERO
D	C	OPEN (NO NEEDLE MOVEMENT)

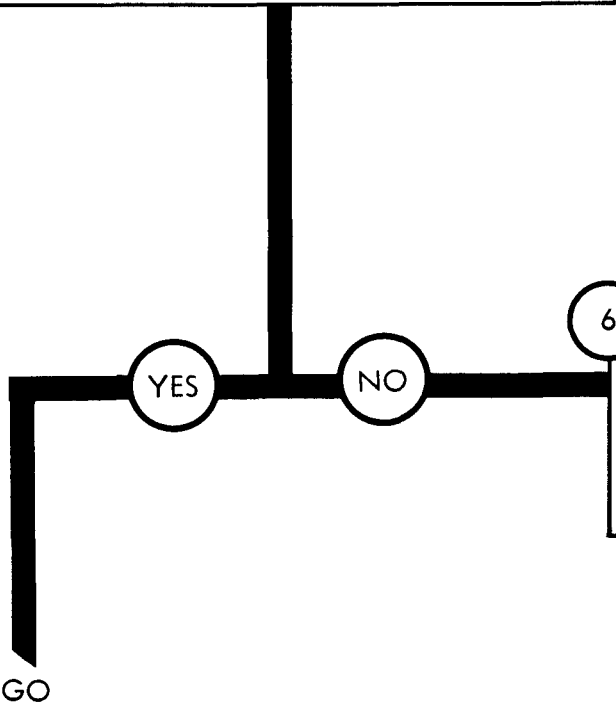

6

- Replace turn signal control assembly
- Replace turn signal control assembly. Refer to Vol 3, chapter 7, para 7-63

Figure 25-26 (Sheet 3 of 6)

GO

7

- Check continuity of turn signal control assembly with turn signal control lever in right turn position
 - Set turn signal control lever to left turn position
 - Using multimeter check for continuity between turn signal control assembly contacts. See table in picture for contacts and multimeter readings
 - Multimeter pointer will go to zero if contacts have continuity

Is continuity OK?

GO

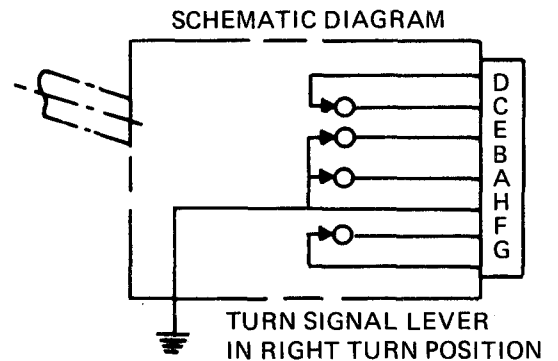
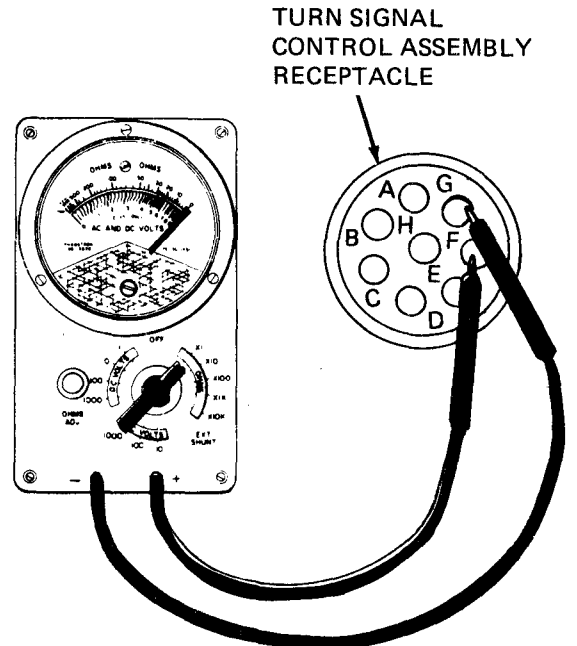

+ LEAD FROM CONTACT	-LEAD TO CONTACT	INDICATION
F	G	NEEDLE MOVES TO ZERO
H	A	NEEDLE MOVES TO ZERO
H	E	NEEDLE MOVES TO ZERO
H	B	OPEN (NO NEEDLE MOVEMENT)
H	C	OPEN (NO NEEDLE MOVEMENT)
D	C	NEEDLE MOVES TO ZERO
D	E	OPEN (NO NEEDLE MOVEMENT)

Figure 25-26 (Sheet 4 of 6)

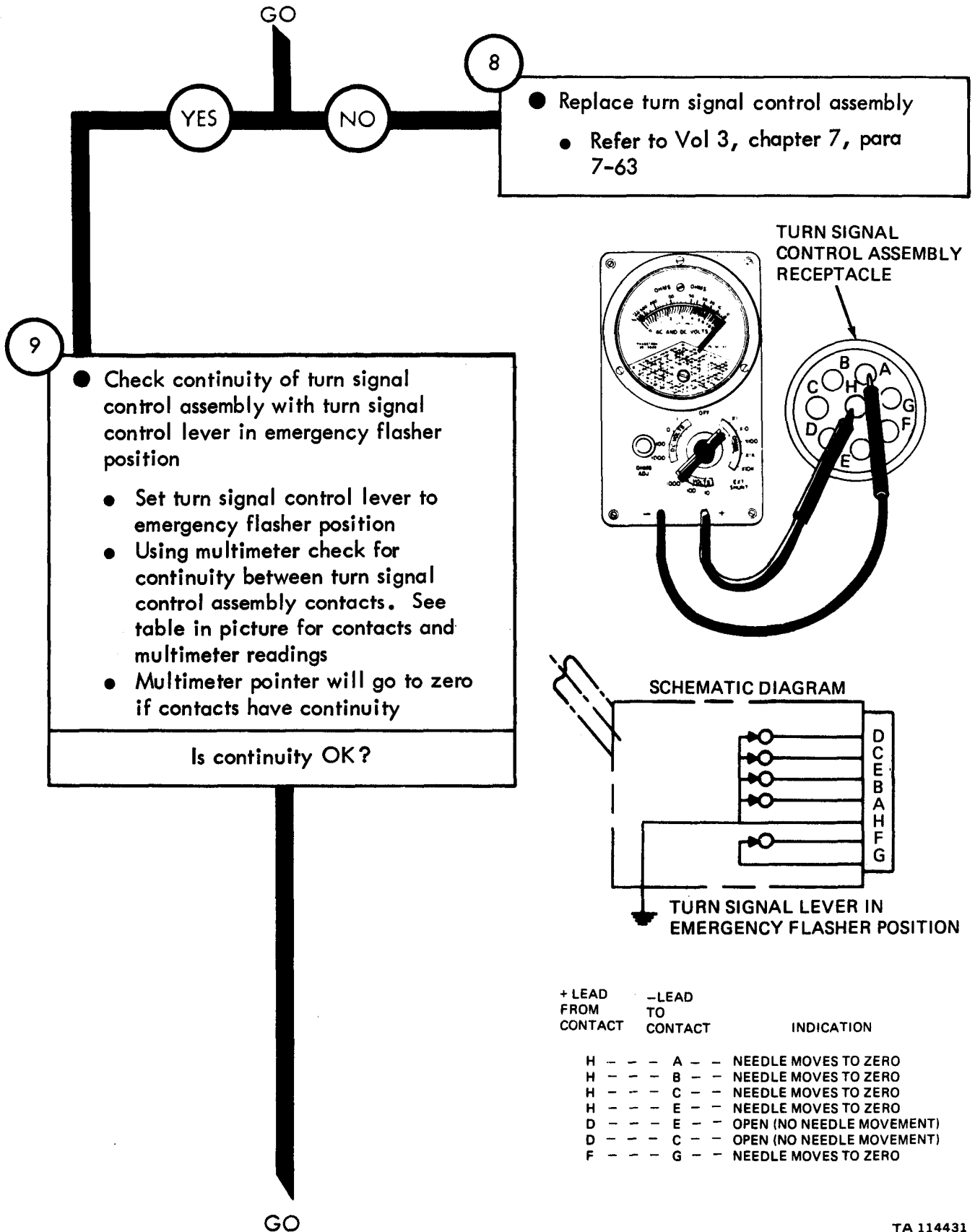

Figure 25-26 (Sheet 5 of 6)

TA 114431

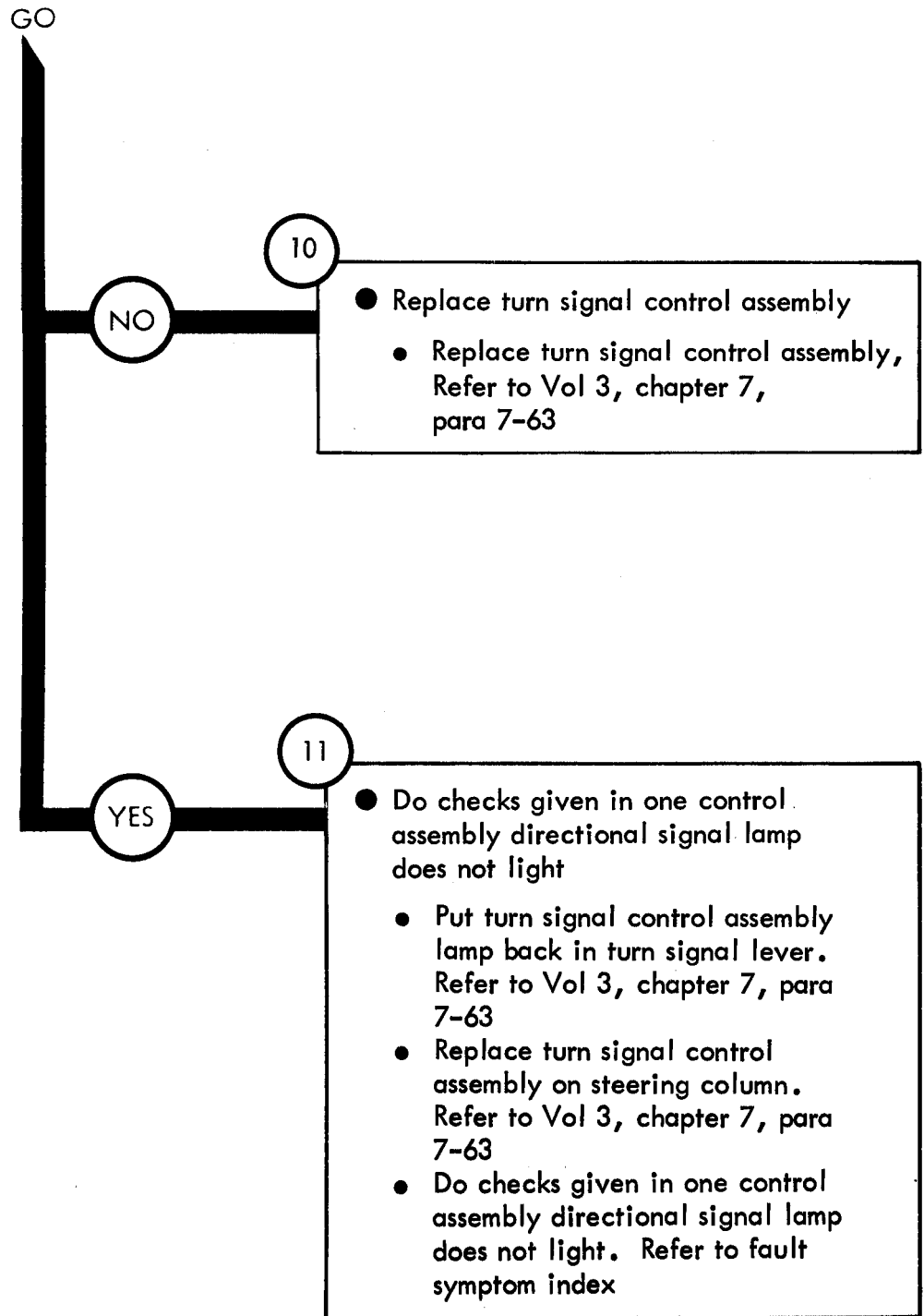

Figure 25-26 (Sheet 6 of 6)

Symptom

27 CONTROL ASSEMBLY DIRECTIONAL SIGNAL LIGHT DOES NOT FLASH, REST OF DIRECTIONAL SIGNAL SYSTEM WORKS

1

- Park truck
- Refer to TM 9-2320-209-10

2

- Test turn signal control assembly for ground to steering column
- Try to push turn signal control assembly around steering column

Does turn signal control assembly move?

GO

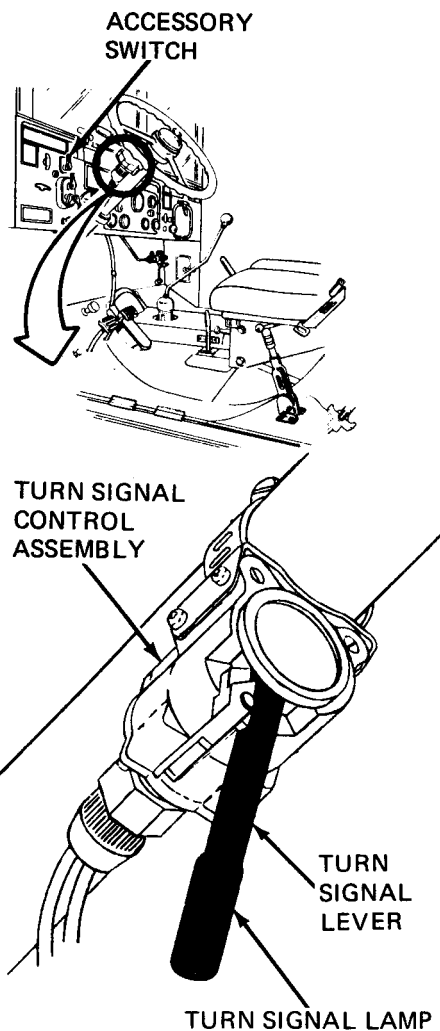
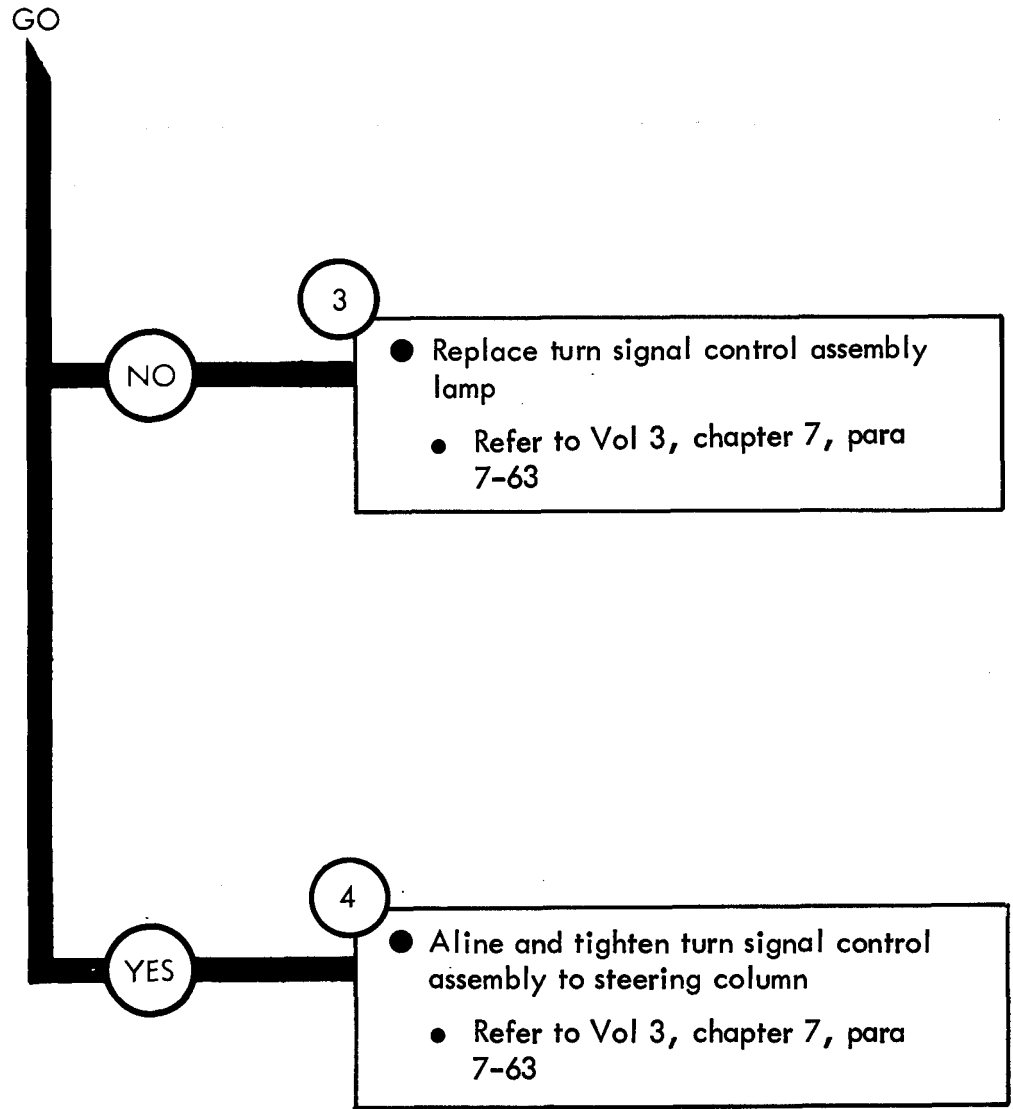

Figure 25-27 (Sheet 1 of 2)



Symptom

28

FUEL LEVEL GAGE DOES NOT WORK,
ALL OTHER GAGES WORK

NOTE

When checking voltage +24 volts DC
means a range of +23 to +26 volts DC

1

- Park truck
- Refer to TM 9-2320-209-10

GO

TA 114435

Figure 25-28 (Sheet 1 of 9)

GO

2

- Check for +2 to +4 volts from fuel level gage to fuel sending unit
- Set ACCESSORY switch to OFF
- Take off lead 28 contact from fuel sending unit
- Set ACCESSORY switch to ON

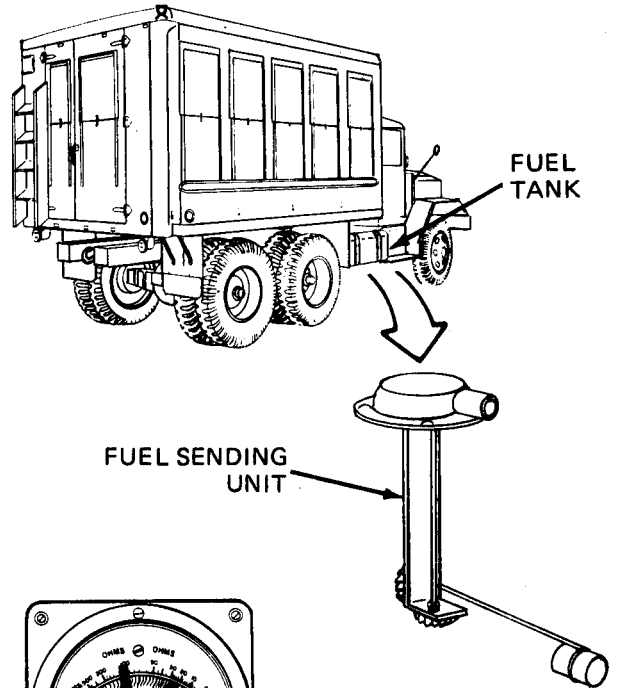

- Set multimeter to measure +24 volts DC
- Refer to test equipment procedures index
- Put multimeter - lead on a good ground
- Put multimeter + lead on lead 28 contact
- Read multimeter. Multimeter should measure +24 volts DC

Does multimeter measure less than 10 volts DC?

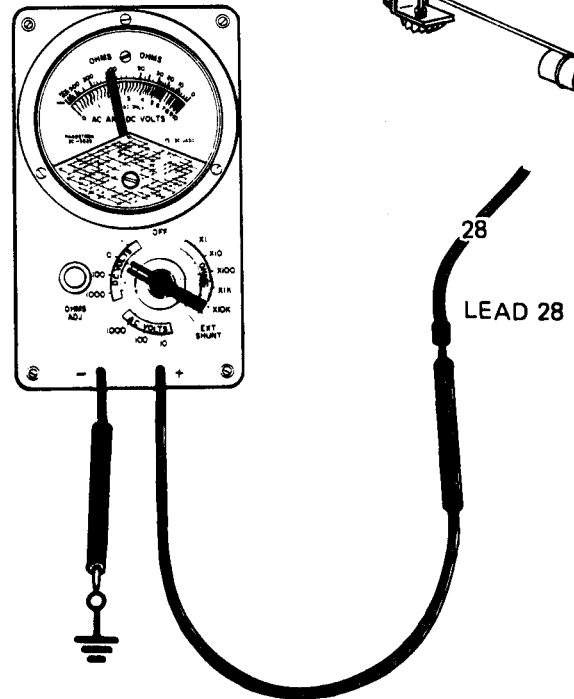

YES

NO

3

- Replace fuel level gage
- Set ACCESSORY switch to OFF
- Put lead 28 contact back on fuel sending unit
- Replace fuel level gage. Refer to Vol 3, chapter 7, para 7-13

GO

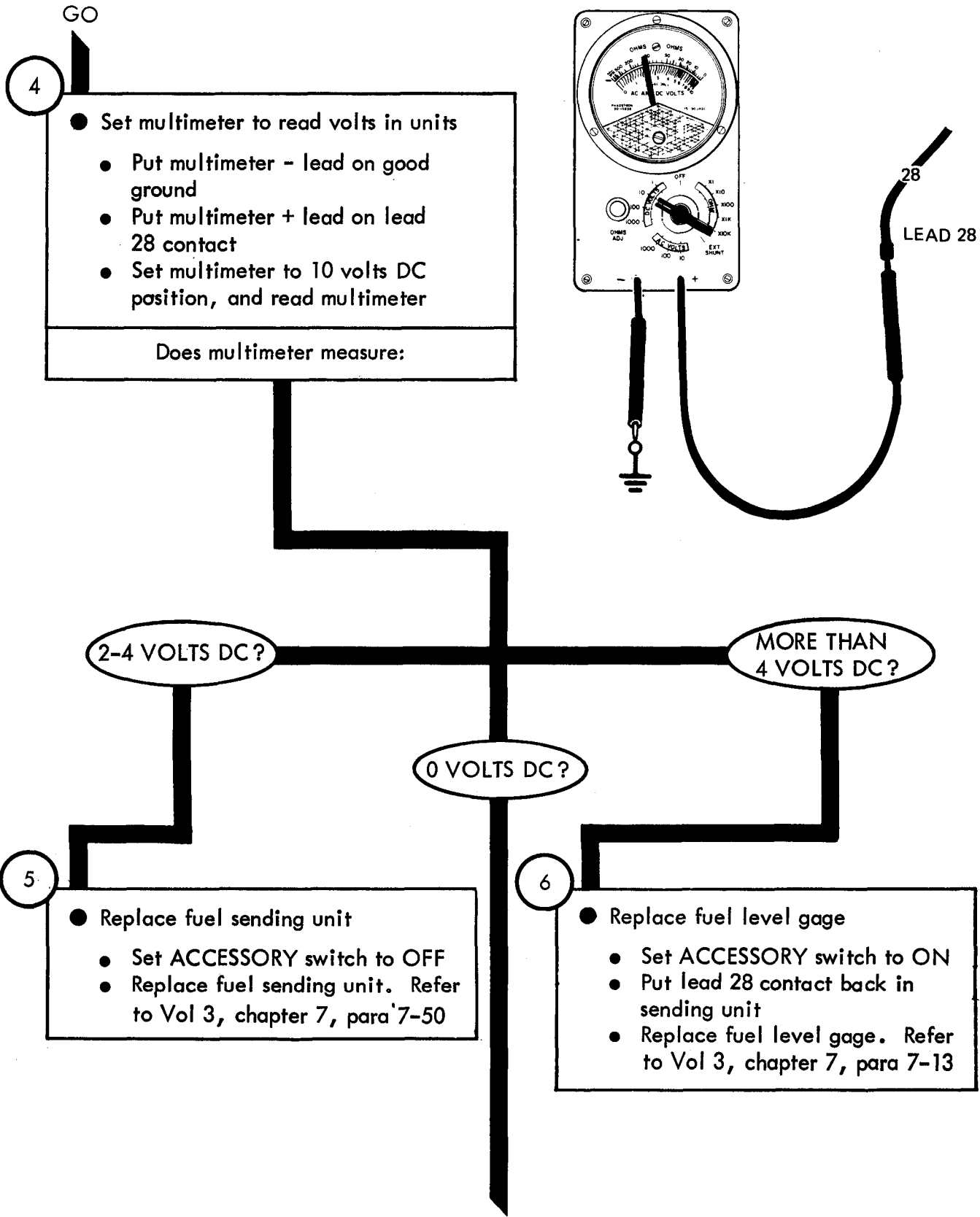
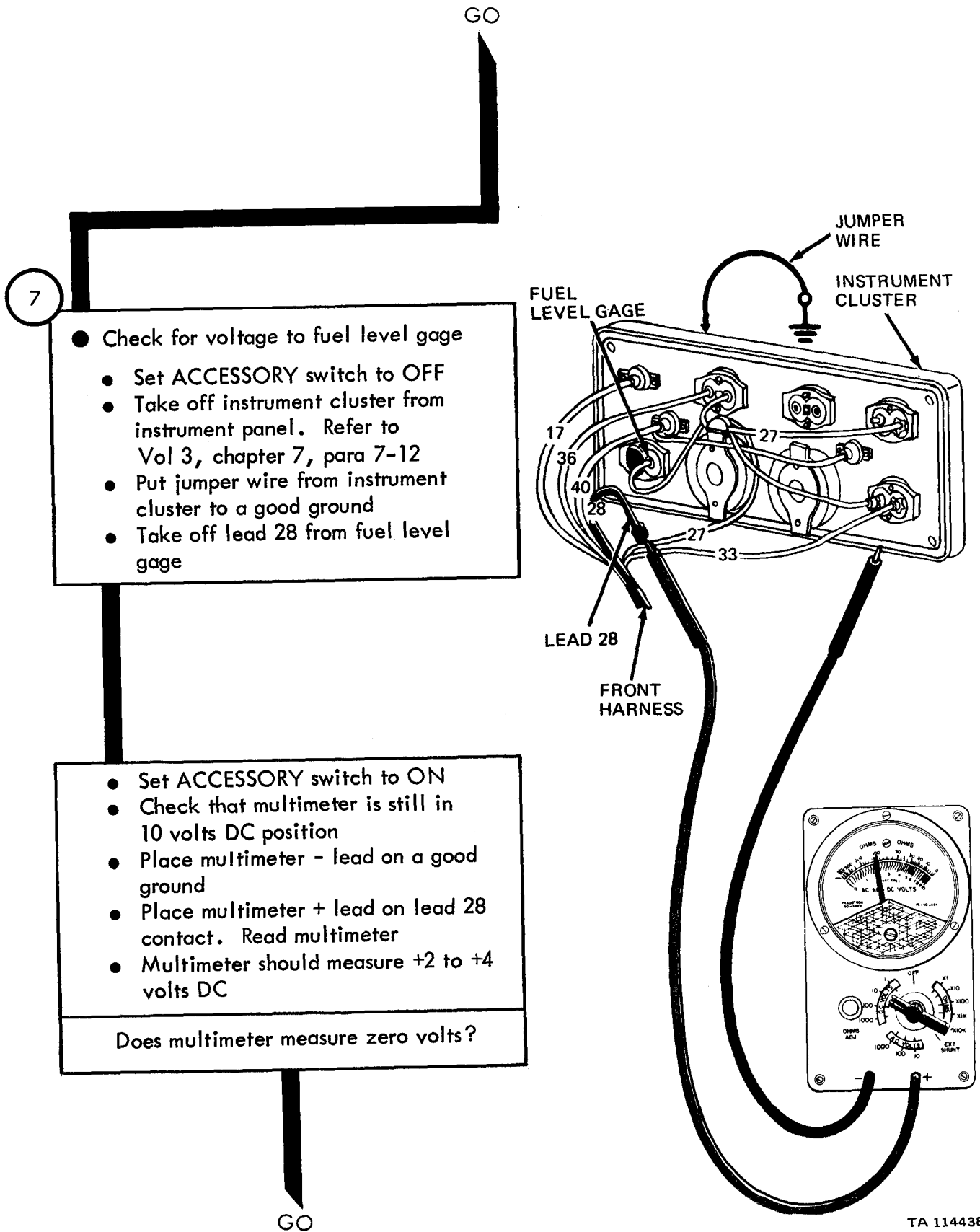

Figure 25-28 (Sheet 3 of 9)

TA 114437



7

- Check for voltage to fuel level gage
 - Set ACCESSORY switch to OFF
 - Take off instrument cluster from instrument panel. Refer to Vol 3, chapter 7, para 7-12
 - Put jumper wire from instrument cluster to a good ground
 - Take off lead 28 from fuel level gage

- Set ACCESSORY switch to ON
- Check that multimeter is still in 10 volts DC position
- Place multimeter - lead on a good ground
- Place multimeter + lead on lead 28 contact. Read multimeter
- Multimeter should measure +2 to +4 volts DC

Does multimeter measure zero volts?

GO

TA 114438

Figure 25-28 (Sheet 4 of 9)

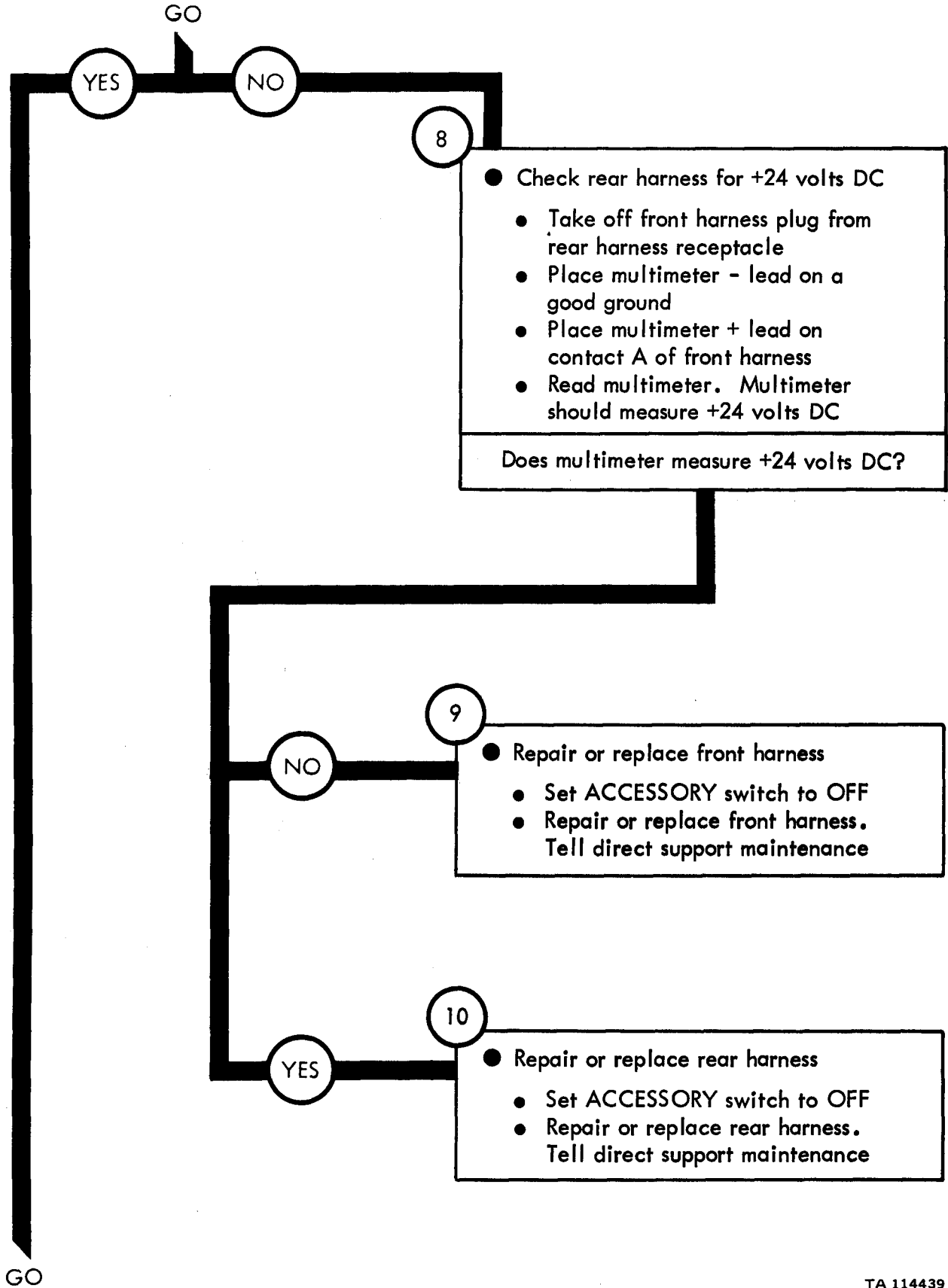
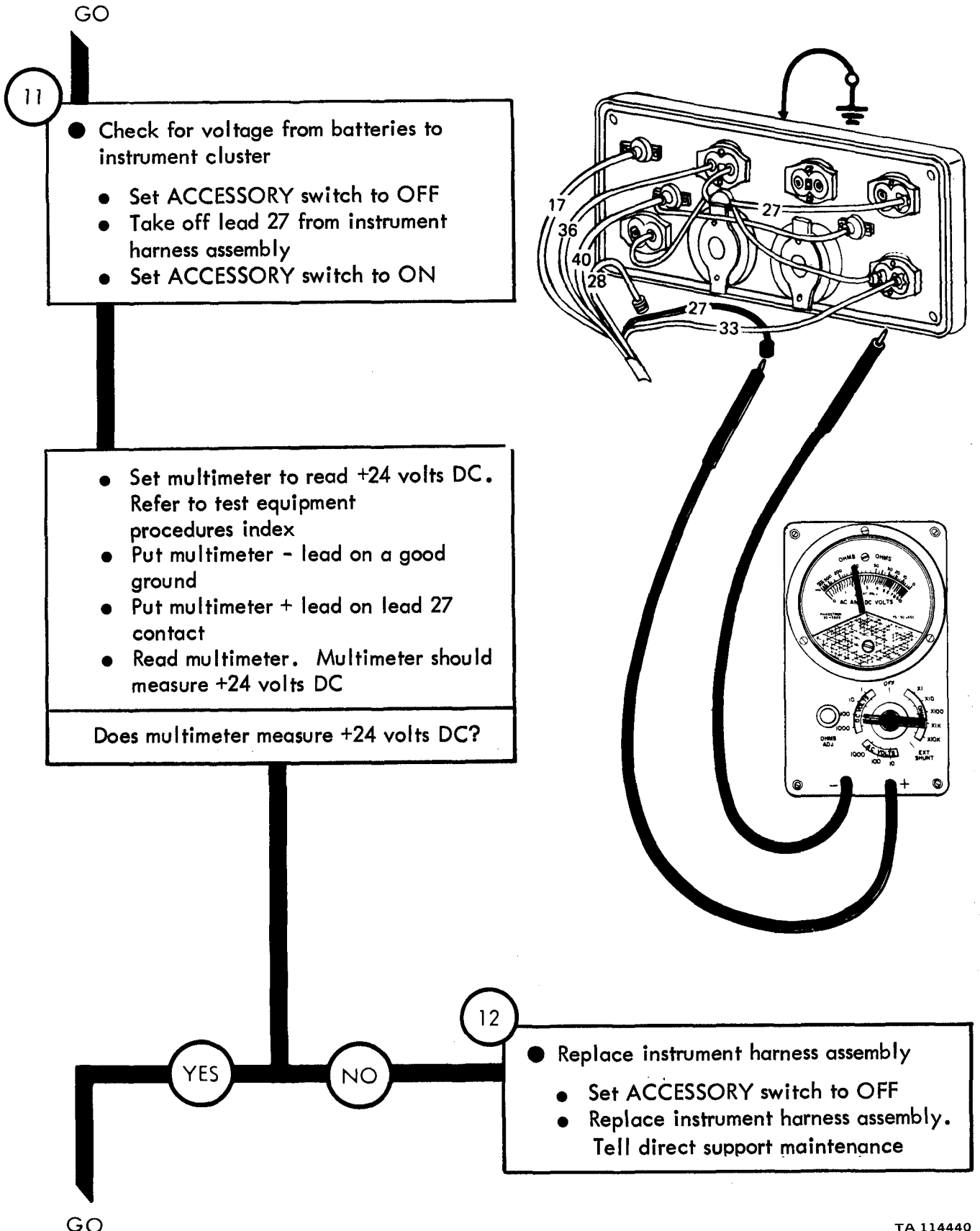

Figure 25-28 (Sheet 5 of 9)



TA 114440

Figure 25-28 (Sheet 6 of 9)

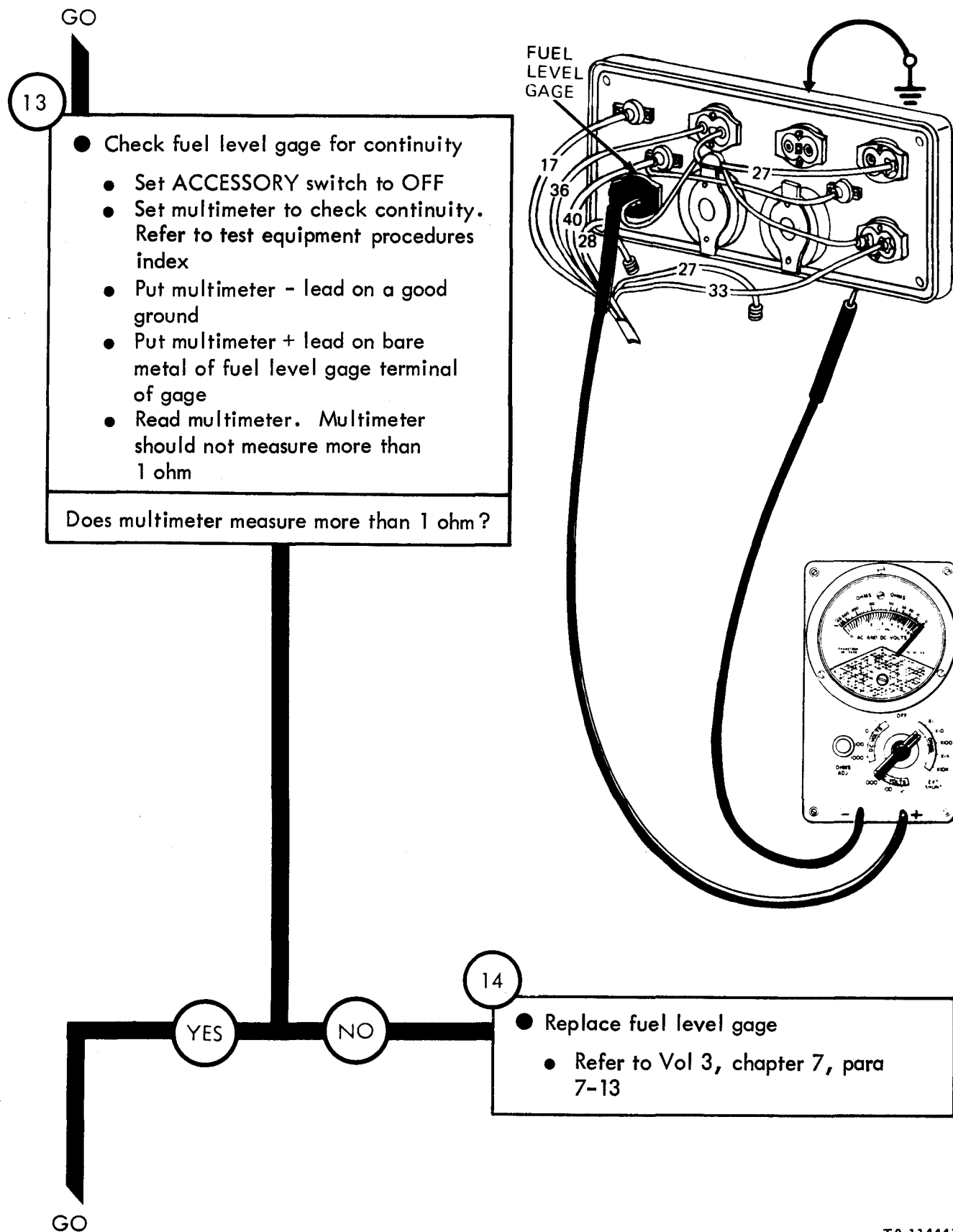

Figure 25-28 (Sheet 7 of 9)

TA 114441

15

- Clean surfaces where fuel level gage and instrument cluster contact, and recheck continuity
- Take off fuel level gage from instrument cluster. Refer to Vol 3, chapter 7, para 7-13
- Clean surfaces where fuel level gage and instrument cluster contact.
- Put fuel level gage back on instrument cluster. Refer to Vol 3, chapter 7, para 7-13

- Put multimeter - lead on a good ground
 - Put multimeter + lead on fuel level gage terminal 28
 - Read multimeter. Multimeter should measure zero ohms
- Does multimeter measure zero ohms?

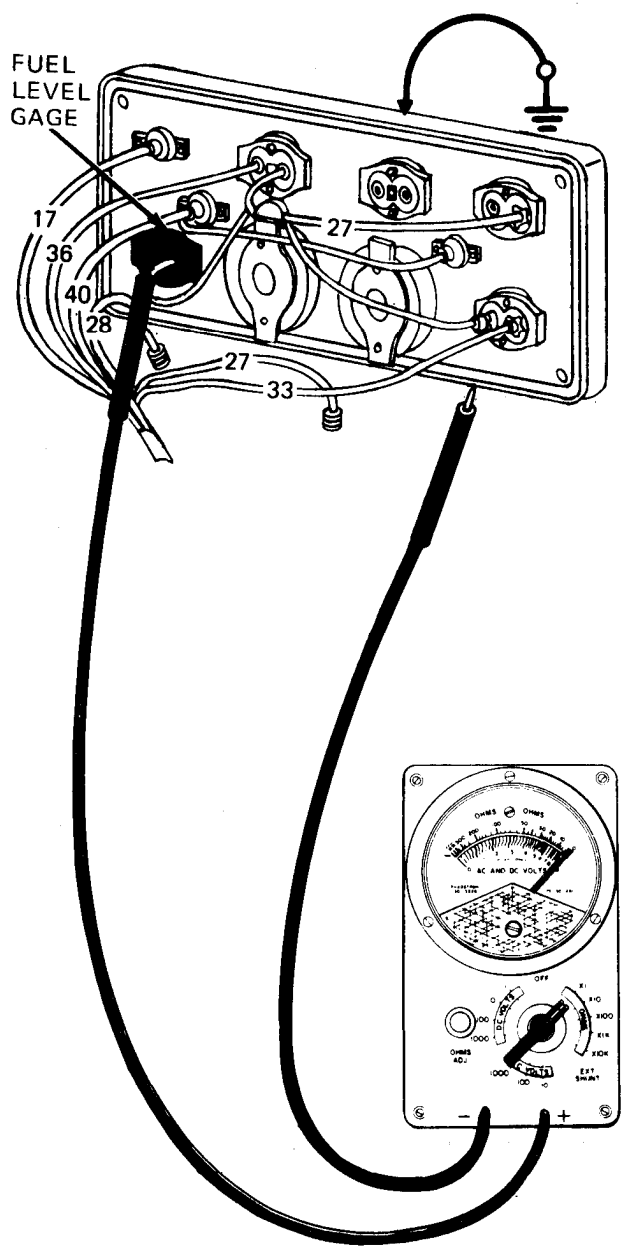

GO

Figure 25-28 (Sheet 8 of 9)

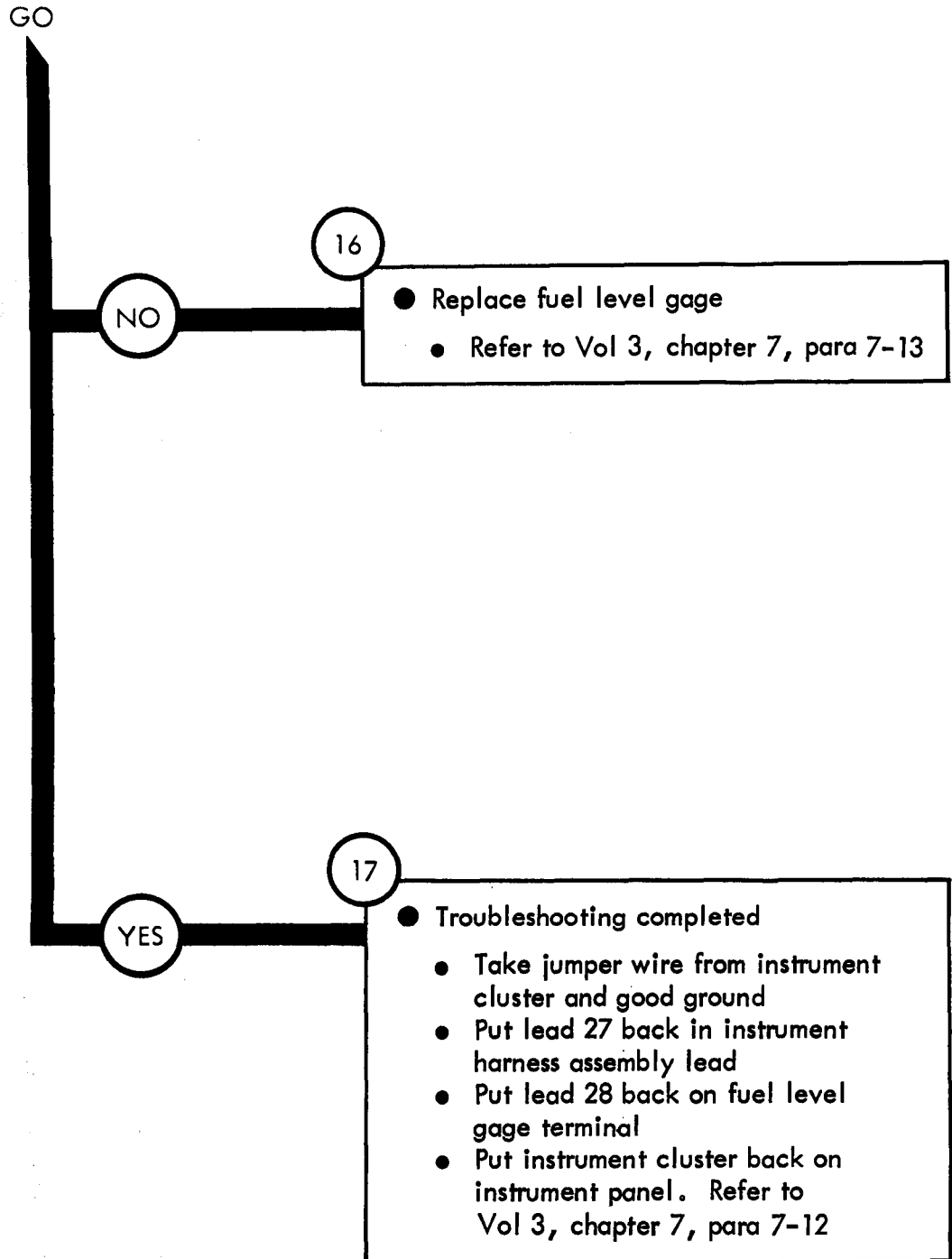

Figure 25-28 (Sheet 9 of 9)

Symptom

29 TEMPERATURE GAGE DOES NOT WORK. ALL OTHER GAGES WORK

NOTE

When measuring voltage +24 volts means a range of +23 to +26 volts DC

1

- Park truck
- Refer to TM 9-2320-209-10

2

- Check for +24 volts from temperature gage to sending unit
 - Set ACCESSORY switch to OFF
 - Take off lead 33 contact from temperature sending unit
 - Set ACCESSORY switch to ON

- Set **multimeter** to measure +24 volts DC. Refer to test equipment procedures index
- Put **multimeter** - lead on a good ground
- Put **multimeter** + lead on lead 33 contact
- Read **multimeter**. **Multimeter** should read +24 volts DC

Does **multimeter** measure less than +24 volts DC?

GO

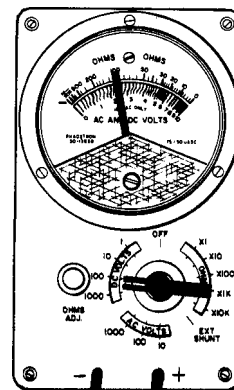
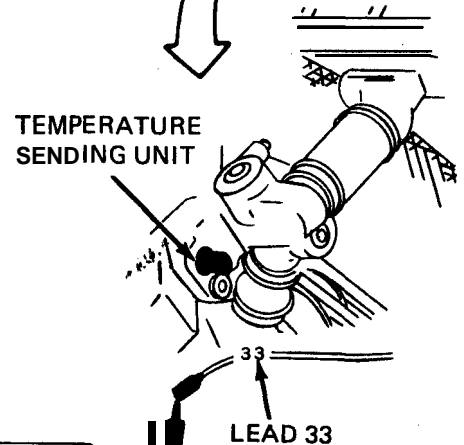
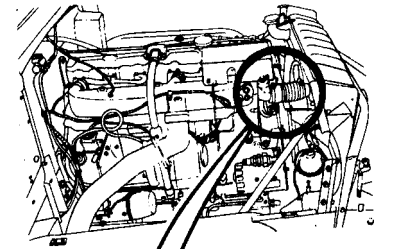

Figure 25-29 (Sheet 1 of 6)

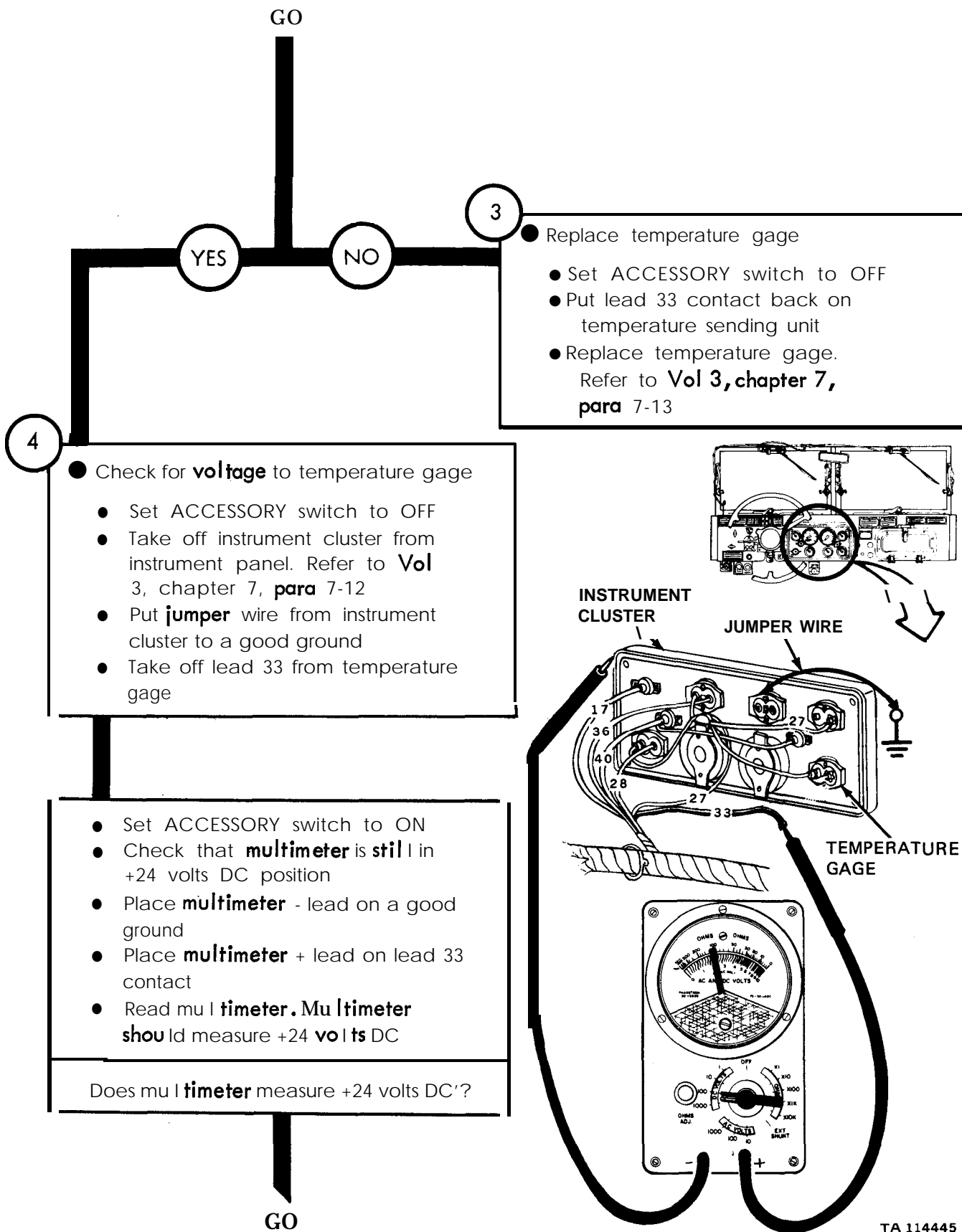

Figure 25-29 (Sheet 2 of 6)

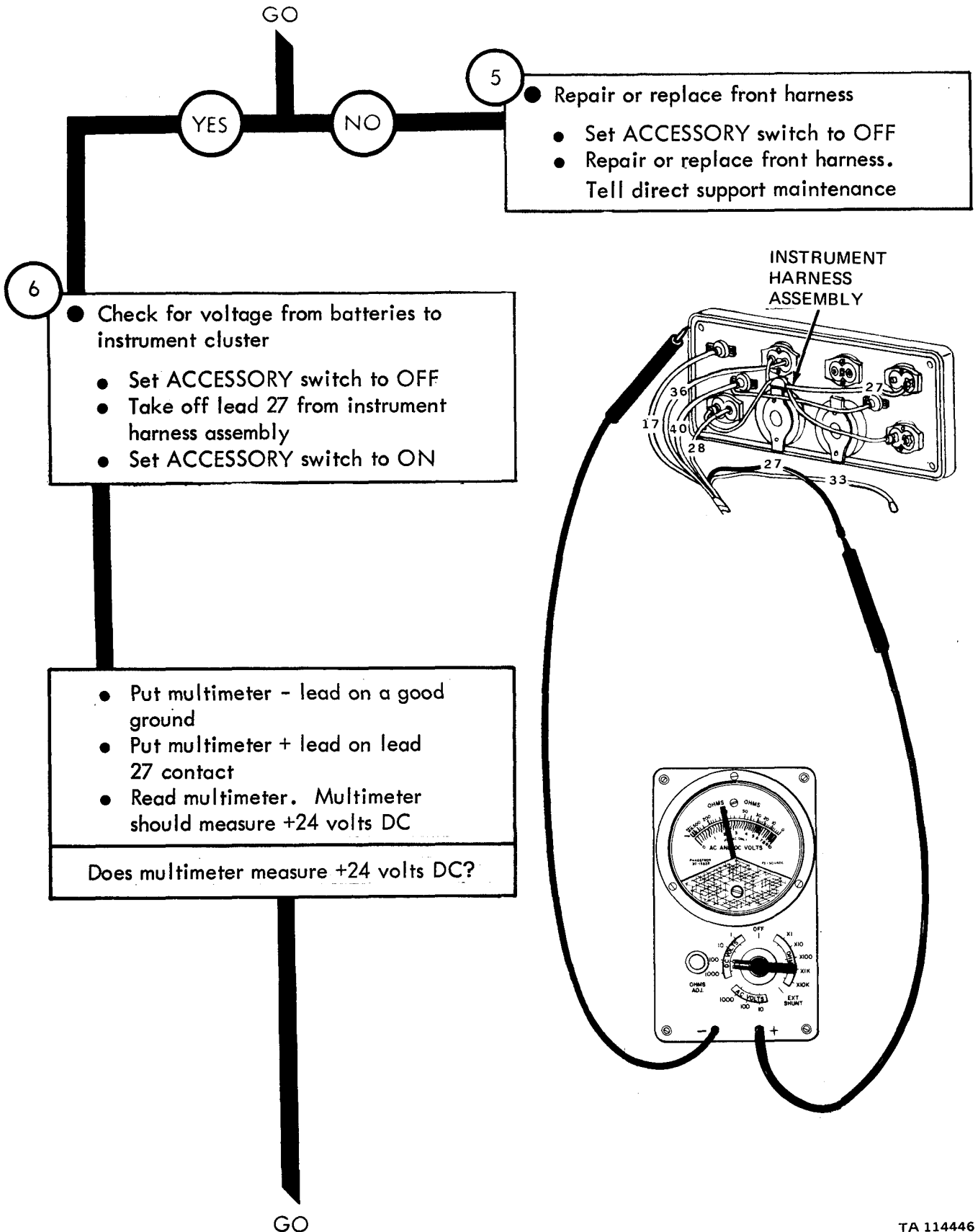

Figure 25-29 (Sheet 3 of 6)

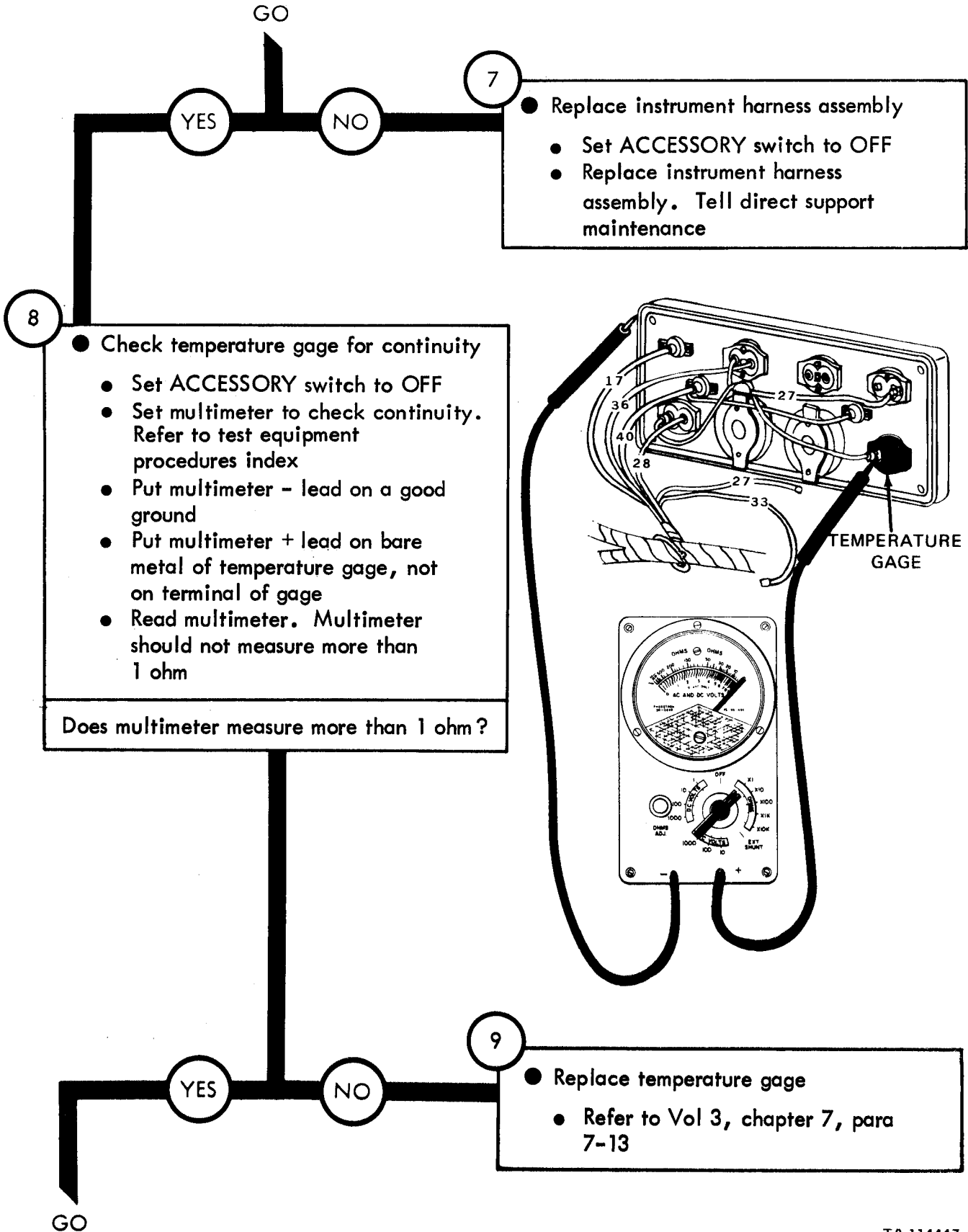

Figure 25-29 (Sheet 4 of 6)

TA 114447

GO

10

- Clean surfaces where temperature gage and instrument cluster contact, and recheck continuity
- Take off temperature gage from instrument cluster. Refer to Vol 3, chapter 7, para 7-13
- Clean surfaces where temperature gage and instrument cluster contact.
- Put temperature gage back on instrument cluster. Refer to Vol 3, chapter 7, para 7-13

- Put multimeter - lead on a good ground
- Put multimeter + lead on temperature gage lead 33 terminal
- Read multimeter. Multimeter should measure zero ohms

Does multimeter measure zero ohms?

GO

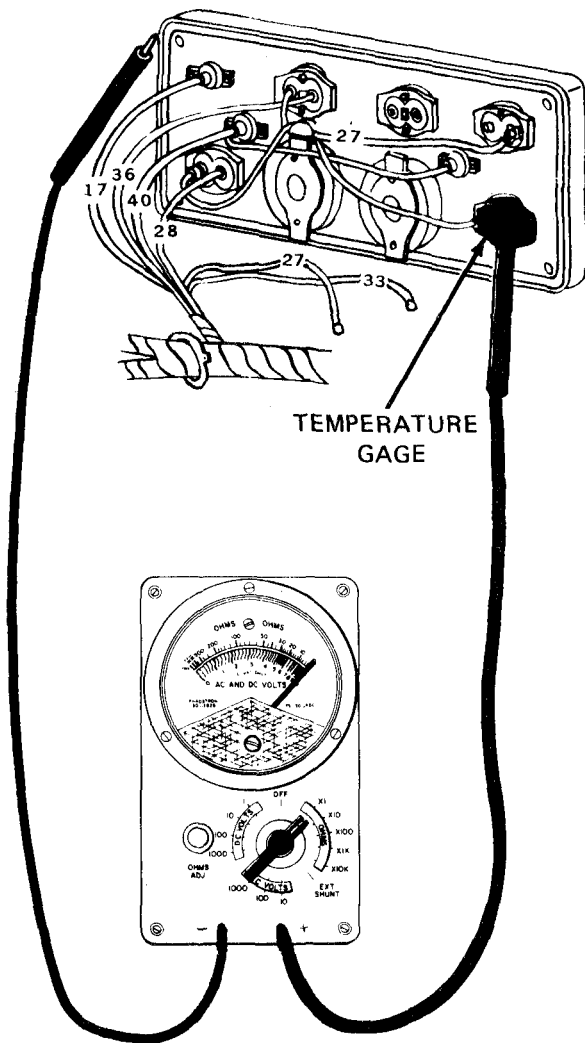

Figure 25-29 (Sheet 5 of 6)

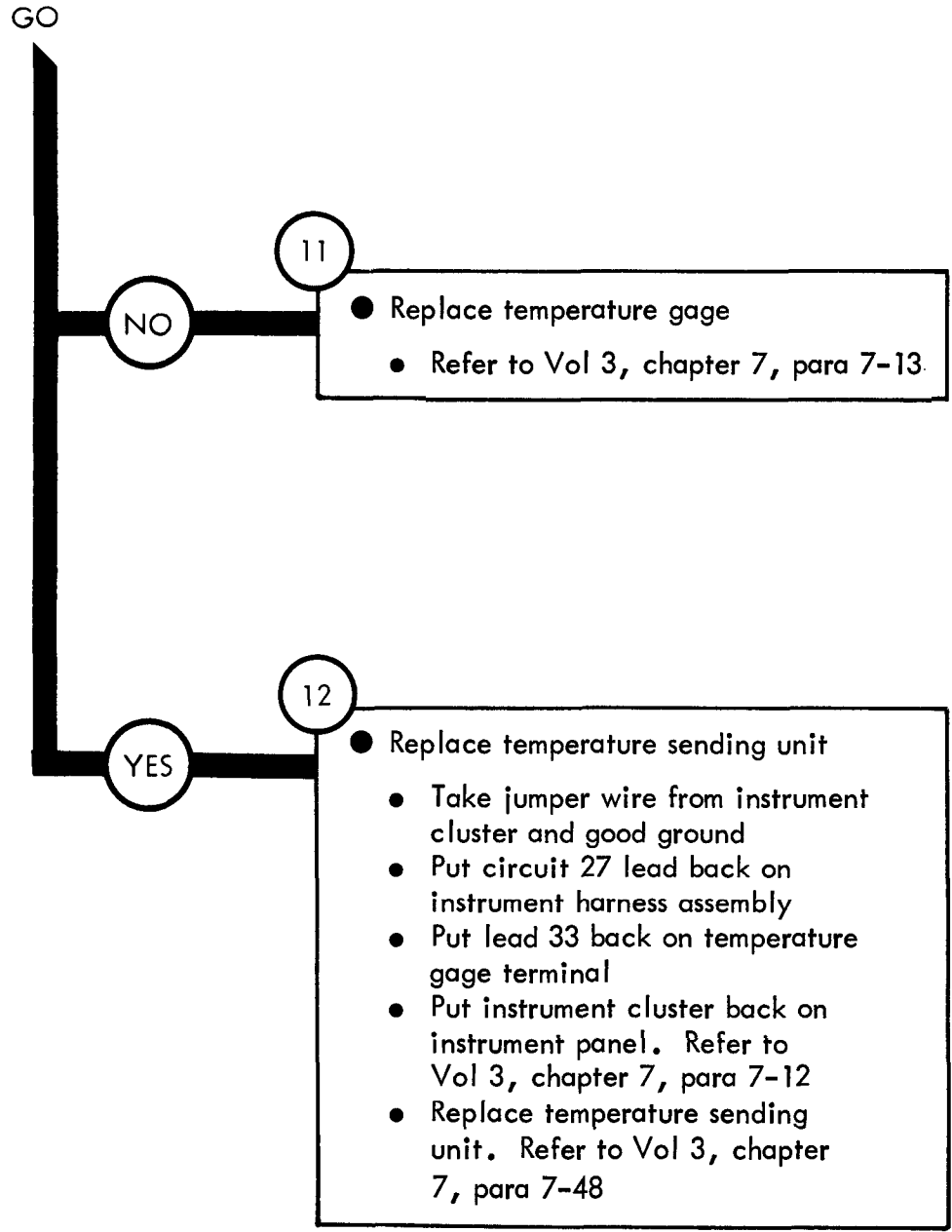

Figure 25-29 (Sheet 6 of 6)

Symptom

30

OIL PRESSURE GAGE DOES NOT WORK. ALL OTHER GAGES WORK

NOTE

When checking voltage +24 volts DC means a range of +23 to +26 volts DC

1

- Park truck
- Refer to TM 9-2320-209-10

GO

Figure 25-30 (Sheet 1 of 7)

GO

2

- Check for +24 volts from oil pressure gage to oil sending unit
- Set ACCESSORY switch to OFF
- Take off lead 36 contact from oil pressure sending unit
- Set ACCESSORY switch to ON

- Set multimeter to measure +24 volts DC. Refer to test equipment procedures index
- Put multimeter - lead on a good ground
- Put multimeter + lead on lead 36 contact
- Read multimeter

Does multimeter measure less than 10 volts DC?

GO

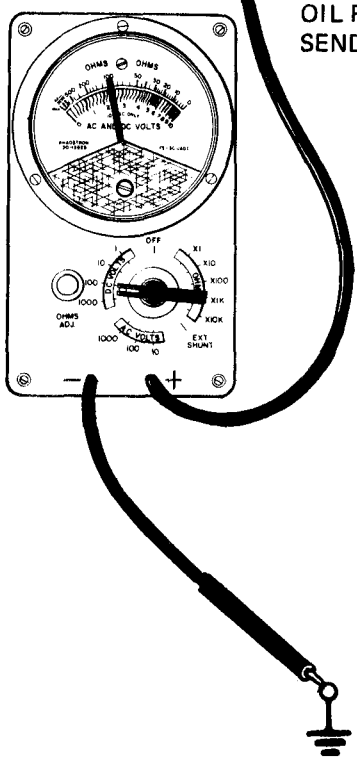
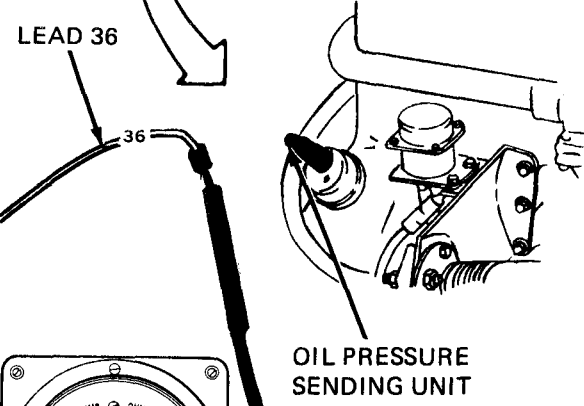
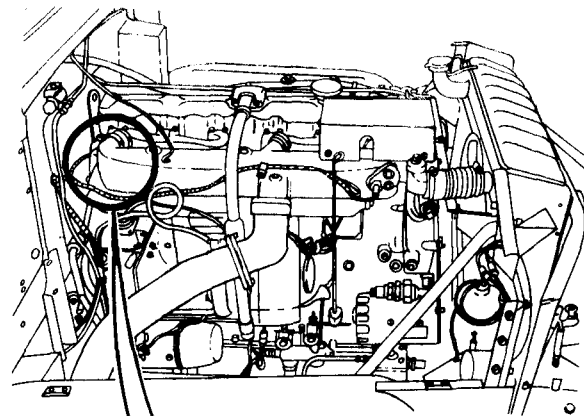

Figure 25-30 (Sheet 2 of 7)

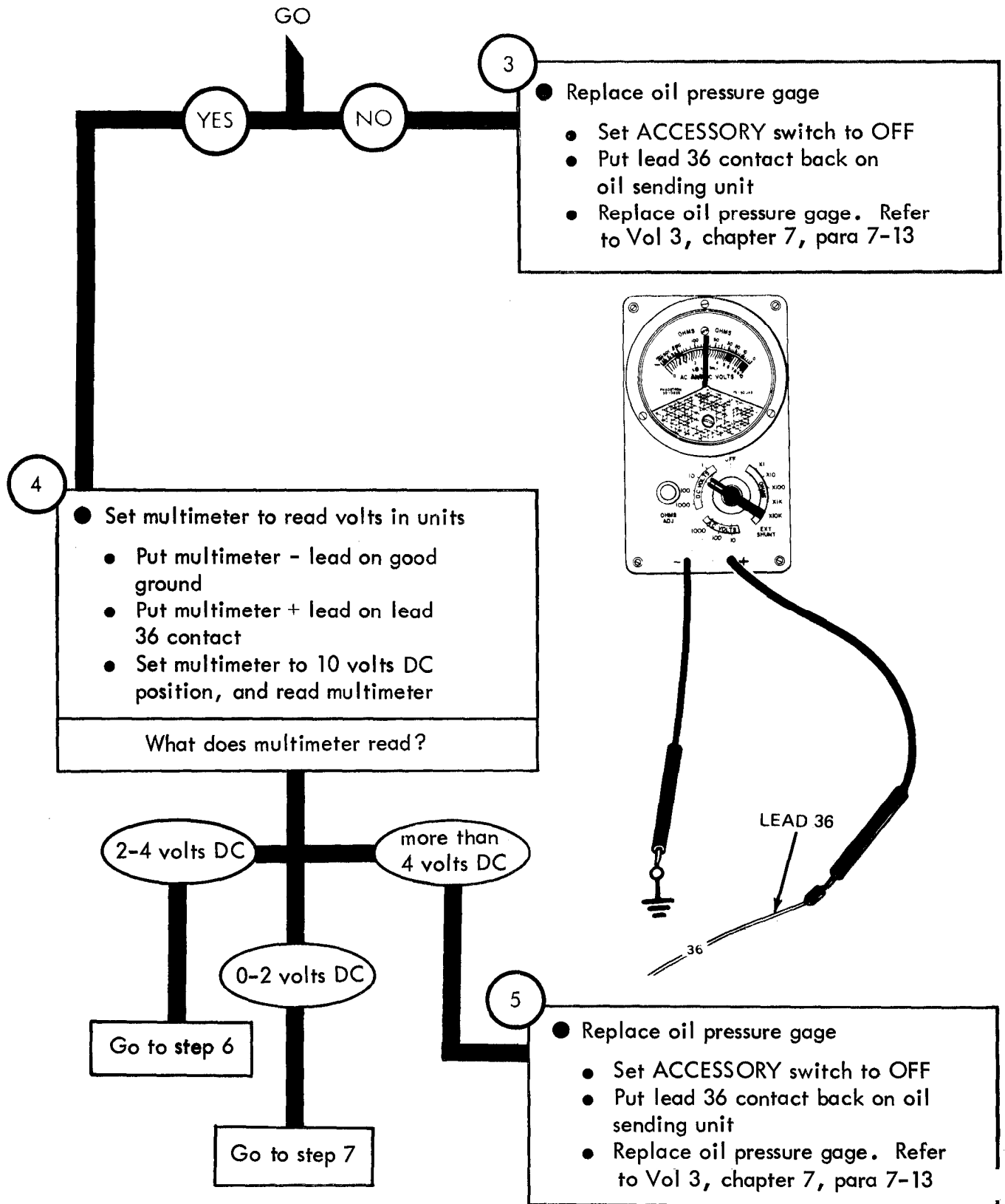

Figure 25-30 (Sheet 3 of 7)

GO

6

- Replace oil pressure sending unit
 - Set ACCESSORY switch to OFF
 - Replace oil pressure sending unit. Refer to Vol 3, chapter 7, para 7-49

From step 4

7

- Check for voltage through oil pressure gage
 - Set ACCESSORY switch to OFF
 - Take off instrument cluster from instrument panel. Refer to Vol 3, chapter 7, para 7-12
 - Put jumper wire from instrument cluster to a good ground
 - Take off lead 36 from oil pressure gage

- Set ACCESSORY switch to ON
- Check that multimeter is still in 10 volt DC position
- Place multimeter - lead on a good ground
- Place multimeter + lead on lead 36 contact. Read multimeter
- Multimeter should measure +2 to +4 volts DC

Does multimeter measure less than +2 volts DC?

GO

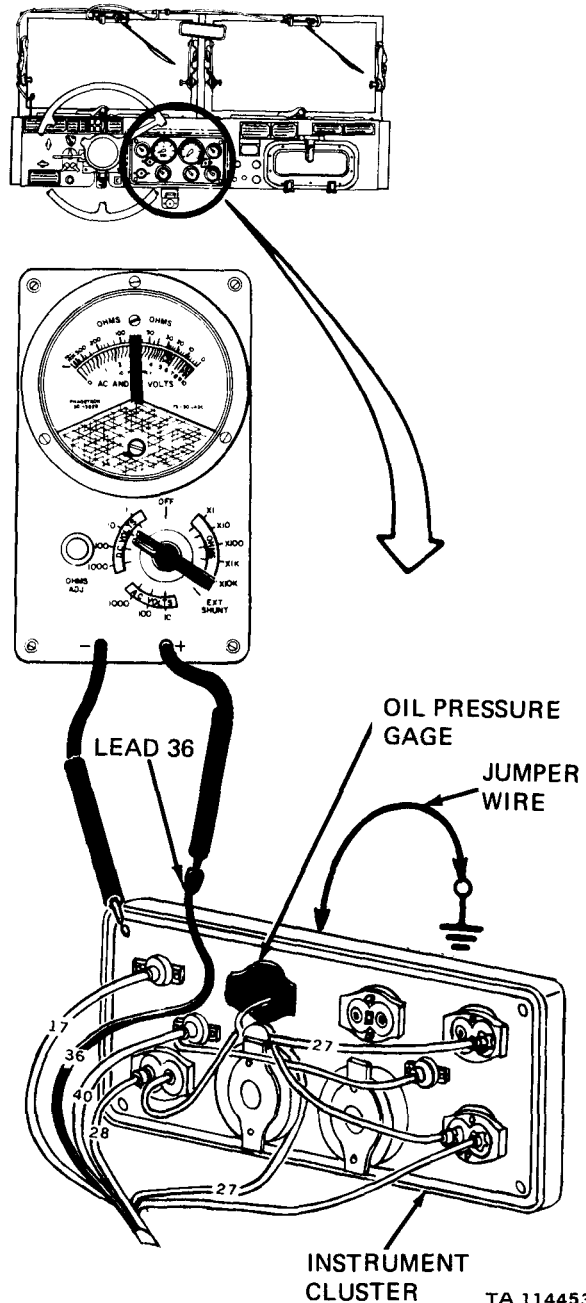

TA 114453

Figure 25-30 (Sheet 4 of 7)

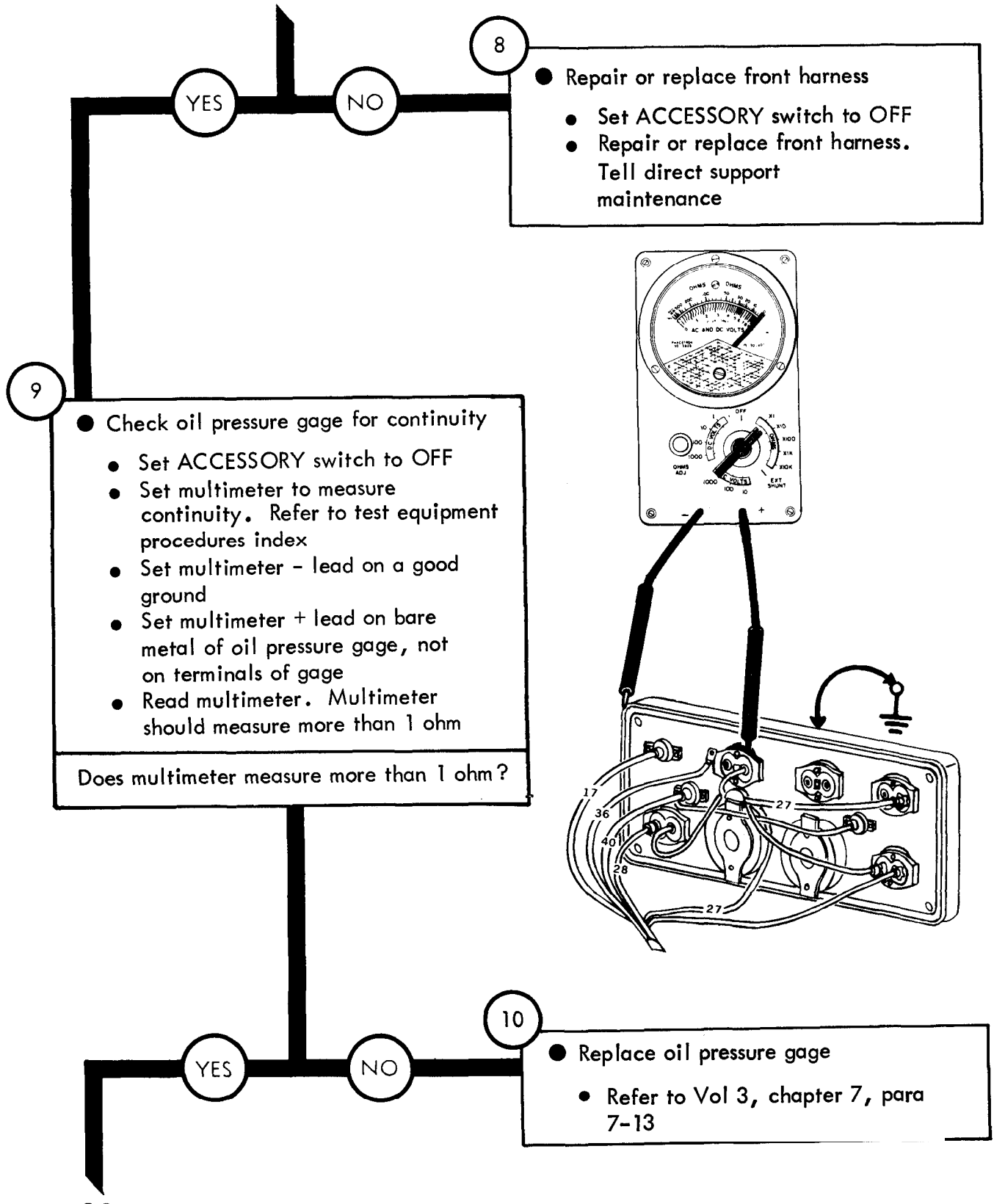

Figure 25-30 (Sheet 5 of 7)

GO

11

- Clean surfaces where oil pressure gage and instrument cluster contact, and recheck continuity
- Take off oil pressure gage from instrument cluster. Refer to Vol 3, chapter 7, para 7-13
- Clean surfaces where oil pressure gage and instrument cluster contact.
- Put oil pressure gage back on instrument cluster. Refer to Vol 3, chapter 7, para 7-13

- Put multimeter - lead on a good ground
- Put multimeter + lead on oil pressure gage lead 36 terminal
- Read multimeter. Multimeter should measure zero ohms

Does multimeter measure zero ohms?

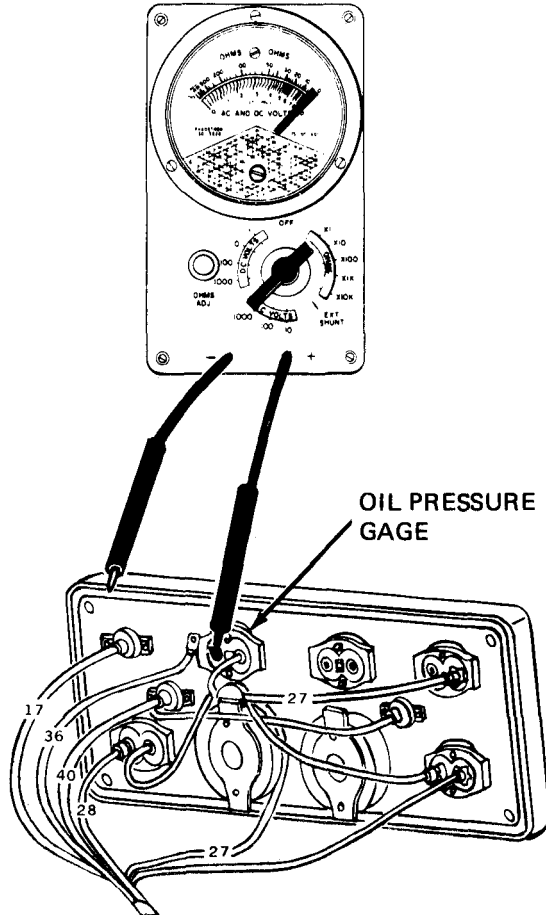

GO

Figure 25-30 (Sheet 6 of 7)

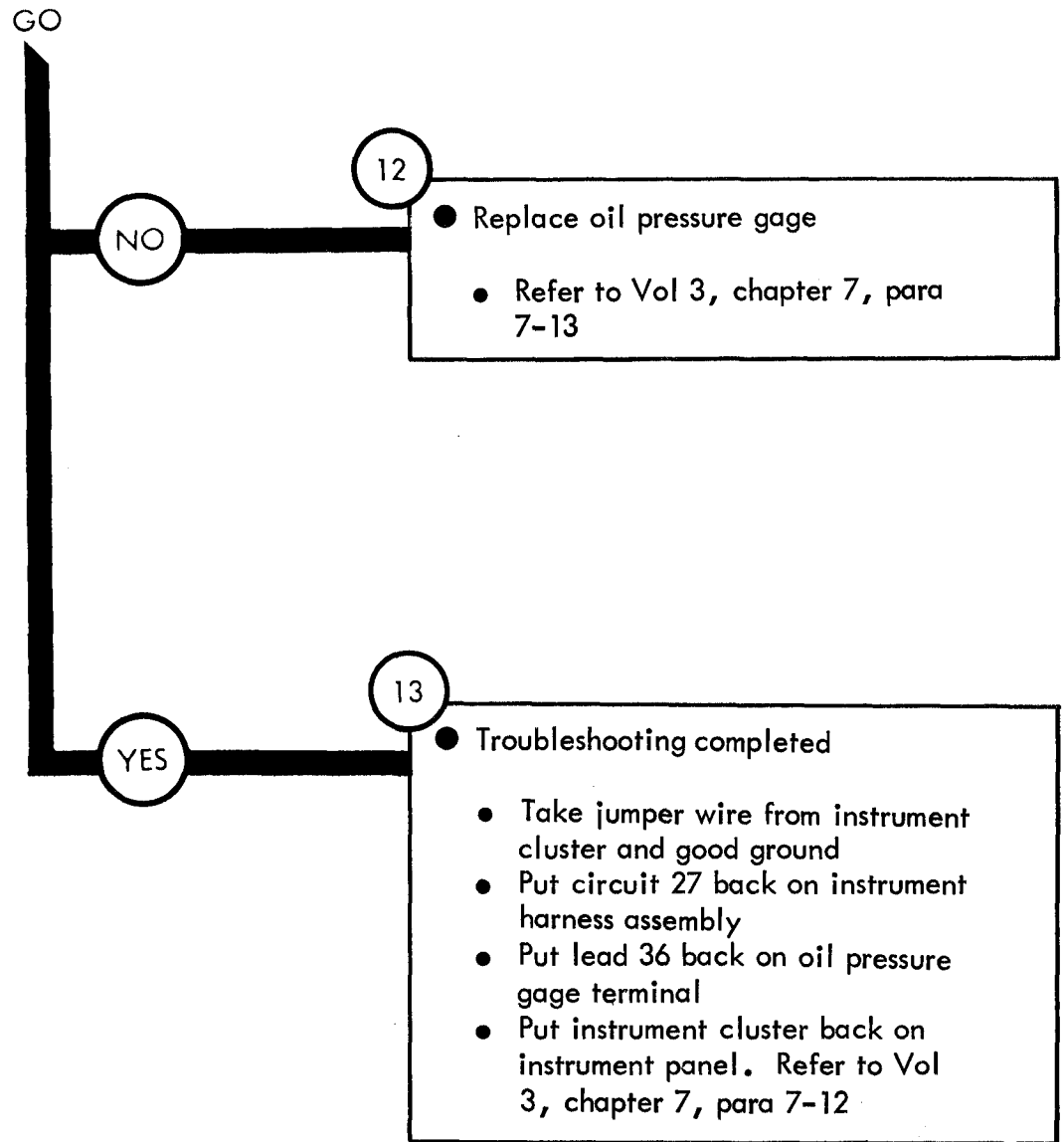

Figure 25-30 (Sheet 7 of 7)

Symptom

31 BATTERY-GENERATOR INDICATOR DOES NOT WORK
ALL OTHER GAGES WORK

NOTE

When checking voltage +24 volts DC means a range of +23 to +26 volts DC

1

- Park truck
- Refer to TM 9-2320-209-10

2

- Check for +24 volts DC to battery indicator
 - Set ACCESSORY switch to OFF
 - Take off instrument cluster from instrument panel. Refer to Vol 3, chapter 7, para 7-12
 - Put jumper wire between instrument panel and a good ground
 - Take off lead 27 contact from battery indicator terminal
 - Set ACCESSORY switch to ON

GO

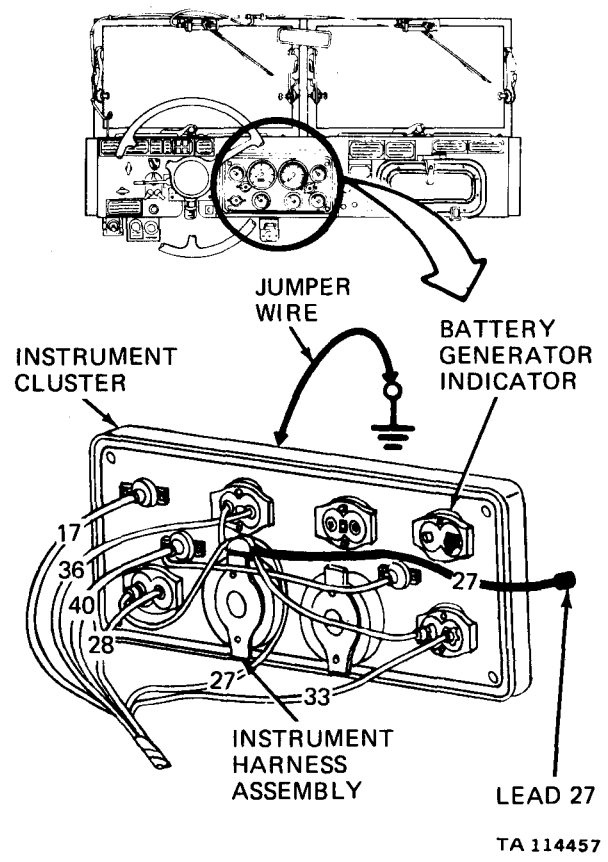

Figure 25-31 (Sheet 1 of 5)

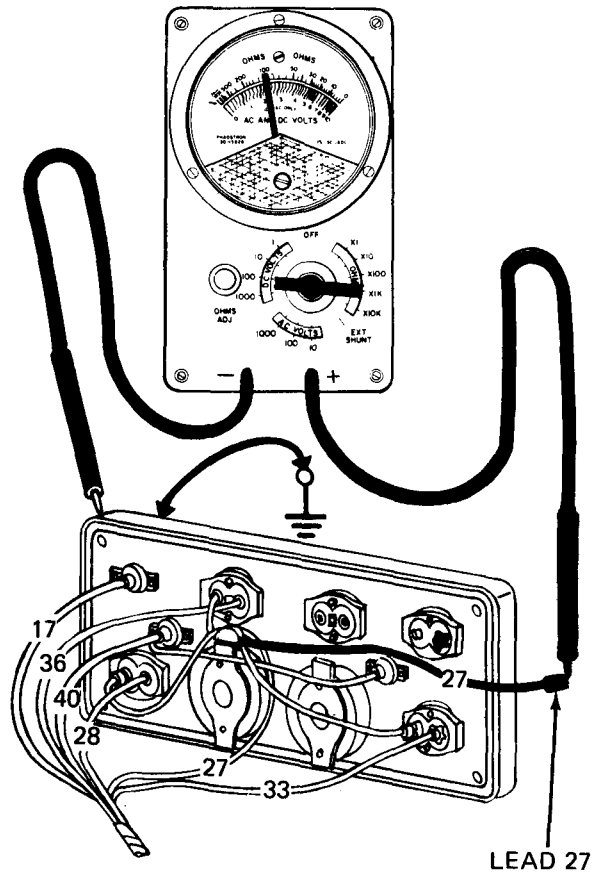
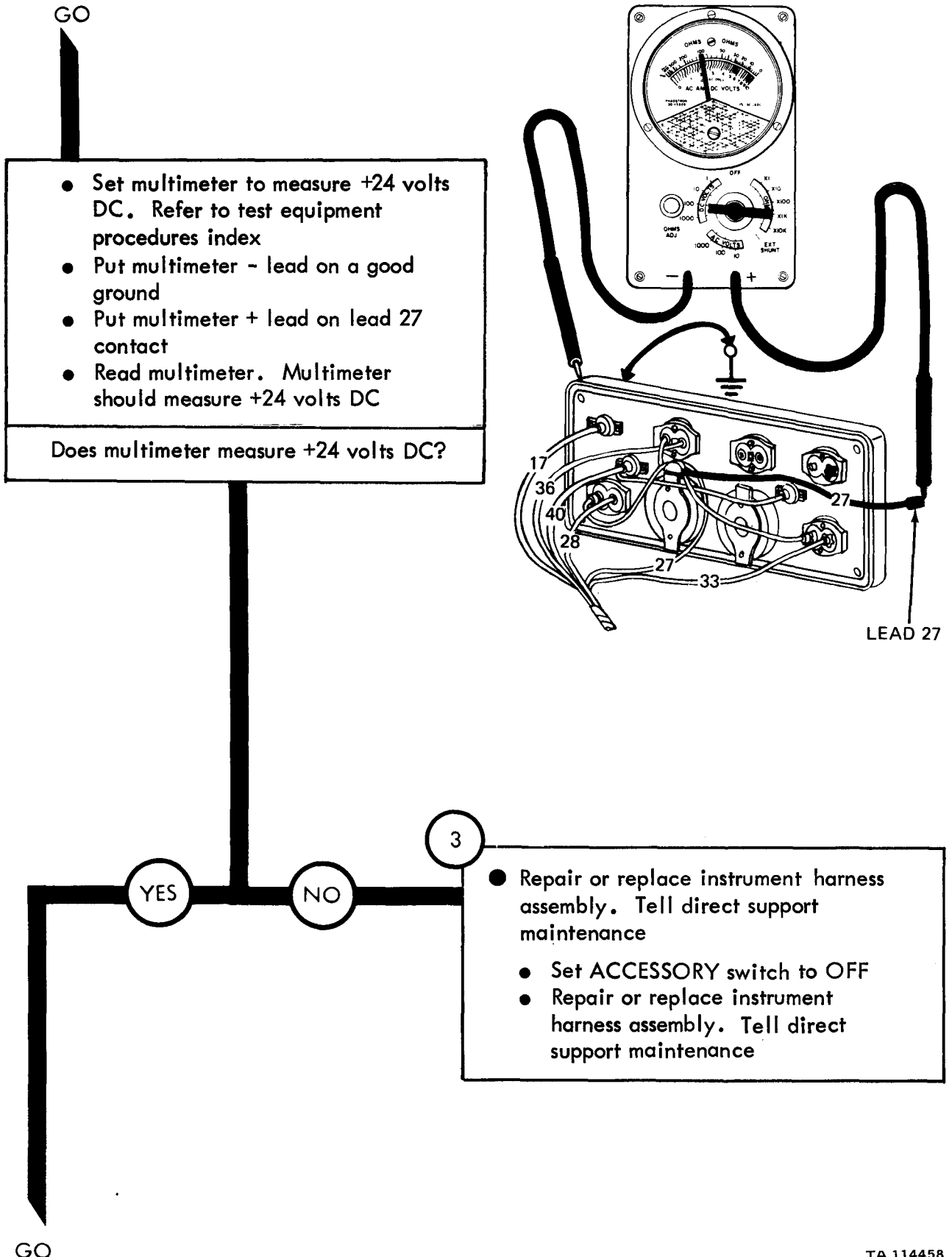
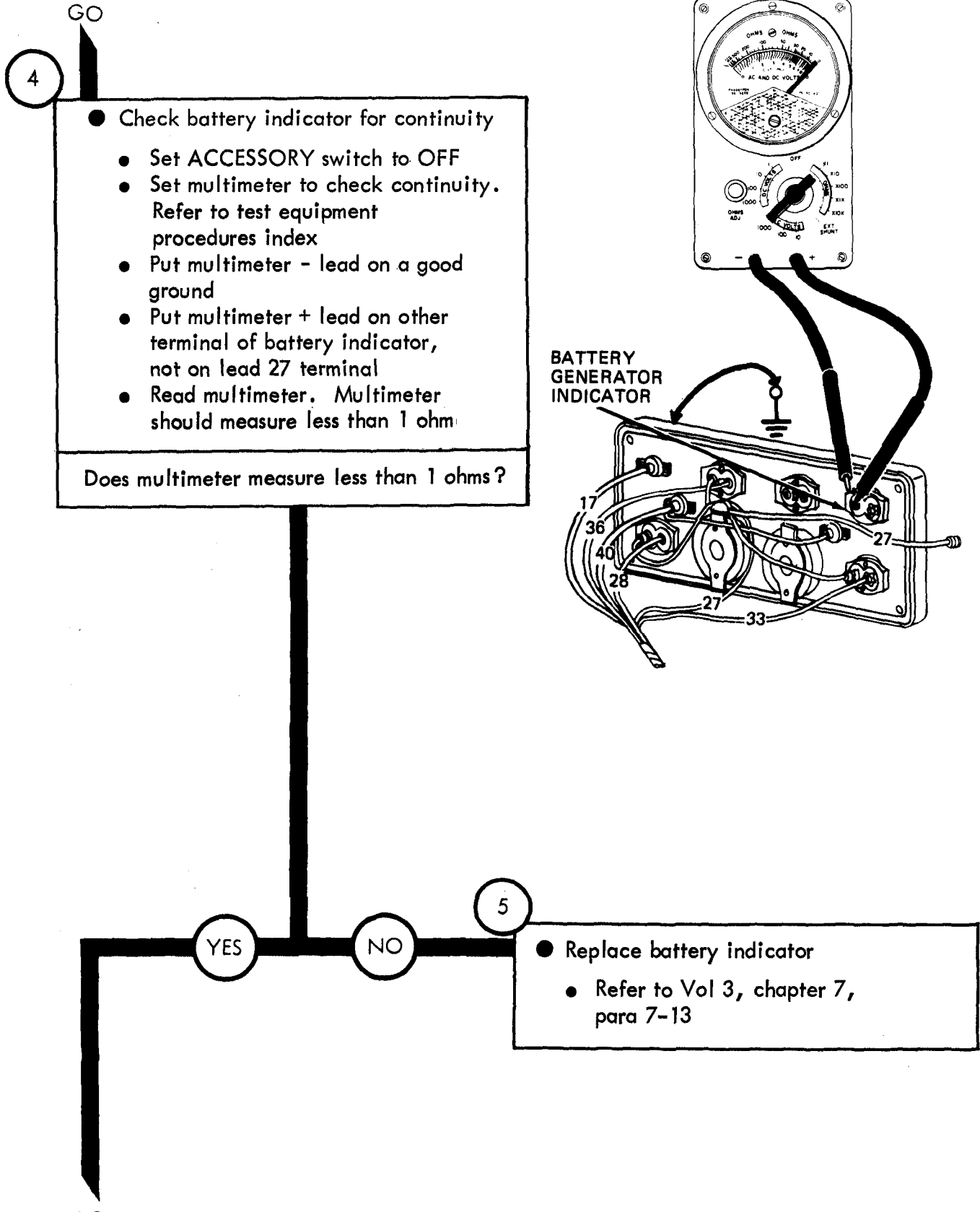

Figure 25-31 (Sheet 2 of 5)



TA 114459

Figure 25-31 (Sheet 3 of 5)

GO

6

- Clean surfaces where battery indicator and instrument cluster contact, and recheck continuity
- Take off battery indicator from instrument cluster. Refer to Vol 3, chapter 7, para 7-13
- Clean surfaces where battery indicator and instrument cluster contact
- Put battery indicator back on instrument cluster. Refer to Vol 3, chapter 7, para 7-13

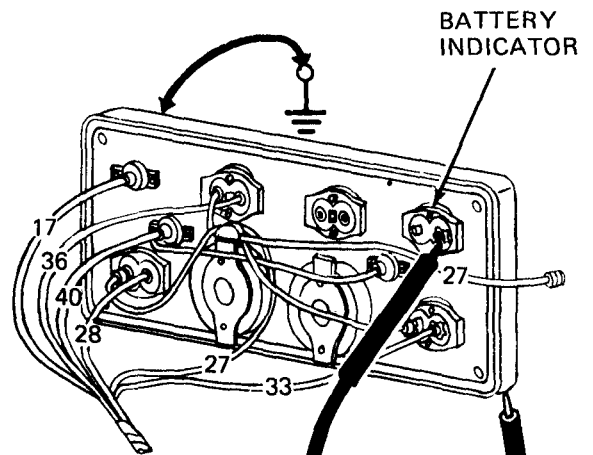

- Put multimeter - lead on a good ground
- Put multimeter + lead on battery indicator lead 27 contact terminal
- Read multimeter. Multimeter should measure less than 1 ohm

Does multimeter measure less than 1 ohm?

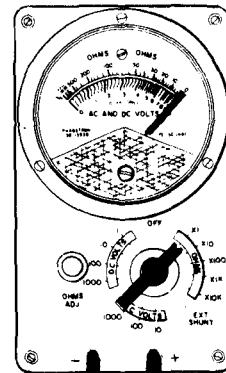

GO

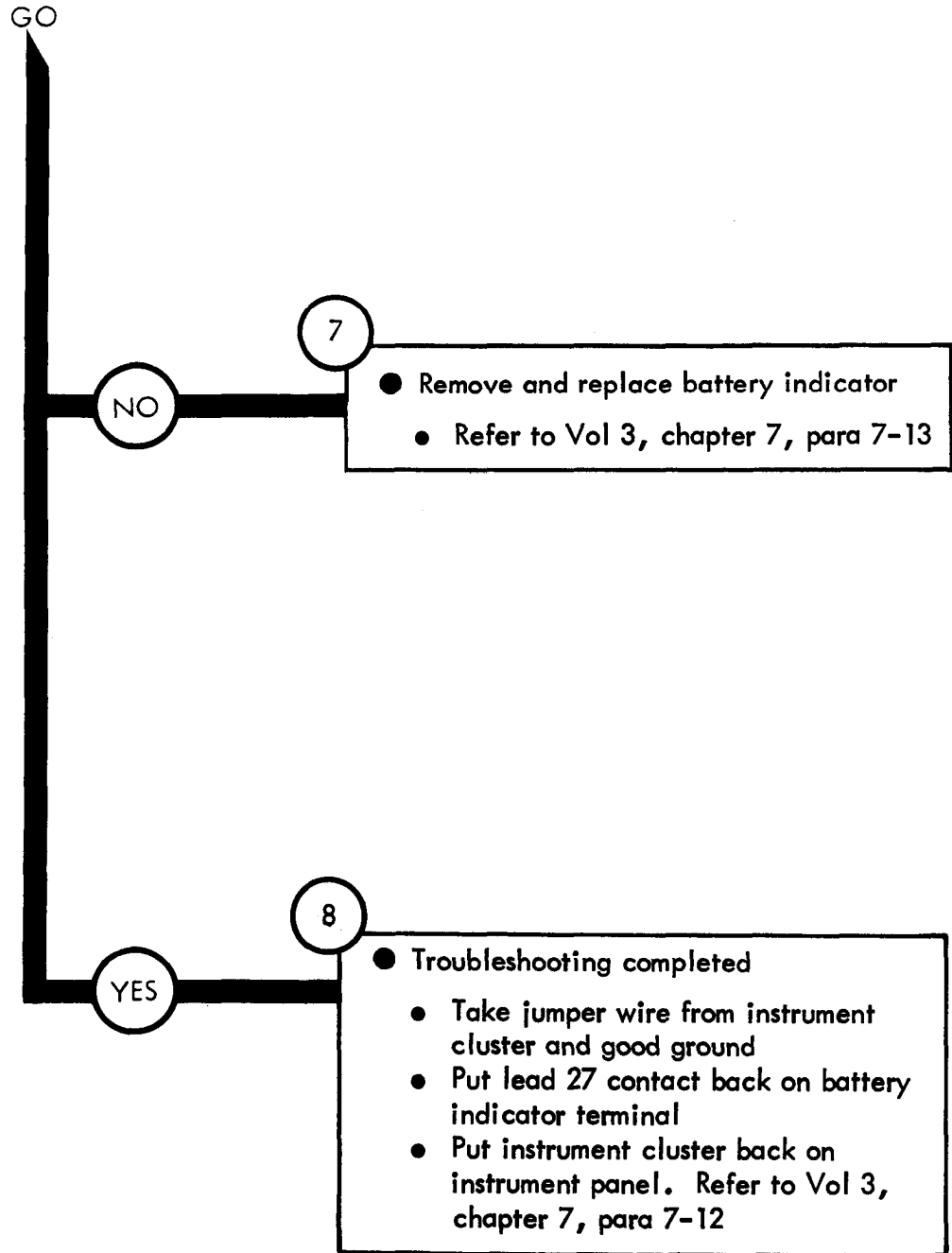

Figure 25-31 (Sheet 5 of 5)

Symptom

32

NO GAGES WORK

NOTE

The speedometer and tachometer cables and air pressure gage air hose must be removed to take off the instrument cluster from the instrument panel. A jumper wire must be placed from the instrument panel to a good ground for the gages to work

When checking voltage +24 volts DC means a range of +23 to +26 volts DC

1

- Park truck
- Refer to TM 9-2320-209-10

GO

Figure 25-32 (Sheet 1 of 5)

GO

2

- Check for voltage from batteries to instrument
 - Set ACCESSORY switch to OFF
 - Take off instrument cluster from instrument panel. Refer to Vol 3, chapter 7, para 7-12
 - Put jumper wire between instrument cluster and a good ground
 - Take off lead 27 at instrument harness assembly
 - Set ACCESSORY switch to ON

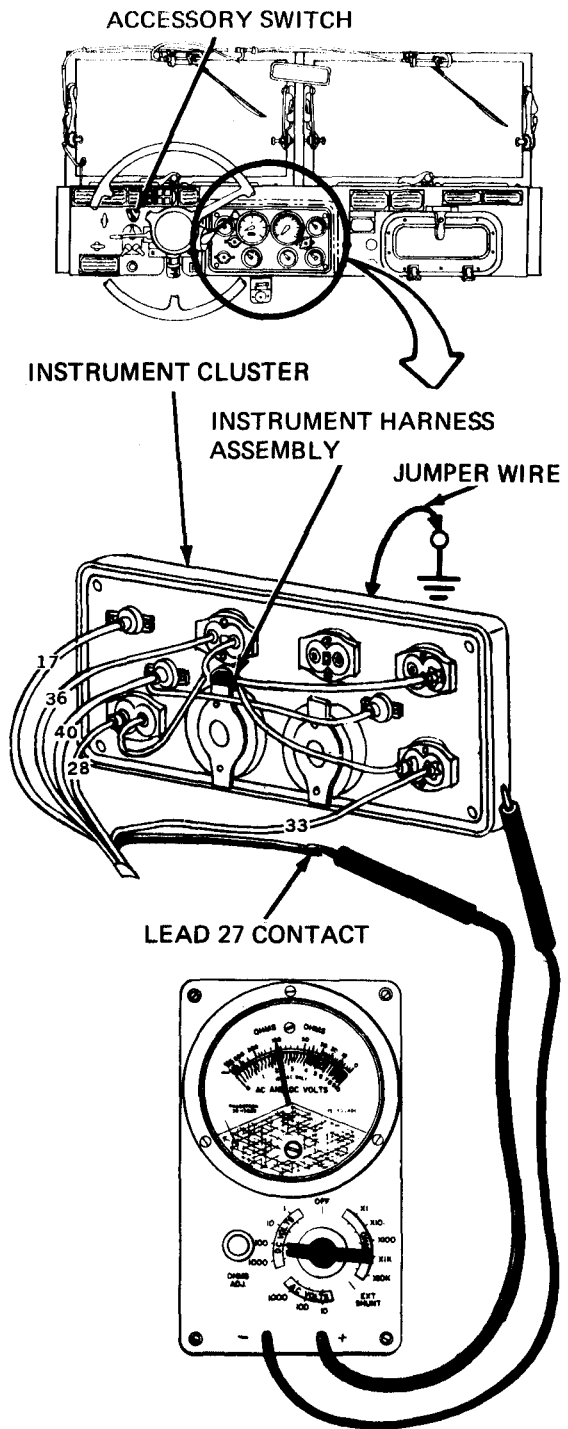

- Set multimeter to measure +24 volts DC. Refer to test equipment procedures index
- Put multimeter - lead on a good ground
- Put multimeter + lead on lead 27
- Read multimeter. Multimeter should measure +24 volts DC

Does multimeter measure less than +24 volts DC?

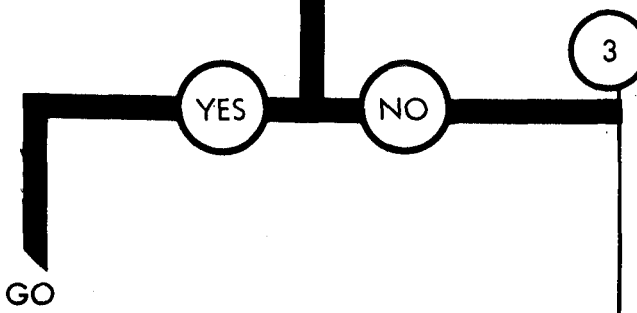

3

- Repair or replace instrument harness assembly
 - Set ACCESSORY switch to OFF
 - Repair or replace instrument harness assembly. Tell direct support maintenance

Figure 25 - 32 (Sheet 1 of 5)

GO

4

- Check for +24 volts through ACCESSORY switch
 - Set ACCESSORY switch to OFF
 - Take off ACCESSORY switch from instrument panel. Refer to Vol 3, chapter 7, para 7-15
 - Pull off lead 27 contact from ACCESSORY switch
 - Put ACCESSORY switch lever back on ACCESSORY switch. Refer to Vol 3, chapter 7, para 7-15
 - Set ACCESSORY switch to ON

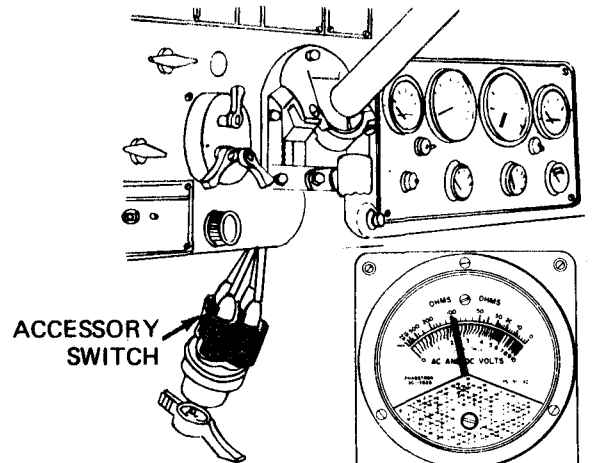

- Put multimeter - lead on a good ground
- Put multimeter + lead on ACCESSORY switch connector for lead 27 contact
- Read multimeter. Multimeter should measure +24 volts DC

Does multimeter measure less than +24 volts DC?

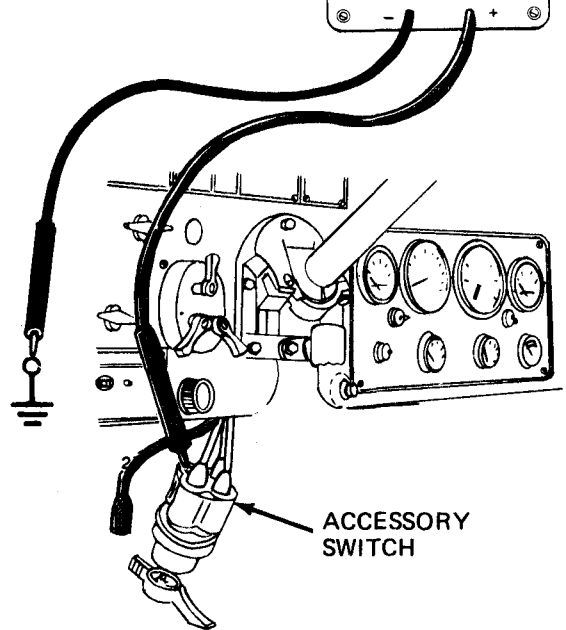

YES

NO

5

GO

- Repair or replace front harness
 - Take off jumper wire from instrument cluster
 - Put instrument cluster back on instrument panel. Refer to Vol 3, chapter 7, para 7-12
 - Set ACCESSORY switch to OFF.
 - Repair or replace front harness. Tell direct support maintenance

TA 114464

Figure 25-32 (Sheet 3 of 5)

GO

6

- Check for +24 volts DC to ACCESSORY switch
 - Set ACCESSORY switch to OFF
 - Put lead 27 contact back into ACCESSORY switch lead 27 connector
 - Pull out both lead 11 contacts from ACCESSORY switch lead 11 connectors

- Put multimeter - lead on a good ground
- Put multimeter + lead on one lead 11 contact. Read multimeter. Multimeter should measure +24 volts DC
- Put multimeter + lead on other lead 11 contact. Read multimeter. Multimeter should measure +24 volts DC

Does multimeter measure +24 volts DC for both tests?

GO

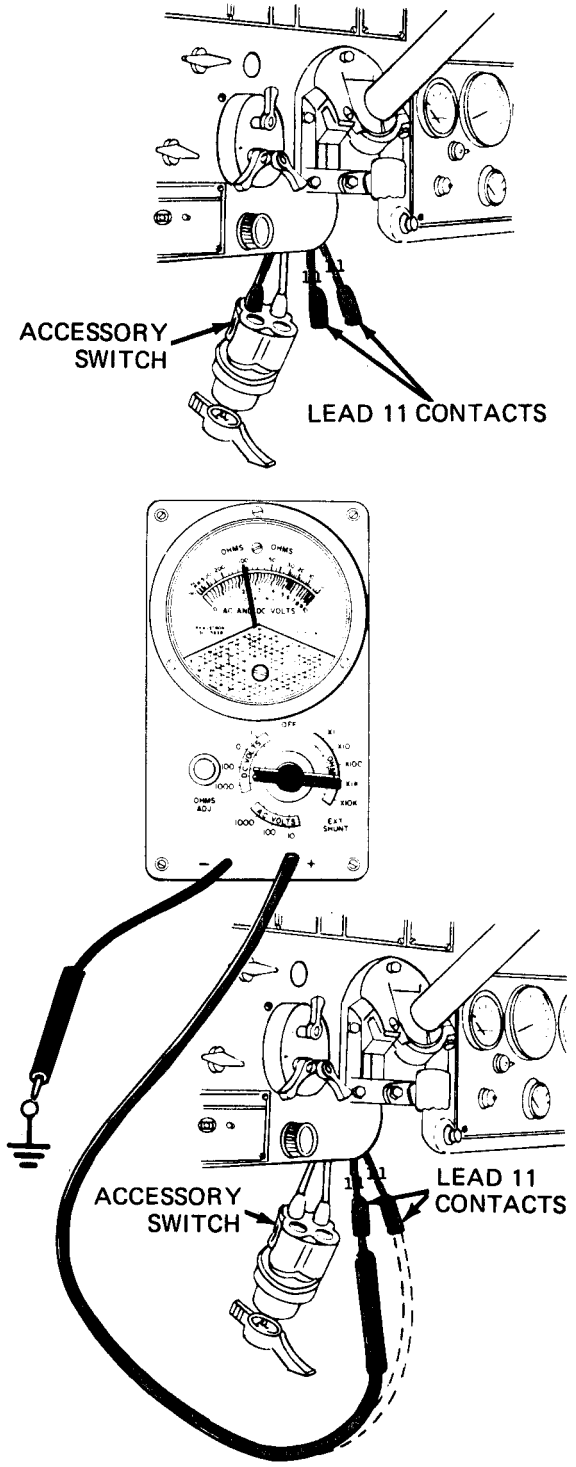

Figure 25-32 (Sheet 4 of 5)

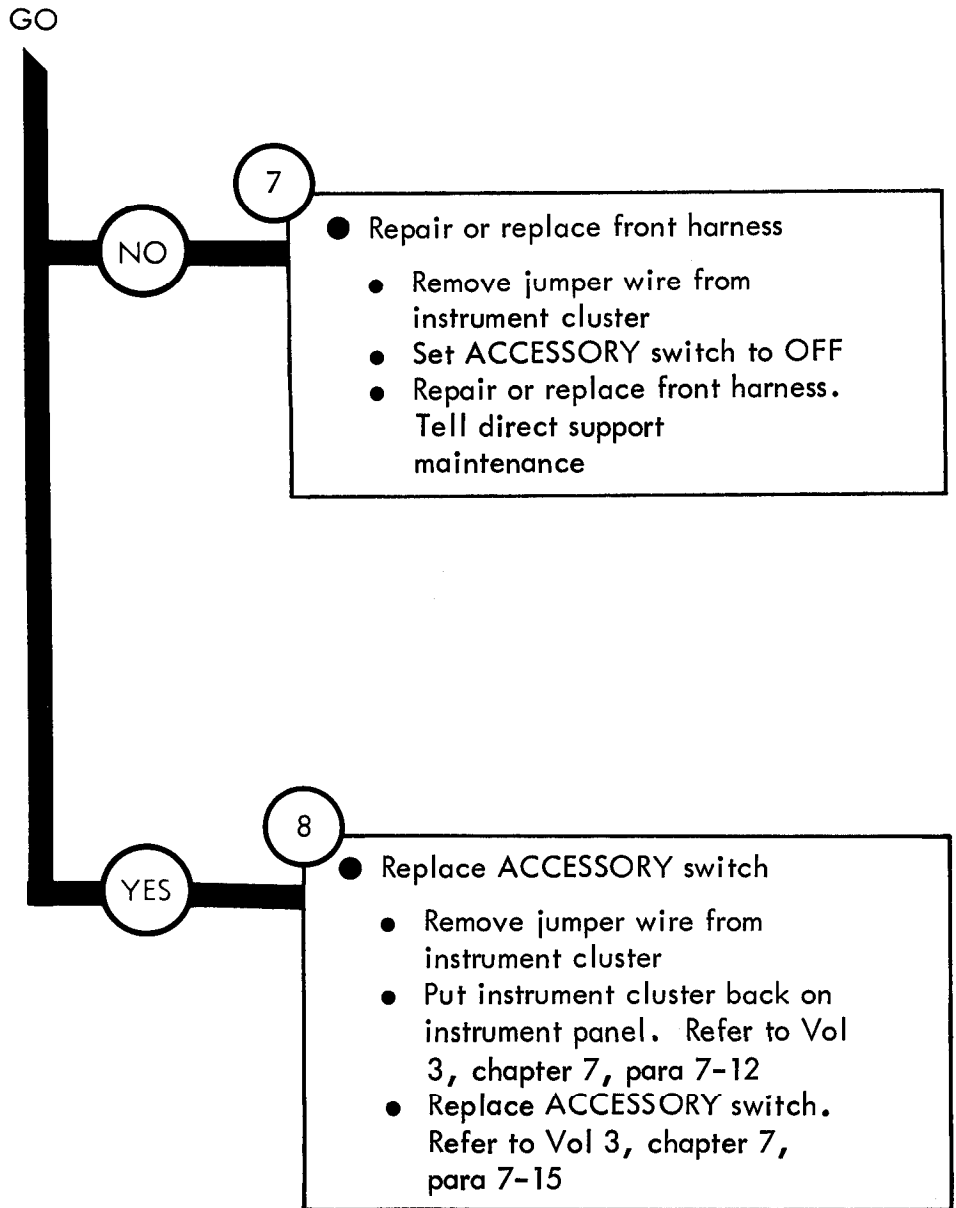

Figure 25-32 (Sheet 5 of 5)

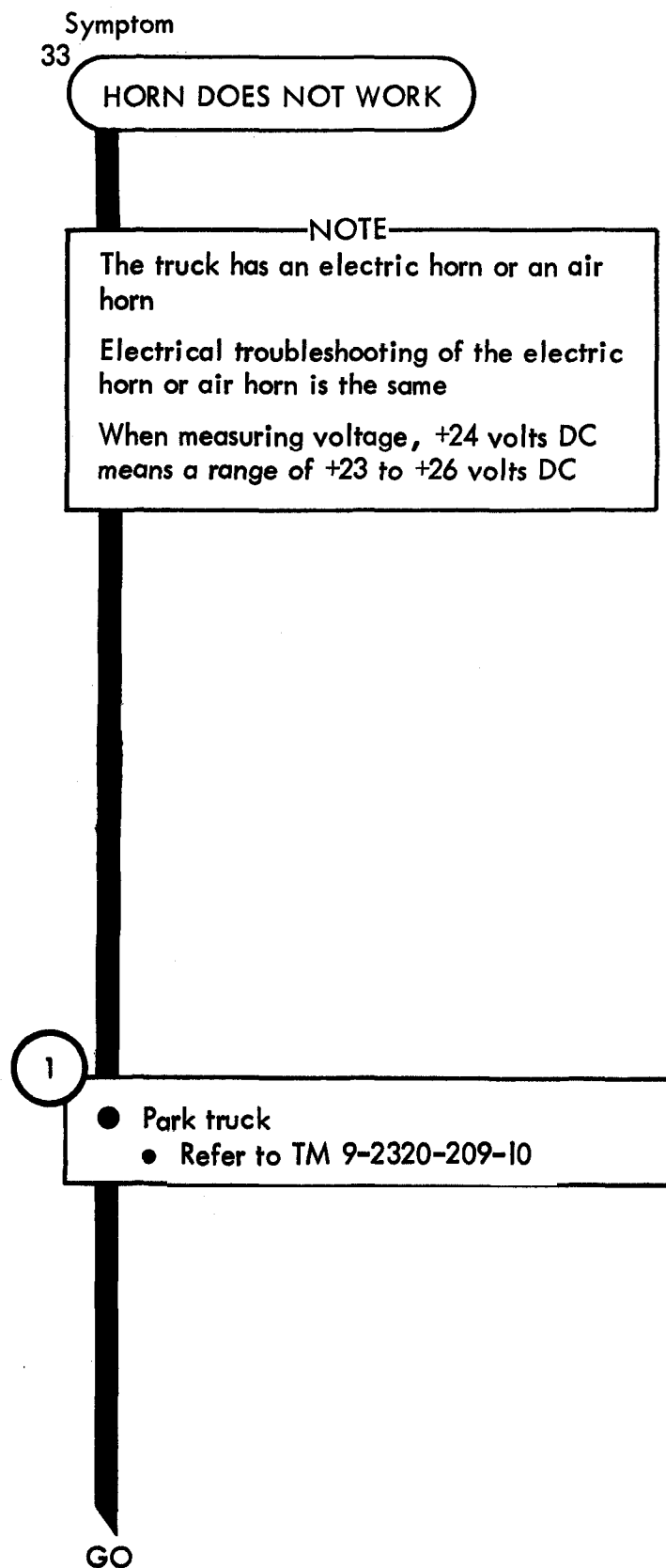

Figure 25-33 (Sheet 1 of 10)

2

- Check lead 25 from circuit breaker to horn for +24 volts DC
- Remove top lead 25 from horn terminal
- Set multimeter to measure +24 volts DC. Refer to test equipment procedures index
- Put multimeter - lead on a good ground
- Put multimeter + lead on lead 25 contact.
- Read multimeter. Multimeter should measure +24 volts DC

Does multimeter measure +24 volts DC?

GO

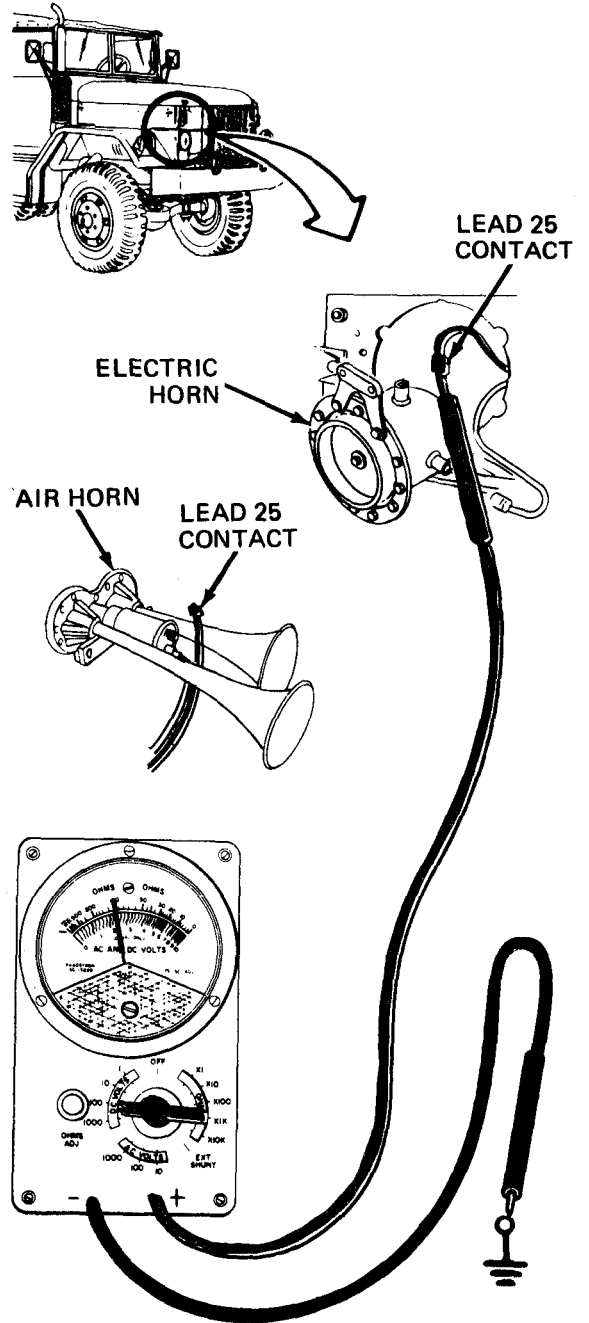

TA 114468

Figure 25-33 (Sheet 2 of 10)

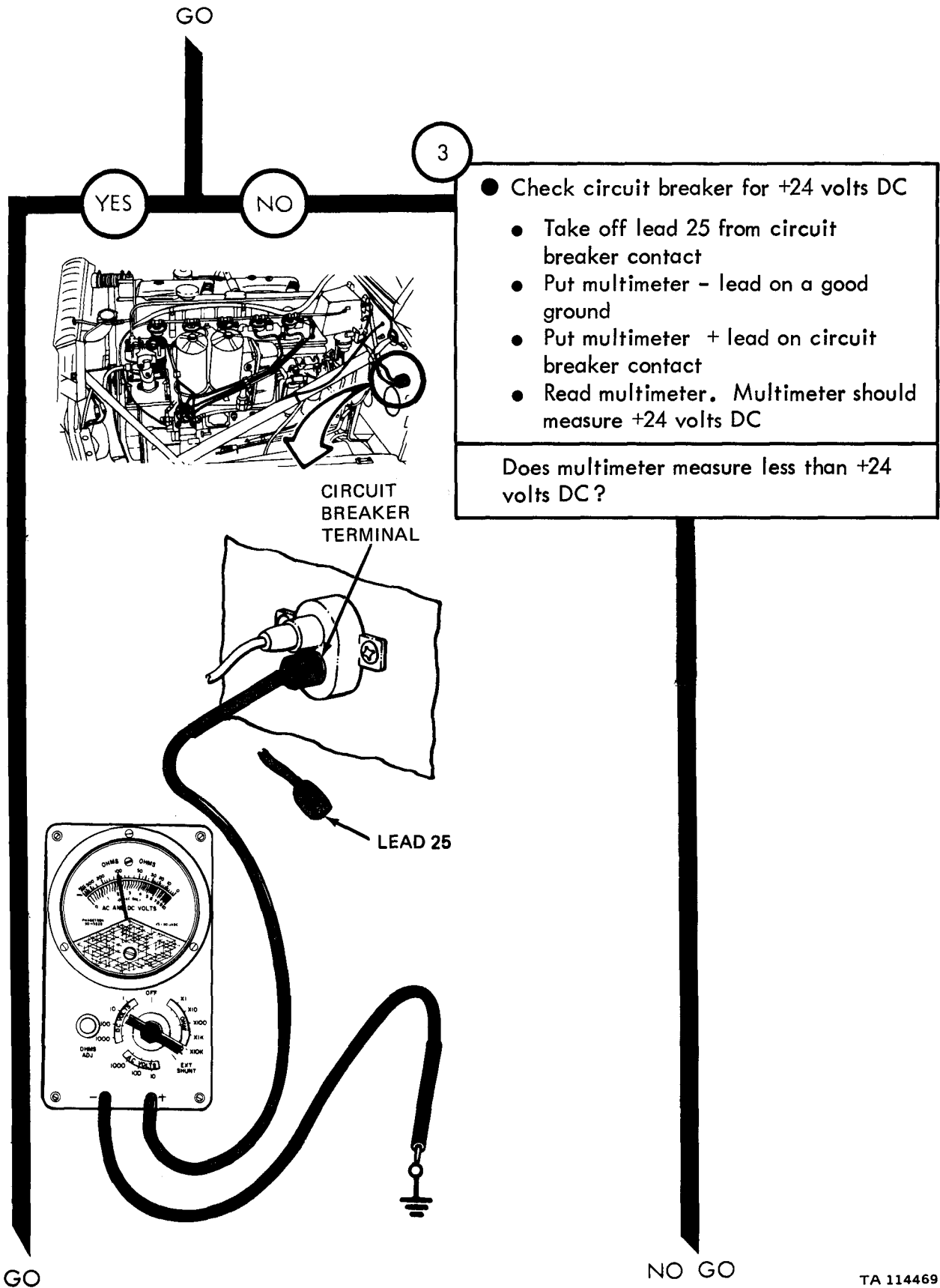

Figure 25-33 (Sheet 3 of 10)

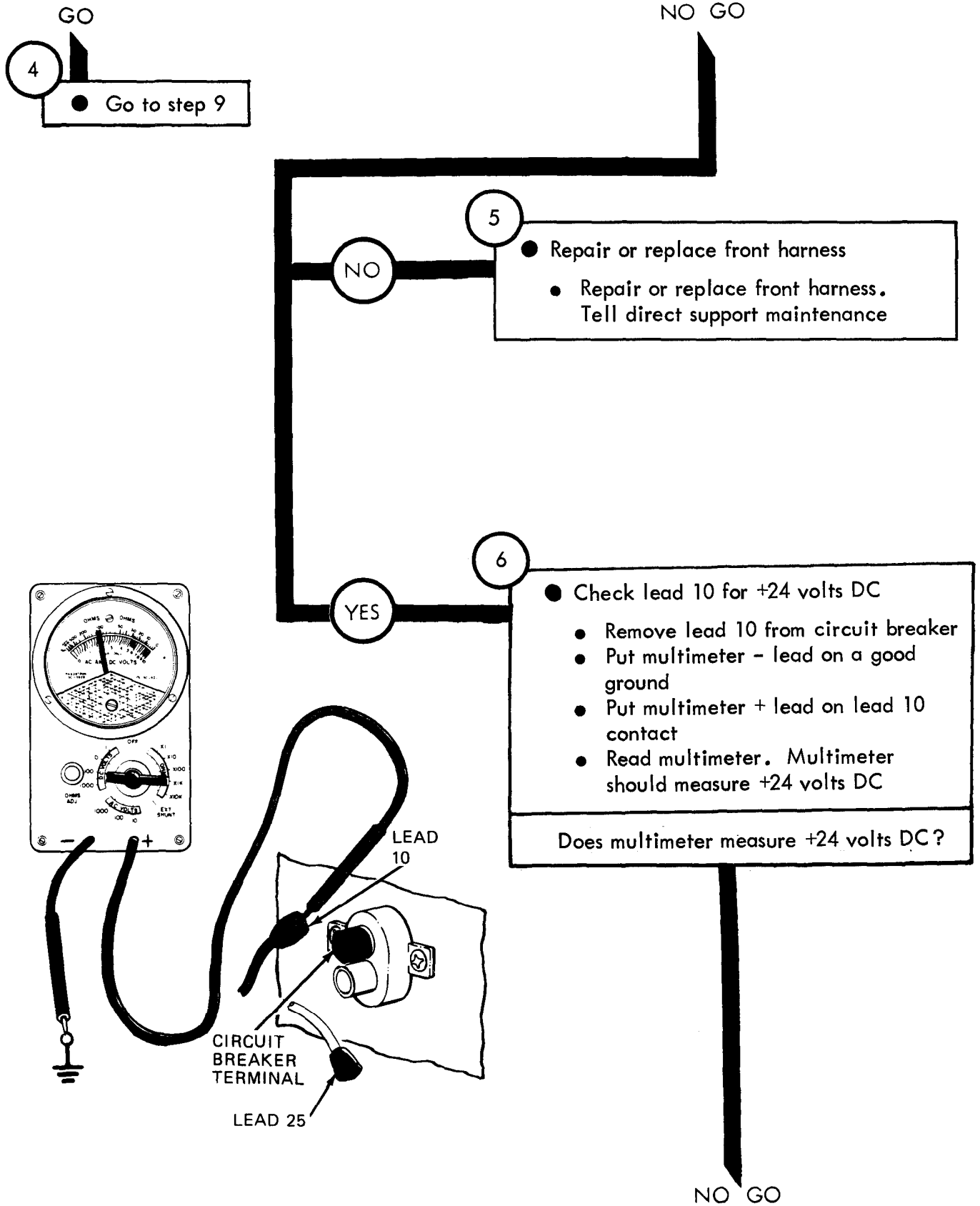

Figure 25-33 (Sheet 4 of 10)

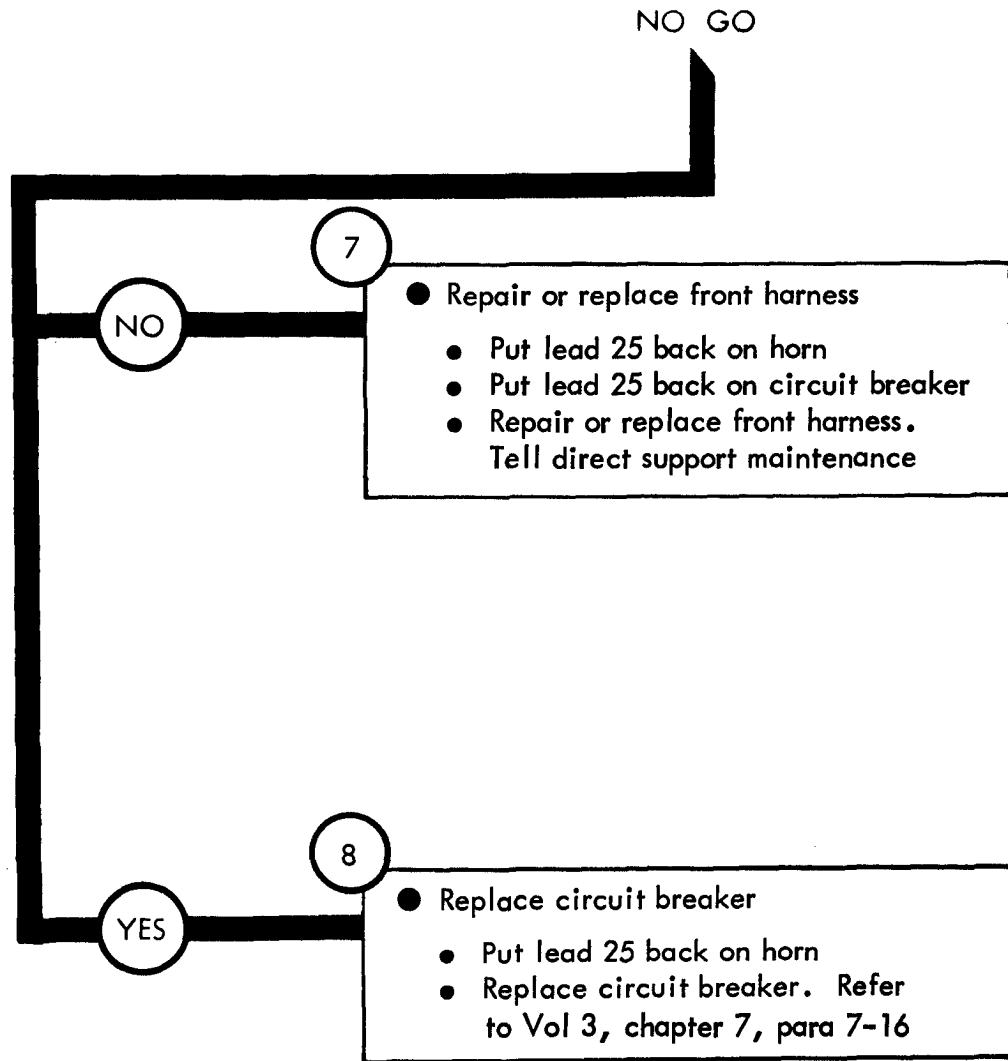

Figure 25-33 (Sheet 5 of 10)

From step 4

9

- Check horn for +24 volts DC
 - Put lead 25 back on horn terminal
 - Take off lead 25 from bottom horn terminal
 - Put multimeter - lead on a good ground
 - Put multimeter + lead on horn terminal
 - Read multimeter. Multimeter should measure +24 volts DC

Does multimeter measure +24 volts DC?

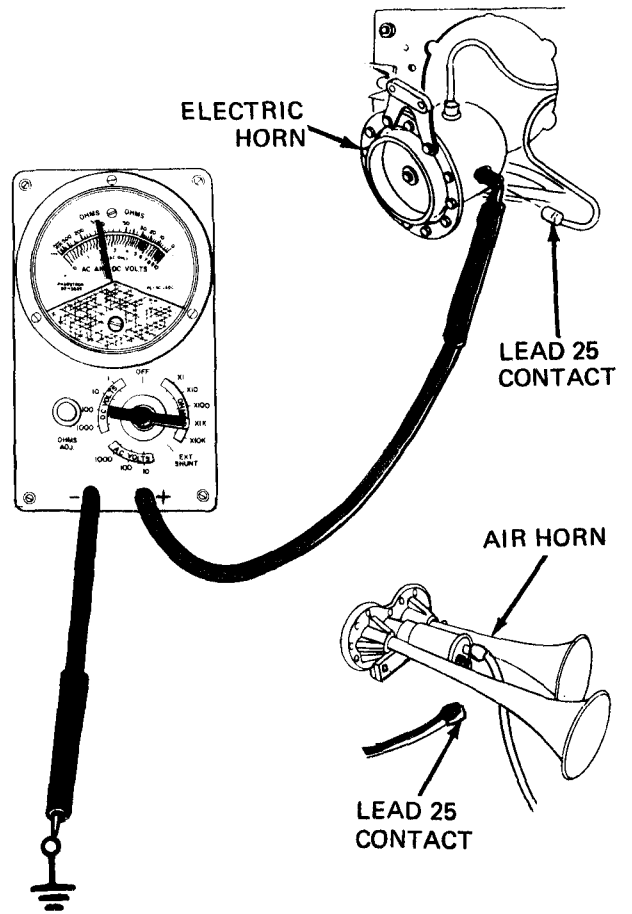

NO

YES

10

- If horn is electric horn replace horn
 - Replace horn. Refer to Vol 3, chapter 7, para 7-54
- If horn is air horn replace air horn solenoid
 - Replace air horn solenoid
 - Refer to Vol 3, chapter 7, para 7-53

GO

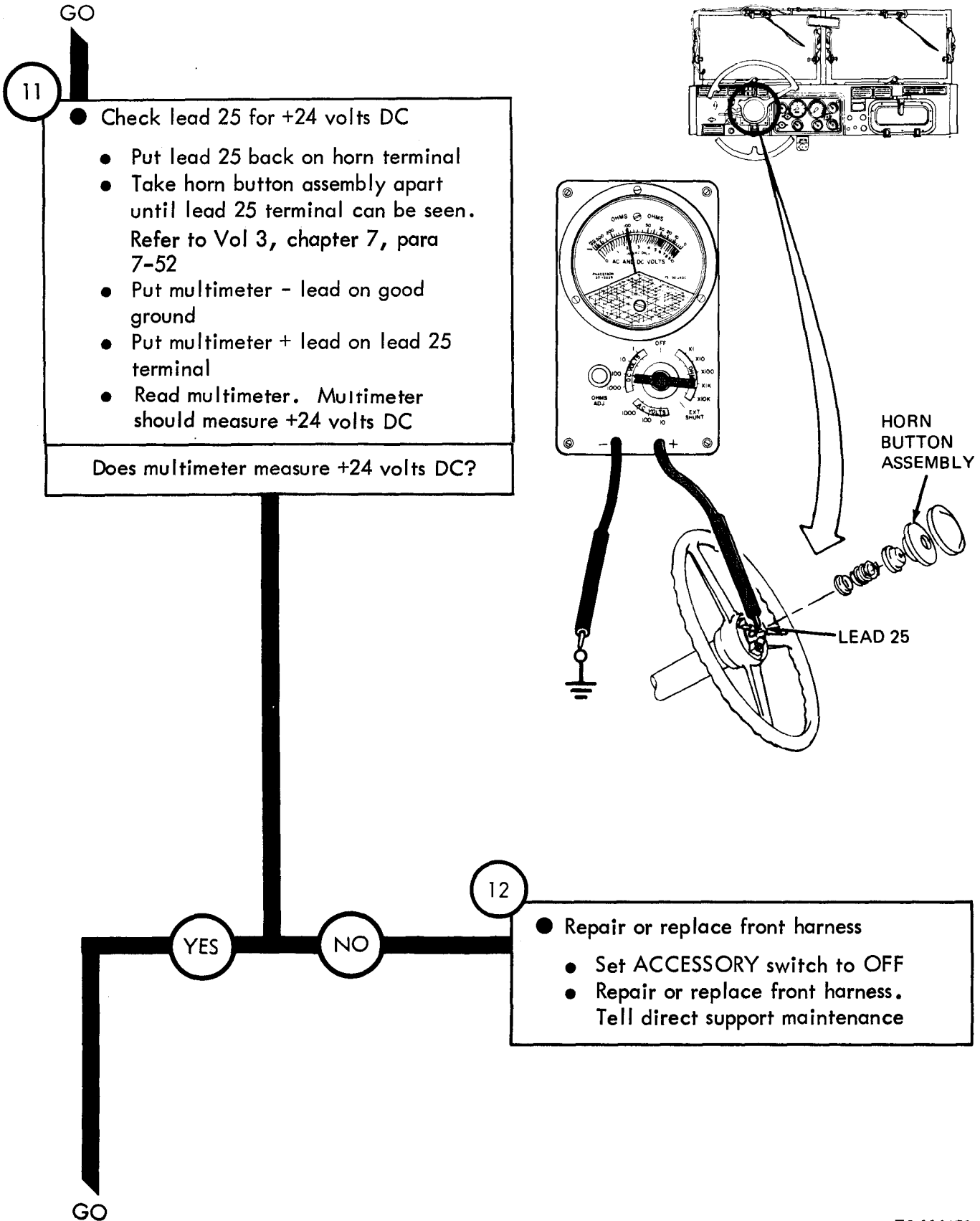

11

- Check lead 25 for +24 volts DC
 - Put lead 25 back on horn terminal
 - Take horn button assembly apart until lead 25 terminal can be seen. Refer to Vol 3, chapter 7, para 7-52
 - Put multimeter - lead on good ground
 - Put multimeter + lead on lead 25 terminal
 - Read multimeter. Multimeter should measure +24 volts DC

Does multimeter measure +24 volts DC?

YES

NO

12

- Repair or replace front harness
 - Set ACCESSORY switch to OFF
 - Repair or replace front harness. Tell direct support maintenance

Figure 25-33 (Sheet 7 of 10)

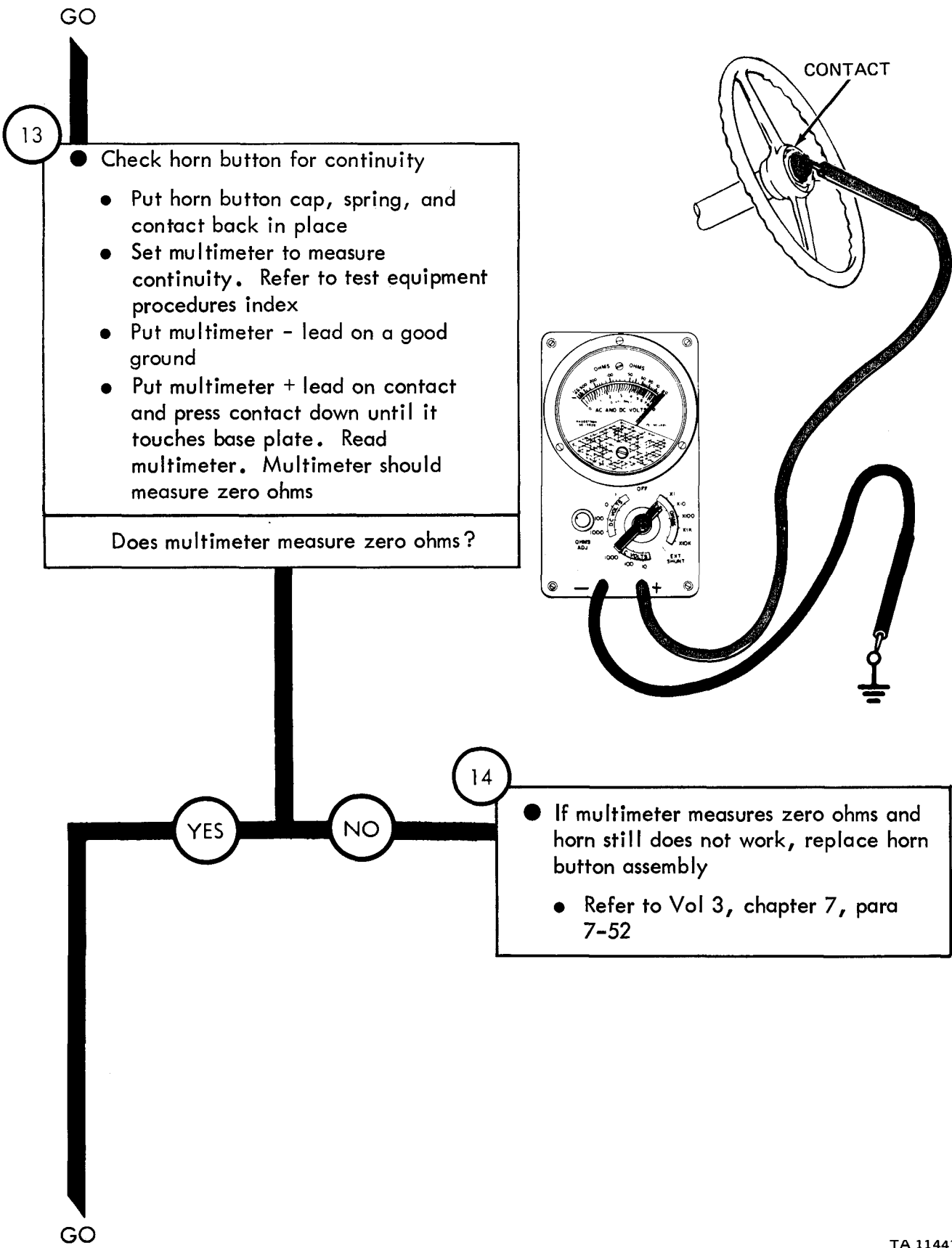
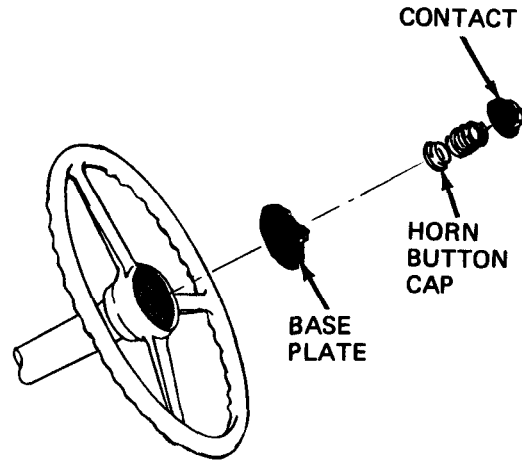

Figure 25-33 (Sheet 8 of 10)

GO

15

- Clean horn button contacts
 - Take off horn button cap, spring, and contact
 - Take off base plate from steering column. Refer to Vol 3, chapter 7, para 7-52
 - Clean steering column where base plate makes contact. Clean both sides of base plate
 - Clean contact and cap



- Put base plate, horn button cap, spring, and contact back in place. Refer to Vol 3, chapter 7, para 7-52
- Put multimeter - lead on a good ground
- Put multimeter + lead on contact and press contact down until it touches base plate
- Read multimeter. Multimeter should measure zero ohms

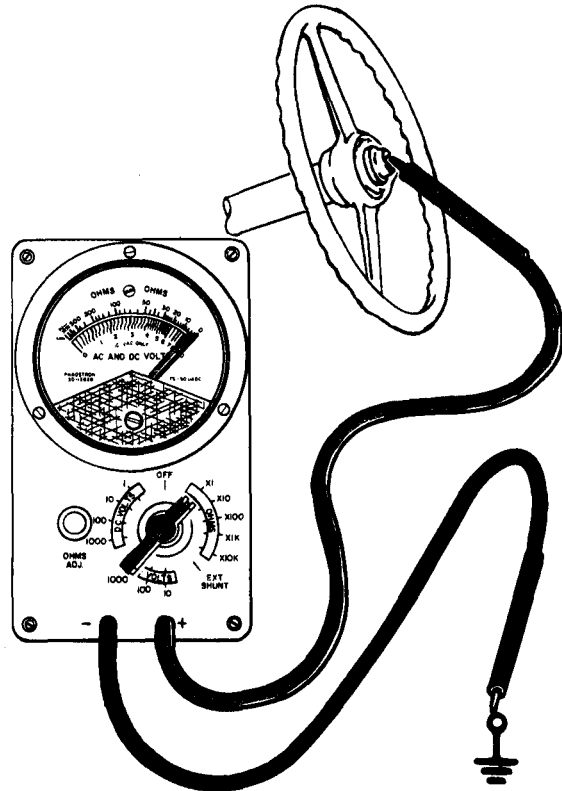

Does multimeter measure zero ohms?

GO

TA 114475

Figure 25-33 (Sheet 9 of 10)

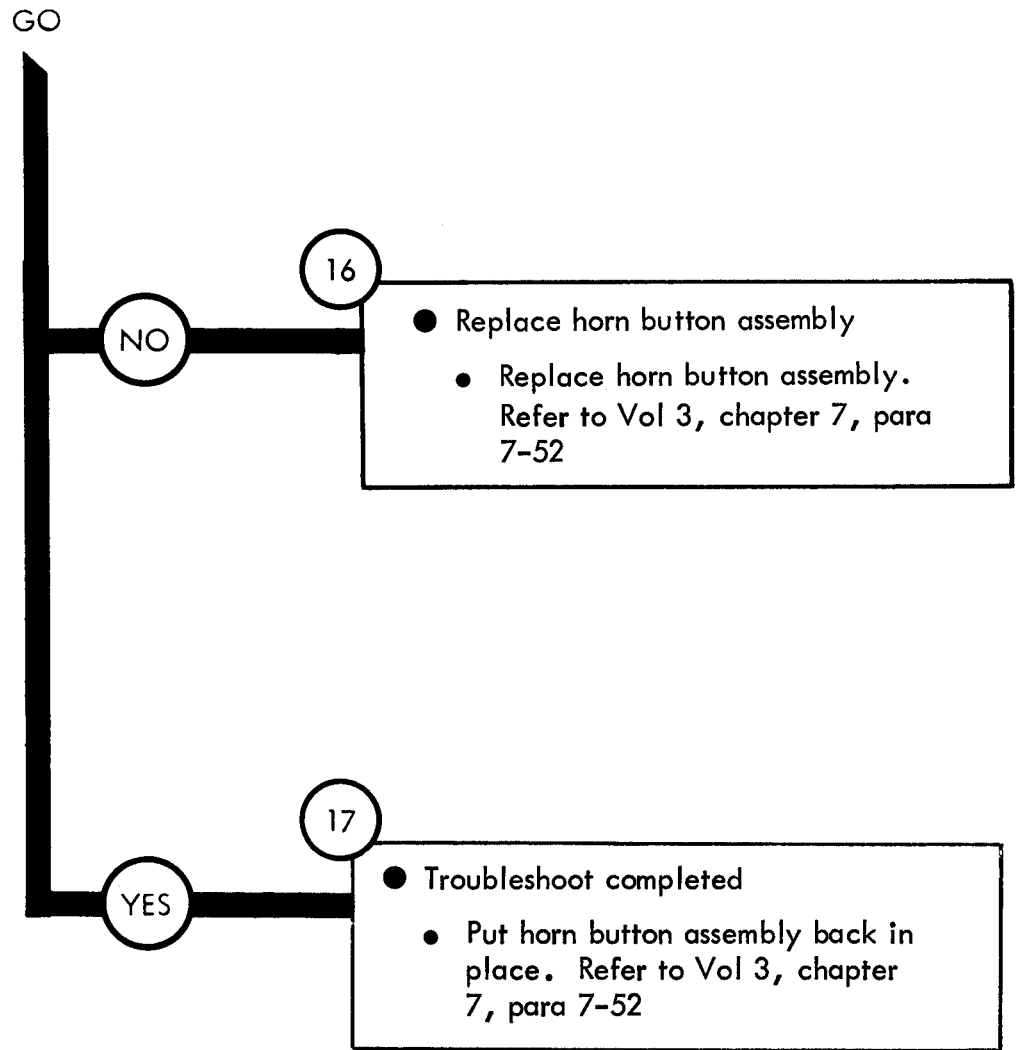

Symptom

34 LOW AIR WARNING BUZZER DOES NOT WORK

NOTE

When measuring voltage +24 volts DC means a range of +23 to +26 volts DC

1

- Park truck
- Refer to TM 9-2320-209-10

2

- Check for +24 volts DC, at input to low air warning buzzer
 - Set ACCESSORY switch to OFF
 - Take off lead 85 from buzzer
 - Turn air reservoir drain cocks to left and drain reservoirs to less than 60 psi
 - Set ACCESSORY switch to ON

- Set multimeter to measure +24 volts DC. Refer to test equipment procedures index
- Put - lead on a good ground
- Put + lead on lead 85 contact
- Read multimeter. Multimeter should measure +24 volts DC

Does multimeter measure less than +24 volts DC?

GO

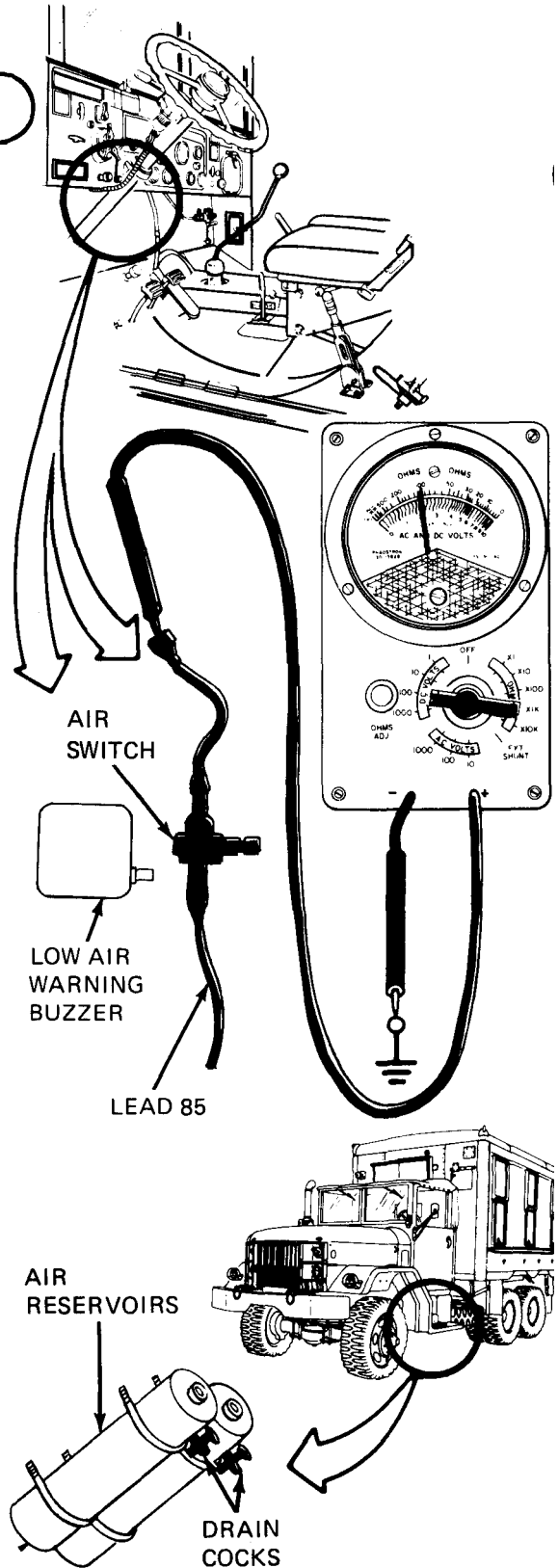

TA 114477

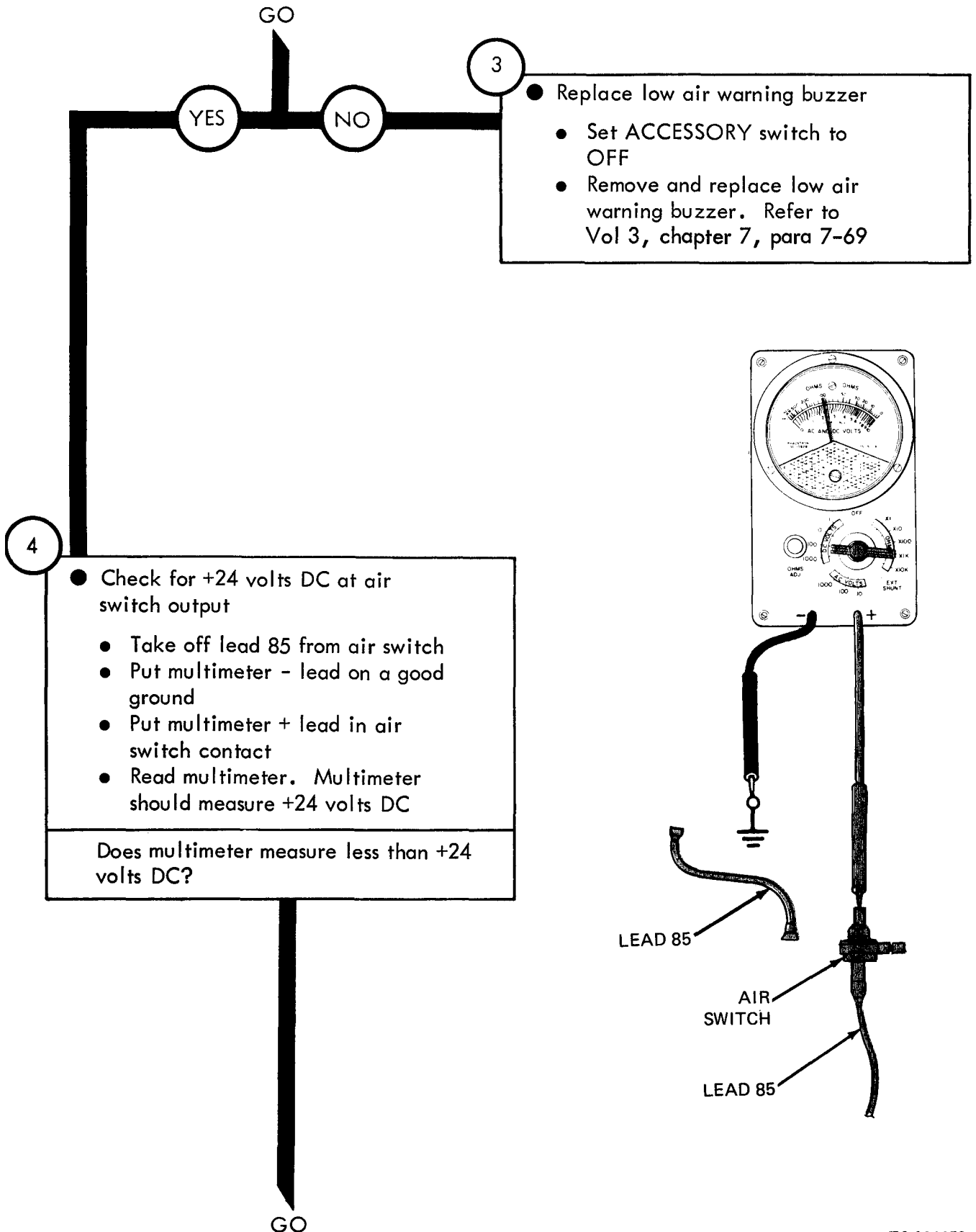
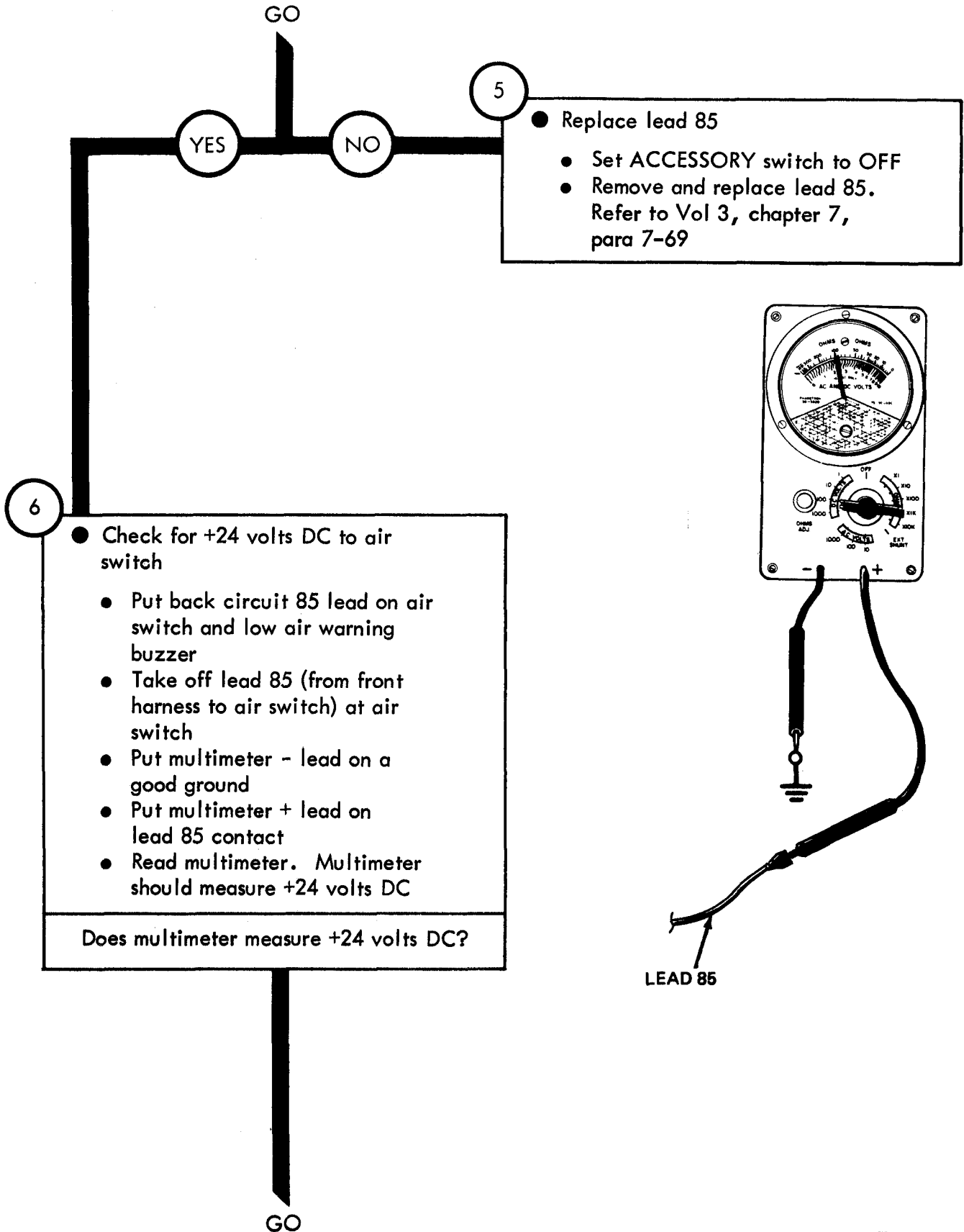
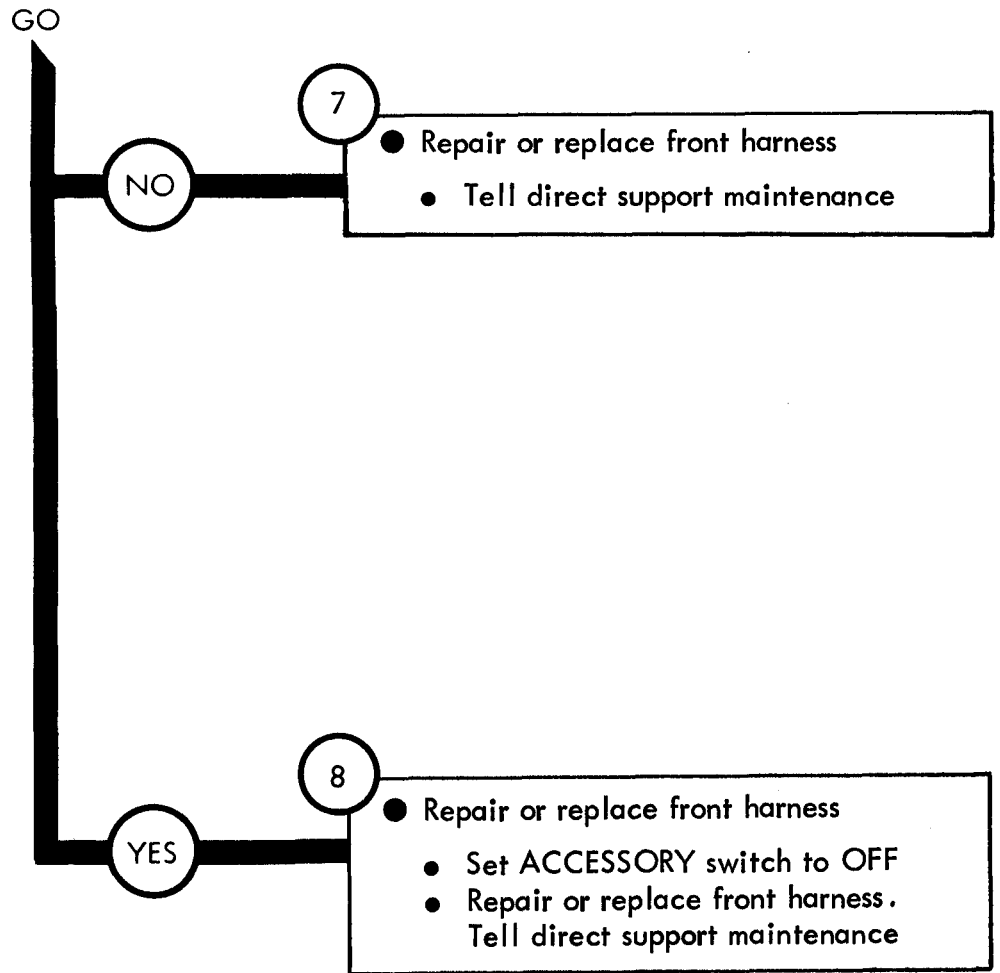

Figure 25-34 (Sheet 2 of 4)



TA 114479



TA 114480

Figure 25-34 (Sheet 4 of 4)

Symptom

35 FUEL PUMP DOES NOT WORK

NOTE

When measuring voltage +24 volts DC means a range of +23 to +26 volts DC

1

- Park truck
- Refer to TM 9-2320-209-10

2

- Check that +24 volts DC is getting to fuel pump
 - Pull off 654 plug from fuel pump fuse holder.
 - Set ACCESSORY switch to ON
 - Set multimeter to measure +24 volts DC. Refer to test equipment procedures index
 - Put multimeter - lead on a good ground
 - Put multimeter + lead on circuit 654 contact in plug. Read multimeter. Multimeter should measure +24 volts DC

Does multimeter measure +24 volts DC?

GO

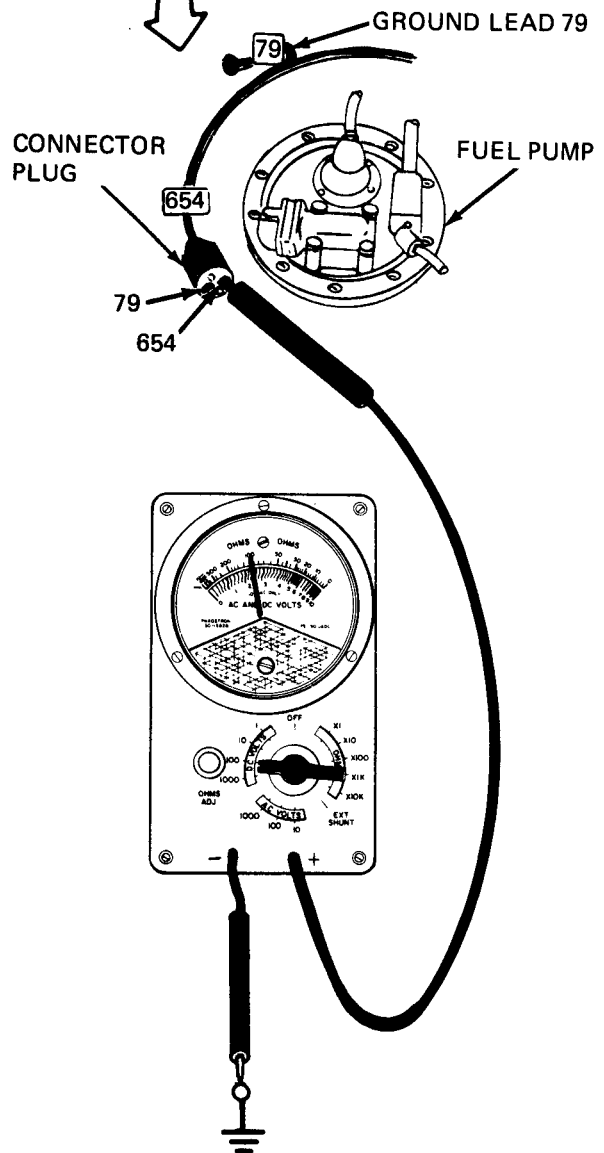
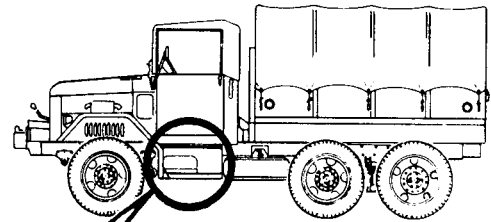

TA 114481

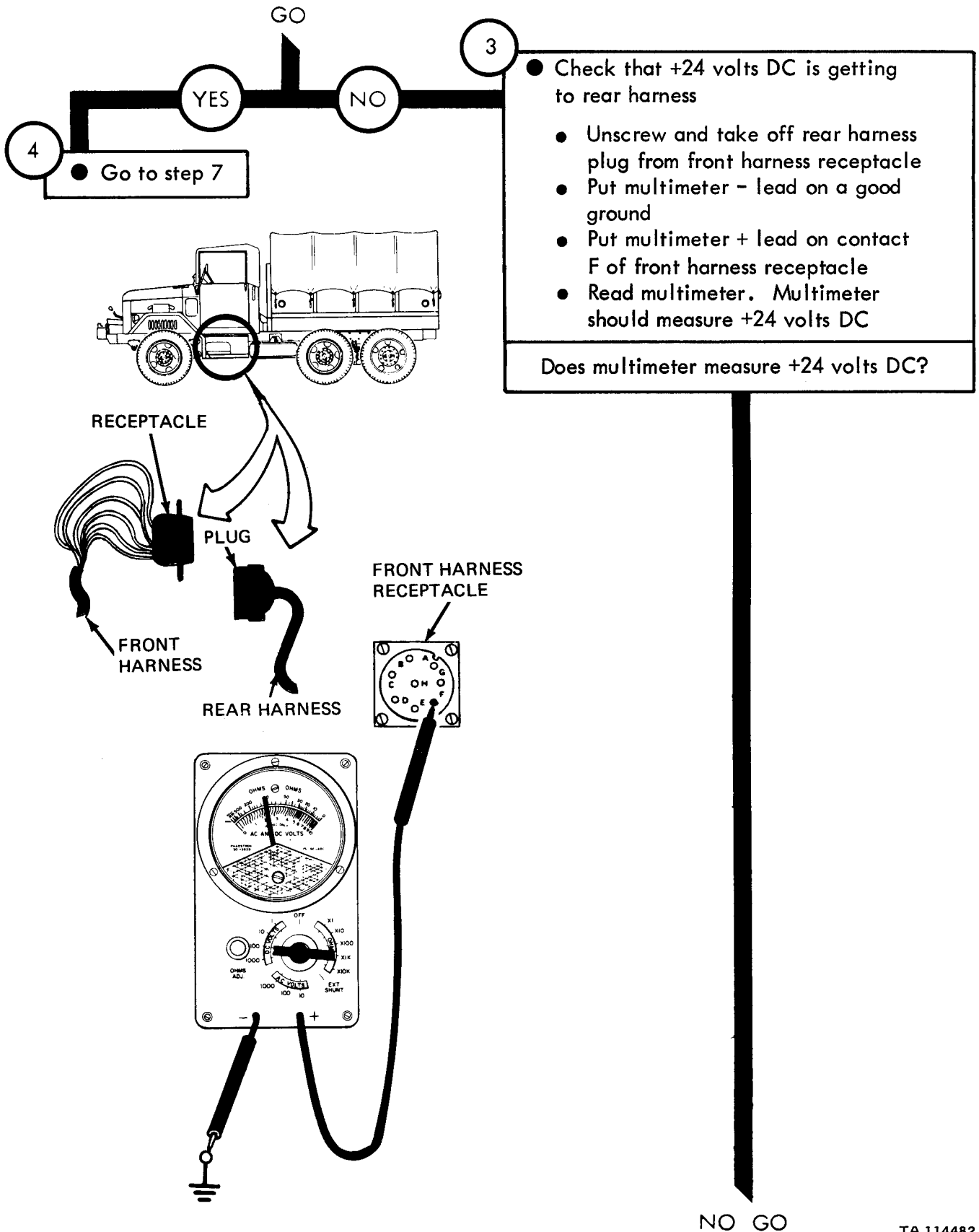
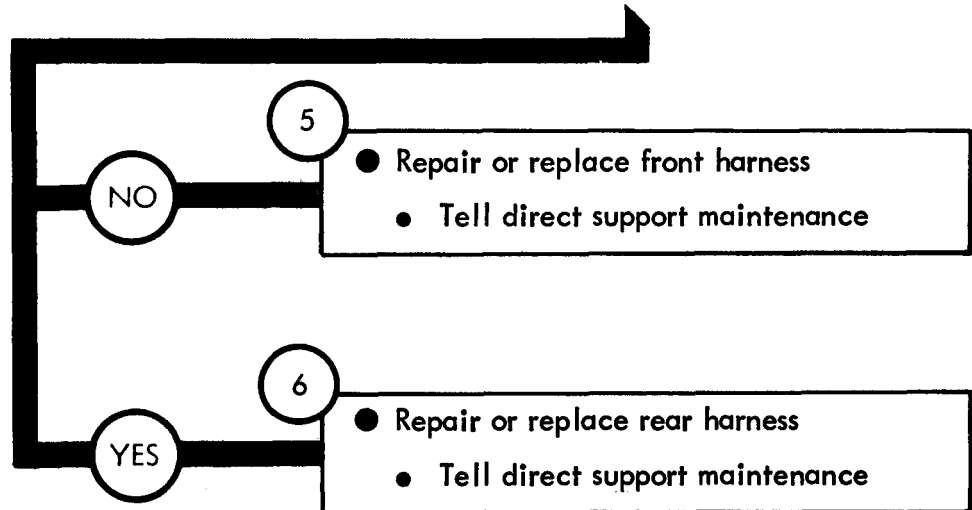

Figure 25-35 (Sheet 2 of 5)

From step 4

NO GO



7

- Check continuity through fuel pump connector harness ground
 - Set ACCESSORY switch to OFF
 - Set multimeter to check continuity. Refer to test equipment procedures index
 - Put multimeter - lead on a good ground
 - Put multimeter + lead on lead 79 contact in plug
 - Read multimeter. Multimeter should measure zero ohms

Does multimeter measure zero ohms?

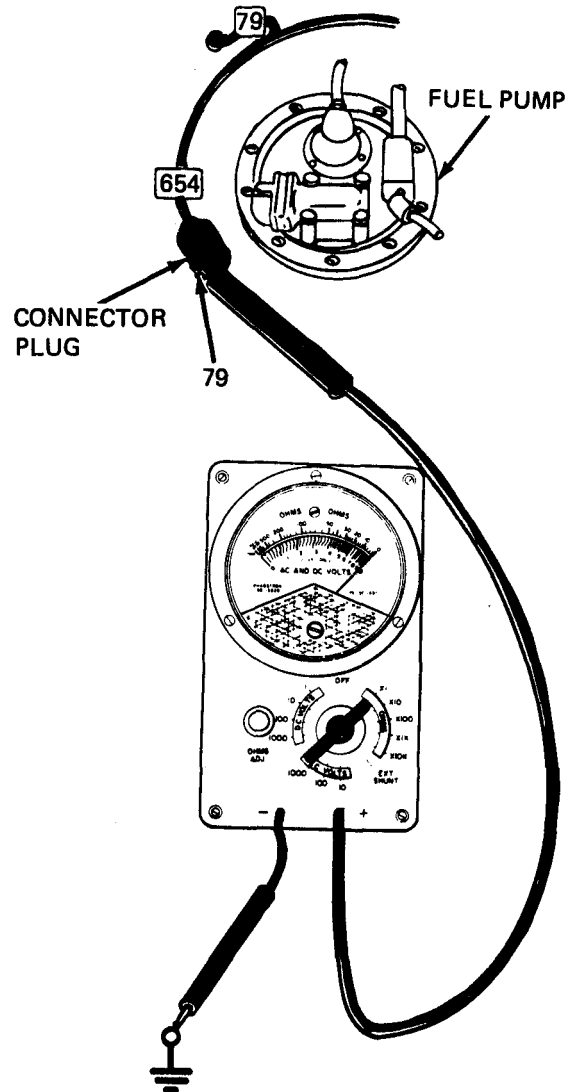

GO

TA 114483

Figure 25-35 (Sheet 3 of 5)

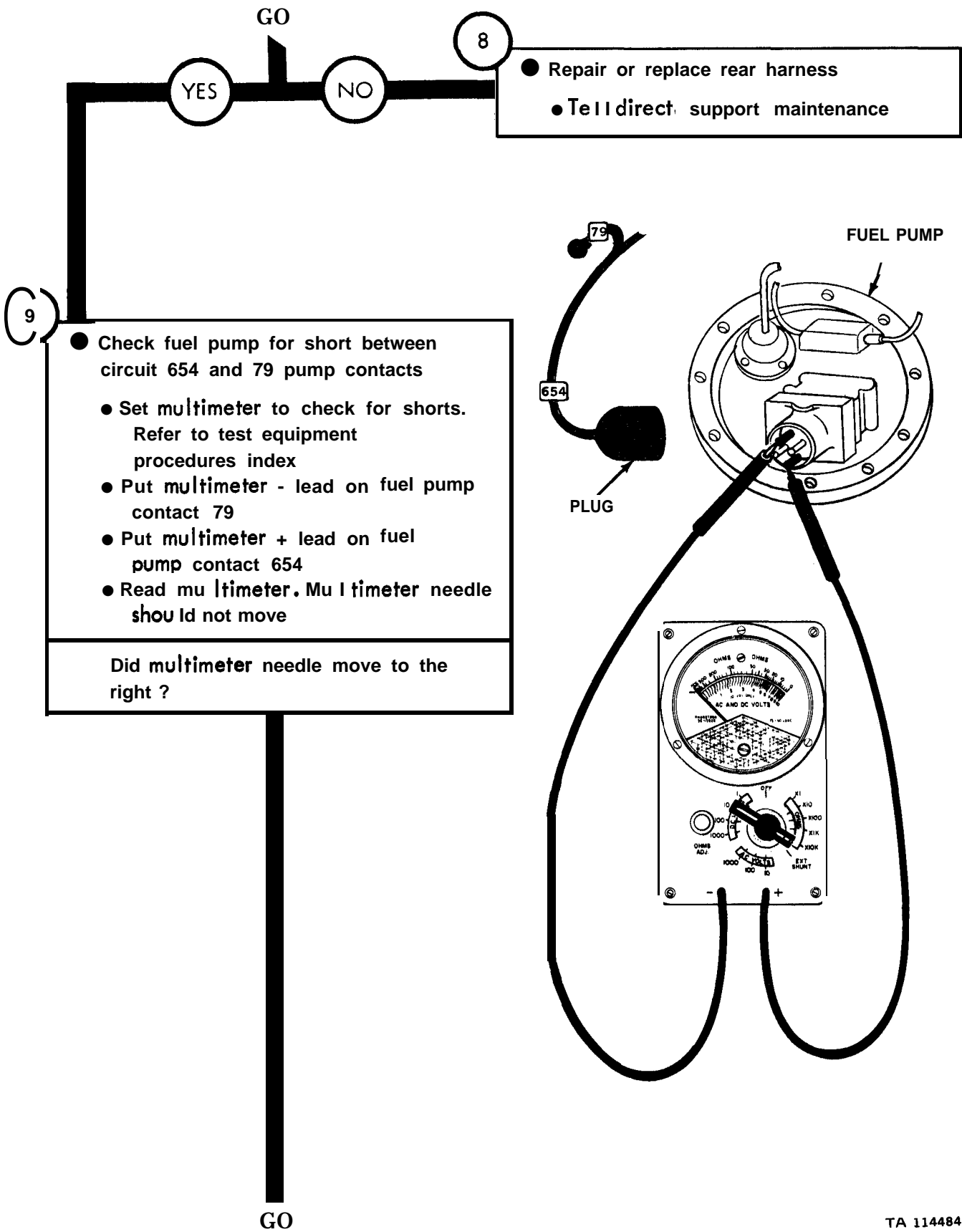

8

- Repair or replace rear harness
- Tell direct support maintenance

9

- Check fuel pump for short between circuit 654 and 79 pump contacts
- Set multimeter to check for shorts. Refer to test equipment procedures index
- Put multimeter - lead on fuel pump contact 79
- Put multimeter + lead on fuel pump contact 654
- Read multimeter. Multimeter needle should not move

Did multimeter needle move to the right?

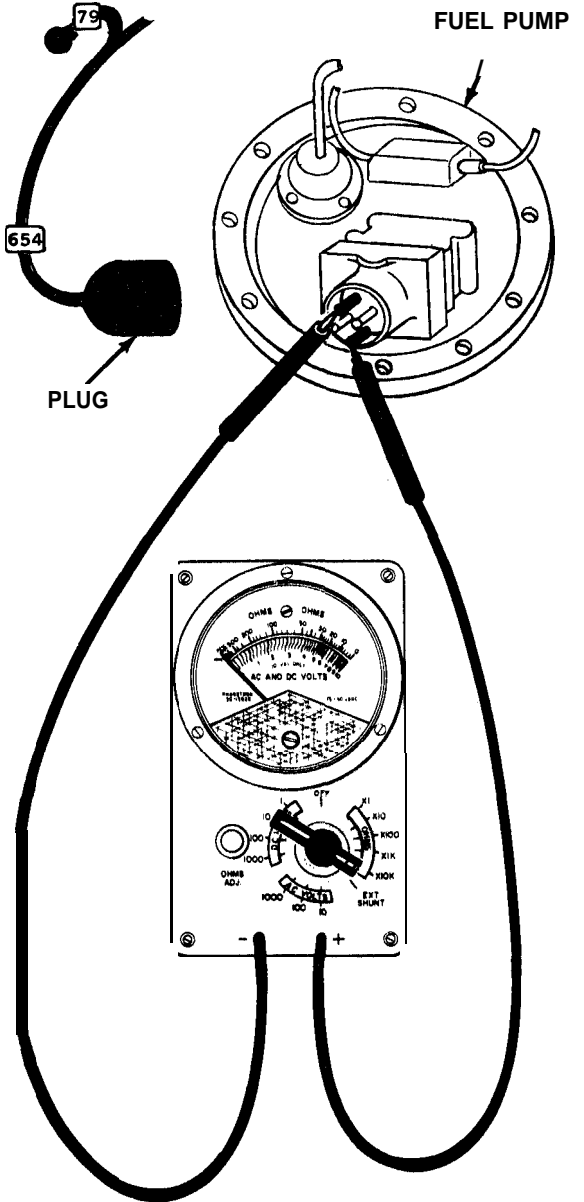

GO

TA 114484

Figure 25-35 (Sheet 4 of 5)

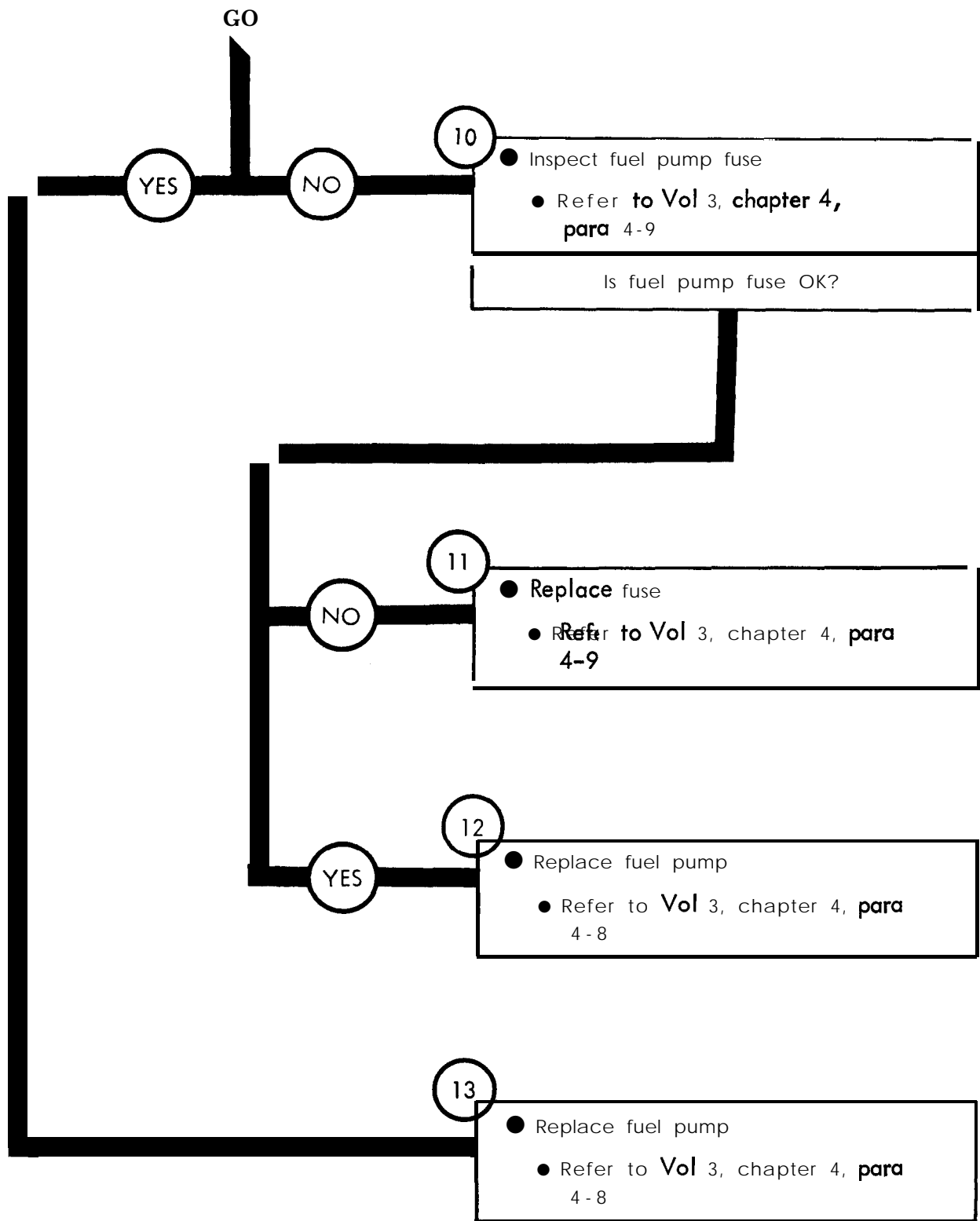

TA 114485

Figure 25-35 (Sheet 5 of 5)

Symptom
36

ENGINE MANIFOLD HEATER DOES NOT WORK

NOTE
When measuring voltage +24 volts DC means a range of +23 to +26 volts DC

- 1
- Park truck
 - Refer to TM 9-2320-209-10

- 2
- Check engine manifold heater ignition circuit for +24 volts DC
 - Take off lead 55 at manifold heater ignition unit
 - Set MANIFOLD HEATER switch to ON
 - Set ACCESSORY switch to ON

- Set multimeter to measure +24 volts DC. Refer to test equipment procedures index
- Put multimeter - lead on a good ground
- Put multimeter + lead on lead 55 contact
- Read multimeter. Multimeter should measure less than +24 volts DC

Does multimeter measure less than +24 volts DC?

GO

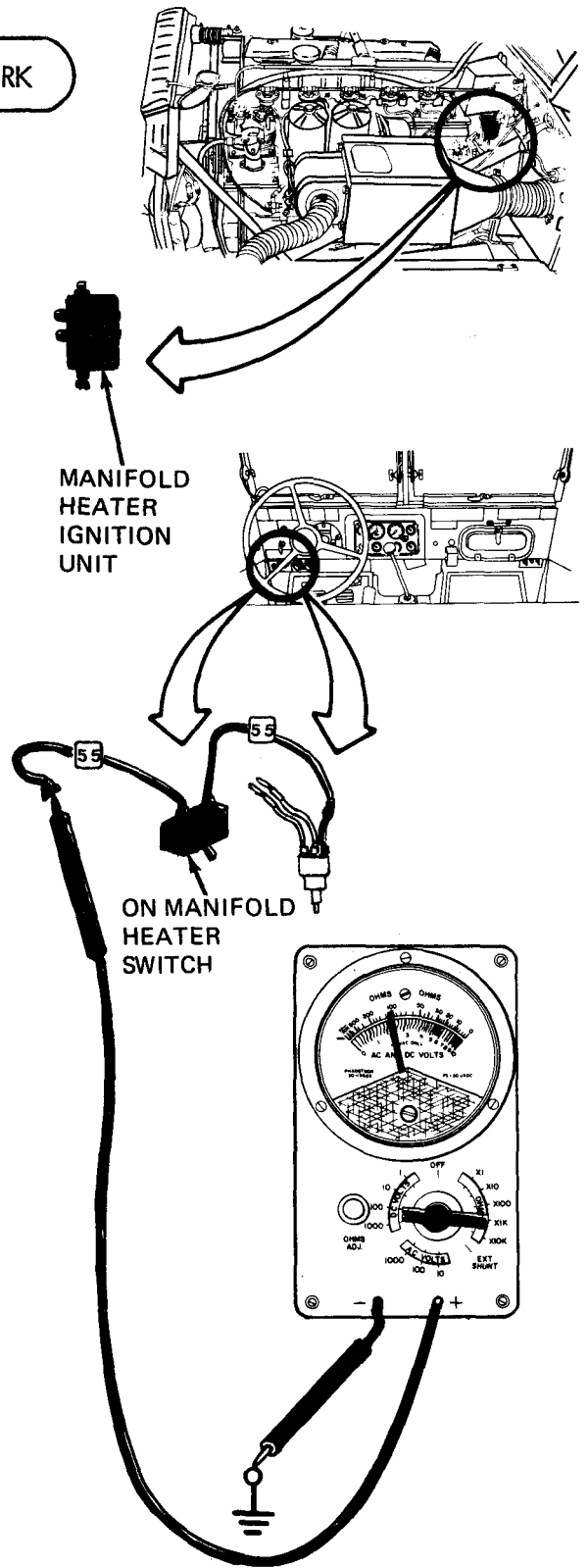

TA 114486

Figure 25-36 (Sheet 1 of 5)

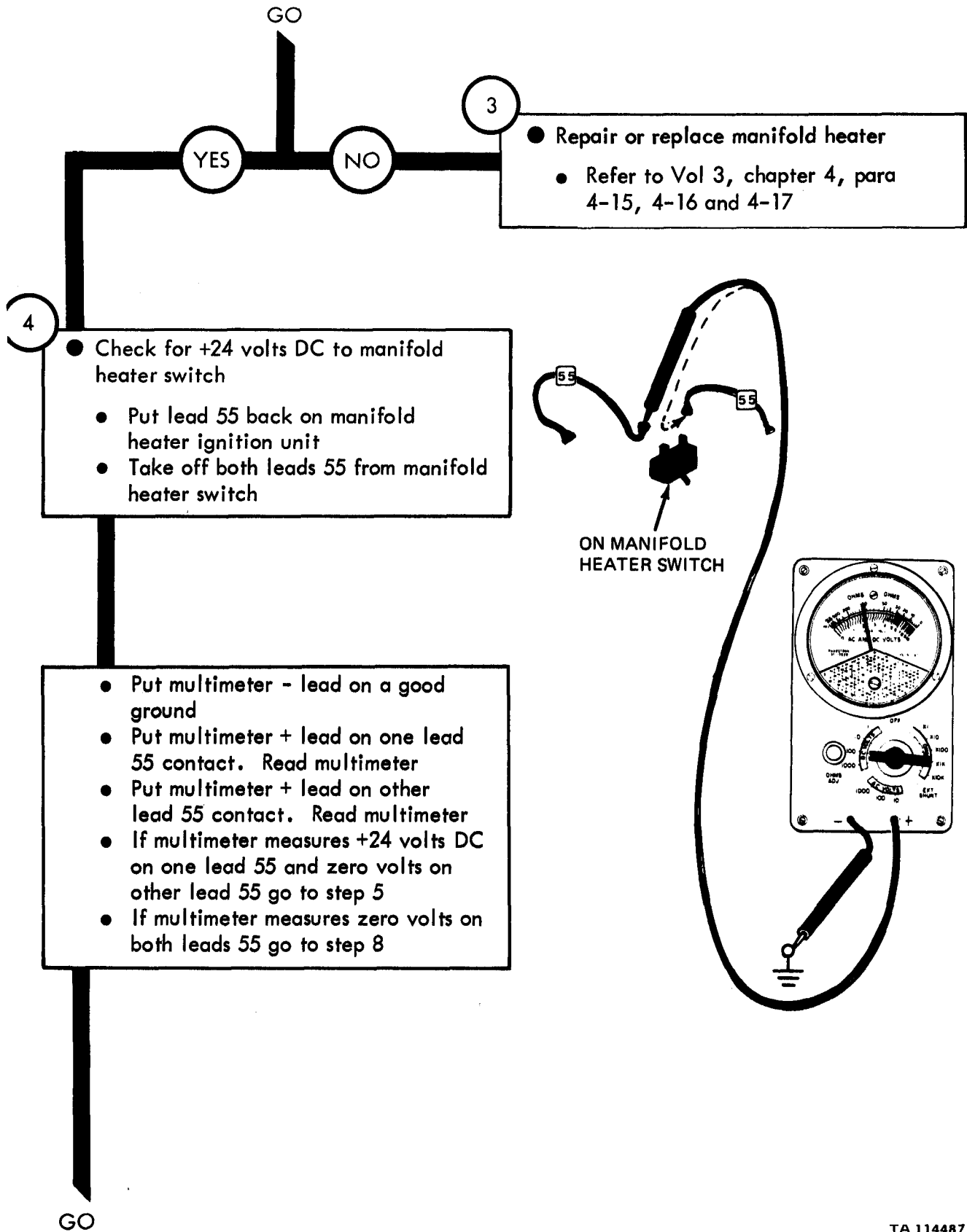

TA 114487

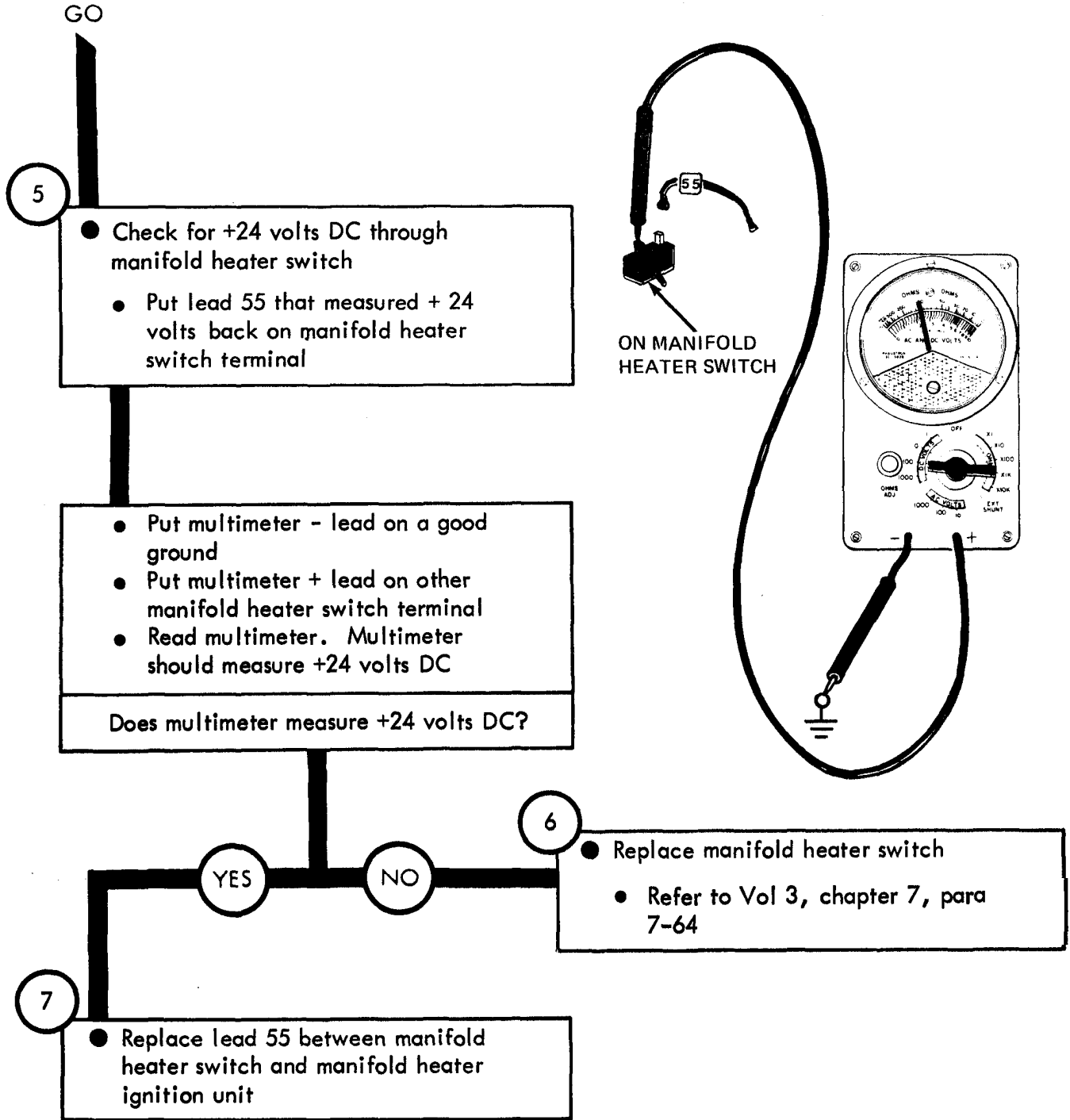

TA 114488

Figure 25-36 (Sheet 3 of 5)

From step 4

8

- Check ACCESSORY switch for +24 volts DC
 - Take off ACCESSORY switch from instrument panel. Refer to Vol 3, chapter 7, para 7-15
 - Take off lead 55 from ACCESSORY switch
 - Put lever back on ACCESSORY switch

- Put multimeter - lead on a good ground
- Put multimeter + lead on ACCESSORY switch lead 55 contact
- Read multimeter. Multimeter should measure +24 volts DC

Does multimeter measure less than +24 volts DC?

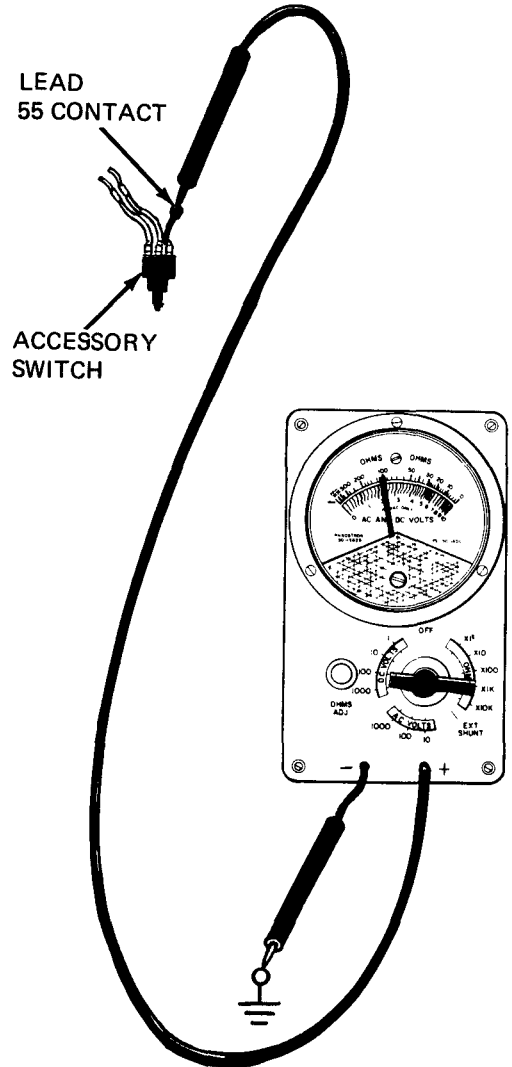

YES NO

9

- Repair or replace front harness
 - Tell direct support maintenance

GO

Figure 25-36 (Sheet 4 of 5)

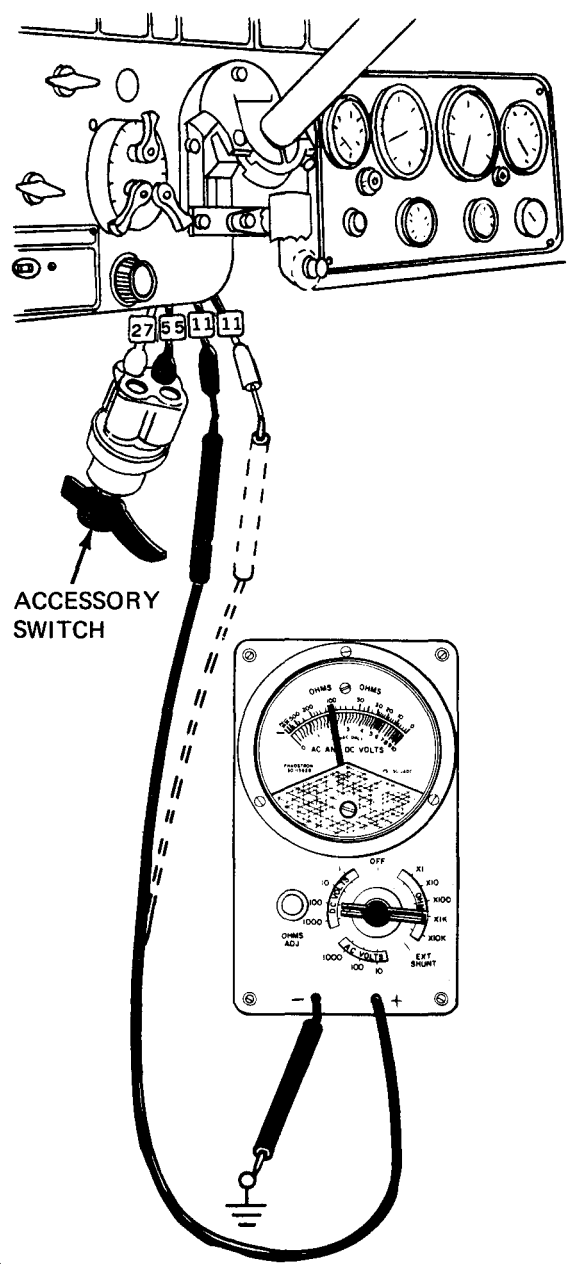
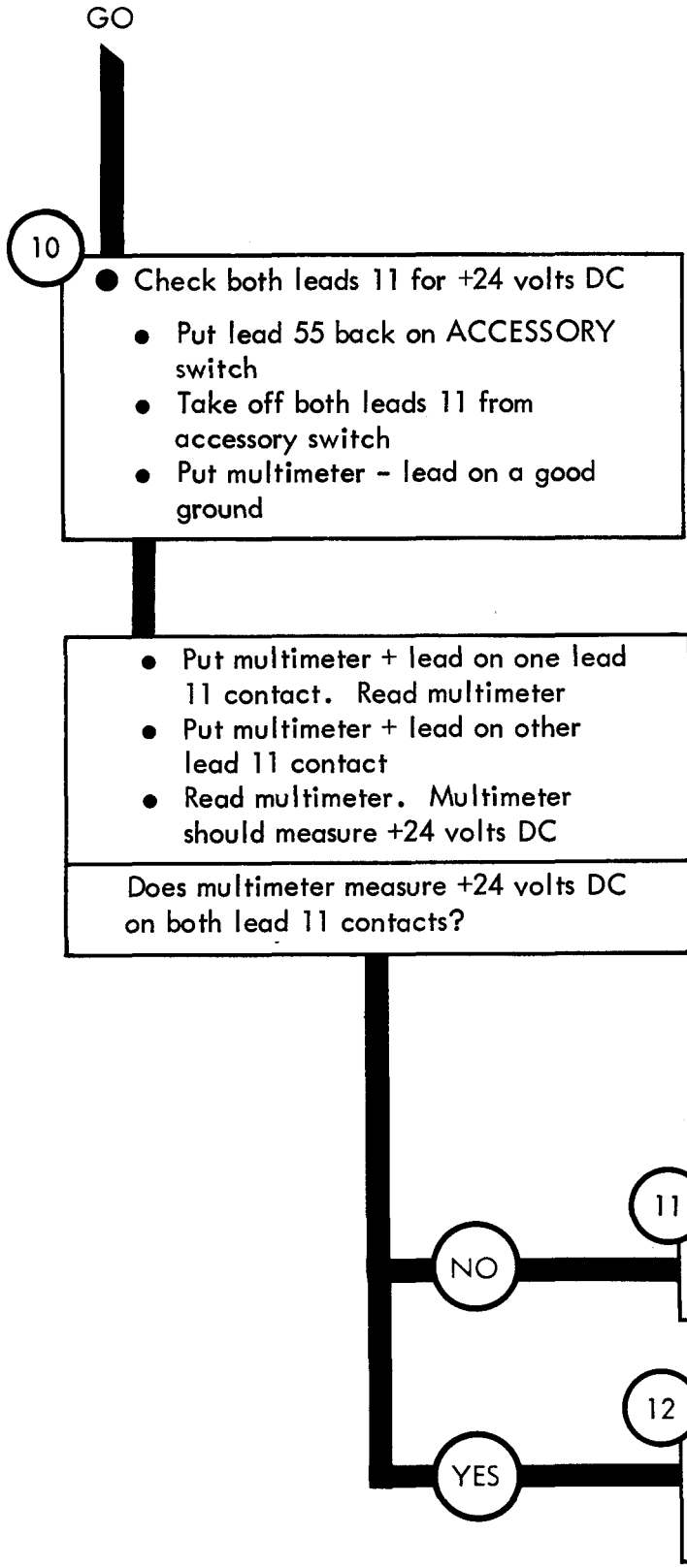

Figure 25-36 (Sheet 5 of 5)

37 Symptom

NO 24-VOLT EQUIPMENT WORKS

NOTE

When measuring voltage + 24 volts DC means a range of + 23 to + 26 volts DC

1

- Park truck
- Refer to TM 9-2320-209-10

2

- Check power supply into van
 - Take off lead 37 from circuit breaker on van body
 - Set multimeter to measure +24 volts DC. Refer to test equipment procedures index
 - Put multimeter + lead on lead 37
 - Read multimeter. Multimeter should measure +24 volts DC

Does multimeter measure +24 volts DC ?

GO

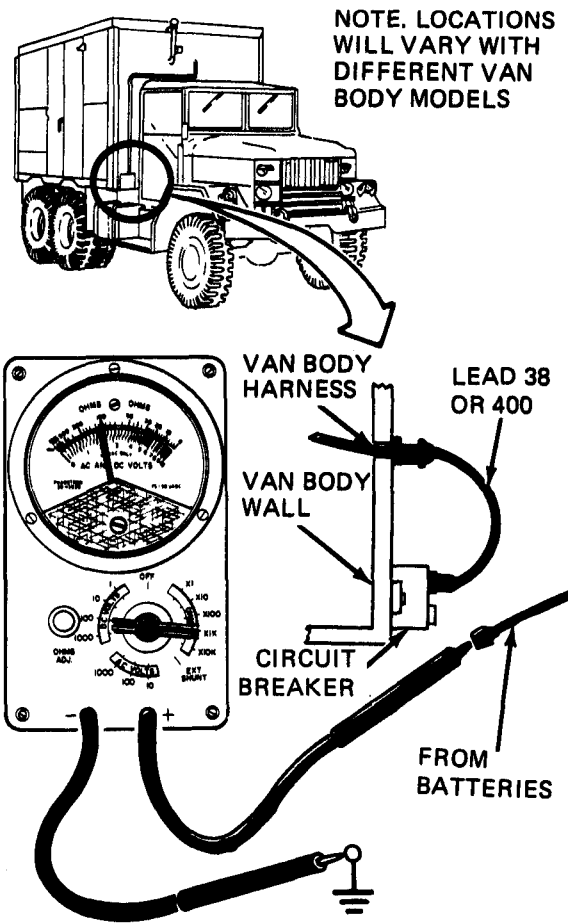

TA 114491

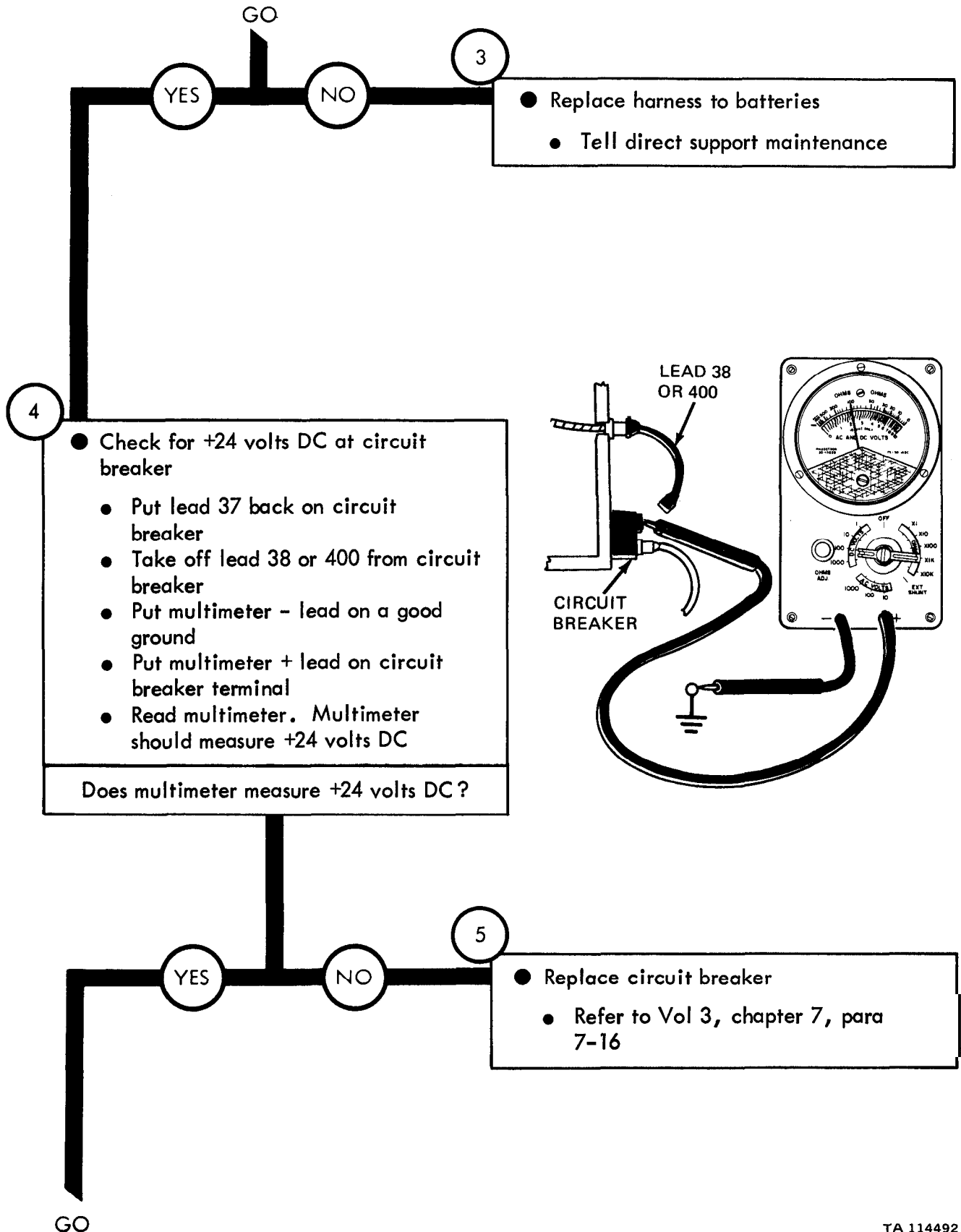

TA 114492

Figure 25-37 (Sheet 2 of 3)

GO
6

- Check lead 38 or 400 for +24 volts DC
 - Put lead 38 or 400 back on circuit breaker
 - Take lead 38 or 400 off van body harness receptacle
 - Put multimeter - lead on a good ground
 - Put multimeter + lead on lead 38 or 400
 - Read multimeter. Multimeter should measure +24 volts DC

Does multimeter measure +24 volts DC?

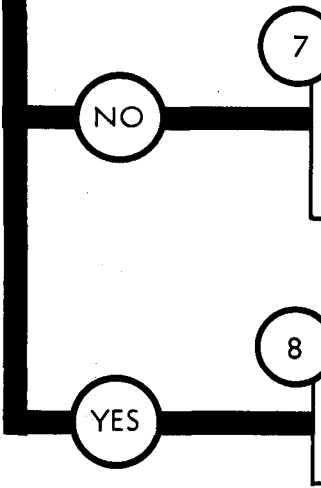
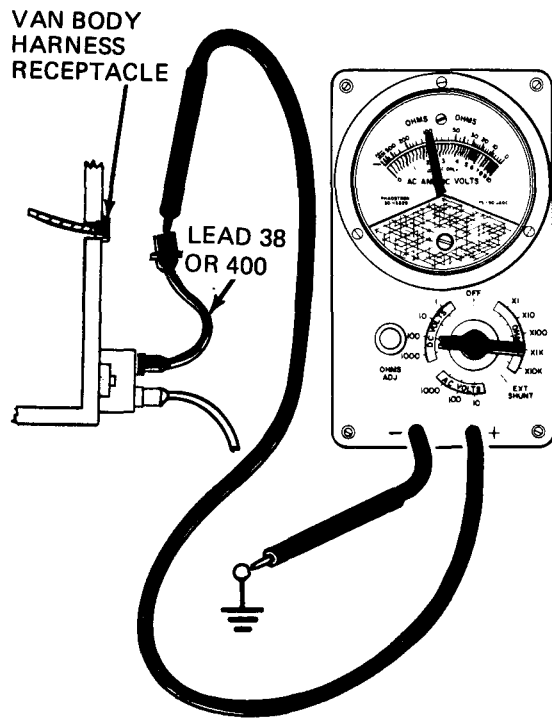

- 7
- Repair or replace lead 38 or 400
 - Refer to Vol 3, chapter 7, para 7-16

- 8
- Repair or replace van body harness
 - Tell direct support maintenance

Symptom

38 24 VOLT DOME LIGHTS DO NOT WORK

NOTE

When measuring voltage +24 volts DC means a range of +23 to +26 volts DC

1

- Park truck
- Refer to TM 9-2320-209-10

2

- Check lamp and socket assembly and clean
 - Set dome light switch to OFF
 - Take off lamp socket assembly from ceiling. Refer to Vol 3, chapter 18, para 18-65
 - Clean and tighten lamp socket assembly.
 - Put in new lamp if necessary
 - Set dome light switch to ON

Does lamp stay off?

GO

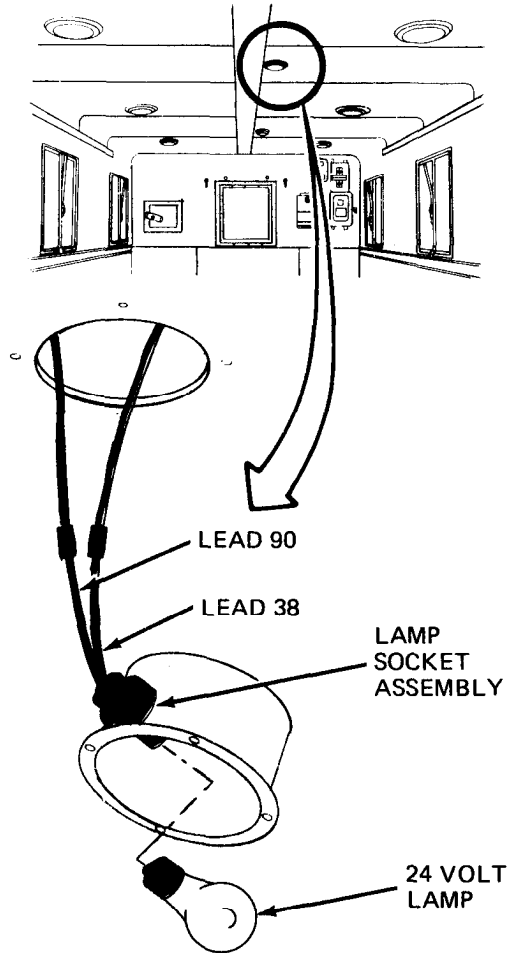

TA 114494

Figure 25-38 (Sheet 1 of 7)

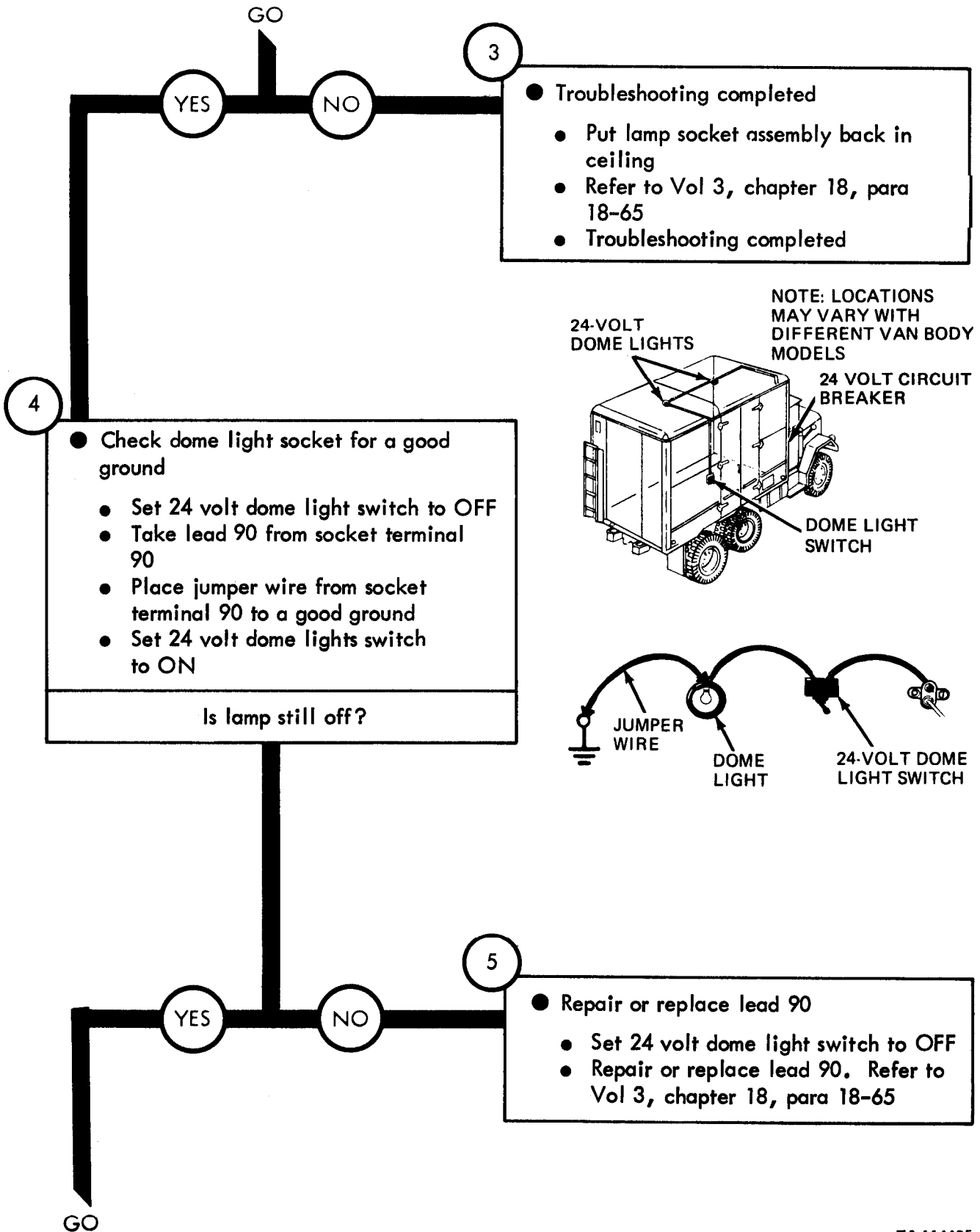

TA 114495

Figure 25-38 (Sheet 2 of 7)

GO

6

- Check for +24 volts DC to dome lamp socket assembly
 - Set 24 volt dome light switch to OFF
 - Take off jumper wire from socket terminal 90
 - Put lead 90 back on socket terminal 90
 - Take lead 38 off socket terminal 38
 - Set 24 volt dome light switch to ON

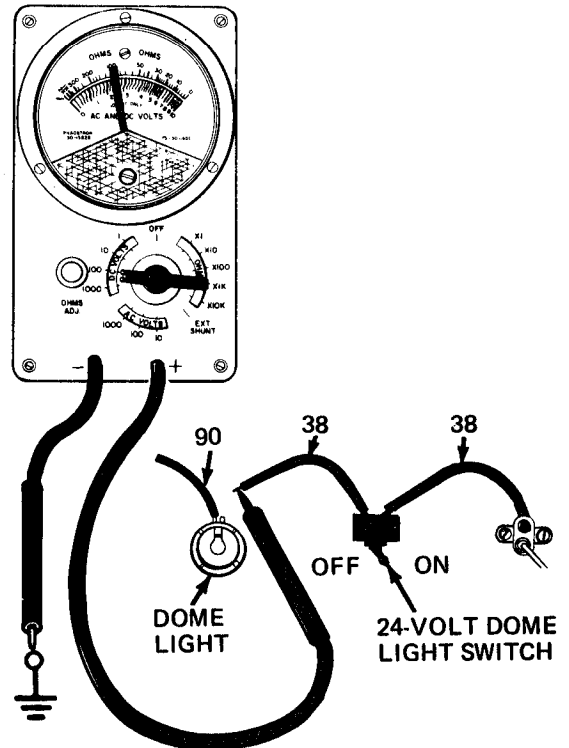

- Set multimeter to measure +24 volts DC. Refer to test equipment procedures index
- Put multimeter - lead on a good ground
- Put multimeter + lead on lead 38 contact
- Read multimeter. Multimeter should measure +24 volts DC

Does multimeter measure less than +24 volts DC?

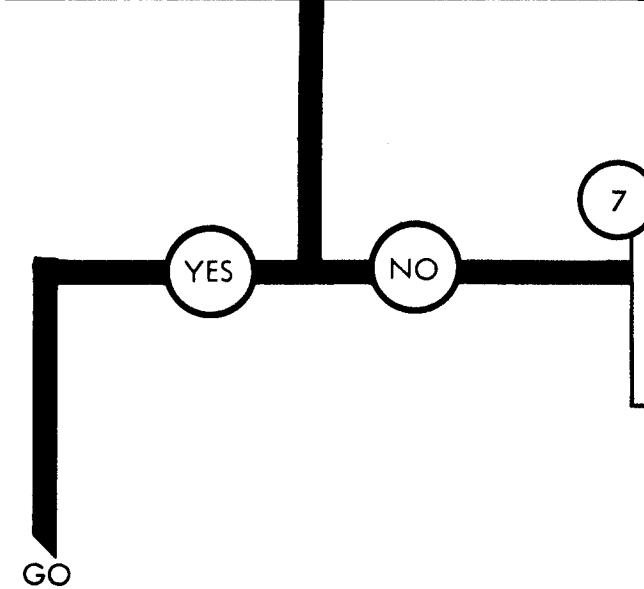

7

- Replace dome lamp socket
 - Set 24 volt dome light switch to OFF
 - Replace dome lamp socket. Refer to Vol 3, chapter 18, para 18-65

Figure 25-38 (Sheet 3 of 7)

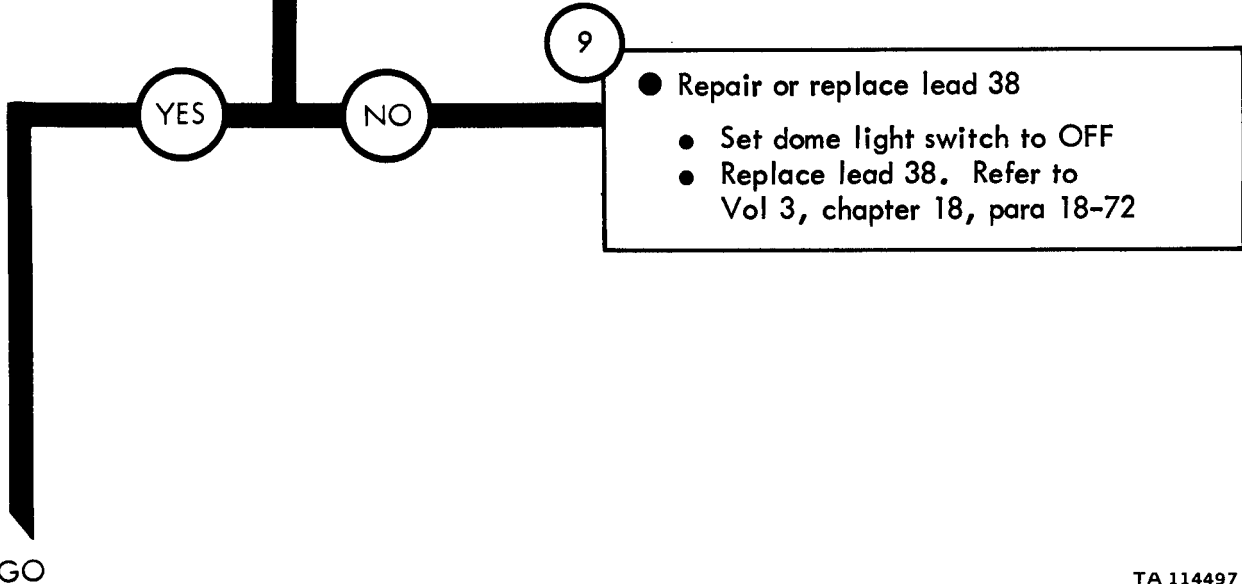
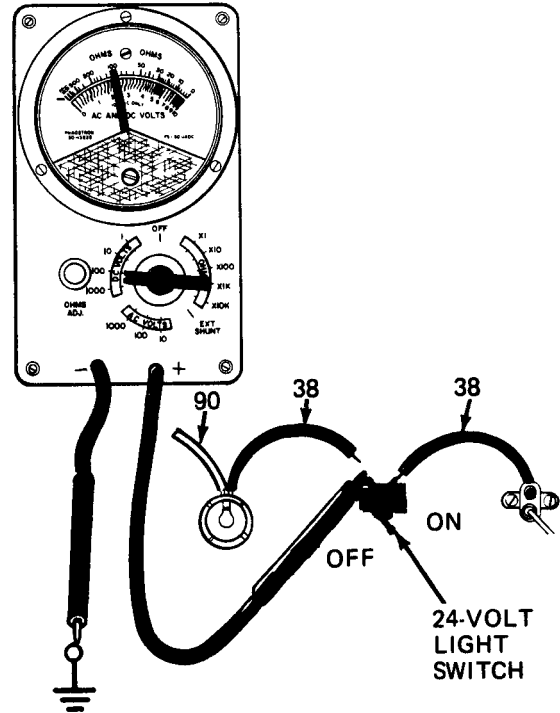
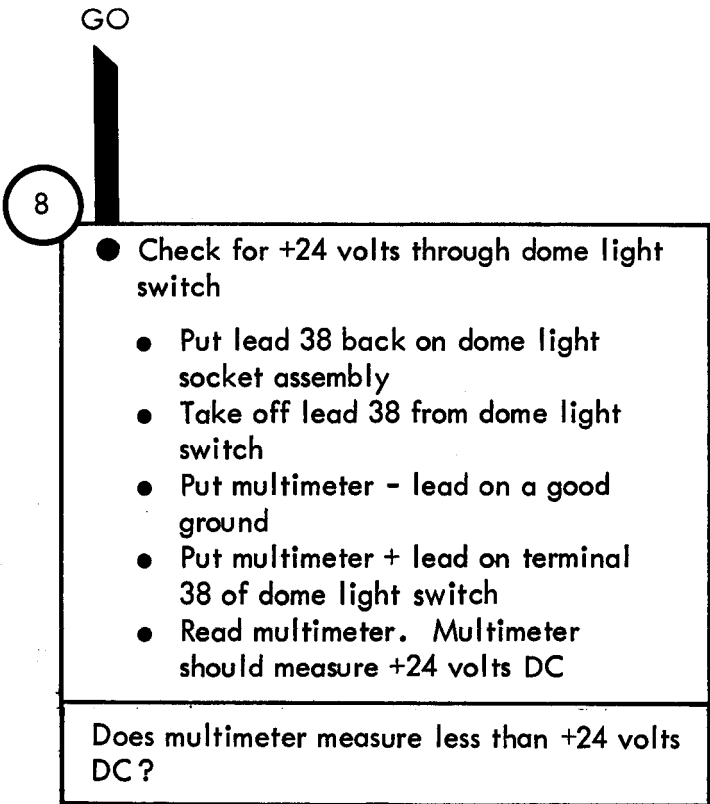

Figure 25-38 (Sheet 4 of 7)

GO

10

- Check lead 38 from circuit breaker for +24 volts DC
- Take off lead 38 from other dome light switch terminal
- Put multimeter - lead on a good ground
- Put multimeter + lead on lead 38 connector
- Read multimeter. Multimeter should measure +24 volts DC

Does multimeter measure less than +24 volts DC?

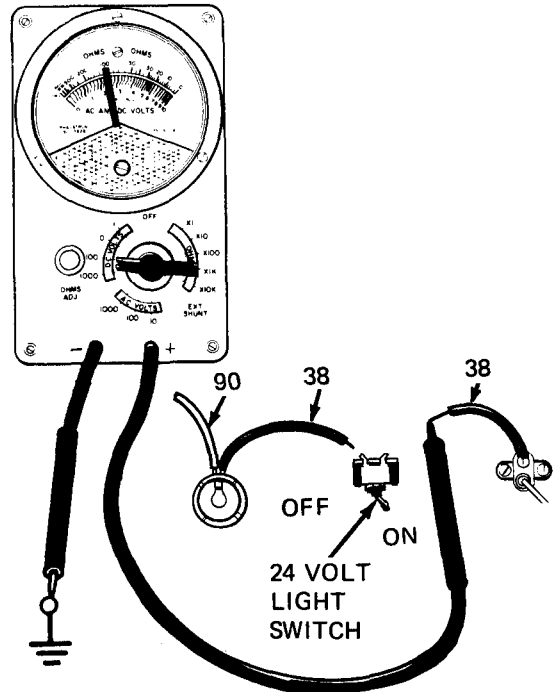

YES

NO

11

- Repair or replace dome light switch
- Replace dome light switch. Refer to Vol 3, chapter 18, para 18-72

GO

Figure 25-38 (Sheet 5 of 7)

GO

12

- Check for +24 volts DC through circuit breaker
 - Put both leads 38 back on dome light switch
 - Put dome light socket assembly back in ceiling
 - Take lead 38 from circuit breaker
 - Put multimeter - lead on a good ground
 - Put multimeter + lead on circuit breaker lead 38 connectorRead multimeter. Multimeter should measure +24 volts DC

Does multimeter measure less than +24 volts DC?

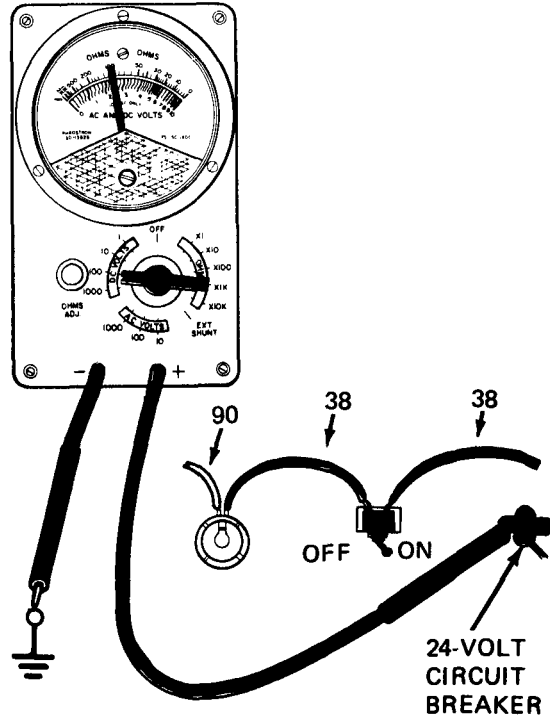

YES

NO

13

- Replace lead 38
 - Refer to Vol 3, chapter 18, para 18-72

GO

TA 114499

Figure 25-38 (Sheet 6 of 7)

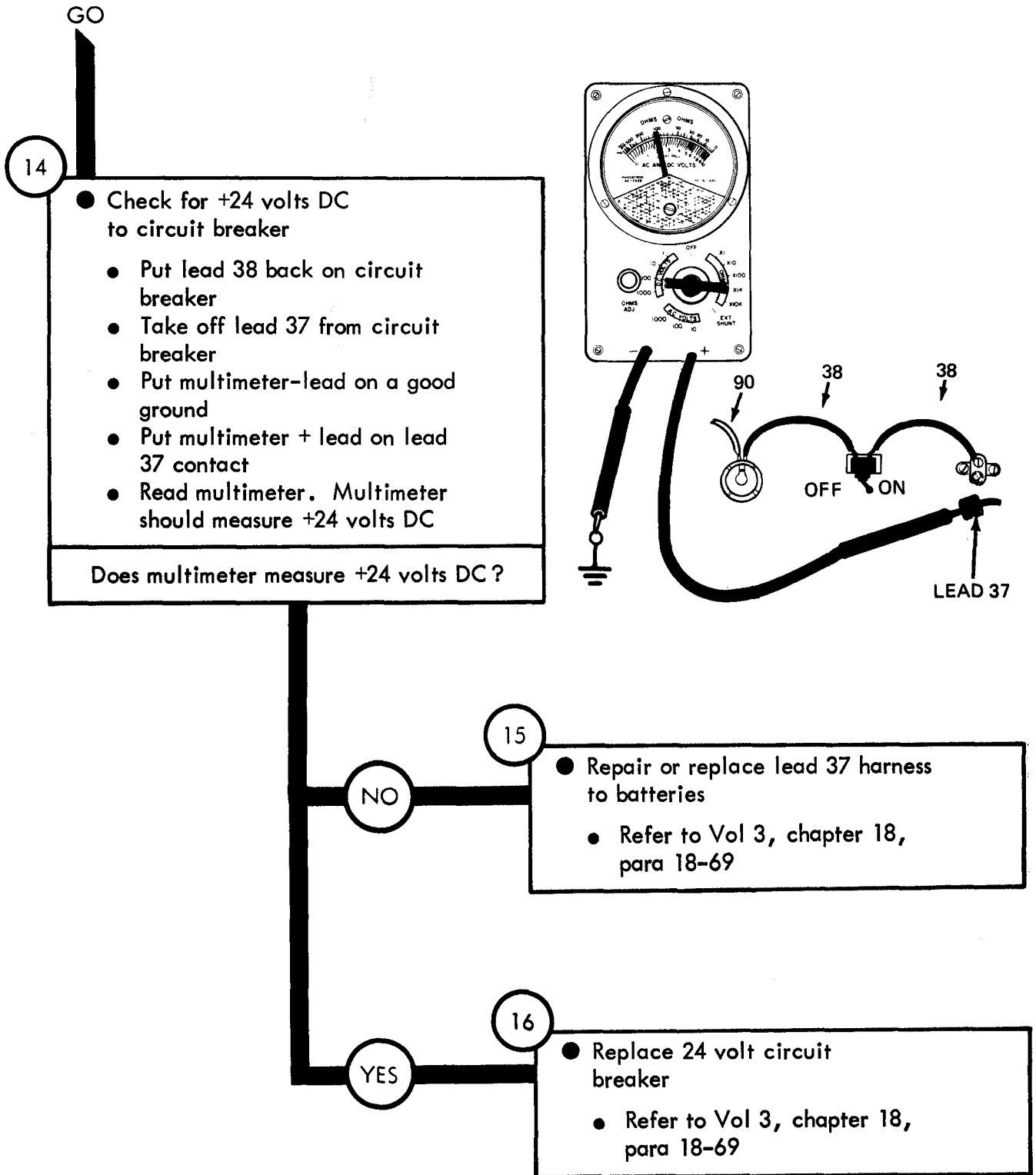

Figure 25-38 (Sheet 7 of 7)

Symptom

39

HEATER FUEL PUMP DOES NOT WORK

NOTE

When measuring voltage +24 volts DC means a range of +23 to +26 volts DC

1

- Park truck
- Refer to TM 9-2320-209-10

GO

TA 114501

Figure 25-39 (Sheet 1 of 8)

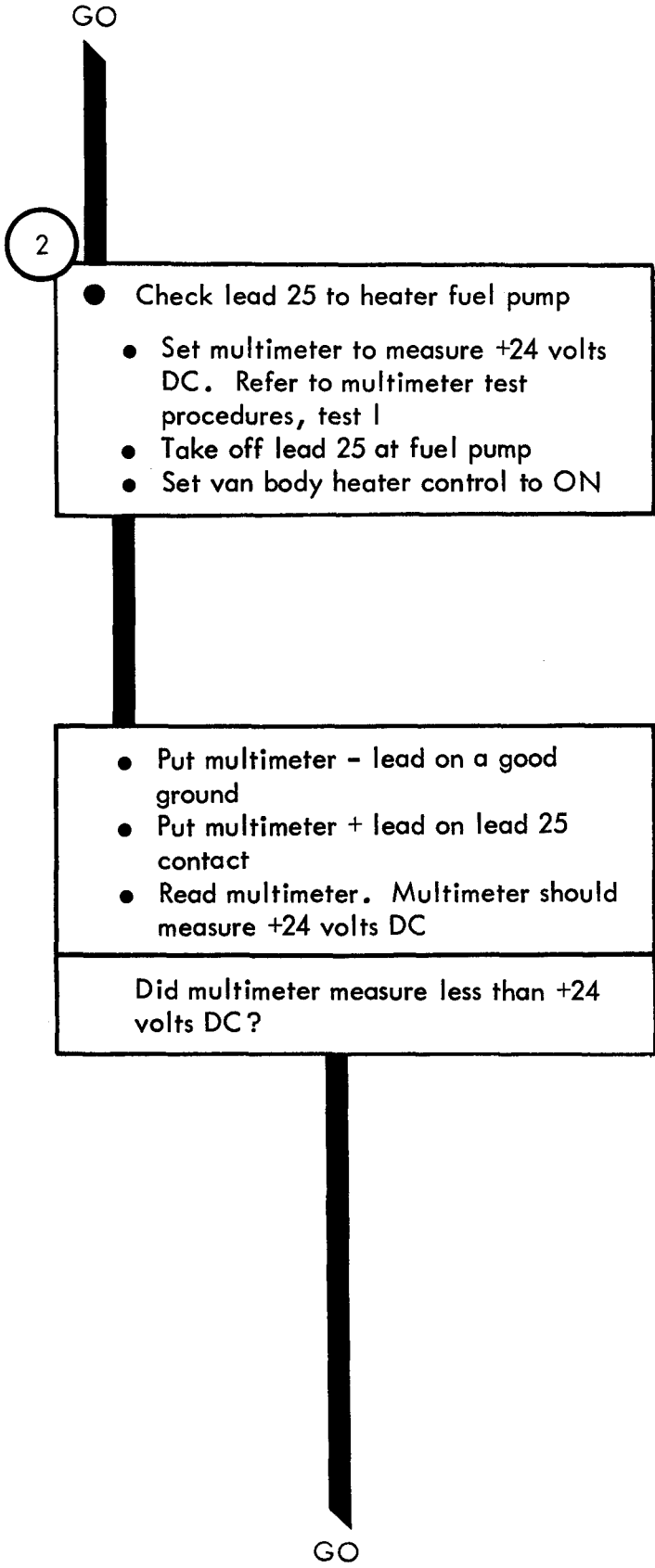

NOTE. LOCATION WILL VARY WITH DIFFERENT VAN BODY MODELS

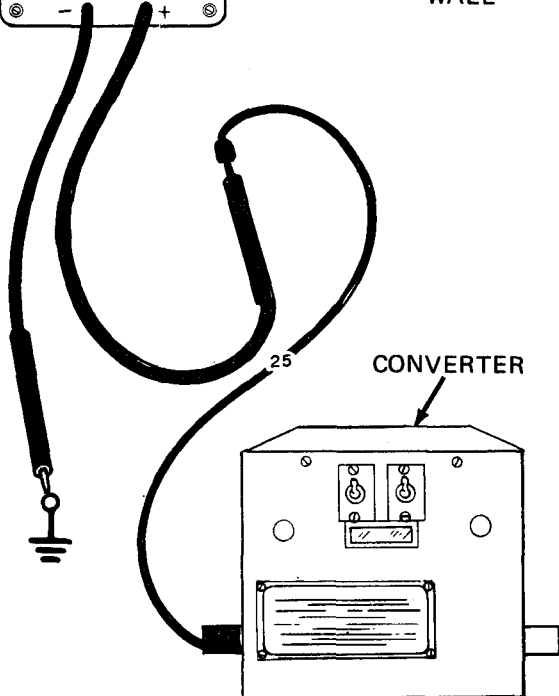
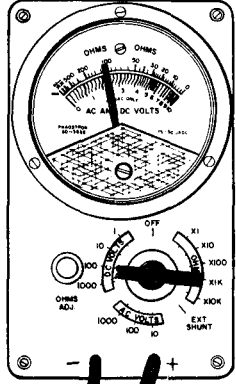
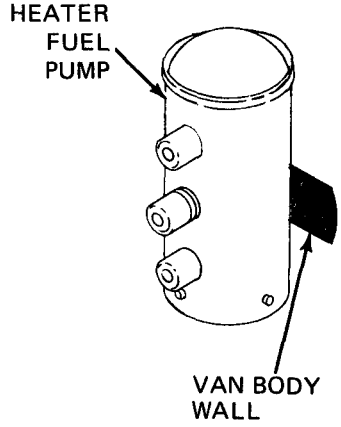
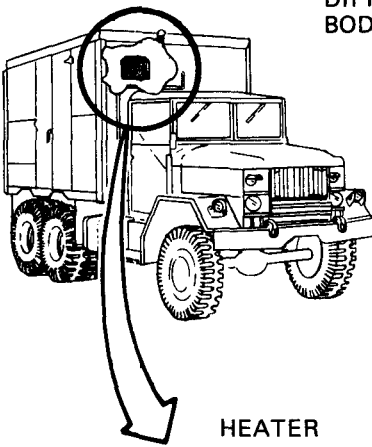
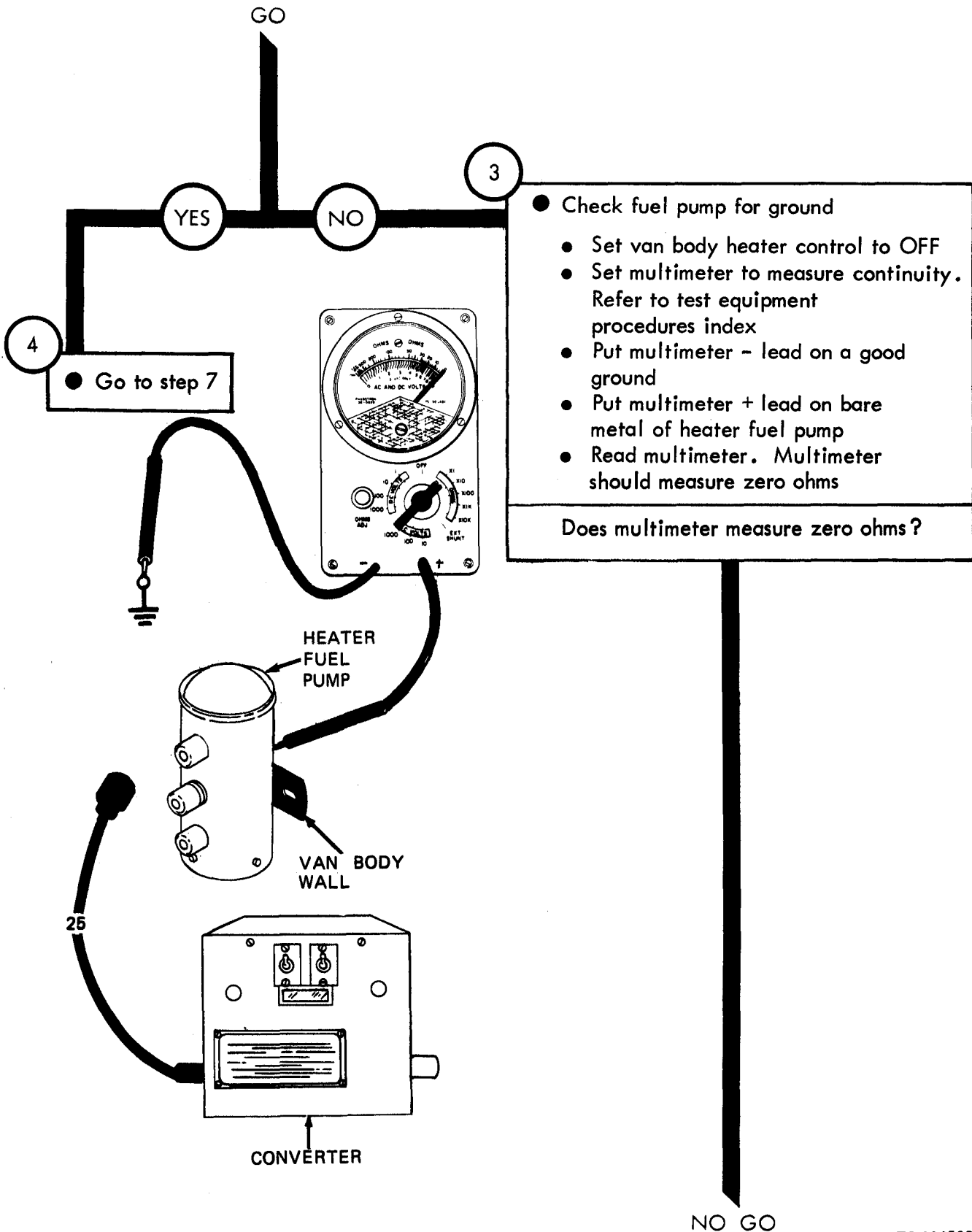
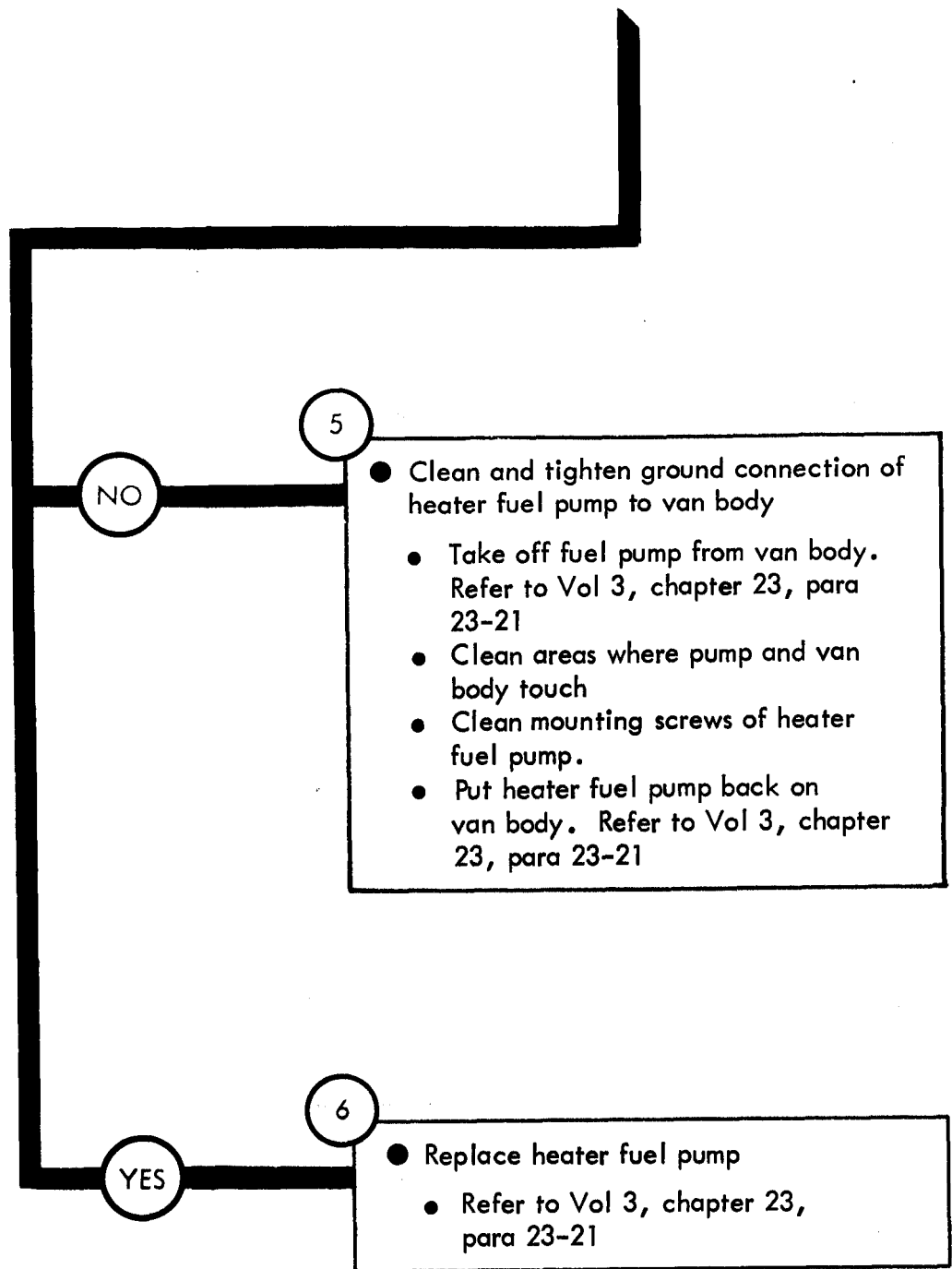

Figure 25-39 (Sheet 2 of 8)



TA 114503

NO GO



TA 114504

Figure 25-39 (Sheet 4 of 8)

From step 4

7

- Check converter for +24 volts DC
 - Take off lead 25 from converter inside van
 - Put multimeter - lead on a good ground
 - Put multimeter + lead on pin A in the converter
 - Read multimeter. Multimeter should measure +24 volts DC

Does multimeter measure less than +24 volts DC?

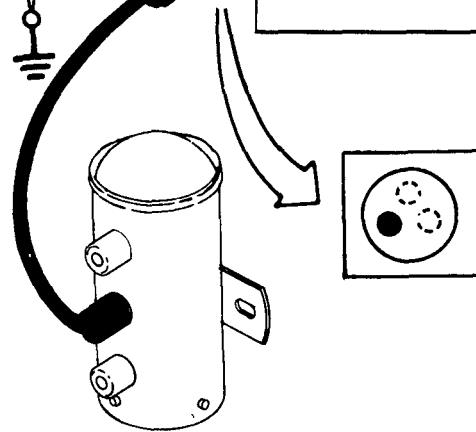
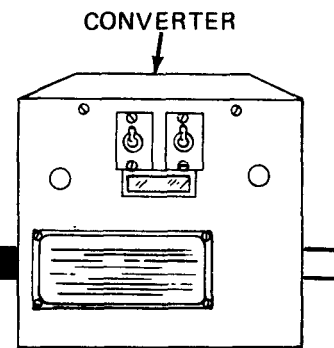
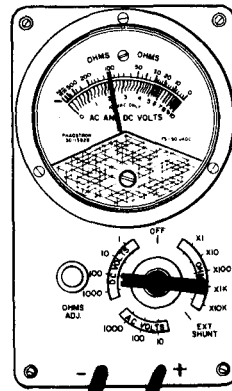

8

- Repair or replace lead 25 from converter to heater fuel pump
 - Refer to Vol 3, chapter 23, para 23-21

YES

NO

GO

Figure 25-39 (Sheet 5 of 8)

GO

WARNING

Only properly trained personnel should perform test on van body 115 volt system

The voltage present in 115 volt system can cause severe or fatal electric shock

9

- Check circuit to power converter
 - Set 115 volt power source to ON
 - Put multimeter - lead on pin B (ground) of converter
 - Put multimeter + lead on pin A of converter
 - Read multimeter. Multimeter should measure 24 volts DC

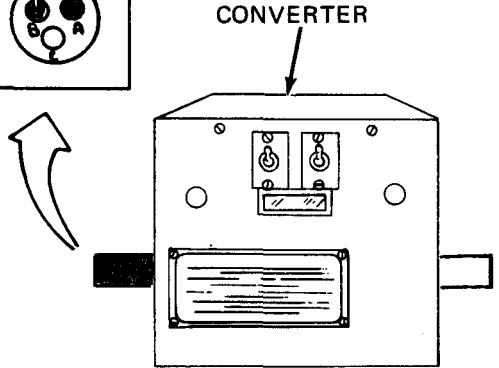
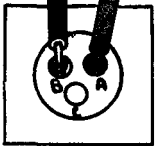
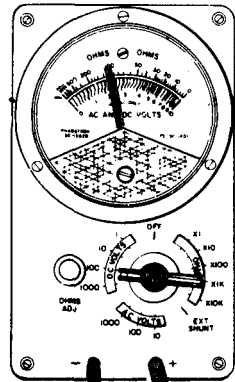

GO

Figure 25-39 (Sheet 6 of 8)

GO

NOTE. LOCATIONS WILL VARY WITH DIFFERENT VAN BODY MODELS

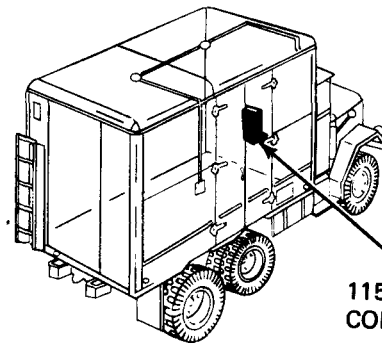

115 TO 24 VOLT CONVERTER

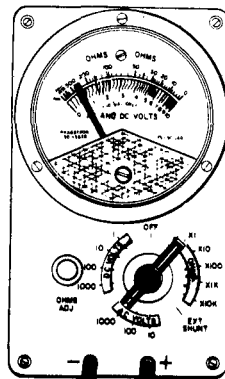

115 VOLT AC SOURCE RECEPTACLE

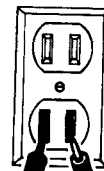

10

- If multimeter measures less than +24 volts DC check power source for 115 volts AC
- Take converter power plug from 115 volt AC power source
- Set multimeter to measure 115 volts AC. Refer to test equipment procedures index
- Put multimeter - lead in one side of source receptacle
- Put multimeter + lead in other side of source receptacle
- Read multimeter, multimeter should measure 115 volts AC

Does multimeter measure 115 volts AC?

24 VOLTS TO HEATER FUEL PUMP

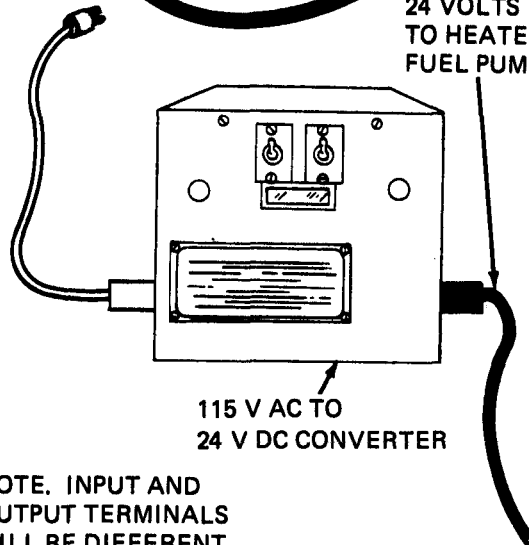

115 V AC TO 24 V DC CONVERTER

NOTE. INPUT AND OUTPUT TERMINALS WILL BE DIFFERENT ON EACH VAN BODY MODEL VARIATION

GO

TA 114507

Figure 25-39 (Sheet 7 of 8)

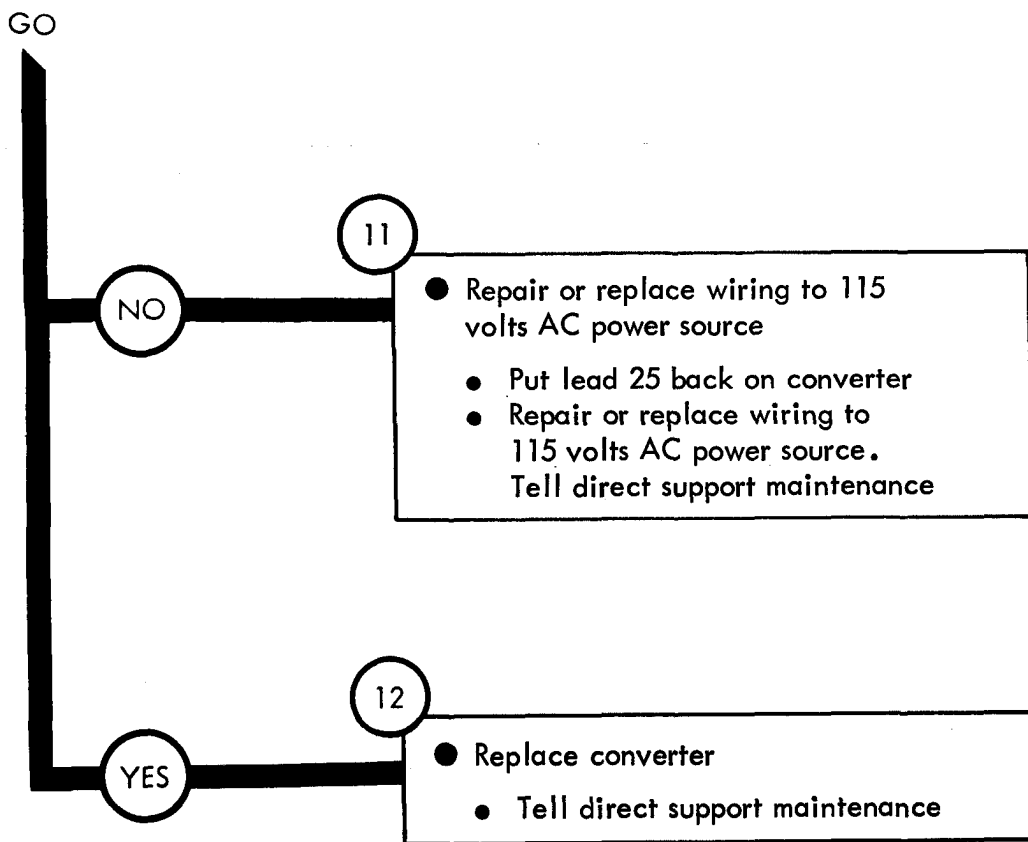

Symptom
40

ONE DOME LIGHT DOES NOT WORK, OTHER DOME LIGHTS WORK

WARNING

Only properly trained personnel should perform test on van body 115 volt systems

The voltage present in 115 volt system can cause severe or fatal electric shock

1

- Park truck
- Refer to TM 9-2320-209-10

GO

Figure 25-40 (Sheet 1 of 5)

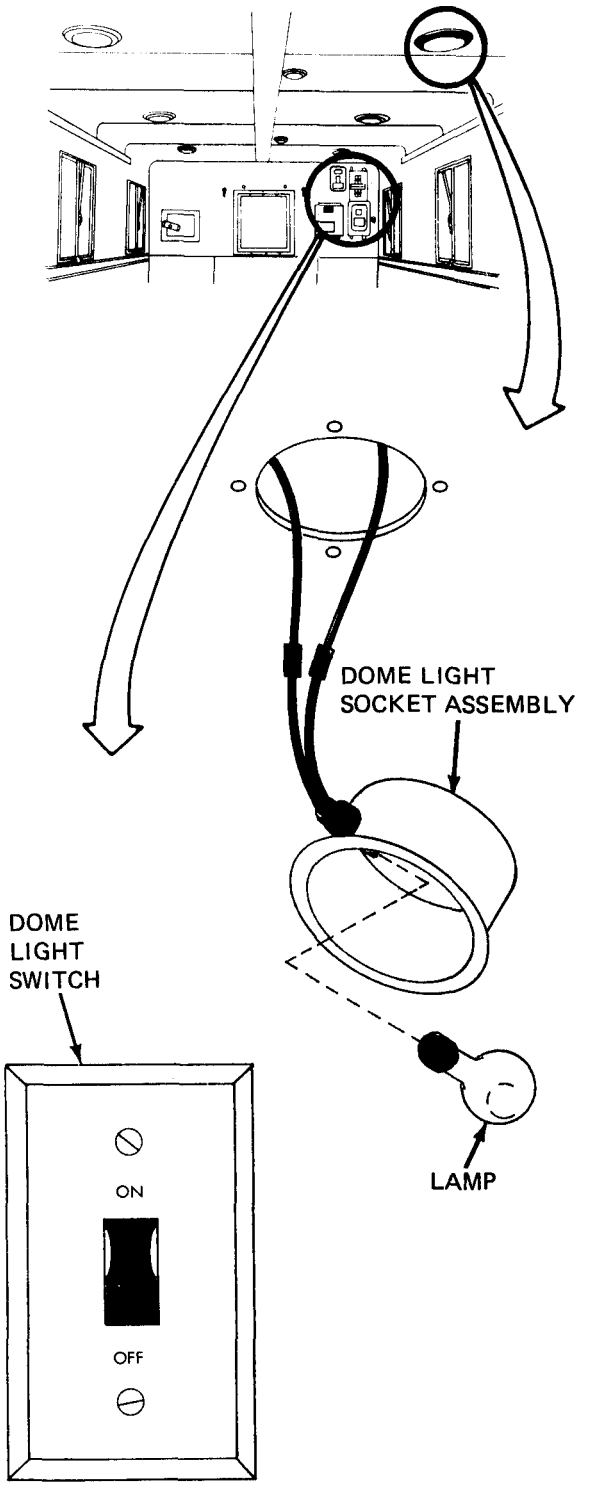
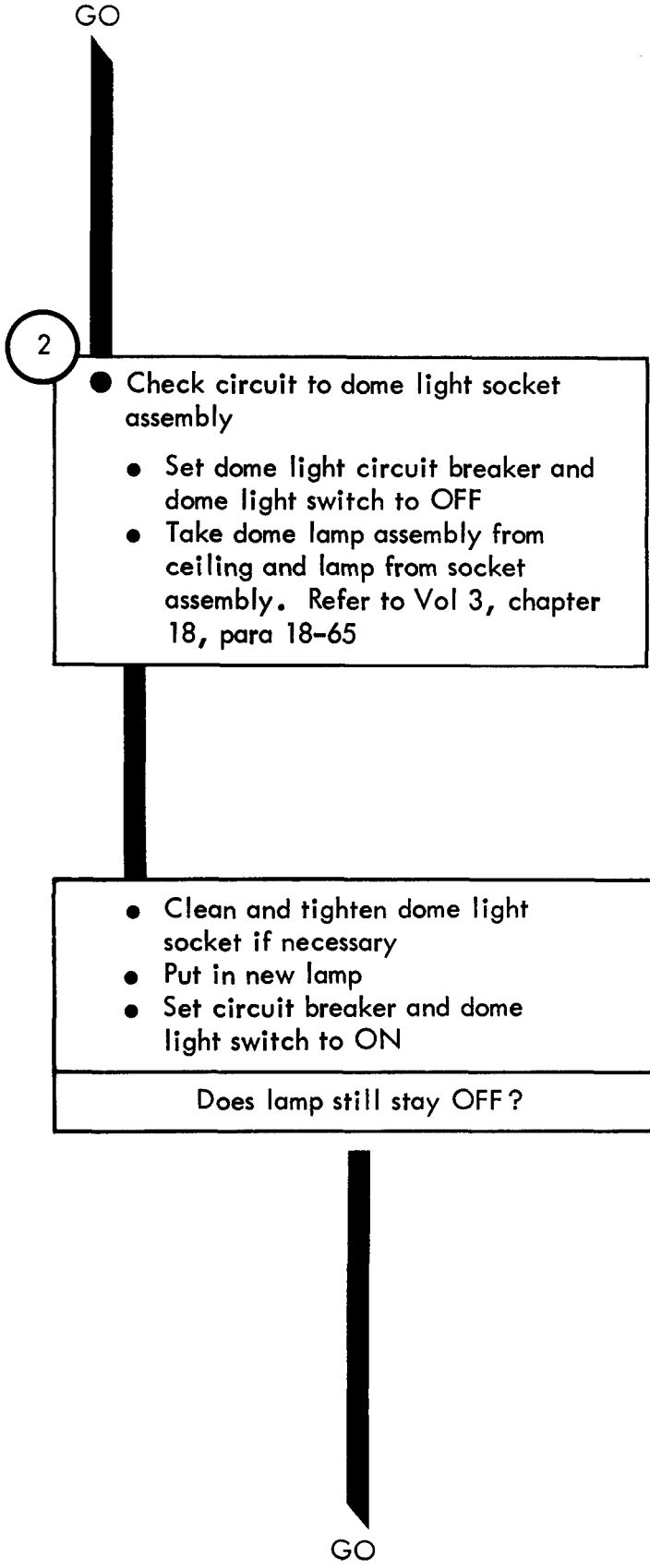
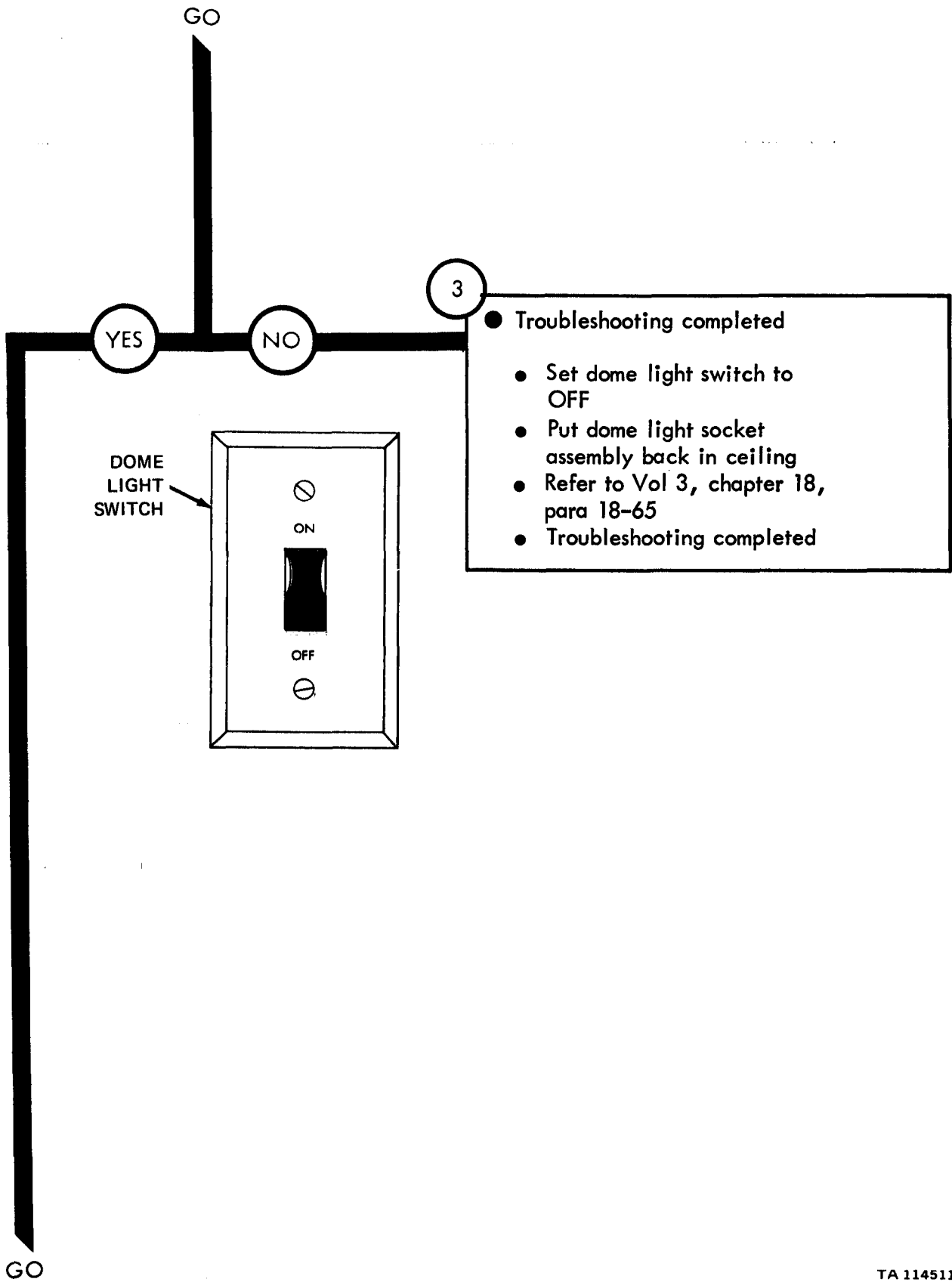

Figure 25-40 (Sheet 2 of 5)

TA 114510



TA 114511

Figure 25-40 (Sheet 3 of 5)

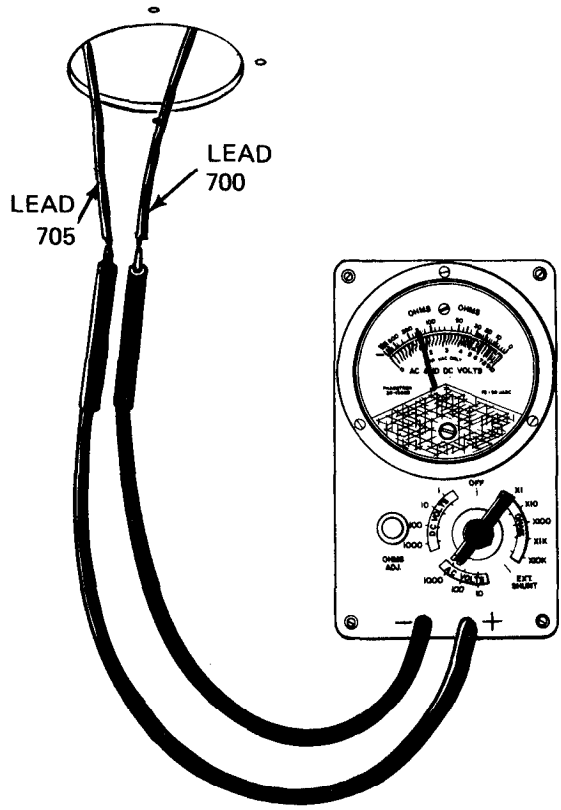
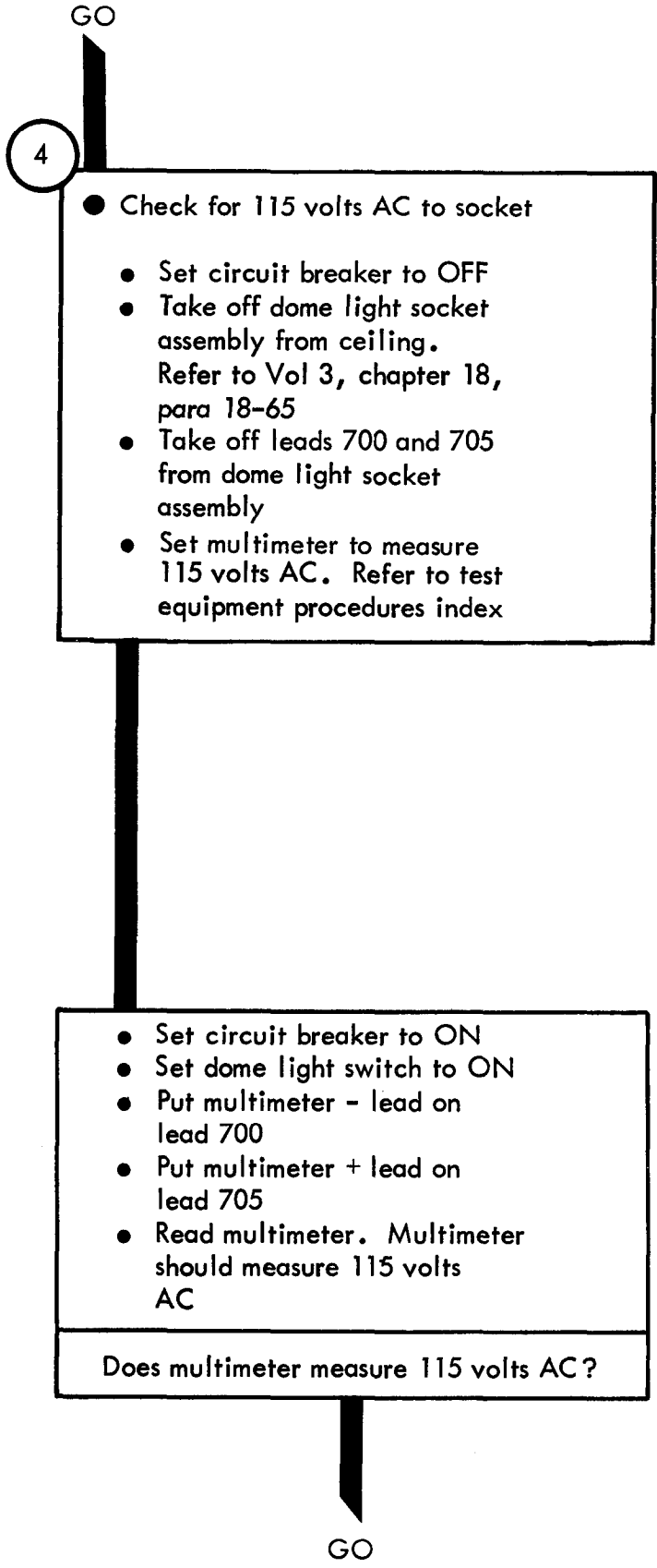
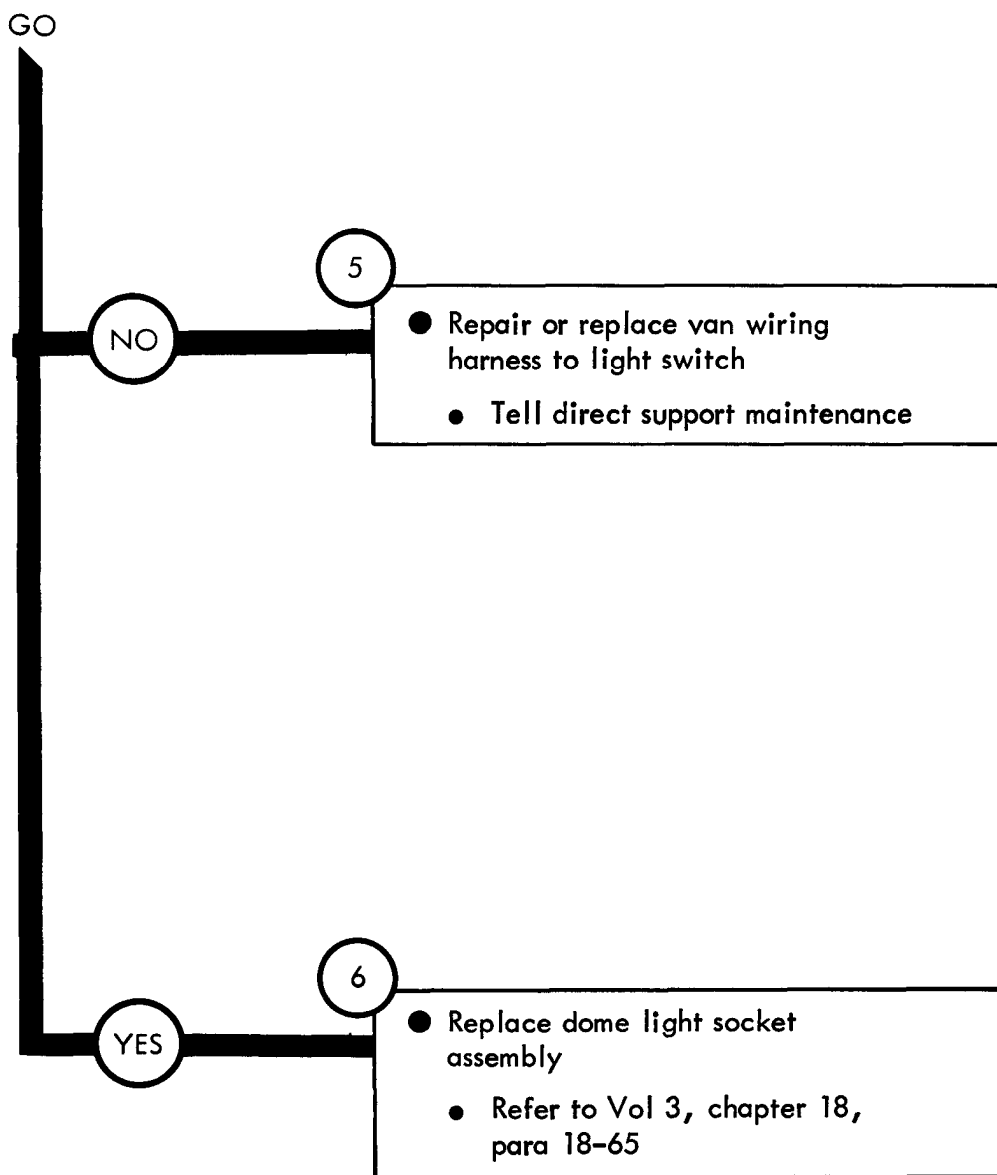

Figure 25-40 (Sheet 4 of 5)



TA 114513

Figure 25-40 (Sheet 5 of 5)

Symptom
41

ALL DOME LIGHTS DO NOT WORK

WARNING

Only properly trained personnel should perform test on van body 115 volt systems

The voltage present in 115 volt system can cause severe or fatal electric shock

1

- Park truck
- Refer to TM-9-2320-209-10

GO

GO

-CAUTION-

Do not allow any leads you take off to touch metal parts. The resulting short circuit can damage wiring and cause a fire

A shock hazard is always present

NOTE

There are two types of dome light switches. The double pole single throw; illustrated, has a lead 700 and 705 connected to it. When testing other switch refer to two 705 terminals

2

- Check dome light switch for continuity
- Set dome light switch to OFF
- Set circuit breaker to OFF
- Take off dome light switch from wall. Refer to Vol 3, chapter 18, para 18-71
- Take off leads 700 and 705 from dome light switch

GO

INSIDE FRONT OF VAN

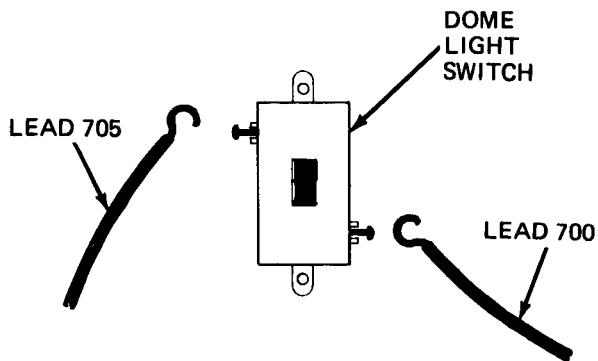
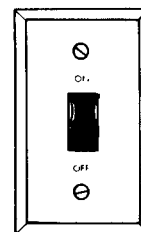
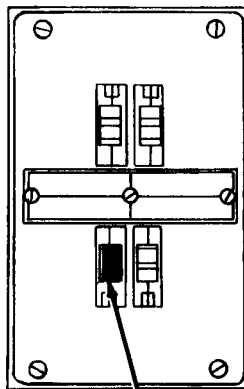
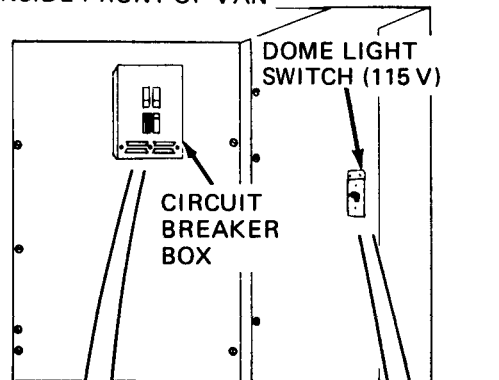

TA 114515

Figure 25-41 (Sheet 2 of 8)

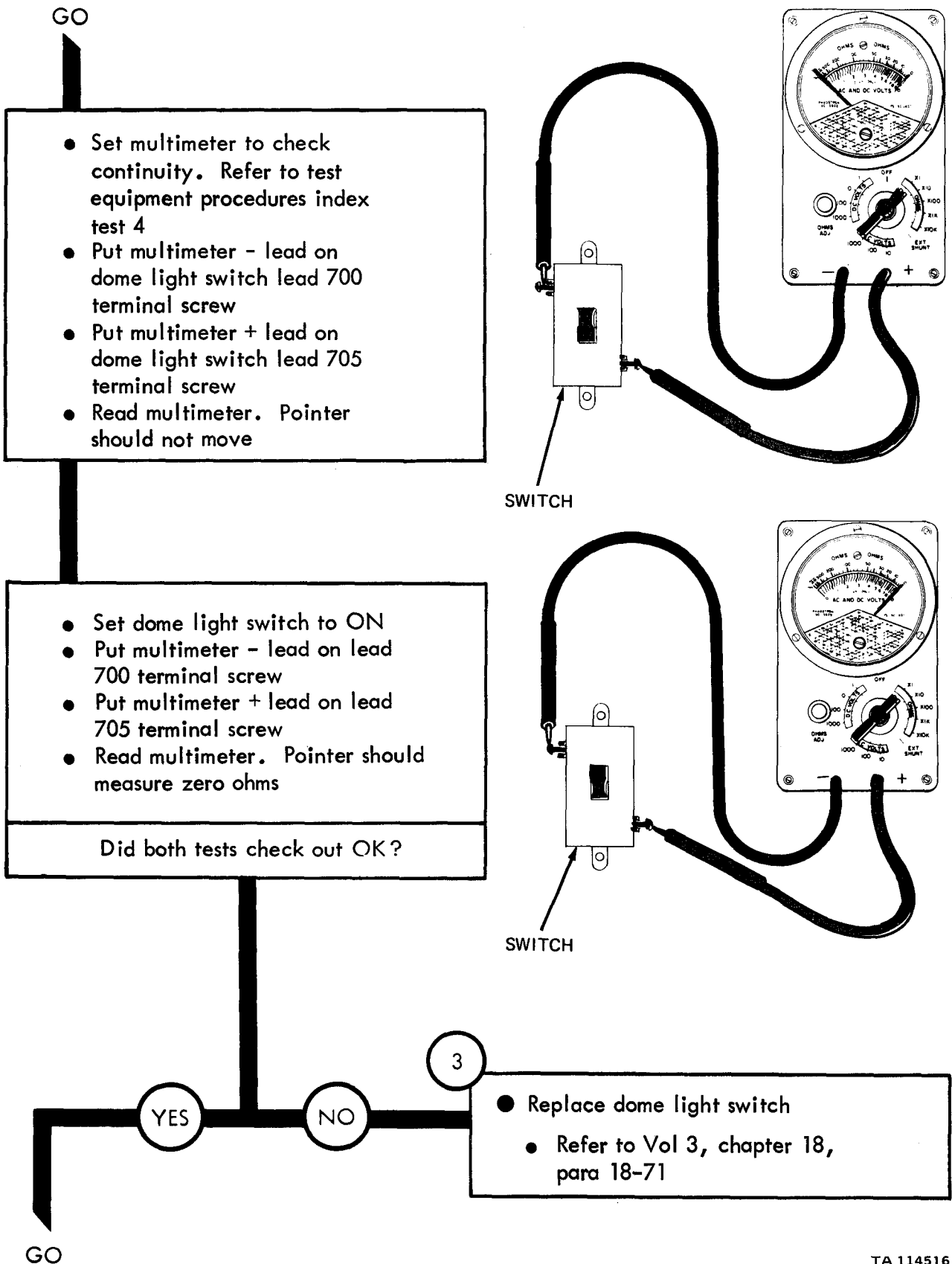

Figure 25-41 (Sheet 3 of 8)

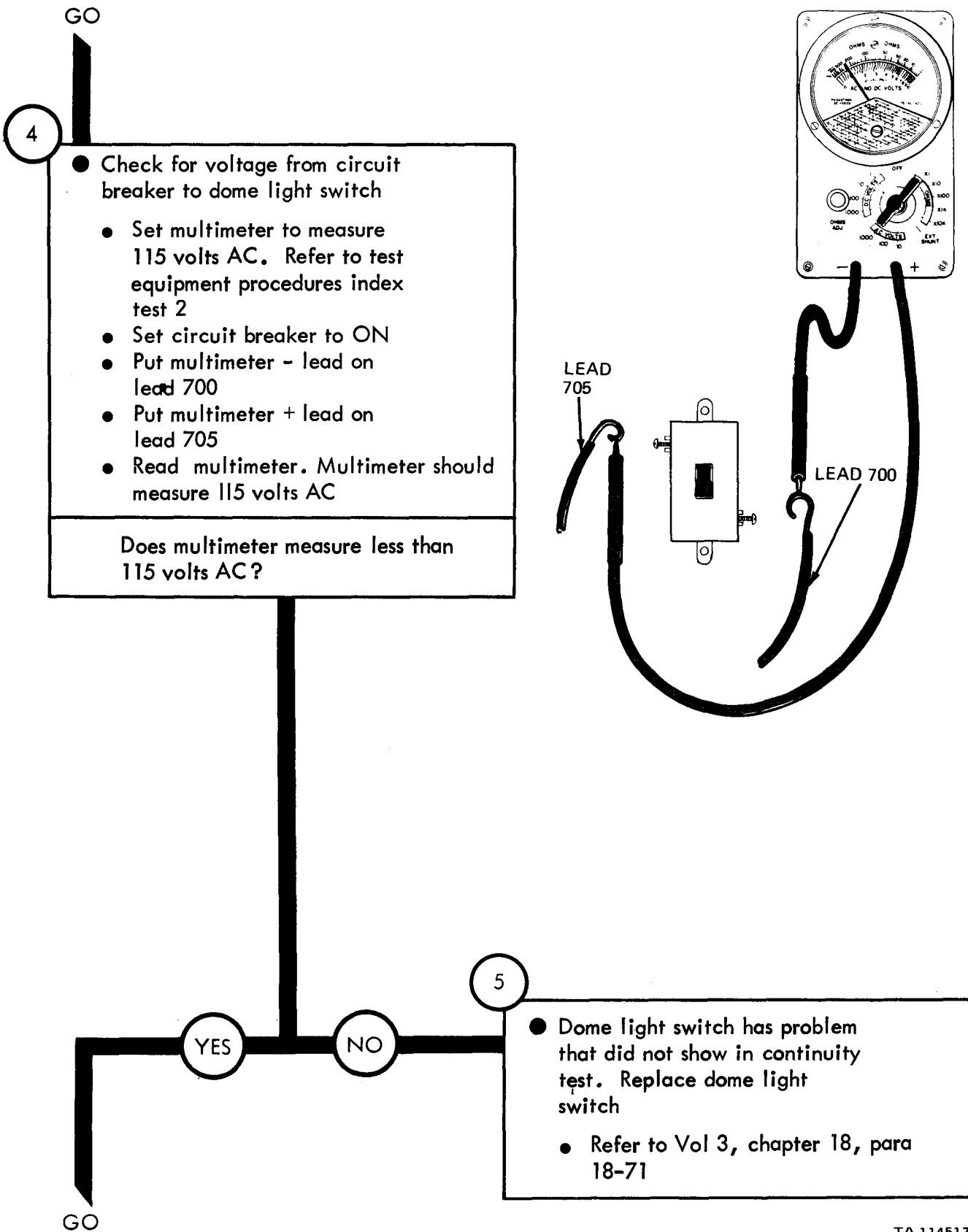

Figure 25-41 (Sheet 4 of 8)

TA 114517

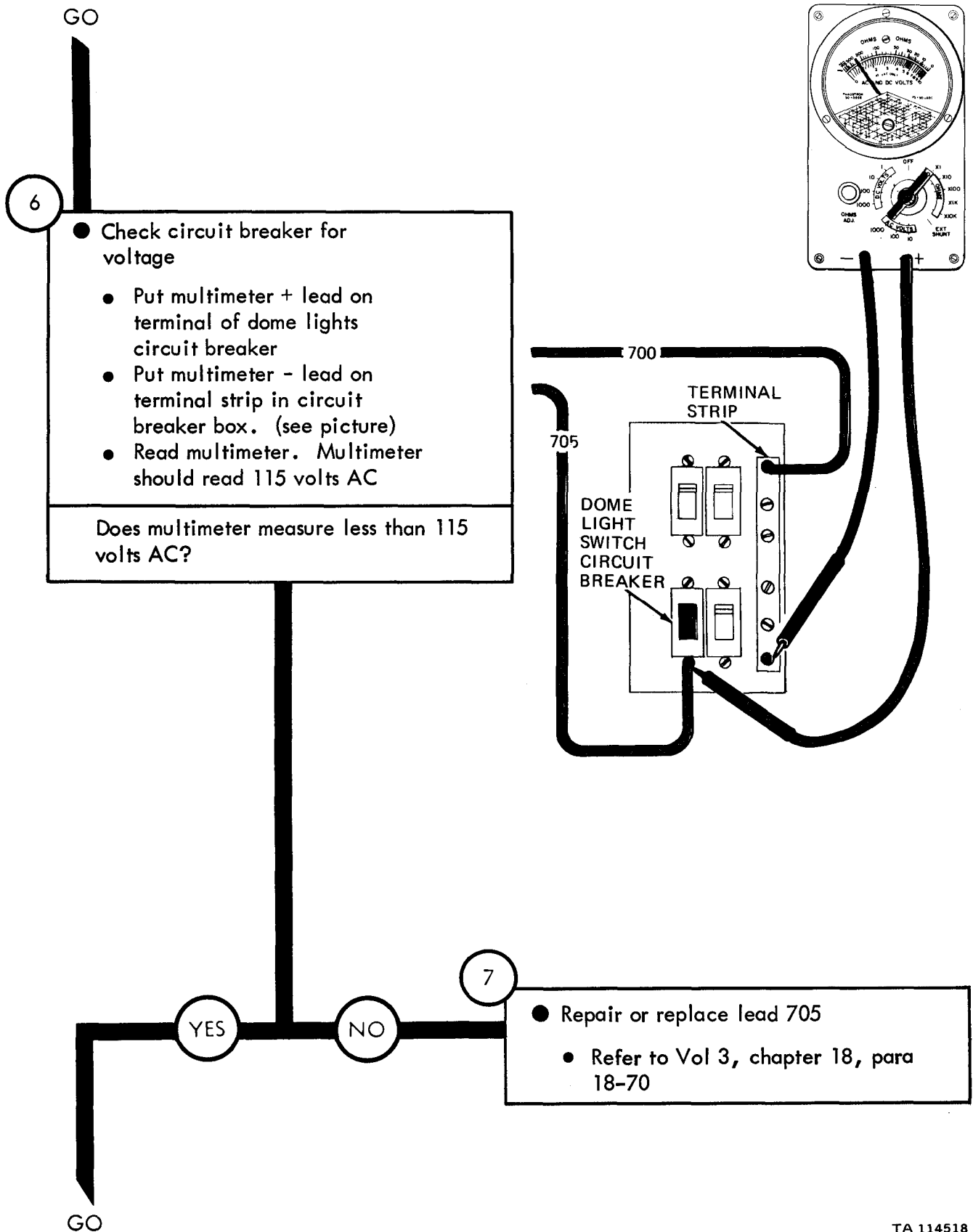

Figure 25-41 (Sheet 5 of 8)

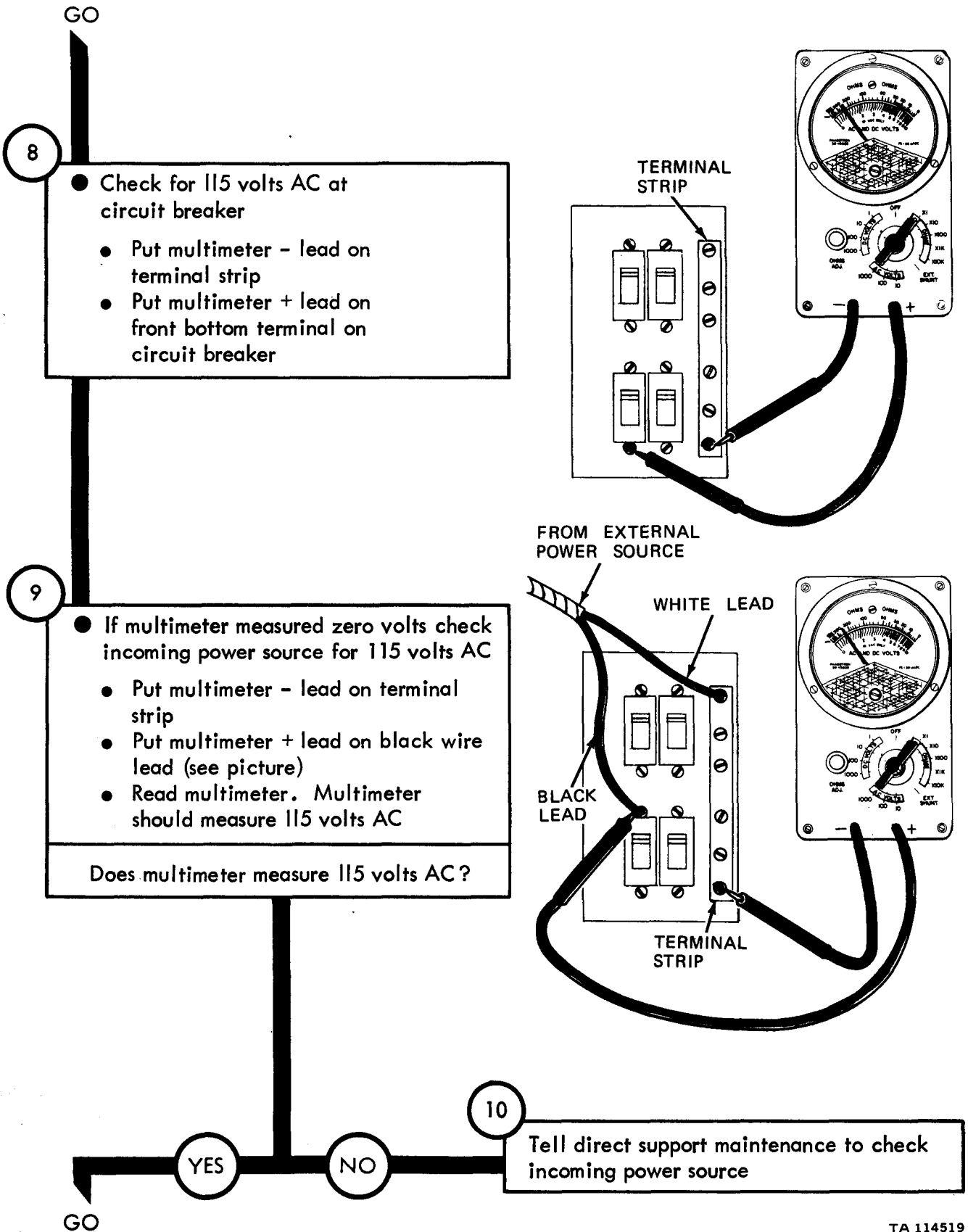

Figure 25-41 (Sheet 6 of 8)

TA 114519

GO

11

- Clean and test circuit breaker for continuity
 - Take off external power source from van. Refer to Vol 3, chapter 18, para 18-70
 - Take off circuit breaker. Refer to Vol 3, chapter 18, para 18-70
 - Clean front and rear contacts of circuit breaker. Refer to Vol 3, chapter 18, para 18-70

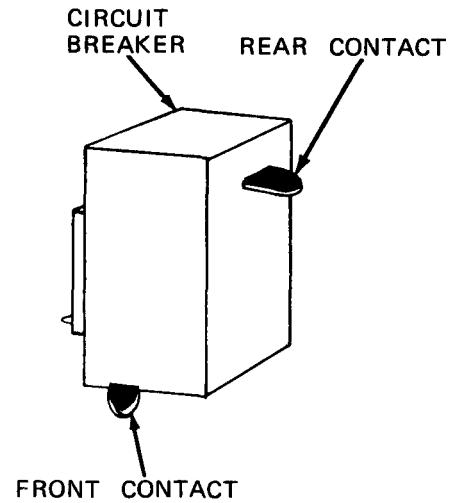

- Set multimeter to measure continuity. Refer to test equipment procedures index
- Set circuit breaker to ON
- Put multimeter + lead on front terminal of circuit breaker
- Put multimeter - lead on rear terminal of circuit breaker
- Read multimeter. Multimeter should measure less than zero ohms

Does multimeter measure zero ohms?

GO

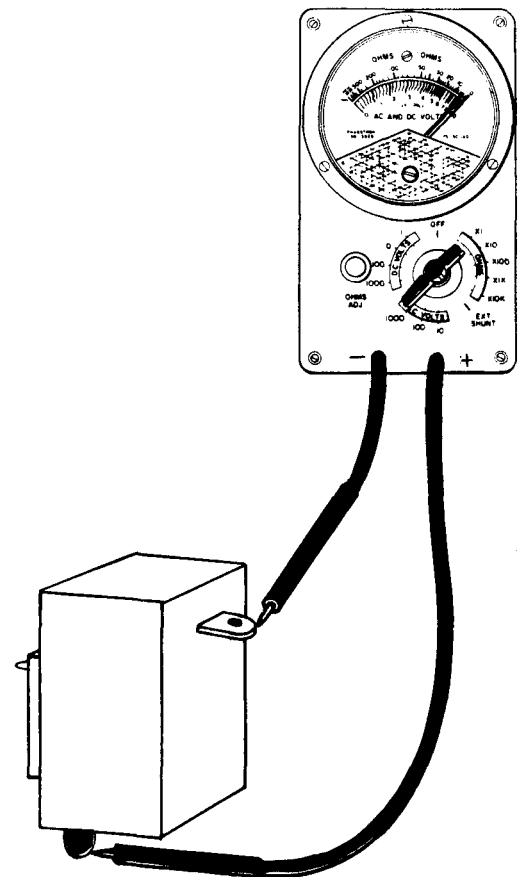

TA 114520

Figure 25-41 (Sheet 7 of 8)

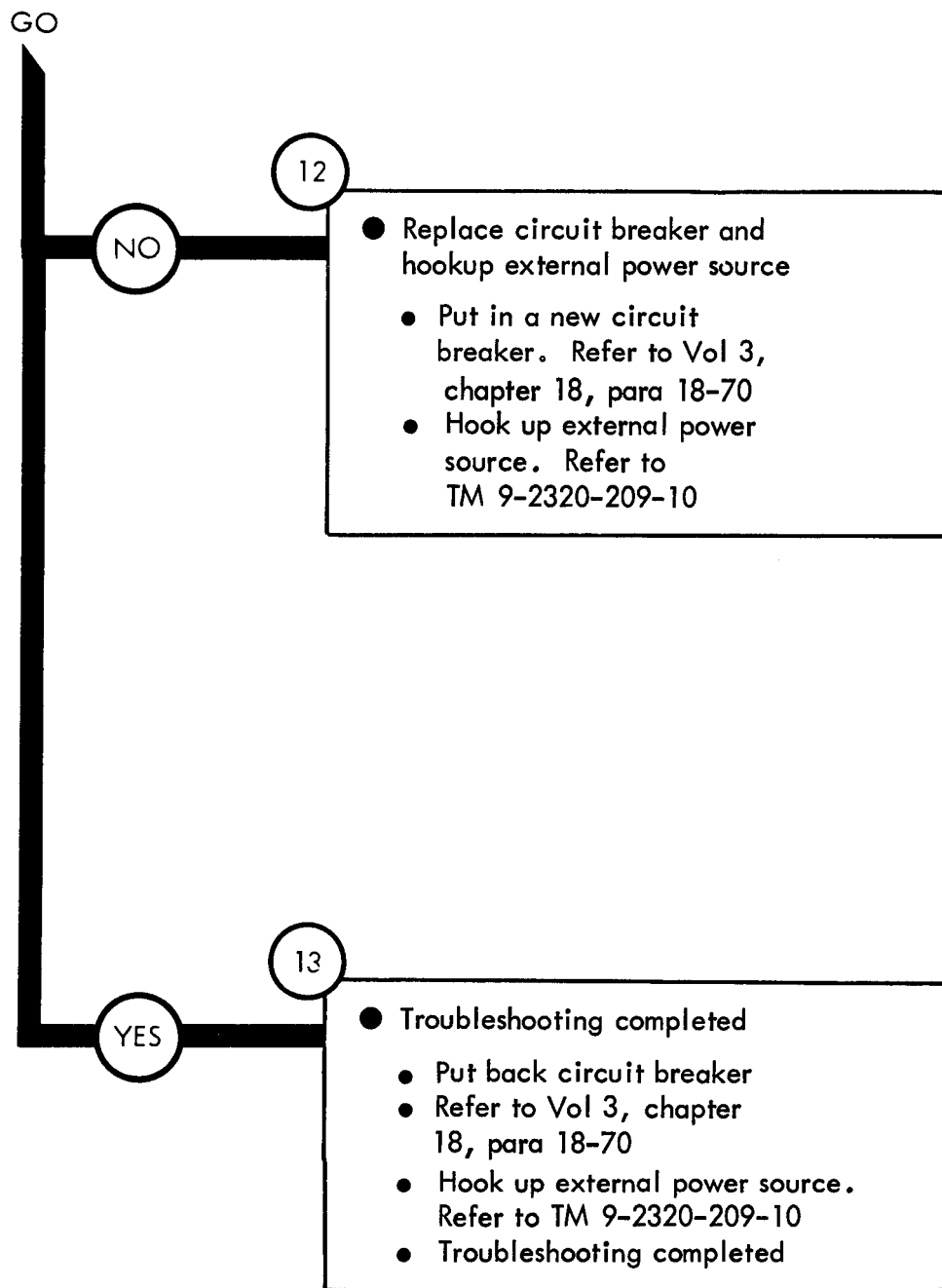

TA 114521

Figure 25-41 (Sheet 8 of 8)

42 Symptom

NO POWER AT POWER OUTPUT RECEPTACLE

— WARNING —

Only properly trained personnel should perform test on van body 115 volt system

The voltage present in 115 volt system can cause severe or fatal electric shock

1

- Park truck
- Refer to TM 9-2320-209-10

GO

TA 118027

Figure 25-42 (Sheet 1 of 6)

GO

2

- Check for 115 volts AC at power output receptacle
- Set circuit breaker to OFF
- Take off leads 700 and 702 from power outlet receptacle
- Set multimeter to measure 115 volts AC. Refer to test equipment procedures index

- Set circuit breaker to ON
- Put multimeter - lead on lead 700
- Put multimeter + lead on lead 702
- Read multimeter. Multimeter should measure 115 volts AC

Does multimeter measure less than 115 volts AC?

YES

NO

3

- Replace power output receptacle
- Set circuit breaker to OFF
- Replace power output receptacle. Tell direct support maintenance

GO

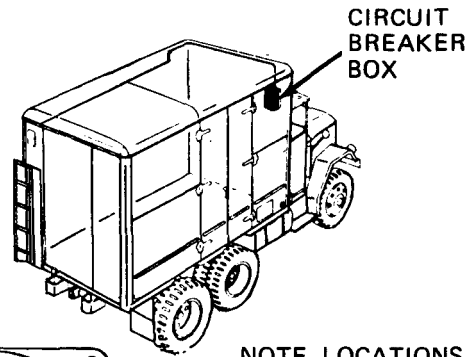

NOTE. LOCATIONS WILL VARY WITH DIFFERENT VAN BODY MODELS

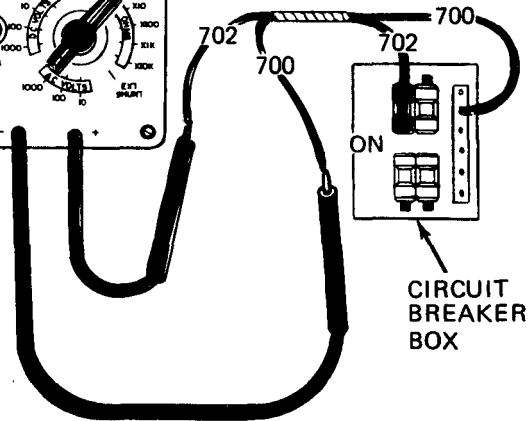
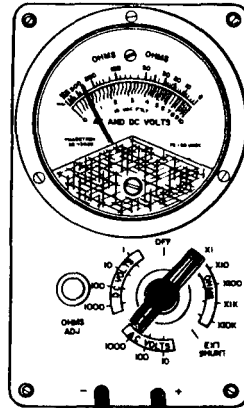

Figure 25-42 (Sheet 2 of 6)

GO

4

0 Check for 115 volts AC to power outlet receptacle

- Put **multimeter** - lead on terminal strip
- Put **multimeter** + lead on circuit breaker
- Read **multimeter**. Multimeter should measure 115 volts AC

Did **multimeter** measure less than 115 volts AC?

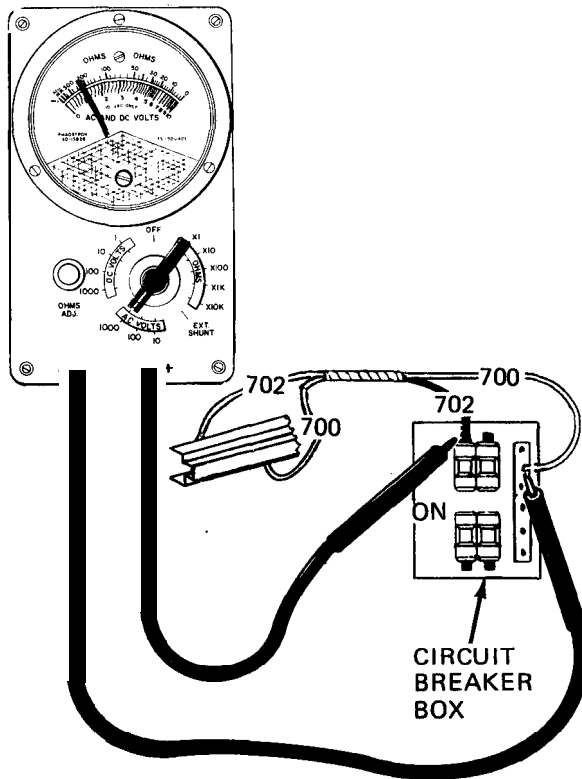

YES

NO

6

● Go to step 10

5

- Check for 115 volts AC at circuit breaker
- Put loads 700 and 702 back on power **receptacle**
- Put **multimeter** - lead on terminal strip (see picture)

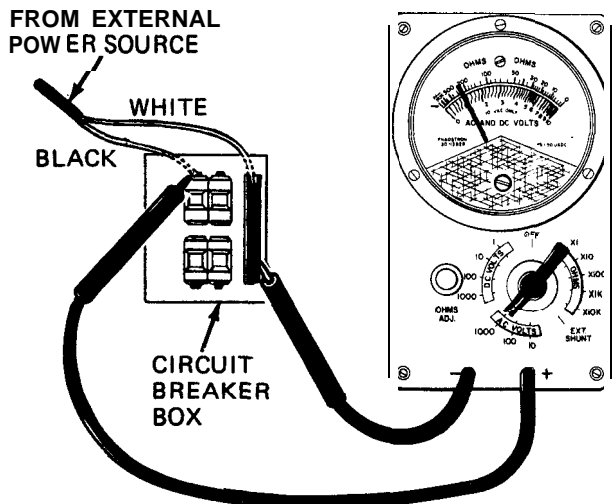

NO GO

TA 114523

Figure 25-42 (Sheet 3 of 6)

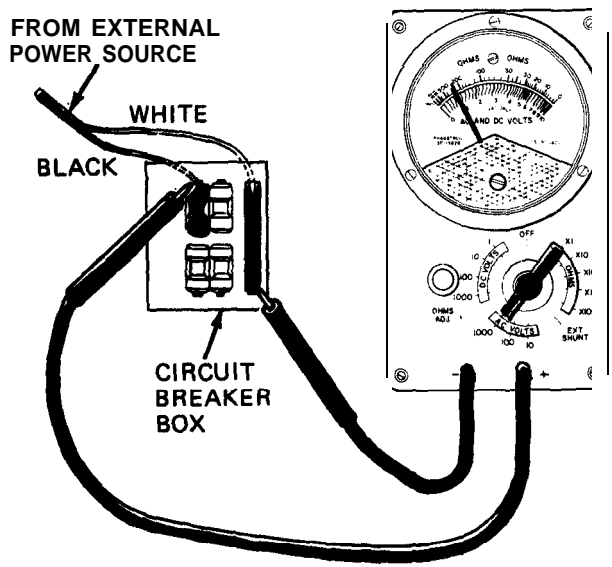

NO GO

7

If multimeter measured zero volts check incoming power source for 115 volts AC

- Put multimeter - lead on terminal strip
- Put multimeter + lead on black wire lead
- Read multimeter. Multimeter should measure 115 volts AC

Does multimeter measure 115 volts AC?

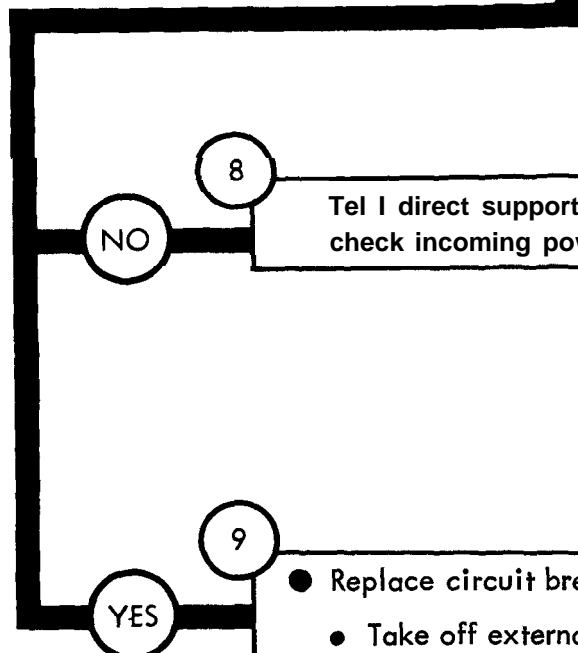

8

Tel I direct support maintenance to check incoming power source

9

- Replace circuit breaker
- Take off external power source from trailer
- Replace circuit breaker. Refer to Vol 3, chapter 18, para 18-70

Figure 25-42 (Sheet 4 of 6)

From step 6

10

- Clean and test circuit breaker for continuity
 - Take off **external** power source to van. Refer to TM 9-2320-209-10
 - Clean front and rear terminals of circuit breaker. Refer to Vol 3, chapter 18, para 18-70
 - Set **multimeter** to measure continuity. Refer to test equipment procedures index
 - Set circuit breaker to ON

- Put **multimeter** + lead on front terminal of circuit breaker
- Put **multimeter** - lead on rear terminal of circuit breaker
- Read **multimeter**. Multi meter should measure zero ohms

Does **multimeter** measure zero ohms?

GO

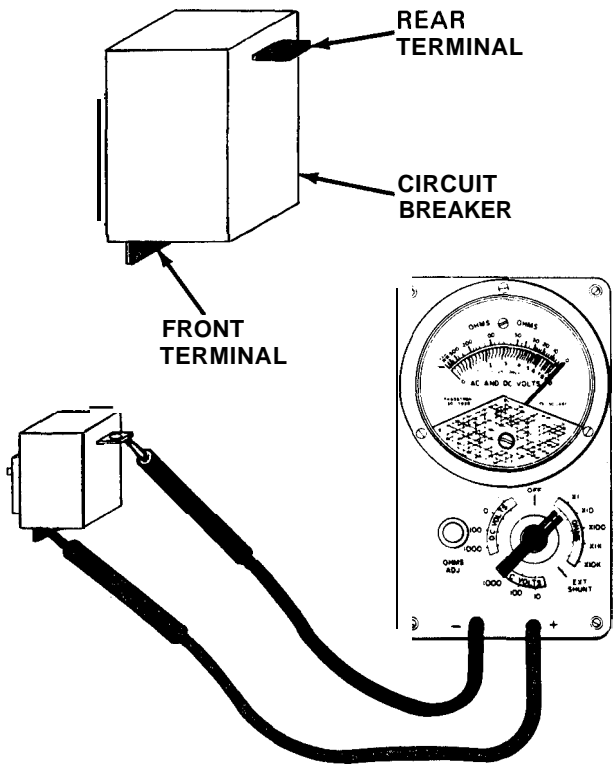

Figure 25-42 (Sheet 5 of 6)

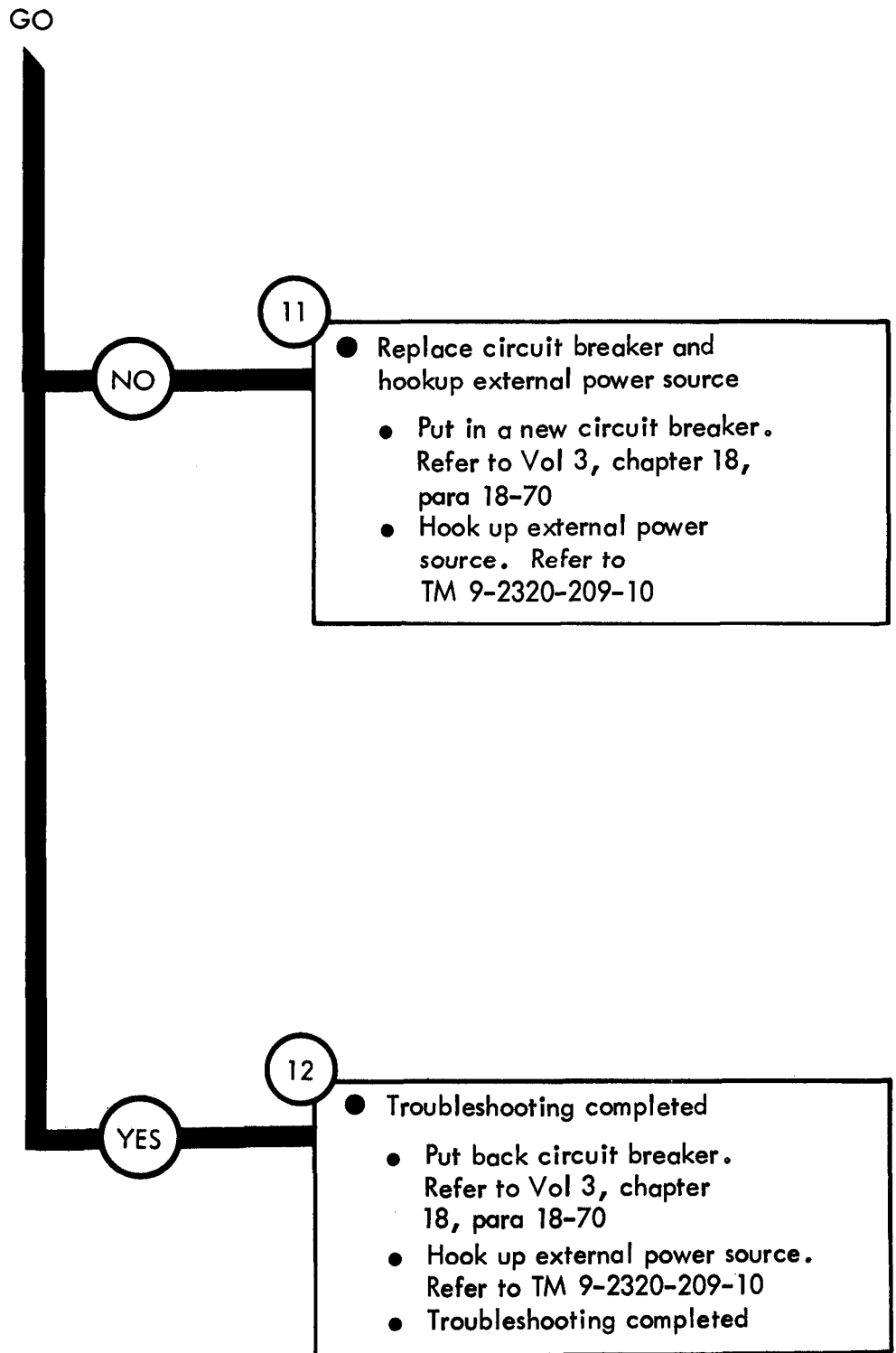

Figure 25-42 (Sheet 6 of 6)

Symptom

43

NO POWER AVAILABLE WHEN CIRCUIT BREAKER IS TURNED ON

WARNING
 Only properly trained personnel should perform test on 115 volt AC systems
 The voltage present in 115 volt system cause severe or fatal electric shock

1

- Park truck
 - Refer to TM 9-2320-209-10

2

- Check for 115 volts AC at circuit breaker
 - Set circuit breaker to ON
 - Set multimeter to measure 115 volts AC. Refer to test equipment procedures index
 - Put multimeter - lead on terminal strip
 - Put multimeter + lead on front bottom terminal of circuit breaker
 - Read multimeter. Multimeter should measure 115 volts AC

Does multimeter measure 115 volts AC?

GO

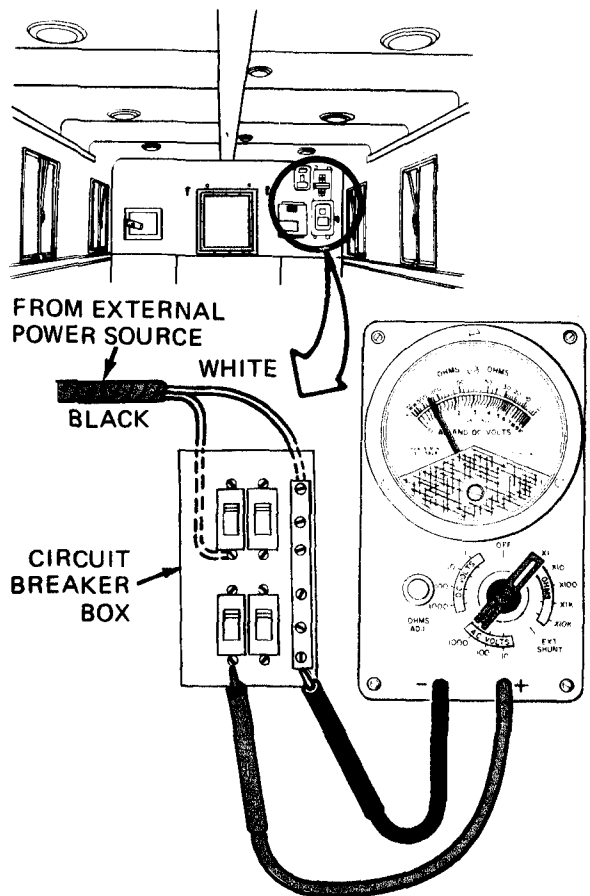

TA 114527

Figure 25-43 (Sheet 1 of 4)

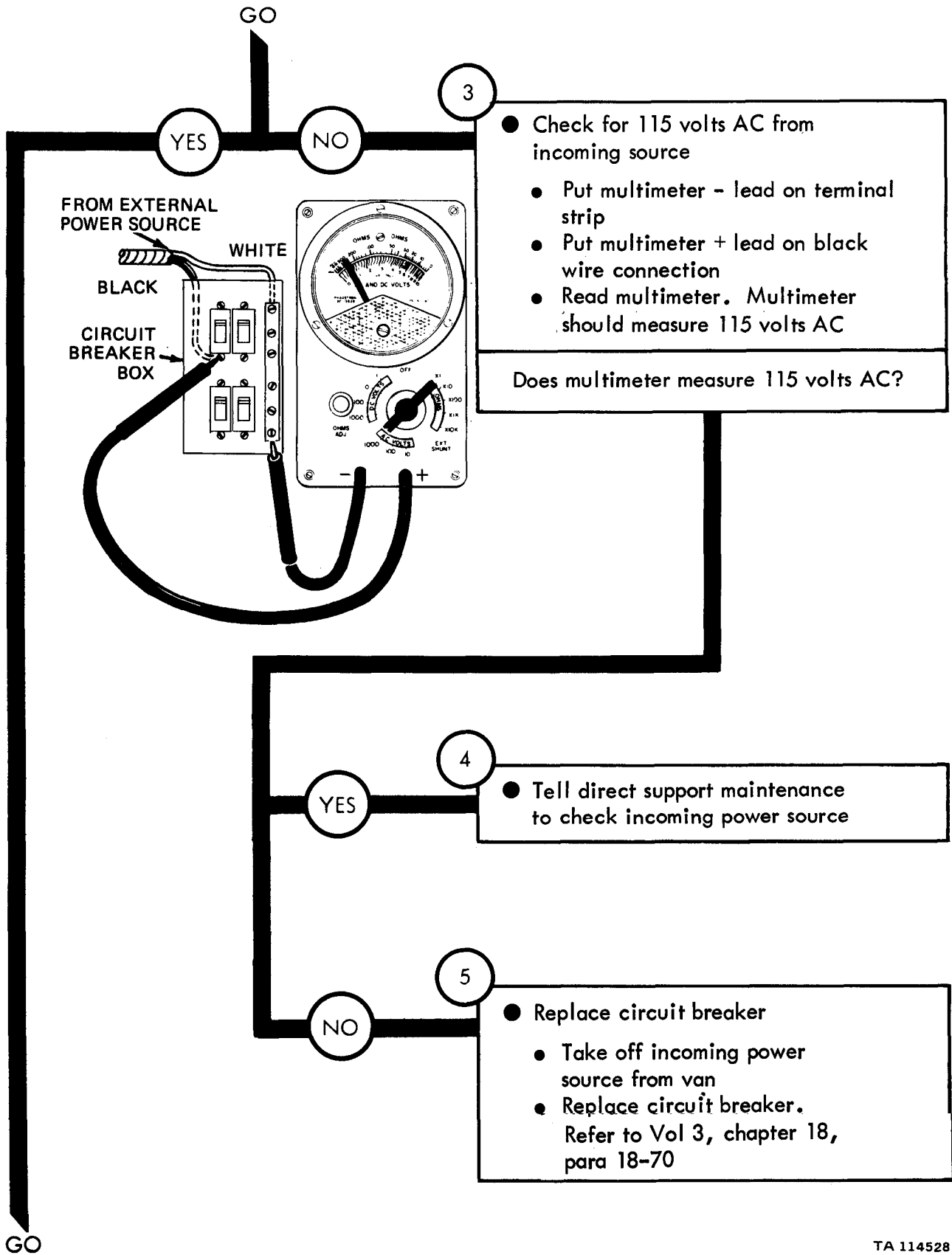

TA 114528

Figure 25-43 (Sheet 2 of 4)

GO

6

- Clean and check circuit breaker for continuity
 - Take off power source to van
 - Take off circuit breaker from circuit breaker box. Refer to Vol 3, chapter 18, para 18-70
 - Clean front and rear terminals of circuit breaker. Refer to Vol 3, chapter 18, para 18-70
 - Set circuit breaker to ON

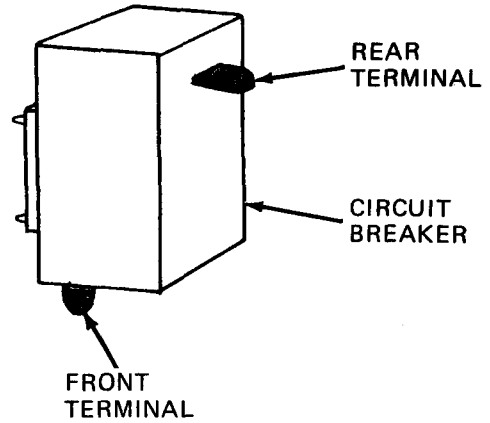

- Set multimeter to measure continuity. Refer to test equipment procedures index
- Put multimeter - lead on rear terminal of circuit breaker
- Put multimeter + lead on front terminal of circuit breaker
- Read multimeter. Multimeter should measure zero ohms

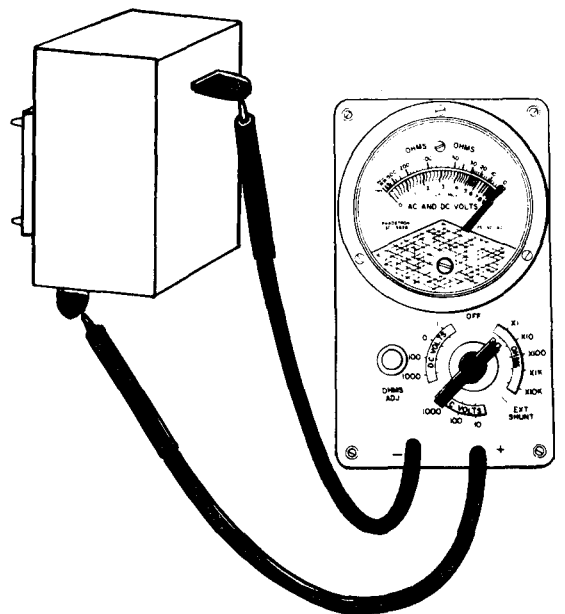

Does multimeter measure more than zero ohms?

GO

Figure 25-43 (Sheet 3 of 4)

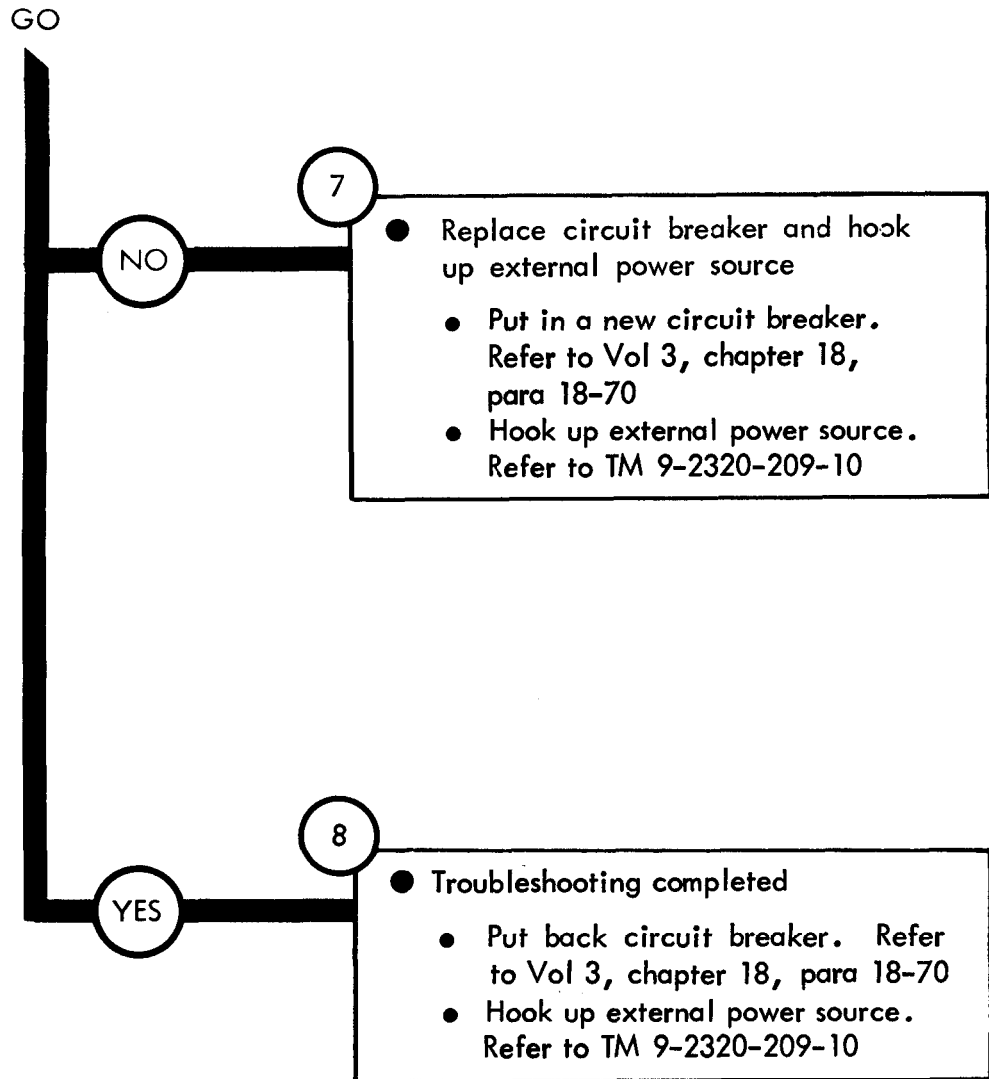

Figure 25-43 (Sheet 4 of 4)

Symptom

44

115 VOLTS AC VENTILATOR BLOWER DOES NOT WORK

WARNING

Only properly trained personnel should perform test on 115 volt system

The voltage present in 115 volt system can cause severe or fatal electric shock

1

- Park truck
- Refer to TM-9-2320-209-10

GO

Figure 25-44 (Sheet 1 of 5)

2 **GO**

- Check circuit to ventilator blower
 - Set circuit breaker to OFF
 - Take off two leads from blower
 - Set circuit breaker to ON

- Set multimeter to measure 115 volts AC. Refer to test equipment procedures index
- Put multimeter - lead on one blower lead
- Put multimeter + lead on other blower lead
- Read multimeter. Multimeter should measure 115 volts AC

Does multimeter measure 115 volts AC?

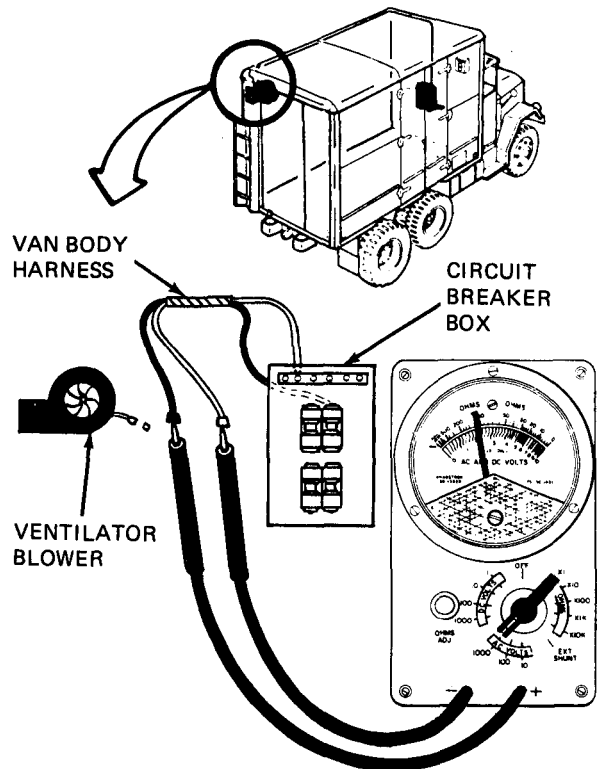

YES **NO**

4

- Go to step 11

3

- Check for 115 volts AC at circuit breaker
 - Set circuit breaker on ON
 - Put multimeter - lead on terminal strip
 - Put multimeter + lead on front bottom terminal of circuit breaker
 - Read multimeter. Multimeter should measure 115 volts AC

Does multimeter measure 115 volts AC?

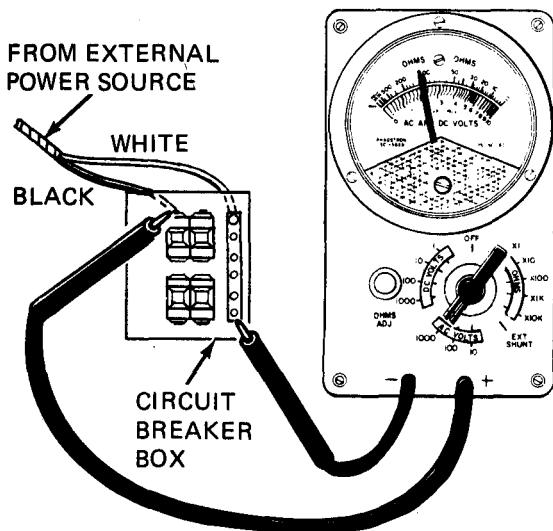

NO GO

TA 114532

Figure 25-44 (Sheet 2 of 5)

NO GO

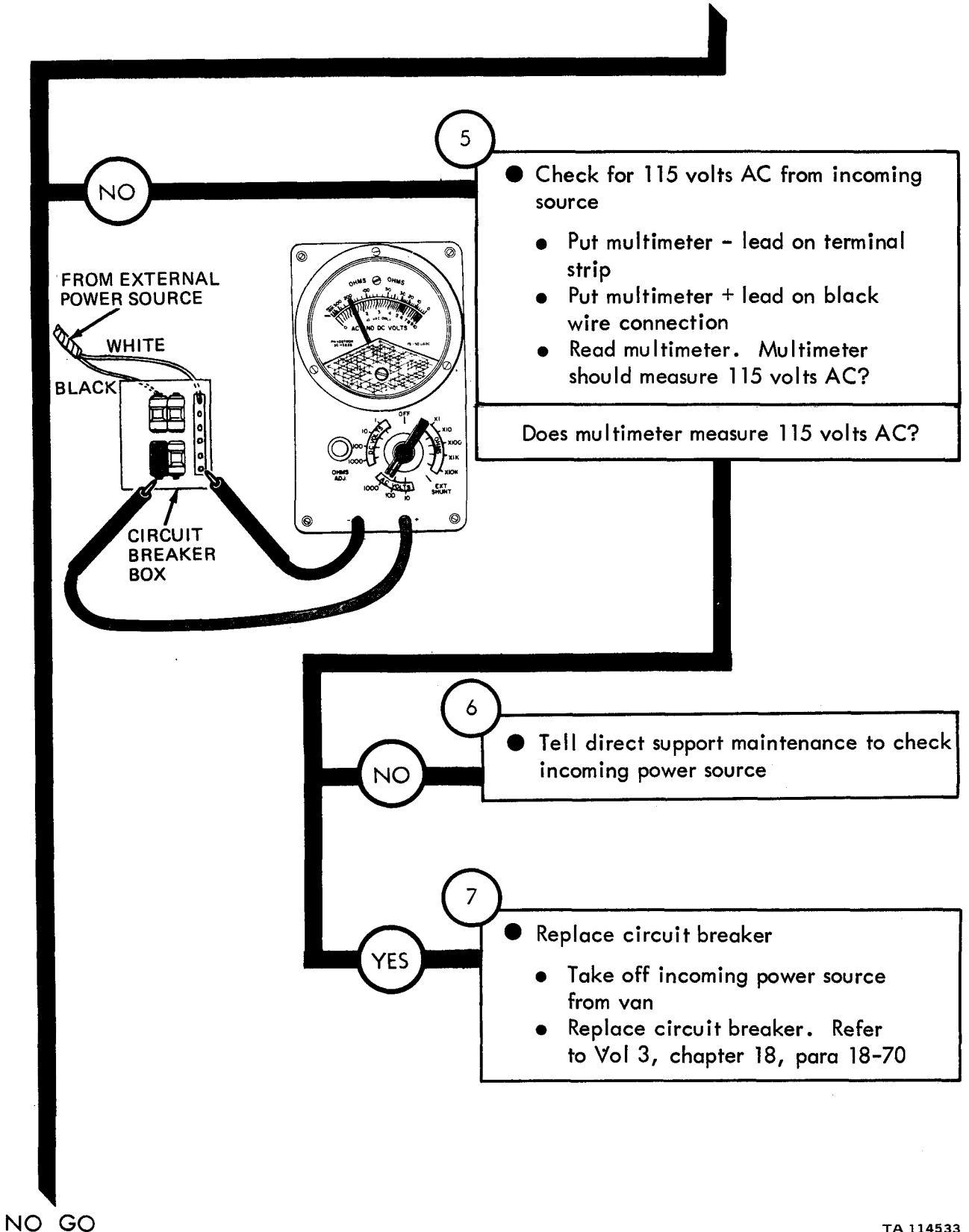

- Check for 115 volts AC from incoming source
- Put multimeter - lead on terminal strip
- Put multimeter + lead on black wire connection
- Read multimeter. Multimeter should measure 115 volts AC?

Does multimeter measure 115 volts AC?

- Tell direct support maintenance to check incoming power source

- Replace circuit breaker
- Take off incoming power source from van
- Replace circuit breaker. Refer to Vol 3, chapter 18, para 18-70

NO GO

Figure 25-44 (Sheet 3 of 5)

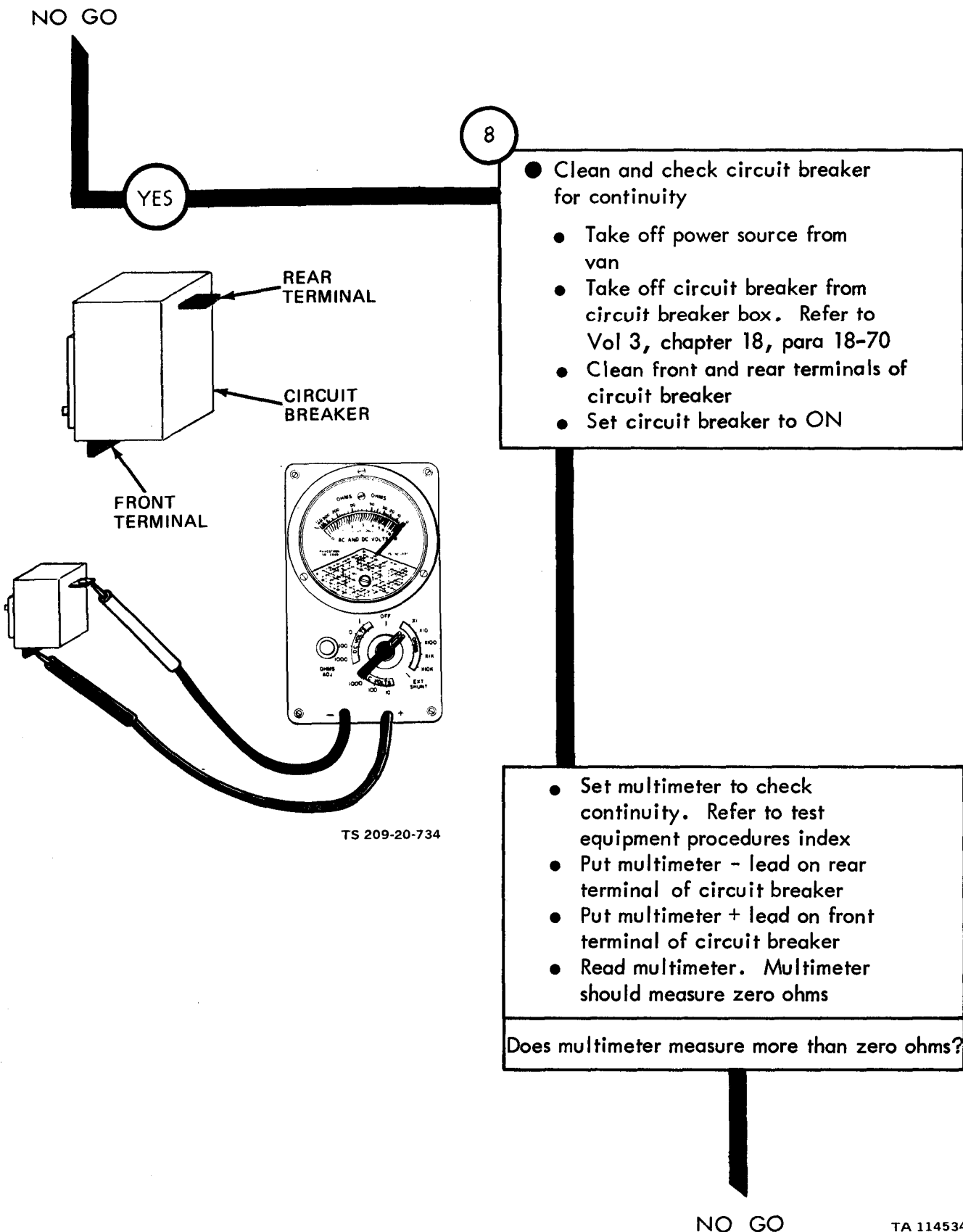
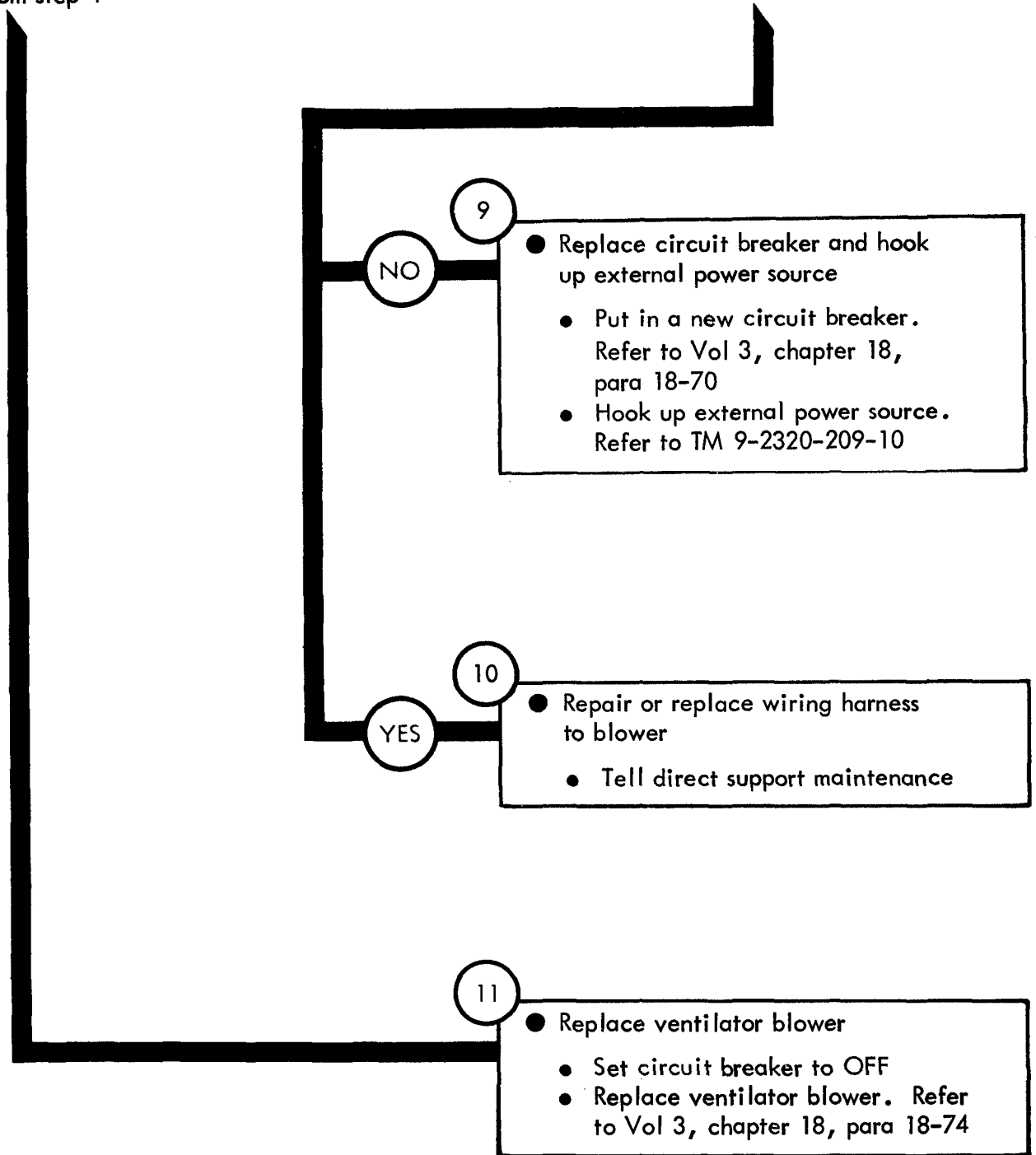

Figure 25-44 (Sheet 4 of 5)

From step 4

NO GO



TA 114535

Figure 25-44 (Sheet 5 of 5)

Symptom

45 HOT WATER PERSONNEL HEATER DEFROSTER OPERATES IN "HI" POSITION ONLY

NOTE

When measuring voltage +24 volts DC means a range of +23 to +26 volts DC

- 1
- Park truck
 - Refer to TM 9-2320-209-10

- 2
- Test heater blower system
 - Set heater switch in "LO" position
 - Set multimeter to measure +24 volts DC. Refer to test equipment procedures index
 - Put multimeter - lead on a good ground
 - Put multimeter + lead on "LO" contact on rear of switch
 - Read multimeter. Multimeter should measure +24 volts DC
- Does multimeter measure less than +24 volts DC?

GO

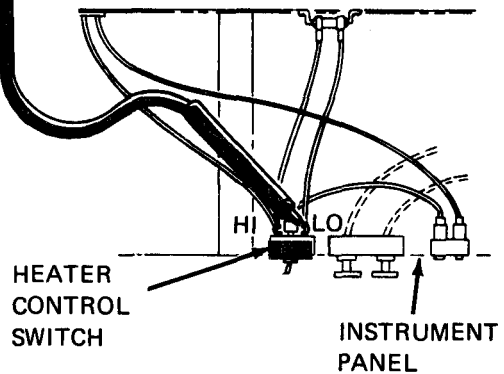
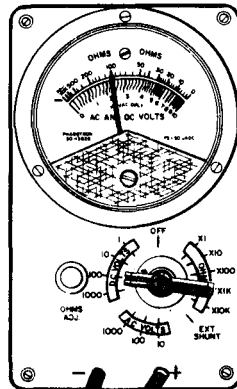
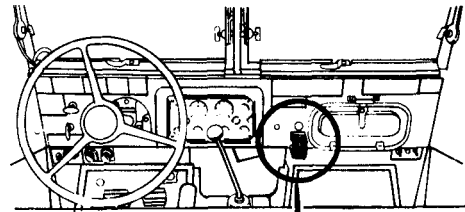

TA 114536

Figure 25-45 (Sheet 1 of 12)

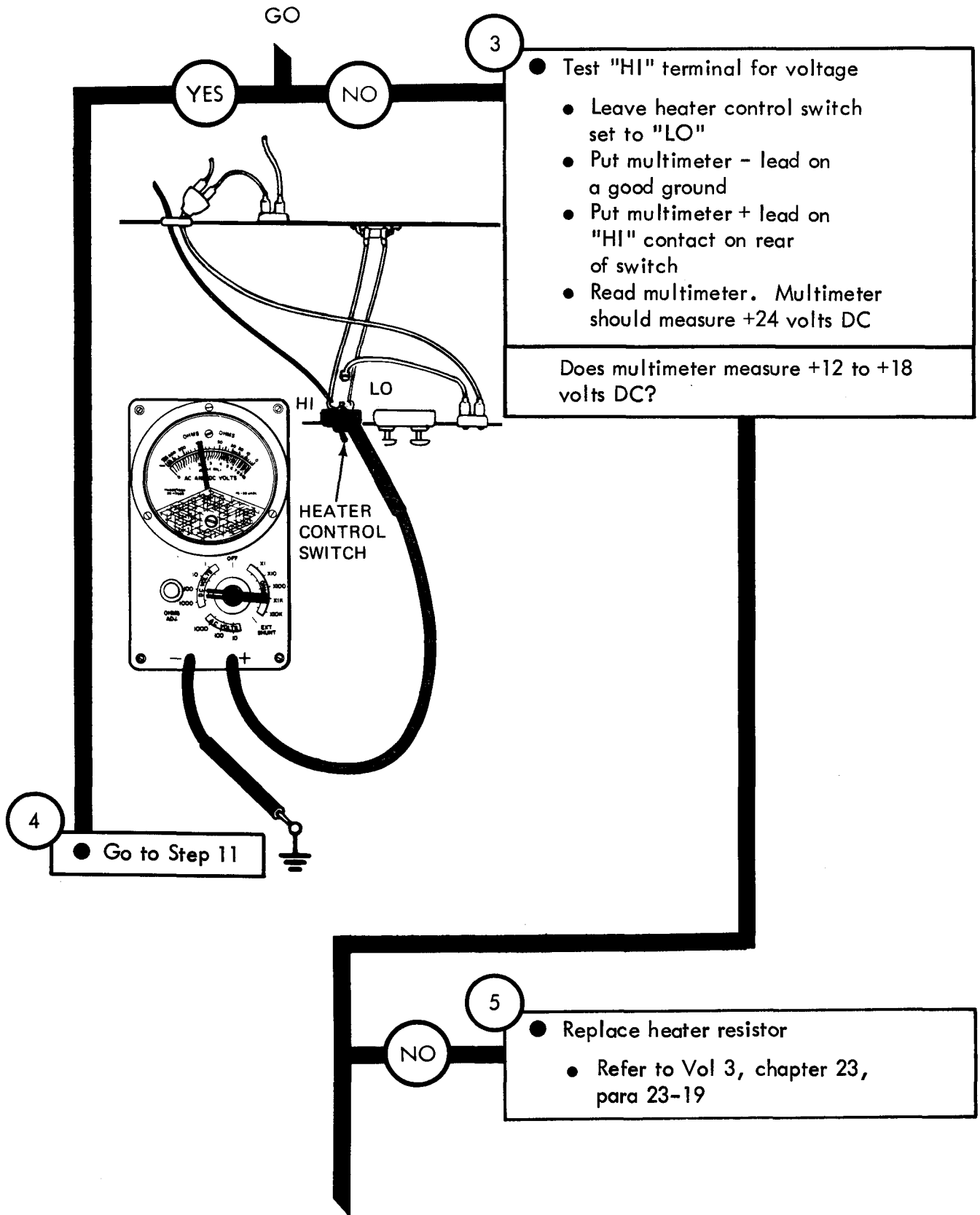

- Test "HI" terminal for voltage
 - Leave heater control switch set to "LO"
 - Put multimeter - lead on a good ground
 - Put multimeter + lead on "HI" contact on rear of switch
 - Read multimeter. Multimeter should measure +24 volts DC

Does multimeter measure +12 to +18 volts DC?

● Go to Step 11

- Replace heater resistor
 - Refer to Vol 3, chapter 23, para 23-19

NO GO

TA 114537

Figure 25-45 (Sheet 2 of 12)

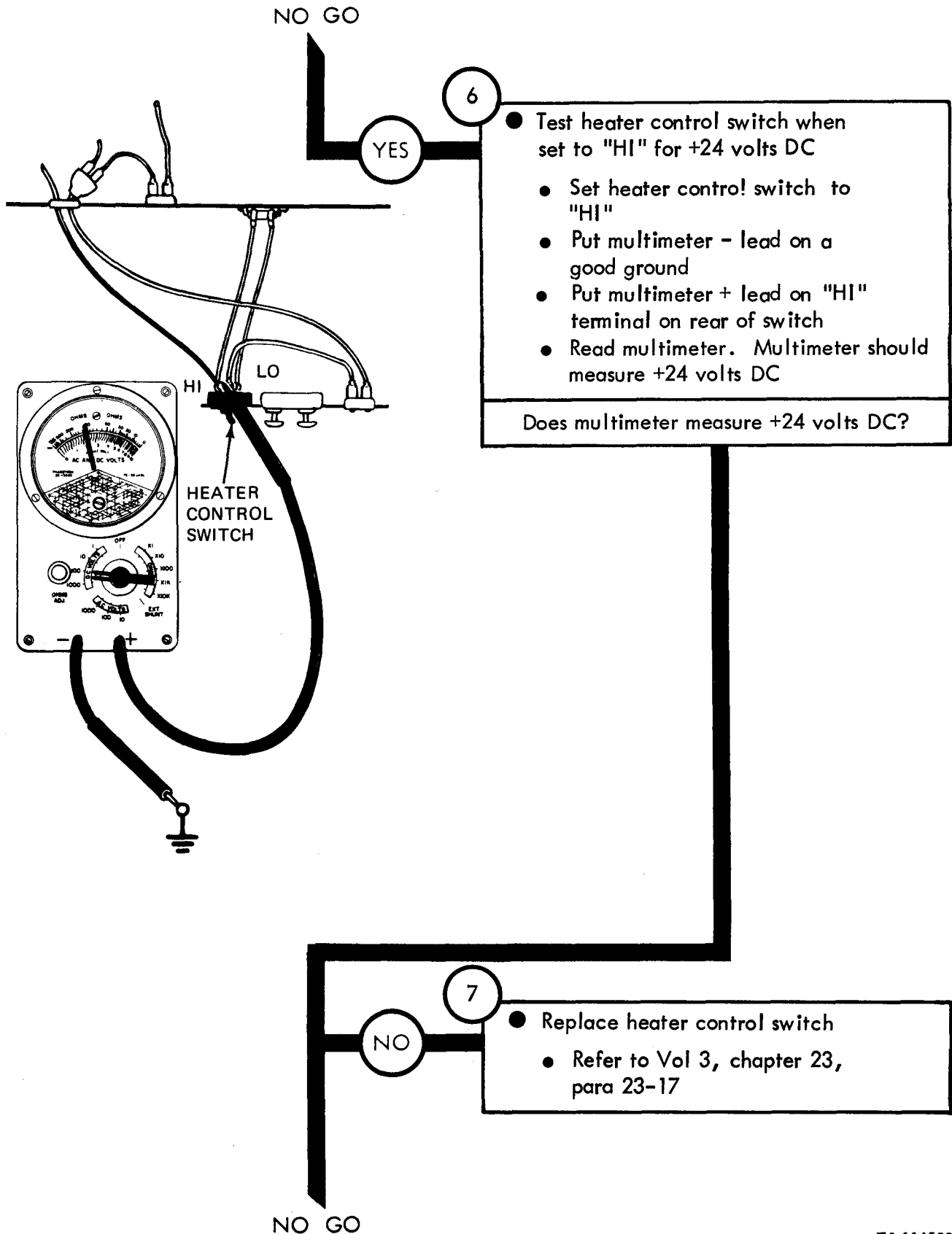
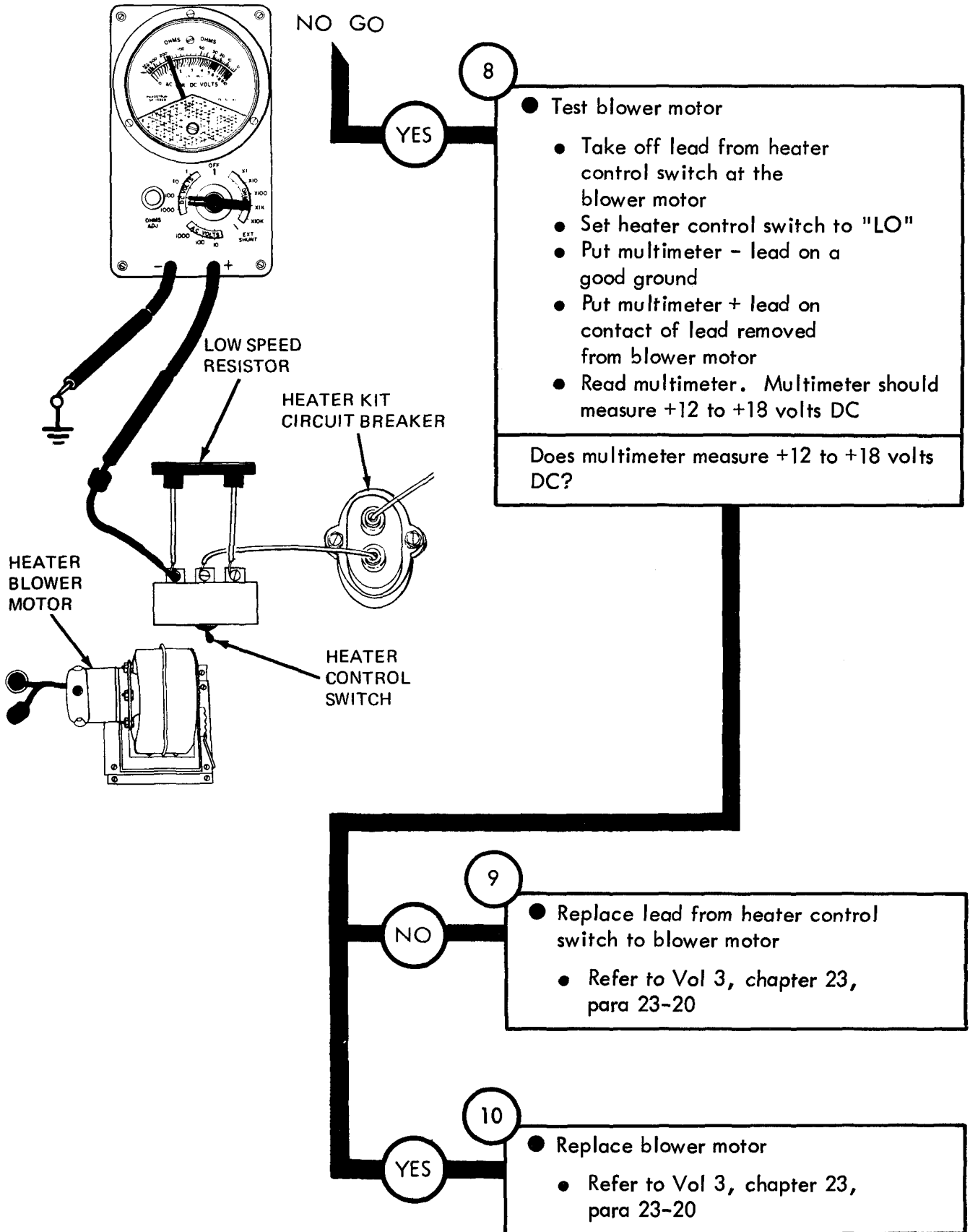

Figure 25-45 (Sheet 3 of 12)

TA 114538



TA 114539

Figure 25-45 (Sheet 4 of 12)

From step 4

11

- Check for voltage from batteries through heater control switch
 - Take off circuit breaker to control switch cable from center terminal of heater control switch
 - Put multimeter - lead on a good ground
 - Put multimeter + lead in contact of cable
 - Read multimeter. Multimeter should measure +24 volts DC

Does multimeter measure +24 volts DC?

GO

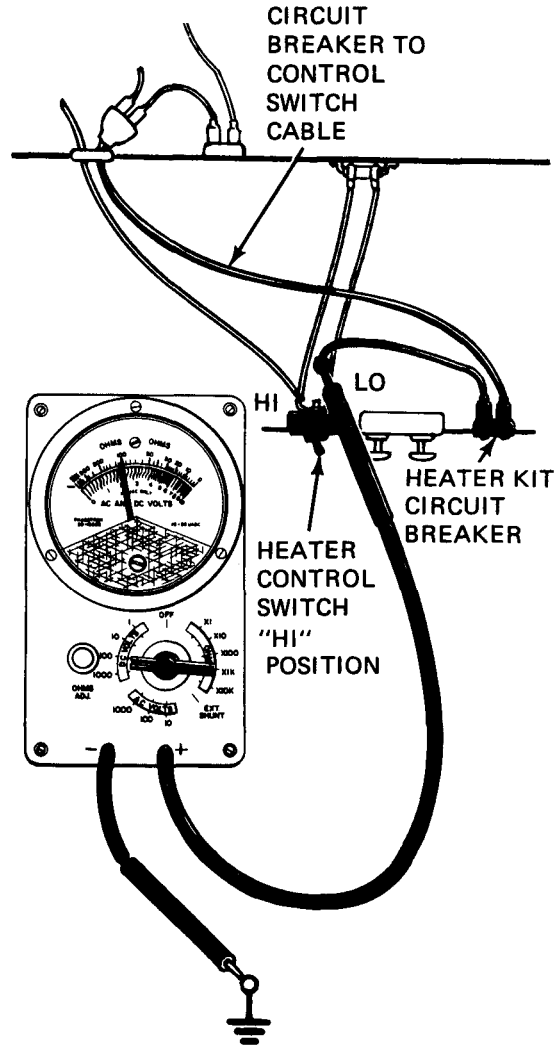
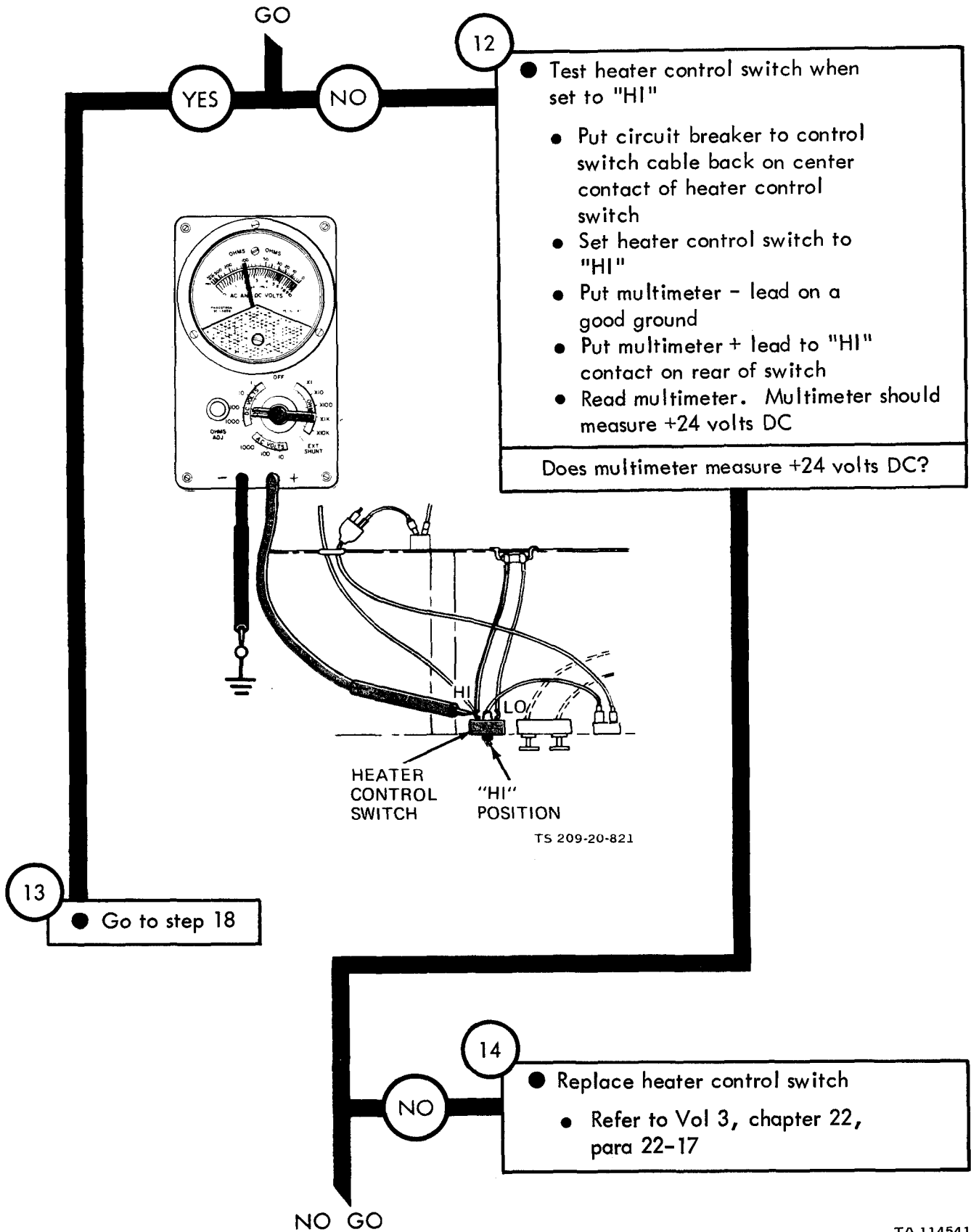
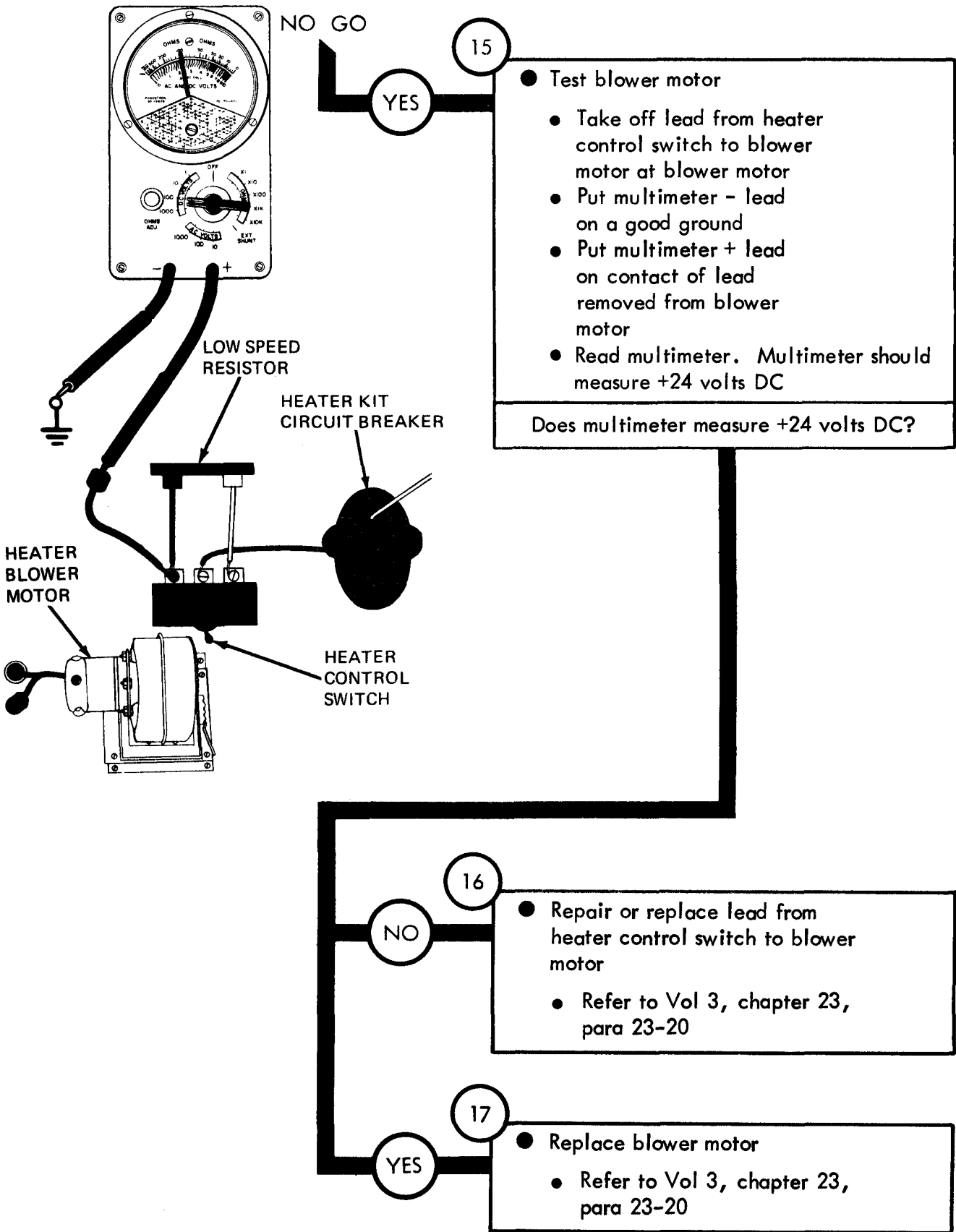

Figure 25-45 (Sheet 5 of 12)



TA 114541

Figure 25-45 (Sheet 6 of 12)



TA 114542

From step 13

18

- Check for +24 volts DC to heater kit circuit breaker
 - Put circuit breaker to control switch cable back on center contact of heater control switch
 - Take off lead from "Y" connector to heater kit circuit breaker at heater kit circuit breaker
 - Put multimeter - lead on a good ground
 - Put multimeter + lead on contact of lead to circuit breaker
 - Read multimeter. Multimeter should measure +24 volts DC
- Does multimeter measure less than +24 volts DC?

GO

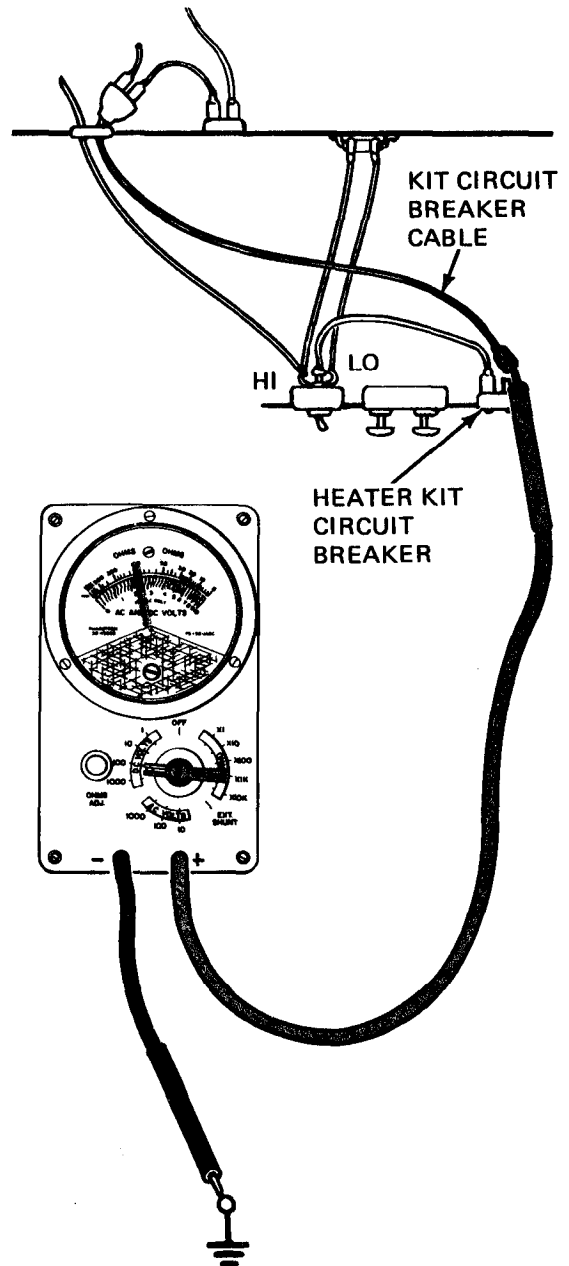
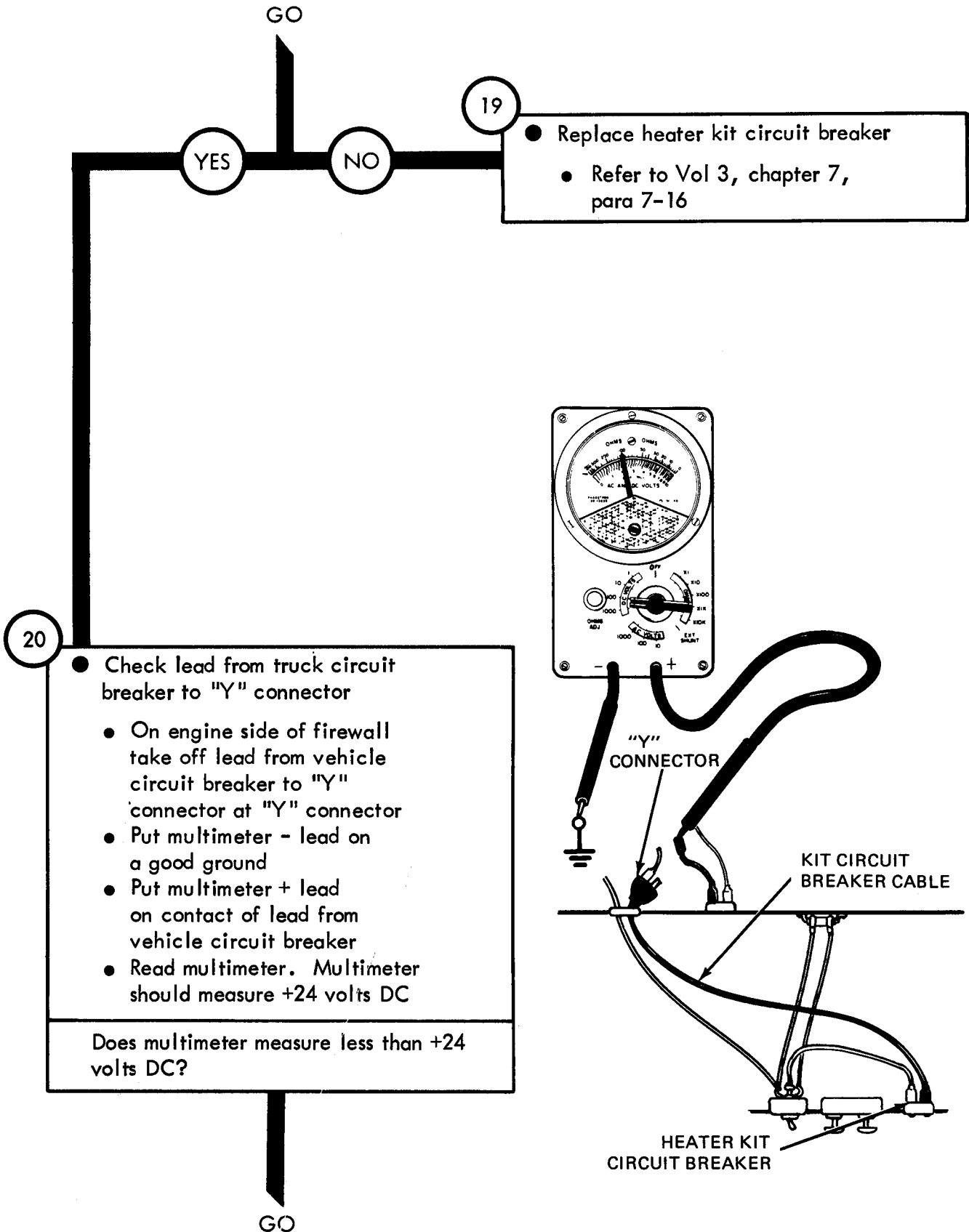
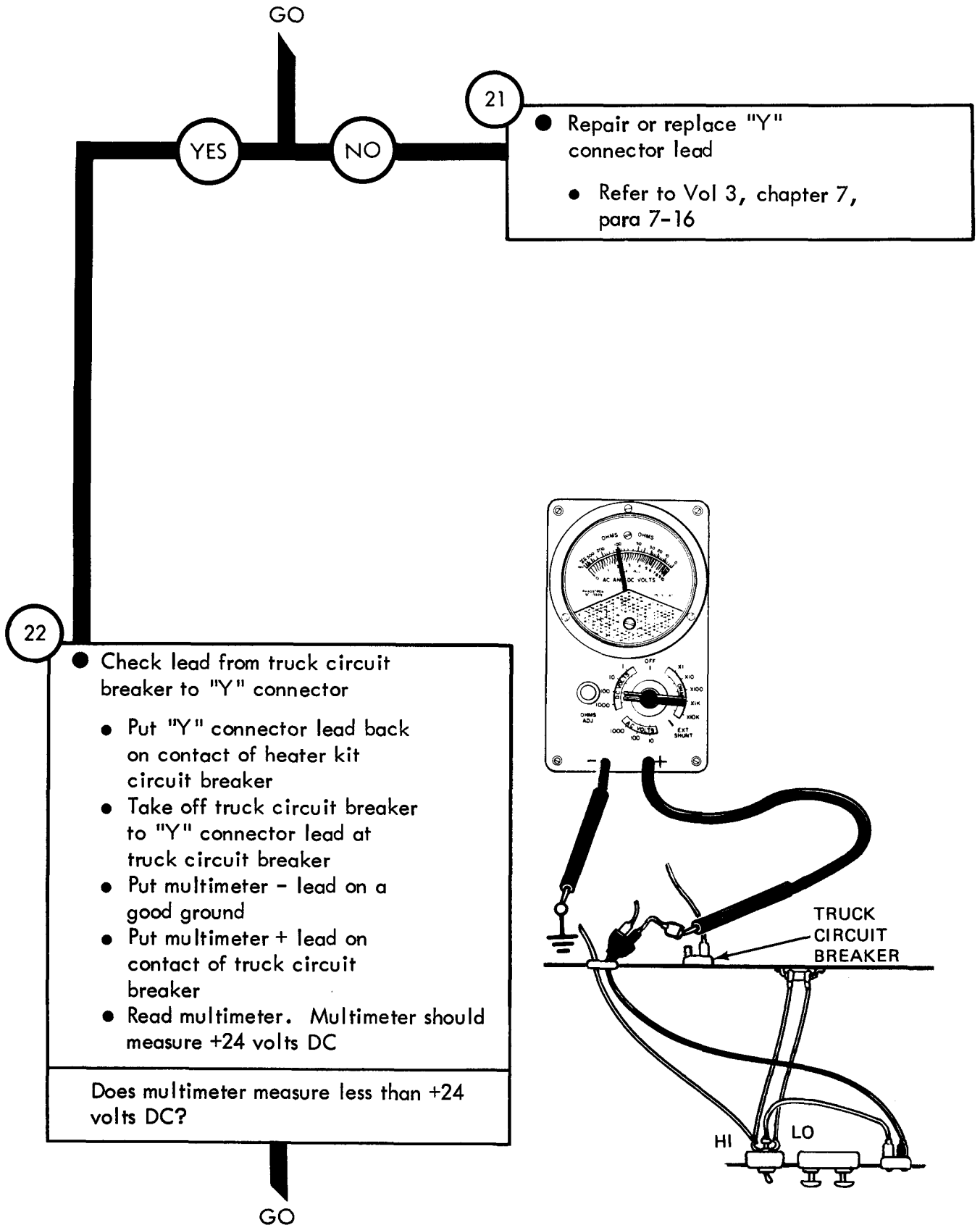

Figure 25-45 (Sheet 8 of 12)



TA 114544

Figure 25-45 (Sheet 9 of 12)



- 22
- Check lead from truck circuit breaker to "Y" connector
 - Put "Y" connector lead back on contact of heater kit circuit breaker
 - Take off truck circuit breaker to "Y" connector lead at truck circuit breaker
 - Put multimeter - lead on a good ground
 - Put multimeter + lead on contact of truck circuit breaker
 - Read multimeter. Multimeter should measure +24 volts DC
- Does multimeter measure less than +24 volts DC?

- 21
- Repair or replace "Y" connector lead
 - Refer to Vol 3, chapter 7, para 7-16

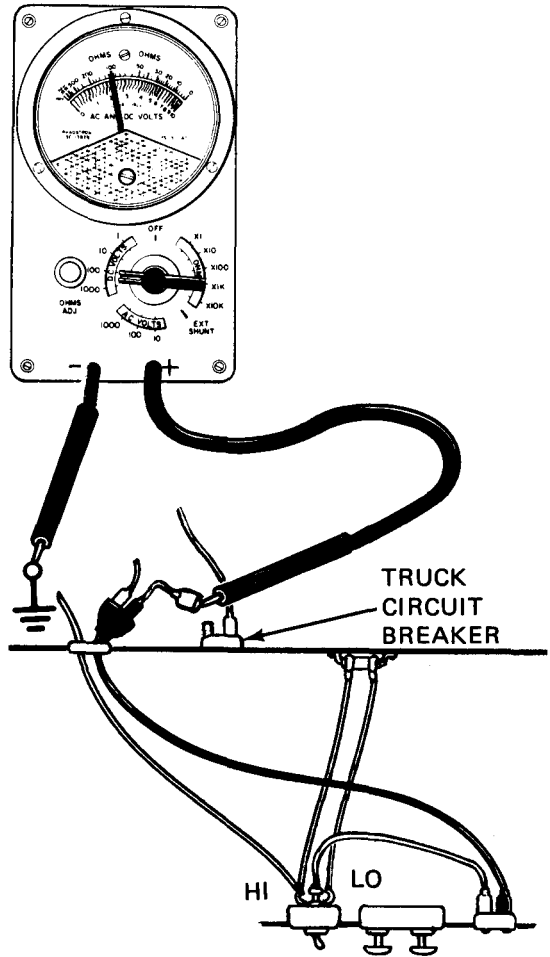
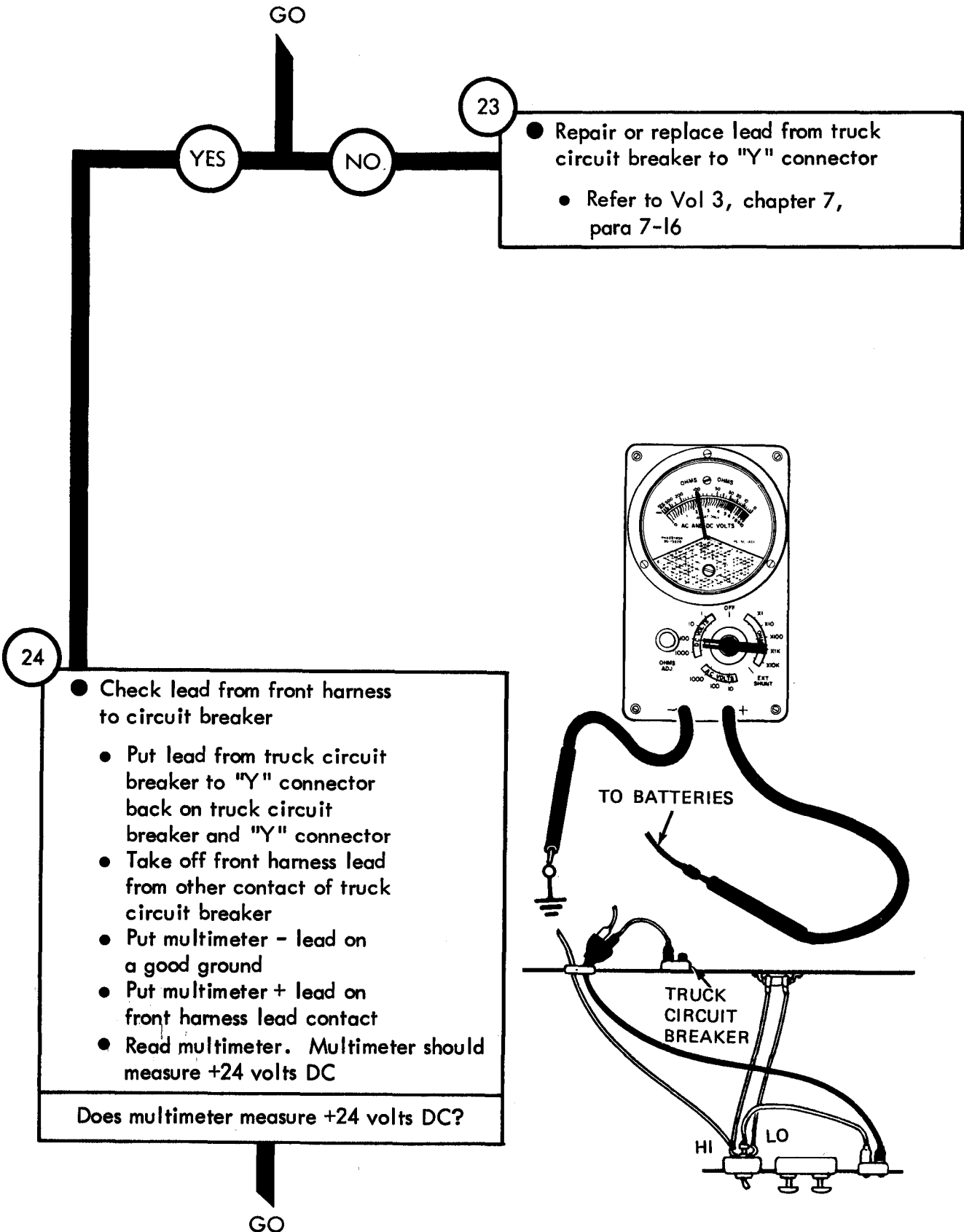
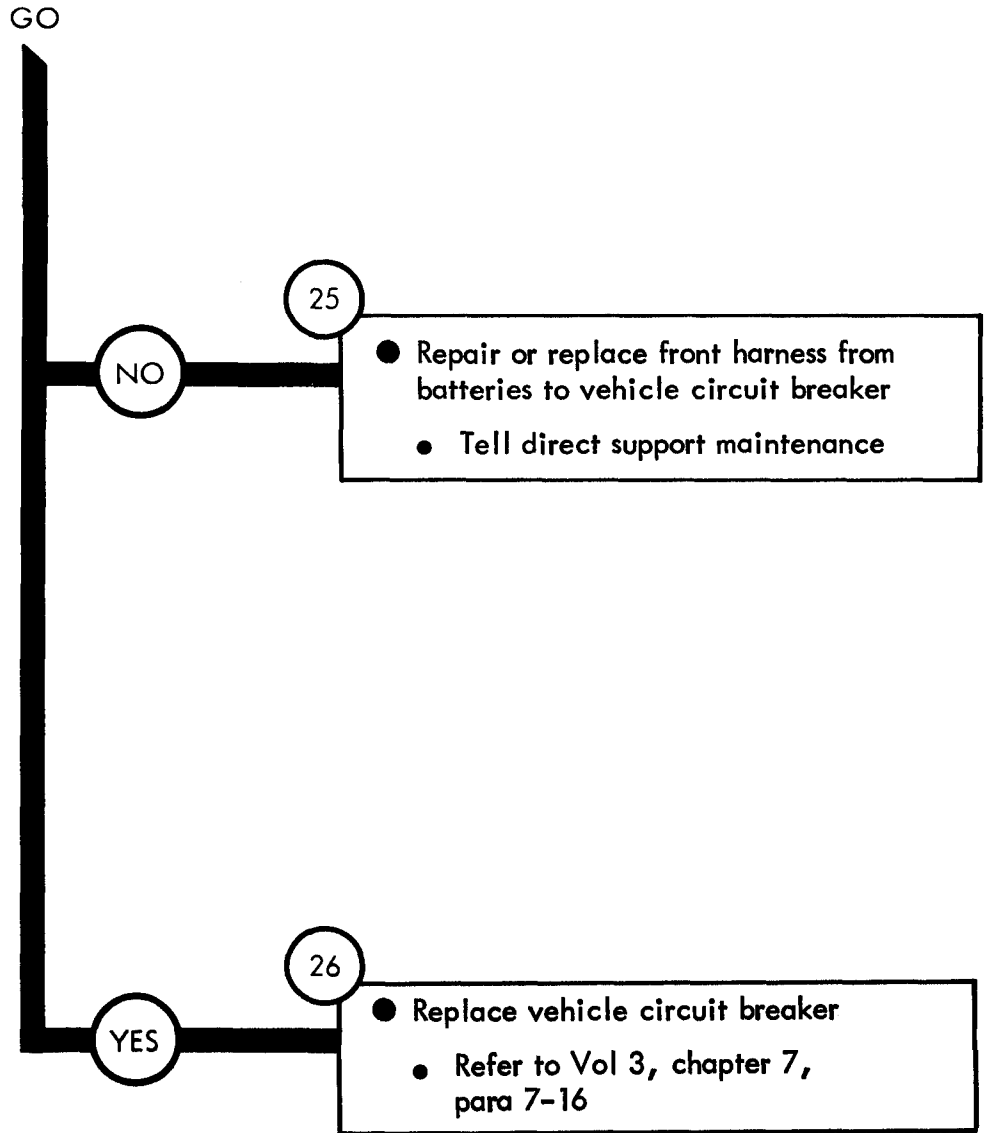

Figure 25-45 (Sheet 10 of 12)



TA 114546

Figure 25-45 (Sheet 11 of 12)



Symptom

46 HOT WATER PERSONNEL HEATER DEFROSTER OPERATES IN "LO" POSITION ONLY

NOTE

When measuring voltage +24 volts DC means a range of +23 to +26 volts DC

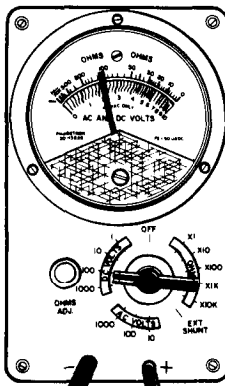
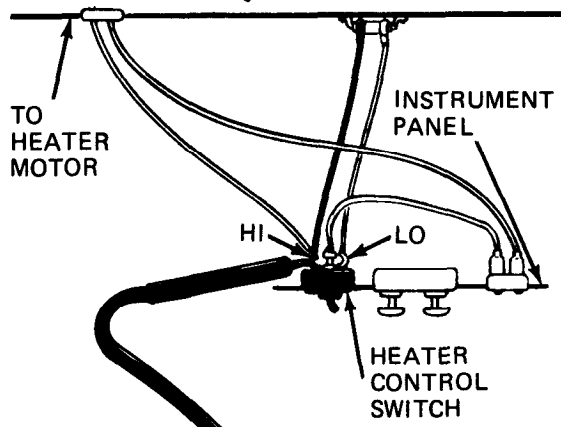
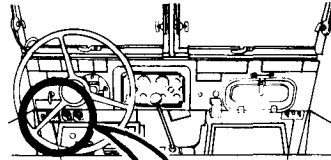

- 1
- Park truck
 - Refer to TM 9-2320-209-10

- 2
- Check for +24 volts to heater switch
 - Set heater switch to "HI"
 - Set multimeter to measure +24 volts DC. Refer to test equipment procedures index
 - Put multimeter - lead on a good ground
 - Put multimeter + lead on "HI" contact on rear of heater switch
 - Read multimeter. Multimeter should measure +24 volts DC

Does multimeter measure +24 volts DC?

GO

Figure 25-46 (Sheet 1 of 16)

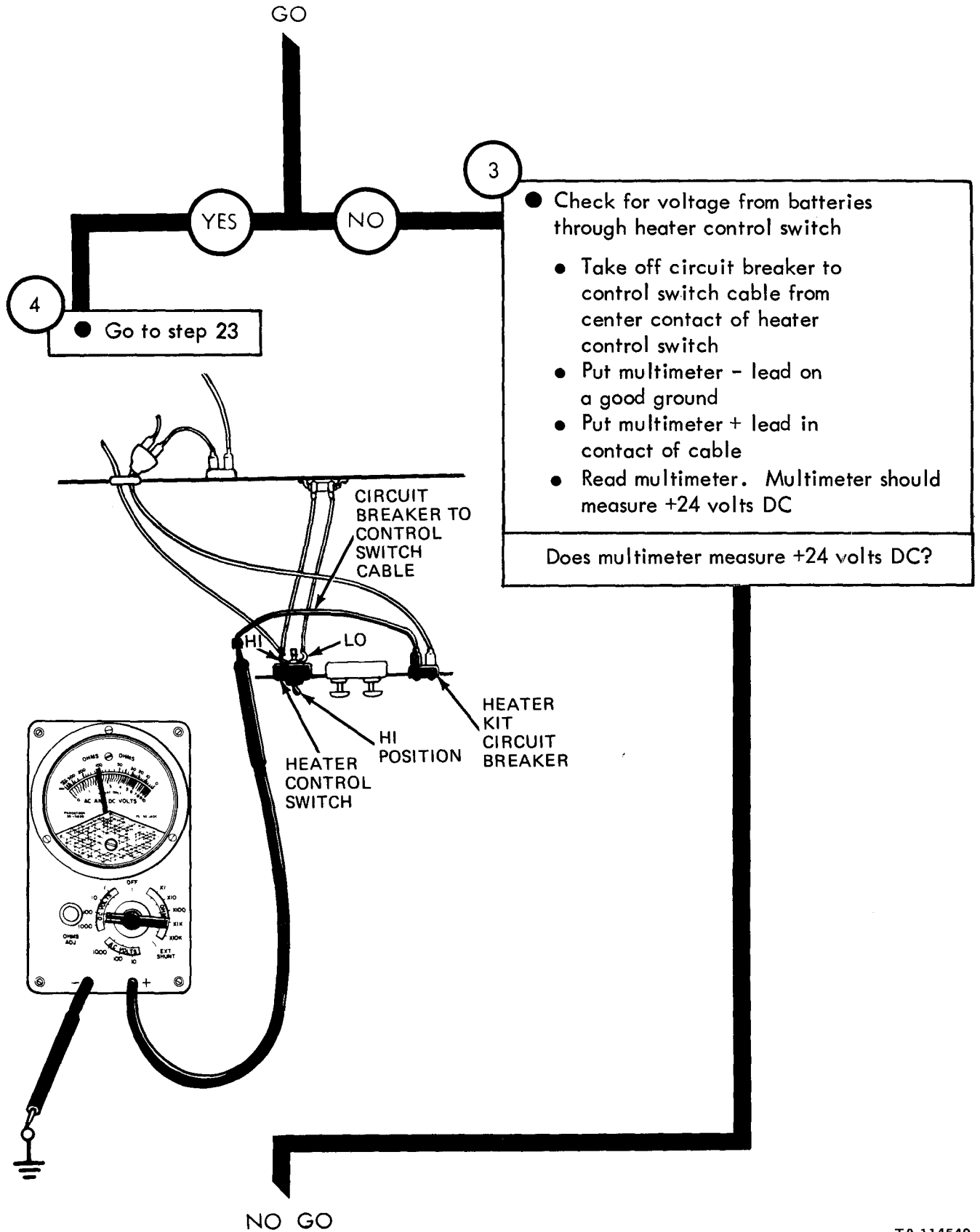

Figure 25-46 (Sheet 2 of 16)

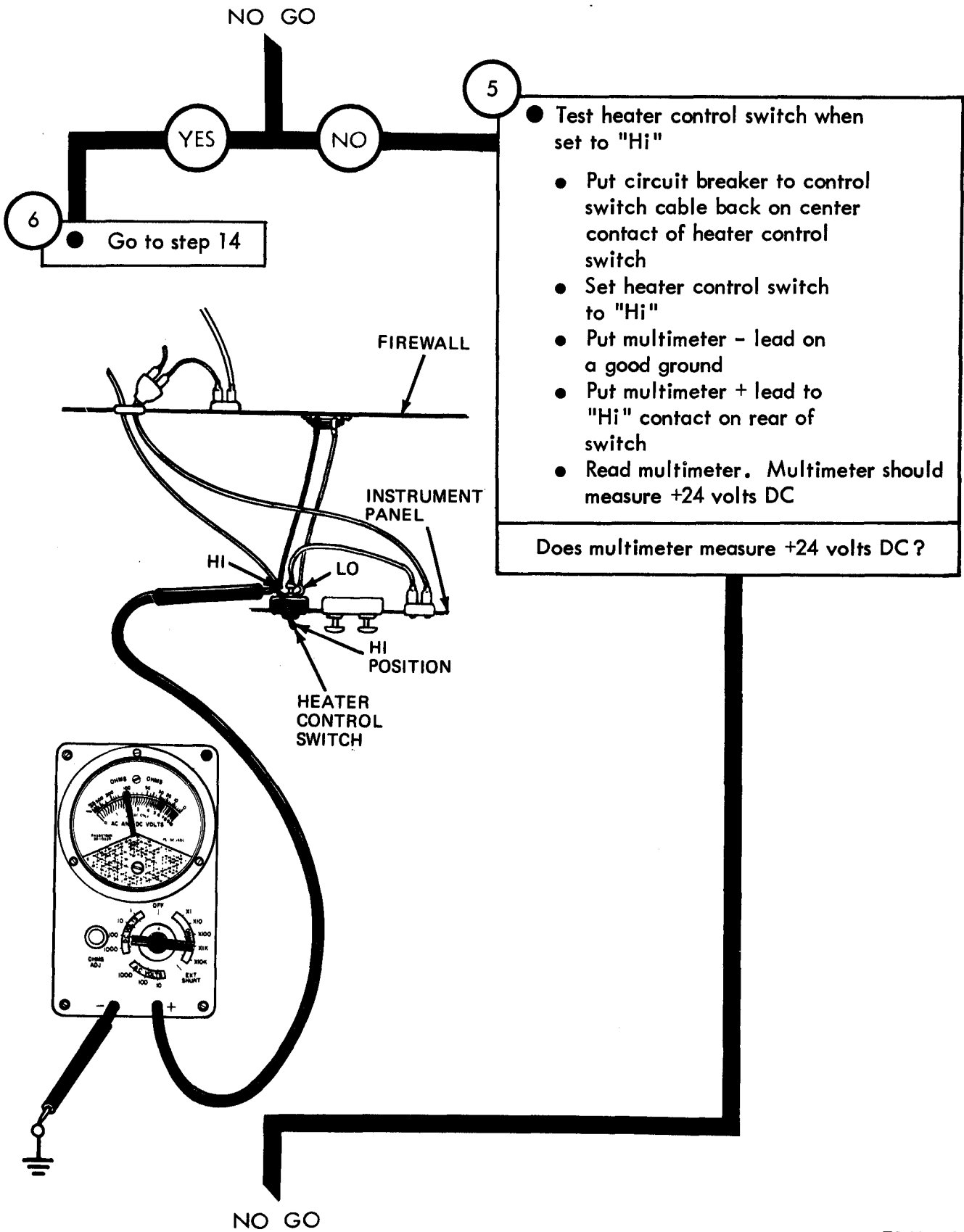
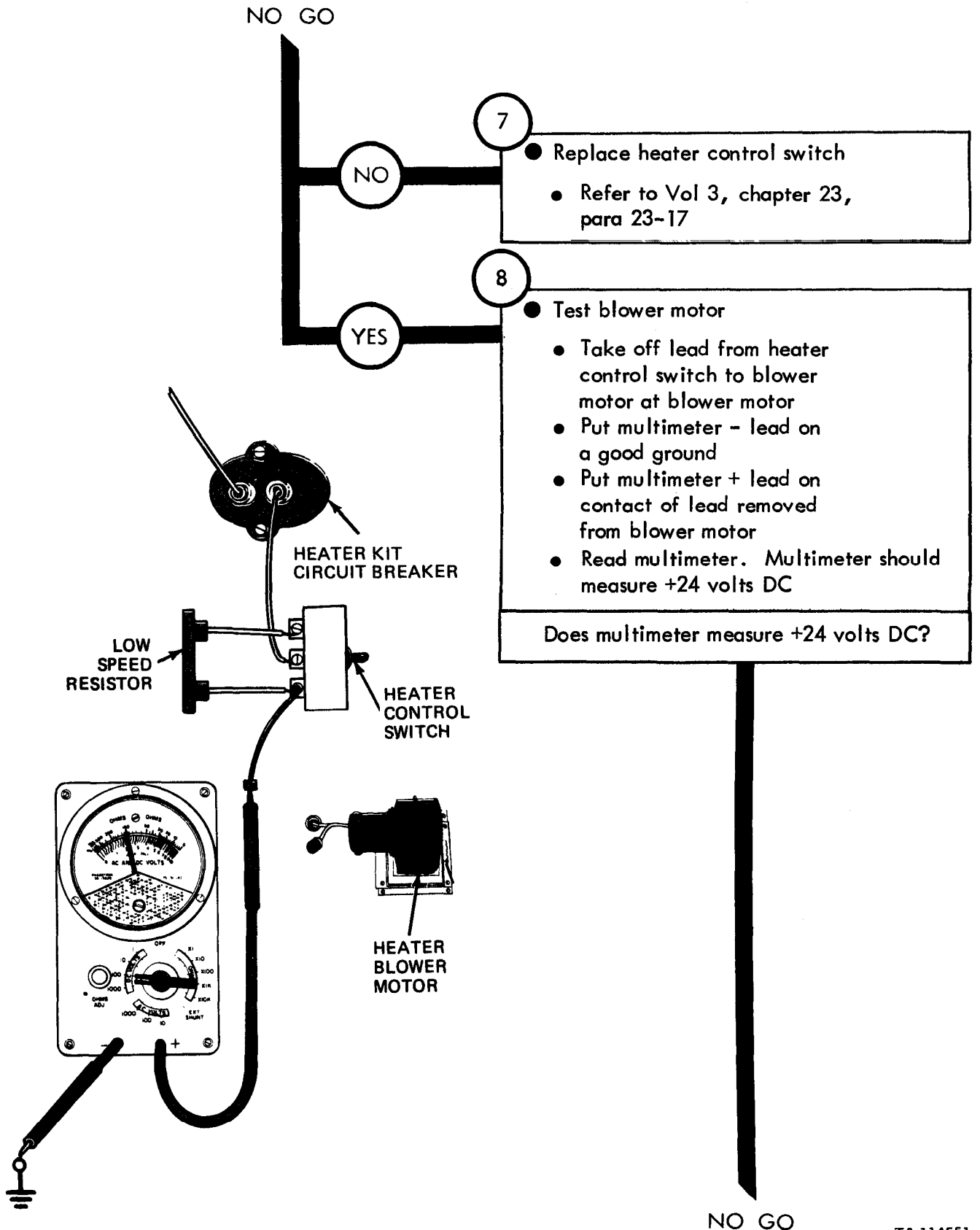

Figure 25-46 (Sheet 3 of 16)



TA 114551

Figure 25-46 (Sheet 4 of 16)

NO GO

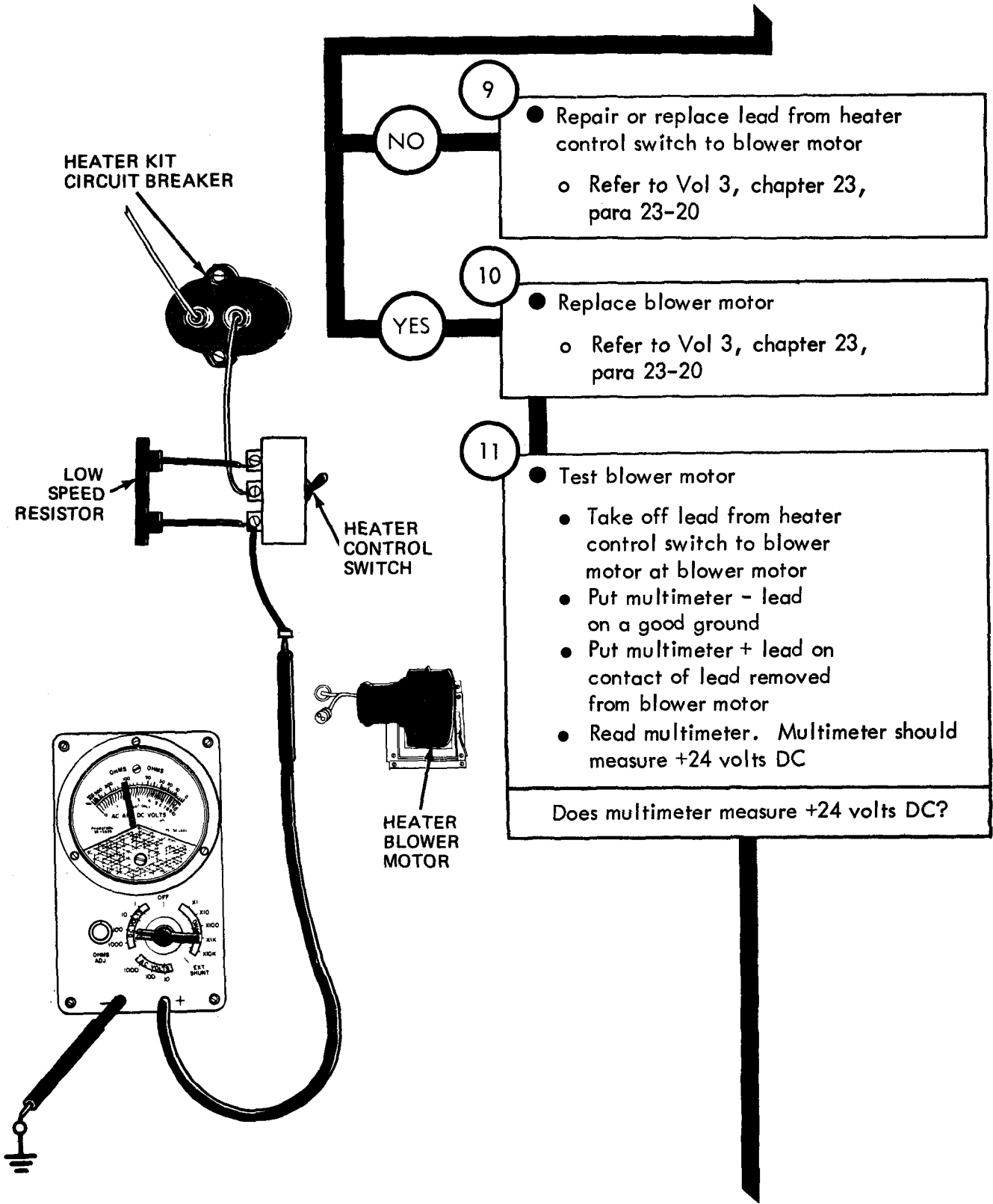

NO GO

TA 114552

Figure 25-46 (Sheet 5 of 16)

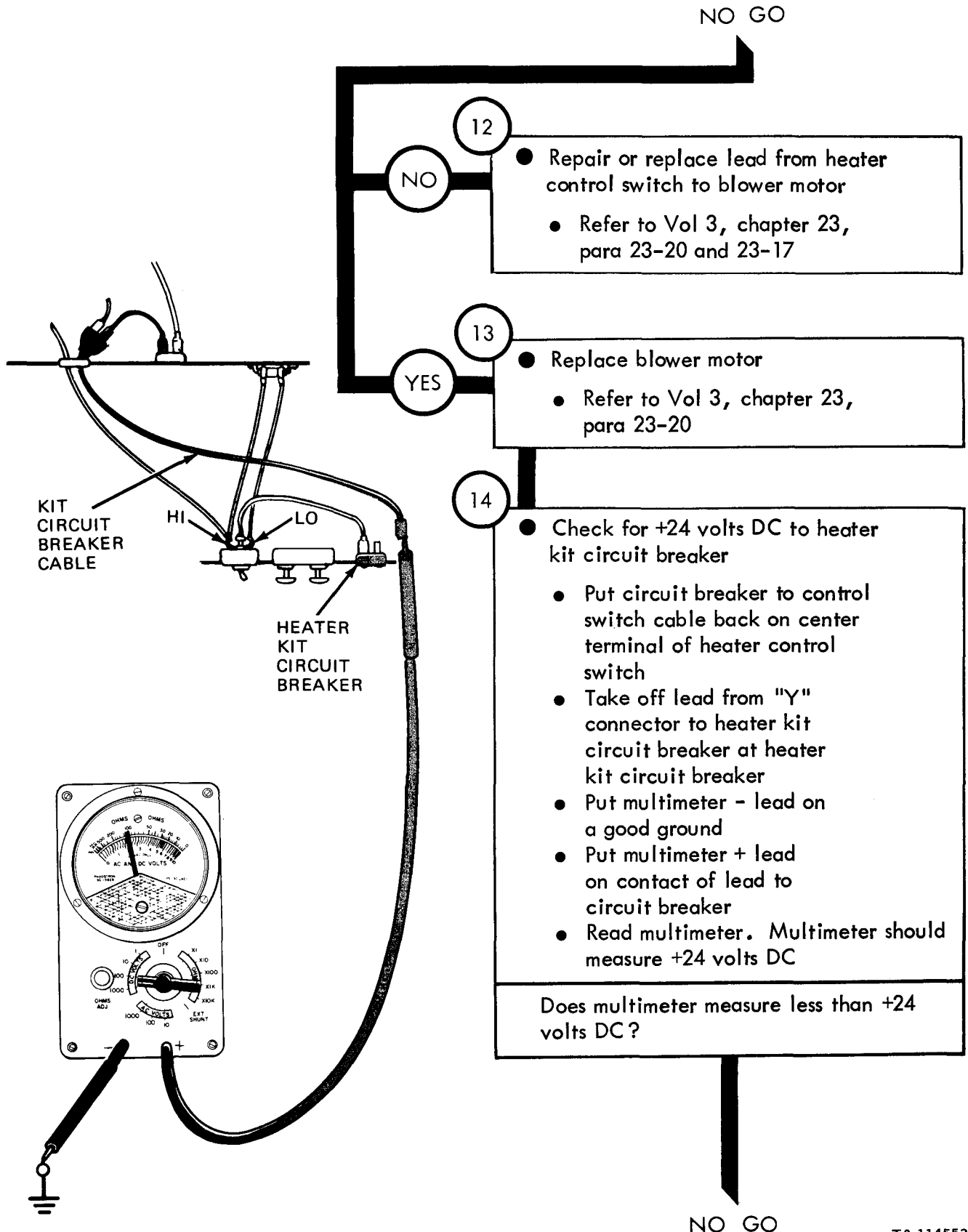

Figure 25-46 (Sheet 6 of 16)

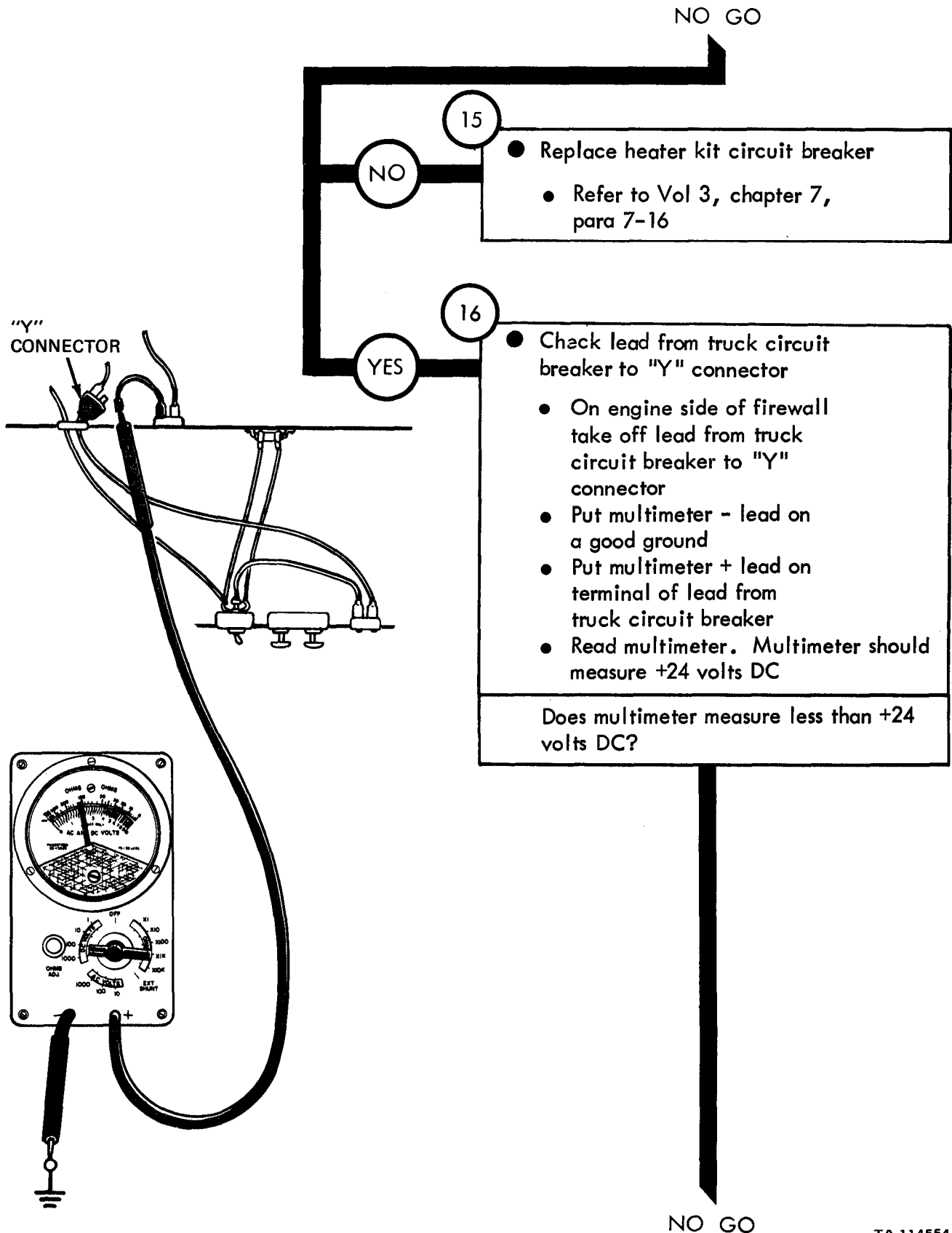

Figure 25-46 (Sheet 7 of 16)

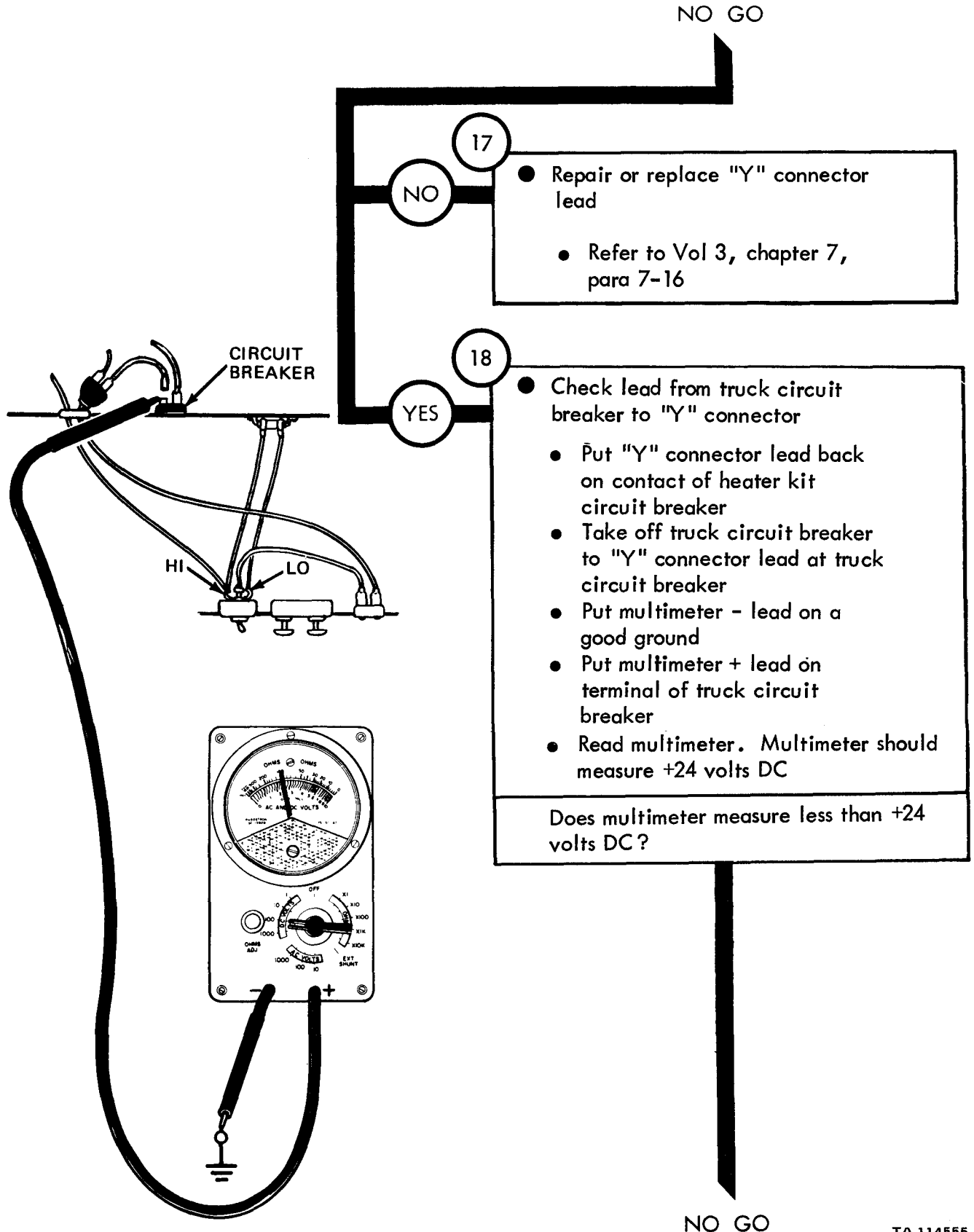
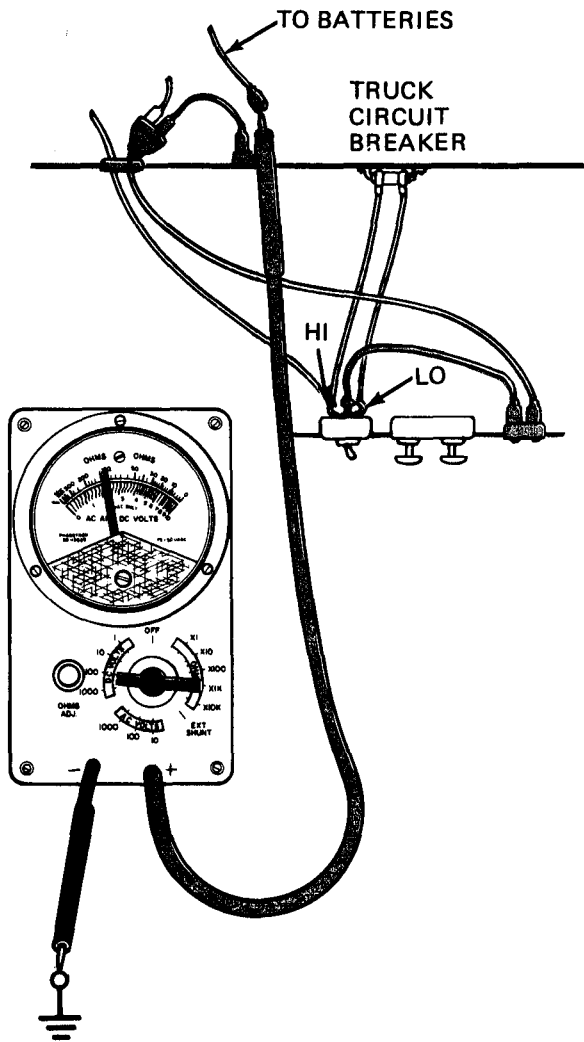
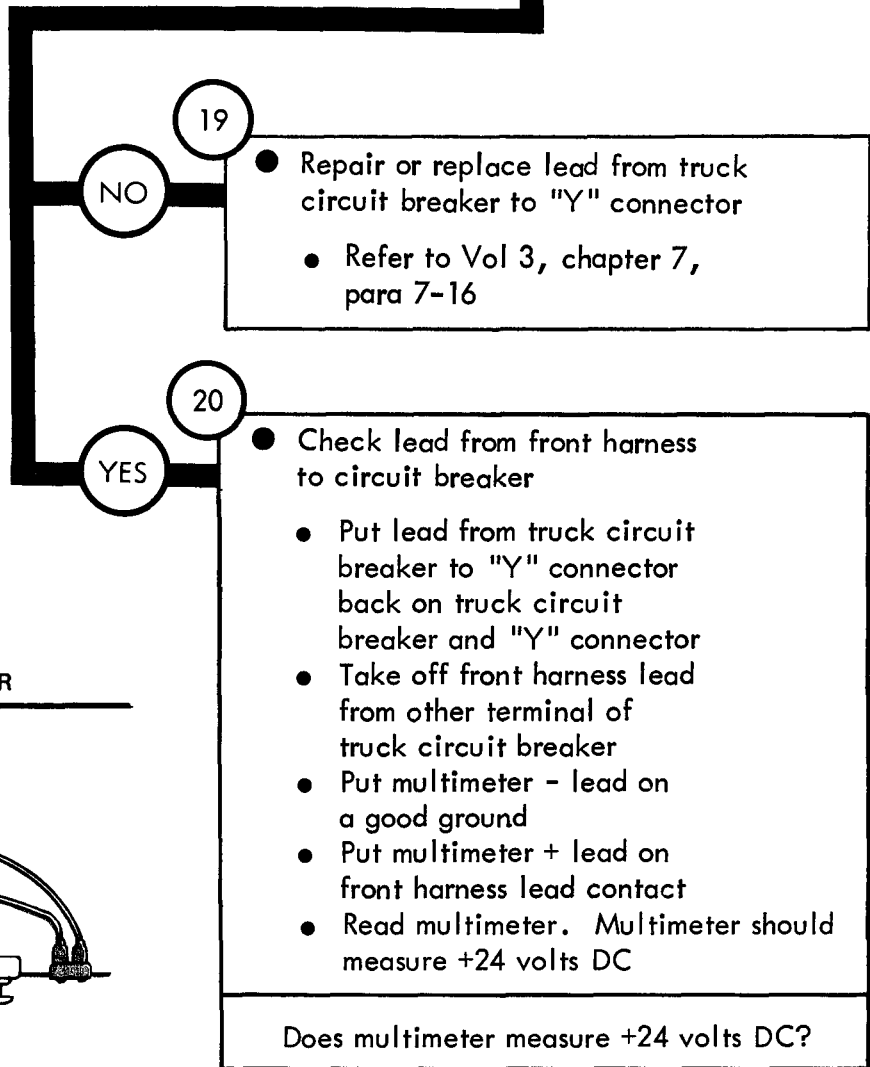

Figure 25-46 (Sheet 8 of 16)

NO GO



Does multimeter measure +24 volts DC?

NO GO

TA 114556

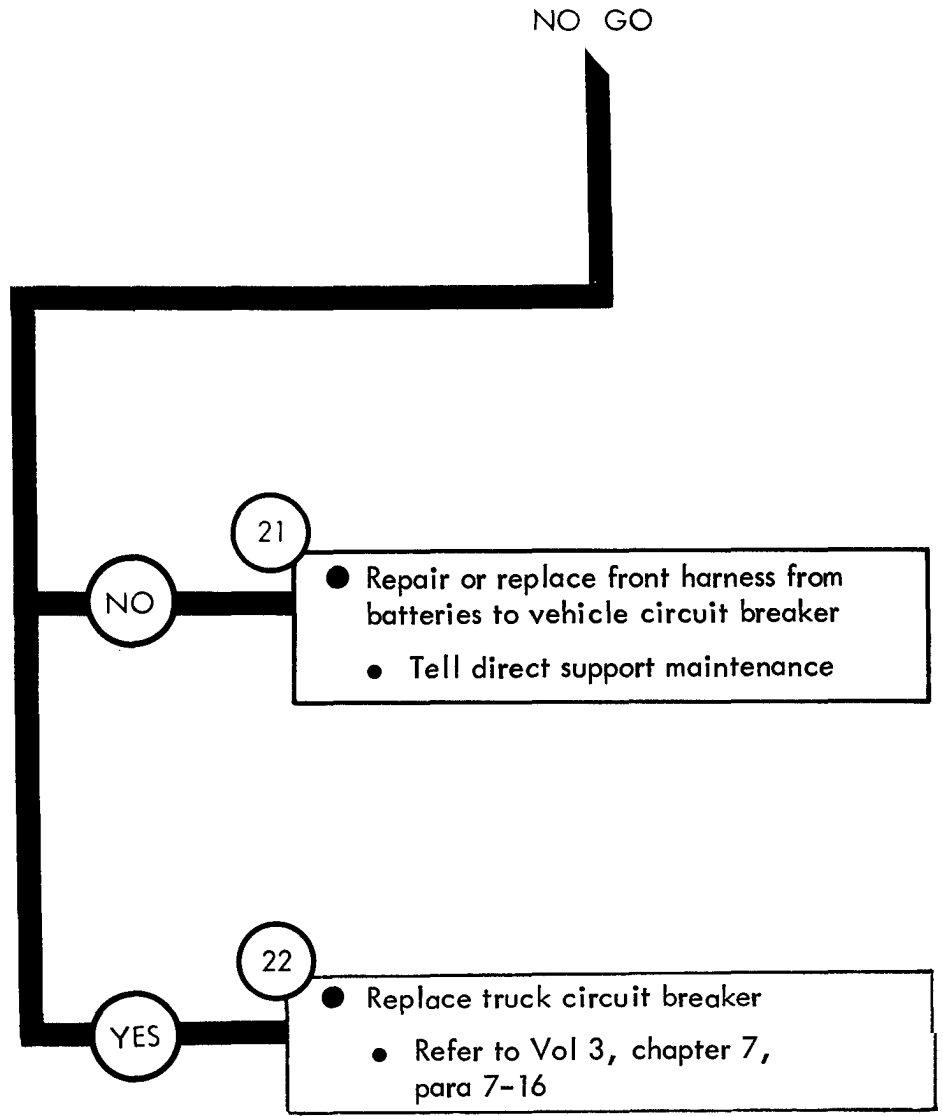

From step 4

23

- Test blower motor
 - Take off lead from heater control switch to blower motor at blower motor
 - Put multimeter - lead on a good ground
 - Put multimeter + lead on contact of lead removed from blower motor
 - Read multimeter. Multimeter should measure +24 volts DC

Does multimeter measure +24 volts DC?

GO

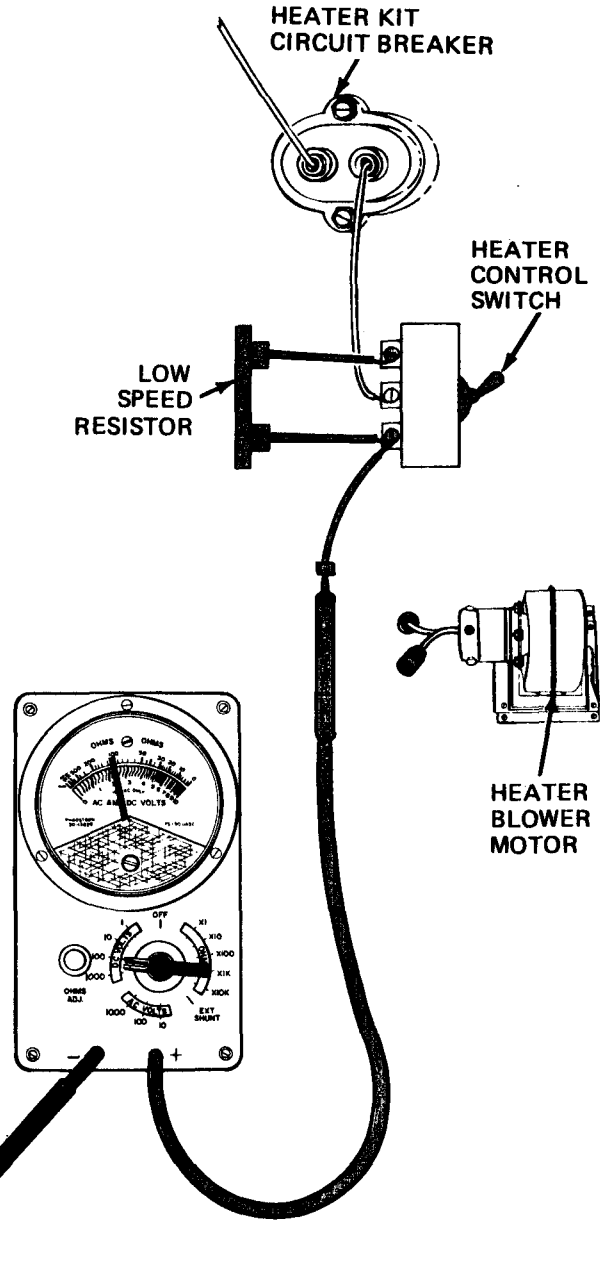

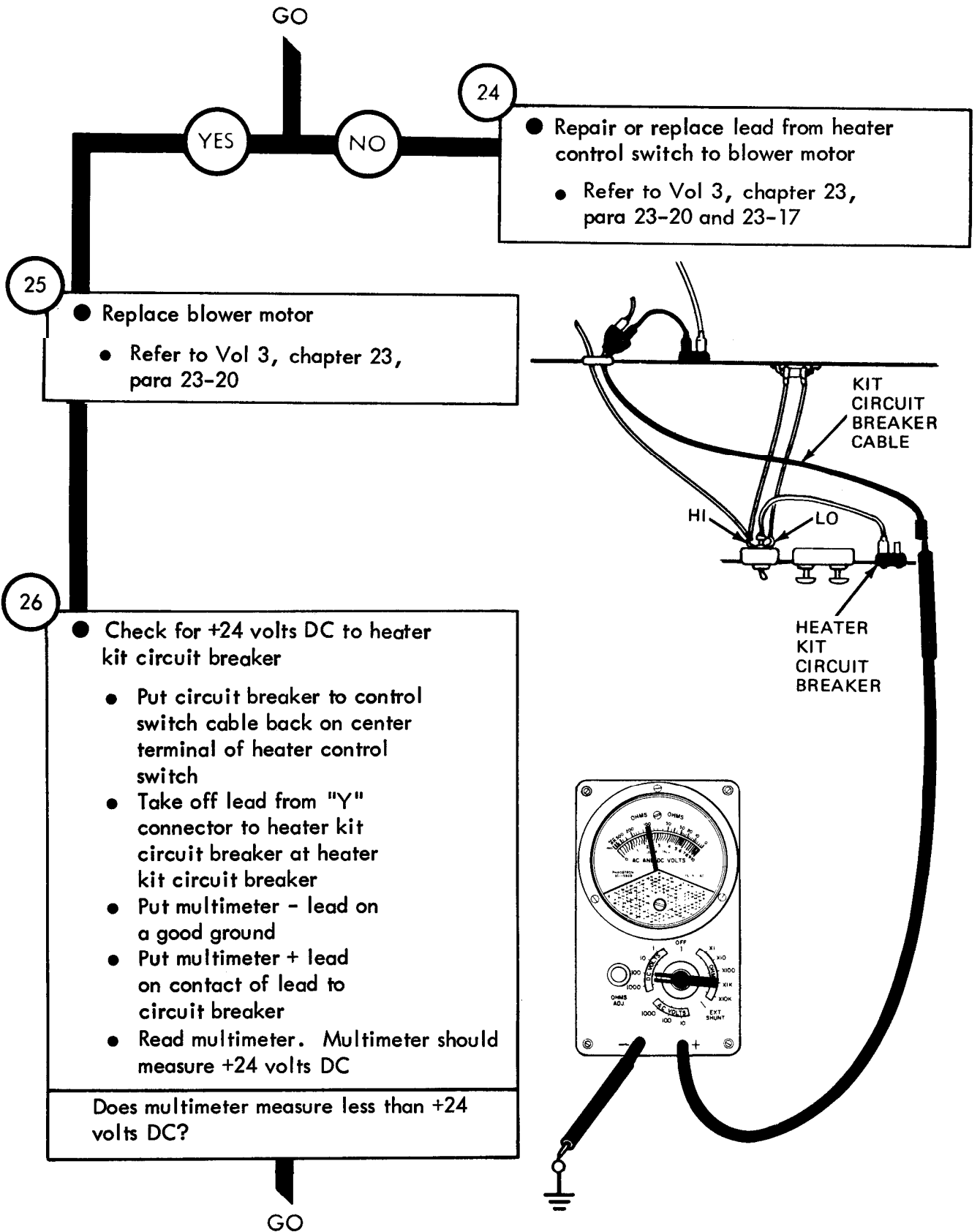

TA 114559

Figure 25-46 (Sheet 12 of 16)

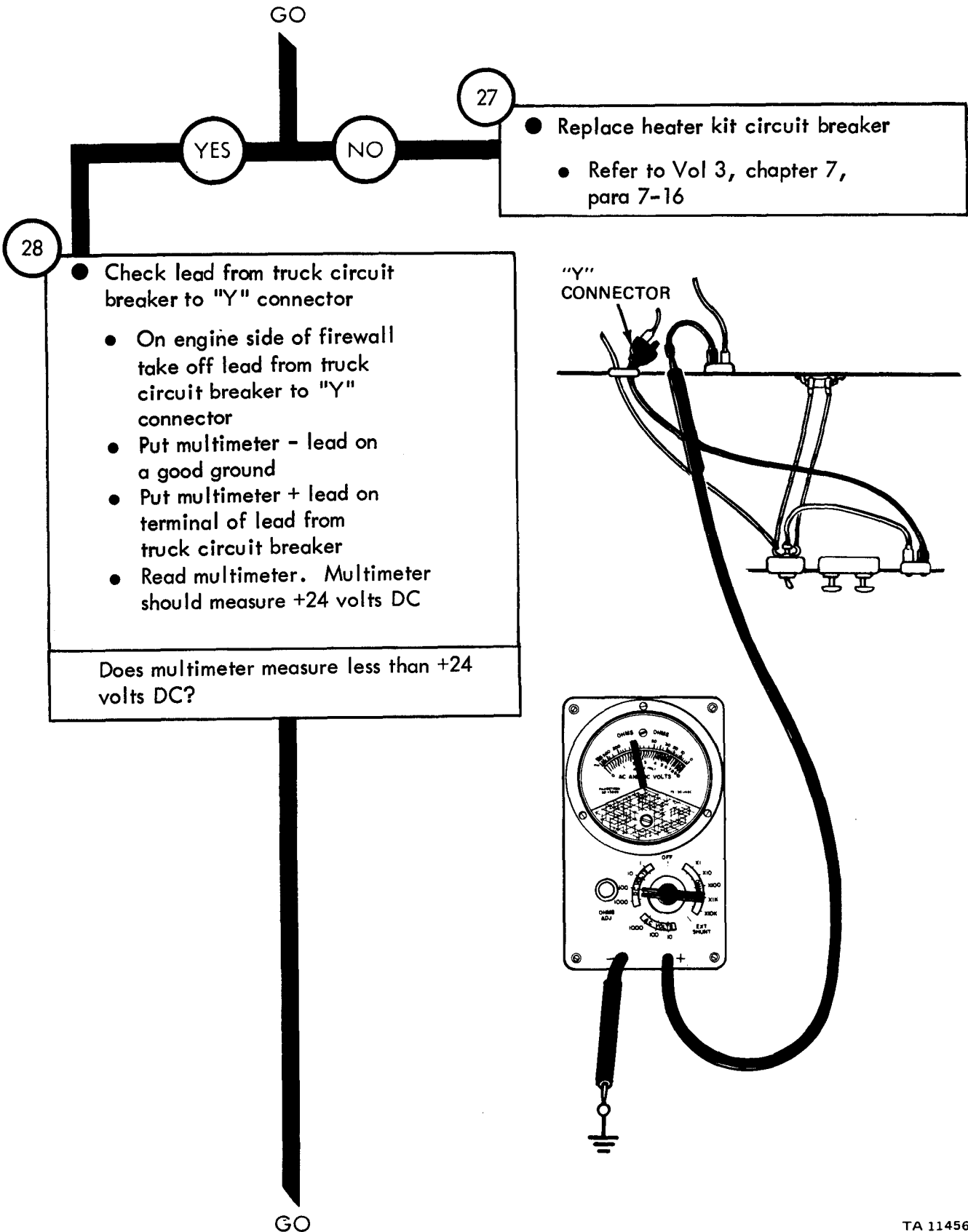

TA 114560

Figure 25-46 (Sheet 13 of 16)

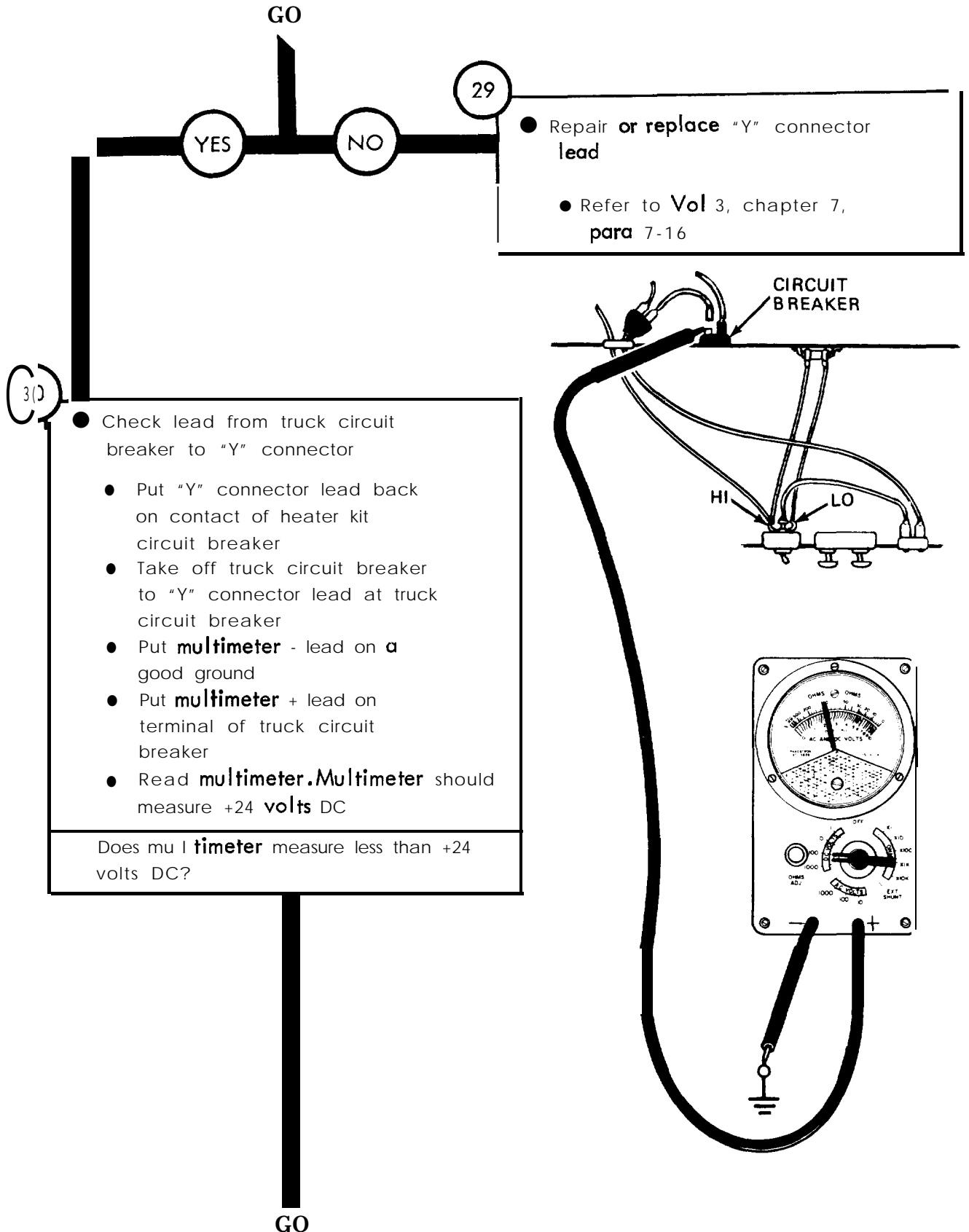
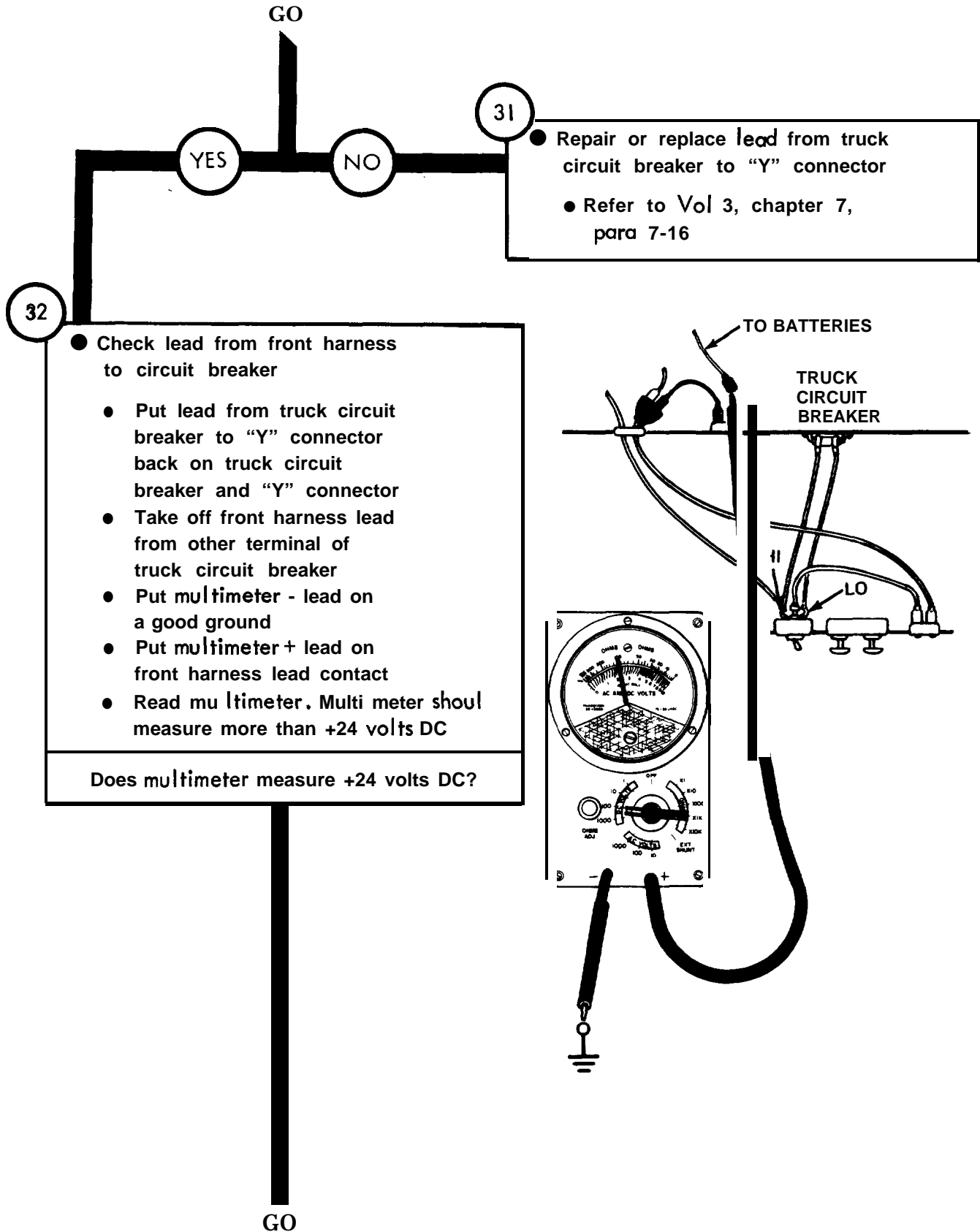

Figure 25-46 (Sheet 14 of 16)



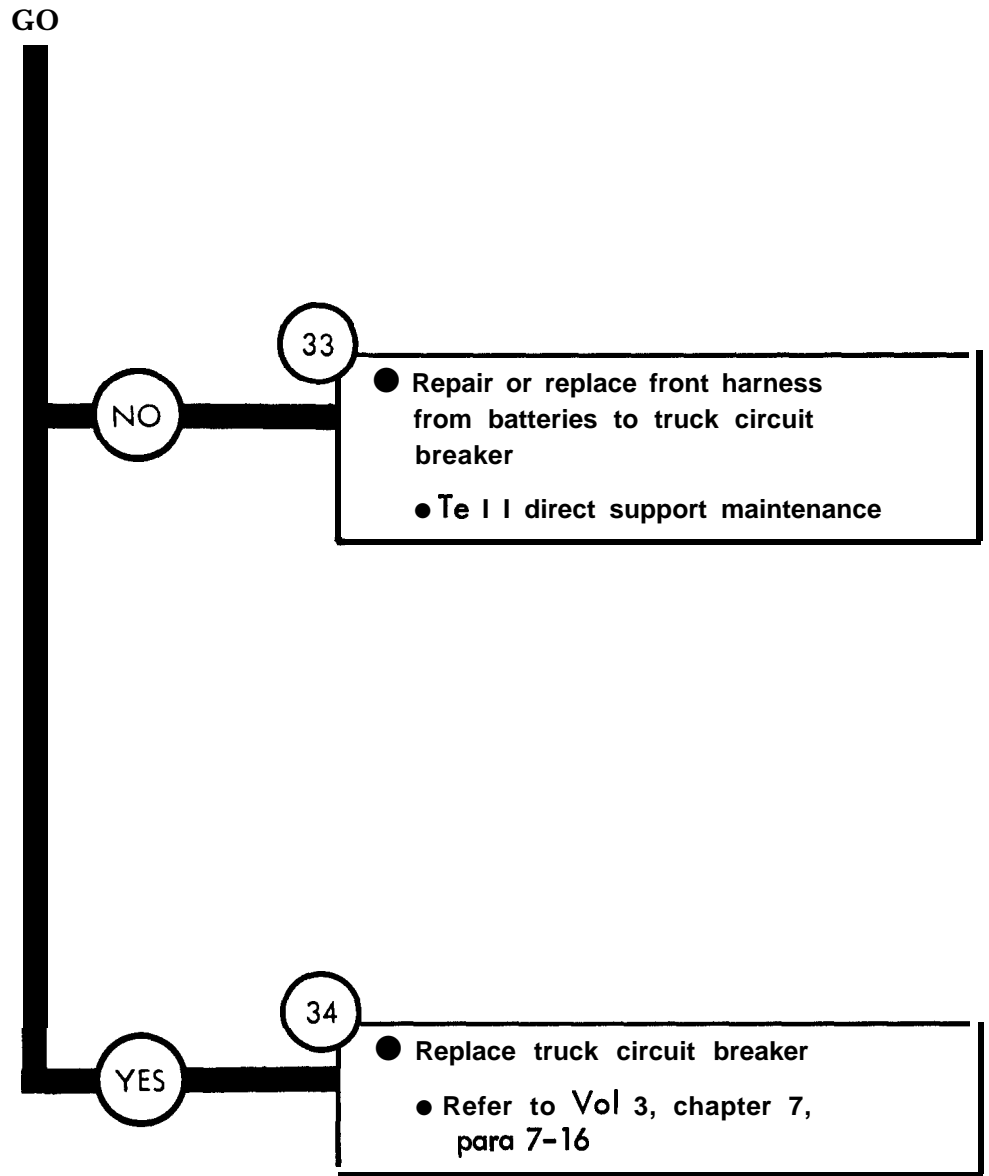

Figure 25-46 (Sheet 16 of 16)

Symptom

47

HOT WATER HEATER BLOWER DOES NOT OPERATE IN EITHER
BLOWER SWITCH POSITION

NOTE

When measuring voltage +24 volts DC
means a range of +23 to +26 volts DC

1

- Park truck
- Refer to TM 9-2320-209-10

GO

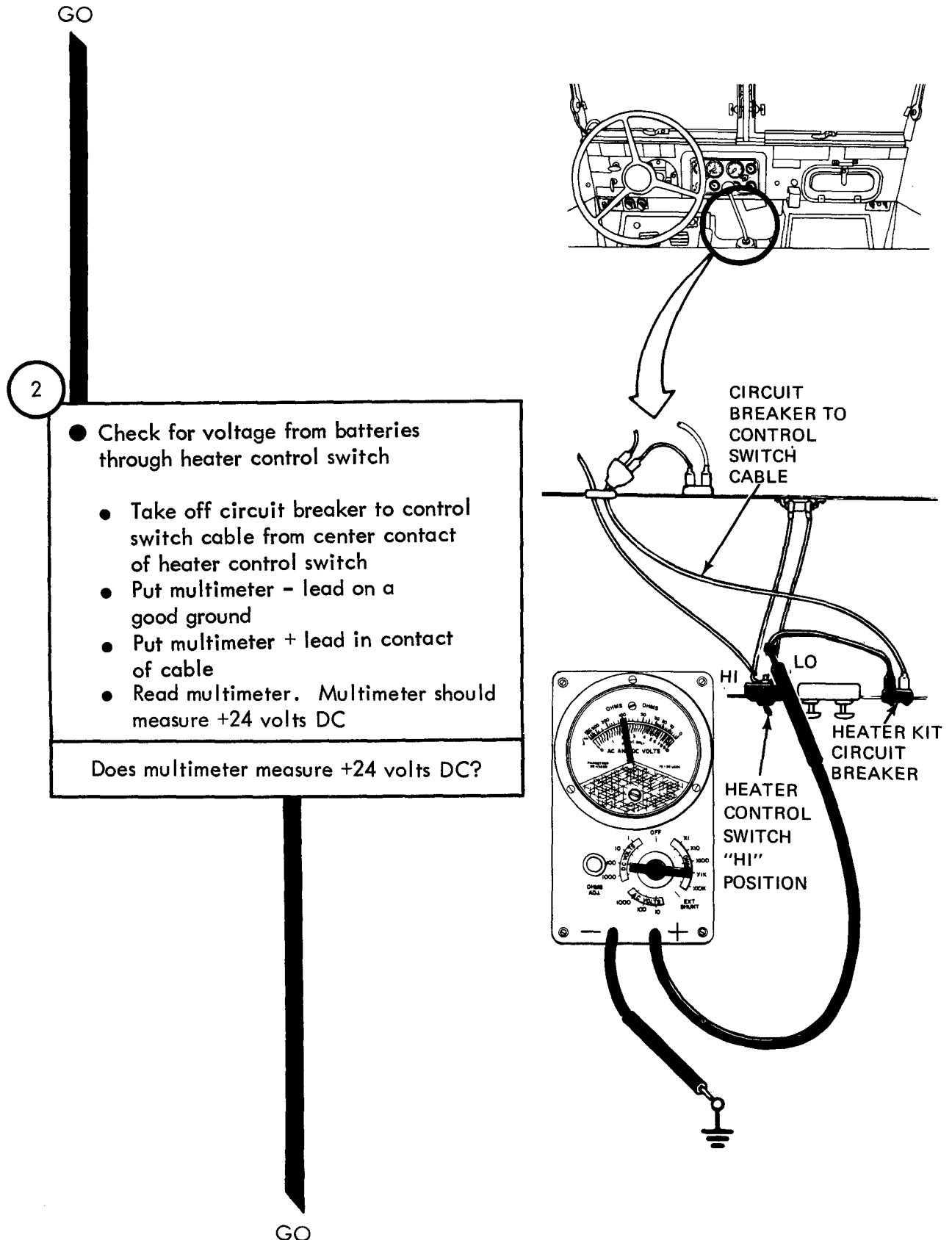

Figure 25-47 (Sheet 2 of 11)

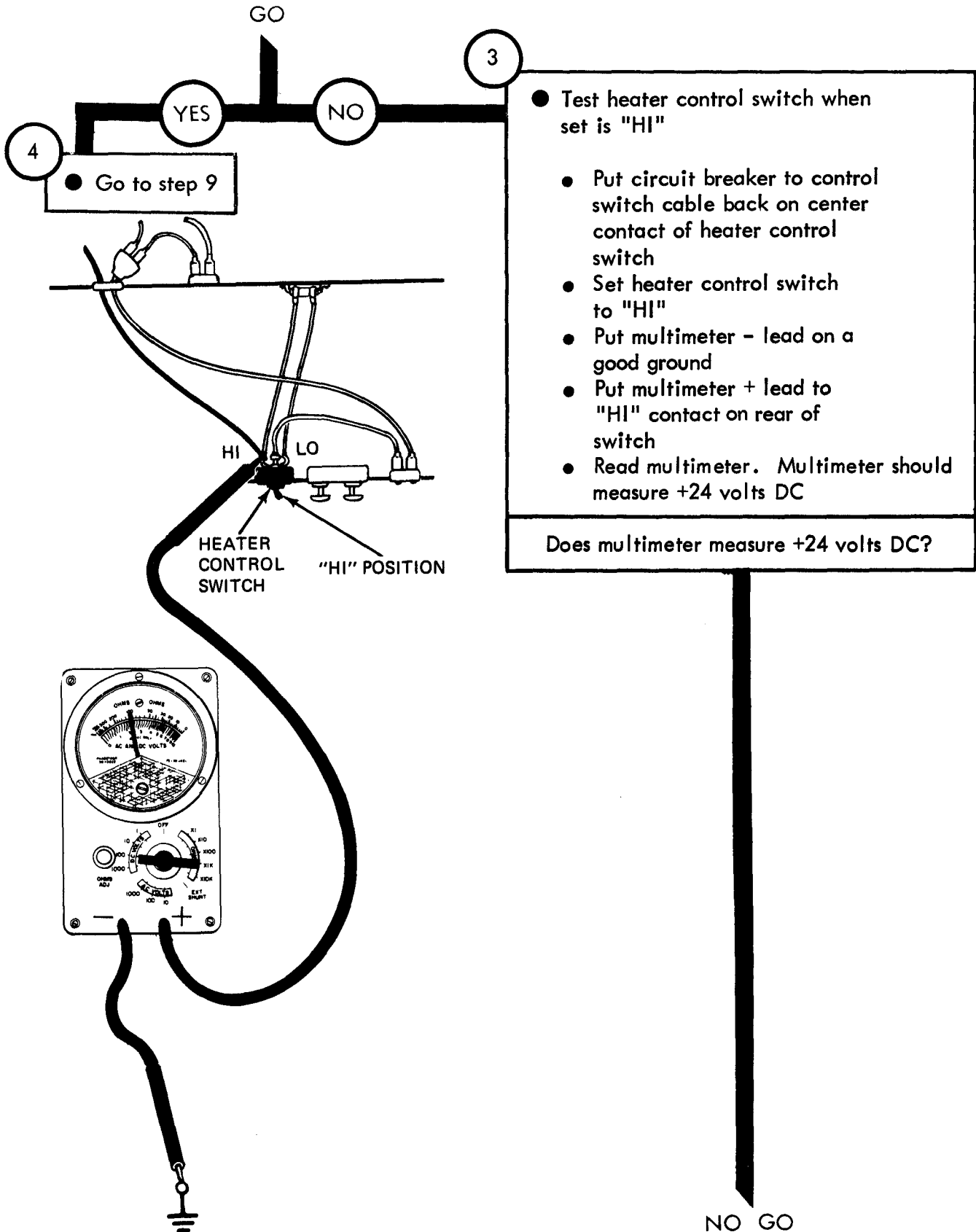
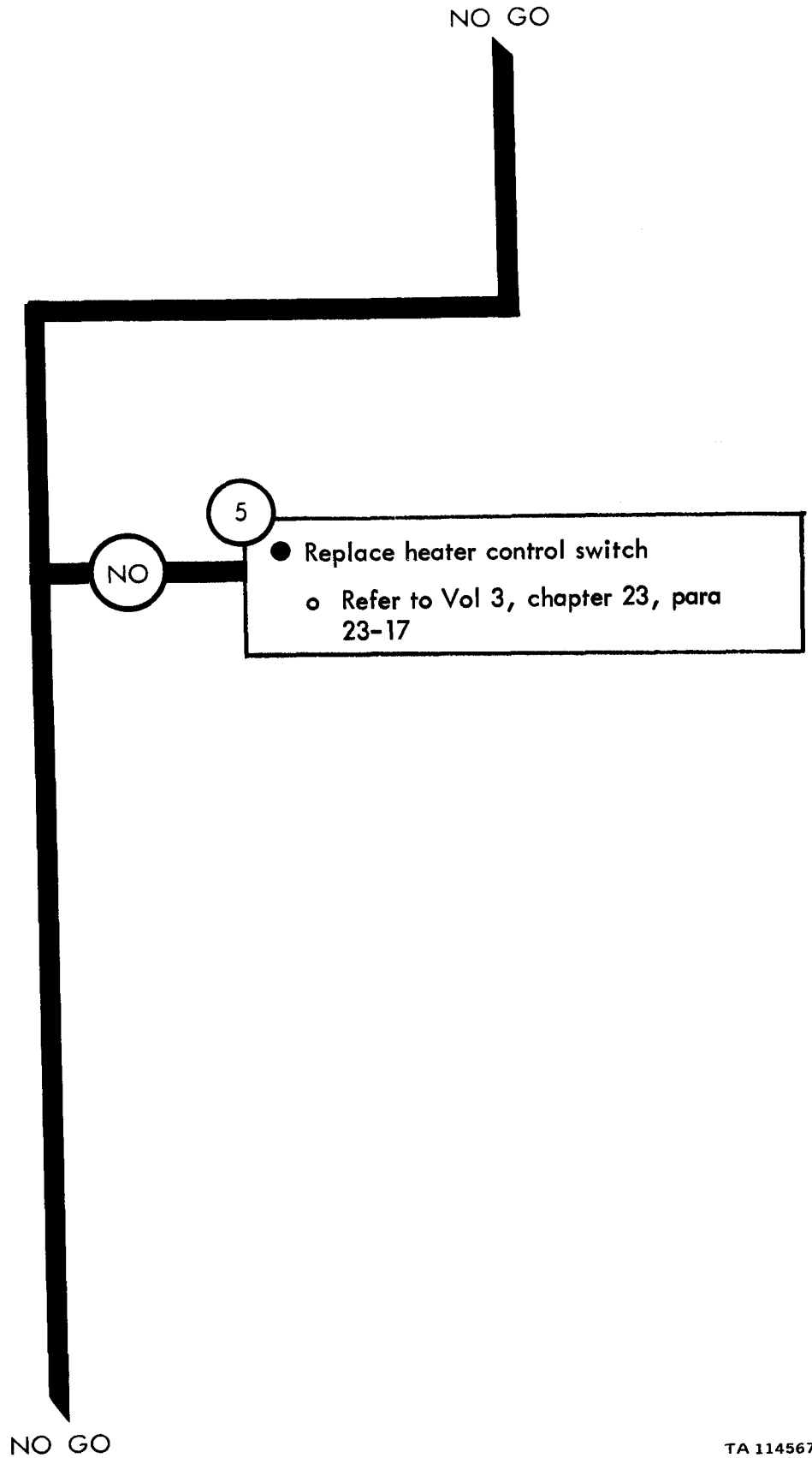

Figure 25-47 (Sheet 3 of 11)



NO GO

TA 114567

Figure 25-47 (Sheet 4 of 11)

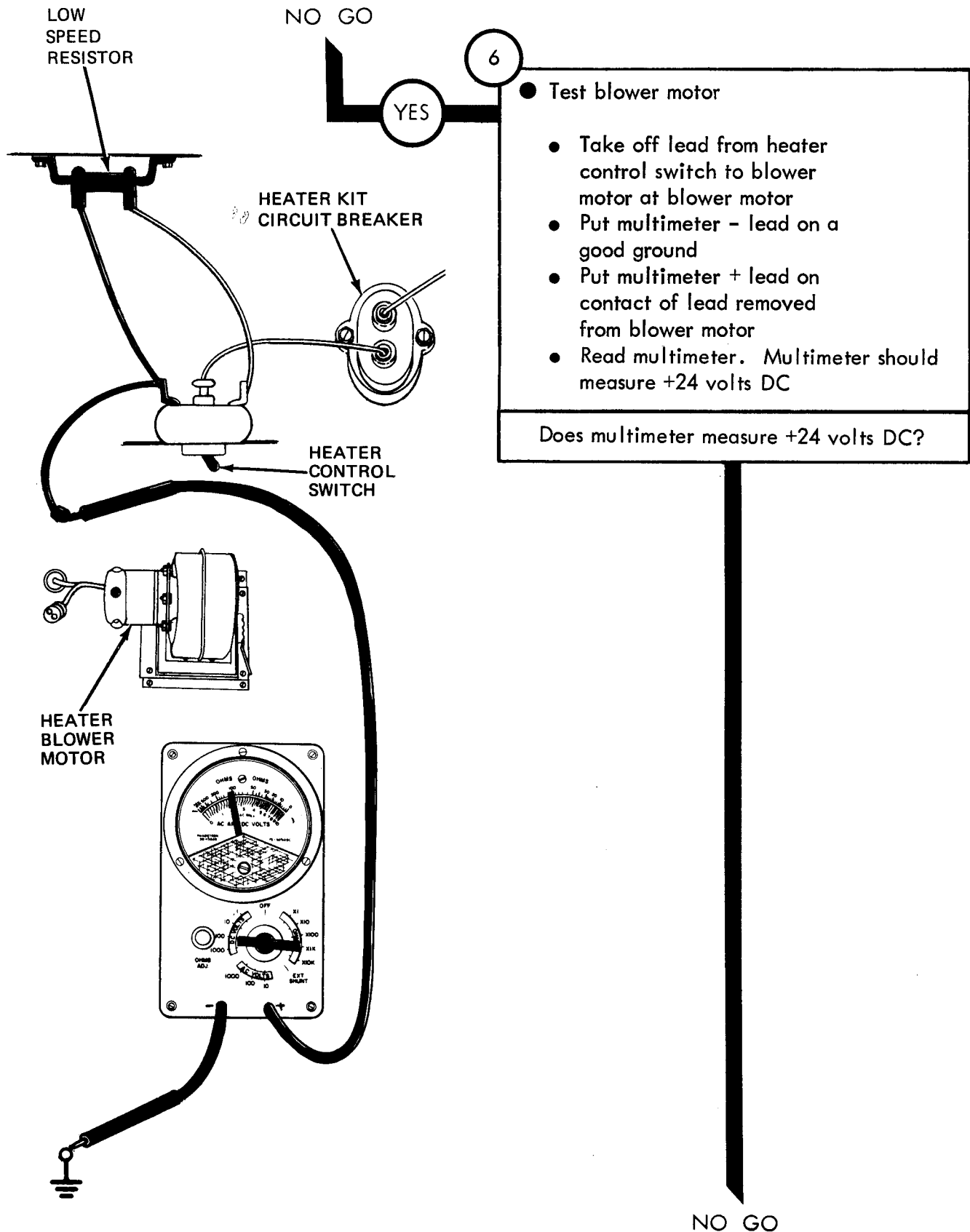
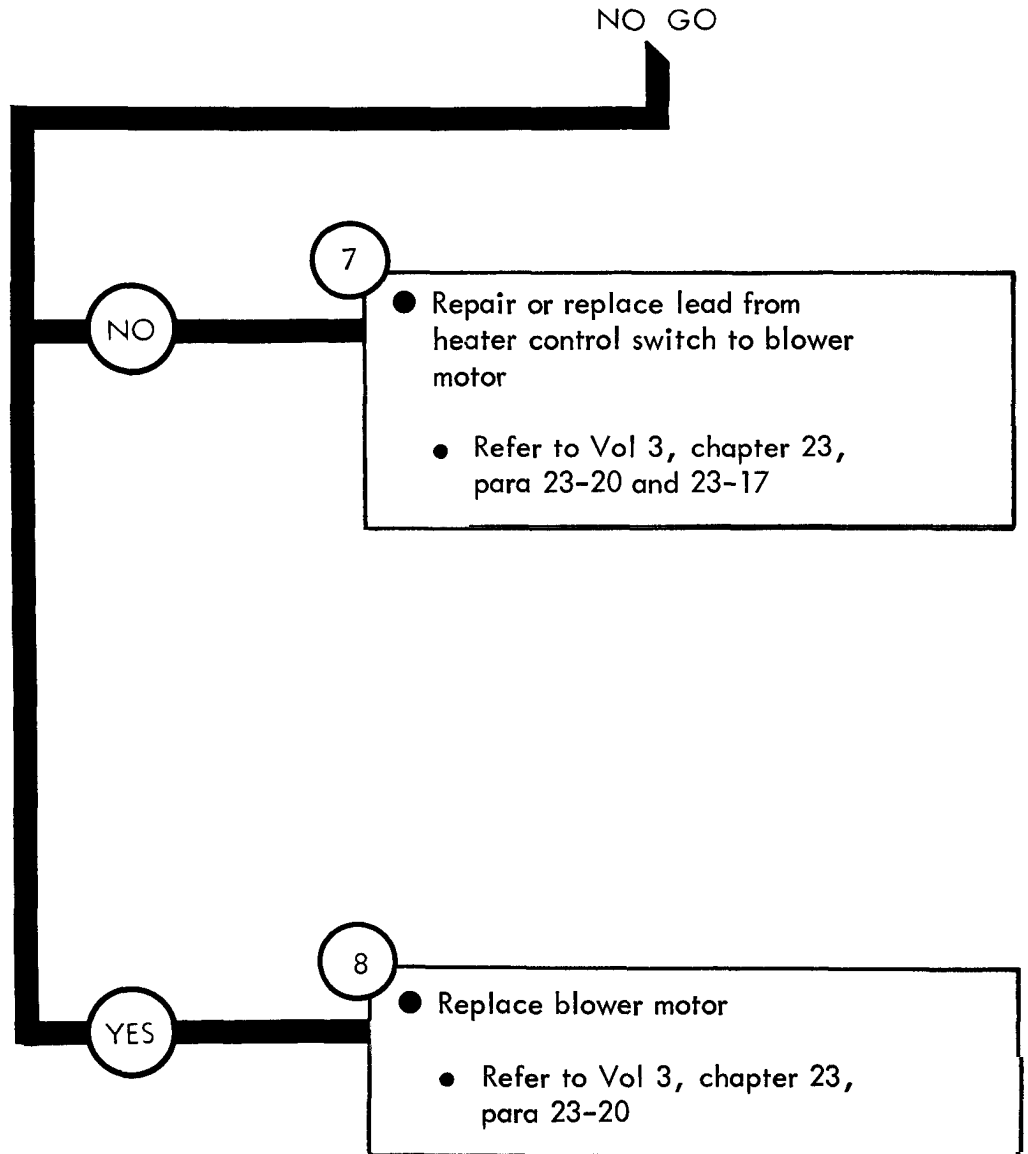

Figure 25-47 (Sheet 5 of 11)



From step 4

9

- Check for +24 volts DC to heater kit of circuit breaker
- Put circuit breaker to control switch cable back on center terminal of heater control switch
- Take off lead from "Y" connector to heater kit circuit breaker at heater kit circuit breaker
- Put multimeter - lead on a good ground
- Put multimeter + lead on contact of lead to heater kit circuit breaker
- Read multimeter. Multimeter should measure +24 volts DC

Does multimeter measure less than +24 volts DC?

GO

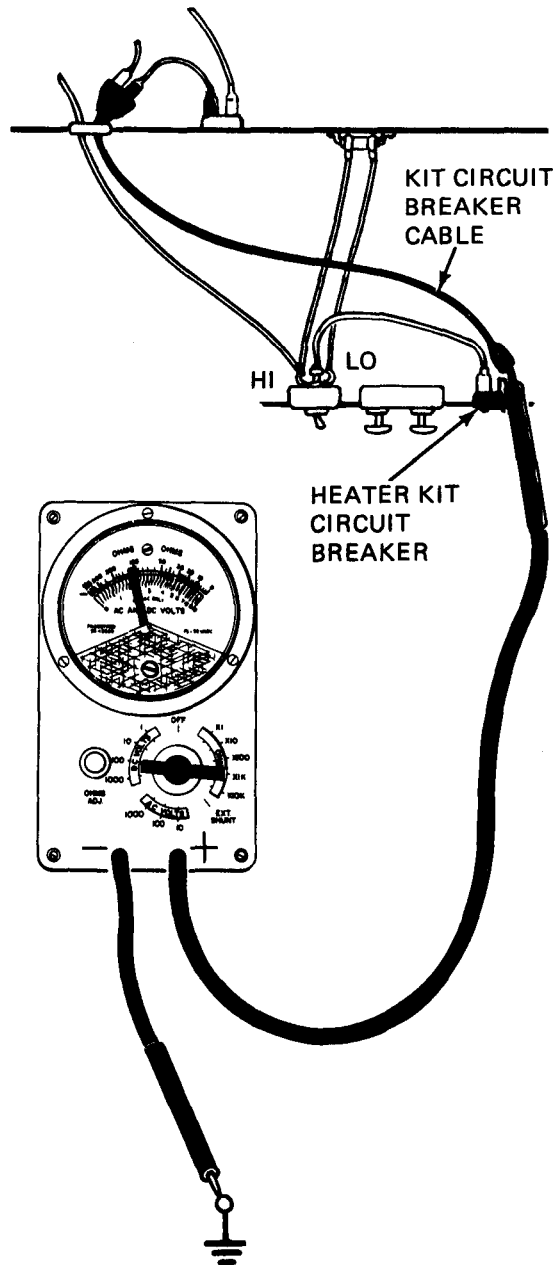

TA 114570

Figure 25-47 (Sheet 7 of 11)

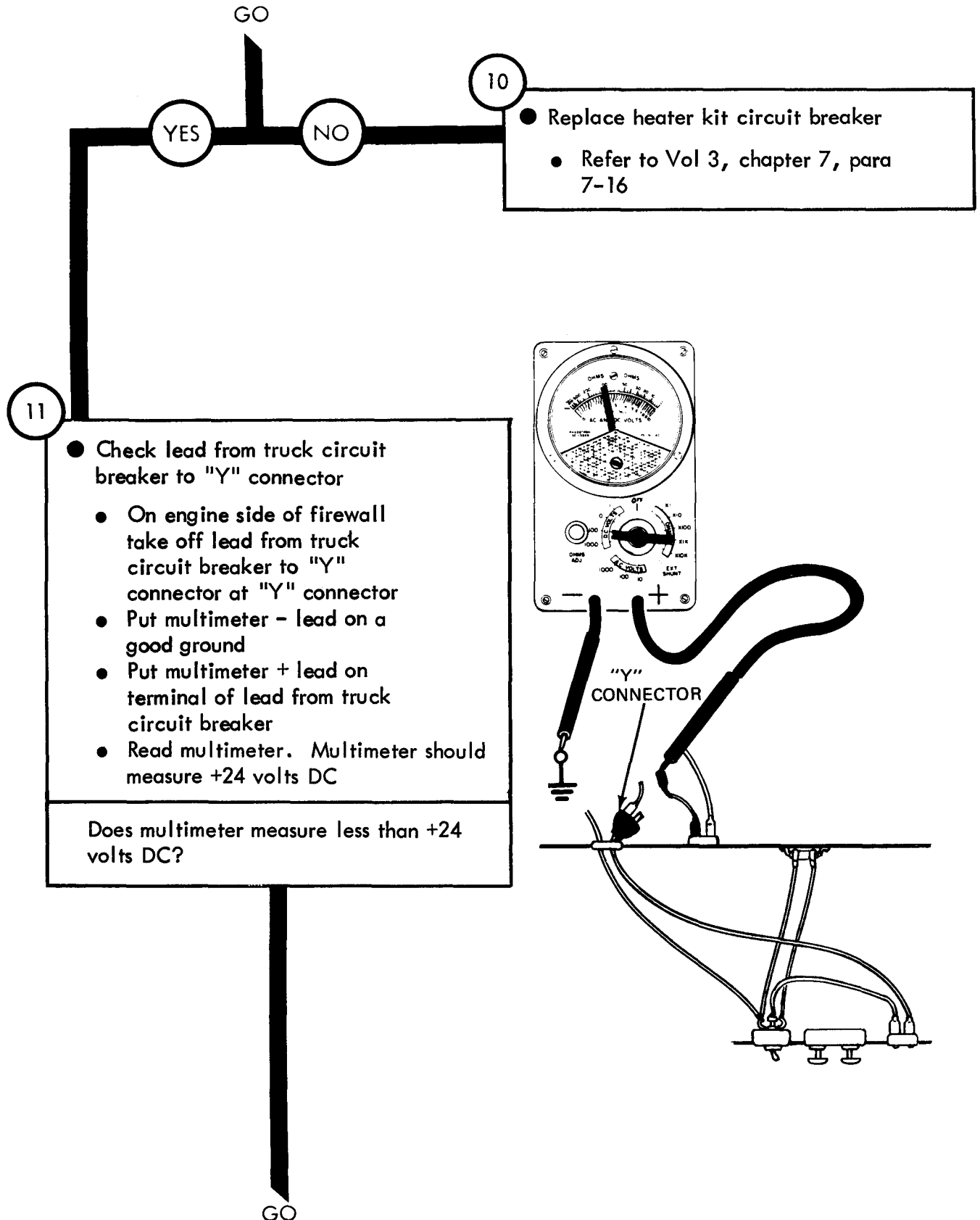

Figure 25-47 (Sheet 8 of 11)

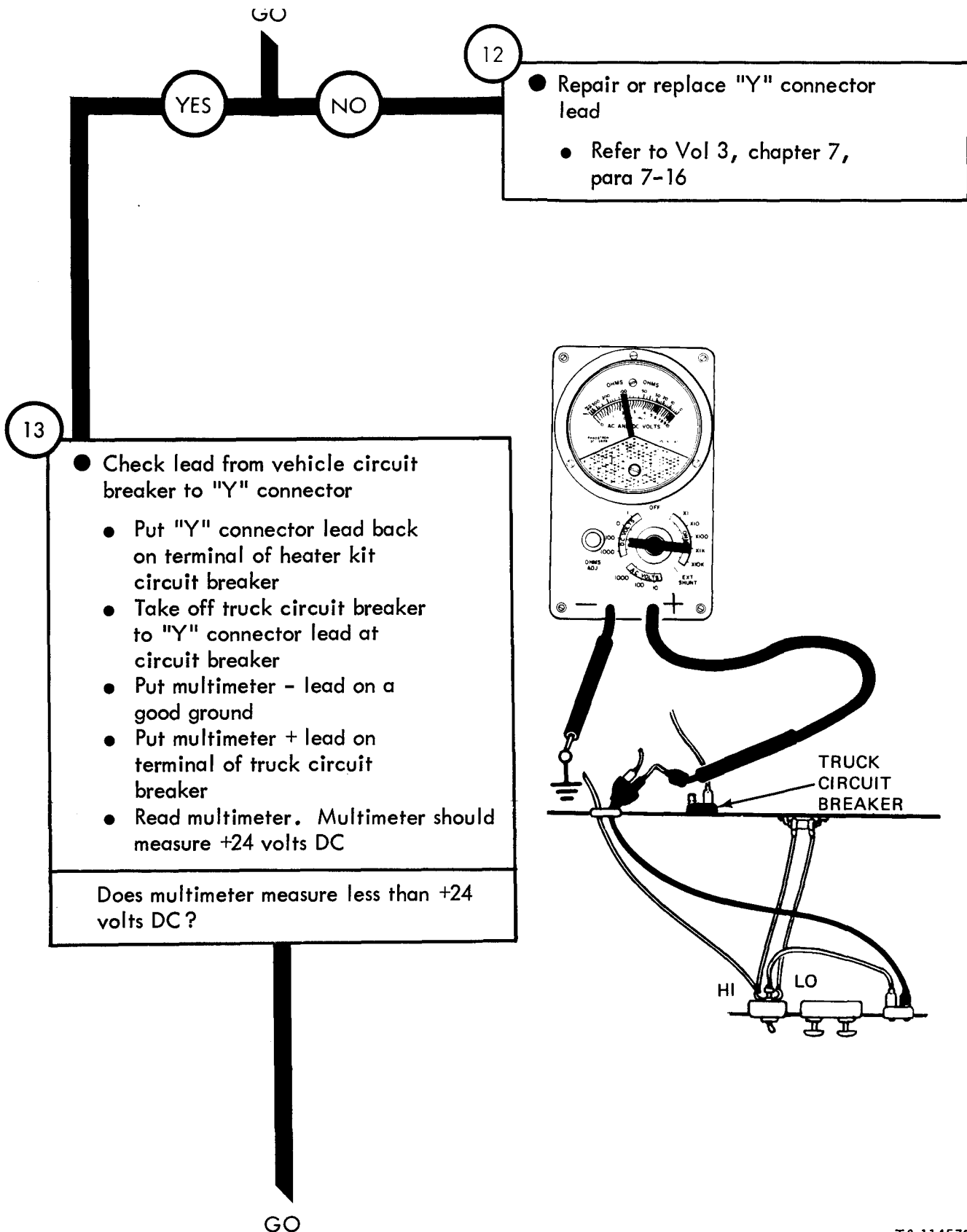
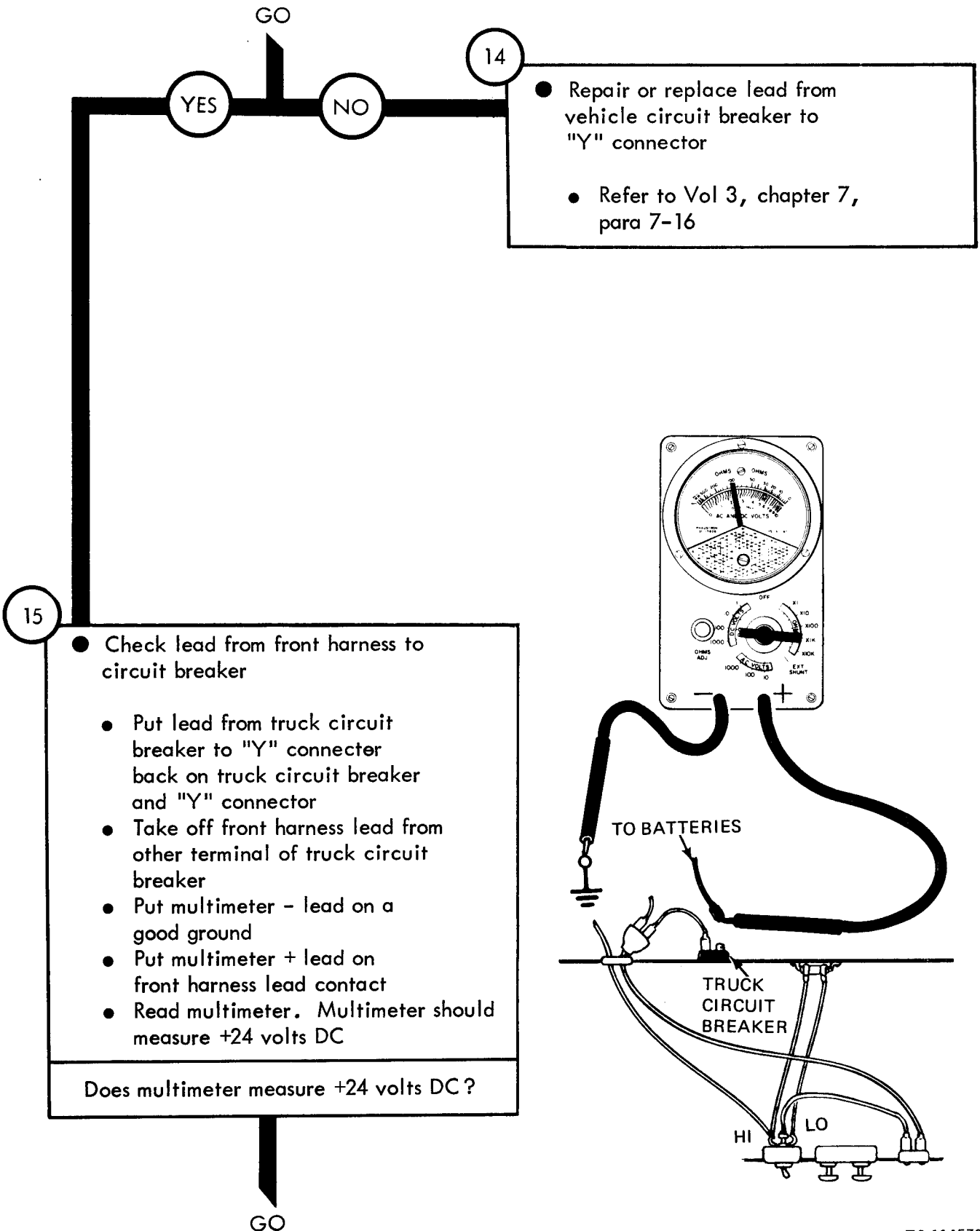

Figure 25-47 (Sheet 9 of 11)

TA 114572



TA 114573

Figure 25-47 (Sheet 10 of 11)

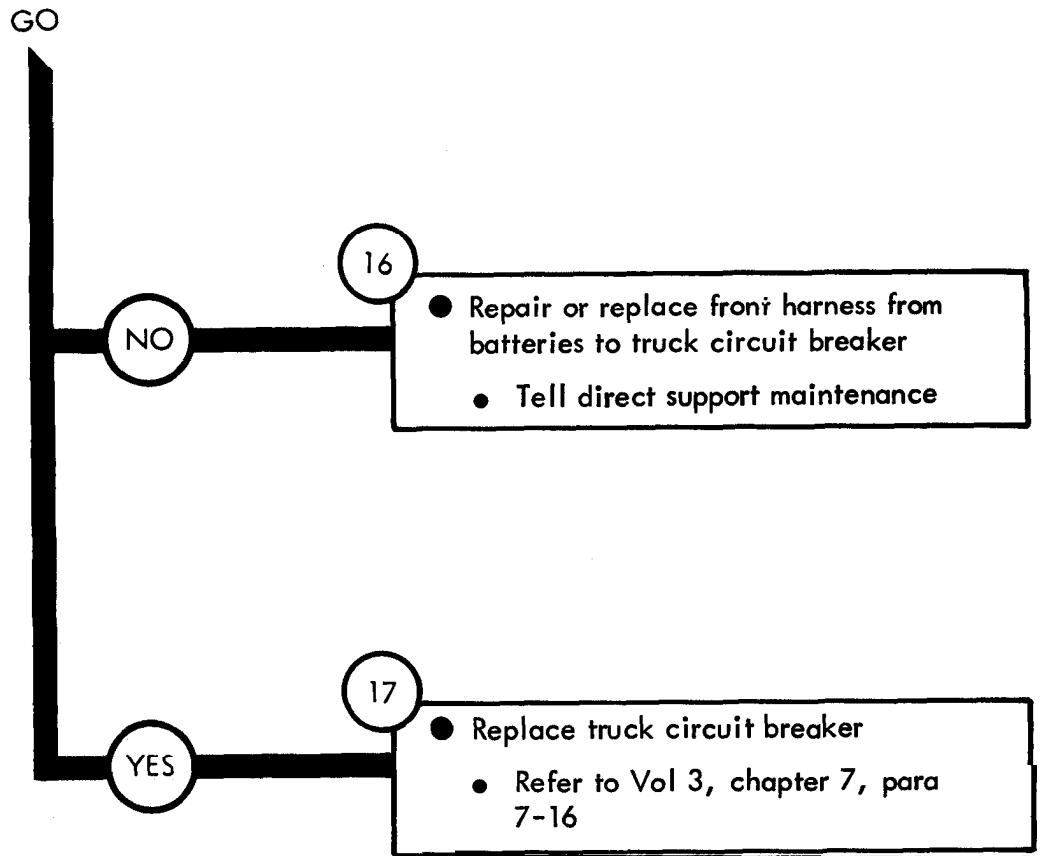

Figure 25-47 (Sheet 10 of 11)

48

HOT WATER PERSONNEL HEATER DOES NOT TURN OFF WHEN SWITCH IS IN OFF POSITION

NOTE

When measuring voltage +24 volts DC means a range of +23 to +26 volts DC

1

- Park truck
- Refer to TM 9-2320-209-10

GO

GO

2

- Check for bad heater control switch or shorted leads
- Set heater control switch to "OFF"
- Set multimeter to measure +24 volts DC. Refer to test equipment procedures index, test 1
- Put multimeter - lead on a good ground
- Put multimeter + lead on "LO" contact of heater switch. Read multimeter
- Put multimeter + lead on "HI" contact of heater switch. Read multimeter

Did multimeter measure +24 volts DC on either contact?

GO

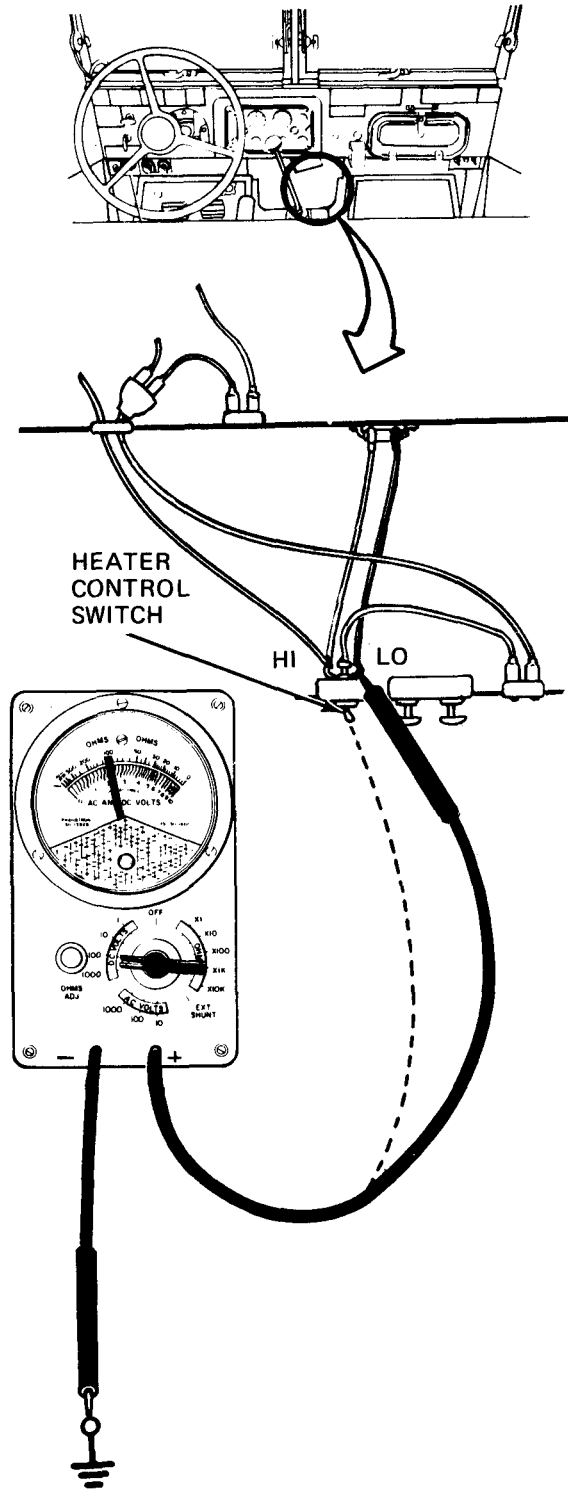

Figure 25-48 (Sheet 2 of 3)

TA 114576

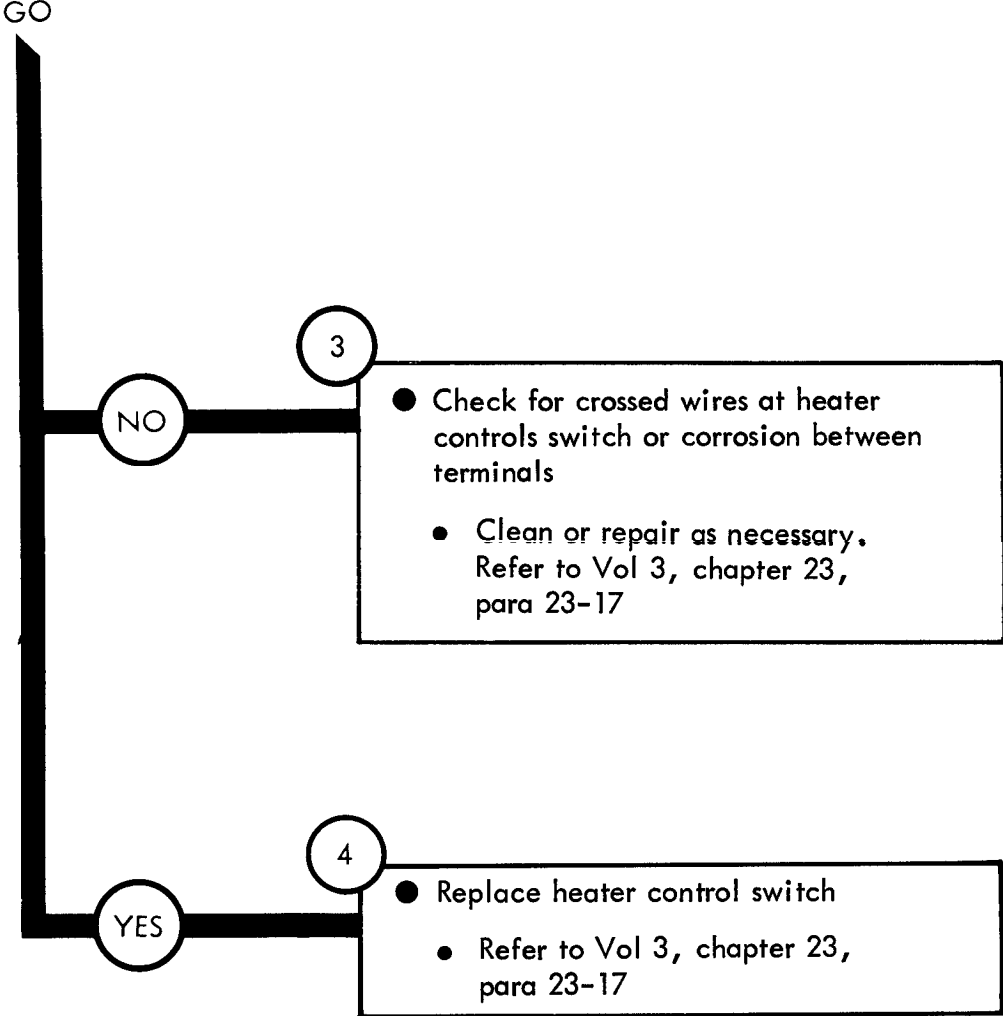

Figure 25-48 (Sheet 3 of 3)

Symptom

49

ONLY ONE CONTROL BOX WILL OPERATE THE HEATER FUEL PUMP

NOTE

When measuring voltage +24 volts DC means a range of +23 to +26 volts DC

1

- Park truck
- Refer to TM 9-2320-209-10

GO

Figure 25-49 (Sheet 1 of 9)

TA 114578

GO

2

- Check voltage from power plant heater control box
 - Make sure the lead from power plant heater control box to fuel pump is clean and tightly connected
 - Turn on control box
 - If control box still won't work shut it off
 - Take off lead from control box to fuel pump at power plant heater control box

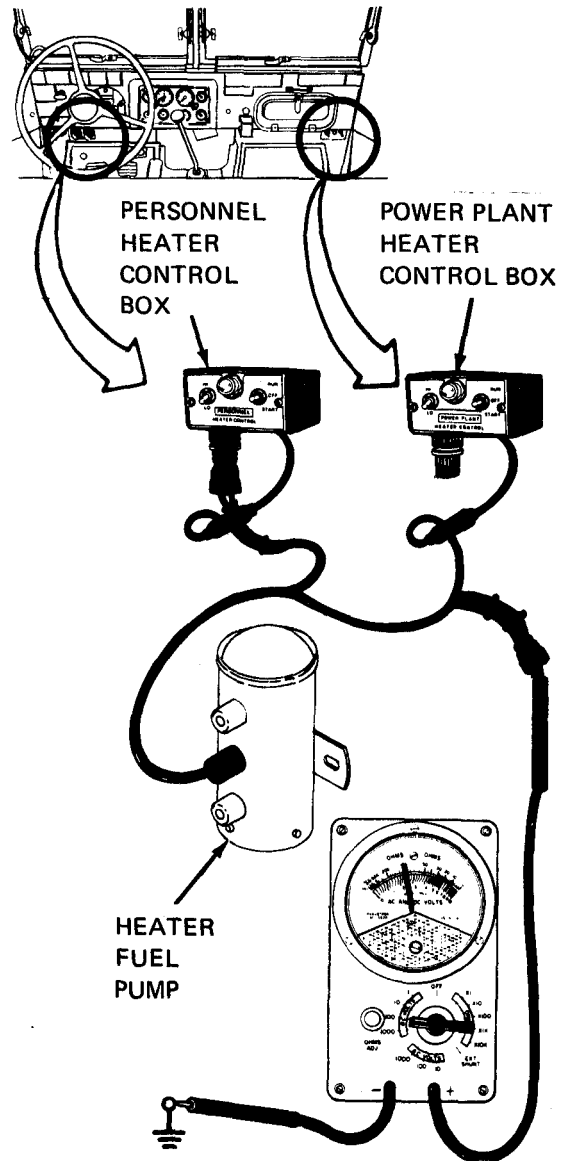

- Turn on heater control box
- Set multimeter to measure +24 volts DC. Refer to test equipment procedures index
- Put multimeter - lead on good ground
- Put multimeter + lead on terminal "A" of control box connector
- Read multimeter. Multimeter should measure +24 volts DC

Does multimeter measure less than +24 volts DC?

YES

NO

3

GO

- Repair or replace lead between power plant heater control box and fuel pump
- Tell direct support maintenance

Figure 25-49 (Sheet 2 of 9)

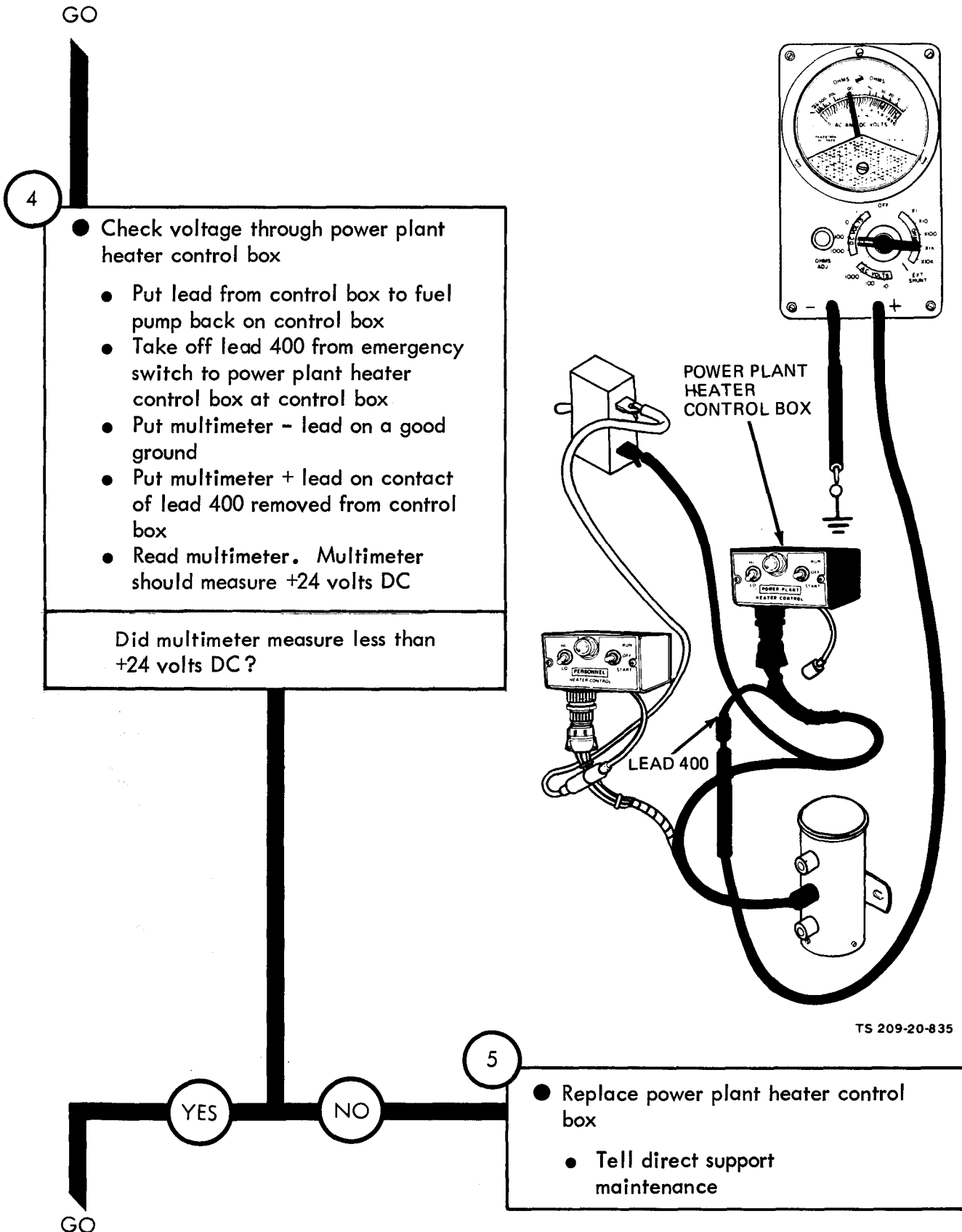
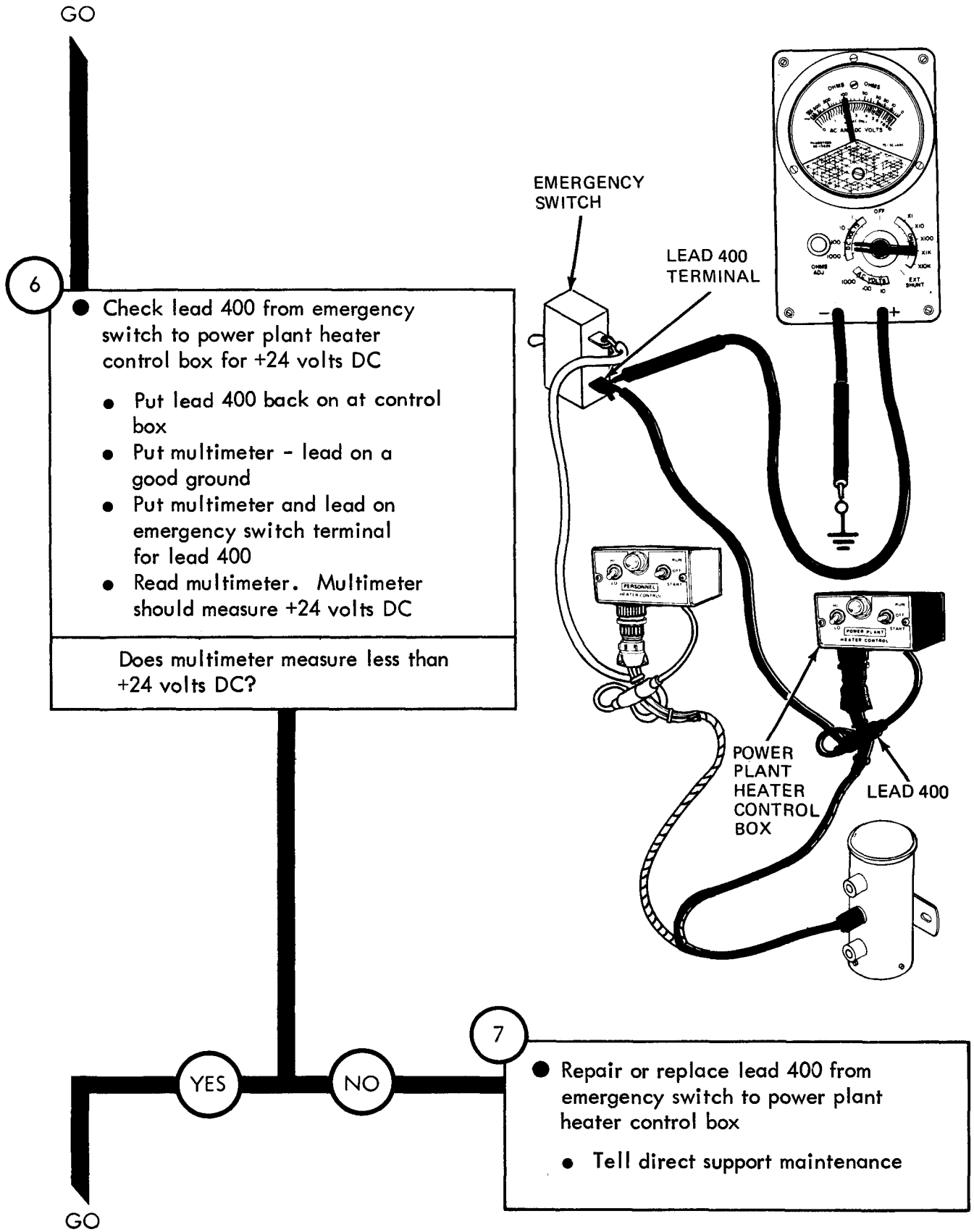

Figure 25-49 (Sheet 3 of 9)



6

- Check lead 400 from emergency switch to power plant heater control box for +24 volts DC
 - Put lead 400 back on at control box
 - Put multimeter - lead on a good ground
 - Put multimeter and lead on emergency switch terminal for lead 400
 - Read multimeter. Multimeter should measure +24 volts DC

Does multimeter measure less than +24 volts DC?

YES

NO

7

- Repair or replace lead 400 from emergency switch to power plant heater control box
 - Tell direct support maintenance

GO

Figure 25-49 (Sheet 4 of 9)

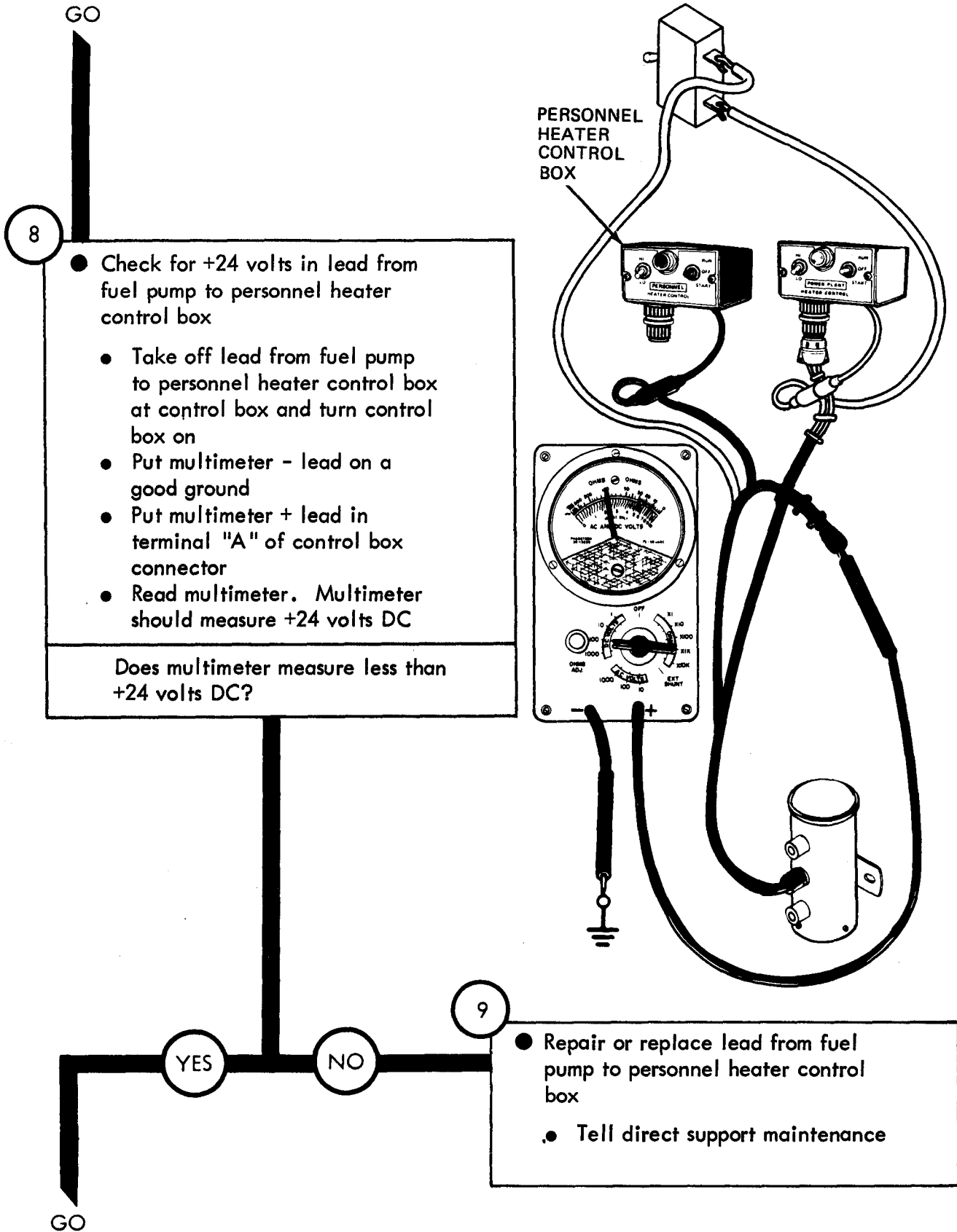

TA 114582

GO

10

- Check for +24 volts through personnel heater control box
 - Put lead from fuel pump to personnel heater control box back on at control box
 - Take off lead 400 from personnel heater control box
 - Put multimeter - lead on a good ground
 - Put multimeter + lead on contact of lead 400
 - Read multimeter. Multimeter should measure +24 volts DC

Does multimeter measure less than +24 volts DC?

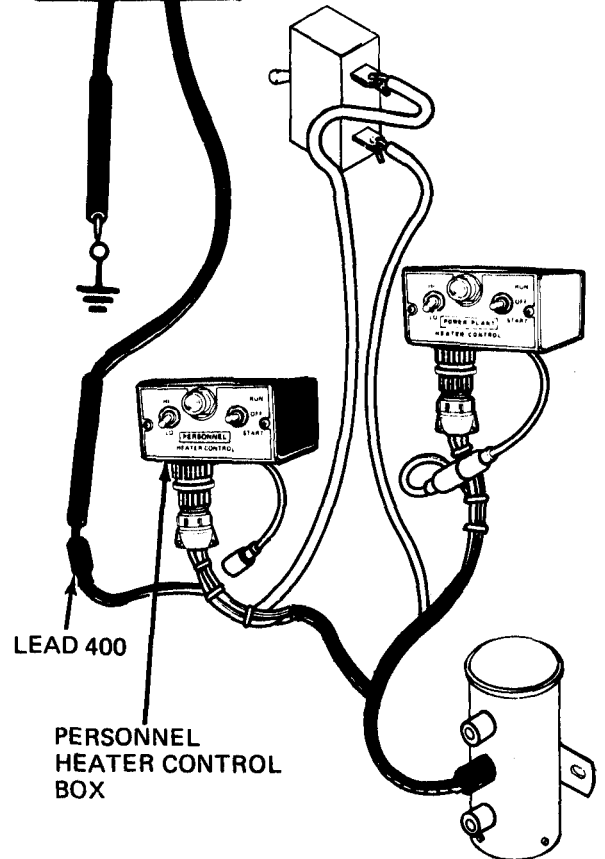
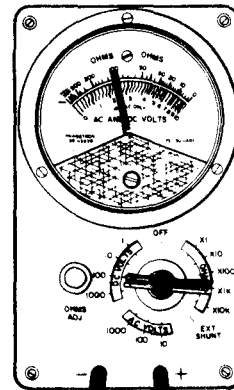

YES

NO

11

- Repair or replace personnel heater control box
 - Tell direct support maintenance

GO

Figure 25-49 (Sheet 6 of 9)

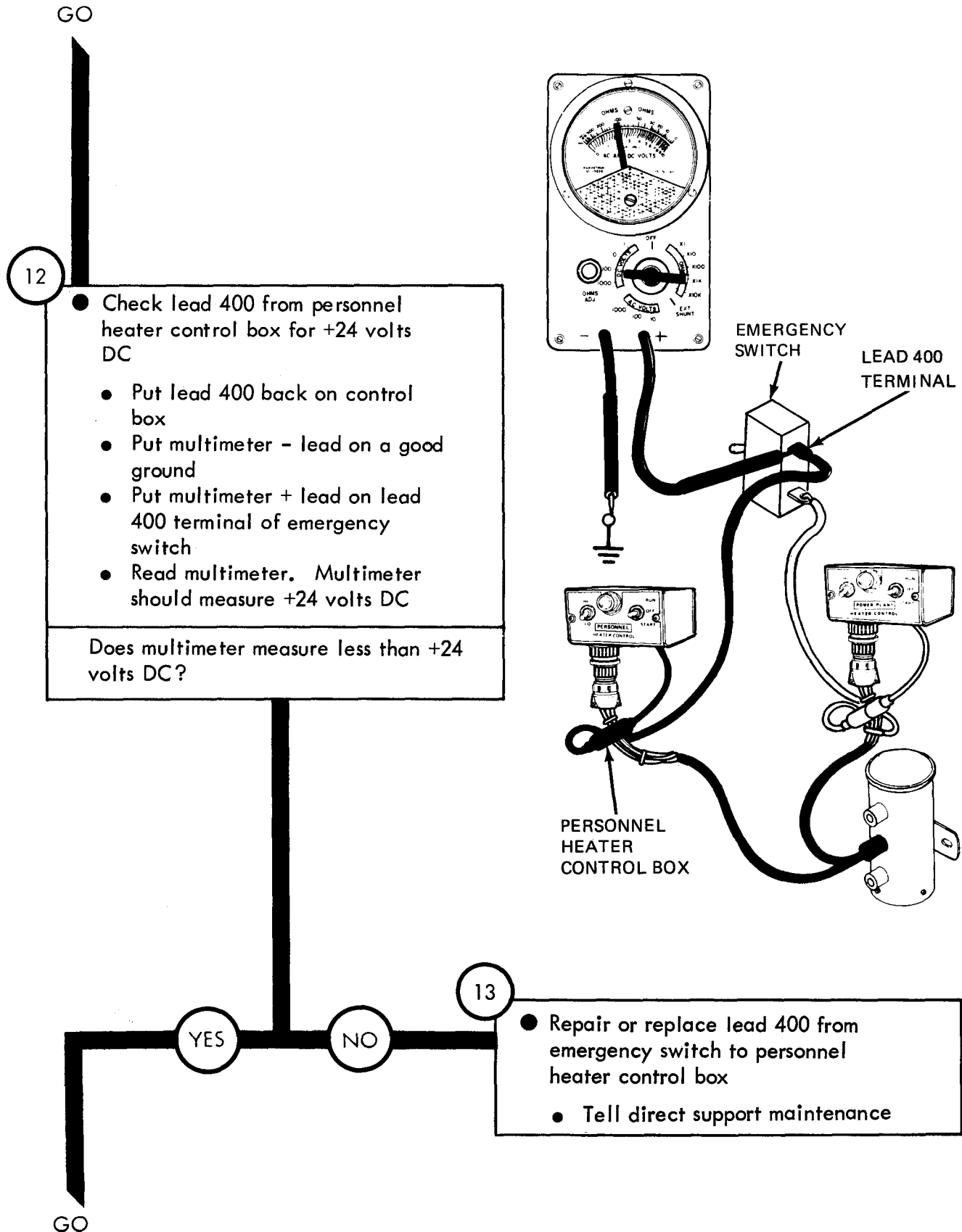

Figure 25-49 (Sheet 7 of 9)

GO

14

- Check voltage through heater control box
 - At emergency switch take off lead from truck circuit breaker
 - Put multimeter - lead on a good ground
 - Put multimeter + lead on lead 400 terminal of emergency switch that contains lead from front harness
 - Read multimeter. Multimeter should measure +24 volts DC

Does multimeter measure +24 volts DC?

GO

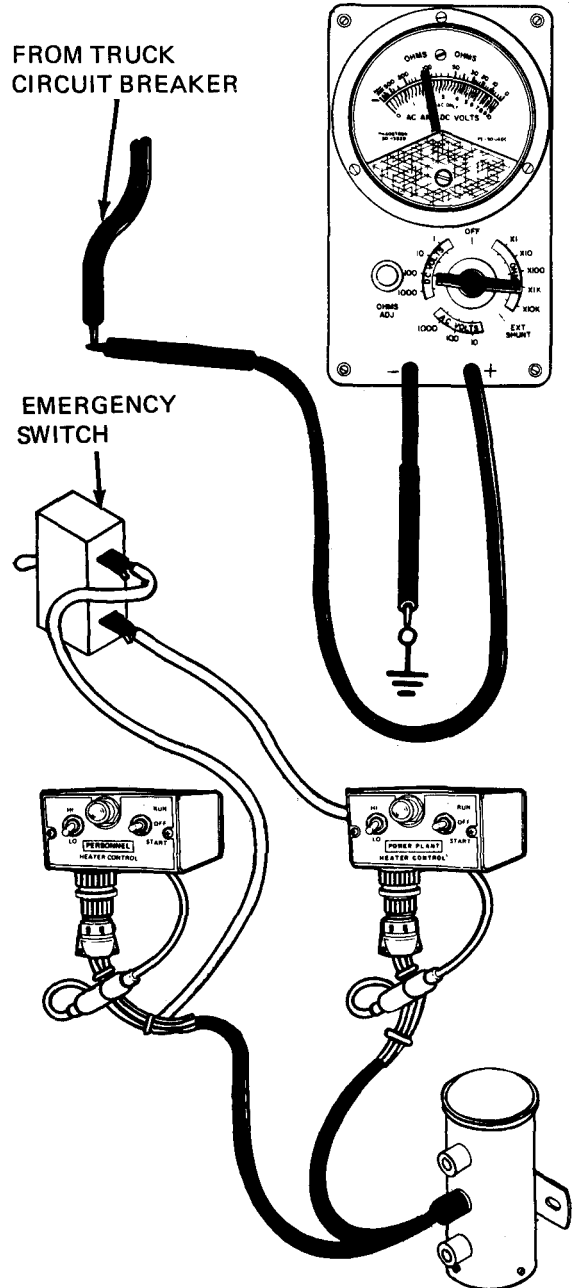

Figure 25-49 (Sheet 8 of 9)

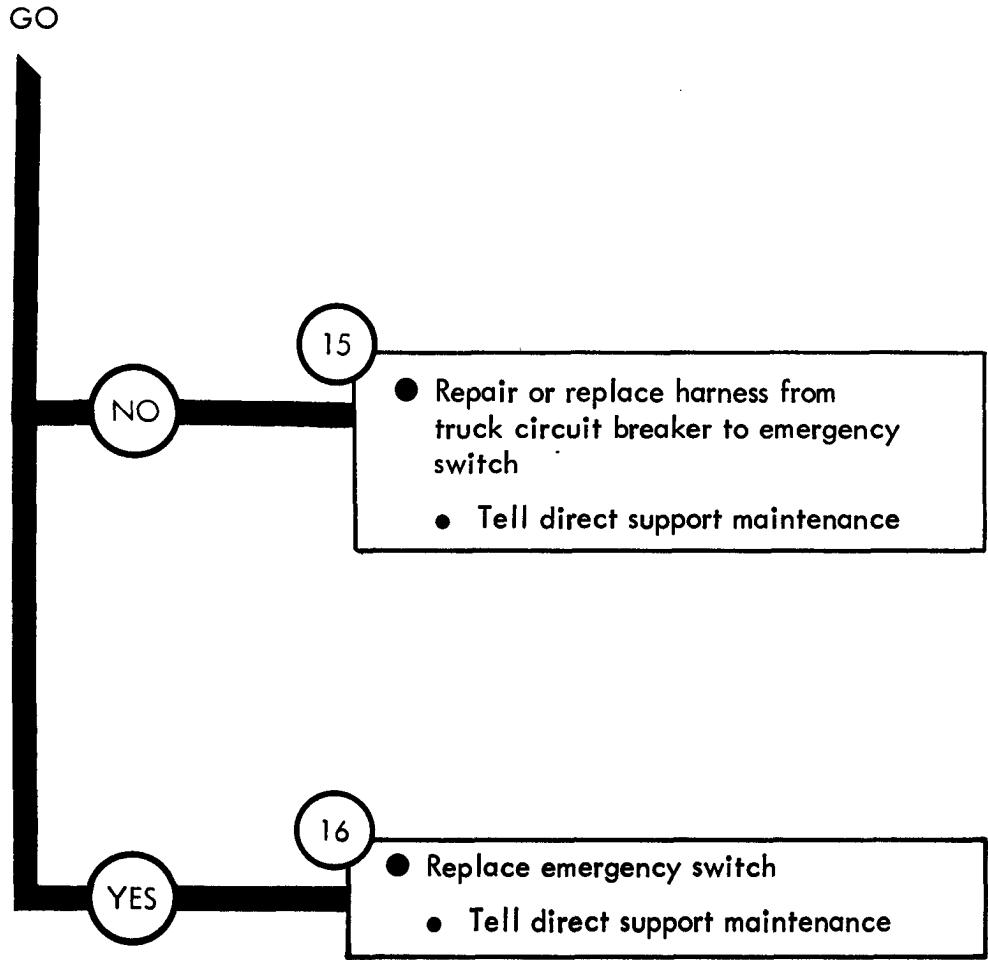

Figure 25-49 (Sheet 9 of 9)

Symptom

50

NEITHER CONTROL BOX WILL OPERATE THE HEATER FUEL PUMP

NOTE

When measuring voltage +24 volts DC means a range of +23 to +26 volts DC

1

- Park truck
- Refer to TM 9-2320-209-10

GO

Figure 25-50 (Sheet 1 of 11)

GO

2

- Check for +24 volts DC at heater fuel pump
 - Take off lead from both control boxes to heater fuel pump at the fuel pump
 - Set control boxes to ON
 - Set multimeter to measure +24 volts DC. Refer to test equipment procedures index
 - Put multimeter - lead on a good ground
 - Put multimeter + lead on lead contact. Read multimeter. Multimeter should measure +24 volts DC

Does multimeter measure +24 volts DC?

GO

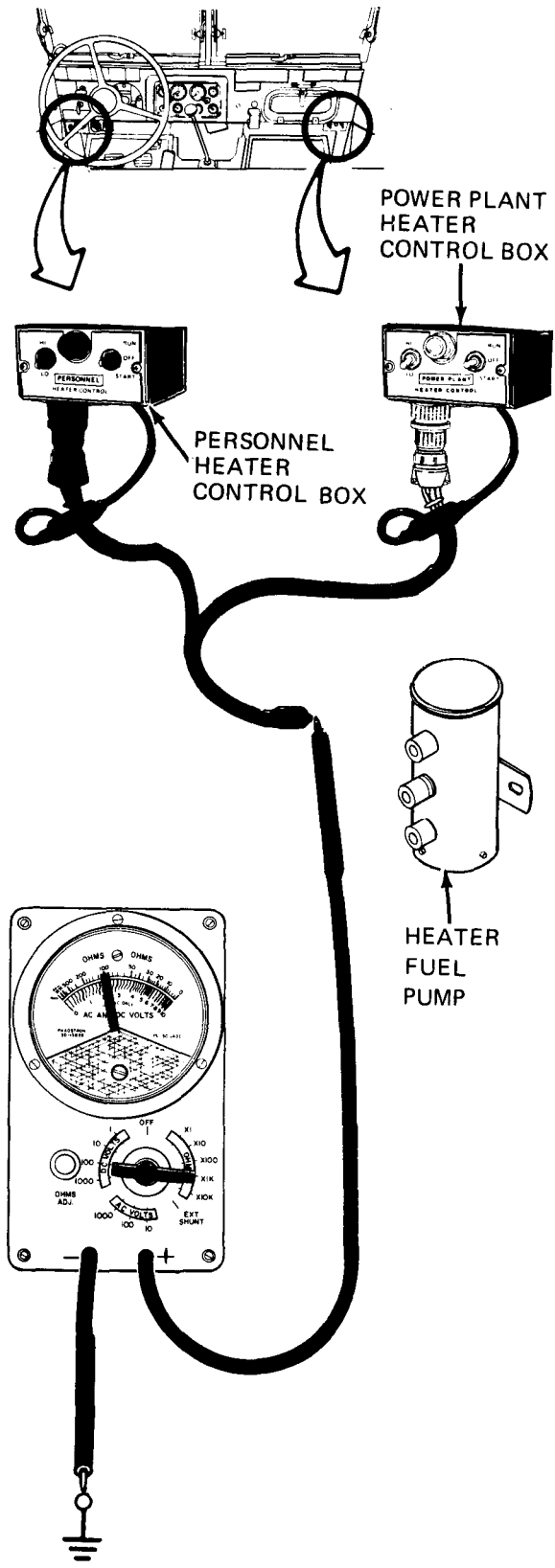

Figure 25-50 (Sheet 2 of 11)

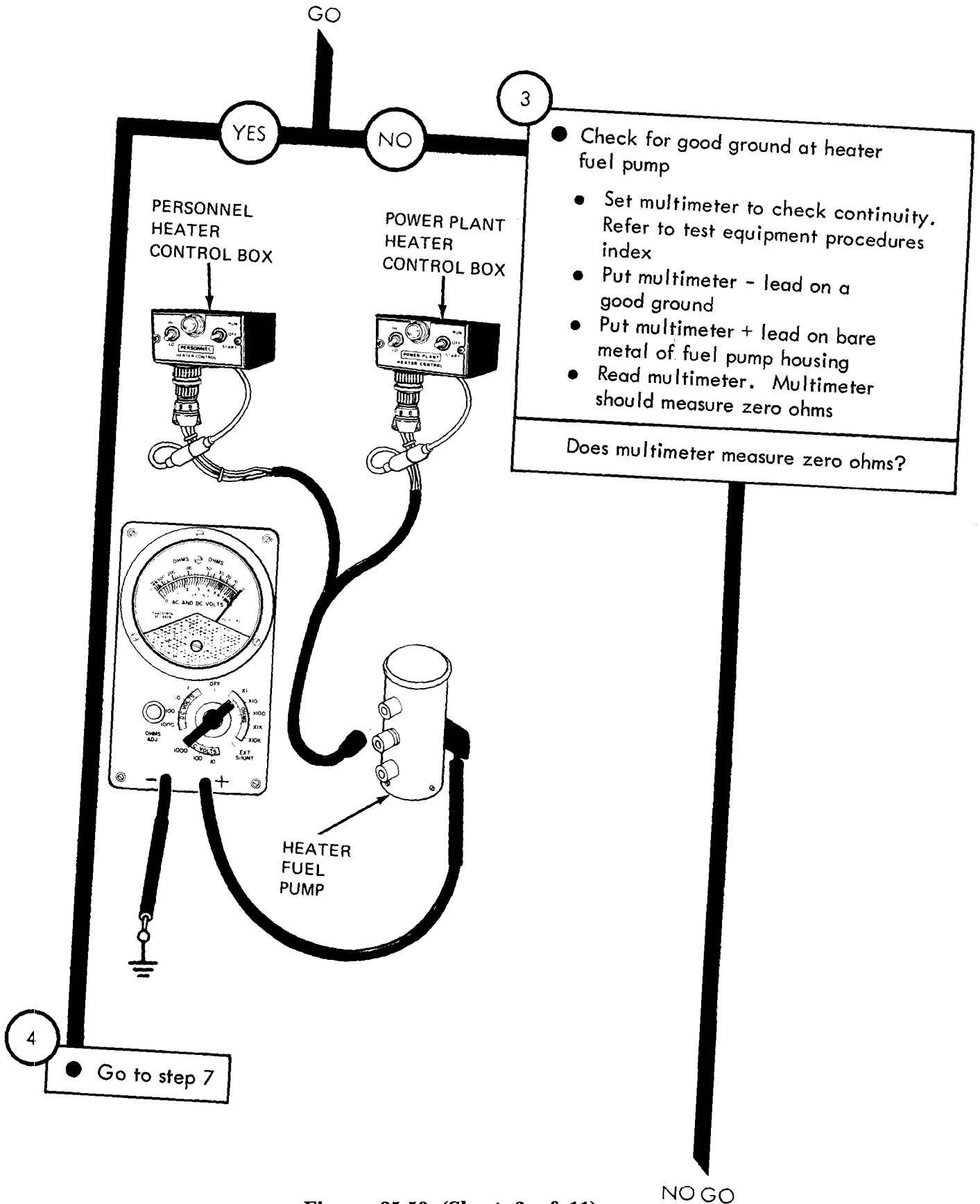

Figure 25-50 (Sheet 3 of 11)

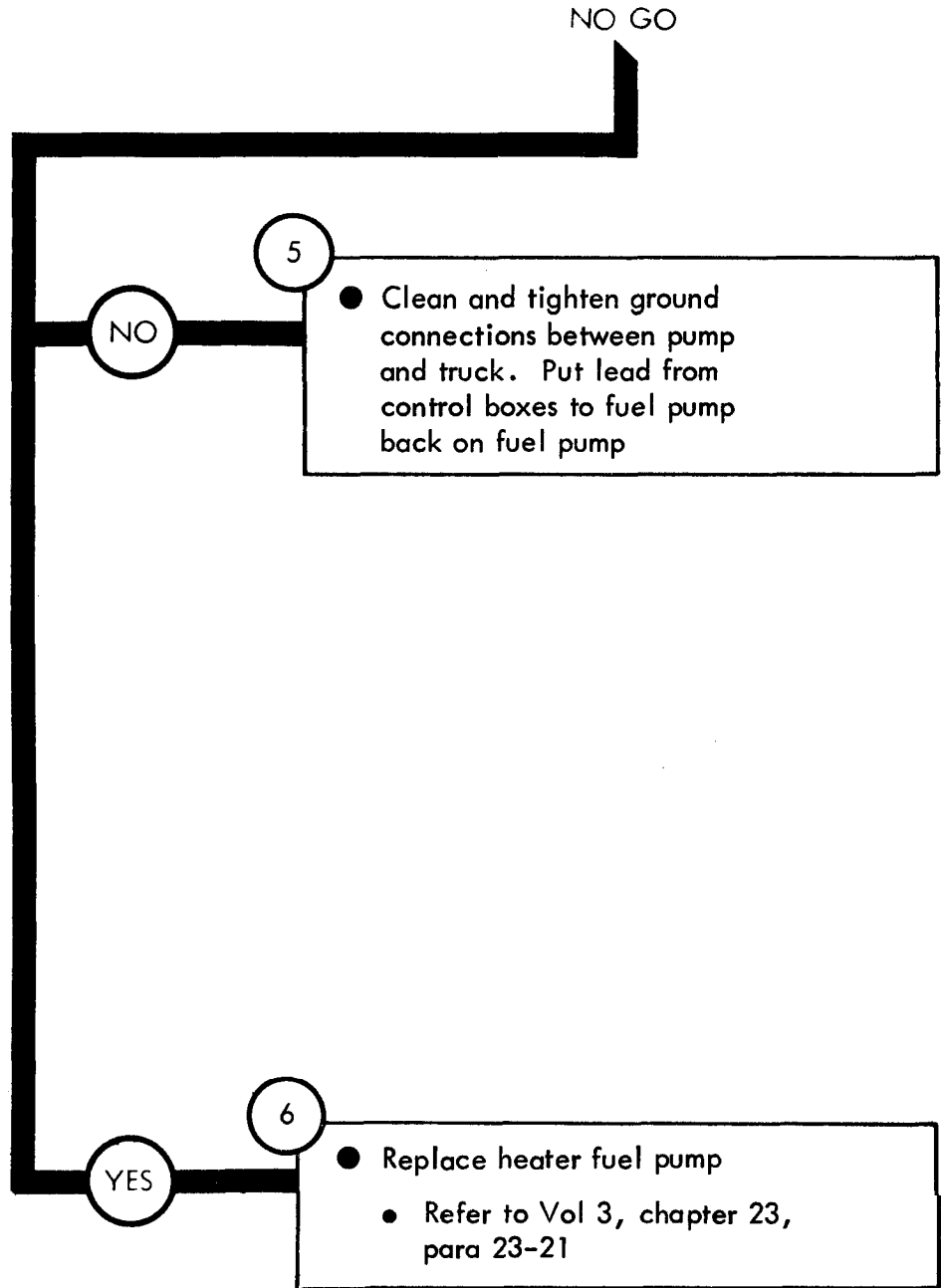

Figure 25-50 (Sheet 4 of 11)

TA 114590

From Step 4

7

- Check voltage through power plant heater control box
 - Put lead from control box to fuel pump back on fuel pump
 - Take off lead 400 from emergency switch to power plant heater control box at control box
 - Put multimeter - lead on a good ground
 - Put multimeter + lead on contact of lead 400 removed from control box
 - Read multimeter. Multimeter should measure +24 volts DC
- Does multimeter measure less than +24 volts DC?

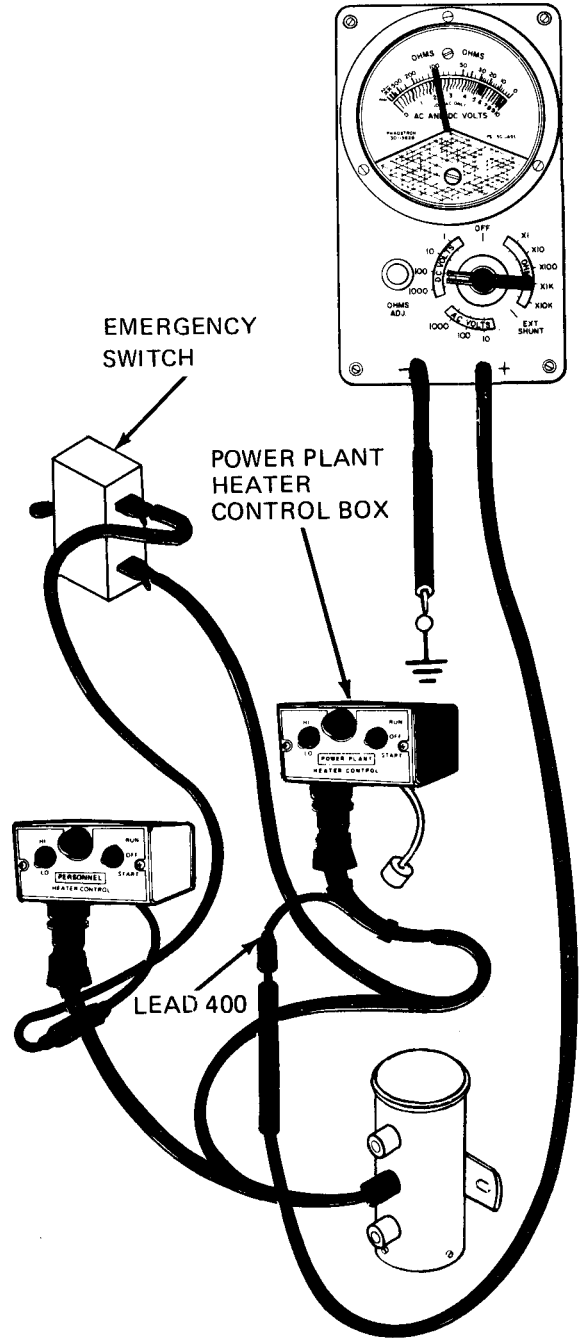

8

- Replace power plant heater control box
 - Tell direct support maintenance

YES

NO

GO

Figure 25-50 (Sheet 5 of 11)

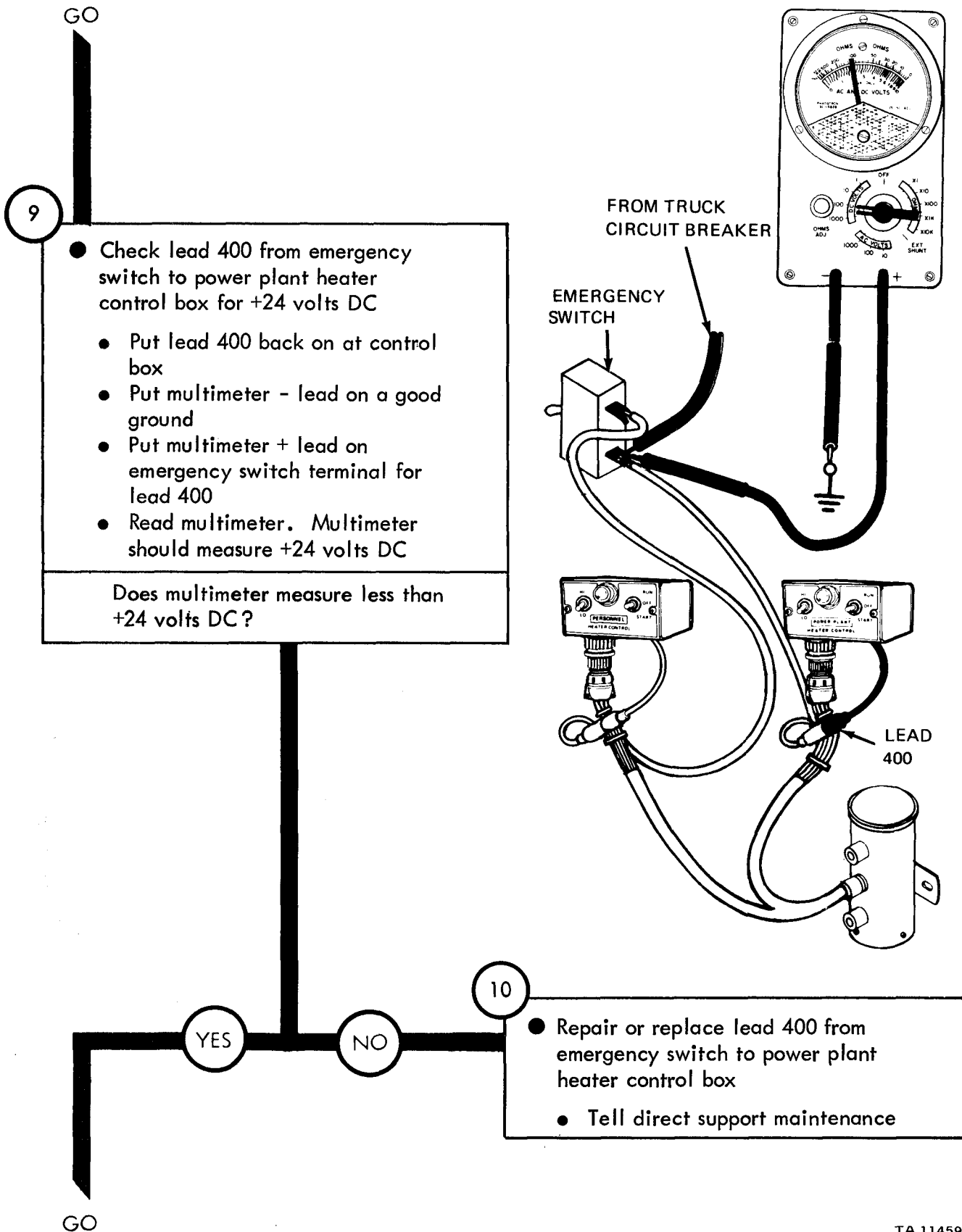
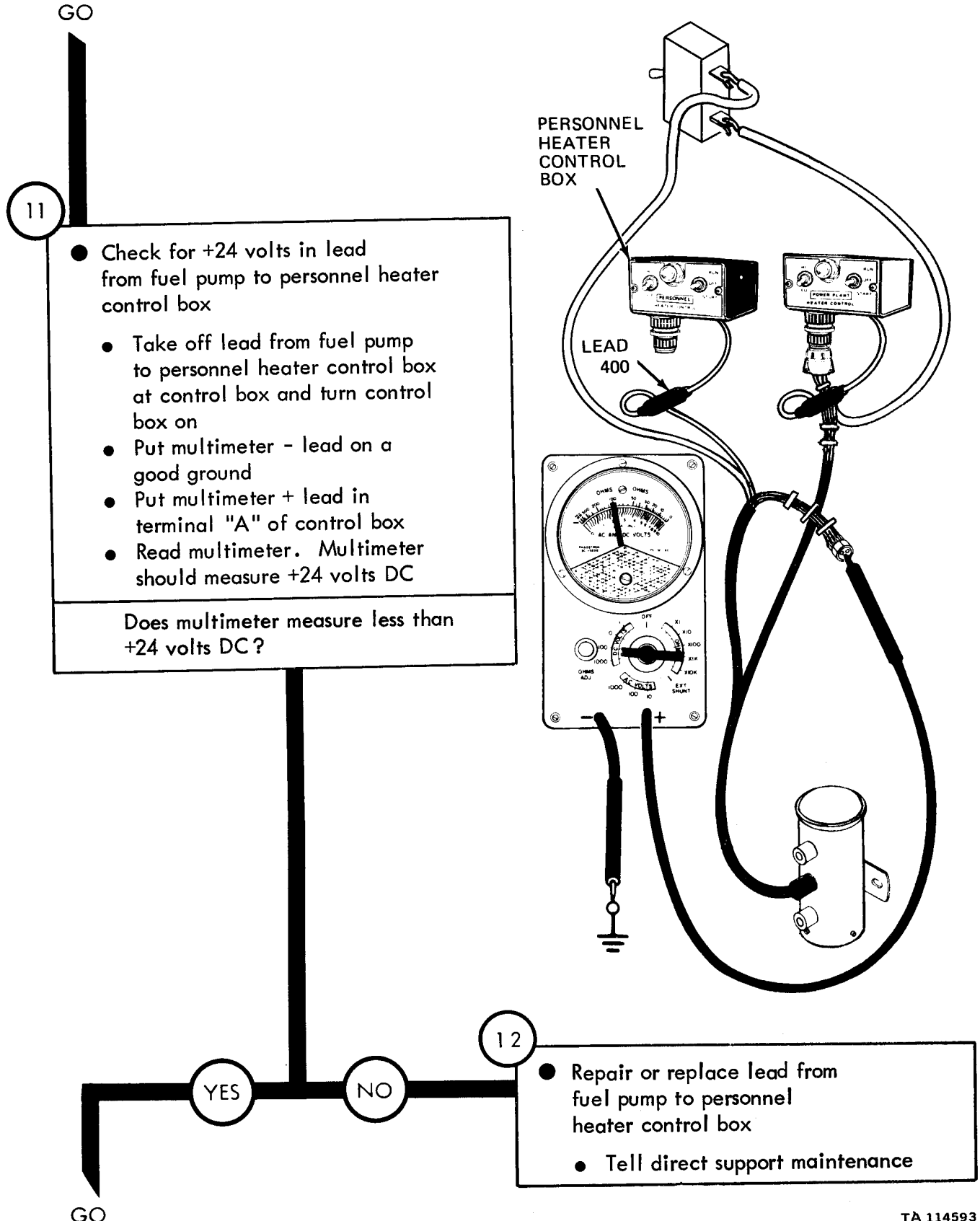

Figure 25-50 (Sheet 6 of 11)

TA 114592



11

- Check for +24 volts in lead from fuel pump to personnel heater control box
 - Take off lead from fuel pump to personnel heater control box at control box and turn control box on
 - Put multimeter - lead on a good ground
 - Put multimeter + lead in terminal "A" of control box
 - Read multimeter. Multimeter should measure +24 volts DC
- Does multimeter measure less than +24 volts DC?

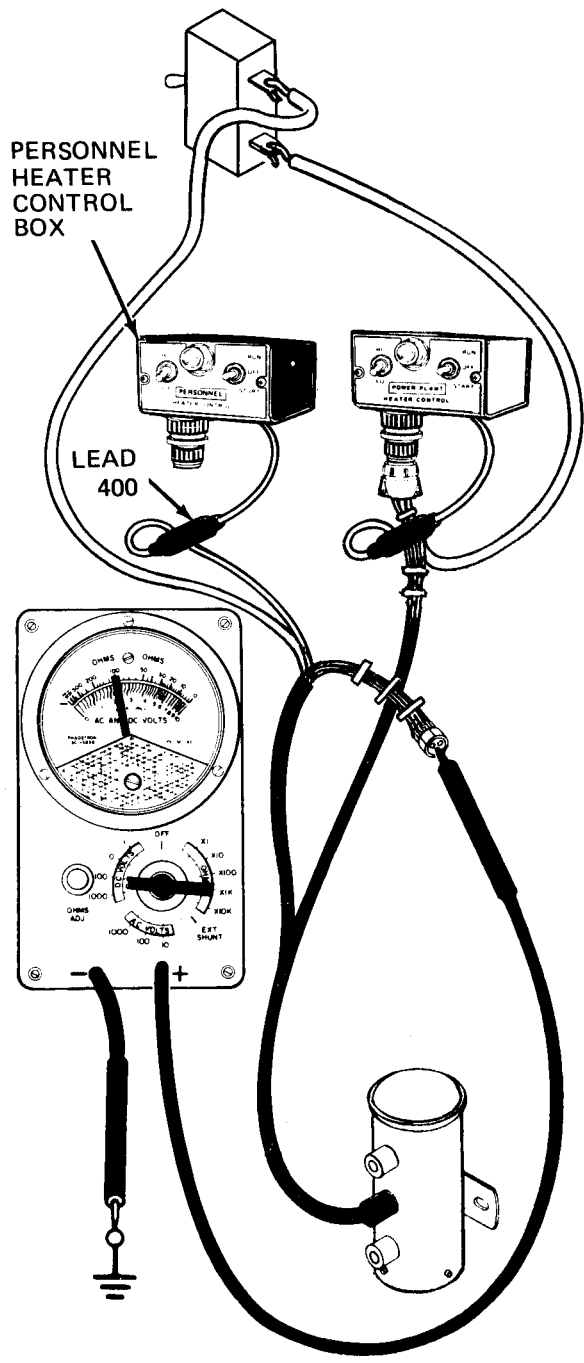

YES

NO

12

- Repair or replace lead from fuel pump to personnel heater control box
- Tell direct support maintenance

GO

Figure 25-50 (Sheet 7 of 11)

GO

13

- Check for +24 volts through personnel heater control box
 - Put lead from fuel pump to personnel heater control box back on at control box
 - Take off lead 400 from personnel heater control box
 - Put multimeter - lead on a good ground
 - Put multimeter + lead on terminal of lead 400
 - Read multimeter. Multimeter should measure +24 volts DC

Did multimeter measure less than +24 volts DC?

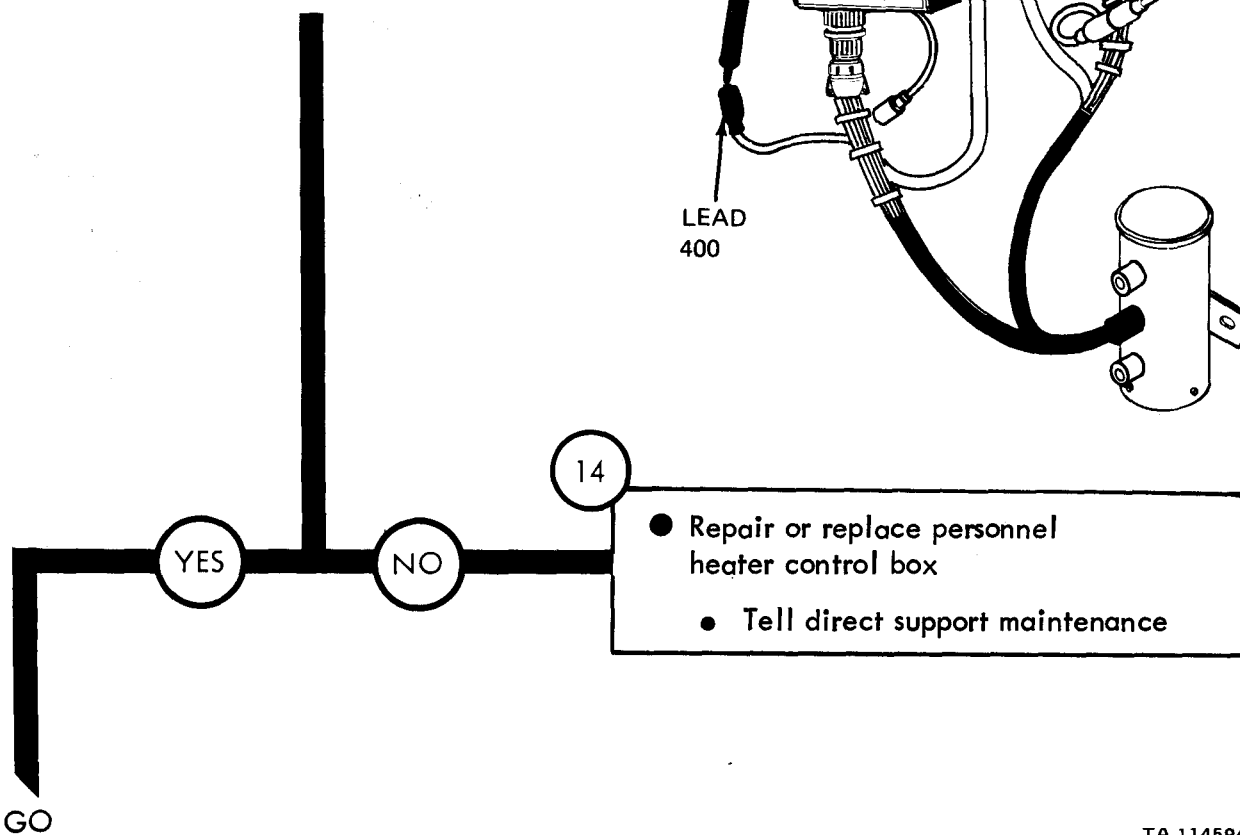
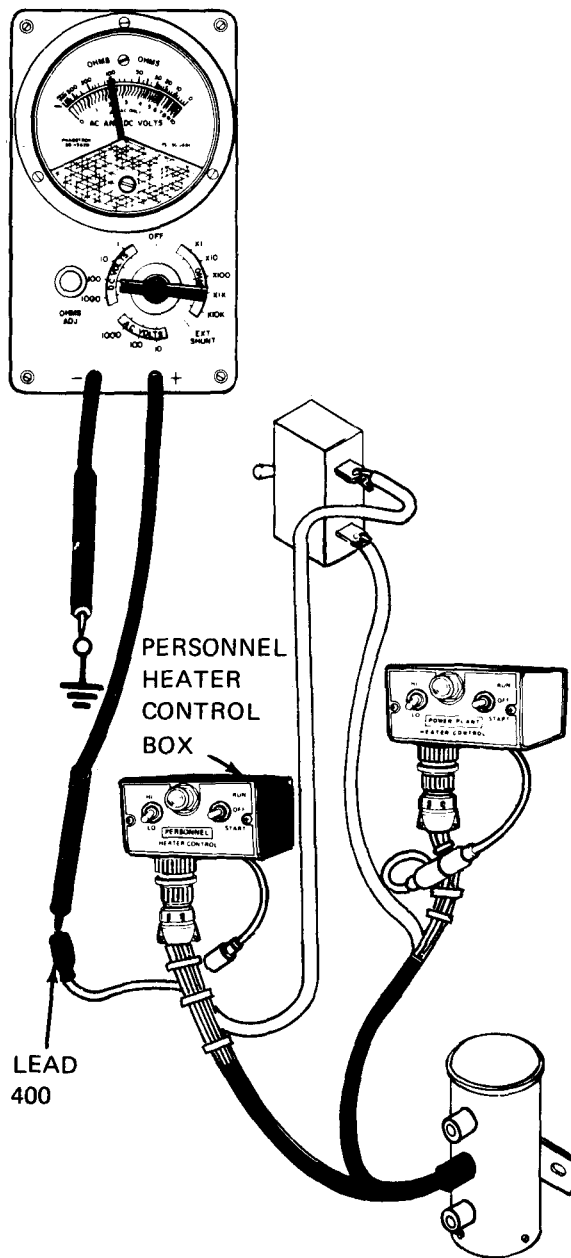

Figure 25-50 (Sheet 8 of 11)

GO

15

- Check lead 400 from personnel heater control box for +24 volts DC
- Put lead 400 back on control box
- Put multimeter - lead on a good ground
- Put multimeter + lead on lead 400 terminal of emergency switch
- Read multimeter. Multimeter should measure +24 volts DC

K Does multimeter measure less than

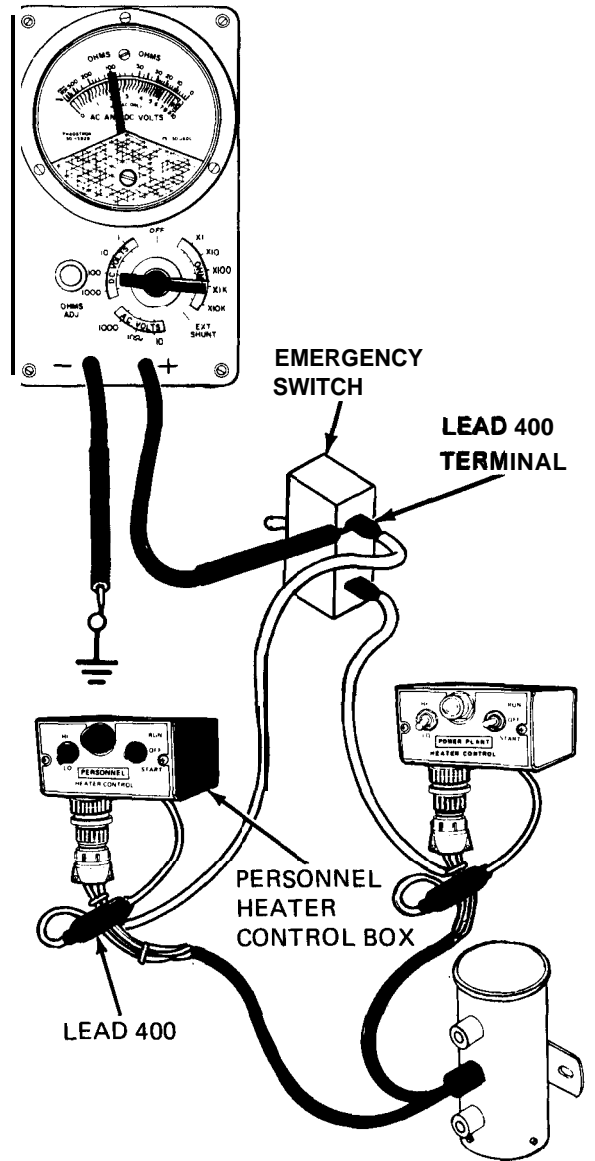

YES

NO

16

- Repair or replace lead 400 from emergency switch to personnel heater control box
- Tell direct support maintenance

GO

Figure 25-50 (Sheet 9 of 11)

GO

17

- Check voltage through heater control box
 - At emergency switch takeoff lead from truck circuit breaker
 - Put **multimeter** - lead on a good ground
 - Put **multimeter** + lead on contact of lead from truck circuit breaker
 - Read **multimeter**. **Multimeter** should measure +24 volts DC
- Does **multimeter** measure +24 volts DC?

GO

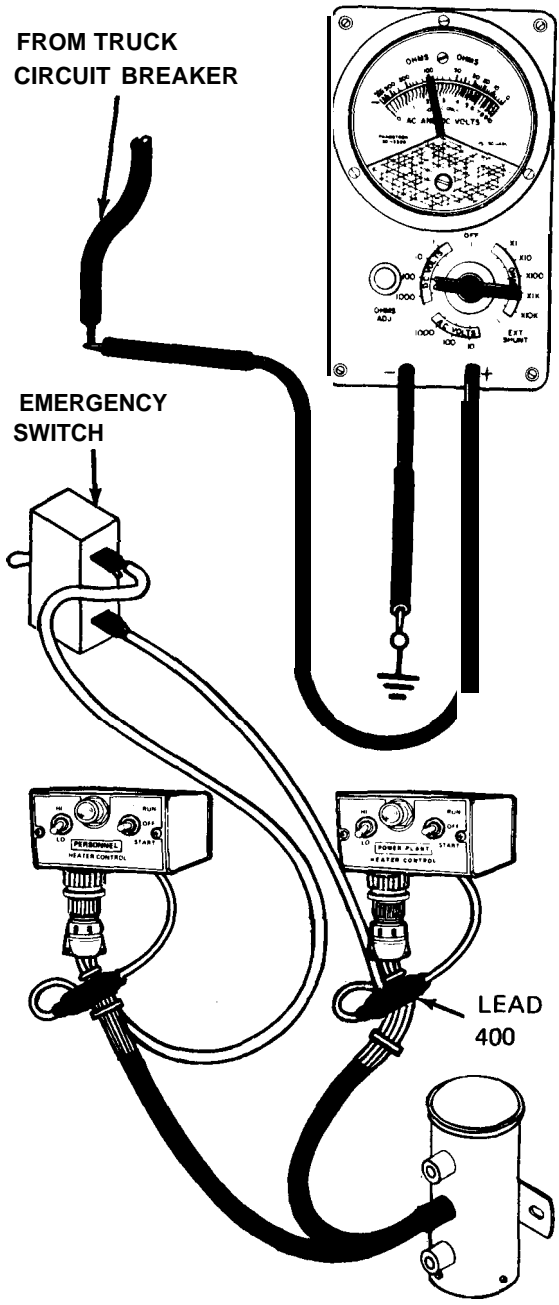

TA 114596

Figure 25-50 (Sheet 10 of 11)

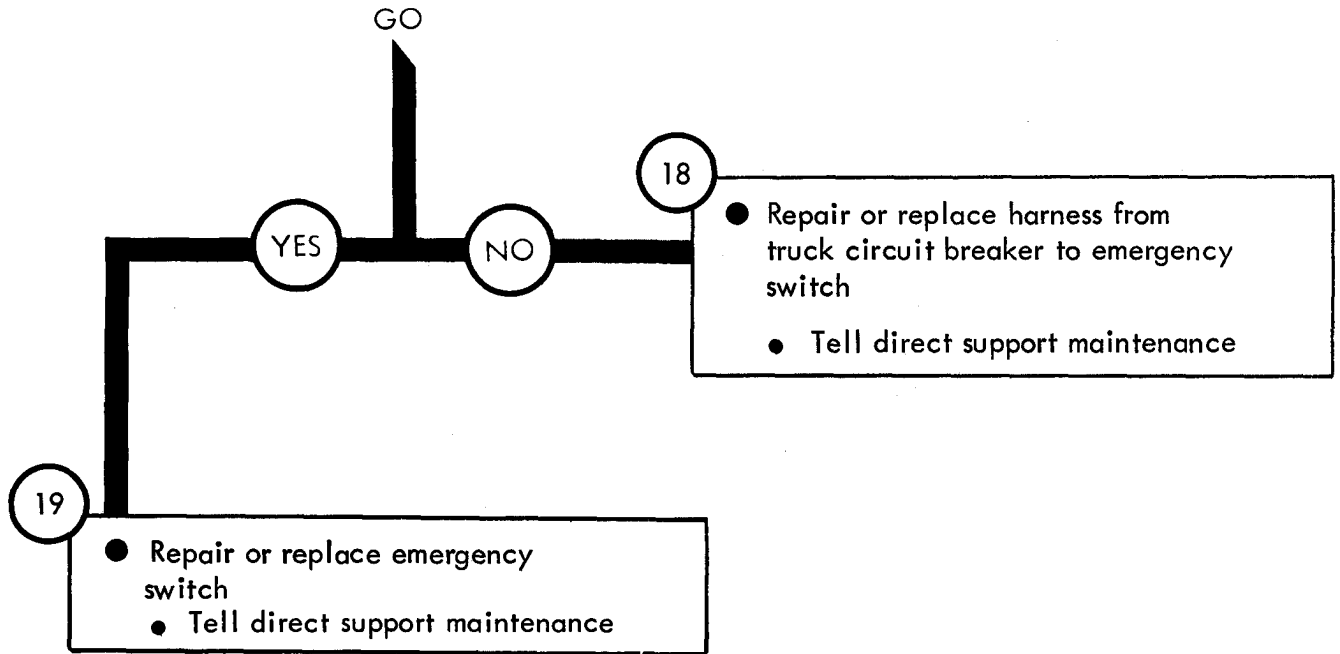

Figure 25-50 (Sheet 11 of 11)

By Order of the Secretaries of the Army and the Air Force:

E. C. MEYER
General, United States Army
Chief of Staff

Official:

J. C. PENNINGTON
Major General, United States Army
The Adjutant General

LEW ALLEN, JR., General, USAF
Chief of Staff

Official:

VAN L. CRAWFORD, JR., Colonel, USAF
Director of Administration

Distribution:

To be distributed in accordance with DA Form 12-38, Organizational Maintenance requirements for 2-1/2-Ton Truck Cargo, 2-1/2-Ton Truck Van, etc.

RECOMMENDED CHANGES TO EQUIPMENT TECHNICAL PUBLICATIONS



THEN... JOT DOWN THE DOPE ABOUT IT ON THIS FORM, CAREFULLY TEAR IT OUT, FOLD IT AND DROP IT IN THE MAIL!

SOMETHING WRONG WITH THIS PUBLICATION?

FROM (PRINT YOUR UNIT'S COMPLETE ADDRESS)
 CDR, 1st Bn, 65th ADA
 Attn: SP4 Jane Idone
 Key West, FL 33040

DATE SENT
 Date sent in

PUBLICATION NUMBER: TM 9-2320-209-20-2-1
 PUBLICATION DATE: 27 May 1981
 PUBLICATION TITLE: ORGANIZATIONAL TROUBLESHOOTING MANUAL

BE EXACT... PIN-POINT WHERE IT IS				IN THIS SPACE TELL WHAT IS WRONG AND WHAT SHOULD BE DONE ABOUT IT:
PAGE NO	PARA-GRAPH	FIGURE NO	TABLE NO	
5-14		5-13		WHEEL SYSTEM chart should be changed to add a fourth breakdown on tires. Add TIRE MOUNTING to chart.
6-2			6-1	Subsystem LUBRICATION, symptom 2, summary refers to figure 9-10. Should refer to figure 9-1.
25-131		25-14 (Sheet 3 of 24)		Box 6, second sentence reads "Set light switch main lever." Should read "Set light switch main lever to OFF."

SAMPLE

PRINTED NAME GRADE OR TITLE AND TELEPHONE NUMBER
 SP4 Jane Idone Avovon 222-2224

SIGN HERE
Jane Idone

FILL IN YOUR UNIT'S ADDRESS



FOLD

DEPARTMENT OF THE ARMY

OFFICIAL BUSINESS
PENALTY FOR PRIVATE USE \$.

SAMPLE

POSTAGE AND FEES PAID
DEPARTMENT OF THE ARMY
DOD 314



TEAR ALONG PERFORATED LINE

Commander
U.S. Army Tank-Automotive Command
ATTN: DRSTA-MB
Warren, MI 48090

RECOMMENDED CHANGES TO EQUIPMENT TECHNICAL PUBLICATIONS



THEN... JOT DOWN THE DOPE ABOUT IT ON THIS FORM. CAREFULLY TEAR IT OUT. FOLD IT AND DROP IT IN THE MAIL!

SOMETHING WRONG WITH THIS PUBLICATION?

FROM (PRINT YOUR UNIT'S COMPLETE ADDRESS)

DATE SENT

PUBLICATION NUMBER

TM 9-2320-209-20-2-1

PUBLICATION DATE

27 May 1981

PUBLICATION TITLE

ORGANIZATIONAL TROUBLESHOOTING MANUAL

BE EXACT PIN-POINT WHERE IT IS

PAGE NO

PARA-GRAPH

FIGURE NO

TABLE NO

IN THIS SPACE TELL WHAT IS WRONG AND WHAT SHOULD BE DONE ABOUT IT:

PRINTED NAME GRADE OR TITLE AND TELEPHONE NUMBER

SIGN HERE

FILL IN YOUR
UNIT'S ADDRESS

FOLD BACK

TEAR ALONG PERFORATED LINE

DEPARTMENT OF THE ARMY

OFFICIAL BUSINESS
PENALTY FOR PRIVATE USE \$300

POSTAGE AND FEES PAID
DEPARTMENT OF THE ARMY
DOD 314



Commander
U.S. Army Tank-Automotive Command
ATTN: DRSTA-MB
Warren, MI 48090

RECOMMENDED CHANGES TO EQUIPMENT TECHNICAL PUBLICATIONS



THEN... JOT DOWN THE DOPE ABOUT IT ON THIS FORM. CAREFULLY TEAR IT OUT. FOLD IT AND DROP IT IN THE MAIL.

SOMETHING WRONG WITH THIS PUBLICATION?

FROM (PRINT YOUR UNIT'S COMPLETE ADDRESS)

DATE SENT

PUBLICATION NUMBER

TM 2320 -209-20-2-1

PUBLICATION DATE

27 May 1981

PUBLICATION TITLE

ORGANIZATIONAL TROUBLESHOOTING MANUAL

BE EXA PIN-POINT WHERE IT IS

PAGE NO	PARA-GRAPH	FIGURE NO	TABLE NO
---------	------------	-----------	----------

IN THIS SPACE TELL WHAT IS WRONG AND WHAT SHOULD BE DONE ABOUT IT:

PRINTED NAME GRADE OR TITLE AND TELEPHONE NUMBER

SIGN HERE

FILL IN YOUR
UNIT'S ADDRESS

FOLD BACK

TEAR ALONG PERFORATED LINE

DEPARTMENT OF THE ARMY

POSTAGE AND FEES PAID
DEPARTMENT OF THE ARMY
DOD 314



OFFICIAL BUSINESS
PENALTY FOR PRIVATE USE \$300

Commander
U.S. Army Tank-Automotive Command
ATTN: DRSTA-MB
Warren, MI 48090

SOMETHING WRONG WITH THIS PUBLICATION?



THEN, JOT DOWN THE
DOPE ABOUT IT ON THIS
FORM. CAREFULLY TEAR IT
OUT, FOLD IT AND DROP IT
IN THE MAIL.

FROM (PRINT YOUR UNIT'S COMPLETE ADDRESS)

DATE SENT

PUBLICATION NUMBER

TM 9-2320 -209-20-2-1

PUBLICATION DATE

27 May 1981

PUBLICATION TITLE

ORGANIZATIONAL TROUBLESHOOTING
MANUAL

BE EXACT PIN-POINT WHERE IT IS

PAGE
NO

PARA-
GRAPH

FIGURE
NO

TABLE
NO

IN THIS SPACE TELL WHAT IS WRONG
AND WHAT SHOULD BE DONE ABOUT IT:

PRINTED NAME GRADE OR TITLE AND TELEPHONE NUMBER

SIGN HERE

FILL IN YOUR
UNIT'S ADDRESS

FOLD BACK

TEAR ALONG PERFORATED LINE

DEPARTMENT OF THE ARMY

POSTAGE AND **FEES** PAID
DEPARTMENT **OF** THE ARMY
DOD 314



OFFICIAL BUSINESS
PENALTY FOR PRIVATE USE \$300

Commander
U.S. Army Tank-Automotive Command
AI_ TN: DRSTA-MB
Warren, MI 48090

THE METRIC SYSTEM AND EQUIVALENTS

LINEAR MEASURE

1 Centimeter = 10 Millimeters = 0.01 Meters = 0.3937 Inches
 1 Meter = 100 Centimeters = 1000 Millimeters = 39.37 Inches
 1 Kilometer = 1000 Meters = 0.621 Miles

SQUARE MEASURE

1 Sq Centimeter = 100 Sq Millimeters = 0.155 Sq Inches
 1 Sq Meter = 10,000 Sq Centimeters = 10.76 Sq Feet
 1 Sq Kilometer = 1,000,000 Sq Meters = 0.386 Sq Miles

WEIGHTS

1 Gram = 0.001 Kilograms = 1000 Milligrams = 0.035 Ounces
 1 Kilogram = 1000 Grams = 2.2 Lb
 1 Metric Ton = 1000 Kilograms = 1 Megagram = 1.1 Short Tons

CUBIC MEASURE

1 Cu Centimeter = 1000 c. Millimeters = 0.06 Cu Inches
 1 c. Meter = 1,000,000 Cu Centimeters = 35.31 C. Feet

LIQUID MEASURE

1 Milliliter = 0.001 Liters = 0.0338 Fluid Ounces
 1 Liter = 1000 Milliliters = 33.82 Fluid Ounces

TEMPERATURE

$5/9 (^{\circ}\text{F} - 32) = ^{\circ}\text{C}$
 212° Fahrenheit is equivalent to 100° Celsius
 90° Fahrenheit is equivalent to 32.2° Celsius
 $32^{\circ}\text{ Fahrenheit is equivalent to } 0^{\circ}\text{ Celsius}$
 $9/5 \text{ } ^{\circ}\text{C} + 32 = \text{ } ^{\circ}\text{F}$

APPROXIMATE CONVERSION FACTORS

<u>TO CHANGE</u>	<u>TO</u>	<u>MUL. PLY BY</u>
Inches	Centimeters	2.540
Feet	Meters	0.305
Yards	Meters	0.914
Miles	Kilometers	1.609
Square Inches	Square Centimeters	6.451
Square Feet	Square Meters	0.093
Square Yards	Square Meters	0.836
Square Miles	Square Kilometers	2.590
Acres	Square Hectometers	0.405
Cubic Feet	Cubic Meters	: 0.028
Cubic Yards	Cubic Meters	0.765
Fluid Ounces	Milliliters	29.573
Pints	Liters	: 0.473
Quarts	Liters	: 0.946
Gallons	Liters	3.785
Ounces	Grams	: 28.349
Pounds	Kilograms	0.454
Short Tons	Metric Tons	0.907
Pound-Feet	Newton-Meters	1.356
Pounds per Square Inch	Kilopascals	6.895
Miles per Gallon	Kilometers per Liter	0.425
Miles per Hour	Kilometers per Hour	1.609

<u>TO CHANGE</u>	<u>TO</u>	<u>MULTIPLY BY</u>
Centimeters	Inches	0.394
Meters	Feet	3.280
Meters	Yards	1.094
Kilometers	Miles	0.621
Square Centimeters	Square Inches	0.155
Square Meters	Square Feet	10.764
Square Meters	Square Yards	1.196
Square Kilometers	Square Miles	0.386
Square Hectometers	Acres	2.471
Cubic Meters	Cubic Feet	35.315
Cubic Meters	Cubic Yards	1.308
Milliliters	Fluid Ounces	0.034
Liters	Pints	2.113
Liters	Quarts	1.057
Liters	Gallons	0.264
Grams	Ounces	0.035
Kilograms	Pounds	2.205
Metric Tons	Short Tons	1.102
Newton-Meters	Pound-Feet	0.738
Kilopascals	Pounds per Square Inch	0.145
Kilometers per Liter	Miles per Gallon	2.354
Kilometers per Hour	Miles per Hour	0.621

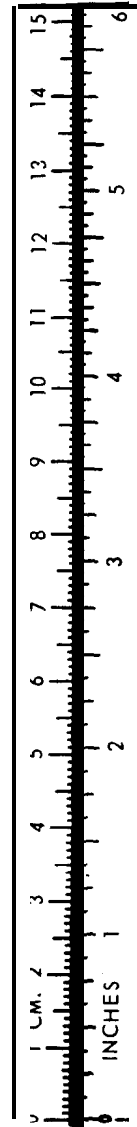

TAO8999

